

MEMS Based Fuzing/Safety and Arming Systems

Paul J. Smith

Weapons Department
Indian Head Division
Naval Surface Warfare Center
Indian Head, Maryland 20640
USA

MicroElectroMechanical Systems or MEMS is a fabrication technology for creating mechanical devices on micron scale (1×10^{-6} meters). But MEMS is more than miniaturization. By combining, photolithography, deposition, patterning and etching a fabrication technology has resulted for the production full-assembled, integrated electromechanical systems on a scale once reserved for electronic integrated circuits (IC). As the first M of MEMS implies, individual features are on the micron scale that is 10^{-6} meters but the resulting systems can be several millimeters in size.

Since MEMS has its roots in the IC industry, let's briefly examine the IC history. In the last half century the cost of logic 'NAND' gate has fallen by five orders of magnitude. This is a result of changes in manufacturing technology from hand-assembled vacuum tube gates to mass produced Very Large Scale Integration (VLSI) devices. In the last quarter century, the number of transistor/inch has doubled every 2.5 years. Recently, Intel has announced that the number of transistors on a chip will exceed 1 billion by the year 2010. While size and cost has decreased the performance has increased as indicated by the initial microprocessor clock rate of 4.7 Mega Hertz in 1980's to in excess of 2.0 Gig Hertz for today's units. These changes are a result of modern photolithography/batch fabrication techniques. Where as IC industry deposited/doped P and N materials, MEMS deposits and etches to creates mechanical structures.

MEMS and modern IC industry are based on a process of deposition-patterning- removal techniques. The process centers around deposition of material on a silicon wafer, patterning via a mask, and removal of un-patterned material. The basic process is repeated dozen of times with many variations. For example, a variety of material can be deposited (polycrystalline silicon, nitride, PMMA, photo resists, metals, etc), via photolithography using a mask and energy source (light, x-rays) either the exposed or the unexposed material can be altered and removed (chemically, ion etched, laser ablated) or silicon wafer can be replaced with silicon carbide wafer for higher temperature performance. Fabrication (Fig. 1) can be divided into three basic methods: Bulk Micro Machining, Surface Micro Machining, and LIGA. In bulk micro machining, part of the silicon wafer is removed by chemical etching or reactive ion etching. This method allows fabrication of diaphragms, cavities and thick structures (400 μm). In Surface Micro machining, material are deposited on top of the silicon wafer. Structures may be anchored to the wafer, free floating or partially tethered to the silicon wafer. Structures are thin ($<15 \mu\text{m}$) and are generally polycrystalline silicon, nitride, and metals. The third fabrication method (LIGA) begins with the deposition of layer of PMMA (plastic) on the silicon wafer. The PMMA serves as a mold for metal and plastic parts. It offers the advantage on tall structures as compared to surface micro machining. Thus, the design engineers have a variety of materials and dimensions available for designs.

Paper presented at the RTO AVT Lecture Series on "MEMS Aerospace Applications", held in Montreal, Canada, 3-4 October 2002; Ankara, Turkey, 24-25 February 2003; Brussels, Belgium, 27-28 February 2003; Monterey, CA, USA, 3-4 March 2003, and published in RTO-EN-AVT-105.

Report Documentation Page

*Form Approved
OMB No. 0704-0188*

Public reporting burden for the collection of information is estimated to average 1 hour per response, including the time for reviewing instructions, searching existing data sources, gathering and maintaining the data needed, and completing and reviewing the collection of information. Send comments regarding this burden estimate or any other aspect of this collection of information, including suggestions for reducing this burden, to Washington Headquarters Services, Directorate for Information Operations and Reports, 1215 Jefferson Davis Highway, Suite 1204, Arlington VA 22202-4302. Respondents should be aware that notwithstanding any other provision of law, no person shall be subject to a penalty for failing to comply with a collection of information if it does not display a currently valid OMB control number.

1. REPORT DATE 00 FEB 2004	2. REPORT TYPE N/A	3. DATES COVERED -			
4. TITLE AND SUBTITLE MEMS Based Fuzing/Safety and Arming Systems		5a. CONTRACT NUMBER			
		5b. GRANT NUMBER			
		5c. PROGRAM ELEMENT NUMBER			
6. AUTHOR(S)		5d. PROJECT NUMBER			
		5e. TASK NUMBER			
		5f. WORK UNIT NUMBER			
7. PERFORMING ORGANIZATION NAME(S) AND ADDRESS(ES) Weapons Department Indian Head Division Naval Surface Warfare Center Indian Head, Maryland 20640 USA		8. PERFORMING ORGANIZATION REPORT NUMBER			
9. SPONSORING/MONITORING AGENCY NAME(S) AND ADDRESS(ES)		10. SPONSOR/MONITOR'S ACRONYM(S)			
		11. SPONSOR/MONITOR'S REPORT NUMBER(S)			
12. DISTRIBUTION/AVAILABILITY STATEMENT Approved for public release, distribution unlimited					
13. SUPPLEMENTARY NOTES See also ADM001658., The original document contains color images.					
14. ABSTRACT					
15. SUBJECT TERMS					
16. SECURITY CLASSIFICATION OF:			17. LIMITATION OF ABSTRACT SAR	18. NUMBER OF PAGES 8	19a. NAME OF RESPONSIBLE PERSON
a. REPORT unclassified	b. ABSTRACT unclassified	c. THIS PAGE unclassified			

Fabrication Methods

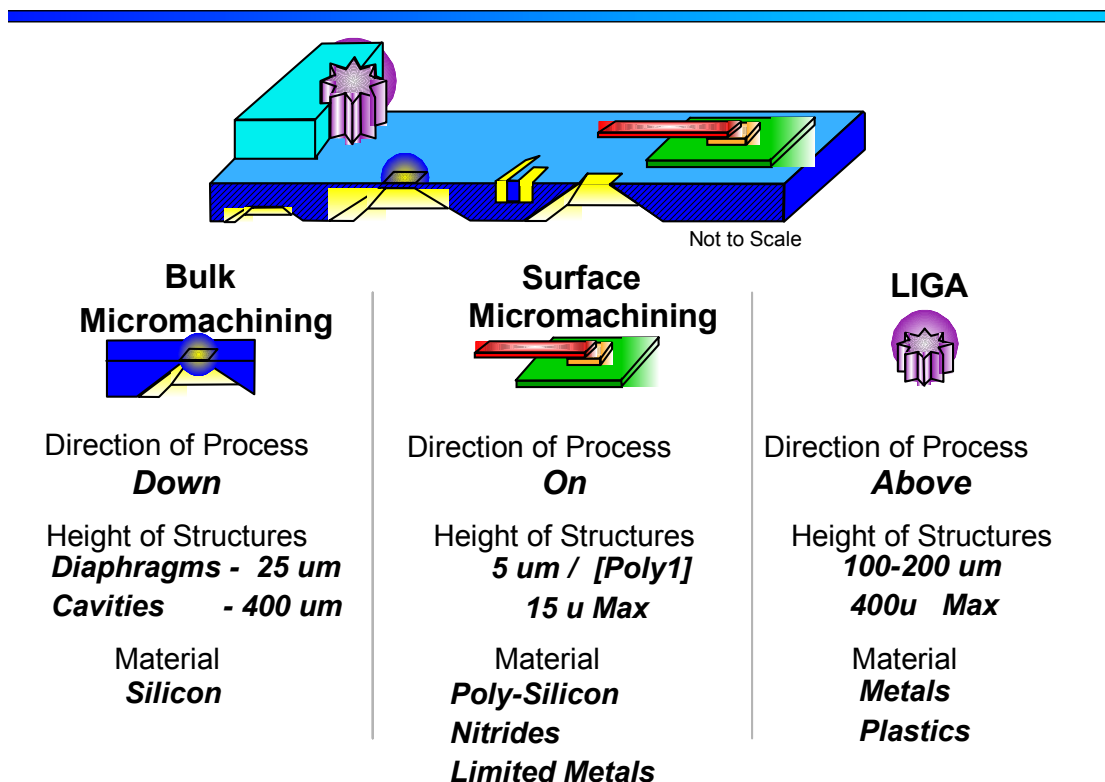
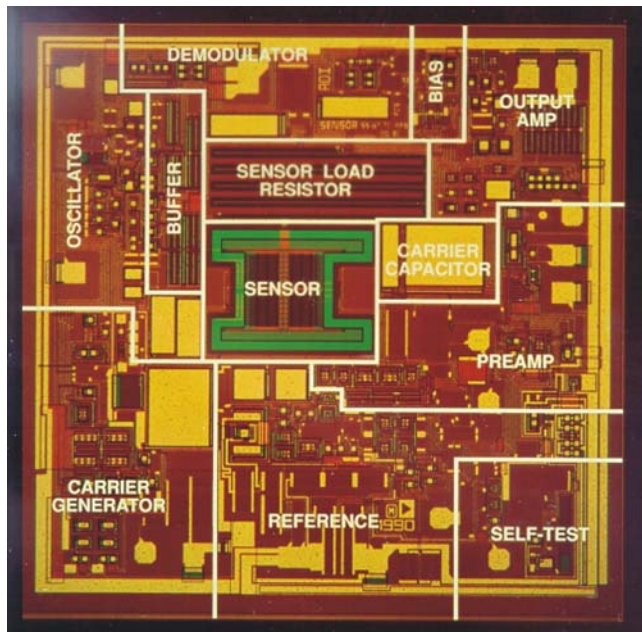

Figure 1.

The “S” of MEMS stands for System. A MEMS system has the ability to sense, process the data, and act. The last part developed was the actuator or device capable of producing movement. In 1991, Analog Device Inc (ADI) marketed the first full MEMS systems with the introduction of the air bag accelerometer for automobiles (Fig. 2). It has a proof mass to sense acceleration, capacitive fingers to sense its movement. The capacitor is an element in a tuned circuit oscillator. Frequency shifts are detected and produce a voltage proportional to the frequency shift, which is used to control a second set of inter-leaved fingers to apply a restoring force to the proof mass to return it to a neutral position. The restoring voltage is directly related to the acceleration (amplitude and frequency).

MEMS Accelerometer

Sense -- Process -- Control



Bare Die (TO5 Removed)

Force Balanced Accelerometer

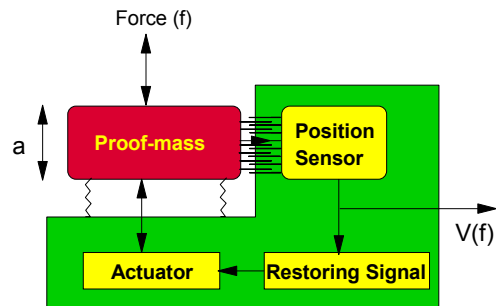

Analog Devices Inc

Figure 2.

MEMS is an ENABLING technology. It enables you to build systems on the micron scale. While individual features are on the micron scale the entire system can be several millimeters in dimension. It enables you to integrate mechanical and electrical systems. It enables batch fabrication of fully assembled systems. It enables systems that sense, process and control the environment. It is not a question of who will use MEMS but who uses MEMS. MEMS devices are currently used in automobile airbags, color inkjet printers, fuel injectors and automobile skid control system. MEMS will not only affect how things are made but what things are made. The technology will ultimately result in new medical devices for improved living and devices that improve automobile safety (air bags, skid control, etc.). MEMS also have the potential for improved safety devices containing energetic materials. In the first of two papers, I will discuss how energetic material are being integrated into a MEMS based Safety and Arming (S&A) system to create the next generation S&As.

A MEMS S&A has many advantages. First is the retention of classical mechanical lock for proven performance. MEMS offer a high level of integration between sensors and microprocessors. Improved environmental MEMS sensors (flow) means less reliance on pseudo environments (propeller turning counters). Due to reduce size and cost more sophisticated S&A can be applied to a larger variety of devices. As an emerging technology MEMS is an attractive choice to replace a declining S&A industrial base (bellows, miniature gear, etc.).

SAFETY & ARMING (S&A) SYSTEM

There are five basic requirements for an S&A system. First it must sense two independent post-launch environments to determine weapon launch. Secondly it must compute when safe separation between the weapon and launch platform has been achieved. It must “arm” the warhead when the first two requirements are met. It must provide a means to detonate the warhead at an appropriate time (fuzing). Finally it should provide a visual indication that the device is armed.

One of the engineering challenges of MEMS is using micro mechanisms to control macro events. How to scale up? We are using explosives to scale up. By using small amount of explosive (detonator) to ignite a larger quantity of explosive (booster) that in turn ignites a third charge (bulk charge) we can transition from the micron scale to the macro scale. A modified exploding foil initiation (EFI) (slapper) system has been designed. An EFI begins with a copper strip with a reduced cross section. Under the reduced cross section is an insulator over a barrel. Located at the end of the barrel is a secondary explosive. A large current is passed down the copper strip. At the reduced cross section the current density increase causing heat. The heat converts the copper to plasma. The plasma shears a pellet/flyer out of the insulator and launches down the barrel and into the explosive located at the other end. The flyer strikes the explosive with enough kinetic energy ($1/2 mv^2$) to create an explosion. Scientists and engineers at our facility have developed methods to mechanically open and close the barrel. Now that there is a mechanically moving structure it can be locked in a safe or armed position.

In our first generation S&A, three environmental sensors (a ‘g’ switch, a water pressure (hydrostat), a water flow sensor) were used (Figs. 3 & 4). The first sensor was a passive proof mass accelerometer that sensed launch acceleration and withdrew the locking pin from the slider/barrel. The hydrostat is a pressure sensor that directly moves a lever. A thin diaphragm was made in the silicon wafer by the bulk micro machining process. Using LIGA process a torsion beam was fabricated over the diaphragm. The movable end of the beam rested in a notch in the spring-loaded slider that formed the barrel of the EFI. When the underside of the silicon wafer was subjected to water pressure, the diaphragm would deflect upward pushing the beam upward and releasing the second lock. The third lock was a repackaged commercial differential pressure sensor. The two inputs were ported to the torpedo surface when a custom “Pitot tube” configuration was formed. Water flowing over the torpedo surface created a static and dynamic pressure where the difference was related to the speed via the shear profile function. Output of the sensor was connected to a thermal bent beam actuator. When heated by electric current the beam elongates, bends and releases the final lock. The devices and the spring-loaded barrel were fabricated on a single silicon chip. The chip when combined with high voltage initiation system, microprocessor, discrete logic and secondary explosive pellet formed the Safety and Arming system.

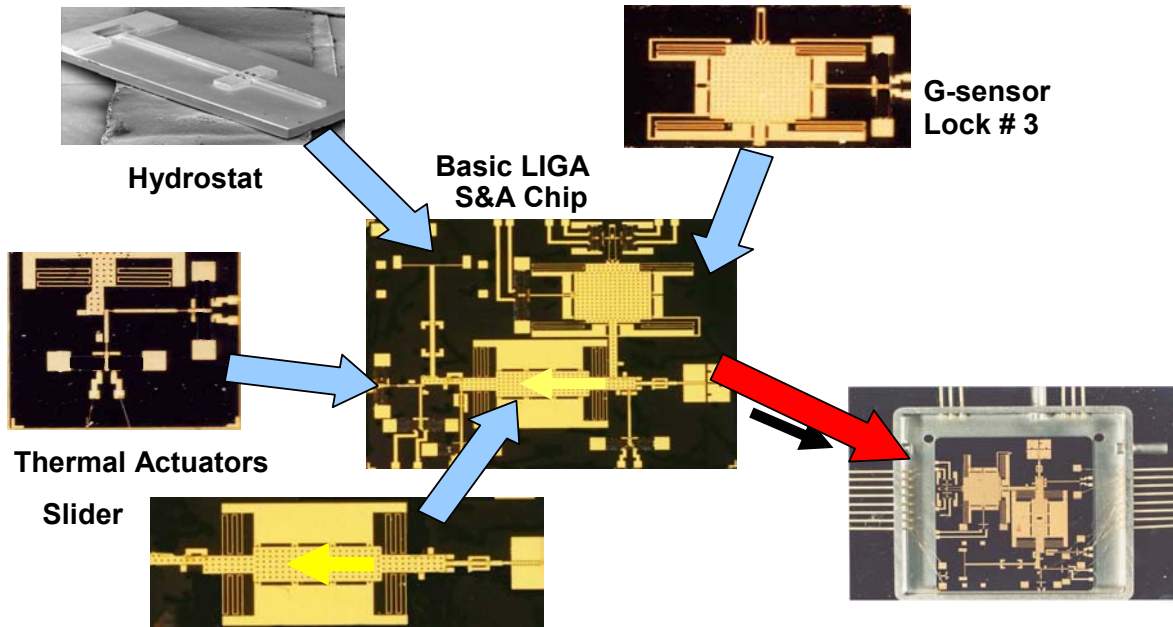

Figure 3.

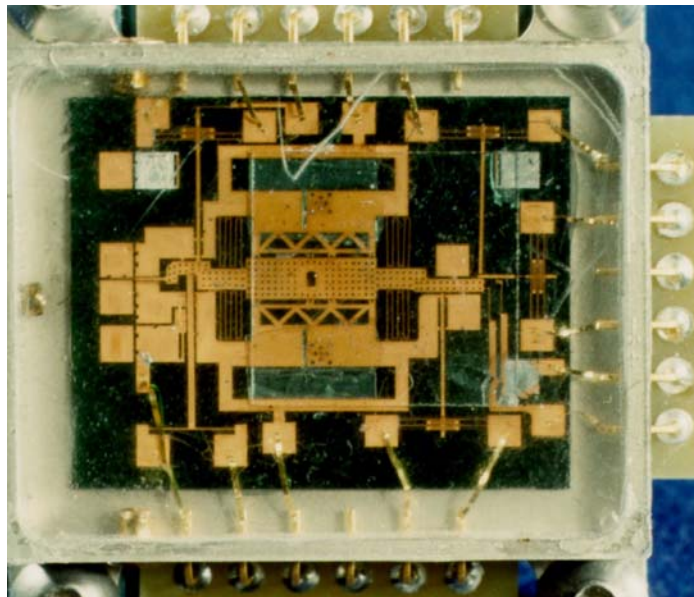

Figure 4.

After a series of laboratory screening test, two sea tests were conducted in summer of 2000. The device was subjected to a variety of real world environments such as transportation by truck over non-paved roads, shipboard handling, launch shock, and torpedo vibration. The device under test was inert but did contain a

MEMS Based Fuzing/Safety and Arming Systems

witness block to record functioning of the EFI. Following the sea test, explosive test were conducted to demonstrate the system ability to create a detonation if the barrel was aligned with the slapper and to demonstrate that no initiation occurred if the barrel was not aligned. The test clearly demonstrated the ability of MEMS based system to operate in real world environments and to perform arming operations for an EFI system.

The slider/barrel can be moved once the three locks are removed. The slider/barrel had to travel several hundred microns against a restoring spring force. An actuator that had both the force and the throw was not available. The task was accomplished by a series of small steps locking the slider/barrel between each movement, similar to pulling a rope by hand. When the locks are removed, the BRAKE is applied. The PULLING actuator is engaged to teeth on the slider via an ENGAGE actuator. The BRAKE is released and the pulling actuator moves the slider. The BRAKE is re-applied and the ENGAGE actuator releases the pulling arm. The arm spring back. The ENGAGE actuator re-engages the teeth on the pulling actuator to teeth on the slider and BRAKE is released, the sequence is repeated until the desired throw is accomplished.

As MEMS technology develops there continues to be many challenges for the designers. In order to accomplish the S&A goals we needed to design a chip that utilized all three-fabrication techniques. This challenge was met by working closely with fabrication foundries to develop a successful process flow. A second challenge is integrating explosives into the MEMS package. This required the design and construction of a clean room capable of meeting both clean room and explosive standards. For example the standard ESD polyester clean room gowns do not meet the conductivity or the fire retarding requirements for explosive handling. The explosive certified cotton gowns do not meet the low shedding requirement for clean room. Using technologies adapted from the space refueling and auto racing a Nomex suit/booties with conductive grid was designed to meet both sets of requirements. Current challenges are in the field of packaging where the device needs to be ported for input such as pressure, high voltage strip lines, fiber optics and explosive output but sealed to control humidity, organic out-gassing.

The next generation devices will make greater use of optical devices to transfer energy and shorten arming times. Ultimately there is a need to develop technology to allow energetic to be fully integrated onto the silicon wafer during fabrication as opposed to manual pellet insertion into bulk-etched cavities. When this challenge is met the S&A size and cost will be significantly reduced allowing wider use of the technology into device that currently do not have sophisticated S&A devices.

The Defense Advanced Research Projects Agency (DARPA) created the graphic shown in figure 5. It is a view of the future and where MEMS can take us. It is a plot of the number of transistor vs. the number of mechanical components or the ability to process data vs. the ability to move or control. Life up until now has been lived on the major axes. Computers are high on the vertical axis, while airplanes and cars are high on the horizontal axis. MEMS technology offers us a life in the first quadrant. The ability to sense, compute and act on an unimagined scale.

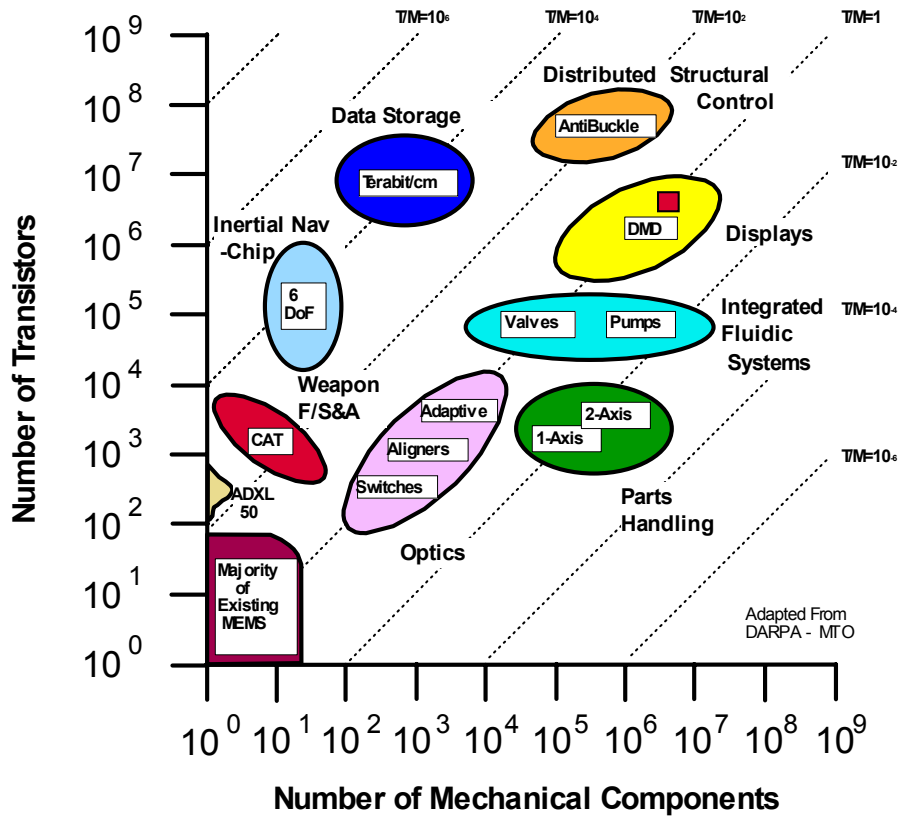

Figure 5.



Office of Naval Research
Code 333



Indian Head Division
Naval Surface Warfare Center
Code 40



Defense Advanced
Research Project Association
ETO

