

D 201725

NASA Technical Memorandum 100946

Refractory Metal Alloys and Composites for Space Power Systems

DISTRIBUTION STATEMENT A
Approved for Public Release
Distribution Unlimited

Joseph R. Stephens, Donald W. Petrasek,
and Robert H. Titran
Lewis Research Center
Cleveland, Ohio

BEST AVAILABLE COPY

20040817 021

Prepared for the
Spring Meeting of the Materials Research Society
Reno, Nevada, April 4-9, 1988

NOTE
DTIC SEP ADD 2006110
D ADD 201725 -
Approved



PLEASE RETURN TO: 1870-10

**BMD TECHNICAL INFORMATION CENTER
BALLISTIC MISSILE DEFENSE ORGANIZATION
7100 DEFENSE PENTAGON
WASHINGTON D.C. 20301-7100**

U01513

REFRACTORY METAL ALLOYS AND COMPOSITES FOR SPACE POWER SYSTEMS

Joseph R. Stephens, Donald W. Petrusek, and Robert H. Titran
National Aeronautics and Space Administration
Lewis Research Center
Cleveland, Ohio 44135

ABSTRACT

Space power requirements for future NASA and other United States missions will range from a few kilowatts to megawatts of electricity. Maximum efficiency is a key goal of any power system in order to minimize weight and size so that the space shuttle may be used a minimum number of times to put the power supply into orbit. Nuclear power has been identified as the primary power source to meet these high levels of electrical demand. One method to achieve maximum efficiency is to operate the power supply, energy conversion system, and related components at relatively high temperatures. NASA Lewis Research Center has undertaken a research program on advanced technology of refractory metal alloys and composites that will provide base line information for space power systems in the 1900's and the 21st century. Basic research on the tensile and creep properties of fibers, matrices, and composites will be discussed.

INTRODUCTION

The objective of our research on refractory metals is to provide an understanding of their behavior and capabilities under conditions that simulate advanced space power system requirements. Current research is focused on monolithic materials to identify alloys that may meet the demands of near term space power components. In addition, refractory metal alloys are being considered for matrices and fibers to be used in metal matrix composites developed for more long term needs that will have to be met in the late 1900's or in the 21st century. These alloys and composites are anticipated to be used in heat generation systems in such applications as cladding for nuclear fuel pins, for heat pipes and tubing, and in energy conversion systems such as the Stirling engine for heater heads, regenerators, pressure vessels, and heat pipes.

The research activities underway on the refractory metals are conducted primarily in-house with some supporting research being done on university grants. The purpose of this paper is to present a summary of our research activities currently underway and to briefly describe the future direction of our research.

SPACE POWER MATERIALS NEEDS

Current spacecraft require electrical power in the few hundred watts to about 75 kWe range as shown in Fig. 1.¹ The former NASA Skylab operated with a little over 10 kWe of electrical power. In contrast, the Space Station, NASA's next major space system is anticipated to require nearly 100 kWe initially and to grow to meet ever increasing demands to several hundred kilowatts of electric. Future missions being planned under the Civilian Space Technology Initiative and Pathfinder, which include a lunar base or a manned flight to Mars, are expected to push the power requirements to even higher

levels as shown in the figure such that tens to hundreds of megawatts of electrical power will be needed.

Possible sources for the power levels described previously are shown in Fig. 2.² For lives of over a year and power levels of less than 10 kWe, solar or radioisotope power sources have been used by the United States. In 1965, the United States successfully launched SNAP-10A, the first nuclear reactor to be operated in space. Since then the Soviet Union has used reactors routinely in low, short-term orbits. It can be seen from this figure, that for the 7- to 10-year lives and power requirements anticipated for future systems, nuclear power is the only power source that can be considered.

A joint NASA, DOD, and DOE program to develop a space nuclear reactor capability is currently under way called SP-100.³ Initially this was envisioned as a 100 kWe Space Power nuclear reactor; hence, SP-100. Since then, the program has focused on demonstrating a Ground Engineering System (GES) at an increased power level of approximately 300 kWe. This program is managed by the Jet Propulsion Laboratory of NASA and a contract has been awarded to GE to design and build the GES. It is anticipated that the SP-100 type of reactor will be able to support a broad spectrum of space activities that will require large amounts of electrical power including communications, navigation, surveillance, and materials processing. Some of the material related constraints for SP-100 are listed in Fig. 3 and include the use of liquid lithium reactor coolant, 1350-K, 7-year, 1-percent strain design criteria, and a 3000-kg system weight that can be launched by the space shuttle. Based on these constraints, we have undertaken an advanced technology program to allow for future growth of the current power level envisioned for SP-100.

Another high temperature materials need is in the energy conversion system for the high electrical power levels that are being considered. Both

the Brayton and Stirling systems are under consideration to convert the heat energy, whether solar or nuclear, into electrical energy.^{4,5} NASA Lewis has paved the way for Stirling engine technology both for terrestrial and space applications. Shown in Fig. 4 is a cross section of a free-piston space power demonstrator engine that will deliver 25 kWe.⁶ This engine operates at a lower temperature than the 1300 K that is anticipated for SP-100 and therefore uses a molten salt as the heat source for ground demonstration purposes and is constructed of stainless steels, superalloys, and other lower temperature materials. For space applications, refractory metals will be required in such areas as the pressure vessel, heat pipes, heater head, regenerator, and other structural members because of the higher material temperature requirements. The material constraints shown previously in Fig. 3 will have to be met by the refractory metals which will probably be niobium or molybdenum base alloys or composites.

REFRACTORY METAL ALLOY TECHNOLOGY

The SP-100 program has selected Nb-1Zr as the reference material for the GES. NASA Lewis in concert with Oak Ridge National Laboratory (ORNL) and Westinghouse-Advanced Engineering System Division (W-AESD) is conducting a series of studies to define the creep behavior of this alloy so that design engineers will be able to use this alloy with confidence.

It has been determined from further design considerations that Nb-1Zr has marginal strength for the GES. To improve its 1-percent creep resistance, larger grain sizes are being explored, heats with increased tantalum and tungsten contents (but still within the allowable specifications) are under test, and designers are looking at the fuel-pin cladding to try to get as much as possible from this alloy. An alternate approach is to consider a higher strength alloy that will still meet the material constraints for SP-100. We have selected an alloy called PWC-11 with a composition of Nb-0.1Zr-0.1C that

was developed in the 1960's. This alloy has been tested in lithium and has been shown to be compatible under conditions anticipated for SP-100. However, several questions remained to be answered from earlier studies. For example, the weldability of PWC-11 and the subsequent effects on creep properties are not fully characterized, and the long term stability of the carbon precipitates (which are believed to be responsible for the improved strength of this alloy) is not known. We currently have creep tests underway at low stress levels similar to those that may be encountered in SP-100 fuel pin claddings. Both Nb-1Zr and PWC-11 are being tested at 1350 K and a stress of 10 MPa. With tests in excess of 18 000 hr, PWC-11 has not achieved any measurable creep deformation while Nb-1Zr reached 1-percent creep in 11 000 hr. The results to date clearly demonstrate the superiority of PWC-11.

The microstructures of Nb-1Zr and PWC-11 are compared in Fig. 5. After the standard 1-hr, 1475-K anneal, Nb-1Zr has an average grain size of 20 μm with a few precipitates present, which are believed to be ZrO_2 . The microstructure of PWC-11, which had undergone its standard anneal of 1 hr at 1775 K plus 2 hr at 1475 K, is shown in Fig. 5(b). The annealed material had a mixture of elongated grains with an average grain size of 25 μm measured by the circle-intercept method, with an aspect ratio of approximately 5:1. Numerous shapes and sizes of particles were apparent in the microstructure. The morphology ranged from massive 5 μm particles to submicron needle-like particles which appeared to be oriented on slip planes.⁷ The majority of particles were believed to be primary carbides which were formed during the initial solidification and were neither broken up nor dissolved during the sheet rolling process. A typical microstructure of an EB welded PWC-11 test specimen is shown in Fig. 6. The base metal away from the weld was in the annealed condition. The weldment had a columnar structure with the grain size ranging from about 45 to over 200 μm . The weld zone exhibited extensive

second phase precipitation similar to the annealed condition except that the particles appeared to be finer and form cell-like domains within the grains.

The high temperature creep strength of PWC-11 ($>0.5 T_m$), relative to the order of magnitude lower carbon content Nb-1Zr alloy, has been attributed to the presence of very fine precipitates of $(Nb,Zr)_2C$ and/or $(Nb,Zr)C$ ranging in size from 1 to 10 μm in diameter.⁸ As with all precipitation-strengthened alloys, the long term beneficial contribution of the precipitate to high strength is suspect. It has been postulated that welding and/or isothermal aging of the PWC-11 alloy could result in a significant loss (>50 percent) in elevated temperature creep strength.⁹ To verify or disprove this postulation, creep tests were conducted in high vacuum (10^{-7} Pa) at 1350 K and 40 MPa to assess the effects of EB welding on creep strength. The creep curves to approximately 1-percent strain are shown for Nb-1Zr and PWC-11 in Fig. 7. The PWC-11 annealed condition (clearly the most creep resistant state) required about 3500-hr to 1-percent strain. A similarly treated sample with an EB weldment required 2125 hr, about a 30-percent decrease in the time for 1-percent strain. A Nb-1Zr specimen was tested in creep for comparison to the annealed PWC-11 alloy. As shown in Fig. 7, the time for 1-percent creep required about 75 hr, a factor of about 45 compared to the annealed PWC-11 and a factor of about 28 for the welded condition. It should be noted that Nb-1Zr was annealed at 1775 K for this comparison which resulted in a grain size of about 45 μm . This larger grain size compared to only 25 μm for PWC-11 should favor a higher creep strength for Nb-1Zr.

Moore et al. conducted short-time creep rupture tests to further characterize the effects of EB welding on PWC-11.¹⁰ The EB welds in these tests were perpendicular to the test axis. Tests were conducted in a 10^{-5} Pa vacuum at 1350 K after the post-weld heat treatment (1 hr at 1475 K) and after aging at 1350 K for 1000 hr. In all the creep rupture tests of these

specimens, failure occurred in the unaffected base metal (Fig. 8), thus demonstrating that the weld region was stronger.

Based on the creep tests conducted to date, projections have been made for the stress for 1-percent creep in a 7-year time frame and compared to the design requirements for SP-100. The results are shown in Fig. 9. PWC-11 is a factor of four times stronger than Nb-1Zr (20 to 5 MPa at 1350 K) over the SP-100 design temperature range of 1350 to 1380 K and affords excellent growth potential over the present SP-100 design stress criterion.

The strength advantage of PWC-11 over Nb-1Zr was explored in more detail by Grobstein and Titran.⁷ In particular, the concern about overaging of the precipitates during high-temperature exposure for long times was addressed by microstructural characterization of the precipitate (complex carbides) morphology. Several techniques were used including light metallography, scanning and transmission electron microscopy, x-ray diffraction, and chemical analysis of extracted particles. Table I summarizes the results of this study. In the as-rolled condition, the precipitates were relatively coarse, 1 to 10 μm in size, and were found to be hcp Nb_2C . After an initial heat treatment of 1 hr at 1755 K and 2 hr at 1475 K, a different finer precipitate formed. These particles were 0.05 to 0.1 μm in diameter and were determined to be fcc $(\text{Zr},\text{Nb})\text{C}$ with the Zr/Nb ratio approximately 70:30. After approximately 5000 hr at 1350 K ($0.5 T_m$), these fine precipitates almost doubled in size, but did not "overage" and were still effective in pinning dislocations and thus resisting plastic deformation in creep.

REFRACTORY METAL COMPOSITES TECHNOLOGY

The objective of this part of our program is to characterize fibers, matrices, and composites for future space power systems where requirements for several hundred kilowatts to megawatts of electricity will need to be met. This advanced technology program focuses on tungsten fibers and Nb or Nb-1Zr

matrices and thus can be compared directly with results from the GES program on the Nb-1Zr and PWC-11 monolithic alloys. It is anticipated that these composites will enable the technology for advanced space power systems to be more efficient and provide more electrical power by allowing operation at higher temperatures.

Refractory metal alloys have been explored as potential fibers for a variety of matrices.^{11,12} The creep rupture strength is of primary significance for space power applications since the intended use of the material is for long time operations. A secondary consideration is the density of the fiber since there is a design weight criterion for launching into orbit. The ratio of the 100-hr rupture strength to density for a number of potential refractory metal fibers is plotted in Fig. 10 for tests conducted at 1365 and 1480 K. It can be seen that for anticipated growth to higher temperatures, the tungsten-base alloys have the superior properties. The strongest alloys, W-Hf-C and W-Re-Hf-C are not commercially available so two lower strength tungsten fiber compositions were selected for our studies since processing conditions and fiber-matrix interactions can be simulated directly with the tungsten base alloys. The two fibers selected were 218 CS, an example of a lower strength, unalloyed lamp filament alloy and ST300 (W-1.5ThO₂), an example of a stronger, oxide dispersion strengthened alloy. Figure 11 is a plot of the time to rupture as function of stress at 1400 and 1500 K for these two alloys. It should be noted that at the longer times, 1000 to 10 000 hr, the two alloys' strength properties converge at both test temperatures. Based on these results we proceeded to fabricate composites using both fiber compositions in the form of 0.20-mm-diameter wire as the reinforcement material and Nb and Nb-1Zr as the matrix material.

The composites were fabricated using an arc-spray process developed at NASA Lewis which is shown schematically in Fig. 12.¹³ In this process, the

tungsten fibers were wound on a drum using a lathe to accurately align and space them. The drum was inserted into a chamber which was subsequently evacuated and backfilled with argon. The Nb or Nb-1Zr matrix material in the form of 1.59-mm-diameter wire was arc sprayed onto the drum surface by using a pressurized argon gas stream. After spraying, the coated fiber (monotape) was removed from the drum surface, cleaned, cut to size, stacked in three layers plus matrix only arc-sprayed monotapes on either surface, sealed in a container, and hot isostatically pressed (HIPed) to produce unidirectional fiber-oriented composites. HIP processing parameters were optimized for each combination of fiber and matrix to achieve the best possible properties of the composite. Parameters investigated included temperature, time, and pressure and were varied to explore under what conditions insufficient bonding between fiber and matrix occurred and where excessive reaction took place, as depicted schematically in Fig. 13. A typical microstructure of an as-processed ST300/Nb composite, Fig. 14, indicates minimal reaction between the fiber and matrix during the arc spray and HIP processes. One of the principal concerns in the use of composites for long-term, high-temperature applications is the degree of fiber-matrix interaction. Excessive fiber-matrix reaction could degrade the fiber and thus the composite properties. Figure 15 compares the reaction at the fiber-matrix interface that occurred in ST300/Nb-1Zr composites exposed for about 1000 hr at 1400 and 1500 K. The depth of penetration into the 0.2-mm-diameter fiber was less than 0.01 mm. The effects of matrix composition on the depth of penetration are compared in Fig. 16 for ST300 fibers in Nb and Nb-1Zr matrices. After 2500-hr exposure the depth of penetration was about 0.01 mm for both matrices. The values for fiber-matrix reactions are in agreement with previously reported diffusion coefficients in the literature for tungsten-niobium diffusion couples.¹⁴ The results thus indicate good microstructural stability for this composite system.

For the creep rupture investigation, tests were conducted on three-ply, unidirectional flat plates from which tensile specimens were cut by electrical discharge machining. An example of a specimen tested to rupture is shown in Fig. 17. Tungsten tabs were TIG welded on both sides of the ends of the composite specimens to prevent specimen shearing at the pin hole locations. It is also possible to make other shapes by the arc-spray, HIP process, such as the tube illustrated in Fig. 18. Since for nuclear space power systems, fuel clads, along with heat pipes in tubular geometries will be required, the ability to produce composites having this geometry is very significant. Tensile strengths have been determined for the composites at temperatures of interest to advanced space power systems and are also shown in this figure.¹⁵

The primary property requirement for space power system applications however, is adequate creep resistance for long time exposure. Preliminary creep behavior of the composite materials has been determined.¹⁶ A typical creep curve is reproduced in Fig. 19 for a ST300/Nb-1Zr composite tested at 1400 K under an applied stress of 180 MPa. The creep curves for these composites exhibit the characteristic three-stage creep behavior typical of tungsten and other metals and alloys at elevated temperatures. The strain to rupture ranged from 5 to 7 percent for the composite materials tested in this program.

The fracture surfaces of composite specimens were examined using scanning electron microscopy. Figure 20 shows the fracture surface of a ST300/Nb-1Zr composite where it should be noted that both the fiber and the matrix failed in a ductile manner in creep-rupture testing. Further evidence of fiber- and matrix-ductile behavior is shown in the optical micrograph of Fig. 21, where necking of the fiber and matrix can be observed.

The effective use of fiber reinforcements to increase the creep resistance of Nb and Nb-1Zr is shown in Fig. 22. The time to cause 1-percent strain for

arc-sprayed niobium under an applied stress of 20 MPa was 17 hr, while arc-sprayed niobium reinforced with 40-vol-% ST300 fiber and stressed at an order of magnitude higher stress (200 MPa) had nearly an order of magnitude increase in the time to reach 1-percent strain. Increasing the fiber content results in further increases in creep resistance as shown for the 50-vol-% fiber content ST300/Nb-1Zr composite.

Since the reinforcing fibers have a density over twice that of Nb, the 50-vol-% composite is over one and a half times heavier than niobium, and thus density must be taken into consideration when making property comparisons. A comparison of the creep stress to density ratio for 1-percent strain for the composites, PWC-11, and Nb-1Zr is made in Fig. 23. On this density corrected basis, the composites are over an order of magnitude stronger than Nb-1Zr and three and a half to four times stronger than PWC-11 at both test temperatures, 1400 and 1500 K.

A comparison of the minimum creep rates of the composites tested at 1400 and 1500 K with that for the arc-sprayed niobium monolithic material tested at 1400 K is made in Fig. 24. It is evident that the composites creep at a much lower rate than the niobium matrix material. Noting that the strain- and strain-rate compatibility must be maintained at the fiber-matrix interface during creep of a composite subjected to uniaxial loading, it is possible to estimate the relative magnitude of the stress on the matrix using Fig. 24. For example, it is evident from Fig. 24 that at 1400 K the ST300/Nb composites exhibit a minimum creep rate of about $1 \times 10^{-8} \text{ sec}^{-1}$ at 250 MPa. Using the strain-rate compatibility arguments, the data in Fig. 24 suggest that a stress of about 15 MPa would enable the niobium matrix to creep at the same rate. It can be shown using the rule of mixtures, that the corresponding stress on the matrix is only about 3 percent of the total applied stress acting on a composite containing 50-vol-% fibers. This means a first order prediction of

creep behavior of the composites can be described by the creep equations for the reinforcing fibers. The minimum creep rate of the composites can thus be equated to the power creep behavior as follows:

$$\dot{\epsilon}_m = A \exp\left(\frac{-Q}{RT}\right) \sigma^n$$

$$\sigma = \sigma_f = \frac{\sigma_c}{V_f}$$

$$\dot{\epsilon}_m = A \exp\left(\frac{-Q}{RT}\right) \left(\frac{\sigma_c}{V_f}\right)^n$$

where

- σ_c the stress on the composite
- σ_f the stress on the fiber assuming that the fiber carries the total load
- V_f the volume-fraction-fiber content
- Q the apparent activation energy
- n the creep-rate stress exponent
- A a constant for the fiber

The calculated composite creep activation energy Q of 465 to 490 kJ/mol agrees with results for other forms of tungsten tested in this temperature range. It has been proposed that the creep of as-drawn fibers occurs by a dislocation mechanism controlled by grain boundary or pipe diffusion.¹⁷ The creep-rate exponent n for the ST300-reinforced composites ranged between five and six, which in agreement with values predicted by simple theories of dislocation climb where n is about five. It is unlikely that grain boundary diffusion creep or grain boundary sliding controls creep because of the oriented grain structure of the fibers.

The relationship between rupture life of the ST300-fiber-reinforced composites and the minimum creep rates is shown in Fig. 25 where a linear inverse relationship was observed of the form:

$$t_R = \frac{C}{\dot{\epsilon}_m}$$

where $C = 0.036$. This relationship has been observed in other metallic materials and is known as the Monkman-Grant relationship.¹⁸ This relationship was found to be valid for stainless steel composites reinforced with tungsten-thoria fibers and for nickel-coated and uncoated tungsten-thoria wires.^{19,20} The C value of 0.036 observed in this investigation compares favorably with the value of 0.0207 observed for the nickel-coated and uncoated fibers. The minimum creep-rate expression (previously described for the composites) can be substituted in the Monkman-Grant relationship to yield an expression which equates the composite rupture life with the stress on the composite and with the volume-fraction-fiber content as follows:

$$\frac{1}{t_R} = \left(\frac{1}{C}\right) A \exp\left(\frac{-Q}{RT}\right) \left(\frac{\sigma_C}{V_f}\right)^n$$

This expression indicates that at a constant applied stress on the composite, increasing the fiber-volume-fraction content will result in increased rupture life values for the composite.

Advanced space power system components are projected to require lives ranging from 7 to 10 years. In the interest of determining the potential of the composite materials for such applications, projections were made for both the 1000- and 100 000-hr (11.4 years) density-corrected creep stress to yield 1-percent strain at 1400 and 1500 K and these were compared with similar projections for PWC-11 and Nb-1Zr, Fig. 26. These projections show that the composites are an order of magnitude stronger than Nb-1Zr at 1400 and 1500 K. Compared to PWC-11, the composites are five to six times stronger at 1400 K and three to five times stronger at 1500 K. The strength to density values projected for the composites indicate a potential mass savings that could be

realized by use of the composites to replace thicker sections of Nb-1Zr. Alternatively, the potential for increased service temperatures of components can be considered.

FUTURE RESEARCH

The results to date show that for the GES, PWC-11 has attractive creep properties that will extend the capabilities of SP-100 compared to a similar system fabricated from Nb-1Zr. However, additional research is needed in the areas of alloy processing, chemistry control, and heat treatment; establishing uniaxial- and biaxial- (tube) creep data bases; long term aging effects in vacuum and lithium; joining process development; and irradiation testing. Our emphasis on advanced materials for future space power systems will continue to focus on the tungsten-reinforced niobium-alloys composite materials. Follow-on research will explore the effects of angle plys on creep behavior, fiber-matrix reactions, alternate fibers such as molybdenum base alloys to reduce composite density, and matrix alloying to minimize fiber-matrix reaction.

SUMMARY

The results to date from our research in support of the Ground Engineering System for SP-100 and our advanced materials technology program for future space power systems can be highlighted as follows:

1. Based on its demonstrated strength advantage, PWC-11 (Nb-1Zr-0.1C) has been selected for the SP-100 reference flight system over the weaker Nb-1Zr alloy.
2. Based on creep rupture and compatibility at 1500 K, tungsten fibers are potential reinforcements for Nb-base alloys for space power systems.
3. Tungsten-reinforced Nb-1Zr composites provide a ten-fold and a four-fold creep strength advantage over Nb-1Zr and PWC-11, respectively, at 1400 to 1500 K.

REFERENCES

1. J.G. Slaby, 1988 Overview of Free-Piston Stirling Technology for Space at the NASA Lewis Research Center, NASA TM-100795 (1988).
2. SP-100 Space Reactor Safety, DOE/NE-0083, 1987.
3. R.H. Cooper Jr. and E.E. Hoffman, eds., Refractory Alloy Technology for Space Nuclear Power Applications, CONF-8308130, DOE, 1984.
4. R.E. English, Speculations on Future Opportunities to Evolve Brayton Power Plants Aboard the Space Station, NASA TM-89863, 1987.
5. G.R. Dochat, Free-Piston Stirling Engine for Space Power, Proceedings of the Twenty-Second Automotive Technology Development Contractors' Coordination Meeting. SAE P-155, Society of Automotive Engineers, Warrendale, PA, 1984, pp. 209-213.
6. D.R. Hull, D.L. Alger, T.J. Moore, and C.M. Scheuermann, Fatigue Failure of Regenerator Screens in a High Frequency Stirling Engine, NASA TM-88974, Mar. 1987.
7. T.L. Grobstein and R.H. Titran, Characterization of Precipitates in a Niobium-Zirconium-Carbon Alloy, DOE/NASA/16310-6, NASA TM-100848, 1988.
8. Advanced Materials Program for November and December 1964, PWAC-1018, Pratt & Whitney Aircraft Corp., Middletown, CT (1965).
9. R.H. Titran, T.J. Moore, and T.L. Grobstein, Creep Properties of PWC-11 Base Metal and Weldments as Affected by Heat Treatment, NASA TM-88842 (1986).
10. T.J. Moore, R.H. Titran, and T.L. Grobstein, The Effect of Electron Beam Welding on the Creep Rupture Properties of a Nb-Zr-C Alloy, NASA TM-88892, DOE/NASA 16310-1 (1986).

11. D.W. Petrusek and R.A. Signorelli, Stress-Rupture and Tensile Properties of Refractory-Metal Wires at 2000° and 2200°F (1093° and 1204°C), NASA TN D-5139 (1969).
12. D.W. Petrusek, High-Temperature Strength of Refractory-Metal Wires and Consideration for Composite Applications, NASA TN D-6881 (1972).
13. L.J. Westfall, Tungsten Fiber Reinforced Superalloy Composite Monolayer Fabrication by an Arc-Spray Process, NASA TM-86917 (1985).
14. F.G. Arcella, Interdiffusion Behavior of Tungsten or Rhenium and Group V and VI Elements and Alloys of the Periodic Table, Part I, NASA CR-134490 (1974).
15. L.J. Westfall, D.W. Petrusek, D.L. McDanel, and T.L. Grobstein, Preliminary Feasibility Studies of Tungsten/Niobium Composites for Advanced Space Power Systems Applications, NASA TM-87248 (1986).
16. D.W. Petrusek and R.H. Titran, Creep Behavior of Tungsten/Niobium and Tungsten/Niobium-1 Percent Zirconium Composites, NASA TM-100804, DOE/NASA/16310-5, (1988).
17. S.L. Robinson and O.D. Sherby, Acta. Met., 17, 109 (1969).
18. F.C. Monkman and N.J. Grant, ASTM. Proc., 56, 593 (1956).
19. R. Warren and L.O.K. Larsson, Matrix Composition and Fiber/Matrix Compatibility in W-Wire Reinforced Composites. Proceedings of the Scandinavian Symposium in Materials Science, University of Lulea (1980).
20. R. Warren and C.H. Anderson, High Temp. High Press., 14, 41 (1982).

TABLE I. - CHARACTERIZATION OF PRECIPITATES IN PWC-11
(Nb-1Zr-0.1C)^a

	As-rolled	After initial heat treatment	After long-term high-temperature exposure
Size, μm	1 to 10	0.05 to 0.1	0.1 to 0.15
Structure	HCP	FCC	FCC
Composition	Nb ₂ C	(Zr,Nb)C	(Zr,Nb)C

^aConclusions: Aging at 1350 or 1400 K with an applied stress does not "overage" the precipitates. After long times (5000 hr) at 1350 K, the precipitates are still effective at pinning dislocations and resisting plastic deformation in creep.

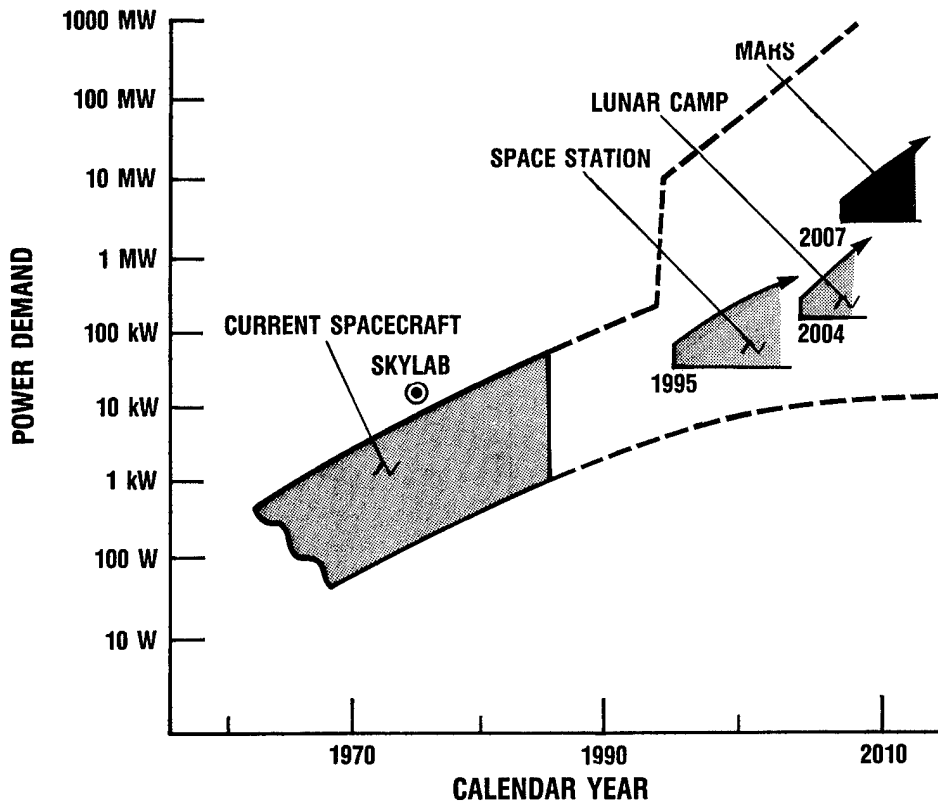
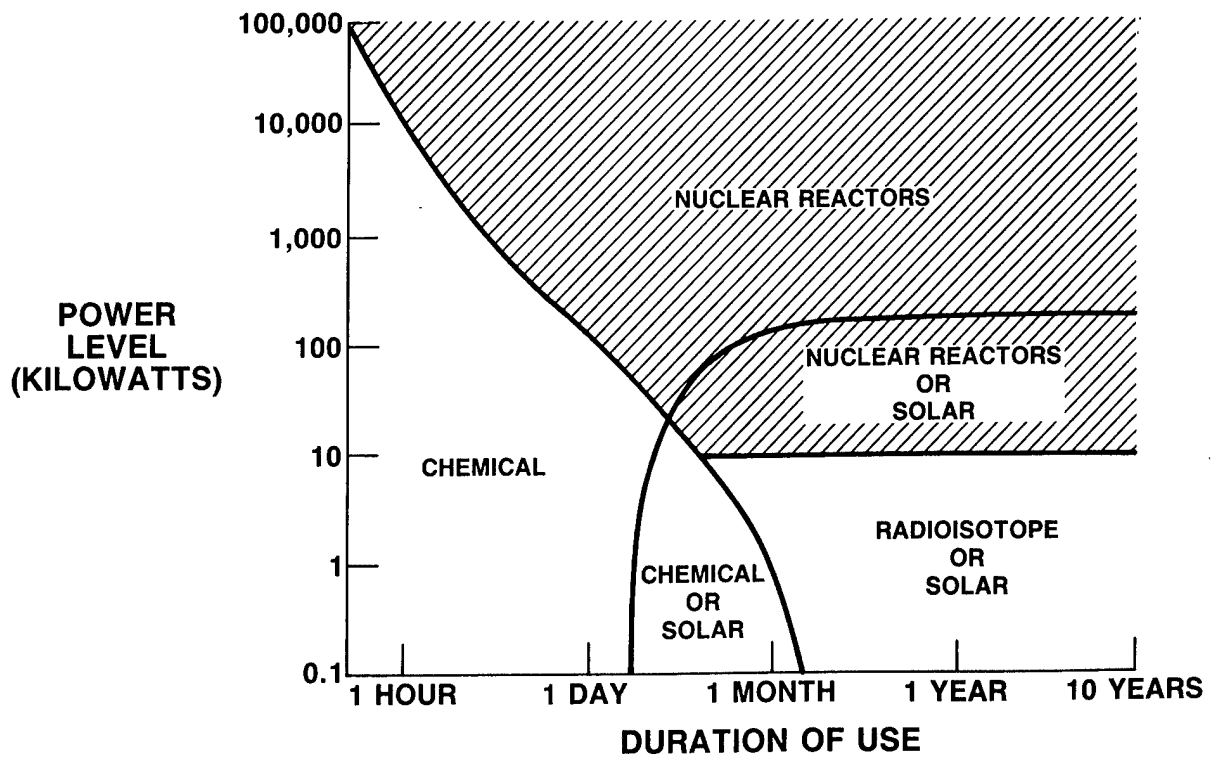
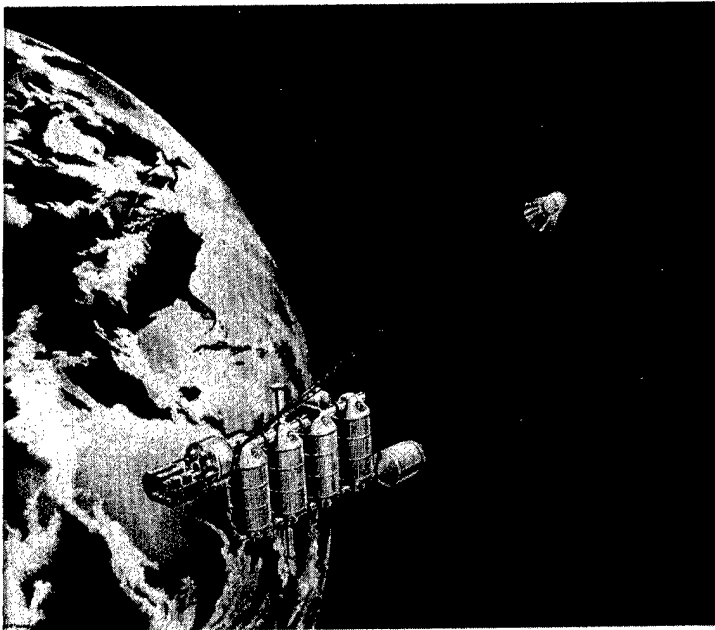

FIGURE 1. - PROJECTED GROWTH IN SPACE POWER.



SP100 SPACE REACTOR SAFETY
DOE/NE0083 MAY 1987

FIGURE 2. - POWER SOURCES FOR SPACE APPLICATIONS.



- MATERIAL CONSTRAINTS**
- LIQUID LITHIUM REACTOR COOLANT
 - 1350 K-7 YEAR-1% STRAIN DESIGN CRITERIA
 - 3000 kg SYSTEM WEIGHT

FIGURE 3. - SP-100 GOAL: TO DEVELOP NUCLEAR POWER FOR SPACE.

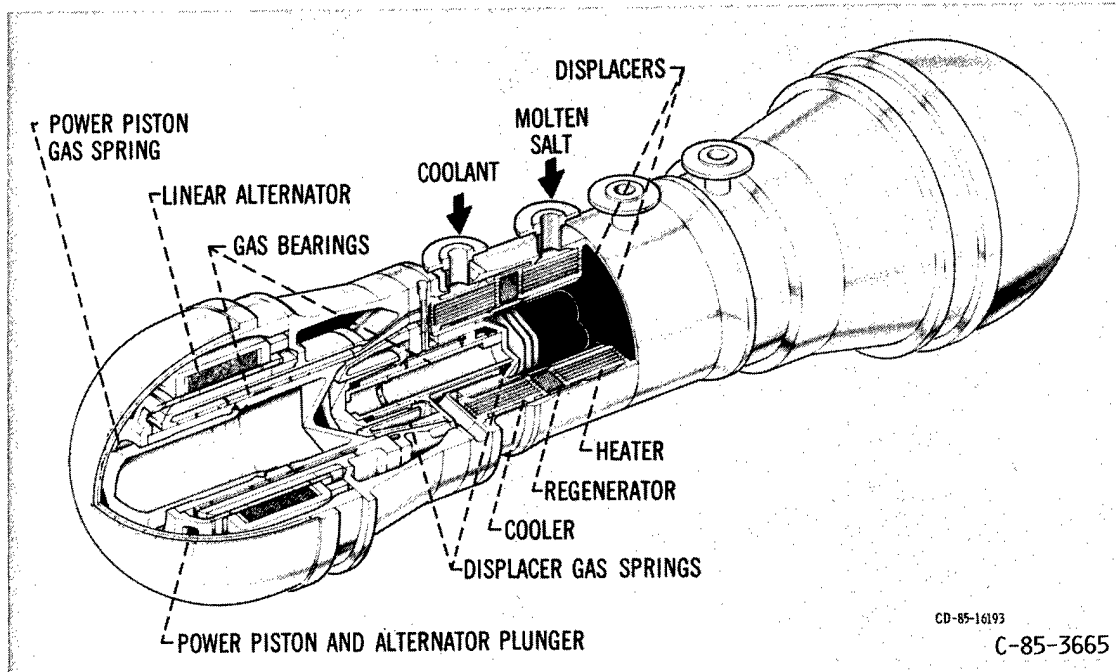
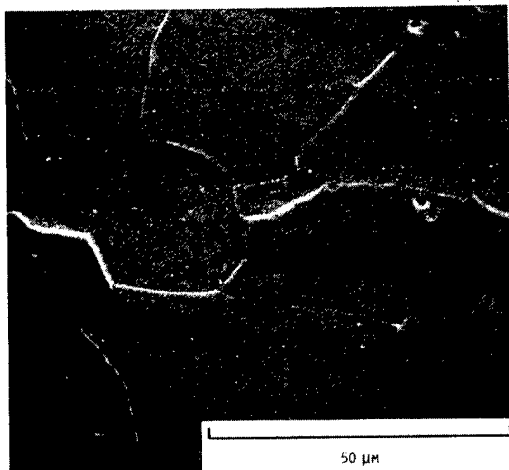

FIGURE 4. - SPACE POWER DEMONSTRATOR ENGINE.

Nb-1Zr
ANNEALED 1 HR-1475 K



PWC-11
ANNEALED 1 HR-1755 K + 2 HRS-1475 K

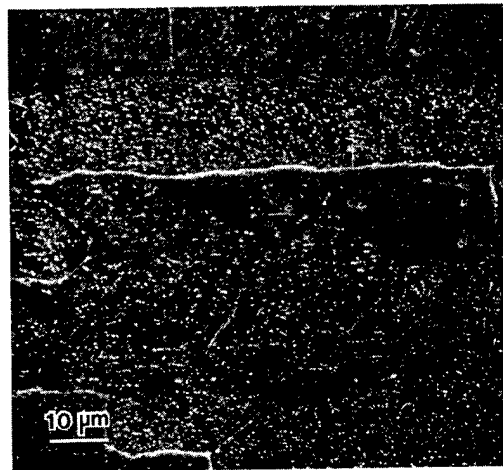
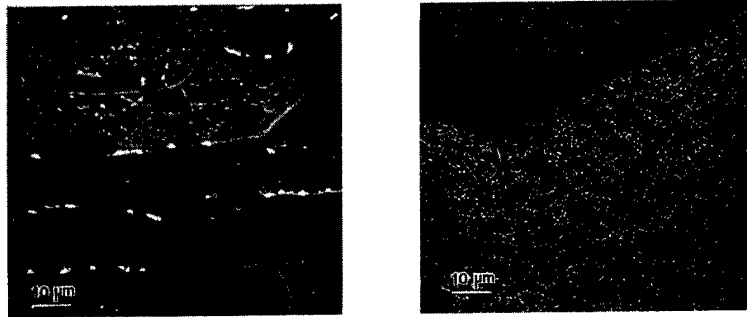
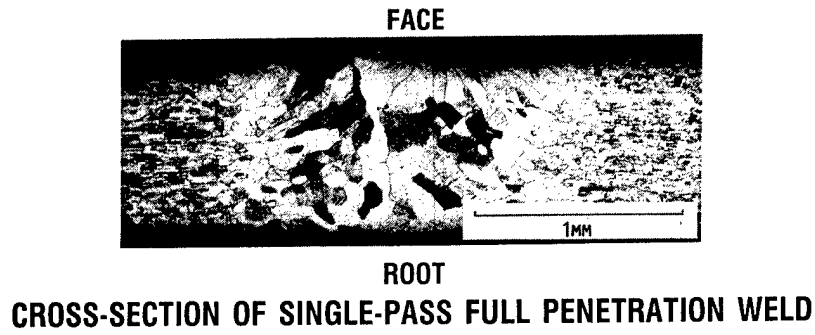

FIGURE 5. - MICROSTRUCTURES OF Nb-1Zr AND PWC-11.



UNAFFECTED BASE METAL

WELD FUSION ZONE

FIGURE 6. - MICROSTRUCTURES OF ELECTRON BEAM WELDED PWC-11.

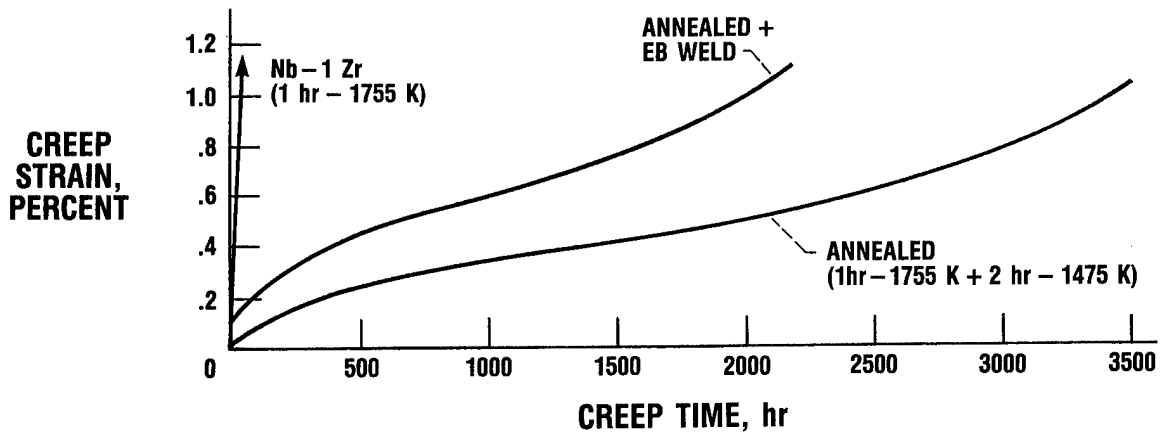

FIGURE 7. - CREEP CURVES OF Nb-1Zr AND PWC-11 AT 1350 K AND 40 MPa.

[NECKING ON BOTH SIDES OF WELD]

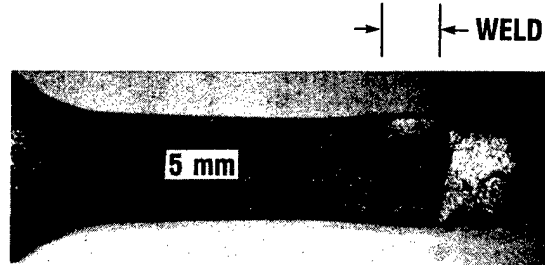

FIGURE 8. - TYPICAL BASE METAL CREEP RUP-
TURE FAILURE IN EB WELDED PWC-11 MATERIAL
TESTED AT 1350 K.

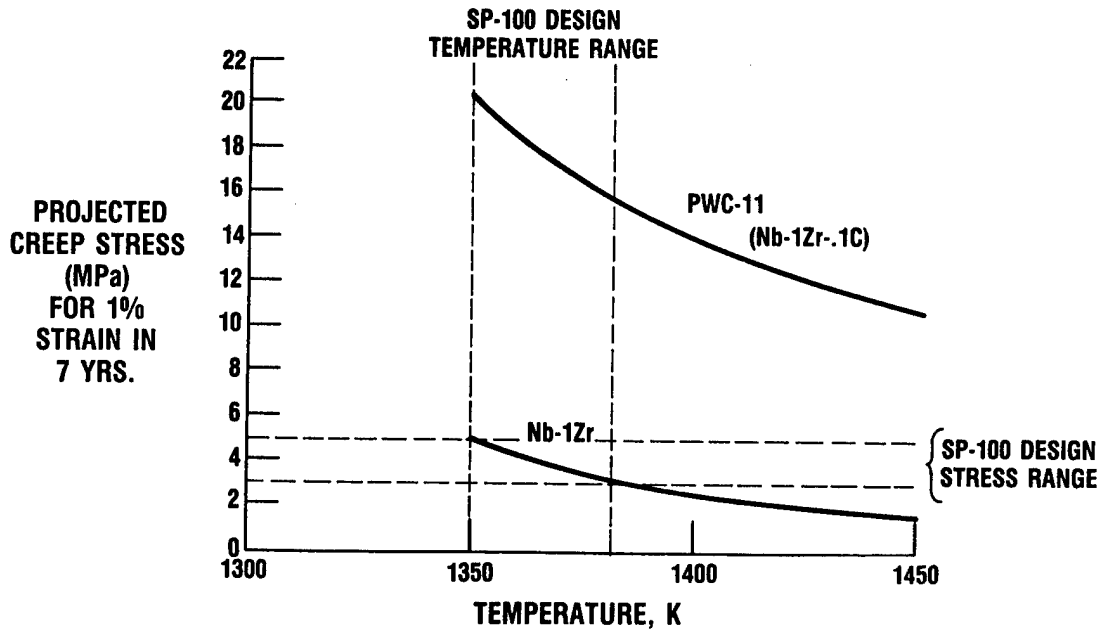

FIGURE 9. - CREEP POTENTIAL OF PWC-11 COMPARED TO Nb-1Zr.

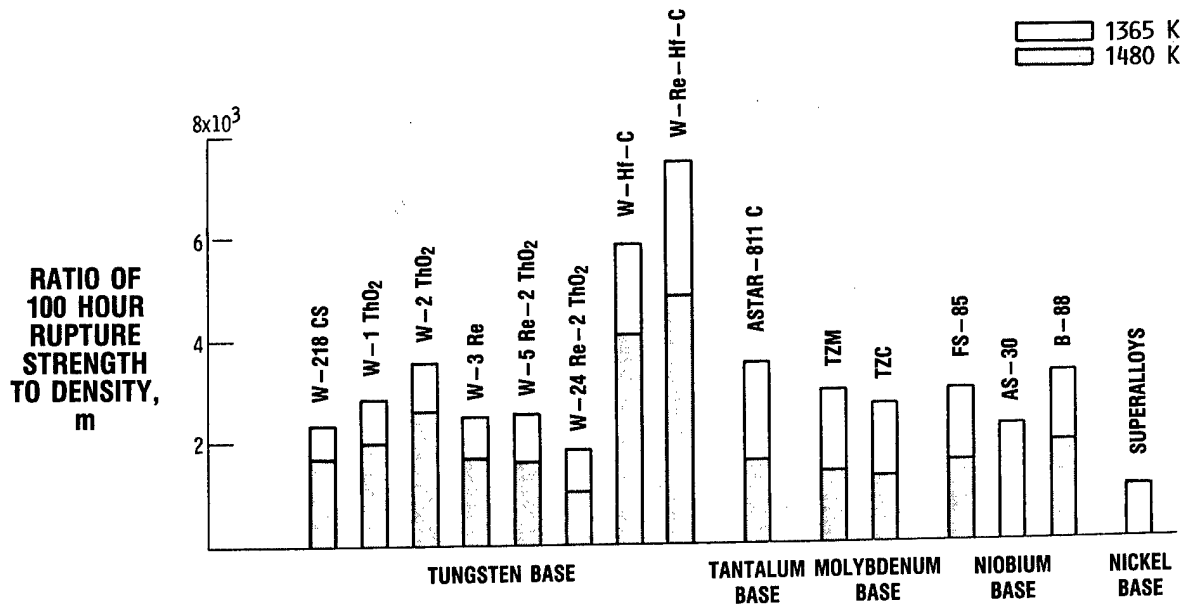

FIGURE 10. - STRENGTH COMPARISON OF CANDIDATE REFRACTORY METAL ALLOY FIBERS.

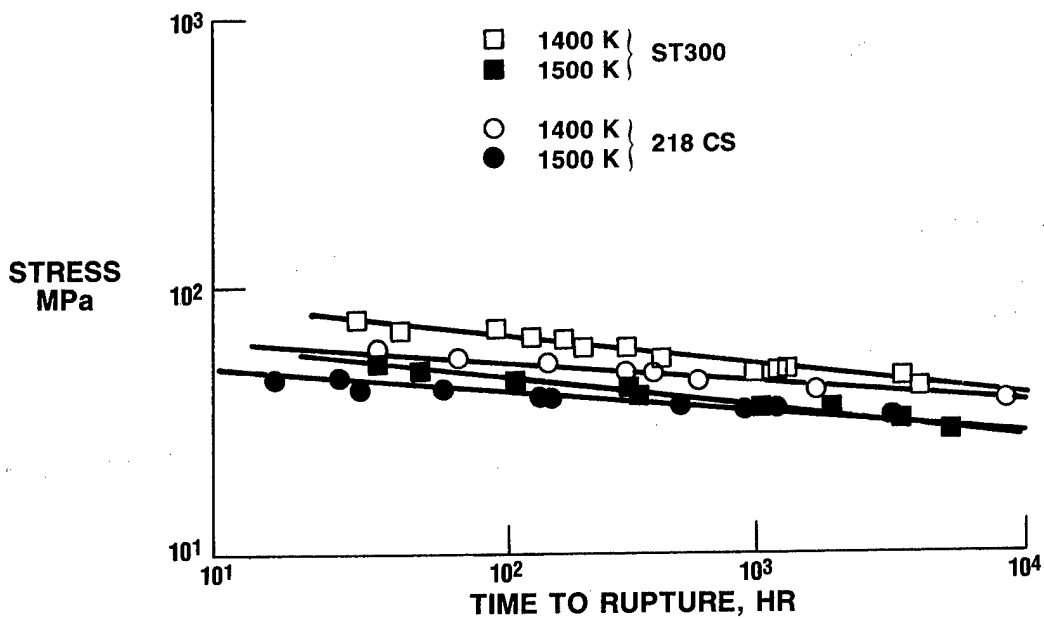

FIGURE 11. - STRESS RUPTURE STRENGTH FOR ST300 (W + 1.5% ThO₂) AND 218 CS FIBERS.

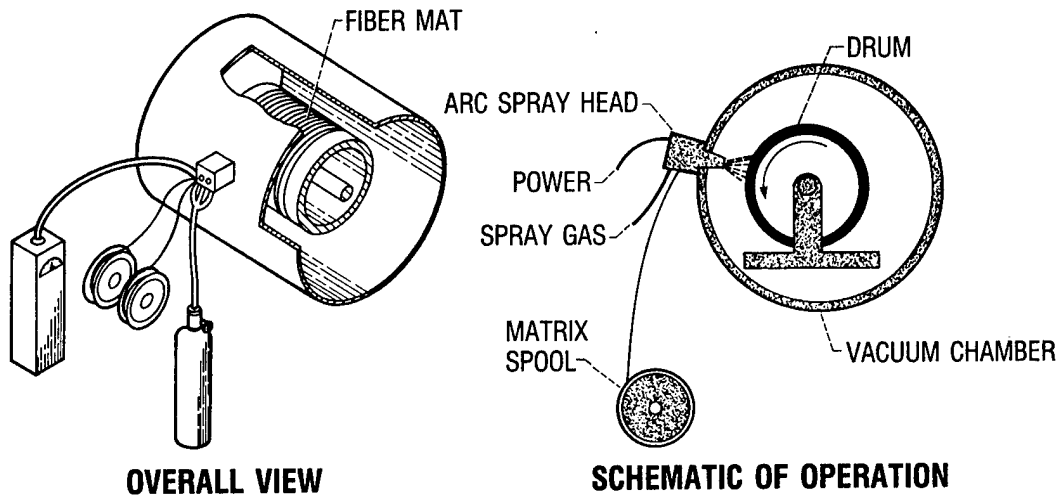

FIGURE 12. - ARC SPRAY MONOTAPE FABRICATION PROCESS.

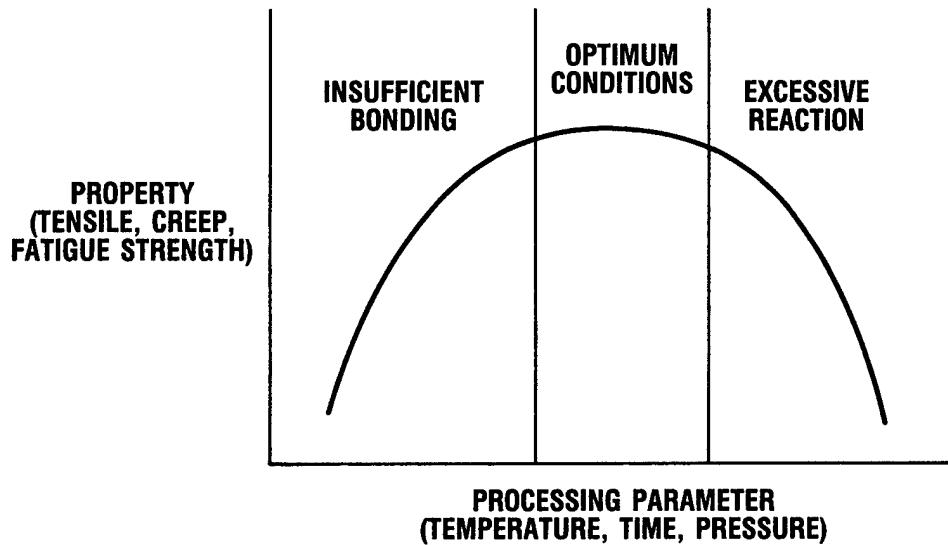
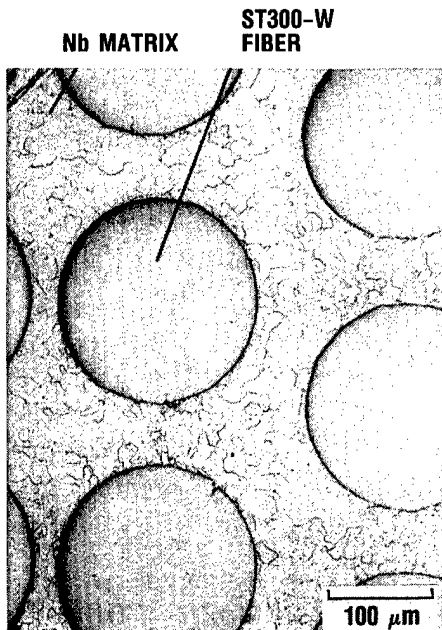
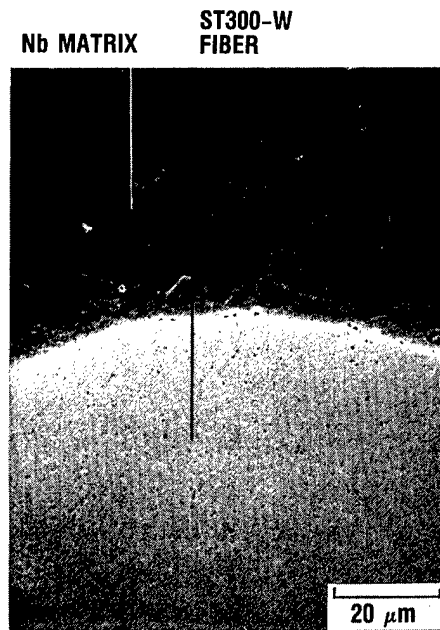

FIGURE 13. - OPTIMIZATION OF FABRICATION PARAMETERS IS CRITICAL TO ACHIEVING MAXIMUM PROPERTIES.



GENERAL ARRAY



FIBER/MATRIX INTERFACE

• NO VISIBLE FIBER/MATRIX INTERFACIAL REACTION

FIGURE 14. - TUNGSTEN FIBER REINFORCED NIOBIUM MATRIX COMPOSITES AS-FABRICATED MICROSTRUCTURE.

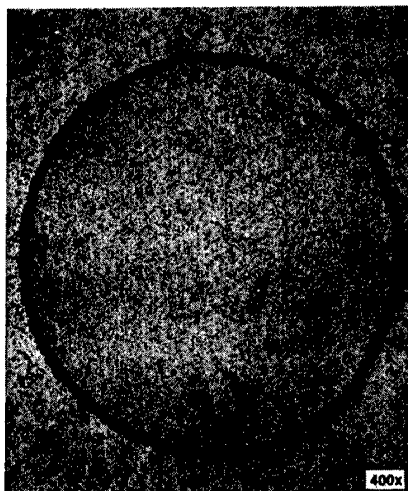

EXPOSED 1104 HRS AT 1400 K

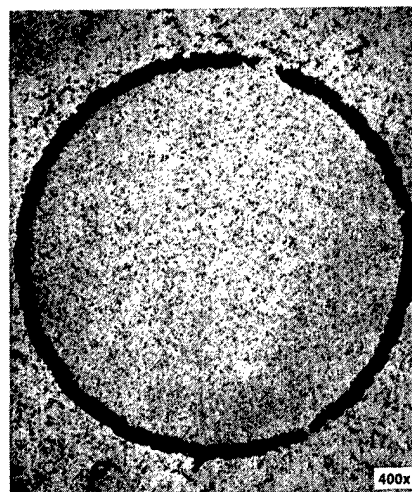

EXPOSED 921 HRS AT 1500 K

FIGURE 15. - ST300/Nb + 1Zr FIBER/MATRIX REACTION.

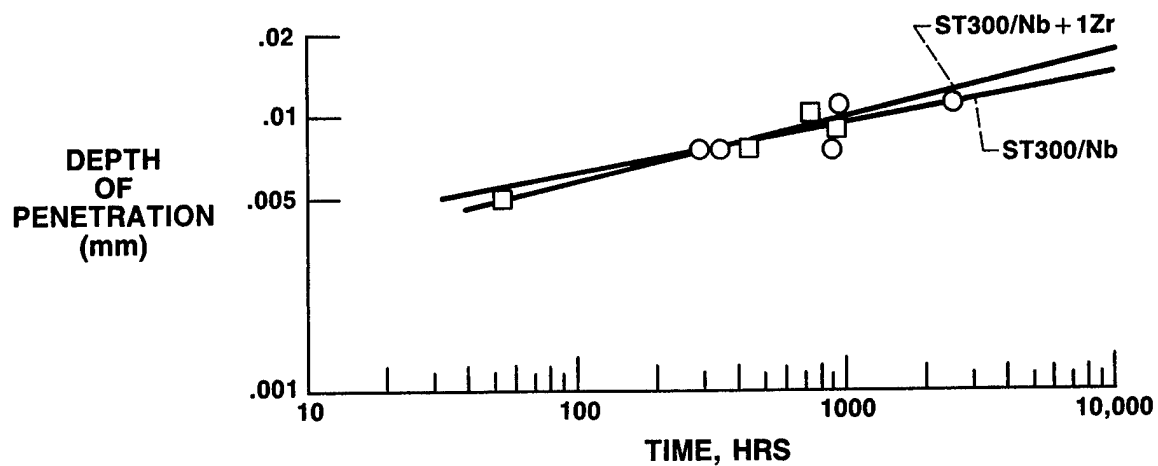

FIGURE 16. - DEPTH OF REACTION PENETRATION VERSUS TIME AT 1500 K.

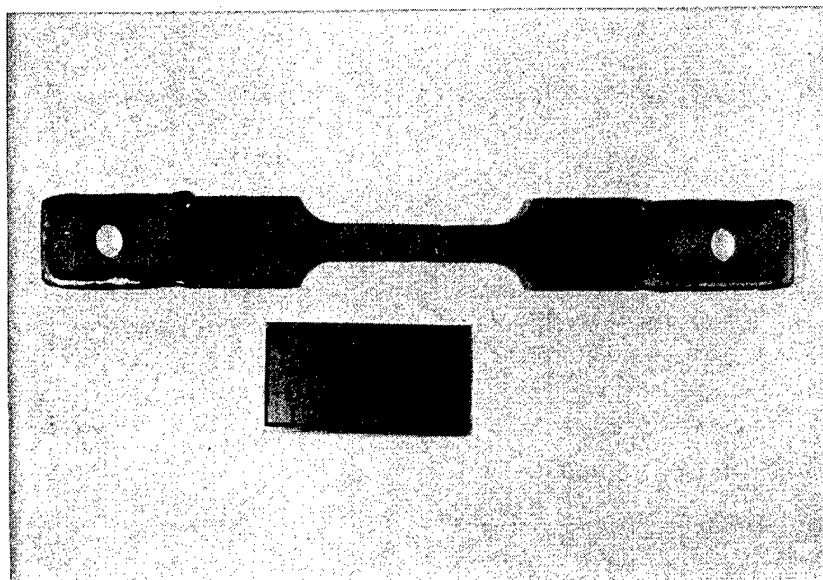
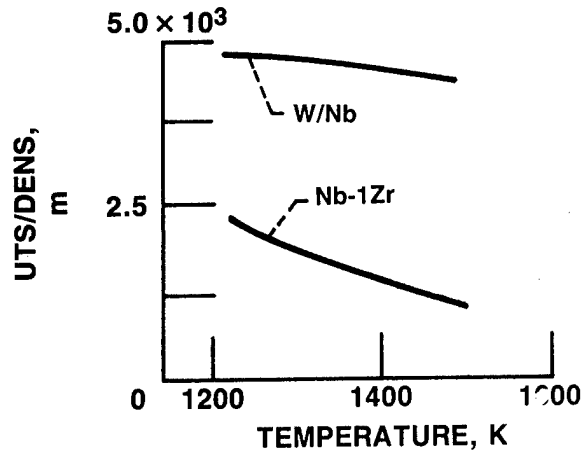
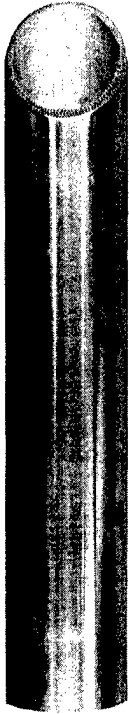

FIGURE 17. - FRACTURED ST300/Nb + 1Zr COMPOSITE CREEP RUPTURE SPECIMEN.



COMPARISON OF TENSILE STRENGTH/DENSITY RATIOS OF W/Nb WITH Nb-1Zr

FIGURE 18. - TUNGSTEN FIBER/NIOBIUM MATRIX COMPOSITE TUBE.

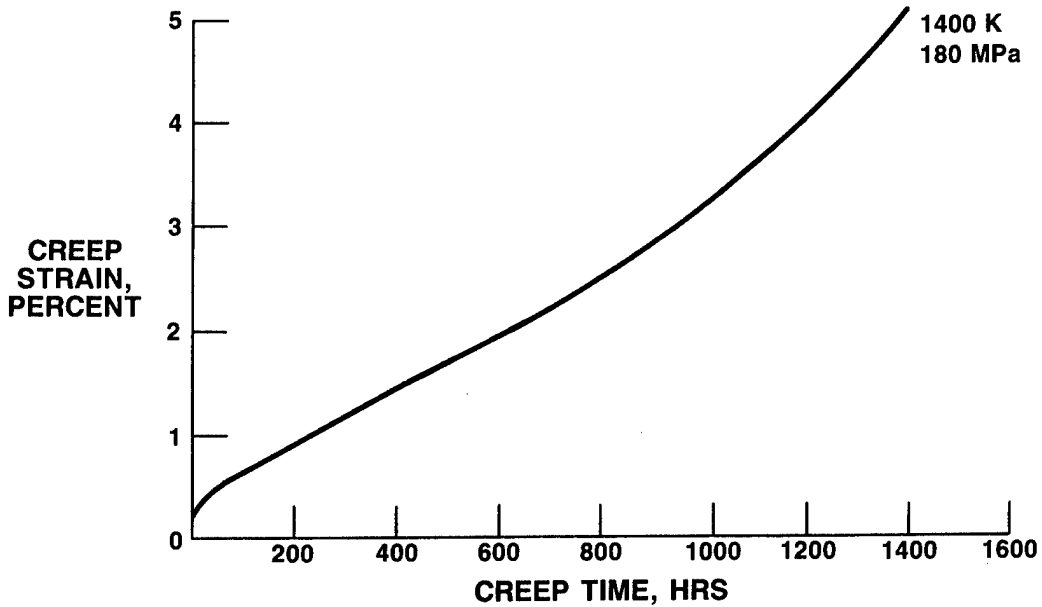
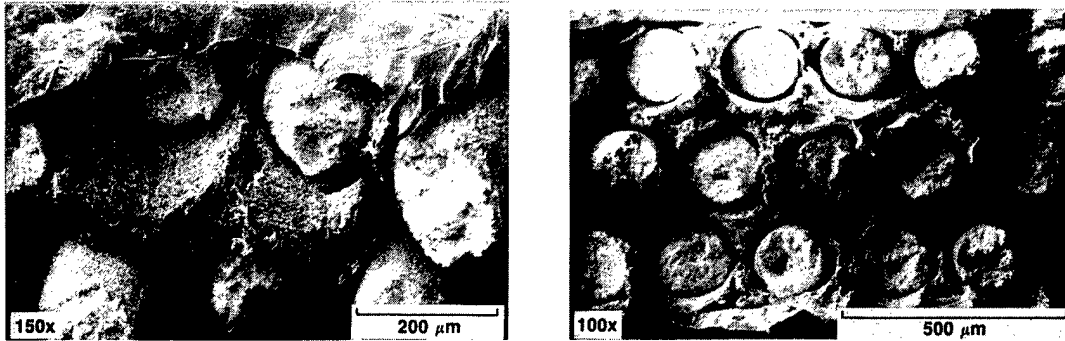

FIGURE 19. - TYPICAL CREEP CURVE FOR ST300/Nb + 1Zr COMPOSITE.



CREEP RUPTURE TEST DATA: 1500 K—150 MPa—284.5 HRS

FIGURE 20. - FRACTURE SURFACE OF ST300/Nb COMPOSITE SPECIMEN.



**CREEP RUPTURE
TEST DATA**

**1400 K
220 MPa
2325 HRS**

FIGURE 21. - FRACTURE SECTION OF ST300/Nb + 1Zr CREEP
RUPTURE SPECIMEN.

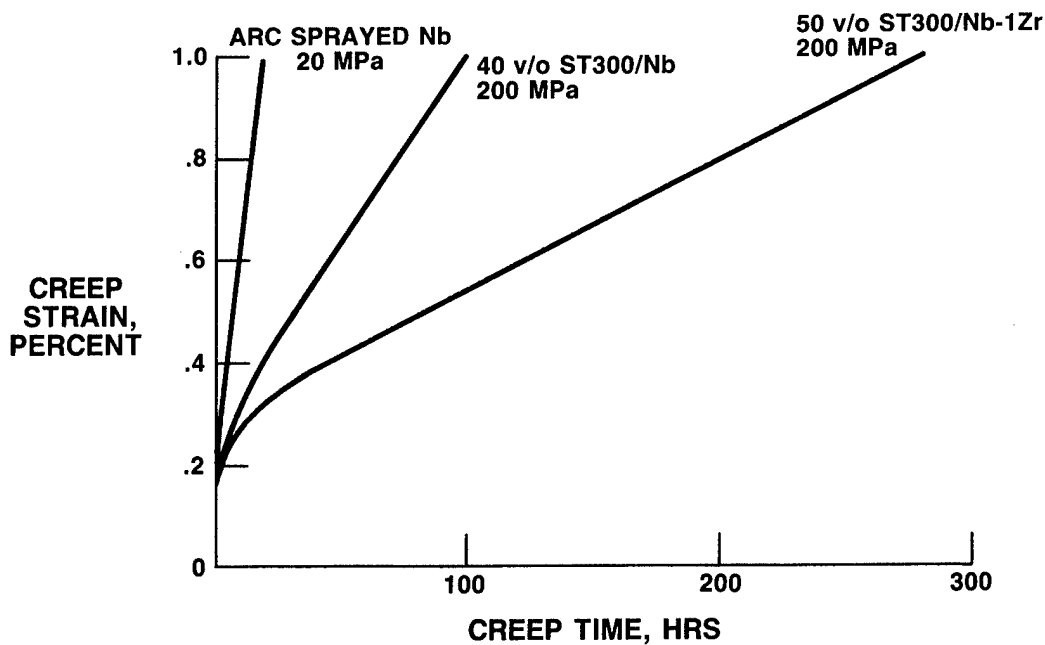

FIGURE 22. - 1400 K CREEP CURVES FOR ST300/Nb AND Nb-1Zr COMPOSITES.

COMPOSITES NORMALIZED TO 50 VOLUME PERCENT FIBER CONTENT

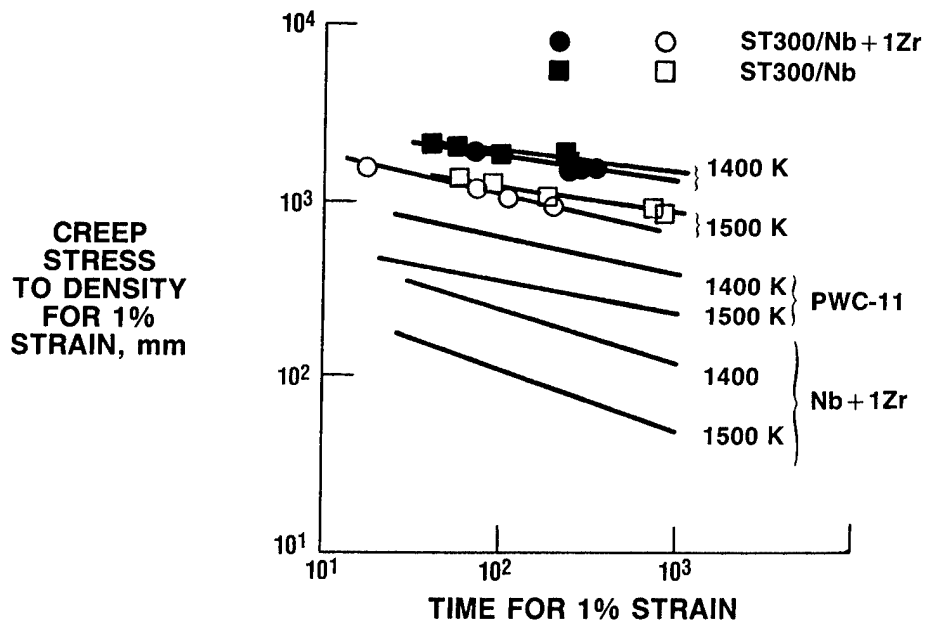

FIGURE 23. - COMPARISON OF CREEP STRESS TO DENSITY RATIO FOR 1% STRAIN FOR COMPOSITES, PWC-11 AND Nb + 1Zr.

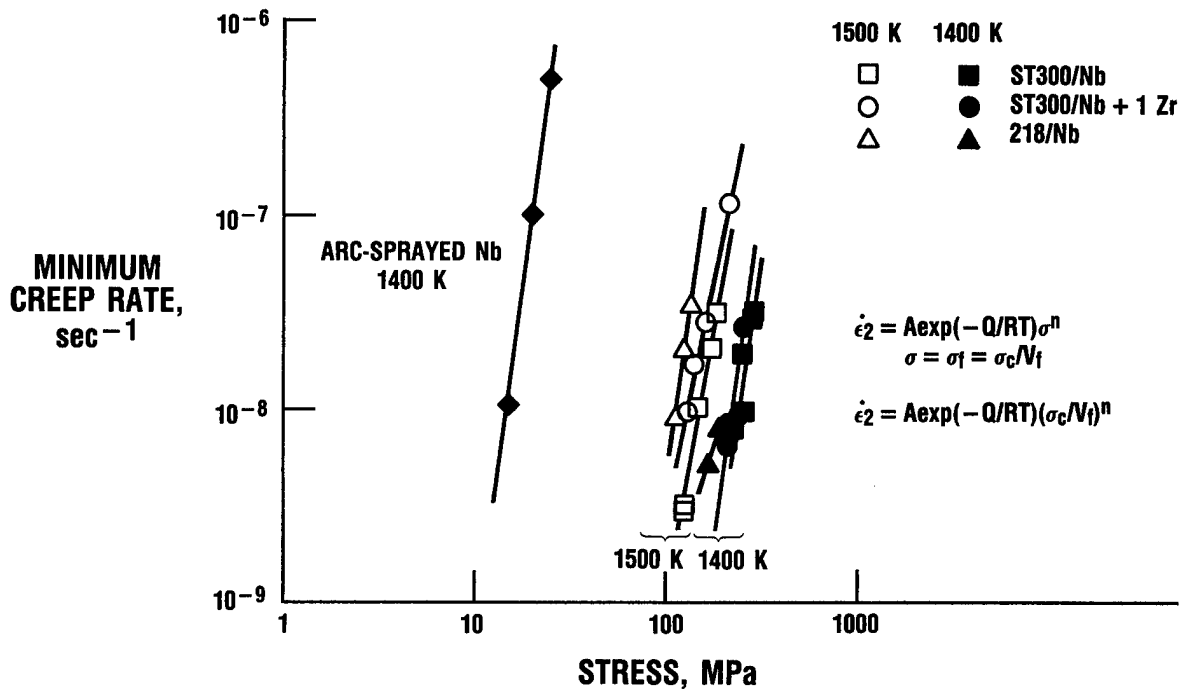

FIGURE 24. - COMPARISON OF MINIMUM CREEP RATE FOR COMPOSITES.

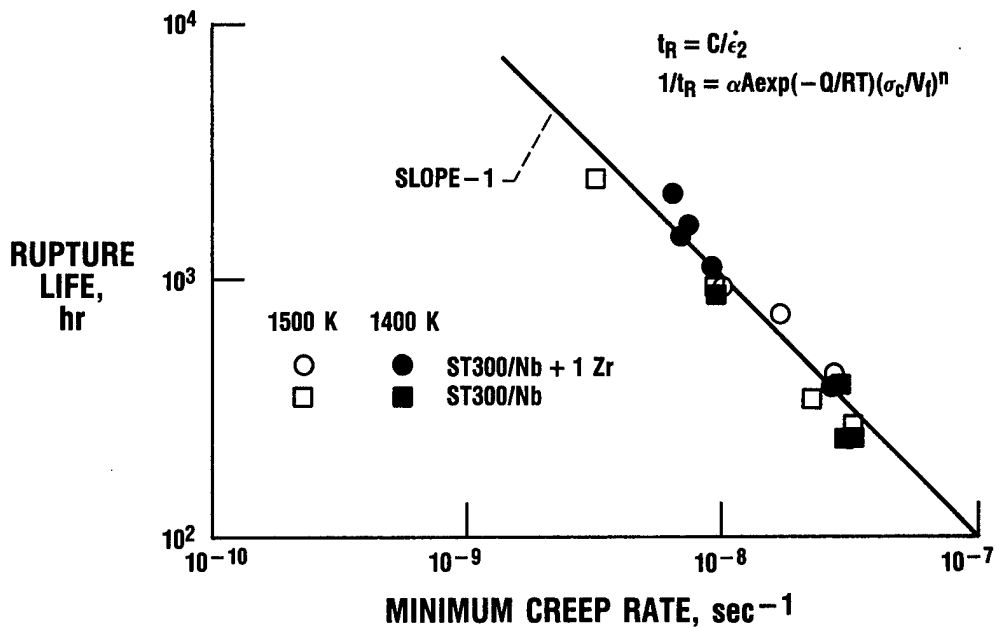

FIGURE 25. - RELATIONSHIP BETWEEN RUPTURE LIFE AND MINIMUM CREEP RATE FOR COMPOSITES.

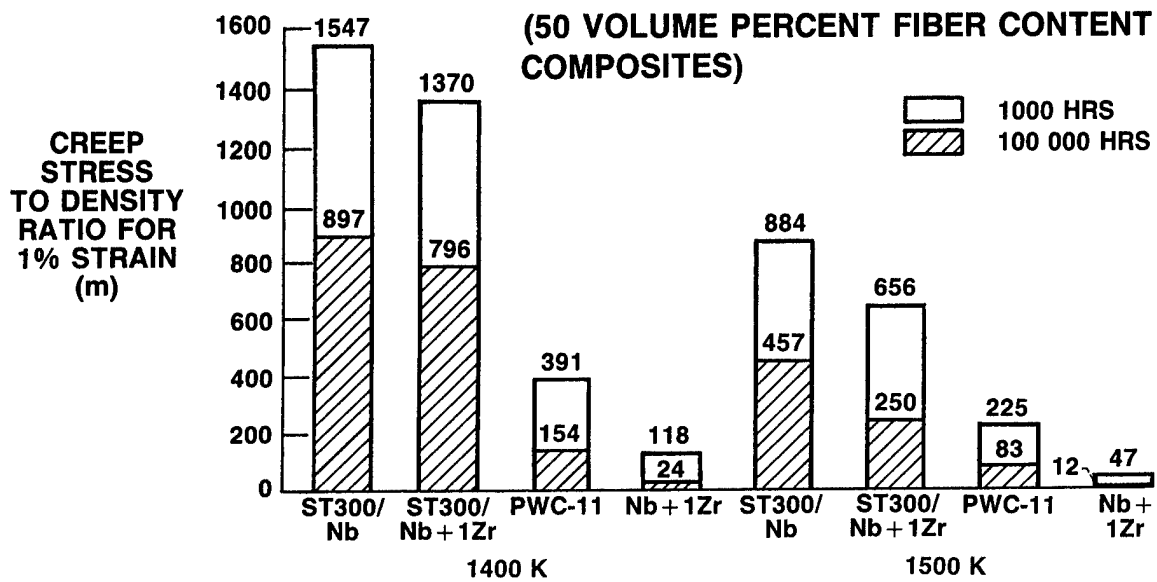

FIGURE 26. - COMPARISON OF PROJECTED 1000 AND 100 000 HOUR CREEP STRESS TO DENSITY RATIO FOR 1 PERCENT STRAIN.

1. Report No. NASA TM-100946		2. Government Accession No.		3. Recipient's Catalog No.	
4. Title and Subtitle Refractory Metal Alloys and Composites for Space Power Systems				5. Report Date	
				6. Performing Organization Code	
7. Author(s) Joseph R. Stephens, Donald W. Petrasek, and Robert H. Titran				8. Performing Organization Report No. E-4237	
				10. Work Unit No. 586-01-11	
9. Performing Organization Name and Address National Aeronautics and Space Administration Lewis Research Center Cleveland, Ohio 44135-3191				11. Contract or Grant No.	
				13. Type of Report and Period Covered Technical Memorandum	
12. Sponsoring Agency Name and Address National Aeronautics and Space Administration Washington, D.C. 20546-0001				14. Sponsoring Agency Code	
15. Supplementary Notes Prepared for the Spring Meeting of the Materials Research Society, Reno, Nevada, April 4-9, 1988.					
16. Abstract Space power requirements for future NASA and other United States missions will range from a few kilowatts to megawatts of electricity. Maximum efficiency is a key goal of any power system in order to minimize weight and size so that the space shuttle may be used a minimum number of times to put the power supply into orbit. Nuclear power has been identified as the primary power source to meet these high levels of electrical demand. One method to achieve maximum efficiency is to operate the power supply, energy conversion system, and related components at relatively high temperatures. NASA Lewis Research Center has undertaken a research program on advanced technology of refractory metal alloys and composites that will provide base line information for space power systems in the 1900's and the 21st century. Basic research on the tensile and creep properties of fibers, matrices, and composites will be discussed.					
17. Key Words (Suggested by Author(s)) Refractory metals; Composites; Space power; Creep; Stress-rupture; Fabrication			18. Distribution Statement Unclassified - Unlimited Subject Category 26		
19. Security Classif. (of this report) Unclassified		20. Security Classif. (of this page) Unclassified		21. No of pages 32	22. Price* A03

National Aeronautics and
Space Administration

Lewis Research Center
Cleveland, Ohio 44135

Official Business
Penalty for Private Use \$300

FOURTH CLASS MAIL

ADDRESS CORRECTION REQUESTED



Postage and Fees Paid
National Aeronautics and
Space Administration
NASA 451

Institute for Defense Analyses
1801 N. Beauregard Street
Alexandria, VA 22311
Attn: M. A. Rigdon (1)

NASA
