

JUL 29 2004

REPORT DOCUMENTATION PAGE			Form Approved OMB No. 0704-0188	
Public reporting burden for this collection of information is estimated to average 1 hour per response, including the time for reviewing instructions, searching existing data sources, gathering and maintaining the data needed, and completing and reviewing the collection of information. Send comments regarding this burden estimate or any other aspect of this collection of information, including suggestions for reducing this burden, to Washington Headquarters Services, Directorate for Information Operations and Reports, 1215 Jefferson Davis Highway, Suite 1204, Arlington, VA 22202-4302, and to the Office of Management and Budget, Paperwork Reduction Project (0704-0188), Washington, DC 20503.				
1. AGENCY USE ONLY (Leave blank)	2. REPORT DATE 28.Jul.04	3. REPORT TYPE AND DATES COVERED DISSERTATION		
4. TITLE AND SUBTITLE UTILIZING ROUTINE WATER QUALITY INSTRUMENTS FOR MONITORING DISTRIBUTION SYSTEM SECURITY			5. FUNDING NUMBERS	
6. AUTHOR(S) MAJ BYER DAVID E				
7. PERFORMING ORGANIZATION NAME(S) AND ADDRESS(ES) COLORADO STATE UNIVERSITY			8. PERFORMING ORGANIZATION REPORT NUMBER  CI04-531	
9. SPONSORING/MONITORING AGENCY NAME(S) AND ADDRESS(ES) THE DEPARTMENT OF THE AIR FORCE AFIT/CIA, BLDG 125 2950 P STREET WPAFB OH 45433			10. SPONSORING/MONITORING AGENCY REPORT NUMBER	
11. SUPPLEMENTARY NOTES				
12a. DISTRIBUTION AVAILABILITY STATEMENT Unlimited distribution In Accordance With AFI 35-205/AFIT Sup 1		12b. DISTRIBUTION CODE <b>DISTRIBUTION STATEMENT A</b> Approved for Public Release Distribution Unlimited		
13. ABSTRACT (Maximum 200 words)				
14. SUBJECT TERMS			15. NUMBER OF PAGES 181	
			16. PRICE CODE	
17. SECURITY CLASSIFICATION OF REPORT	18. SECURITY CLASSIFICATION OF THIS PAGE	19. SECURITY CLASSIFICATION OF ABSTRACT	20. LIMITATION OF ABSTRACT	

20040809 007

**DISSERTATION**

**UTILIZING ROUTINE WATER QUALITY INSTRUMENTS FOR  
MONITORING DISTRIBUTION SYSTEM SECURITY**

Submitted by

David E. Byer

Department of Civil Engineering

In partial fulfillment of the requirements

for the Degree of Doctor of Philosophy

Colorado State University

Fort Collins, Colorado

Summer 2004

**DISTRIBUTION STATEMENT A**  
Approved for Public Release  
Distribution Unlimited

## **ABSTRACT OF DISSERTATION**

### **UTILIZING ROUTINE WATER QUALITY INSTRUMENTS FOR MONITORING DISTRIBUTION SYSTEM SECURITY**

Drinking water system security concerns have been a considerable issue in the United States in recent years, but in the last two years this issue has risen to new levels of urgency. The tragic events of September 11th highlighted America's vulnerability to terrorism and spurred a domestic security response unprecedented since World War II. Currently, significant purposeful contamination of a water system won't be properly characterized until post-symptomatic epidemiological events are manifested in the affected community. One approach to mitigating this potential disaster includes on-line monitoring of drinking water distribution systems. Four credible threat chemical drinking water contaminants (aldicarb, sodium arsenate, sodium cyanide, and sodium fluoroacetate) were analyzed at different concentrations to determine their detectability in a drinking water distribution system using commonly measured parameters. On-line monitoring that measured conductivity, pH, chlorine residual, turbidity, and total organic carbon was completed to determine baseline water quality indicators. The contaminants were then mixed with tap water and analyzed in beakers to determine their contaminant-instrument response at various concentrations with bench top instruments. This data was then used to determine dosing into a bench scale distribution system. The contaminants were then added at the specified concentrations to determine detectability using the on-line monitoring equipment. Results indicate that the four chemical contaminants can be detected at relatively low concentrations with routine monitoring. Three of the four

chemical contaminants can be detected below a concentration that will cause significant health impacts. When these same contaminants were introduced into an acclimated bioreactor, it was determined that toxicity induced sloughing off of biomass increased the turbidity response significantly, effectively lowering the limit of detection for the chemical contaminants. To ensure that the increase in turbidity was a result of toxicity induced sloughing off of biomass, cell counts were conducted on the biofilm containing PVC coupons using fluorescence microscopy. It was shown that indeed cell counts were significantly reduced after introduction of the contaminants. Multivariate cluster analysis of the data also demonstrated a potential to reduce the time to detect a contamination event versus univariate analysis.

David E. Byer  
Civil Engineering Department  
Colorado State University  
Fort Collins, CO 80523  
Summer 2004

## ACKNOWLEDGEMENTS

I am indebted to several people and organizations that allowed completion of this effort. First and foremost to my adviser, Dr. Ken Carlson, whose guidance and commitment to me and this effort was exceptional. Sincere appreciation is extended to my graduate committee who offered considerable advice and assistance along the way. To the Air Force Institute of Technology for providing me the opportunity to pursue this program, and who provided full funding. To Dr. Donald Klein and Tamara Heskett from CSU's Microbiology department who worked diligently with me on the biofilm portion of this work. To John Frazey, another graduate student, who was a tremendous help collecting the distribution system contaminant-instrument response data. To Mary Casey who helped me on a daily basis with University administrative requirements, and who I'm sure the ERC could not operate effectively without. To Gloria Garza who compiled the tables in Appendix A. To Kevin Gertig of Fort Collins Utilities who shared his time and expertise, and ensured that this effort was well founded and practical. And finally to the Hach Company and Karl King, who provided the on-line monitoring instrumentation that was essential to the data collection effort.

## DEDICATION

To my wife [REDACTED],

and our three sons, [REDACTED], [REDACTED], and [REDACTED]

# TABLE OF CONTENTS

ABSTRACT OF DISSERTATION.....	iii
ACKNOWLEDGEMENTS.....	v
DEDICATION.....	vi
TABLE OF CONTENTS.....	vii
LIST OF TABLES.....	ix
LIST OF FIGURES.....	x
LIST OF ABBREVIATIONS.....	xii
CHAPTER 1 INTRODUCTION.....	1
1.1 Background.....	1
1.2 Purpose Of Study.....	3
1.3 Limitations Of Study.....	3
1.4 Dissertation Structure.....	5
CHAPTER 2 LITERATURE REVIEW.....	7
2.1 The Need For This Study.....	8
2.2 Desired Properties Of An Early Warning System.....	10
2.3 Credible Threat Contaminants.....	12
2.4 Contaminant Specific Versus Water Quality Surrogate Monitors.....	18
2.5 Candidate Instruments And Observables.....	20
2.6 Drinking Water Distribution System Parameters.....	22
2.7 Sample Collection For Further Analysis And Evidence.....	26
2.8 Public Health Indicators.....	27
2.9 Equipment Maintenance Considerations.....	28
2.10 Microbiological Simulation Of The Distribution System.....	29
2.11 Data Collection/Formatting Guidance.....	34
2.12 Management Issues Associated With Data Analysis.....	37
2.13 Setting Alarm Triggers.....	39
2.14 Cluster Analysis.....	41
2.15 Summary.....	42
2.16 Hypotheses.....	46
CHAPTER 3 UNDERSTANDING VARIATION IN BASELINE DRINKING WATER QUALITY.....	47
3.1 Introduction.....	47
3.2 Objectives.....	47
3.3 Bench Scale Distribution System Setup And Operation.....	48
3.4 Materials and Methods.....	53
3.5 Challenges.....	55
3.6 Results/Discussion.....	55
3.7 Summary.....	57
CHAPTER 4 CONTAMINANT-INSTRUMENT RESPONSE.....	59
4.1 Introduction.....	59
4.2 Methods and Materials.....	62
4.3 Results and Discussion.....	67

4.4	Conclusions.....	86
CHAPTER 5 CLUSTER ANALYSIS.....		89
5.1	Introduction.....	89
5.2	Materials and Methods.....	92
5.3	Results/Discussion.....	95
5.4	Conclusions.....	109
CHAPTER 6 SECONDARY INSTRUMENT RESPONSE FROM BIOFILMS .....		111
6.1	Introduction.....	111
6.2	Materials and Methods.....	114
6.3	Results and Discussion .....	118
6.4	Conclusions.....	126
CHAPTER 7 CONCLUSIONS AND RECOMMENDATIONS.....		127
REFERENCES .....		132
APPENDIX A	INSTRUMENTS AND TEST KITS .....	139
APPENDIX B	DISTRIBUTION SYSTEM DATA.....	149
APPENDIX C	BEAKER TEST DATA.....	156
APPENDIX D	BIOREACTOR AND BIOFILM DATA AND PICTURES .....	158
APPENDIX E	CLUSTER ANALYSIS .....	178

## LIST OF TABLES

Table 2-1	Relative factor of effectiveness of selected contaminants.....	13
Table 2-2	Potential water quality surrogates per class of contaminant .....	20
Table 2-3	Summary of SCADA system considerations .....	37
Table 2-4	Summary of management issues associated with data analysis .....	38
Table 3-1	Pipe size use in Fort Collins distribution system .....	50
Table 3-2	Analytical instruments used in this study .....	53
Table 3-3	On-line instrument accuracy.....	54
Table 3-4	On-line monitoring baseline water quality results.....	56
Table 4-1	On-line monitoring baseline water quality results.....	71
Table 4-2	Percentage of baseline data points falling within $\bar{x} \pm 3\sigma$ .....	74
Table 4-3	Properties of interest for credible threat chemical contaminants .....	77
Table 4-4	Limits of detection for contaminants per water quality surrogate.....	82
Table 5-1	Limits of detection for contaminants per water quality surrogate without consideration of equipment accuracy.....	101
Table 5-2	Comparison of peak minus baseline average instrument response for most and least sensitive contaminant to cluster analysis.....	106
Table 5-3	Comparison of detection times for univariate versus multivariate analysis..	108
Table 6-1	Cell counts .....	115
Table 6-2	Changes in turbidity, cell counts, and log removal of cells after exposure to contaminant.....	122
Table 6-3	Limits of detection from previous work compared to biofilm detectability .	125
Table A-1	Summary of commercially available instruments and testing kits. ....	140
Table A-2	Summary of experimental-stage instruments. ....	147
Table B-1	Example of on-line data as collected. ....	150
Table C-1	Beaker test experimental results .....	157
Table D-1	Cell count data from eight coupons to determine homogeneity.....	164
Table D-2	Summary of cell counts per coupon from Table D-1 with descriptive statistics .....	166
Table D-3	Bioreactor turbidity results .....	167
Table D-4	Cell counts for biofilm exposed to 15 mg/L of sodium arsenate.....	168
Table D-5	Cell counts for biofilm exposed to 5 mg/L of sodium arsenate.....	169
Table D-6	Cell counts for biofilm exposed to 1 mg/L of sodium fluoroacetate (1080)	170
Table D-7	Cell counts for biofilm exposed to 0.5 mg/L of sodium fluoroacetate (1080) .....	171
Table D-8	Cell counts for biofilm exposed to 0.5 mg/L of aldicarb.....	172
Table D-9	Cell counts for biofilm exposed to 0.25 mg/L of aldicarb.....	173
Table D-10	Cell counts for biofilm exposed to 0.5 mg/L of sodium cyanide .....	174
Table D-11	Cell counts for biofilm exposed to 0.25 mg/L of sodium cyanide .....	175
Table D-12	Summary of live cell counts for biofilm per exposure .....	176
Table D-13	Summary of log removal of cells per exposure .....	177
Table E-1	Cluster averages per contaminant and concentration.....	179

## LIST OF FIGURES

Figure 2-1 Iron triangle for contaminant detection in distribution systems.....	11
Figure 2-2 Biofilm formation.....	31
Figure 2-3 SCADA system with typical components (AWWARF, 2002).....	35
Figure 3-1 Bench scale distribution system schematic.....	49
Figure 4-1 Bench scale distribution system photo.....	63
Figure 4-2 Baseline water quality time series plots.....	72
Figure 4-3 Concentration-instrument response for sodium fluoroacetate (1080),chlorine residual, and TOC.....	78
Figure 4-4 Concentration-instrument response for sodium cyanide, pH, and TOC.....	80
Figure 4-5 Concentration-instrument response for sodium arsenate and conductivity ..	81
Figure 4-6 Time series plot of on-line instrument response for sodium arsenate and conductivity.....	84
Figure 4-7 Time series plot of on-line instrument response for sodium cyanide and pH	85
Figure 4-8 Time series plot of on-line instrument response for aldicarb and chlorine residual.....	85
Figure 4-9 Time series plot of on-line instrument response for aldicarb and TOC.....	86
Figure 5-1 Example of k-means clustering by iteration (Hastie et. al, 2001).....	91
Figure 5-2 Raw instrument-response data before clustering.....	93
Figure 5-3 Data from Figure 5-2 assigned to clusters.....	94
Figure 5-4 Bivariate plot of instrument response after 3 mg/L of sodium fluoroacetate was added to tap water.....	97
Figure 5-5 Bivariate plot of instrument response after 1 mg/L of aldicarb was added to tap water.....	98
Figure 5-6 Bivariate plot of instrument response after 15 mg/L of sodium arsenate was added to tap water.....	99
Figure 5-7 Bivariate plot of instrument response after 1 mg/L of sodium cyanide was added to tap water.....	100
Figure 5-8 Instrument response and cluster assignment after 3 mg/L of sodium fluoroacetate was added to tap water.....	103
Figure 5-9 Instrument response and cluster assignment after 3 mg/L of aldicarb was added to tap water.....	104
Figure 5-10 Instrument response and cluster assignment after 25 mg/L of sodium arsenate was added to tap water.....	105
Figure 5-11 Instrument response and cluster assignment after 1 mg/L of sodium cyanide was added to tap water.....	106
Figure 6-1 Fluorescing of live and dead cells under UV light.....	118
Figure 6-2 Turbidity response from biofilm exposure to contaminants.....	119
Figure 6-3 Toxicity induced cell death per contaminant concentration.....	120
Figure B-1 Histogram of laser turbidity with normal curve.....	152
Figure B-2 Histogram of TOC with Normal Curve.....	152
Figure B-3 Histogram of Chlorine Residual with Normal Curve.....	153
Figure B-4 Histogram of Turbidity with Normal Curve.....	153
Figure B-5 Histogram of Conductivity with Normal Curve.....	154
Figure B-6 Histogram of pH with Normal Curve.....	154

Figure B-7 Comparison of instrument response, $3\sigma$ , and equipment accuracy.....	155
Figure D-1 Top view of open bioreactor .....	159
Figure D-2 PVC coupon .....	160
Figure D-3 Uncovered bioreactors and heat exchanger setup .....	160
Figure D-4 Covered bioreactors and heat exchanger setup .....	161
Figure D-5 Coupon scraper.....	161
Figure D-6 Test tube apparatus used for cell counts.....	162
Figure D-7 Retention tubes and fluorescent dies used in cell counts .....	163

## LIST OF ABBREVIATIONS

<b>ATP</b>	Adenosine Triphosphate
<b>AWWA</b>	American Water Works Association
<b>CDC</b>	Centers for Disease Control and Prevention
<b>EPS</b>	Extracellular Polymer Substances
<b>ERC</b>	Engineering Research Center
<b>JAWWA</b>	Journal of the American Water Works Association
<b>LD<sub>50</sub></b>	Lethal Dose at which 50% of exposed population will perish
<b>mg/L</b>	milligrams per liter
<b>nm</b>	nanometer
<b>NTU</b>	Nephelometric Turbidity Unit
<b>ORP</b>	Oxidation Reduction Potential
<b>PCR</b>	Polymerase Chain Reaction
<b>psi</b>	Pounds per Square Inch
<b>PVC</b>	Poly Vinyl Chloride
<b>RAB</b>	Rotating Annular Bioreactor
<b>RAPID</b>	Ruggedized Advanced Pathogen Identification Device
<b>RPM</b>	Revolutions Per Minute
<b>SCADA</b>	Supervisory Control and Data Acquisition
<b>TOC</b>	Total Organic Carbon
<b>μS/cm</b>	Micro Siemens per Centimeter
<b>USEPA</b>	United States Environmental Protection Agency

## CHAPTER 1 INTRODUCTION

### 1.1 *Background*

United States drinking water systems are amongst the greatest engineering and public health accomplishments of the 20th century (National Academy of Engineering 2000, Centers for Disease Control and Prevention 1999). President Clinton signed Executive Order 13010 in 1996 designating water supply systems as one of eight critical infrastructures, "so vital that their incapacity or destruction would have a debilitating impact on the defense or economic security of the United States" (Federal Register, 1996). Concerns over the security of drinking water distribution systems date back to approximately 300 B.C. during the construction of *Aqua Appia*, one of the aqueducts of the Roman Empire. The Romans were concerned that their water supply systems would be rendered useless by enemy action. To avert this threat, some of their aqueducts were buried up to 50 feet in the ground (Herschel, 1973).

Likewise, in the United States, distribution system security is not a new concern. In the words of J. Edgar Hoover, the Director of the FBI at the onset of World War II, "It has long been recognized that among public utilities, water supply facilities offer a particularly vulnerable point of attack to the foreign agent, due to the strategic position they occupy in keeping the wheels of industry turning and in preserving the health and morale of the American people. In order that America may meet the challenge to world democracy, all of her vast resources must be brought into play and coordinated into a productive, well-balanced defense program never before realized in the history of this country. In this great undertaking, water supply facilities occupy a key position, and, therefore, it is essential that they operate without interruption" (Hoover, 1941).

What is new is the increased awareness and concern due to the tragic events of September 11, 2001. Drinking water systems were identified almost immediately as a potential target for further attacks and were urged by the FBI to implement security measures (Rose, 2002).

Currently, significant purposeful contamination of a water system won't be properly characterized until post-symptomatic epidemiological events are manifested in the affected community (Khan et al., 2000). Most drinking water systems currently monitor a significant number of water quality parameters at the plant. These are required for compliance and maintenance of water quality as the water enters the distribution system. In the distribution system, water quality is usually monitored through grab samples with an analysis turn-around time of hours to days. Unfortunately, these grab samples are not analyzed for unique or exotic contaminants that may be used by terrorists (National Research Council, 2002).

Eighty percent of the US population is served by 14% of the utilities (Clark et al., 2002). This highlights the impact that an act of sabotage to a large drinking water system may have. Water distribution networks have been identified as a major vulnerability. The distribution system is uniquely vulnerable because of its accessibility to those it serves, and the geographic area that it reaches. Long term actions that a utility should consider taking include the use of early warning monitoring systems in the distribution systems that will detect changes in chemical characteristics of the water (DeNileon 2001, Clark and Deininger 2000).

This effort developed a novel method for detecting significant distribution system contamination events in real-time using commonly available monitoring equipment.

The significance of this ability is timely response and mitigation to expedite the return of the water system back to service, and to inform the public health agencies expeditiously to help in disease diagnosis if remedial action isn't taken quickly enough. This capability is also applicable to daily water quality monitoring. Results of this research could be used in the detection of common contamination events such as backflow, line breaks, iron from heavily tuberculated cast-iron mains, and sloughed-off biofilm, to name a few.

### **1.2 Purpose Of Study**

The primary objective of this research was to develop a methodology for the real-time detection of significant chemical disturbances in a drinking water distribution system. In particular, the research was aimed at detecting intentional contamination events. The primary objective was accomplished by combining routine monitoring instruments that are readily available and relatively inexpensive with advanced data analysis techniques. The research provides needed information to interpret real-time distribution system monitoring that has begun or will be implemented in the future.

### **1.3 Limitations Of Study**

This research was conducted within a fixed budget and schedule over a period of approximately three academic years. During this time, conception of the idea and approach, acquisition of the on-line monitoring equipment, construction of the bench-scale distribution system, growth and analysis of steady-state biofilms, multiple experiments with and without hazardous materials, inclusion of the data to develop data analysis models, and writing of this dissertation have all occurred.

Limitations of this study include a relatively short list of chemical contaminants. Within that short list, radioactive materials, military agents, and biotoxins are not

included. Additional limitations include the number of concentrations per contaminant that the experiments are run at, and the use of young biofilms in the study.

Extensive literature review and consultation with DoD and industry personnel quickly brought four contaminants (two organic, two inorganic) to the top of the list. Omitted from that list are radiological contaminants, military agents, and biotoxins. In one government document, radiological contaminants are discussed, then summarized as not posing a significant contamination threat to drinking water (Confidential US government report). Factors include the large amount of radioactivity required to cause fatalities, the small quantities of material available, the controlled nature of the material, the difficulties in handling of the material, and challenges with dispersing it in drinking water. In a U.S. Army Center for Environmental Health Research document, radiological agents are classified as an unlikely military drinking water health threat (Reuter, 2002). Other documents dismiss radiological contaminants outright by not including them in major threat lists (Tiemann, 2002).

Military agents are closely monitored by the international community. One chemical agent that has risen near the top of many lists includes the nerve agent VX. VX is a very tightly controlled substance. Its use, possession, and manufacture are banned by the international Chemical Weapons Convention (<http://www.opcw.org/>). It would not be realistic to assume that CSU could acquire VX for this research effort. Likewise, biotoxins are extremely toxic, not readily available, and would require special ventilation hoods and controls to work with safely that are not available at the Engineering Research Center.

This research effort is focused on using advanced data analysis techniques to determine the *minimal* concentration at which a contamination event, based on changes in water quality parameters, can be detected. It is unnecessary to conduct experiments using concentrations of contaminants outside of the range of minimal detection.

The advanced data analysis technique applied to the experimental data was k-means clustering. There are several other potential clustering or classification techniques available. In addition, some of these techniques encourage inputting data that has been pre-processed. Types of pre-processing that may be used include scaling the different data sets to ensure that they are all of a similar magnitude, and normalizing the raw data. The data that was used in the k-means algorithm was not pre-processed, and this may have impacted the results.

It has been established that 4-6 weeks is a reasonable time in which to grow a steady-state biofilm in a rotating annular reactor (Camper 1995, Butterfield et al. 2002). Ollos et al. (2003) posed an intriguing question inquiring about the differences in a 4-6 week old or less steady-state biofilm and a more established biofilm grown on a 40-year old tuberculated cast iron pipe. Unfortunately, this question is outside the scope of this research effort.

#### **1.4 Dissertation Structure**

Chapters 1 and 2 include the introduction and literature review. Chapter 3 provides a background on the significance of baseline information in water quality studies in the distribution system, data that was obtained to demonstrate some properties of baseline distribution system water quality, and also explains the setup and operation of the bench scale distribution system and bioreactor used in the data collection effort.

Chapters 4-6 are the main focus of the dissertation. Each of these chapters is written as a stand-alone paper with its own introduction, material and methods, and results/discussion sections. Conclusions and recommendations are provided in Chapter 7.

## CHAPTER 2 LITERATURE REVIEW

There are several different approaches being considered to increase distribution system security by the drinking water industry. Examples include increased physical security, redundancy of low density but critical equipment (e.g. pumps), and on-line monitoring. On-line monitoring approaches include contaminant-specific detection technology, microsensor technology, and the utilization of surrogate water quality indicators to detect non-specific contamination events. This research effort adds two very unique approaches utilizing water quality indicators to detect non-specific contamination events: microbiological simulation of the distribution system using rotating annular reactors, and the use of advanced data analysis techniques to reduce the limit of detection of a contamination event.

Following is a review of literature that is specific to significant components of this research effort. These components include demonstrating a valid need for this research, establishing a credible threat contaminant list to be used in the research, the use of rotating annular bioreactors to simulate microbiological conditions in a distribution system, and applying data analysis tools in anomaly detection. In addition, additional topics will be presented in the literature review that are of significant importance in distribution system security monitoring, namely: desired properties of an early warning system, contaminant specific versus water quality surrogate monitoring, candidate instruments and observables, sample collection for further analysis and evidence, public health indicators, monitoring equipment maintenance considerations, and identifying

suitable distribution system water quality parameters that could be used to determine if a contamination event has taken place.

## **2.1 The Need For This Study**

The Public Health Security and Bioterrorism Preparedness and Response Act of 2002 (National Archives and Records Administration, 2002) directs the EPA to review methods to detect threats to drinking water safety. The President's Commission on Critical Infrastructure Protection concluded that water supplies have inadequate protection against the threat of chemical and biological contamination, and that technology is lacking to allow detection of contaminants in water (Tiemann, 2002).

Khan et al. (2001) highlight the fact that except in the case of aerosols, food or water contamination is the easiest way to distribute chemical and biological agents. Due to the population that a drinking water distribution system serves, a large number of casualties would occur over a wide geographic area. This is particularly alarming when three weeks pass before a source of contamination is identified, as was displayed during the cryptosporidiosis outbreak in Milwaukee during 1993. This incident in and of itself demonstrated the potential for drinking water to serve as a conveyance for the spread of disease -- the largest documented waterborne disease outbreak in the USA since 1920 when record-keeping began.

Drinking water systems must be prepared to prevent illness and injury that would result from biological and chemical terrorism. According to Khan et al. (2000), in the use of biological agents, the first casualties will be identified by physicians or other health care providers due to the onset of symptoms well after exposure (latency period). The point needs to be made that animals, as well as humans will suffer in these types of

events, and there are a lot of lessons to be learned from observing suspicious health problems in our animals. Early detection of a chemical or biological contamination event is crucial. The use of new agents, combinations of agents, or contaminants that haven't been seriously considered is a very plausible terrorist approach. Because of this, the use of surrogates for detection, to cast a broader net, is emphasized. Early detection is absolutely essential.

Rose (2002) found that water specialists and scientists believe that the nation's water supply is vulnerable. Contamination of drinking water distribution systems is amongst the greatest threat. The need has been identified in several reports in 2001 and 2002 to conduct research and develop monitoring technologies that will address water quality concerns that can be included in a risk assessment framework. Funds are needed to develop new and sophisticated monitoring tools.

The National Research Council (2002) recommended that the USEPA determine the persistence of pathogens, chemical contaminants, and other contaminants in drinking water systems that maintain a chlorine residual. They further recognized that forced entry of a highly toxic contaminant into the distribution system could have serious consequences. The National Research Council recommended that the National Institute of Standards and Technology and industry associations should examine the possibility of sensor systems that would protect the water supply. They further declared that monitoring and identification of biological and chemical agents is amongst the four highest-priority areas for research on water security. Sensors should be utilized that will continuously monitor the water. These sensors would also be ideal to detect backflow events.

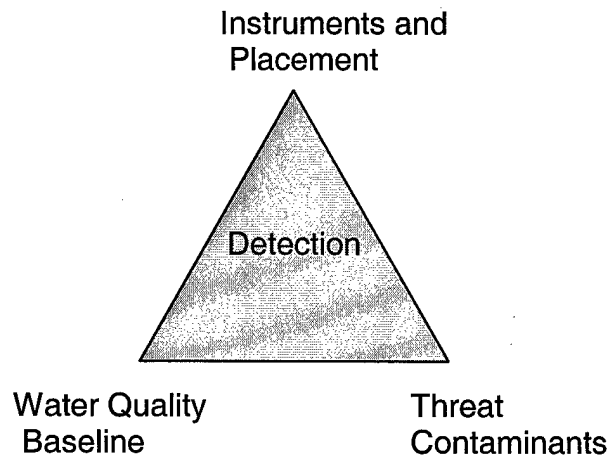
Luthy (2002) emphasized the importance of protecting water quality by expediting the detection of contaminants to minimize impacts to human health. The use of multiple barriers in the distribution system, versus just a residual oxidant, was identified as a valid requirement. On-line detection may be considered an additional barrier in the distribution system.

The development and use of real-time monitoring was recommended by Parmlee (2002) and States et al. (2003) to protect against bioterrorism in water systems. This recommendation was validated when the USEPA awarded a \$500,000 project to the USGS to set up real-time monitoring equipment at two drinking water systems in New Jersey (USEPA, 2002). The significance of this effort is best captured in the USEPA's quote at the onset of the project, "Whether a contaminant enters a water supply system by terrorist action or by accident, it is vital that we have the information to respond quickly. That's why real-time monitoring offers such great promise." In addition, it was emphasized that real-time monitoring will allow water system operators to be aware of potentially dangerous situations before contaminated water reaches consumer taps. Finally, Deininger et al. (2000) summarize it best, "Strategically placed monitors in a distribution system is the obvious solution for the protection of a water supply system."

## **2.2 *Desired Properties Of An Early Warning System***

Unfortunately, a continuous monitoring "silver bullet" does not exist. It will likely take a suite of instruments and monitors to provide early warning in the instance of a contamination event. Whatever the platform(s), one goal would be to detect as many contaminants as possible at a concentration that will allow response before consumers become ill, paying particular attention to ensure that all contaminant classes are covered

(chemical, microbiological, toxin, and radiological). Figure 2-1 below depicts an iron triangle for detection, emphasizing the importance of knowing which threat contaminants should be monitored for, selection and placement of the appropriate monitoring equipment to detect those contaminants, and an appreciation of baseline water quality conditions specific to the distribution system that is being monitored.



**Figure 2-1** Iron triangle for contaminant detection in distribution systems

While trying to detect threat contaminants, false positives and negatives need to be minimized. False negatives would let contaminants through the system undetected, while false positives would soon discredit the monitor, and would likely result in it being removed from service. One approach for reducing false positive and negative readings would be to use instruments at multiple locations, anticipating a response downstream supportive of an upstream response. When results are obtained, they would need to be quantifiable and reproducible. The results need to be obtained fast enough, and at concentrations low enough, to allow an appropriate response. Where required,

infrastructure would have to be in place to ensure that monitoring could be achieved during all seasons, and monitoring results could be transmitted from remote locations. Finally, the technology used should require minimal skill and training to perform the tests, and of course, be affordable.

Summarizing, desired properties of a distribution early warning system include

- Ability to detect as many contaminants as possible per contaminant class
  - Chemical
  - Microbiological
  - Toxin
  - Radiological
- Capability to detect these contaminants below health threat levels (e.g. LD<sub>50</sub>)
- Minimize false positives and negatives
- Produce quantifiable and reproducible results
- Compatible with infrastructure that is in place (e.g. SCADA, sanitary, power)
- Availability of remote monitoring
- Can withstand all seasons/climates/conditions
- Alarm triggered auto-sampling for further analysis and evidence

### **2.3 Credible Threat Contaminants**

Teter (2002) states that the intentional contamination of a large (1,000 MGD) public water system with chemical and biological agents is a credible threat. As a barrier to this threat, chlorination is highly favored over chloramination as a disinfectant in the distribution system. Teter uses a ranking system to determine the most credible threat contaminants. This system consists of the following categories: health effects of the

agent, latency period between exposure and display of symptoms, the agent's persistence in the water supply, the ease of disseminating an agent, the ease of obtaining an agent, and the threat to the saboteur. Using this system, *Bacillus anthracis* was ranked as the most credible threat, with *Cryptosporidium parvum* as the fourth most credible threat.

Like Teter, other authors have defined properties of contaminants that make them more attractive to a saboteur. Deininger et al. (2000) identify high toxicity, high water solubility, chemical and physical stability, a lack of taste, color and odor, and a low chance of detection with normal analytical methods as being key properties of credible threat contaminants. To emphasize the importance of solubility and toxicity, Deininger defines a Relative Factor of Effectiveness for the contaminant,

$$R = \frac{\text{solubility (mg/L)}}{\text{lethal dose x 1000 (mg/human)}}$$

For contaminants of interest in this study, Deininger provides the following R factors in table 2-1 below:

**Table 2-1** Relative factor of effectiveness of selected contaminants

Contaminant	Relative Factor of Effectiveness, R
Cyanide	9
Sodium Fluoroacetate	1
Arsenate	1

Reuter (2002) specifies toxicity or infectivity, solubility, effect of disinfection, and taste and odor at or below health effect concentrations as key to prioritizing threat agents. In addition, maintaining a chlorine residual is listed as lowering the health threat of many potential microbiological contaminants, except spores and cysts. To demonstrate the ineffectiveness of chlorine on inactivation of oocysts, Khan et al. (2001) state that it takes 720 mg/L of chlorine with a contact time of 10-minutes to kill *Cryptosporidium parvum* oocysts.

In addition, Allmann (2003) considered methodologies of injecting credible threat chemical contaminants into the distribution system with the use of a hydraulic model. He found that variations in the injection method and the ability to detect a contamination event made a considerable difference in the effectiveness of a waterborne attack. He found contamination moved uniformly throughout the distribution system, termed as "sheet flow," and that this sheet flow was of great concern because it allowed contaminant flow through neighborhoods to enter larger distribution system lines, furthering the spread of very toxic contaminants.

According to Burrows and Renner (1999), microbiological contaminants are recognized as significant potential waterborne threats. In addition, they state that the dose required to cause adverse health effects would require the injection point to be post-treatment. Most of these potential contaminants are readily available from within the United States, or can be obtained easily elsewhere.

For chemical contaminants, Khan et al. (2000) use the following criteria to prioritize contaminant credibility: already known to be weaponized, available to potential terrorists, likely to cause major morbidity or mortality, potential of causing

public panic and social disruption, and requires special action for public health preparedness. They list the following as priority chemical agents: arsenic, pesticides, and cyanides. The National Research Council (2002) addresses morbidity and mortality, or toxicity, by focusing on cholinesterase inhibitors, including insecticides (e.g. aldicarb), that act like nerve agents, and are persistent in water. These particular contaminants could arrive in high enough concentration to be harmful to consumers, with the only barrier being the disinfectant residual. The US Army Center for Health Promotion and Preventive Medicine listed sodium cyanide and fluoroacetate as priority potential chemical threat agents (Burrows et al., 1997).

Contaminants that were used in this research include sodium cyanide, sodium fluoroacetate, aldicarb, and sodium arsenate. All are considered very credible water threat contaminants.

Cyanide has been used for thousands of years as a deadly poison to contaminate water. In ancient Rome, Nero eliminated his enemies with cherry laurel water, with cyanide being the toxic ingredient (Sidell et al., 1997). Cyanide is present as a salt or acid. Examples of common cyanide salts are sodium cyanide and potassium cyanide. Hydrogen cyanide is the acid form of cyanide. The rest of this paragraph is derived from Manahan (1992). Sodium cyanide and potassium cyanide are both white solids with a bitter, mild almond-like odor in damp air. Cyanide and hydrogen cyanide are used in electroplating, metallurgy, production of chemicals, photographic development, making plastics, fumigating ships, and some mining processes. Other names for sodium cyanide include cyanogran, cyanide of sodium, cymag, hydrocyanic acid sodium salt, and cyanobrik. Cyanide can be found naturally in arrow grass, sorghum, flax, velvet grass,

white clover, and several fruit seeds (apple, apricot, cherry, peach, plum, and others). Copper ions are key to enzyme operation in every aerobic cell. Cyanide binds to the copper ions in these cells deactivating these essential enzymes. The result is chemical asphyxiation by stopping cell aerobic metabolism. Death can result from a 60-90 mg oral dose.

Aldicarb is an extremely toxic carbamate, restricted use insecticide. It is a cholinesterase inhibitor, acting in a similar fashion to the nerve agent VX, causing respiratory failure or cardiac arrest due to central nervous system paralysis, potentially leading to death (Manahan, 1992). Baron (1994) discussed two human studies that showed exposure to 0.1 mg/kg or greater of aldicarb resulted in acute cholinergic signs and symptoms. Krieger (2001) states that the aldicarb toxicity profile for animals and humans is very similar, recommending that the typical interspecies 10x-fold safety factor not be used. This may explain the general lack of data on human oral toxicity.

Cyanide and aldicarb, like thiosulfate, are strong reducing agents. Just as sodium thiosulfate is used to dechlorinate water, sodium cyanide and aldicarb have the same impact on chlorine residual -- they eliminate chlorine instantaneously at low concentrations.

Sodium fluoroacetate, also commonly known as compound 1080, sodium monofluoroacetate, fratol, furatol, ratbane, and yasoknock, is a rodenticide that has been previously used in the United States to control gophers, squirrels, coyotes, and prairie dogs, and is presently banned (Eisler, 1995). Interestingly enough, Verschueren (2001) lists fluoroacetic acid (CAS# 144-49-0) as a chemical warfare agent. Fluoroacetic acid differs from the fluoroacetate ion that makes up sodium fluoroacetate only in the addition

of a hydrogen atom,  $C_2H_3FO_2$ , or in a more protonated form. Sodium fluoroacetate is a deadly human poison by ingestion (Sax and Lewis, 1989). Fluoroacetate poisoning results in a lethal accumulation of citric acid, which in turn causes violent convulsions and death from cardiac failure or respiratory arrest (Teter, 2002).

Prager (1996) describes sodium arsenate, also known as arsenic acid disodium salt, disodium arsenate, and sodium arsenate dibasic, as a clear, odorless powder that is very soluble in water. Sodium arsenate has been previously used in anti-malarial medicine and as an insecticide. Its present uses include poison on fly-papers, toxic ingredient in ant syrups, and as a wood preservative. Norman (1998) states that arsenic can be found in two oxidation states, III and V. This is significant in that the toxicity of arsenic is directly related to its oxidation state. Generally, the arsenic(V) is more chronically toxic, with its toxicity likely a result of its reduction to arsenic(III). Arsenic(III) is acutely toxic, and effects key enzymes including acetylcholine esterase (similar to aldicarb). Chlorine will oxidize arsenic from its most toxic state  $As^{+3}$ , to  $As^{+5}$  (Teter, 2002). A distinction should be made between arsenic acid and arsenous acid. Arsenic acid,  $H_3AsO_4$ , is the fully protonated form of the arsenate ion,  $AsO_4^{-3}$ , which will be used in this study. Arsenous acid,  $H_3AsO_3$ , is similar, but with very different acidity constants. Arsenic acid won't likely effect the pH when introduced to drinking water, with pKa's of 2.24, 6.76, and 11.60. Arsenous acid will increase the pH when introduced to drinking water in high enough concentrations, with pKa's of 9.23 and 12.10 (Benjamin, 2002).

## **2.4 Contaminant Specific Versus Water Quality Surrogate Monitors**

Once it has been determined that on-line monitoring is a feasible approach to continuously monitor the distribution system, one consideration is whether to monitor for specific contaminants (e.g. sodium cyanide, aldicarb) or to monitor for changes in water quality parameters (e.g. pH, conductivity, chlorine residual, turbidity) that indicate that a contamination event has taken place. At this point, both approaches need to be considered.

Monitoring water quality parameters in the distribution system continuously is considered to be an effective approach for detecting chemical contamination events. During a chemical contamination event, the chemical will influence changes in water quality parameters, relative to the concentration of the contaminant in the system, and induce a water quality instrument response. One advantage to using water quality surrogates is the ability to cast a wider net -- to be able to detect a potentially unlimited number of contaminants with the right suite of instruments.

This same point highlights a major disadvantage of using contaminant specific monitors. Several government agencies have increased the funding of research and development efforts aimed at new technology for contaminant specific detection. Even though considerable additional research in this area is needed, there are concerns about the ability to implement this technology due to the potential costs. Another issue associated with the contaminant-specific monitoring approach would be the choice of target chemical and biological agents to measure. If a system was monitoring for five chemical agents that did not include cyanide for example, it might be vulnerable if this information became available to potential terrorists. With the ability of a continuous water quality surrogate monitor to detect a chemical contamination event, an auto-

sampler to capture a sample of the contaminated water, and a toxicity indicator kit to determine toxicity of the contaminant in less than an hour, the potential benefits of knowing exactly what the contaminant was can be postponed.

Radiological contamination is often discounted as a true threat. Since concern of contamination is also a matter of public perception, the resulting panic that may ensue if a drinking water system may have been contaminated with a radiological source would be considerable. Regardless, there is on-line instrumentation available to detect gross alpha, beta, and gamma radiation in water. An example of an on-line radiological monitor is provided in Appendix 1. Again, these are surrogates for radiological contaminants. They do not specify the contaminant, but provide an instrument response that indicates that the water quality has been compromised with a radiological contaminant.

Water quality surrogates as described above will not work directly for toxins. One of the primary challenges with detecting toxins is that they are very toxic at very low concentrations, typically in the sub-microgram/liter range. The impacts to water quality at these concentrations would not likely generate an instrument response. Toxicity indicators have shown some success with detecting toxins at concentrations well below lethal doses. There is information in Appendix 1 on toxicity indicators.

Trying to detect microbiological contaminants presents a totally different challenge. Detecting these contaminants using surrogate water quality indicators does not appear to be feasible *at this point in time*, with only limited potential success. Some toxicity indicator kits use Adenosine Triphosphate (ATP) to indirectly measure viable biomass. Methods that use ATP are limited when being used to try and detect spores or oocysts, because ATP that is generated is linked to a microbe's metabolism. When the

organism is in a dormant state such as an oocyst or spore, the metabolism is essentially shut down, and ATP is not generated in the quantities that a typical viable organism will generate. Another concern is the inability of ATP based tests to detect viruses because they do not exhibit the equivalent metabolic activity. Similarly, portable polymerase chain reaction (PCR) technology is available that will detect specified pathogen contaminants. These test kits are commonly referred to as Ruggedized Advanced Pathogen Identification Device (RAPID), and offer detection in as little as 30-minutes. The drawback of this technology is that it does not appear to be adaptable to on-line applications. Similarly, the toxicity indicators mentioned in the beginning of this paragraph are not presently available in a continuous, on-line mode. There is one model that is projected to be available in the Summer of 2004.

## 2.5 Candidate Instruments And Observables

Table 2-2 provides a summary of potential surrogates per contaminant class that may be considered to detect contamination events indirectly.

**Table 2-2** Potential water quality surrogates per class of contaminant

Chemical Surrogates	Microbiological Surrogates	Toxin Surrogates	Radiological Surrogates
pH	Toxicity indicators	TOC	Alpha
Turbidity	Turbidity	Biomonitors	Beta
Total Organic Carbon	Phosphate	Toxicity indicators	Gamma
Chlorine Residual	High Temp TOC		Toxicity indicators
Conductivity	Nitrate, Nitrite		
Dissolved Oxygen	Chlorine Residual		
Nitrate, Nitrite	Multi-angle light scattering		
Phosphate	Fluorometry		
Oxidation Reduction Potential	Biomonitors		
UV <sub>254</sub>			
Biomonitors			
Toxicity indicators			

Emphasis needs to be placed on the word “potential” that is included in the title for Table 2-2. Appendix A will provide information on continuous instruments that are used in the wastewater industry for nitrate, nitrite, and phosphorous, and may have potential in the drinking water industry.

Some toxicity indicators state that they will work for microbiological and radiological contaminants, but not all. Using toxicity indicators to indicate radiological contamination may have more to do with the heavy metal characteristics and the associated toxicity of the heavy metals than the radioactivity itself. The challenge with determining the appropriate toxicity indicator to use is understanding the method that the toxicity indicator applies, and choosing the right application to satisfy the monitoring need. To better appreciate this, most toxicity screening kits presently use a reduction in luminescence to determine that a toxic contaminant is in the water sample. Examples of three different approaches include an enzyme based chemical reaction that reduces luminescence in the presence of a toxic contaminant, bacteria that will reduce their respiration and hence their luminescence in the presence of a toxic contaminant, and the use of daphnia that when stressed and after the addition of reagents will reduce their luminescence. These three approaches and other screening techniques were evaluated independently in JAWWA (States et al., 2004). A different approach uses a colorimeter or spectrophotometer to measure toxicity based on reduced respiration of bacteria that quantifies the change as a reduction of absorptivity at 603nm. Each of these tests has their own advantages and disadvantages, and each needs to be considered so that the monitoring goal, or the gap that these kits will fill, is adequately addressed. A good place

to look for further information on these toxicity kits and others would be EPA's ETV web-page available at <http://www.epa.gov/etv/verifications/vcenter1-27.html>.

Another potential area for continuous contaminant detection includes the use of biomonitors. As used in raw water supply, a side stream of the source water is directed into a fish tank, and native fish or other fresh water species are used to detect changes in water quality that would be detrimental to the species. Not only do toxic contaminants generate a response, but also contaminants that change water quality enough to irritate the species. The challenge with applying this technology directly to finished drinking water is the residual oxidant. Another challenge includes the maintenance and cost of the bio-sentinels. With continued effort, this may turn out to be an additional tool in continuously detecting contamination events, and may be effective across most contaminant classes.

## **2.6 *Drinking Water Distribution System Parameters***

DeYoung and Gravley (2002) specify that the distribution system provides multiple access points, and is susceptible to injection of contaminants by pumping them in at a higher pressure than the distribution system. The authors further state that some water utility officials believe that the leading threat to the nation's water supply is introduction of a contaminant directly into the distribution system by overcoming system pressure. They emphasize that continuous monitoring capabilities must be developed, that detection is one of three key areas that water supply systems must take action in, and that significant research is needed to detect biological and chemical contaminants.

The focus of this research is on detecting contamination events in the distribution system real-time using water quality parameters that will change significantly in the event

of contamination. The parameters that will be used in this study can be divided into two general categories: those that will be used to detect changes in drinking water quality (pH, chlorine residual, turbidity, conductivity, and TOC), and those that will play a role in simulating the distribution system conditions in the bioreactor (average system pipe diameter, pipe roughness coefficient, temperature, and water velocity).

Of the drinking water quality parameters that will be used in this study, chlorine is cited in the literature the most as providing both a barrier to contamination in the distribution system, and for use in detecting contamination events. The most prevalent disinfectant in the water industry is chlorine, being used by 80% of large and medium sized utilities, with chloramines being a distant second (Macler et al., 2000). Real-time monitoring of the chlorine residual in the distribution system is not a common practice, but is inexpensive (Clark and Deininger, 2000). In order to provide safe drinking water to the entire population, the chlorine residual should be monitored at strategic places in the distribution system (Deininger et al., 2000). Teter (2002) recommends monitoring chlorine and maintaining a strong chlorine residual to deny and mitigate the threat against purposeful contamination. One concern with maintaining an elevated chlorine residual is compliance with disinfectant by-product rules.

In addition to chlorine, turbidity is mentioned as a key parameter to monitor in order to detect contamination. Khan et al., (2001) identify the need for research in areas that would use chlorine residual or turbidity in distribution systems with on-line, remote monitoring to detect changes in these parameters. The Nation Research Council (2002) insists that in order to ensure the safety of the water supply, an adequate disinfectant residual must be maintained in the distribution system, and that the best line of defense

against dangerous bacteria and toxins is maintenance of a high chlorine residual in the distribution system. They emphasize monitoring the chlorine residual real time at representative locations, and stress that the distribution system has the greatest vulnerability to contamination. Like chlorine, the National Research Council provides a variance in turbidity from baseline properties as an example to detect contamination.

Deininger (2000) points out that Denver Water has 14 continuous monitoring stations equipped to measure pH, conductivity, and turbidity in its distribution system. Clark et al. (2002) highlights chlorine residual and pH as having been previously considered in research as surrogate candidates for on-line monitoring of distribution systems. Finally, Landers (2003) emphasizes the interest in monitoring pH, conductivity, chlorine residual, and turbidity while discussing an EPA award to USGS for real-time monitoring research.

Total organic carbon (TOC) is the only parameter in this study that hasn't been noted in the literature, probably due to cost. Regardless, it is an obvious surrogate for the detection of organic contaminants. As the percentage of organic carbon in the contaminant molecule increases, so will a TOC instrument's response to introduction of the contaminant. Some toxins have a large percentage of organic carbon in their molecules, and on the surface may appear to be detected by TOC, but again, at relatively low concentrations, they may not illicit an instrument response significantly above baseline.

Possible scenarios where water quality surrogates may prove useful for detecting microbiological contamination may have more to do with what would be added to the water either with or before introduction of the contaminant, than the contaminant itself.

Examples include a turbid microbiological preparatory solution that may provide nutrients for the microbes before injection, in which case turbidity may be successful at detecting the contaminant. Another scenario may involve the injection of a thiosulfate solution before the microbiological contaminant to significantly reduce the chlorine residual, thus providing the contaminant a better chance of surviving and causing disease. In this scenario, an on-line chlorine residual analyzer would provide a significant instrument response, and would provide indication of contamination.

Phosphate, nitrite, and nitrate continuous monitoring is also available and is currently used in the wastewater industry. Applying this technology to drinking water monitoring offers another option to indirectly determine microbiological contamination in the distribution system. Nitrogen is a component of prokaryotic cells, composing 6-15% of the cell depending on cell type and nutrient conditions (Rittman & McCarty, 2001). Phosphorous is a required element for bacterial growth, is assimilated into cells, and found in nucleic acids, proteins, phospholipids, ATP, and coenzymes. When cells are lysed, phosphate is released. There is typically a stoichiometric relationship between nitrogen in a cell, and phosphate, with cells containing considerably more nitrogen. Utilizing nitrogen and phosphorous as water quality surrogates offer the potential to detect microbiological contaminants, and also to provide more specificity to detecting chemical contaminants. One key consideration to applying this technology to drinking water would be in lysing the cell before the solution was passed through monitors. Common ways to lyse cells include sonication and homogenization.

Multi-angle light scattering (MALS) technology is offering promise for detecting microbiological contaminants in water. This technology is based on laser scattering and

motion analysis to determine the nature and amount of bacteria in a water sample. Adding pattern recognition techniques to the MALS technology has the potential to address the present shortfall in continuous monitoring for microbiological contaminants. The Computing Research Centre at Sheffield Hallam University, Sheffield, United Kingdom is using a MALS device patented by Rustek Ltd, to pursue this opportunity ([http://www.shu.ac.uk/scis/artificial\\_intelligence/biospeckle.html](http://www.shu.ac.uk/scis/artificial_intelligence/biospeckle.html)).

Another option to detect microbiological contamination in water includes the use of fluorometry. This technology has been applied to the continuous analysis of source waters for chlorophyll-a and algal biomass. In addition, it has been demonstrated to work with E-coli (Samset et al., 2000) off-line. A continuous monitoring instrument has been developed and is highlighted in Appendix A (keyword Colifast). Fluorometry offers considerable flexibility in choosing microorganisms to monitor for. It is based on the excitation and emission wavelengths of fluorescent compounds that would become indicative of contamination as the number of bacteria increase in population, and enzymes in the bacteria react with the fluorescent dyes to luminesce.

## **2.7 Sample Collection For Further Analysis And Evidence**

Whether the detection method includes the use of water quality surrogates, contaminant specific technology, toxicity indicators, or the use of biomonitors, once a contamination event becomes evident, several processes need to take place. The first step needs to be human verification. Did the instruments respond to a planned change in water quality such as a change in source water, flushing, change in treatment plant operation, or a series of other potential water quality changing events, or was there really a significant deviation from baseline for an event that needs to be investigated?

Regardless, it is likely that the slug of water as it passed by the detector would be key to determining what exactly triggered the indication of a contamination event.

Consideration should be given to the use of auto-samplers in conjunction with the installation of continuous monitors. Ideally, if a monitor triggers an alarm for an anomalous event, it would initiate the start of an auto-sampler to capture a sample of the slug for further analysis and evidence of the event. Again, a disadvantage of using an auto-sampler includes cost, but "catching up" to the slug of contaminated water after an alarm was triggered to collect a grab sample manually would be challenging. Another key piece of information significant to sample collection or maintenance of evidence is the data log of the anomalous event, providing a location of the instrument that spiked and the time. This will likely be provided via Supervisory Control and Data Acquisition (SCADA) system software, and will be key to determining the potential source of contamination and the required time to respond. Finally, chain of custody must be established for all samples that are collected and taken from a particular location.

## **2.8 Public Health Indicators**

The options provided above do not satisfactorily address the threat. Even in the best scenario, there will still be vulnerabilities in the distribution system that will not be addressed with continuous monitoring. Continuous monitoring in the distribution system adds another barrier to contamination, but like a residual chemical oxidant, does not provide a 100% guarantee that the drinking water is contaminant free. This emphasizes the significance of the public health system to note anomalous behavior. When private physicians or emergency rooms note an unusual frequency of gastrointestinal disruptions in the population, or pharmacies cannot maintain standard stock levels of anti-diarrhea

over-the-counter medications, public health agencies need to be notified. Another consideration may be noting unusual behavior or illness in household pets. Due to their body weight, and the fact that some animals are more sensitive to certain contaminants, pets may provide an early indication that something is wrong. Adding veterinarians to the public health mix could only help. Additionally, if relationships exist between public health agencies, local physicians, veterinarians, and water supply personnel, informal notifications are usually quicker in initiating investigations and can be very productive. This is one of the valuable lessons learned in Milwaukee that all organizations can always strive to be better at, inter-organizational communication.

## **2.9 *Equipment Maintenance Considerations***

This section will highlight general maintenance issues to aid in deciding which types of instruments to select. One of the first questions that needs to be answered includes the monitoring objective. If it is anticipated that numerous monitors will be purchased to place in a distribution system, emphasis should be placed on identifying the appropriate sensor(s) with plans to purchase the same sensor to place in numerous locations. This type of standardization will allow a reduced spare parts inventory, and minimized training requirements. Another consideration includes the use of life-cycle cost analysis to determine the impact of platform, communications, support equipment, waste stream handling/drainage, maintenance, reagents, and replacement costs.

This becomes particularly significant when comparing wet chemistry analyzers to multi-sensor probes that are becoming more abundant on the market. Wet chemistry analyzers require reagents, and significant supporting infrastructure, while multi-sensor probes often have expensive microchip replacements that occur annually or semi-

annually. Other issues that should be considered when comparing monitors includes the frequency of required cleaning to prevent fouling, calibration frequency and requirements, self diagnostics to ensure valid results, requirements necessary to keep the system operational, and the potential to incorporate new technologies as they become available.

### **2.10 Microbiological Simulation Of The Distribution System**

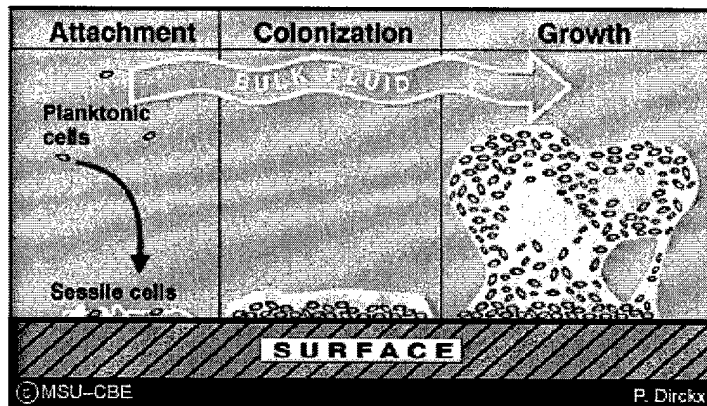
Drinking water distribution systems can not be characterized or simulated thoroughly without consideration of the microbiological factors, particularly biofilms. Biofilms are encountered on a regular basis in daily life. Bacterial biofilm makes up the plaque that forms on your teeth that causes tooth decay. Rocks in lakes, rivers, or streams are often coated with a slimy layer of biofilm.

Montana State University's Center for Biofilm Engineering (available at <http://www.erc.montana.edu>) provides the following description of biofilms: "Biofilm forms when bacteria adhere to surfaces in aqueous environments and begin to excrete a slimy, glue-like substance that can anchor them to all kinds of material – such as metals, plastics, soil particles, medical implant materials, and tissue. A biofilm can be formed by a single bacterial species, but more often biofilms consist of many species of bacteria, as well as fungi, algae, protozoa, debris and corrosion products. Essentially, biofilm may form on any surface exposed to bacteria and some amount of water. Once anchored to a surface, biofilm microorganisms carry out a variety of detrimental or beneficial reactions (by human standards), depending on the surrounding environmental conditions."

Biofilms likely exist in all distribution systems, are recognized as part of the normal aquatic system, and are introduced into the distribution system by well-treated,

but non-sterile water (USEPA, 1992). The USEPA describes biofilms as always being in a state of flux, including the processes of attachment, metabolism, growth, product formation, and lastly detachment from the pipe wall.

The distribution system has a steady inflow of algae, bacteria, fungi, nematodes, protozoa, and other microorganisms (Sibille et al., 1998). Living microorganisms and nutrients enter drinking water distribution systems from failures at treatment plants, pipe breaks or leaks, backflow, and cross-connections (Khan et al., 2001). In addition, microbiological contamination can occur via uncovered storage tanks, and water main installation and repair (Kirmeyer et al., 2001). Even water systems that have excellent sanitary practices for main breaks and repair still have contaminant entry into the distribution system (LeChevallier, 1999). LeChevallier estimates that leakage may represent 10-20% of water produced in systems. When these leaks or breaks occur, contaminants can enter the distribution system. In light of this contribution from main breaks and leaks, the majority of microorganisms that colonize the pipe wall in drinking water distribution systems are attributed to the system's source water (Camper, 1996). Figure 2- displays the complex interaction between the bulk fluid, pipe wall, and biofilms.



**Figure 2-2 Biofilm formation**

Microbial cells from the contamination events mentioned above attach to pipe walls and multiply to form a biofilm (USEPA, 1992). The roughness of the pipe wall, usually a factor of the pipe material and condition, is a key factor that influences both attachment and detachment of biofilm. Volk and LeChevallier (1999) state that pipe material may have more influence on biofilm growth potential than the level of organic matter in the system.

Biofilm, as described by the USEPA, create a much more favorable microenvironment than is available in the flowing, bulk phase. Water flowing past attached microorganisms carry nutrients that are required for growth and survival. This favorable microenvironment within the biofilm matrix provides protection to these cells from disinfectants (Percival et al., 2000; Boe-Hansen et al., 2002; Butterfield et al., 2002). This is a key part of this study, as the protection normally offered by the biofilm will be compromised with the introduction of very toxic contaminants at relatively high concentrations, and it is expected that the biofilm will slough-off and will be quantified as an increase in turbidity.

The biofilm matrix is made up of exopolysaccharides that trap and concentrate nutrients (Costerton and Lappin-Scott, 1989). The addition of ammonia to water systems that use chloramines may be adding a source of nitrogen that will support bacterial growth and biofilm formation (Woolschlager et al., 2001). The bulk phase bacteria are susceptible to depletion of nutrients, while the biofilm bacteria are not (Boe-Hansen et al., 2002). These concentrated nutrients may also play a role in recovery of stressed microbes due to disinfection practices (Watters and McFeters, 1990).

The last phase of the biofilm life-cycle is detachment. Percival et al. (2000) classify detachment as erosion of single cells due to shear stresses, sloughing that occurs with cell clusters usually in older biofilms, abrasion by collision of solid particles, human intervention (e.g. the addition of oxidants to drinking water), and predator grazing. The overall accumulation of biofilm on a surface can be determined by subtracting the rate of biomass detachment from the rate of biomass production (Trulear and Characklis, 1982).

This research used a rotating annular bioreactor (RAB) to grow a steady state biofilm representative of the local distribution system. Rotating annular bioreactors have been used extensively in pursuit of understanding biofilm growth in drinking water systems (Butterfield et al., 2002; Lawrence et al., 2000; Ollos et al., 2003, Fleming et al., 2000). After a representative biofilm was grown off-line, contaminants were introduced into the bioreactor to determine sloughing as a function of turbidity and log cell removal.

Advantages of RABs include the capability to simulate factors that influence biofilm growth in drinking water systems, including pipe material and size, near constant shear stress on the coupon surfaces, and a well-mixed bulk phase under turbulent flow

conditions (Lawrence et al., 2000). Other factors that are key to simulate biofilm growth conditions are temperature and chlorine residual.

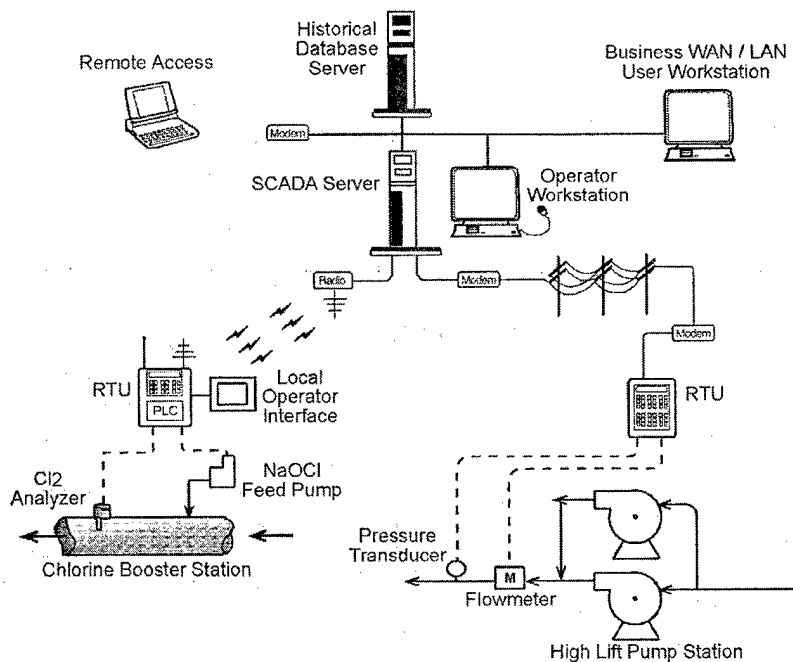
Water temperature is perhaps the most important rate controlling factor regulating microbial growth (LeChevallier, 1989). In water temperatures of 15 C and higher, most investigators have found significant microbial activity (Howard, 1940; Rizet et al., 1982; Fransolet et al., 1985; Donlan and Pipes, 1988; LeChevallier et al., 1990). Ollos et al. (2003) showed that as temperature increased from 8 deg C to 17 deg C, biofilm growth was more affected than at temps of 17-26 deg C, and that generally, steady-state bacterial numbers increase with increasing temperature. The USEPA reports that in the New Haven, Connecticut water system, a two year study reported increases in microbial growth up to and including the highest temperature range of 19.2 C +/- 3.1 (USEPA, 1992). This emphasis on temperature relative to biofilm growth is significant, as the drinking water used in this research has a maximum expected finished water temperature reported as approximately 18 deg C (Fort Collins Utilities Annual Operating Report, 2001). To eliminate the seasonal water temperature impacts in Colorado on biofilm growth, the reactor temperature was set at 15 C +/- 3, using a heat-exchanger in the cooler months.

Butterfield et al. (2002) found that biofilms developed less biomass in chlorinated water than non-chlorinated water. Similarly, Characklis (1988) found that biofilms are more highly developed down stream where the chlorine concentrations are generally lower. Pedersen (1990) hypothesized that the concentration of chlorine at the surface in flowing water is a lot lower than in the fluid itself, providing one explanation for cell

attachment to the pipe wall. Ollos et al. (2003) concluded that the chlorine residual was the most important factor in determining biofilm accumulation.

### **2.11 Data Collection/Formatting Guidance**

Water suppliers typically use Supervisory Control and Data Acquisition (SCADA) technology to acquire, process, and utilize data on-line. SCADA systems include the means for connecting instruments to other system components, including programmable logic controllers, remote telemetry units, and a host computer, as demonstrated in Figure 2-3. Monitoring instruments are connected to remote telemetry units or programmable logic controllers to convert instrument outputs to appropriate units, compare the instrument responses to programmed criteria, generate alarms if required, and send control signals to other equipment. The host computer polls the PLCs and RTUs for data, and in some systems, analyzes this data and provides specified information to system operators.



**Figure 2-3** SCADA system with typical components (AWWARF, 2002)

Factors important in determining which SCADA system to use include life-cycle cost, ease of use, ability to program locally, redundancy of data and system, cyber security, accessibility from remote locations, ability to store, trend, and transfer data, report generation capabilities, graphics, and the ability to communicate with existing software (Pangulari, 2002). Considering security, care should be taken to separate the SCADA system from other internet based software applications to reduce the chance of introducing viruses, and to eliminate the chance of losing control of the system to outside interests. In addition, isolating SCADA systems from other systems will prevent potential system crashes due to systems competing for bandwidth. Other significant factors include the ability to import electronic data from other sources (e.g. laboratory information management systems LIMS), input grab sample results manually as required, two-way communication between the SCADA system and other software applications for

analysis and graphical interpretation of the data, and capability to interface with GIS systems (AWWARF, 2002).

Additional improvements that should be available in newer systems more aligned with signal technology include: the use of digital rather than analog signals to improve resolution, the use of optical fiber technology to improve signal speed and clarity, and continued development and standardization of advanced data analysis techniques to aid in decision making (AWWARF, 2002). Additionally, closed loop systems should be used to continuously signal that the system is working. Table 2-3 provides a summary of important considerations that need to be addressed when utilizing a SCADA system.

In addition, error detection and the reduction of false alarms needs to be discussed. Error detection systems usually incorporate both hardware and software support. Hardware error detection systems typically incorporate alarms similar to those that would be generated for a contamination event. A better approach may be the use of parallel systems, especially when trying to detect anomalous behavior. If both systems generate an alarm condition, then some confidence exists that the particular monitor or SCADA system component is not in error. Software error detection looks for and classifies anomalous behavior.

**Table 2-3** Summary of SCADA system considerations

General Considerations	Security Considerations	Signal Considerations
Life-cycle cost	Isolation of the SCADA system from other internet based software applications	The use of digital rather than analog signals
Ease of use	Ability to import electronic data from other sources	The use of fiber optics technology
Ability to program locally	Input grab sample results manually as required	Advanced data analysis techniques to aid in decision making
Redundancy of data and system	Two-way communication between the SCADA system and other software applications	Closed loop systems
Cyber security	Capability to interface with GIS systems	Error detection systems
Accessibility from remote locations		Parallel systems
Ability to store, trend, and transfer data		
Generation capabilities		
Graphics		
Ability to communicate with existing software		

**2.12 Management Issues Associated With Data Analysis**

On-line monitors should have the capability to store data at the instrument location before it is transmitted to a centralized location. This will ensure that a back-up of the original data is available in the event that any data is lost or changed during transmission. Data that is received from monitoring sites should be reconciled with the data at the instrument locations regularly to ensure data accuracy and completeness. Centralized data management allows the data to be analyzed, whether automatically or with human intervention, before the data is used to generate changes in processes or

generate alarms. This would be an important aspect of reducing false positive and negative signals in a security setting.

**Table 2-4** Summary of management issues associated with data analysis

I	Storage of data at instrument location
II	Reconciliation of data at central site with remote locations
III	Centralized data management
IV	Checklist of known, expected alarm conditions

Alarms will signal anomalous events, and will be triggered for many potential reasons outside of a system breach or contamination event. Water providers should prepare a checklist of known, expected system changes that will likely generate alarms, with annotations as to how the on-line monitors may respond. Examples include:

- changing the source water
- distribution system flushing
- water treatment plant operational changes
- seasonal water quality changes
- source water blending changes
- invalid data points (missing data, data out of range, peaks, or constant values)
- emergency events (e.g. fire hydrant use)

These events and many others should be captured in the system water quality baseline, so that when these events happen and an alarm is triggered, it is easy to identify the source of the alarm, note it, and continue operations if appropriate. Any system with an unacceptable number of false alarms will be quickly discounted by staff. It is imperative that every feasible measure be taken to ensure that this does not happen.

In the event that the data generates an alarm, a standard format for presentation to decision makers must be decided upon. There is a fine line between presenting useful,

timely information, and overwhelming a decision maker with too much information. In general, the following should be presented as a minimum:

- The initial data that generated the alarm including location and time of the event that generated the alarm.
- Verification of this data whether it be in the form of similar instrument responses at multiple locations or secondary analyses like toxicity screening indicators
- Data that would provide information on either the source of the event or a prediction of where the contaminant slug will have the greatest impact -- from hydraulic models or GIS systems
- A brief explanation of exactly what the alarm means in terms that the public would be able to understand
- A list of options that are being considered for mitigation including actions that are required in the short term (e.g. public notification)
- A list of other agencies that need to be informed if the public health of a community is in question. A list containing these agencies and the status of these notifications would be important information for the decision maker to have

### **2.13 Setting Alarm Triggers**

There are two general areas to consider when establishing alarm triggers: the methodology, and the goal of reducing false alarms. Concerning methodology, the use of univariate data analysis may be considered, as well as the chance to use inputs from all instruments simultaneously to detect anomalous behavior--or multivariate analysis.

Univariate analysis looks at one parameter at a time, with the intent of noting a change in a specific parameter or instrument response due to a change in water quality. For example, there are four instruments at a remote location monitoring chlorine residual, pH, turbidity, and conductivity. In response to a change in water quality, the turbidity reading increases significantly. This may be cause for alarm, but at what level, and after how much time? Did the *peak* turbidimeter response indicate a problem, or was there a pre-established alarm of two or three sigma variation from the baseline that generated the

alarm? The important point here is that only the turbidimeter response was considered because it independently set off an alarm, and because it had the most significant instrument response. This single instrument response can be useful when determining instrument response to different contaminants, and also in validating other similar instrument responses in the distribution system when considering potential false positive and negative alarms.

However, multivariate response opens up several opportunities. Those include utilizing the instrument response from all instruments simultaneously to detect anomalies sooner, and to learn more about the changes in water quality to potentially learn something about the cause of the alarm--notably the type of contaminant that generated the alarm.

Regardless of the methodology used, new data points will need to be compared to a baseline. This baseline should be extensive, covering all known potential expected variations. The minimum established baseline may very well include at least a year of data collection to capture seasonal water quality variation, and operational changes that typically occur. Having this baseline, and documenting the effects of normal system changes will be key to reducing false alarms. Univariate analysis may be as simple as setting alarm triggers on each instrument. If the instrument spikes, and is outside of plus or minus three standard deviations from the baseline mean for example, that could identify either an instrument error, or a true water quality degradation. A second similar system, either in parallel or downstream, may be important for determining the validity of this signal. If multiple water quality surrogates were being monitored, it should be suspected that if one water quality parameter (e.g. pH) changed, one would expect to see

a change in conductivity, chlorine residual, or maybe turbidity. This may provide another potential way of validating an alarm condition. The use of multivariate analysis is more sophisticated and would require software to process the data, and turn the raw data into information that could be used by system personnel. One benefit of multivariate analysis may include the option to lower limits of detection of a contamination event, thus providing an earlier warning, and more response time. It may also include not only the trigger of an alarm, but may be able to provide an identification of the contaminant.

The most robust data analysis systems would not choose between univariate and multivariate data analysis systems, but would use both. As expressed previously, univariate analysis offers a built-in instrument check and balance, providing data on what a particular instrument is seeing, and providing the option to compare it to other similar instrument signals. Multivariate analysis offers a potentially quicker trigger of an alarm condition, and in a well established system, the potential to identify the cause of the alarm. Alarm triggers will vary per system, depending on the complexity of the system, its baseline conditions, and ability to support univariate and/or multivariate analysis.

#### **2.14 Cluster Analysis**

Cluster analysis has been considered to apply multivariate analysis to continuous drinking water monitoring data. The goal of cluster analysis is to recognize patterns in the multivariate data, then discriminate between data that appears "normal" and data that may represent an anomaly and hence, generate an alarm condition.

Cluster analysis sorts data into categories. Classical examples may include categorizing students by their grade point average or age. In applying cluster analysis to water quality monitoring, it may classify acceptable water quality into one or more

classes based on water quality indicators such as pH, conductivity, turbidity, chlorine residual, and/or TOC. The goal would be to have an established baseline of water quality data, have it classified into known clusters, so that when a contamination event occurred, a cluster analysis would likely identify a new cluster that would signal an alert indicating that the water quality has been potentially jeopardized. There are several types of algorithms that perform cluster analysis. One of the most popular techniques is the K-means algorithm (Hastie et al. 2001), and will be applied in Chapter 5.

Guler et al. (2002) compared three different multivariate statistical methods for classifying water chemistry data, including k-means clustering. The authors obtained similar results for all three methods, and found that they were “very efficient at grouping water samples by physical and chemical similarities.”

Advanced data analysis is expected to play an important role in getting more information from the abundance of data that on-line instruments generate. The cluster analysis performed as part of this research effort is only a sampling of what may be accomplished. The reader is encouraged to look at other techniques, and to consider likely impacts if the data is pre-processed before applying it to a selected algorithm.

### **2.15 Summary**

As the literature review demonstrates, there is a very definite need for the information that this research effort has produced. The threat of chemical or microbiological contamination to drinking water is well established, and would be an effective way of causing devastating public health consequences. As it presently stands, the technology to detect these contaminants is lacking. Early detection of these

contaminants via on-line or real-time monitoring has been identified as a feasible way to provide early warning to protect public health.

Biofilms likely exist in all drinking water distribution systems to some extent. It would be difficult to properly characterize a drinking water distribution system without consideration of the microbiological impact, particularly biofilms. Rotating annular bioreactors have been used extensively to study biofilms in drinking water distribution systems. They offer several advantages to properly simulate shear stress conditions that biofilms are exposed to while on the pipe wall. Biofilms slough-off (detach) as part of their natural cycle, particularly when conditions aren't in their favor, such as when toxic contaminants are introduced to their environment.

Chlorine residual, pH, conductivity, and turbidity are all referenced in the literature as good choices of surrogates for detecting distribution system contamination. Total organic carbon is not cited, but is an obvious choice to detect organic contaminants. The drawback to on-line TOC analysis is its high relative cost. On-line TOC analysis has proven very helpful in reducing the limit of detection for organic contaminants. If the cost of on-line TOC analyzers proves prohibitive for some utilities, an effort to quantify changes in other water quality parameters when organic contaminants are added to drinking water may offer a viable option.

Toxicity, water solubility, stability, low level of detectability, chlorine or oxidant resistance, availability to the saboteur, and a lack of taste, color and odor, are all key properties of a credible threat contaminant. Given this, the contaminants that were used in this research, sodium fluoroacetate, aldicarb, sodium cyanide, and sodium arsenate, are all very credible water threats.

Chemical contaminants seem to lend themselves to detection by a variety of means, including on-line water quality surrogate analysis, biomonitors, and toxicity indicators. Detection of microbiological contaminants is more elusive, with minimal available technology on-line at the present time, and with many gaps across the contaminant class. Detecting toxins is also difficult, with some promise shown using toxicity indicators. Finally, radiological contaminants can be detected using on-line water quality surrogates specifically for radioactive contaminants, with some promise shown using toxicity indicators -- more an indication of exposure to heavy metals than the radionuclides themselves.

Understanding and knowing the distribution system water quality baseline conditions must be emphasized. Many of the kits and instruments require knowledge of the baseline water quality conditions before the equipment can be applied appropriately. What is typically being looked for is a significant variation in the baseline to provide an alarm condition. Without a thorough understanding of system baseline conditions, trying to appreciate the output of most equipment will be fruitless. Every system will have a different set of baseline conditions.

SCADA systems offer significant capability to transmit data from remote locations, and provide remote control of key resources. In doing so, it must be emphasized that SCADA systems themselves are potentially vulnerable, and that every effort must be made to maximize the effectiveness of SCADA systems while ensuring that they do not add to the vulnerability of a utility. In addition, the capability to receive data from remote locations brings to the surface issues that must be addressed by management such as whether or not to store data at instrument locations, reconciling

data, centralized data management, and developing checklists of known, expected alarm conditions.

Having the most effective SCADA systems and monitoring instruments in your distribution system will not prove beneficial if an exhaustive baseline is not established. All changes in water quality parameters and even toxicity indicators will need to be compared to baseline water quality conditions to determine if a contamination event has occurred. This leads to a look at how these instrument responses should be evaluated. Univariate or multivariate analysis are available for determining alarm triggers. Optimally, a utility would use both techniques to gain advantages in reducing false alarms while potentially lowering limits of detection and providing the identity of a contaminant.

In addition to detecting intentional threat contaminants in a distribution system, real-time monitoring offers the secondary benefit of providing valuable water quality data that may be key to detecting routine water quality compromises associated with line breaks, backflow events, treatment plant failures, or seasonal biofilm sloughing.

This research attempts to address the challenge of detecting an infinitely large number of potential contaminants in a drinking water distribution system real-time. The basic premise of the research is that the readily available and relatively inexpensive equipment can be used with advanced data analysis techniques to determine when a contamination event in a distribution system has occurred. In other words, collect the same data we have been collecting but extract more *information* from this data to satisfy a critical need of the water industry: distribution system security.

## **2.16 Hypotheses**

The literature review above identifies several needs to address drinking water distribution system security. The research that will be presented in this dissertation is designed to address the three hypotheses below:

1. Routine on-line water quality instruments will detect chemical contamination events directly at meaningful concentrations.
2. Biofilm in the distribution system will provide a measurable secondary response to a chemical contamination event and may reduce the detection concentration or limit.
3. Cluster analysis will reduce the time of detection of a contamination event and the concentration that can be detected.

## **CHAPTER 3 UNDERSTANDING VARIATION IN BASELINE DRINKING WATER QUALITY**

### **3.1 Introduction**

This study utilized on-line monitoring of a bench scale distribution system to provide a baseline of local water quality conditions. The initial sample size to establish the baseline was very large. The baseline is key to determining what is "normal," defined as three standard deviations from the mean. Three standard deviations should capture over 99% of data points under normal conditions. Anything outside of three standard deviations represents an anomaly, and should be addressed accordingly.

Drinking water quality fluctuates with temperature, seasonal source water quality, and water treatment plant operations. Because of this, a smaller sample of baseline conditions will be collected before each experiment. This will ensure that any variation due to introduction of contaminants will be compared to conditions in the distribution system that are representative of conditions at the time the experiment was conducted.

A bench scale distribution system had to be built to provide the flexibility that is necessary to measure contaminant-instrument response, and to allow experiments to be run under controlled conditions. The distribution system setup and operation to meet these objectives will be presented later in this chapter.

### **3.2 Objectives**

The initial goal of this study is to establish drinking water quality baseline conditions relative to the distribution system using a large sample size -- over 16,000 data points. A secondary goal includes ensuring that this baseline is re-established on a smaller scale (100 data points) previous to introducing contaminants into the distribution

system. This will be important when accounting for variation in baseline conditions at the time that experiments are conducted.

The objectives of the design and operation of the bench scale distribution system include simulating a pressurized drinking water distribution system with and without the microbiological impacts, supplying enough flow to allow the on-line monitoring instruments to operate as designed, and to satisfy safety and environmental protection concerns.

### **3.3 Bench Scale Distribution System Setup And Operation**

The bench scale distribution system had to be built around a ventilation hood to accommodate the safe introduction of very toxic volatile hazardous materials into the distribution system. In addition, the system was designed to discharge hazardous waste under the ventilation hood to ensure safe handling.

Another consideration was hazardous waste minimization. Once the contaminants were introduced into the system, the resulting effluent from the instrument panels would have to be captured and treated as hazardous waste. To reduce the amount of hazardous waste generated, system volume was minimized while still ensuring enough flow to satisfy on-line instrument requirements. To accomplish this goal, one-inch PVC was used to build the pipe loop, providing a system volume of 4.2-liters. Figure 3-1 provides a diagram of the bench scale distribution system. X's on the diagram represent valves.

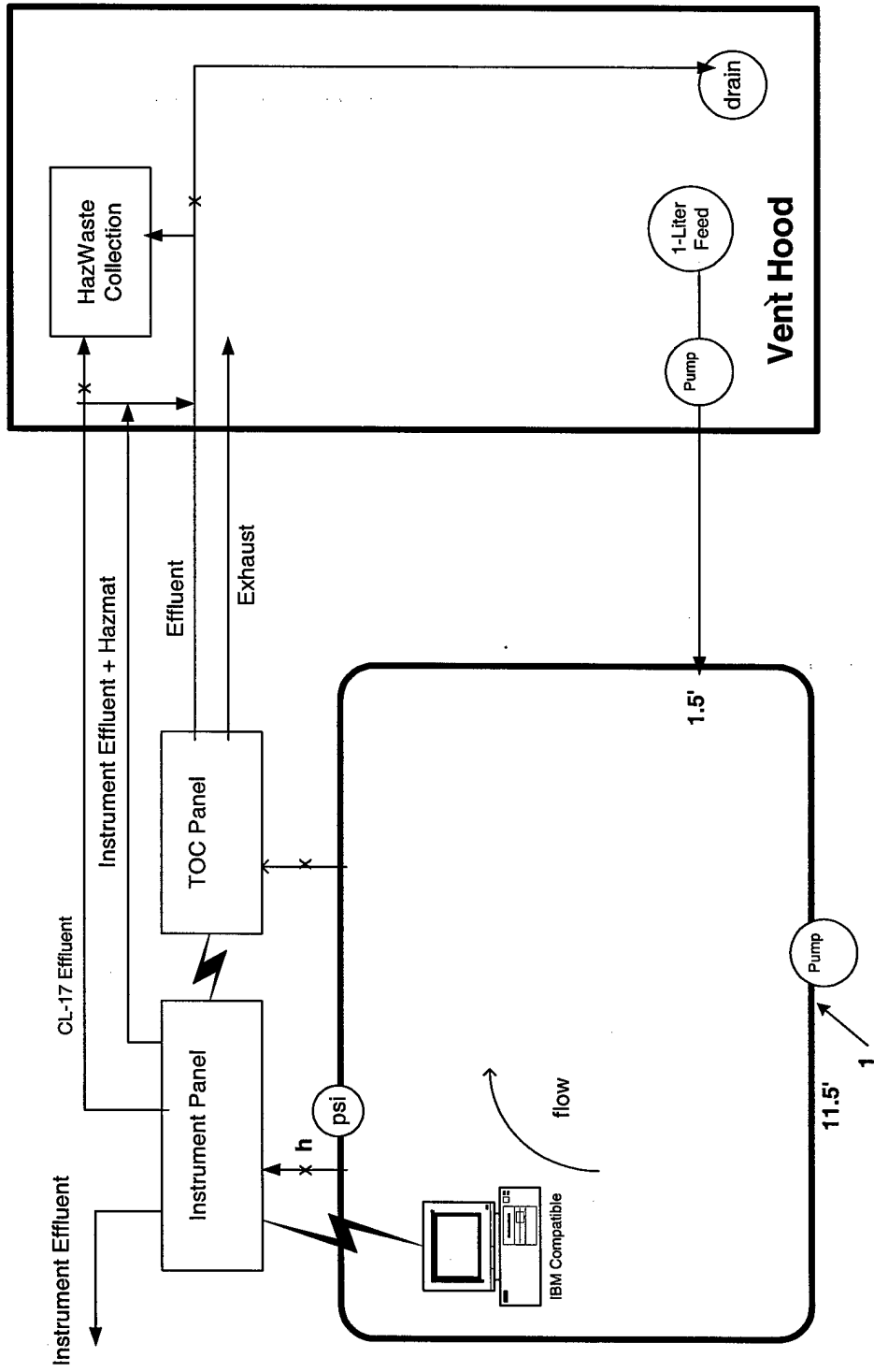


Figure 3-1 Bench scale distribution system schematic

The bioreactors are used to grow a biofilm under conditions that simulate shearing conditions in a local utilities' distribution system, using the average line size, average flow through that line, estimated average velocity, and the Hazen-Williams coefficient for the pipe roughness. The average nominal line size was determined from the information in Table 3-1 (Fort Collins Utilities Annual Operating Report, 2001). Dividing the totals of column C (29,697,624) by column B (2,712,658) provides a nominal average of 10-inches.

**Table 3-1** Pipe size use in Fort Collins distribution system

<b>A</b>	<b>B</b>	<b>C</b>
<b>Size (inches)</b>	<b>Total In Use (Ft)</b>	<b>Size x Total In Use (Ft inches)</b>
3	692	2,076
4	213,554	854,216
6	1,076,488	6,458,928
8	617,962	4,943,696
10	33,942	339,420
12	235,437	2,825,244
16	127,040	2,032,640
18	15,720	282,960
20	70,248	1,404,960
24	115,019	2,760,456
27	72,140	1,947,780
30	28,916	867,480
36	20,843	750,348
42	39,010	1,638,420
48	9,810	470,880
54	5,350	288,900
60	30,487	1,829,220
<b>Total</b>	<b>2,712,658</b>	<b>29,697,624</b>

The average flow through a 10-inch line was then determined by dividing the length of 10-inch line in the system (33,942) by the total length of line in the system (2,712,658), and multiplying this by the average demand (27.3 MGD). This was used to determine the average velocity through a 10-inch line, providing  $v=1$  ft/sec. For PVC pipe, a Hazen-Williams roughness coefficient of 140 was used (Mays, 2000).

All of the above parameters were used to determine an RPM setting that simulated the shear forces in the local utilities' distribution system. The BioSurface Technologies annular bioreactors were run in parallel with the heat exchanger off-line for at least 5-weeks to acclimate to the local utilities' water, and grow a representative biofilm. After a minimum of 5-weeks, a bioreactor was removed from the heat exchanger/parallel setup. Experiments were then performed with the toxic chemical contaminants to determine if biofilm sloughed off and became measurable as an increase in turbidity. Then cell counts were obtained before and after introduction of the contaminant using fluorescence microscopy. The use of three reactors eliminated a potential 5-week lag between experiments, reducing the lag time down to 2-weeks.

The first data collection effort using the bench scale distribution system established the baseline. In this mode the contaminant feed was valved off. The only influent to the system was the tap water from the local distribution system. The only effluent was from the bench scale distribution system to the two panels, and then the non-hazardous waste effluent from the panels themselves to the drain.

The second data collection effort using the bench scale distribution system measured direct contaminant-instrument response. Before contaminants were added, a 100-minute baseline was established to ensure that contaminant-instrument response was compared to water quality just previous to introduction of the contaminants. After the short baseline was established, the system was ready for introduction of contaminants. In this mode the influents to the system included the tap water from the local distribution system, and the contaminants that were pumped in using a peristaltic pump under the ventilation hood. The effluents were from the bench scale distribution system to the two

panels, and then the hazardous waste effluent from the multi-instrument panel. The hazardous waste was redirected from the drain with the use of valves and collected under the ventilation hood.

Finally, the third set of experiments included the use of a bioreactor to determine indirect contaminant-instrument response. Before contaminants were added, baseline turbidity measurements were taken of the tap water, and of the tap water effluent from the reactor. In addition, a  $t=0$  coupon was pulled from the reactor to determine cell counts before the contaminant was added. The bioreactor was drained of all fluid, and was immediately refilled with the contaminant solution. From that point on, turbidity measurements were taken of the reactor effluent and a coupon was pulled from the reactor at  $t=1$ , 8, and 48 minutes. Again, the coupons were later scraped and the cells counted using fluorescence microscopy to determine the log-removal of cells. This step ensured that any turbidity increase after the contaminant was added to the reactor was indeed a result of the biofilm sloughing off.

Distribution system water from the City of Fort Collins was used for these experiments. The results of the experiments with the bench scale distribution system and the bioreactor allowed the study of the effect of contaminants in the distribution system environment itself. The instrument response measured for these experiments was the sum of the signals that are resulting directly from the contaminant and indirectly from the contaminant disrupting the biofilm. The difference between the instrument responses between the experiments with and without the bioreactor is related to toxicity-induced biofilm disruption.

### 3.4 Materials and Methods

The instruments that will measure pH, conductivity, TOC, turbidity and chlorine residual are intended to detect organic and inorganic chemicals, and microbiological contaminants that may be added to the water. In addition, these instruments may detect changes in water quality due to simulated distribution system biofilm disruption caused by acute toxicity. Table 3-2 summarizes the analytical instruments that were used in this study.

**Table 3-2 Analytical instruments used in this study**

Parameter/ Measurement	Method Used	Instrument
<i>Batch analyses</i>		
pH	Standard Method (SM) 4500-H	Fischer Scientific AR-25
Conductivity	SM 2510-B	ECTestr Low conductivity meter
Chlorine Residual	DPD colorimetric SM 4500-C1G	Hach Spectrophotometer
Turbidity	Nephelometry USEPA Method 181.1	Hach DR/3000 spectrophotometer
TOC	UV/persulfate oxidation	Astro autoTOC 1950plus
<i>On-line analyses</i>		
pH	SM 4500-H	Hach EC 310
Chlorine residual	DPD colorimetric SM 4500-C1G	Hach CL-17
Conductivity	SM 2510-B	GLI C53 Conductivity Analyzer
Laser Nephelometer	Nephelometry USEPA Method 10133	Filtertrac 660
Standard Turbidity	Nephelometry USEPA Method 181.1	Hach 1720D/L
TOC analysis	UV/persulfate oxidation	Astro autoTOC 1950plus
Flow	Rotameter	Cole-Parmer

The accuracy of the on-line instruments used in this study is an important attribute. In Chapter 4 the accuracy of this equipment will be a consideration to determine limits of detection per contaminant and water quality surrogate. Table 3-3 provides accuracy of the on-line instruments per manufacturer specification.

**Table 3-3 On-line instrument accuracy**

Water Quality Surrogate	Instrument	Accuracy
pH	Hach EC 310	0.014
Chlorine residual	Hach CL-17	0.05 mg/L
Conductivity	GLI C53	2 uS/cm
Laser Nephelometer	Filtertrac 660	0.005 NTU
Standard Turbidity	Hach 1720D/L	0.01 NTU
TOC analysis	Astro autoTOC 1950plus	0.2 mg/L

The on-line instruments require up to two hours to warm up before readings were considered valid. For this study, the water quality panel and the TOC panel were both started at least the evening before any data was required. In addition, on-line instruments that measure pH and chlorine were calibrated against bench top analytical equipment on a daily basis. The TOC panel, 1720D turbidimeter, and the Filtertrac 660 laser nephelometer were all calibrated before they were placed in service. The TOC panel was calibrated with ethylene glycol per manufacturer instruction. The 1720D turbidimeter was calibrated with diluted 4000 NTU formazine solutions per manufacturer instruction. The Filtertrac 660 laser nephelometer was calibrated with an 800 mNTU formazine solution per manufacturer instruction. The turbidimeter bodies were often emptied and cleaned between experiments.

### **3.5 Challenges**

System pressure was the main challenge. The peristaltic pump in the system that re-circulates distribution system water uses 1/2" MasterFlex tubing that is designed to run at a maximum of 20 psi. Due to this limitation, the tap water flow was adjusted carefully so as not to exceed 20 psi. Water pressure is not regulated on the low side within the ERC. Fluctuations in building water pressure impacted the water pressure in the bench scale distribution system, resulting in low flow to the instruments. This was a particular challenge for the CL-17 chlorine residual analyzer. This was resolved with the addition of a water pressure regulator that was put in the system after the tap. This regulator was used essentially as a pressure reducing valve, allowing the tap to be operated wide open to ensure that whatever the ERC's water pressure was, it would be enough to maintain constant pressure within the distribution system without bursting the 1/2" tubing.

### **3.6 Results/Discussion**

Running tap water was connected to an on-line water quality panel that measured pH, turbidity, conductivity, chlorine residual, and TOC. The water quality in the distribution system was quantified in terms of the baseline conditions, utilizing on-line analytical equipment to capture multiple parameters every minute. Over 20,000 data points were collected between June-October 2003. Over 16,000 of the data points were collected during a two-week period in June 2003, with the remaining 4,000 being collected 100-minutes immediately before the introduction of contaminants into the distribution system during July-October 2003.

The baseline provided valuable information to determine what is "normal" in the distribution system relative to the time that the data was collected. The standard deviation in the on-line baseline data is used in conjunction with the beaker test data to

determine a limit of detection. This provided the first indication on the potential of using water quality parameters as surrogates to detect a contamination event. Appendix B has a one page display of the data as it was collected.

**Table 3-4** On-line monitoring baseline water quality results

	<b>Chl Res (mg/L)</b>	<b>Conduct (uS/cm)</b>	<b>pH</b>	<b>TOC (mg/L)</b>	<b>Turbidity (NTU)</b>	<b>Laser Turbidity (NTU)</b>
<b>Min</b>	0.33	113.91	7.66	1.17	0.08	0.06
<b>Avg</b>	0.52	120.96	7.88	1.92	0.11	0.10
<b>Max</b>	0.86	131.50	8.06	2.24	0.75	1.00
<b>3σ</b>	<b>0.20</b>	<b>14.08</b>	<b>0.25</b>	<b>0.56</b>	<b>0.07</b>	<b>0.12</b>

The data provided in Table 3-4 defines baseline drinking water quality conditions relative to the *date* that the data was collected. This is important, as future studies need to be sensitive to measuring contaminant-instrument response shortly after baseline conditions are established. This strategy was used to conduct beaker tests using sodium fluoroacetate, sodium cyanide, sodium arsenate, and aldicarb. First, the baseline conditions were established using on-line equipment as presented in Table 3-2. This provided a large sample size to estimate the population standard deviation. Miller and Miller (2000) provide a limit of detection equal to the blank signal,  $y_B$ , plus three standard deviations of the blank, or

$$\text{Limit of detection} = y_B + 3s_B$$

In this case, the "blank" signal is zero, as the *difference* between baseline conditions and the addition of a contaminant is what's being measured, leaving three standard deviations as the limit of detection.

Another consideration is the distribution of the data. This is covered in Appendix B.

### **3.7 Summary**

The bench scale distribution system provided the flexibility to conduct controlled experiments to determine contaminant-instrument response in a drinking water distribution system. This was accomplished without compromising simulation of real-world distribution system parameters, including water quality, flow, and the microbiological conditions.

The water quality in the distribution system was quantified in terms of the baseline conditions, utilizing on-line analytical equipment to capture multiple parameters every minute. This resulted in over 20,000 data points providing valuable information to determine what is "normal" in the distribution system relative to the time that the data was collected. The standard deviation in the baseline data will be used to compare beaker test data to the 3-sigma values to determine a limit of detection. This provided the first indication on the potential of using water quality parameters as surrogates to detect a contamination event. Similarly, the baseline data was acquired for 100 data points right before the introduction of contaminants into the distribution system. This ensured that the baseline that the contaminant data was being compared to was representative of system conditions when the experiments were conducted.

The time series plots of the large baseline data set indicate that every parameter behaves differently with respect to time, and that the values of the parameters are in a constant state of flux.

## CHAPTER 4 CONTAMINANT-INSTRUMENT RESPONSE

---

### REAL-TIME DETECTION OF INTENTIONAL CHEMICAL CONTAMINATION IN THE DISTRIBUTION SYSTEM

---

Presented at WEF/AWWA Student Conference, Golden, CO May 2004 and the USAF Environmental Symposium, Nashville, TN March 2004

Submitted to Journal AWWA, March 2004.

#### **4.1 Introduction**

United States drinking water systems are among the greatest engineering and public health accomplishments of the 20th century (Luthy, 2002). It is often taken for granted that when the faucet is turned on, safe water will flow. Concerns over the safety of drinking water, and the security of drinking water distribution systems date back to approximately 300 B.C. during the construction of *Aqua Appia*, one of the aqueducts of the Roman Empire. The Romans were concerned that their water supply systems would be rendered useless by enemy action. To avert this threat, some of their aqueducts were buried up to 50 feet in the ground (Herschel, 1973).

President Clinton signed Executive Order 13010 in 1996 designating water supply systems as one of eight critical infrastructures, "so vital that their incapacity or destruction would have a debilitating impact on the defense or economic security of the United States" (Federal Register, 1996). President Bush signed the Public Health Security and Bioterrorism Preparedness and Response Act into law in 2002 recognizing that, among other things, drinking water systems are vulnerable to intentional acts of sabotage, and that community water systems serving more than 3,300 customers need to take appropriate action to protect public health.

Eighty percent of the US population is served by 14% of the utilities (Clark et al., 2002). This highlights the impact that an act of sabotage to a large drinking water system may have. Water distribution networks have been identified as a major vulnerability. The distribution system is uniquely vulnerable because of its accessibility to those it serves, and the geographic area that it reaches. Khan et al. (2001) highlight the fact that except in the case of aerosols, food or water contamination is the easiest way to distribute chemical and biological agents. Due to the population that a drinking water distribution system serves, a large number of casualties would occur over a wide geographic area. This is particularly alarming when three weeks pass before a source of contamination is identified, as was displayed during the cryptosporidiosis outbreak in Milwaukee during 1993. This incident in and of itself demonstrated the potential for drinking water to serve as a conveyance for the spread of disease.

These incidents affirm the value to public health that an early warning system in the distribution system might have. Early detection of a chemical or biological contamination event is crucial, and could save lives. The use of new agents, combinations of agents, or contaminants that haven't been seriously considered in the past is a very plausible terrorist approach and therefore, the use of surrogates for detection, to cast a broader net, is one approach that needs to be investigated. Early detection is absolutely essential.

This view was highlighted by the National Research Council (2002), who recognized that forced entry of a highly toxic contaminant into the distribution system could have serious consequences. They further declared that monitoring and identification of biological and chemical agents is among the four highest-priority areas

for research on water security. Similarly, Luthy (2002) emphasized the importance of protecting water quality by expediting the detection of contaminants to minimize impacts to human health. The use of multiple barriers in the distribution system, versus just a residual oxidant, was identified as a valid requirement. On-line detection using water quality surrogates for contaminant detection may be considered an additional barrier in the distribution system.

The development and use of real-time monitoring was also recommended by Parmlee (2002) and States et al. (2003) to protect against bioterrorism in water systems. This recommendation was validated when the USEPA awarded a \$500,000 project to the USGS to set up real-time monitoring equipment at two drinking water systems in New Jersey (USEPA, 2002). The significance of this effort is best captured in the USEPA's quote at the onset of the project, "Whether a contaminant enters a water supply system by terrorist action or by accident, it is vital that we have the information to respond quickly. That's why real-time monitoring offers such great promise." In addition, it was emphasized that real-time monitoring will allow water system operators to be aware of potentially dangerous situations before contaminated water reaches consumer taps. Finally, Deininger et al. (2000) summarize it best, "strategically placed monitors in a distribution system is the obvious solution for the protection of a water supply system."

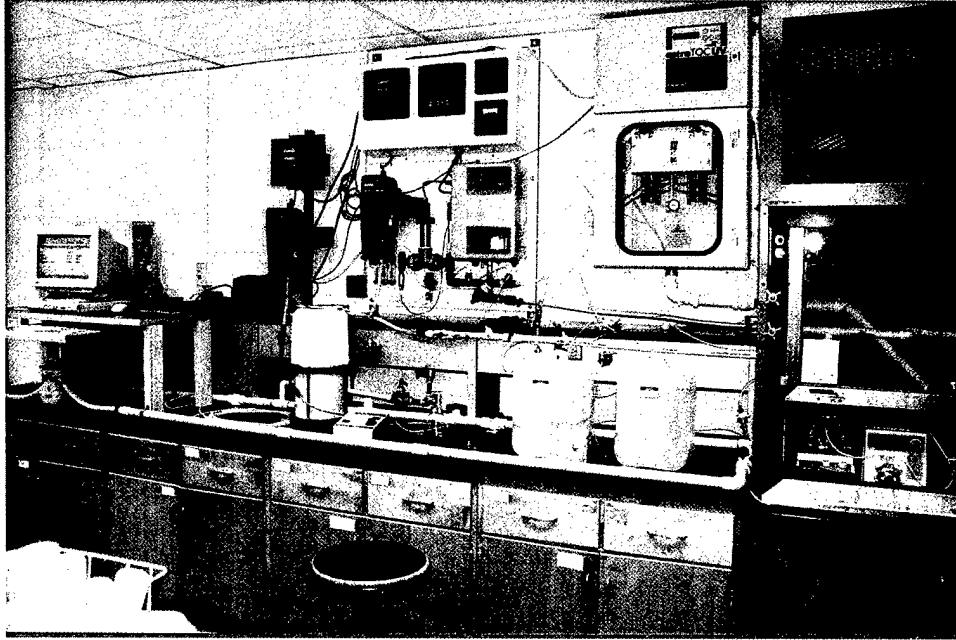
The threat of chemical or microbiological contamination to drinking water is well established, and would be an effective way of causing devastating public health consequences. As it presently stands, the technology to detect these contaminants is lacking. Early detection of these contaminants via on-line or real-time monitoring has been identified as a feasible way to provide early warning to protect public health. This

research is a first step to address the challenge of detecting a large number of potential contaminants in a drinking water distribution system real-time. The basic premise of this research is that readily available and relatively inexpensive equipment can be used to determine when a contamination event in a distribution system has occurred--real time, with the intent being to provide an early warning so that public health is protected.

#### **4.2 *Methods and Materials***

**Baseline water quality data.** Running tap water, via a one-inch PVC pipe loop, was connected to two on-line water quality panels (Figure 4-1): a multi-instrument panel that measured pH, turbidity, conductivity, and chlorine residual<sup>1</sup>; and one that measured TOC<sup>2</sup>. Data was collected once per minute using datalogger software<sup>3</sup>, collecting over 16,000 data points. This data was used to determine what represents "normal" water quality in the distribution system, and to estimate the population standard deviation. In addition, some general information about the distribution of the data was obtained, as well as summary statistics.

Distribution system water quality fluctuates with temperature, seasonal source water quality, flow, demand, and water treatment plant operations. Taking this into consideration, additional 100-minute baselines were collected just prior to the introduction of contaminants into the bench scale distribution system. This allowed for the comparison of the contaminated water with a baseline established immediately before the contaminants were added.



**Figure 4-1** Bench scale distribution system photo

The on-line instruments required up to two hours to warm up before readings were considered valid. For this study, the water quality panel and the TOC panel were both started at least the evening before any data was obtained. In addition, on-line instruments that measure pH<sup>4</sup> and chlorine residual<sup>5</sup> were calibrated against bench top analytical equipment on a daily basis. The TOC panel, turbidimeters<sup>6,7</sup>, and conductivity probe<sup>8</sup> were all calibrated before they were placed in service.

Miller and Miller (2000) define the limit of detection as being equal to the blank signal,  $y_B$ , plus three standard deviations of the blank, or

$$\text{Limit of detection} = y_B + 3s_B$$

In this case, the "blank" signal is zero, as the *difference* between baseline conditions and the addition of a contaminant is what's being measured, leaving three standard deviations as the limit of detection.

The baseline is key to determining the normal signal variation defined as three standard deviations from the mean and this should account for 99.96% of the random variability. Anything outside of three standard deviations represents an anomaly, and should be addressed accordingly (there is a 4 in 10,000 chance that the anomaly is a false positive). The standard deviation in the baseline data will be used to compare beaker test data to the 3-sigma values to determine a limit of detection. This will provide the first indication on the potential of using water quality parameters as surrogates to detect a contamination event. Similarly, the baseline data will also be collected for 100 minutes immediately before the introduction of contaminants into the distribution system. This will ensure that the baseline that the contaminant data is being compared to is representative of system conditions when the experiments were conducted.

**Contaminant selection.** Deininger et al. (2000) identify high toxicity, high water solubility, chemical and physical stability, a lack of taste, color and odor, and a low chance of detection with normal analytical methods as being key properties of credible threat contaminants. For chemical contaminants, Khan et al. (2000) use the following criteria to prioritize contaminant credibility: already known to be weaponized, available to potential terrorists, likely to cause major morbidity or mortality, potential of causing public panic and social disruption, and requiring special action for public health preparedness. They list the following as priority chemical agents: arsenic, pesticides, and cyanides. The National Research Council (2002) addresses morbidity and mortality,

or toxicity, by focusing on cholinesterase inhibitors, including insecticides (e.g. aldicarb), which act like nerve agents, and are persistent in water. These particular contaminants could be injected in high enough concentration to be harmful to consumers, with the only barrier being the disinfectant residual. The US Army Center for Health Promotion and Preventive Medicine listed sodium cyanide and fluoroacetate as priority potential chemical threat agents (Burrows et al., 1997).

It must be stressed that water solubility will frequently be a limiting constraint in determining a credible threat contaminant. Though a lot of potentially highly toxic, and available contaminants are soluble in organic solvents, the solvents themselves contribute a taste, odor, and/or color, or instrument response signature that will in and of itself discredit the contaminant when combined with the solvent from being considered as a credible threat. This was demonstrated when parathion was initially considered in this work.

Contaminants that were used in this research include sodium cyanide, sodium fluoroacetate, aldicarb, and sodium arsenate. Using the criteria specified above, all are considered very credible water threat contaminants.

**Beaker tests.** The chemical contaminants are all commercially available, and in powder form. They were measured using an analytical scale<sup>9</sup>, and mixed with tap water to obtain the desired stock concentration. The beaker tests were conducted using bench top analytical equipment<sup>10-13</sup>. The distribution system experiments used on-line instruments.

After the 16,000 data point baseline was established using on-line equipment, tap water was added to a beaker, and the parameters were measured using bench top

analytical equipment. The four contaminants were then added to the beakers in specified concentrations, and the water quality parameters were measured again, using the same analytical equipment. Finally, the difference was taken between the tap water only measurements and the tap water plus contaminant measurement, and a change in the water quality parameters were determined.

**Bench scale distribution system tests.** The bench scale distribution system provides the flexibility to conduct controlled experiments to determine on-line contaminant-instrument response in a drinking water distribution system. This is accomplished without compromising simulation of real-world distribution system parameters, including water quality, dilution, flow, and pipe materials.

The bench scale distribution system (Figure 4-1) had to be built around a ventilation hood to accommodate the safe introduction of very toxic volatile hazardous materials into the distribution system. In addition, the system was designed to discharge hazardous waste under the ventilation hood to ensure safe handling.

Another consideration was hazardous waste minimization. Once the contaminants were introduced into the system, the resulting effluent from the multi-instrument panel was captured and treated as hazardous waste. To reduce the amount of hazardous waste generated, system volume was minimized while still ensuring enough flow to satisfy on-line instrument requirements. To accomplish this goal, one-inch PVC was used to build the pipe loop, providing a system volume of 4.2-liters.

The first data collection effort using the bench scale distribution system established the baseline. In this mode, the contaminant feed system was not be used. The only influent to the system was tap water from the local distribution system. The

only effluent was from the bench scale distribution system to the two panels, and then the non-hazardous waste effluent from the panels themselves.

The second data collection effort using the bench scale distribution system measured direct contaminant-instrument response. Before contaminants were added, a 100-minute baseline was established to ensure that contaminant-instrument response was compared to water quality just previous to introduction of the contaminants. After the short baseline was established, the system was ready for introduction of contaminants. The influents to the system included the tap water from the local distribution system, and the contaminants that were pumped in using a peristaltic pump<sup>14</sup>. The effluents were from the bench scale distribution system to the two panels, and then the hazardous waste effluent from the multi-instrument panel. The hazardous waste was redirected with the use of valves and collected under the ventilation hood for proper disposal.

The on-line equipment was started up the night before any distribution system experiments were conducted. In addition, once the peristaltic pump<sup>15</sup> that re-circulates the system water was turned on, it took 1-2 hours for the on-line equipment to stabilize. This is due to the increased flow and turbulence in the system, stirring up particulate matter that may have settled onto the PVC piping. After the monitoring equipment had returned to steady state, and had shown consistent readings, the 100-minute baseline data collection began.

#### **4.3 Results and Discussion**

**Surrogate selection.** DeYoung and Gravley (2002) specify that the distribution system provides multiple access points, and is susceptible to injection of contaminants by pumping them in at a higher pressure than the distribution system. The authors further

state that some water utility officials believe that the leading threat to the nation's water supply is introduction of a contaminant directly into the distribution system by overcoming system pressure. They emphasize that continuous monitoring capabilities must be developed, that detection is one of three key areas that water supply systems must take action in, and that significant research is needed to detect biological and chemical contaminants.

The focus of this research is on detecting contamination events in the distribution system real-time using water quality parameters that will change significantly in the event of contamination. The parameters that will be used in this study to detect changes in drinking water quality include chlorine residual, turbidity, pH, conductivity, and TOC.

Of the drinking water quality parameters that will be used in this study, chlorine is cited in the literature the most as providing both a barrier to contamination in the distribution system, and for use in detecting contamination events. The most prevalent disinfectant in the water industry is chlorine, being used by 80% of large and medium sized utilities, with chloramines being a distant second (Macler et al., 2000). Real-time monitoring of the chlorine residual in the distribution system is not a common practice, but is inexpensive (Clark and Deininger, 2000). In order to provide safe drinking water to the entire population, the chlorine residual should be monitored at strategic places in the distribution system (Deininger et al., 2000).

The Nation Research Council (2002) insists that in order to ensure the safety of the water supply, an adequate disinfectant residual must be maintained in the distribution system, and that the best line of defense against dangerous bacteria and toxins is maintenance of a high chlorine residual in the distribution system. They emphasize

monitoring the chlorine residual real time at representative locations, and stress that the distribution system has the greatest vulnerability to contamination. Like chlorine, the National Research Council provides a variance in turbidity from baseline properties as an example to detect contamination. Khan et al., (2001) identify the need for research in areas that would use chlorine residual or turbidity in distribution systems with on-line, remote monitoring to detect changes in these parameters.

Deininger (2000) points out that Denver Water has 14 continuous monitoring stations equipped to measure pH, temperature, conductivity, chlorine residual, and turbidity in its distribution system. Clark et al. (2002) highlights chlorine residual and pH as having been previously considered in research as surrogate candidates for on-line monitoring of distribution systems. Finally, Landers (2003) emphasizes the interest in monitoring pH, conductivity, chlorine residual, and turbidity while discussing an EPA award to USGS for real-time monitoring research.

Total organic carbon (TOC) is the only parameter in this study that hasn't been noted in the literature, probably due to cost. Regardless, it is an obvious surrogate for the detection of organic contaminants. As the percentage of organic carbon in the contaminant molecule increases, so will a TOC instrument's response after introduction of the contaminant.

Chlorine residual, turbidity, pH, and conductivity, are all referenced in the literature as good choices of surrogates for detecting distribution system contamination. Total organic carbon is not cited, but is an obvious choice to detect organic contaminants. The drawback to on-line TOC analysis is its high relative cost. Further work may be directed at how effective the other water quality surrogates (chlorine residual, turbidity,

pH, conductivity) are at detecting organics without the use of TOC to eliminate this costly equipment from the suite of instruments required to provide robust early warning in the distribution system.

**Baseline.** The water quality in the distribution system is quantified in terms of the baseline conditions, utilizing on-line analytical equipment to capture multiple parameters every minute. Over 20,000 data points were collected between June-October 2003. Over 16,000 of the data points were collected during a two-week period in June 2003, with the remaining 4,000 being collected 100-minutes immediately before the introduction of contaminants into the distribution system during July-October 2003.

The baseline provided valuable information to determine what is "normal" in the distribution system relative to the time that the data was collected. The standard deviation in the on-line baseline data is used in conjunction with the beaker test data to determine a limit of detection. This will provide the first indication on the potential of using water quality parameters as surrogates to detect a contamination event. The data provided in Table 4-1 defines baseline drinking water quality conditions relative to the *timeframe* that the data was collected.

**Table 4-1** On-line monitoring baseline water quality results

	<b>Chl Res (mg/L)</b>	<b>Conduct (uS/cm)</b>	<b>pH</b>	<b>TOC (mg/L)</b>	<b>Turbidity (NTU)</b>	<b>Laser Turbidity (NTU)</b>
<b>Min</b>	0.33	113.91	7.66	1.17	0.08	0.06
<b>Avg</b>	0.52	120.96	7.88	1.92	0.11	0.10
<b>Max</b>	0.86	131.50	8.06	2.24	0.75	1.00
<b>3<math>\sigma</math></b>	<b>0.20</b>	<b>14.08</b>	<b>0.25</b>	<b>0.56</b>	<b>0.07</b>	<b>0.12</b>

Figure 4-2 displays time series plots of the large baseline data set. The time series plots indicate that every parameter behaves differently with respect to time, and that the values of the parameters are in a constant state of flux.

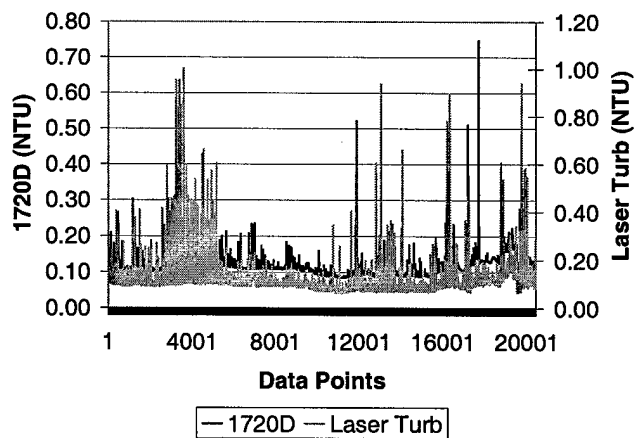
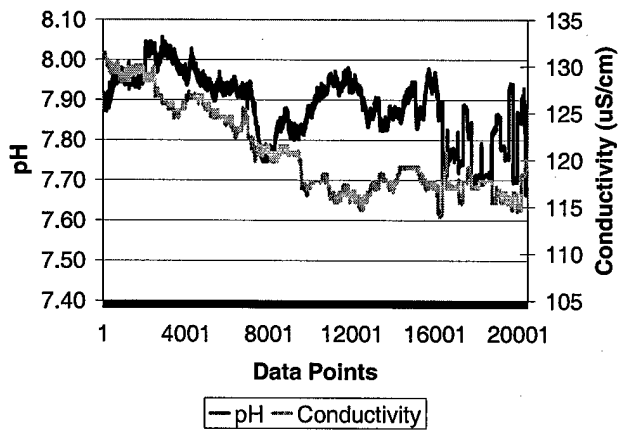
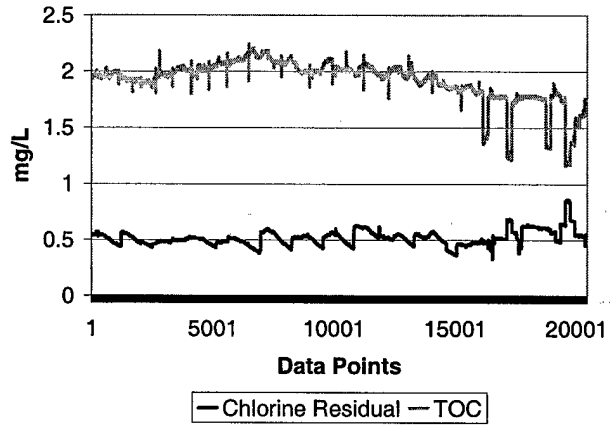


Figure 4-2 Baseline water quality time series plots

Another consideration is the distribution of the data. Histograms were plotted for the data, and all were quite different per parameter, and in most cases it was very easy to see that the data was not normally distributed.

In the case of a suspected normal distribution, for example pH, a look at kurtosis, skewness, and the Anderson-Darling normality test was used in a statistical software package<sup>16</sup> to quantitatively determine if the distribution was normal. Kurtosis measures the peakedness of a distribution, and like skewness, ranges from negative to positive infinity. A kurtosis of zero indicates a Gaussian curve. Positive kurtosis values indicate narrower and more sharply peaked distributions. Negative values indicate flatter distributions. The kurtosis for the pH data was -0.34. Skewness measures the asymmetry of the data. A skewness of zero indicates a Gaussian curve. A positive skewness indicates more values to the left of the mean, a negative skewness indicates more values to the right of the mean. The skewness for the pH data was -0.57.

The Anderson-Darling normality test uses a p-value to test the null hypothesis that the data fits a normal distribution. The criteria for normality is a p-value greater than 0.05. The p-value for the pH data was 0.00 indicating that the data does not fit a normal distribution. Environmental data can typically be fit to a log normal distribution (Gilbert, 1987). Similarly, the Anderson-Darling normality test was used to determine if the data distributions fit a lognormal distribution. All p-values for the different parameters were 0.00, indicating that the distributions are not lognormal.

Since the baseline data does not fit well to a normal distribution, a fair question would be "what exactly is the significance of three-sigma?" Is the assumption that 99.96% of the baseline data under normal conditions will fall within  $\bar{x}$  plus or minus

three-sigma valid? To better understand that, the baseline data was analyzed to specifically answer those questions. Table 4-2 provides the percentage of baseline data points per parameter that fall inside of x-bar plus or minus three-sigma. As Table 4-2 demonstrates, even for data that is not normally distributed, it is fair to state that any data point outside of x-bar plus or minus three-sigma represents an anomaly.

**Table 4-2** Percentage of baseline data points falling within  $\bar{x} \pm 3\sigma$

Conductivity (uS/cm)	pH	Turbidity (1720D) (NTU)	Turbidity (Laser) (NTU)	Chlorine Residual (mg/L)	TOC (mg/L)
100 %	100%	98.34%	98.65%	99.02%	96.58%

Figure 4-2 emphasizes the importance of knowing the baseline water quality real-time in the distribution system, as the water quality is always changing. This is significant, as on-line analysis to detect a contamination event must have an established baseline to compare the suspect data to, relative to the time that the comparison is taking place. In the absence of timely baseline data, the potential exists to inaccurately determine that an anomalous event has or hasn't taken place. In addition, the ideal of assuming that water quality data in the distribution system can be characterized as fitting a classical normal or lognormal distribution may prove to be a large mistake, and nullify any data analysis carried out using such assumptions. Descriptive statistics and determining anomalous events however, could prove very useful.

**Contaminants.** Cyanide has been used for thousands of years as a deadly poison to contaminate water. In ancient Rome, Nero eliminated his enemies with cherry laurel water, with cyanide being the toxic ingredient (Sidell et al., 1997). Examples of common cyanide compounds are hydrogen cyanide, sodium cyanide, and potassium cyanide.

Sodium cyanide and potassium cyanide are both white solids with a bitter, mild almond-like odor in damp air. Cyanide compounds are used in electroplating, metallurgy, production of chemicals, photographic development, making plastics, fumigating ships, and some mining processes.

Copper ions are key to enzyme operation in every aerobic cell. Cyanide binds to the copper ions in these cells deactivating these essential enzymes. The result is chemical asphyxiation by stopping cell aerobic metabolism. Death can result from a 60-90 mg oral dose (Manahan, 1992).

Sodium fluoroacetate, also commonly known as compound 1080 and sodium monofluoroacetate, is a rodenticide that has been previously used in the United States to control gophers, squirrels, coyotes, and prairie dogs, and is presently banned (Eisler, 1995). Interestingly enough, Verschueren (2001) lists fluoroacetic acid (CAS# 144-49-0) as a chemical warfare agent. Fluoroacetic acid differs from the fluoroacetate ion that makes up sodium fluoroacetate only in the addition of a hydrogen atom,  $C_2H_3FO_2$ , or in a more protonated form. Sodium fluoroacetate is a deadly human poison by ingestion (Sax and Lewis, 1989). Fluoroacetate poisoning results in a lethal accumulation of citric acid, which in turn causes violent convulsions and death from cardiac failure or respiratory arrest (Teter, 2002).

Aldicarb is an extremely toxic, restricted use insecticide. It is a cholinesterase inhibitor, acting in a similar fashion to the nerve agent VX, causing respiratory failure or cardiac arrest due to central nervous system paralysis, potentially leading to death (Manahan, 1992). Baron (1994) discussed two human studies that showed exposure to 0.1 mg/kg or greater of aldicarb resulted in acute cholinergic signs and symptoms.

Prager (1996) describes sodium arsenate, also known as arsenic acid disodium salt, disodium arsenate, and sodium arsenate dibasic, as a clear, odorless powder that is very soluble in water. Sodium arsenate has been previously used in anti-malarial medicine and as an insecticide. Its present uses include poison on fly-papers, toxic ingredient in ant syrups, and as a wood preservative. Norman (1998) states that arsenic can be found in two oxidation states, III and V. This is significant in that the toxicity of arsenic is directly related to its oxidation state. Generally, the arsenic(V) is more chronically toxic, with its toxicity likely a result of its reduction to arsenic(III). Arsenic(III) is acutely toxic, and effects key enzymes including acetylcholine esterase (similar to aldicarb). Chlorine will oxidize arsenic from its most toxic state  $As^{+3}$ , to  $As^{+5}$  (Teter, 2002).

Table 4-3 provides information on the toxicity of the water contaminants that were used in this research effort. The minimum concentration in a glass of water to reach the  $LD_{50}$  is based on a 60 kg person drinking a 0.5 L glass of water. In addition, physical and chemical properties of these same contaminants are provided.

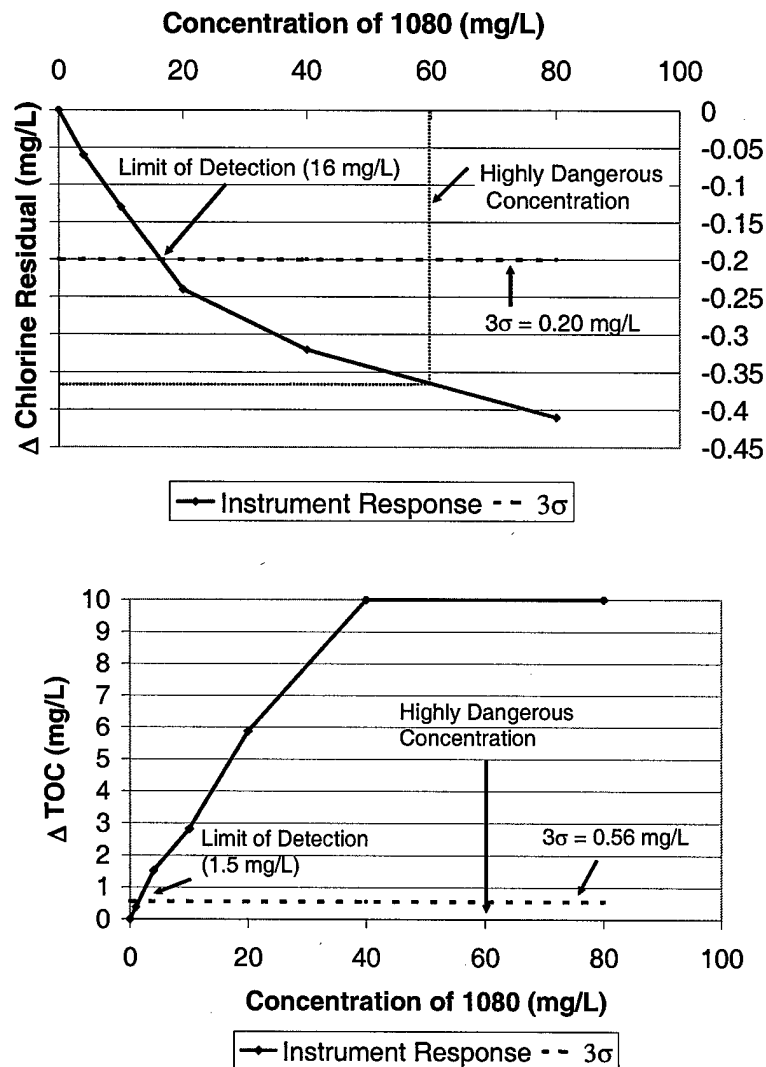
**Table 4-3** Properties of interest for credible threat chemical contaminants

Property	Sodium Fluoroacetate	Aldicarb	Sodium Cyanide	Sodium Arsenate
Human Oral LD <sub>50</sub> (mg/kg)	2-5 <sup>17</sup>	0.8 <sup>18</sup>	3-7 <sup>17</sup>	20 <sup>19</sup>
Min Concentration in glass of water to reach min human oral LD <sub>50</sub>	240 mg/L	96 mg/L	360 mg/L	2,400 mg/L
Life-Threatening Toxicity	60 mg/L <sup>20</sup>	Not available	48 mg/L <sup>21</sup>	14 mg/L <sup>21</sup>
EPA SDWA MCL	N/A	N/A	0.2 mg/L	10 ug/L
CAS #	62-74-8	116-06-3	143-33-9	7778-43-0
Chemical Formula	C <sub>2</sub> H <sub>2</sub> FO <sub>2</sub> Na	C <sub>7</sub> H <sub>14</sub> N <sub>2</sub> O <sub>2</sub> S	NaCN	Na <sub>2</sub> HAsO <sub>4</sub>
Molecular Weight	100.03	190.25	49.01	185.9
Soluble in Water	extremely	0.6 g/100mL	highly soluble, 37 g/100 mL	61 g/100 mL
Stability in Water	t <sub>1/2</sub> =2-6 days in water	Very Stable	Very Stable	Stable

**Beaker tests.** Beaker tests were conducted before the contaminants were introduced into the bench scale distribution system. There were three primary objectives behind conducting the beaker tests: to determine which parameters would be directly influenced by specific contaminants, to determine the approximate minimal concentration that contaminants in a controlled environment would impact water quality, and to anticipate concentrations that would be pumped into the bench scale distribution system.

In addition, the beaker tests served as indicators of the actual concentration that the on-line instruments saw. The contaminants were pumped into the bench scale distribution system at known concentrations, and then diluted due to mixing within the system before flowing through the instrument panels. At this point, the contaminant concentration flowing through the panels was an unknown. The beaker tests provide an indication of the concentration flowing through the on-line panels, similar to a calibration curve.

Figures 4-3 through 4-5 provide changes from baseline water quality parameters after a contaminant was added to tap water at the specified concentration. In addition, toxic contaminant concentrations are provided to allow comparison of the limit of detection and the concentration that would cause potential serious illness. All of the toxic concentrations are much lower than the human oral LD<sub>50</sub> values as indicated in Table 4-3.



**Figure 4-3** Concentration-instrument response for sodium fluoroacetate (1080), chlorine residual, and TOC

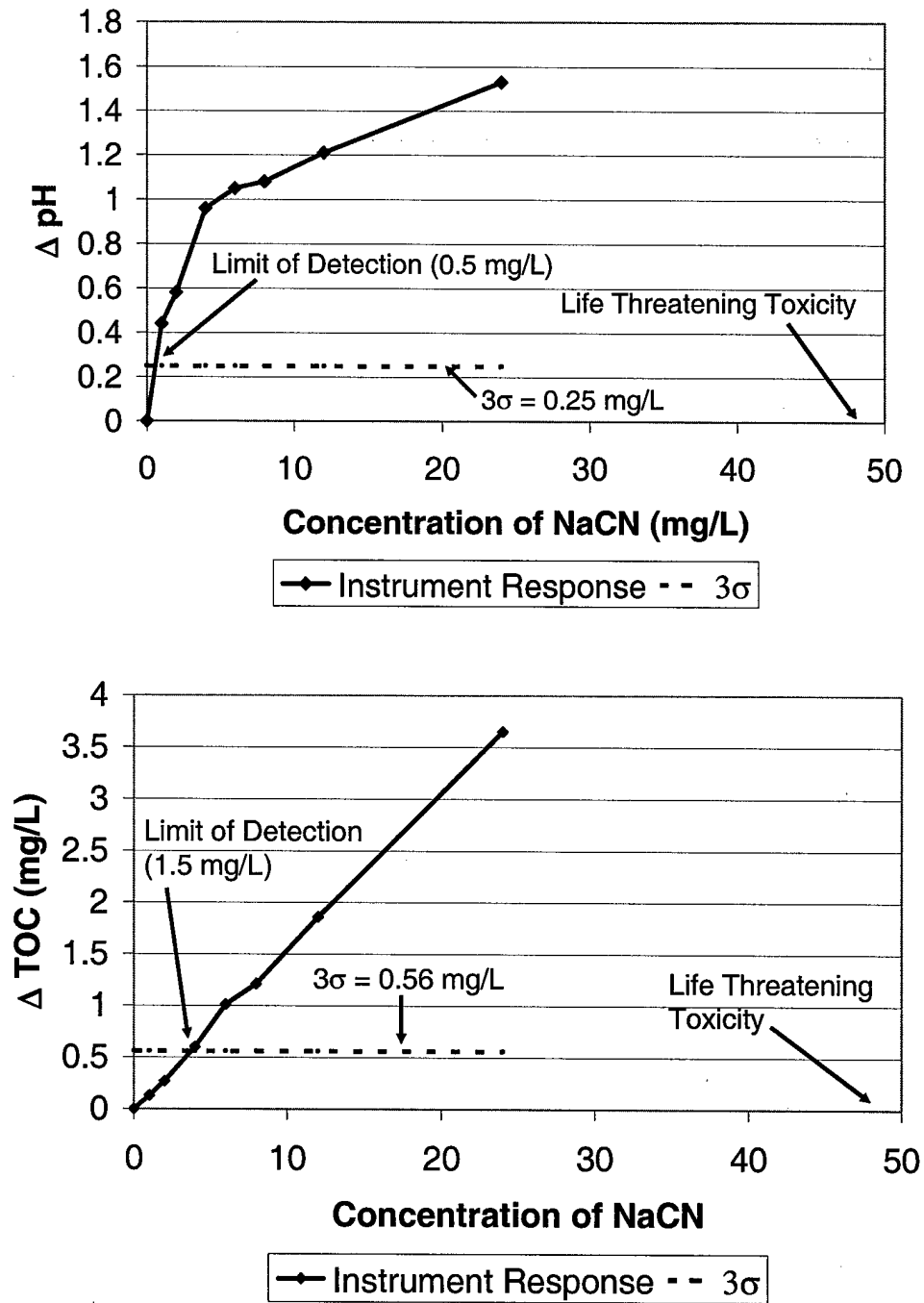
The  $3\sigma$  line represents an estimate for the limit of detection for a contamination event using the water quality surrogate specified. Theoretically, 99.96% of the data points under "normal" conditions will fall within three standard deviations and anything outside of the three sigma line will represent a non-random deviation in the signal. More importantly, as seen in Figures 4-3 and 4-4, the limit of detection is much lower than the corresponding dangerous contaminant concentrations.

As noted in Figure 4-3, the limit of detection of sodium fluoroacetate using a change in chlorine residual is approximately 16 mg/L. This is good news, in that the "highly dangerous concentration" of sodium fluoroacetate is 60 mg/L. Ideally, the goal is always to detect these contaminants at the lowest possible concentration. To be able to directly detect a contaminant at a concentration below that which would result in considerable health impacts is the goal of monitoring.

The TOC curve levels out at the instrument's maximum published TOC range of 10 mg/L. Again, the limit of detection is much lower than the specified concentration that would cause significant health impact. A comparison between the two charts in Figure 4-3 may provide justification for the cost of a TOC analyzer. As can be seen, the TOC analyzer's limit of detection for sodium fluoroacetate was 1.5 mg/L, significantly lower than using chlorine residual (16 mg/L). This result should be expected for organic contaminants, with molecules having more organic carbon being detected at lower concentrations than those having less.

Figure 4-4 provides a similar result. Sodium cyanide was detected well below the "life threatening toxicity" using pH as a surrogate. Of the four contaminants, cyanide

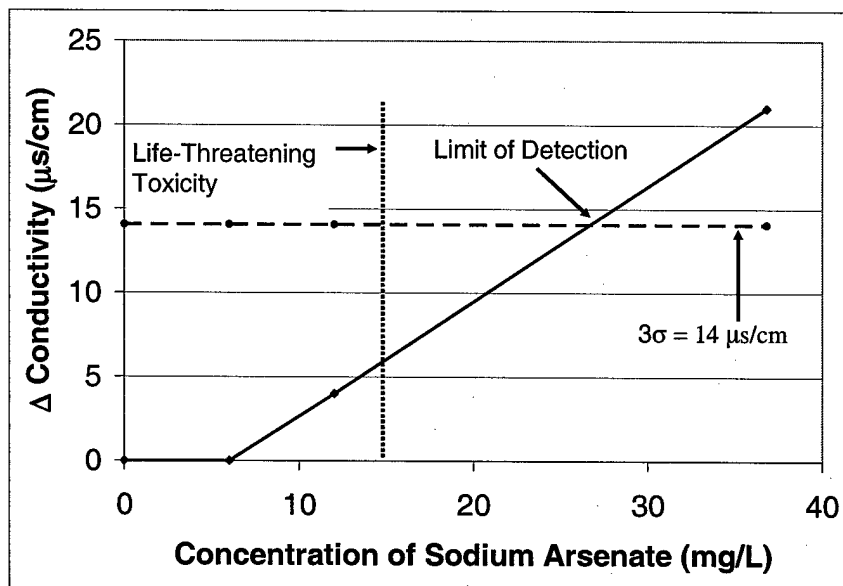
was the easiest to detect, changing all of the water quality parameters significantly at relatively low concentrations.



**Figure 4-4** Concentration-instrument response for sodium cyanide, pH, and TOC

Even though cyanide is an inorganic compound, sodium cyanide elicited a significant instrument response from the TOC analyzer at a concentration well below the point of significant health impact. It is thought that the low-temperature UV-persulfate oxidation analysis method used in the TOC analyzer was not effective at purging the triple-bonded carbon-nitrogen molecule, so the carbon remained and was oxidized to carbon dioxide, and therefore detection as TOC was complete.

Figure 4-5 displays changes in conductivity after varying concentrations of sodium arsenate was added to tap water in a beaker. This figure demonstrates a requirement to reduce the limit of detection for certain contaminants, as direct detection using water quality surrogates will not suffice to protect public health. As can be seen, sodium arsenate is detected *above* the concentration of concern. The published value for sodium arsenate toxicity was the U.S. Army's "life threatening toxicity" for inorganic arsenic of 14 mg/L (USACHPPM TG 230, 2002).



**Figure 4-5** Concentration-instrument response for sodium arsenate and conductivity

Figures 4-3 and 4-4 demonstrate the potential of using on-line water quality monitoring to detect contamination events at concentrations below those that would cause significant health effects. Figure 4-5 demonstrates the need for more sophisticated data analysis techniques to reduce the limit of detection. Consideration may be given to data mining techniques that would take the large quantity of on-line generated data, and use pattern recognition techniques to further reduce the limit of detection obtained by direct on-line analysis. In addition, perhaps using biofilm that is ever-present in distribution systems to provide a secondary response due to cell death and the resultant sloughing-off of biomass due to acute chemical toxicity may provide a reduced limit of detection as well.

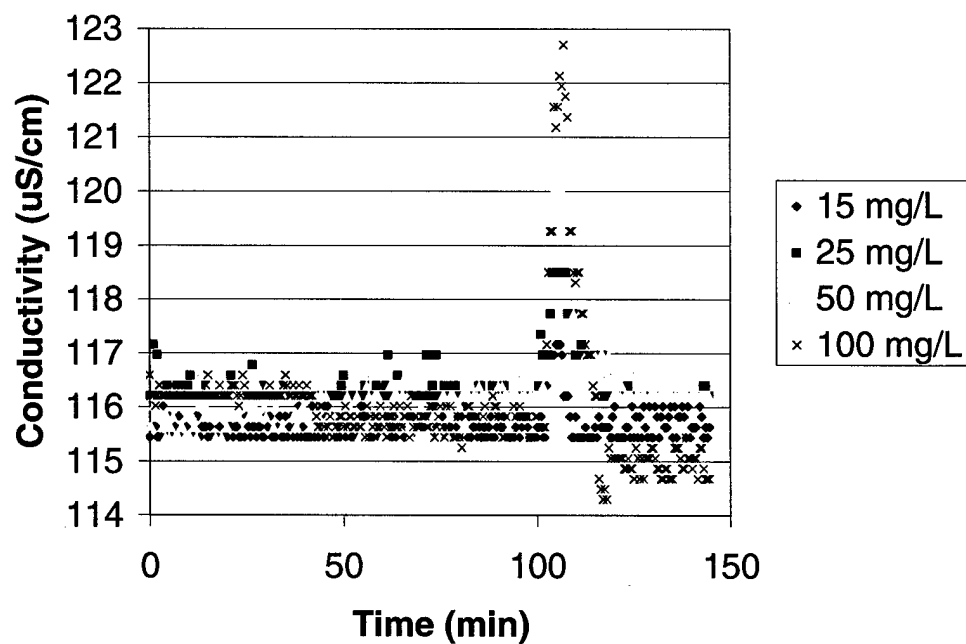
**Bench scale distribution system tests.** Before introducing the contaminants into the bench scale distribution system, data was collected for 100 minutes to determine baseline conditions. The values in Table 4-4 indicate the lowest concentration that the contaminant was detected at using the water quality parameter in the column heading. These values are the result of comparing the change in the water quality parameter to both the three-sigma value from the 100-minute baseline, and the published instrument error. Highlighted values indicate the lowest limit of detection, or a recommended water quality surrogate for detecting that contaminant.

**Table 4-4** Limits of detection for contaminants per water quality surrogate

Contaminant	Chlorine Residual	Conductivity	pH	TOC	Turbidity	Laser Turb
Sodium Arsenate (mg/L)	>100	25	>100	>100	<15	<15
Sodium Cyanide (mg/L)	<0.5	5	1	>10	<0.5	1
Sodium Fluoroacetate (mg/L)	10	10	3	10	3	3
Aldicarb (mg/L)	1	>10	1	3	3	3

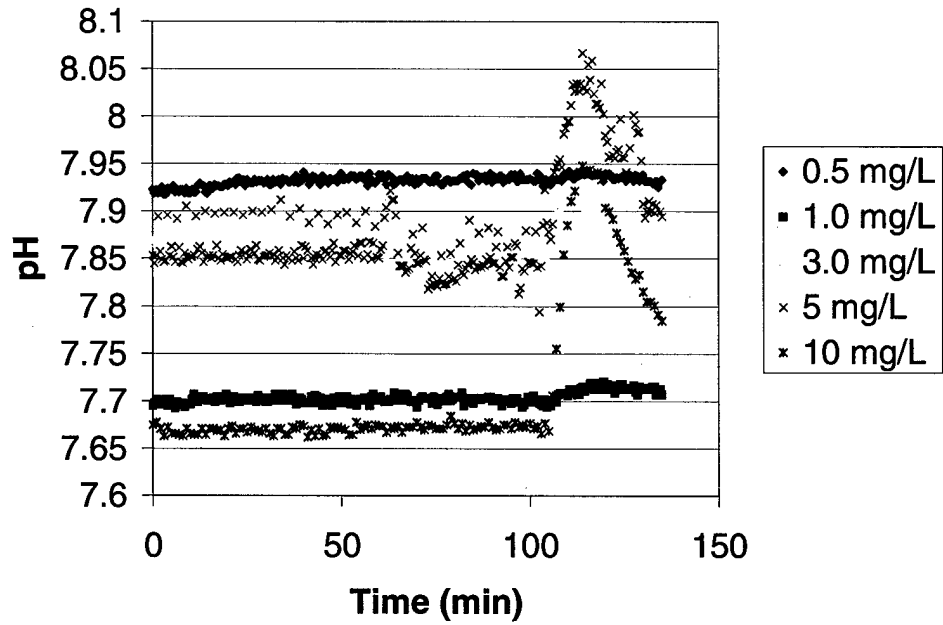
Table 4-4 provides encouraging data. All four contaminants were detected at relatively low concentrations using the on-line equipment, versus three out of the four using the beaker tests and bench top analytical equipment. The key difference is using the on-lines turbidimeters to detect sodium arsenate. The "life threatening toxicity" for inorganic arsenic of 14 mg/L was discussed previously for evaluation of the beaker test data. The on-line data suggests that sodium arsenate may be detected at concentrations below 15 mg/L, or a lot closer to the concentration of concern than conductivity was able to detect (~27 mg/L). The anticipated result of including biofilm results in this type of analysis would be to reduce the limit of detection using turbidity specifically, as the sloughed-off biofilm may result in an increased turbidity instrument response. This combined with statistical pattern recognition may very well reduce the limit of detection to a more acceptable concentration.

Figure's 4-6 through 4-9 are time series plots showing the on-line instrument response after the contaminants are pumped into the bench scale distribution system at varying concentrations. The first 100-minutes are baseline conditions. With the contaminant pump turned on at  $t=100$  minutes, it took four minutes to feed the one-liter of contaminant into the system.

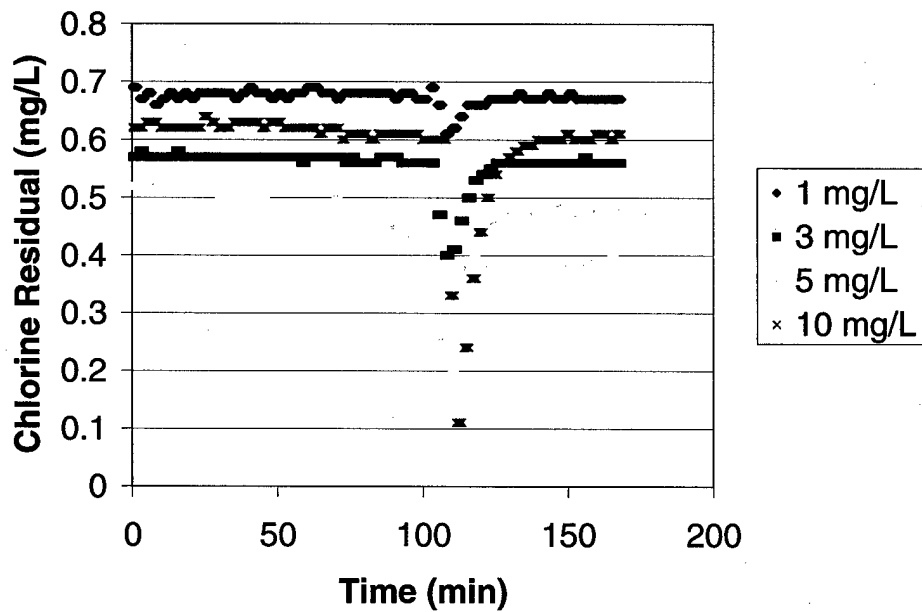


**Figure 4-6** Time series plot of on-line instrument response for sodium arsenate and conductivity

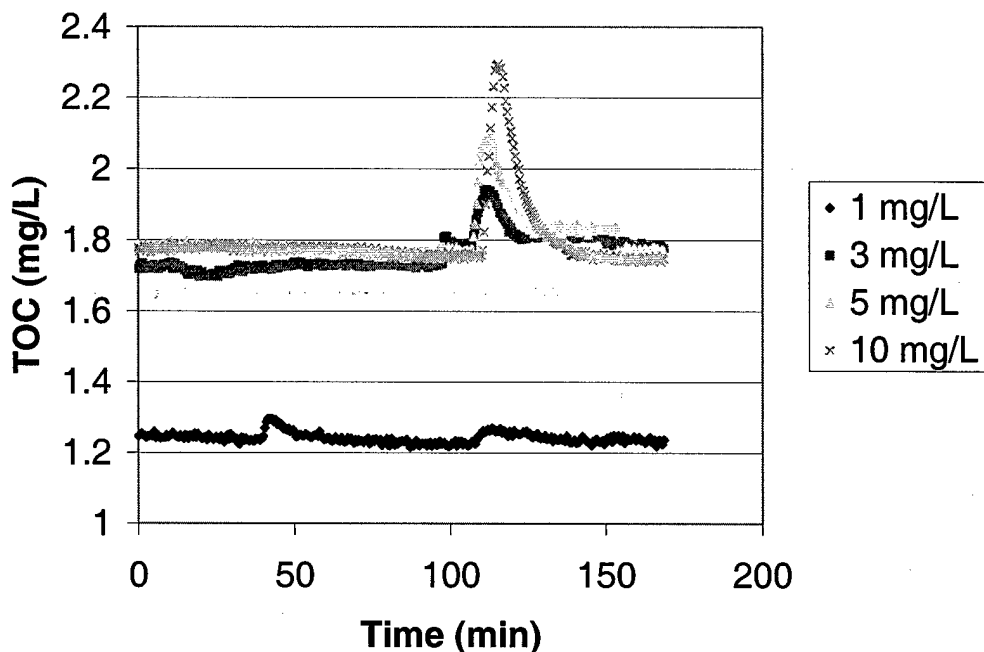
Conductivity showed the most significant instrument response for sodium arsenate. Sodium cyanide and sodium fluoroacetate also had measurable instrument responses for conductivity.



**Figure 4-7** Time series plot of on-line instrument response for sodium cyanide and pH



**Figure 4-8** Time series plot of on-line instrument response for aldicarb and chlorine residual



**Figure 4-9** Time series plot of on-line instrument response for aldicarb and TOC

Sodium cyanide significantly changed all of the water quality parameters at relatively low concentrations. It was the only contaminant that significantly changed pH. Aldicarb affected the chlorine residual quickly, as did sodium cyanide. Aldicarb and sodium fluoroacetate increased the TOC as would be expected, with the aldicarb molecule containing more carbon, and eliciting a more significant instrument response.

#### **4.4 Conclusions**

The threat of chemical or microbiological contamination to drinking water is well established and requires an urgent effort to protect our drinking water systems from malevolent acts of sabotage. As it presently stands, the technology to detect these contaminants is lacking. Early detection of these contaminants via on-line or real-time monitoring has been identified as a feasible way to provide early warning to protect public health.

Results from this study indicate that routine water quality instruments can detect chemical disturbances in drinking water distribution systems at relatively low concentrations. Three of the four contaminants were detected well below concentrations of concern. The fourth, sodium arsenate, was detected near the "life threatening toxicity" concentration using on-line monitoring of turbidity.

In an effort to reduce the limit of detection further, potential may lie in applying statistical pattern recognition techniques to the large data sets available from on-line monitors. In addition, there may be potential to derive some good from biofilms that are typically in distribution systems. By using sloughed-off biomass that may occur after the introduction of a toxic contaminant to a drinking water distribution system, turbidity may increase, signaling a contamination event. Finally, on-line TOC analysis has proven very helpful in reducing the limit of detection for organic contaminants. If the cost of on-line TOC analyzers proves prohibitive for some utilities, an effort to quantify changes in other water quality parameters (e.g. UV254) when organic contaminants are added to drinking water may offer a viable option.

The results of this research indicate that routine monitoring can be used in the distribution system to detect a range of contaminants real-time, potentially providing adequate early warning to take appropriate action and protect public health. In addition to detecting intentional threat contaminants in a distribution system, real-time monitoring offers the secondary benefit of providing valuable water quality data that may be key to detecting routine water quality compromises associated with line breaks, backflow events, treatment plant failures, or seasonal biofilm sloughing.

## FOOTNOTES

- <sup>1</sup>Distribution monitoring panel, Hach Co., Loveland, Colo.
- <sup>2</sup>Astro autoTOC 1950plus process TOC analyzer, Hach Co., Loveland, Colo.
- <sup>3</sup>OPC datalogger, Hach Co., Loveland, Colo.
- <sup>4</sup>GLI P53 pH/ORP analyzer, Hach Co., Loveland, Colo.
- <sup>5</sup>CL17 chlorine analyzer, Hach Co., Loveland, Colo.
- <sup>6</sup>1720D/L low range process turbidimeter, Hach Co., Loveland, Colo.
- <sup>7</sup>FT660 laser light nephelometer, Hach Co., Loveland, Colo.
- <sup>8</sup>GLI C53 conductivity analyzer, Hach Co., Loveland, Colo.
- <sup>9</sup>AE100 Analytical Balance, Mettler-Toledo, Inc., Toledo, OH
- <sup>10</sup>AR25 pH meter, Fischer Scientific, Pittsburgh, PA
- <sup>11</sup>Hach 2100 AN turbidimeter, Hach Co., Loveland, Colo.
- <sup>12</sup>DR/3000 spectrophotometer (for chlorine residual), Hach Co., Loveland, Colo.
- <sup>13</sup>ECTestr Low conductivity meter, Oakton Instruments, Vernon Hills, IL
- <sup>14</sup>MasterFlex 7016-20/7521-40 peristaltic pump, Cole-Parmer Instrument Co., Vernon Hills, IL
- <sup>15</sup>MasterFlex 77601-10/7591-50 peristaltic pump, Cole-Parmer Instrument Co., Vernon Hills, IL
- <sup>16</sup>MINITAB Statistical Software v13, Minitab Inc., State College, PA
- <sup>17</sup>Teter (2002)
- <sup>18</sup>Confidential US Government Report
- <sup>19</sup>Norman (1998)
- <sup>20</sup>Krieger (2001)
- <sup>21</sup>USACHPPM (2002)

**DISCLAIMER:** The opinions and conclusions in this paper are the author's alone and do not necessarily reflect those of the United States Air Force, or the Federal Government.

## CHAPTER 5 CLUSTER ANALYSIS

### 5.1 Introduction

It has been determined to this point that commonly used on-line water quality instruments will detect a contamination event in the distribution system at relatively low concentrations. This chapter will discuss a data analysis technique with the same goal of reducing detection time, or decreasing the concentration that the contaminant is detected at by classifying anomalous clusters of data.

To do this, bivariate plots of the on-line data will be presented to qualitatively show that patterns in the data are obvious at relatively low concentrations of the chemical contaminants. Then similar data files will be used to determine if a pattern recognition technique will quantitatively reduce the time to detect a contamination event, thus providing an earlier warning that the distribution system has been compromised.

One advantage of using on-line monitoring equipment is the large data sets that the monitors produce. Large data sets lend themselves well to applying pattern recognition techniques to distinguish between 'normal' conditions and anomalous conditions that may warrant the triggering of an alarm.

Examples of common pattern recognition techniques used in anomaly detection include the convex hull algorithm, spectral pattern perturbation, artificial neural networks, self organizing maps, and clustering analysis. The convex hull algorithm is commonly used in detecting computer network intrusions, and entails fitting surfaces to vectors in n-space. As new vectors are introduced to the algorithm, it places them into either 'known' (recognized) boundaries, or 'unknown' (anomalous) boundaries. Spectral pattern perturbation looks for changes in time series data to determine normal and

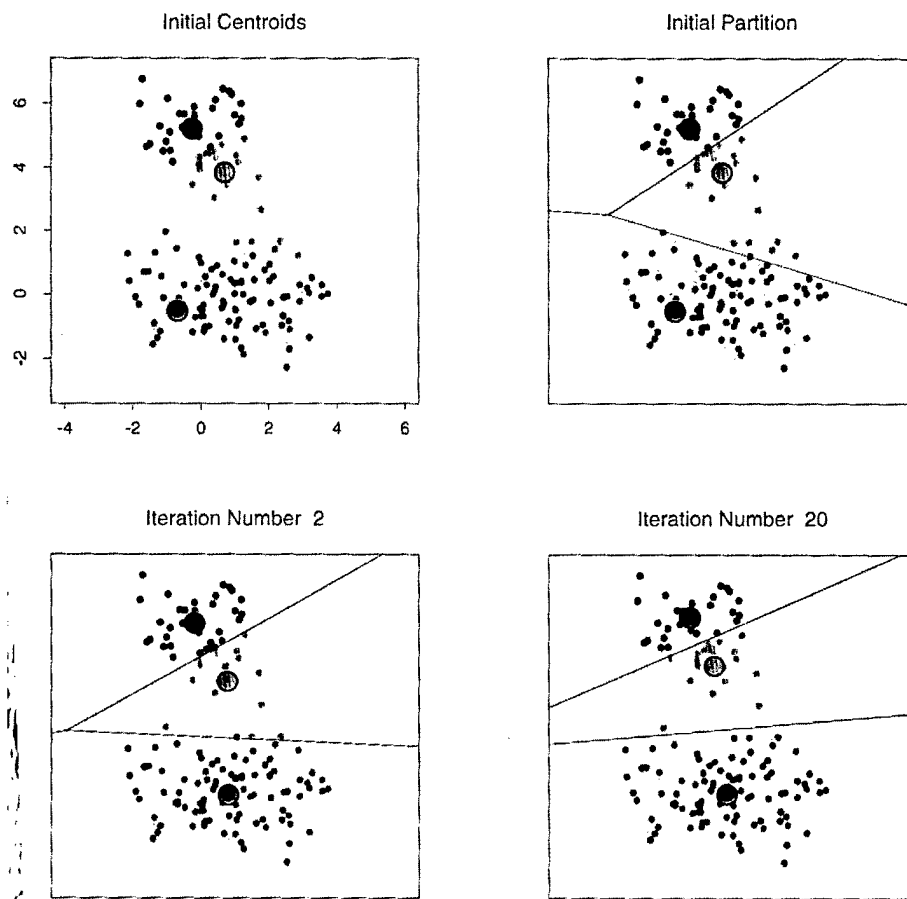
anomalous conditions. An applicable example would include looking for peaks in the on-line water quality instrument time series data. Clustering analysis separates data points into separate clusters. In this effort, an expected clustering would entail separating the data points into two clusters, one representing normal water quality, and one representing anomalous conditions. Artificial neural networks and self organizing maps can be used as non-linear clustering techniques, having the ability to adjust the weights of individual data elements (e.g. TOC or turbidity) before clusters are assigned.

More information on cluster analysis is available locally at CSU's Morgan library. Books that were used to better appreciate cluster analysis in this effort include Allis et al. (2004), Anderberg (1973), Wolff and Parsons (1983), Engelbrecht (2002), Hartigan (1975), Miller and Miller (2000), Hastie et al. (2001), and Matlab's Statistics Toolbox version 4 (2002).

One cluster analysis method that is used extensively includes the k-means clustering algorithm. The k-means algorithm separates the data sets into k mutually exclusive clusters. K-means clustering has been found to be very suitable for working with large data sets, like the on-line data that the water quality monitors have generated. Clustering offers the advantage of providing outputs from multi-dimensional data into two dimensions, and supplying easily recognized decision criteria to determine that a contamination event has occurred -- data points are either in a 'normal' cluster, or a cluster that represents an anomalous event. This is best demonstrated in Figure 5-1.

Figure 5-1 shows data that is broken into three clusters represented by blue, green, and red dots. The respective filled-in circles represent the cluster centroids (means). As the k-means algorithm proceeds through its iterations, it reassigns the cluster centroids

with the goals of minimizing the sum of distances from each object to its respective cluster centroid. The algorithm is considered successful when the distance between objects and their assigned centroid is minimized, and the distance between objects of different clusters (e.g. blue vs. green vs. red) is maximized. A close look at Figure 5-1 will yield a slight difference in both the cluster centroid position and the assignment of clusters for the different points, especially near the cluster partitions, as the algorithm progresses.



**Figure 5-1** Example of k-means clustering by iteration (Hastie et. al, 2001)

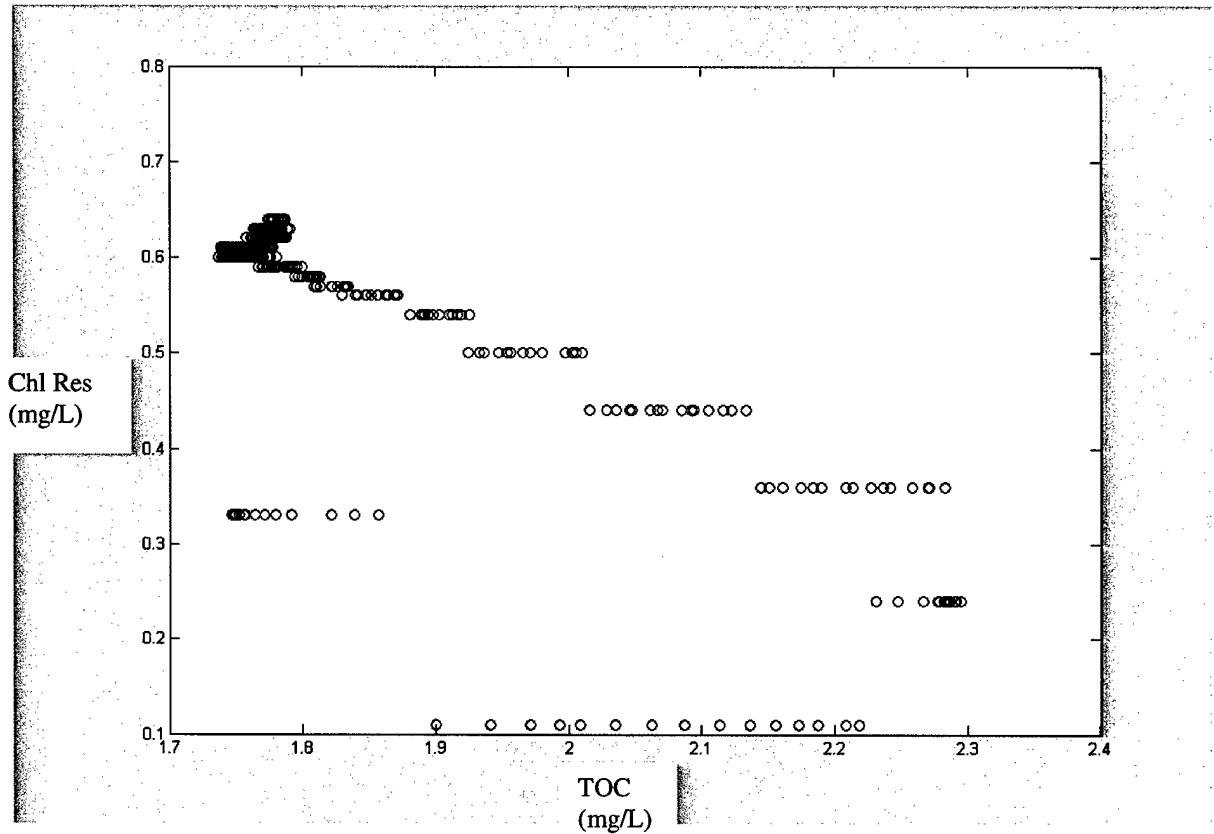
As should be expected, under normal conditions, water quality data should fit nicely into a single cluster. As the water quality changes in response to contamination, it would be expected that the data would fit marginally in the same cluster, or fit better into a cluster of its own. Cluster analysis offers the advantage of utilizing multiple parameters simultaneously to determine water quality, while allowing a single output, the water quality cluster assignment, to determine if the system has been compromised. The assignment of a single output has the advantage of working in single space or two-space, versus trying to conceptualize, for instance, a 6-dimensional space that the water quality data would represent.

## **5.2 *Materials and Methods***

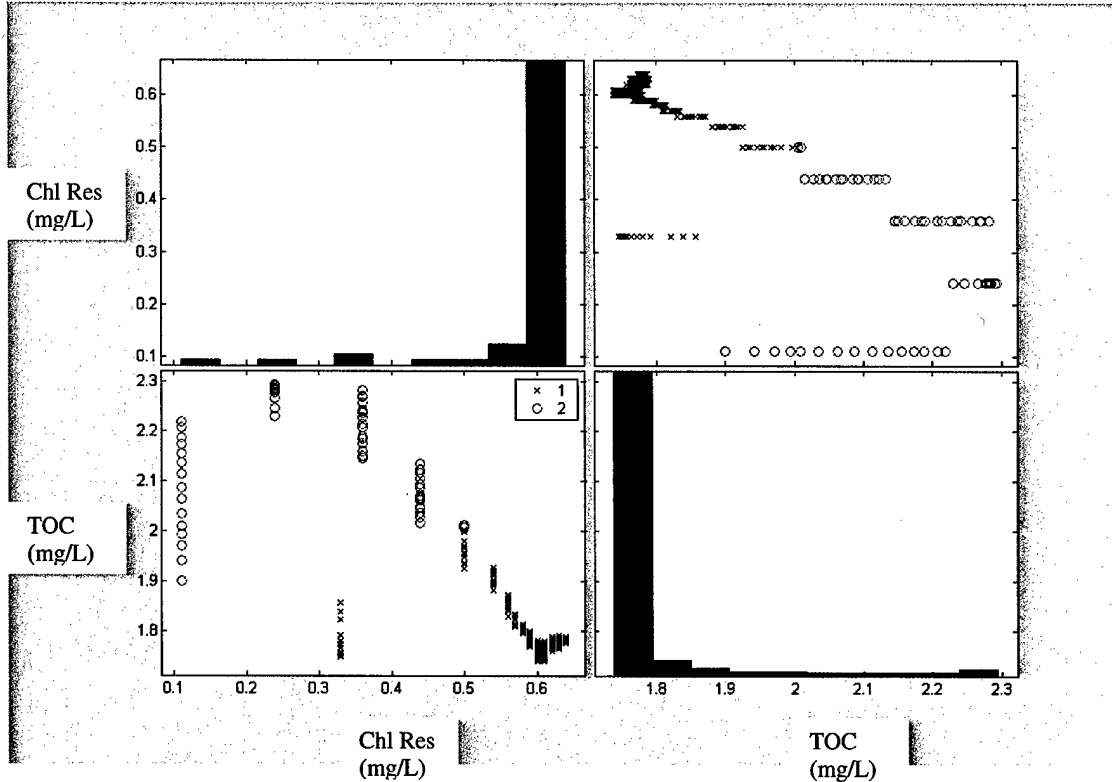
Data were generated from experiments conducted with the bench scale distribution system and the four chemical contaminants that have been previously mentioned. The on-line monitors used with the bench scale distribution system automatically logged the data real-time into a Microsoft Excel spreadsheet. The data was already specific to experiments based on the contaminant and concentration of the contaminant used.

Matlab v6.5 was used to generate the bivariate plots and to classify the water quality data into two classes: one class that represented baseline conditions, and one that represented an anomalous event, such as injection of the contaminant into the distribution system. The code that was used to conduct the data analysis is provided in Appendix E. The Microsoft Excel spreadsheets were converted into text files before being used in Matlab.

Figures 5-2 and 5-3 use aldicarb (10 mg/L) instrument response data to provide a relative example of clustering. Figure 5-2 shows the chlorine residual versus the TOC plot before clustering. Figure 5-3 shows the result after k-means separated the same data points into two clusters.



**Figure 5-2** Raw instrument-response data before clustering



**Figure 5-3** Data from Figure 5-2 assigned to clusters

The top right chart in Figure 5-3 is very similar to Figure 5-2. As can be seen, a clear distinction was made between data points by the cluster assignment -- blue or green. A closer look reveals that the cluster assignment of green indicates water quality with high TOC and low chlorine residual. For aldicarb, these are expected instrument responses. Aldicarb contains a large amount of organic carbon, and has a high chlorine demand. A cluster assignment of blue indicates 'normal' or baseline water quality. Figure 5-3 also displays the histograms of the two variables. What's interesting about the histograms is the large amount of data points that are in the high chlorine residual and low TOC areas. Again, this would be expected under 'normal' water quality conditions-- a relatively high chlorine residual, and a relatively low TOC. It is easy in this case to

appreciate the classification between good water quality (blue) and poor water quality (green).

After this approach was applied to cluster the contaminant instrument response data, the cluster assignments were loaded into Excel. This enabled the precise determination of *when* the clusters were assigned. The goal then would be to determine which approach identified a contamination event first. Would the peak instrument response for a given parameter be the first indication of a contamination event, an instrument response that was above or below three standard deviations from the mean, or the change in cluster assignment from baseline?

### **5.3 Results/Discussion**

Figures 5-4 through 5-7 display bivariate plots of the on-line instrument response after specified contaminants and concentrations were injected into the bench scale distribution system. The blue "x's" in the plots display the instrument response under baseline conditions, or the first 100 minutes of run time. The green "o's" represent the instrument response after  $t=100$  minutes, or after the contaminant was injected into the system. As the contaminant slug passes through the system and eventually the on-line instrumentation, it would be expected that there would be an instrument response shortly after the contaminant was injected, and then the water quality parameters would return to baseline conditions after a period of time. Because of this, it should be apparent that there is overlap between the o's and x's, likely representing the return of the water quality to baseline conditions well after contaminant injection.

What these plots demonstrate is the natural, qualitative clustering of baseline conditions and contaminant conditions. In Figure 5-4, this is highlighted by the increase

in turbidity, TOC, and pH. Another interesting point to note is the scale of the plots. The scales are automatically generated in Matlab, consistent with the data. As can be seen, the clustering is separated by very small changes in water quality. This is encouraging, as it is always the goal to detect contamination events at the lowest possible concentration or as quickly as possible. The potential down-side to this sensitivity is the ability to yield false positives.

Similarly, Figure 5.5 highlights the chlorine demand often associated with aldicarb. Figure 5-6 shows an increase in pH, conductivity, and turbidity for sodium arsenate. Figure 5-7 displays an increase in pH, conductivity, and turbidity, while showing a decrease in chlorine residual for sodium cyanide.

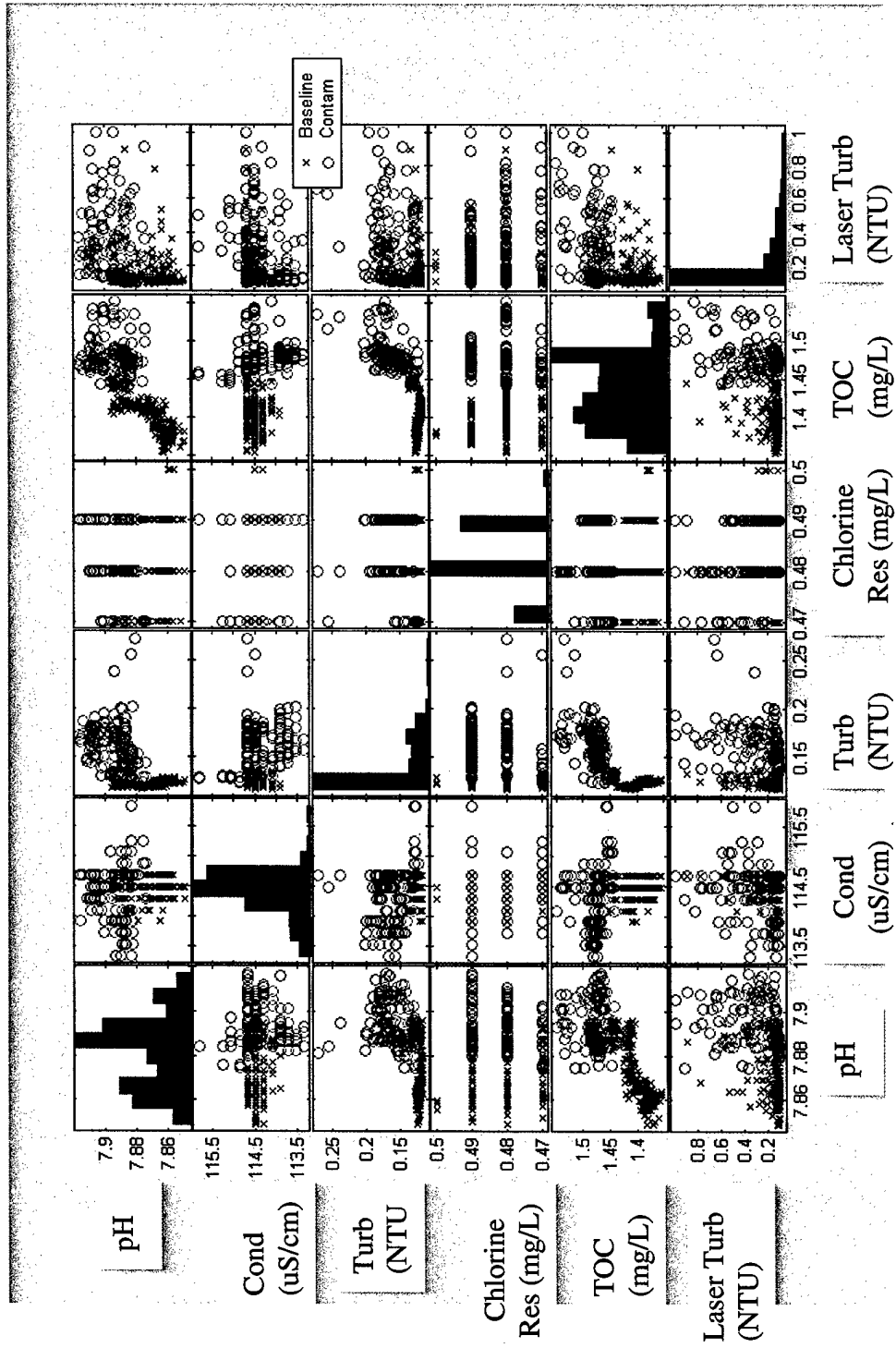


Figure 5-4 Bivariate plot of instrument response after 3 mg/L of sodium fluoroacetate was added to tap water

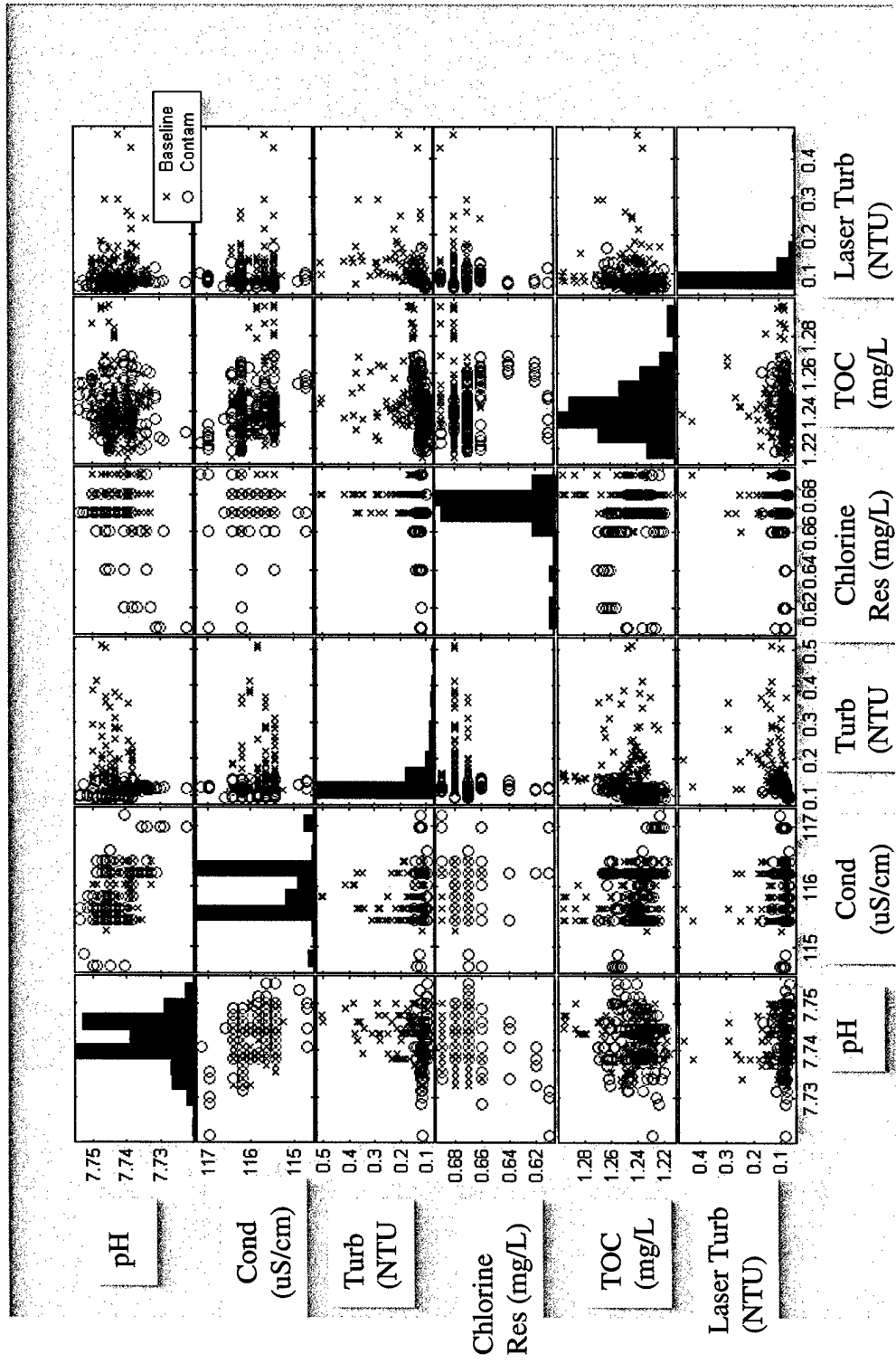


Figure 5-5 Bivariate plot of instrument response after 1 mg/L of aldicarb was added to tap water

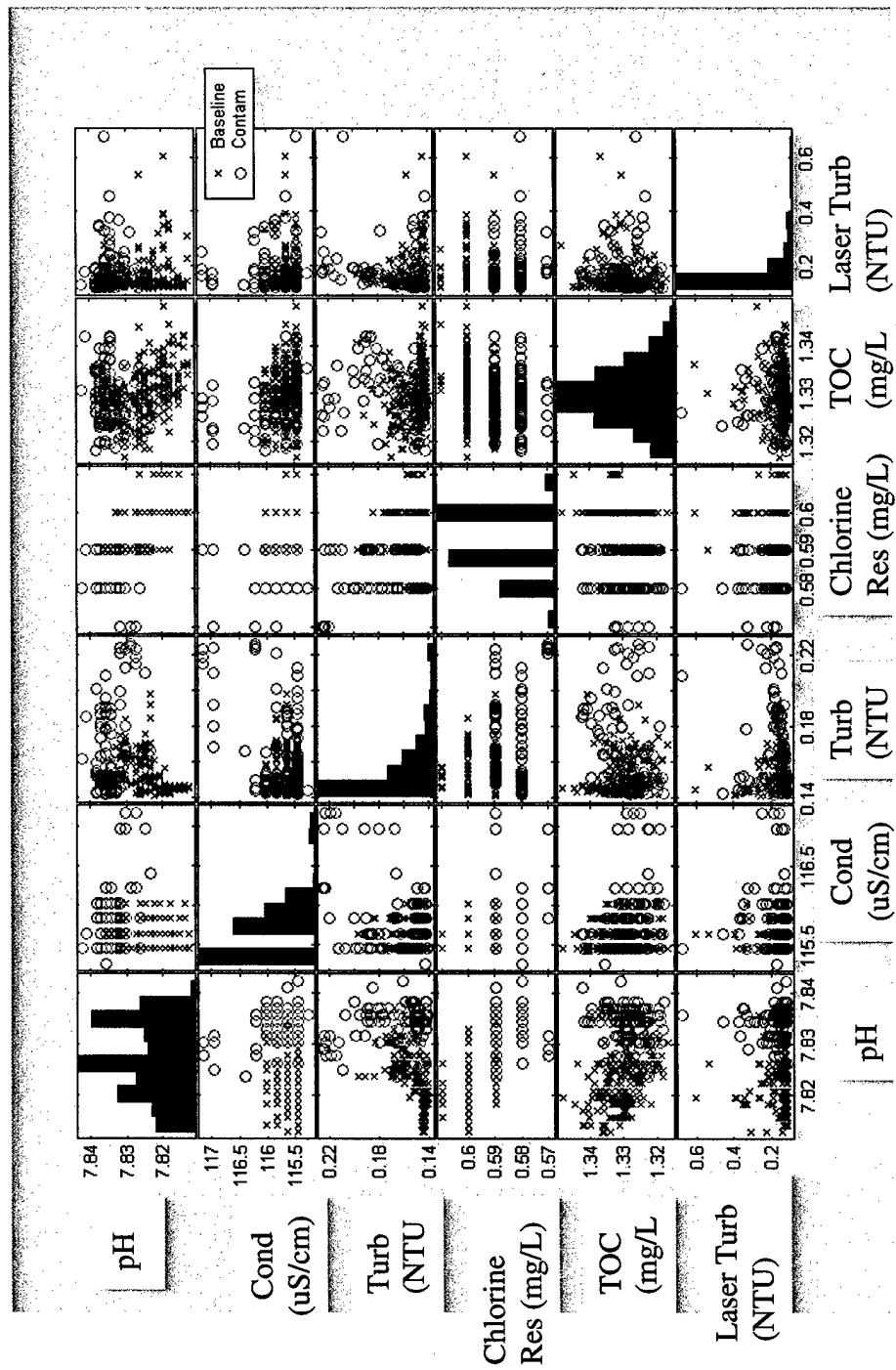


Figure 5-6 Bivariate plot of instrument response after 15 mg/L of sodium arsenate was added to tap water

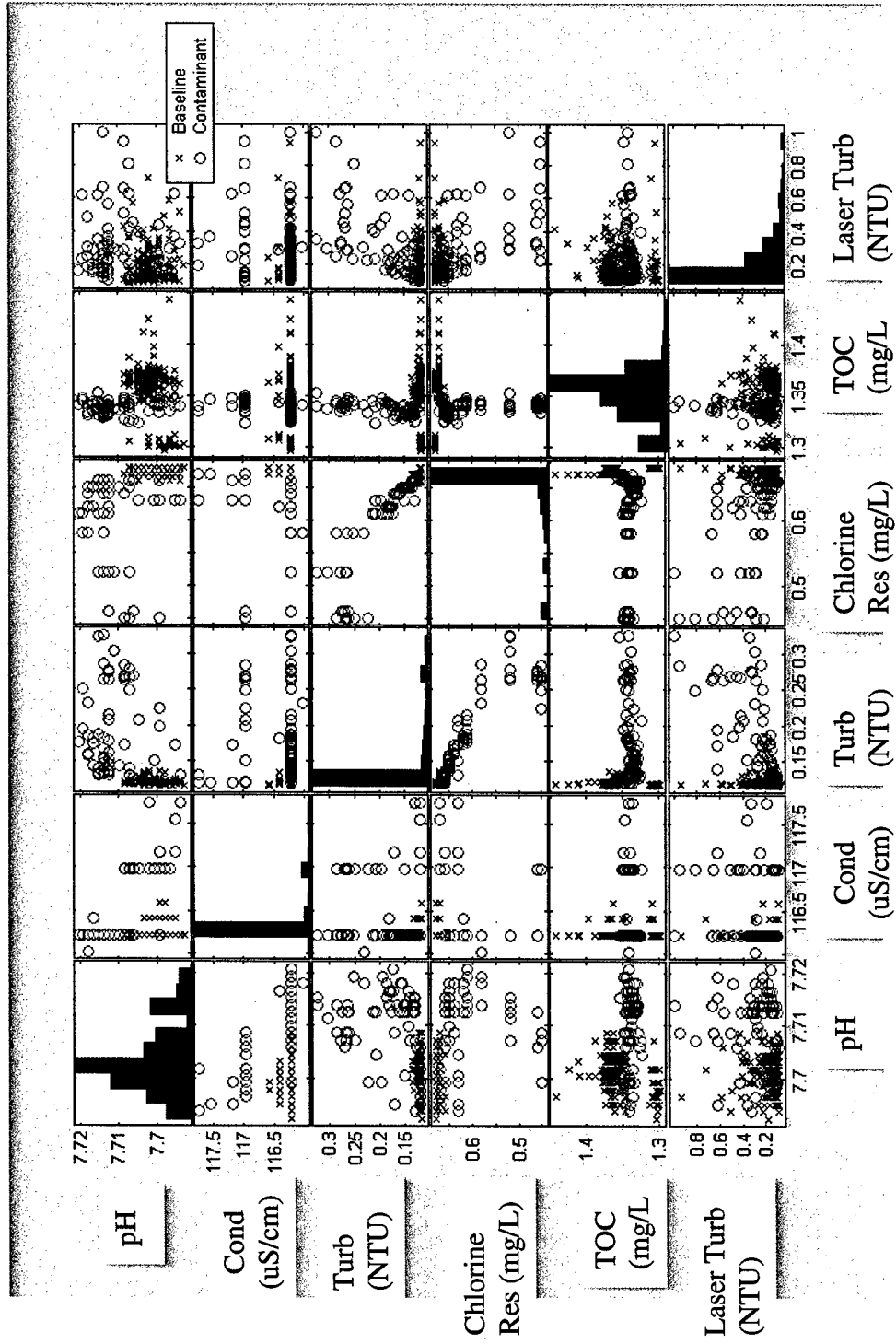


Figure 5-7 Bivariate plot of instrument response after 1 mg/L of sodium cyanide was added to tap water

Table 4-4 provided limits of detection for the four chemical contaminants used in this effort relative to instrument response and equipment accuracy. For the analysis in this chapter, equipment accuracy will not be considered, as the k-means algorithm is simply looking at the instrument responses provided and assigning them into appropriate clusters. This ensured that water quality parameters that are selected to compare the k-means time to detection are indeed the most sensitive to the contaminants used. Given this, Table 5-1 provides similar limits of detection without consideration of equipment accuracy.

**Table 5-1** Limits of detection for contaminants per water quality surrogate without consideration of equipment accuracy

Contaminant	Chlorine Residual	Conductivity	pH	TOC	Turbidity	Laser Turb
Sodium Arsenate (mg/L)	50	<15	>100	>100	<15	<15
Sodium Cyanide (mg/L)	<0.5	<0.5	1	5	<0.5	1
Sodium Fluoroacetate (mg/L)	5	<3	<3	<3	3	3
Aldicarb (mg/L)	<1	10	1	3	3	3

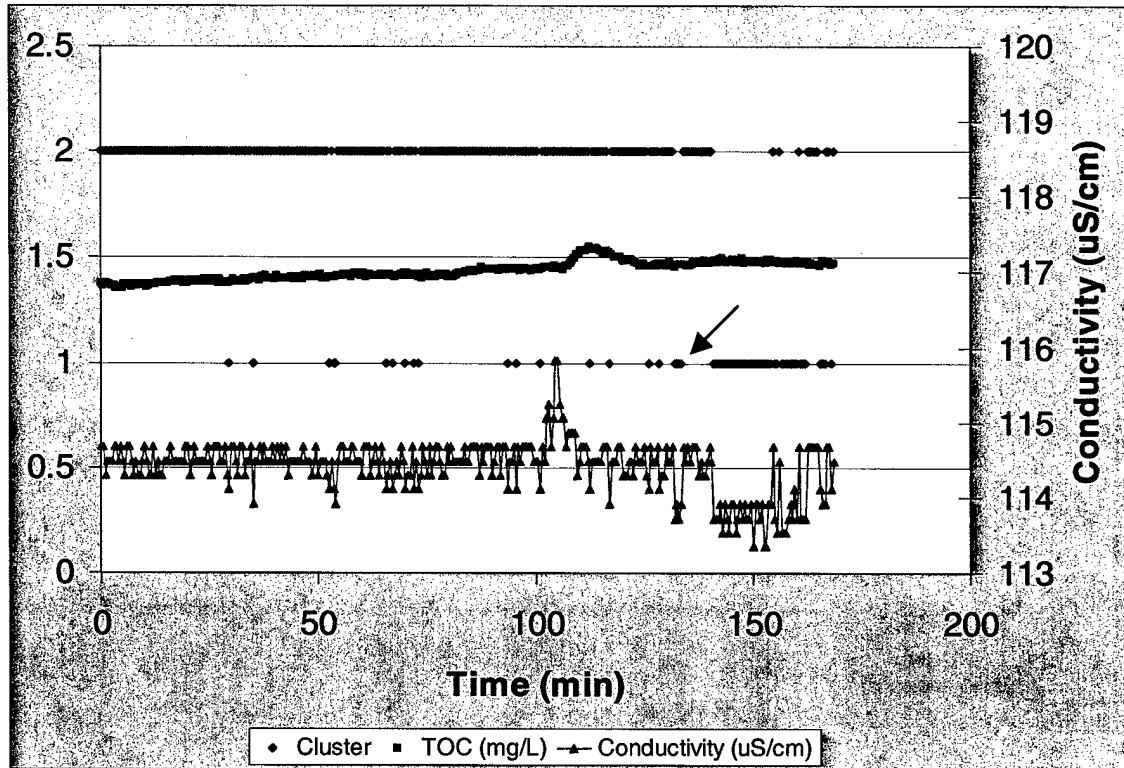
Based on the highlighted values in Table 5-1, comparisons were made for sodium arsenate conductivity, sodium cyanide turbidity, sodium fluoroacetate TOC, and aldicarb chlorine residual to distinguish the difference between detection times for peak responses, greater than three-sigma response from the mean, and the point after injection at which the contamination cluster is changed. The k-means algorithm seems sensitive to changes in conductivity, in some cases more sensitive to conductivity than Table 5-1 would suggest. Because of this, conductivity will be displayed on each chart and comparisons will be made between the 'sensitive' parameter as determined in Table 5-1 and conductivity.

Figures 5-8 through 5-11 display the selected cluster assignment and instrument response, versus time. These figures will help appreciate the impact that cluster analysis may have with regard to detection time of a contamination event. It is anticipated that with the use of all six water quality parameters to determine a cluster assignment, that the cluster analysis will be quicker at determining a contamination event than the univariate analysis discussed in chapter 4.

Based on observations from the clustering of the baseline data ( $t < 100$  minutes), a rule for determining a successful cluster event will be established as having more than three successive cluster points. This is critical in reducing false positives and providing a precise time to determine time of detection. This becomes readily apparent in Figure 5-8 where there are blips that indicate a cluster change *before* a contaminant is introduced into the system. In addition, the clusters are assigned randomly, so cluster one or cluster two will not always represent 'normal' or anomalous conditions. The easiest way to make this distinction is to look at which cluster the earliest data ( $t < 100$  minutes) is assigned to. This cluster will represent baseline conditions, and hence, 'normal' water quality.

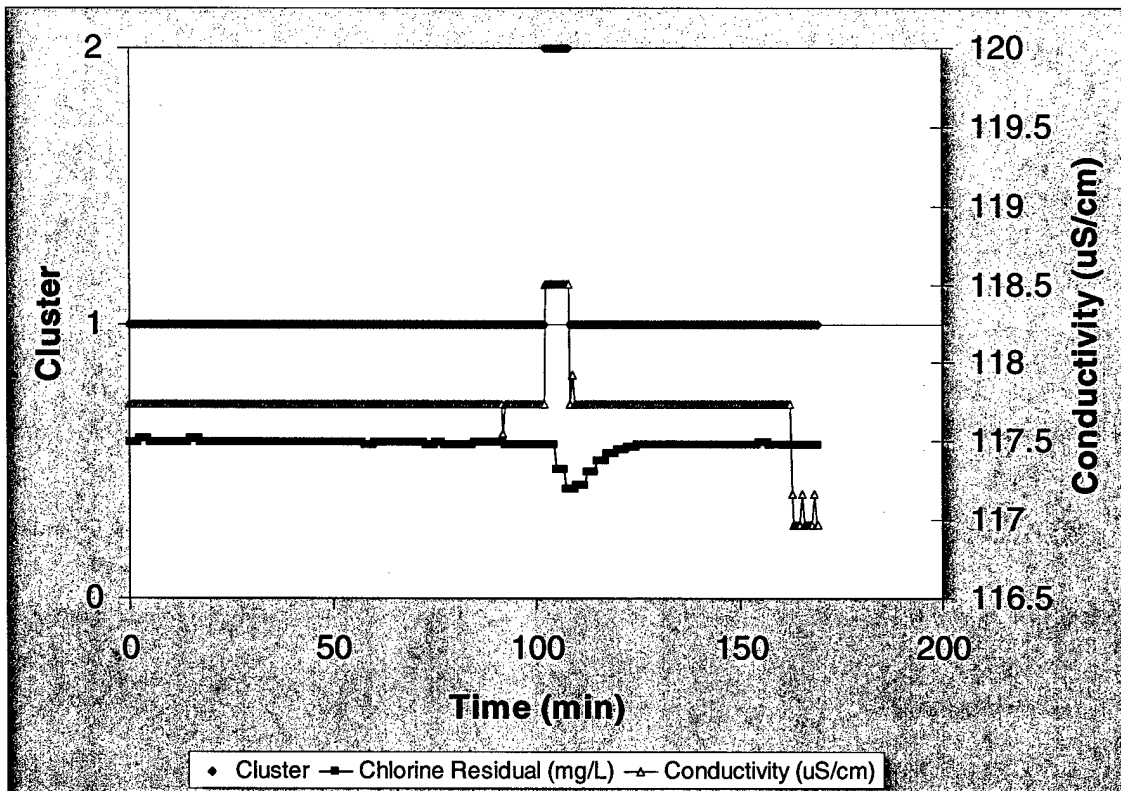
Figure 5-8 demonstrates that clustering will not always be more timely in detecting a contamination event than univariate analysis. As can be seen, a significant shift in cluster assignment does not occur until  $t = 132$  minutes, well after the TOC peak instrument response of 112.5 minutes, and even further from the  $\bar{x}$  plus three-sigma TOC response at 108.5 minutes. The conductivity instrument response is added to the chart to show how responsive the cluster analysis is to conductivity in and of itself. It is

interesting to note that the cluster analysis does not respond to the short lived conductivity spike.



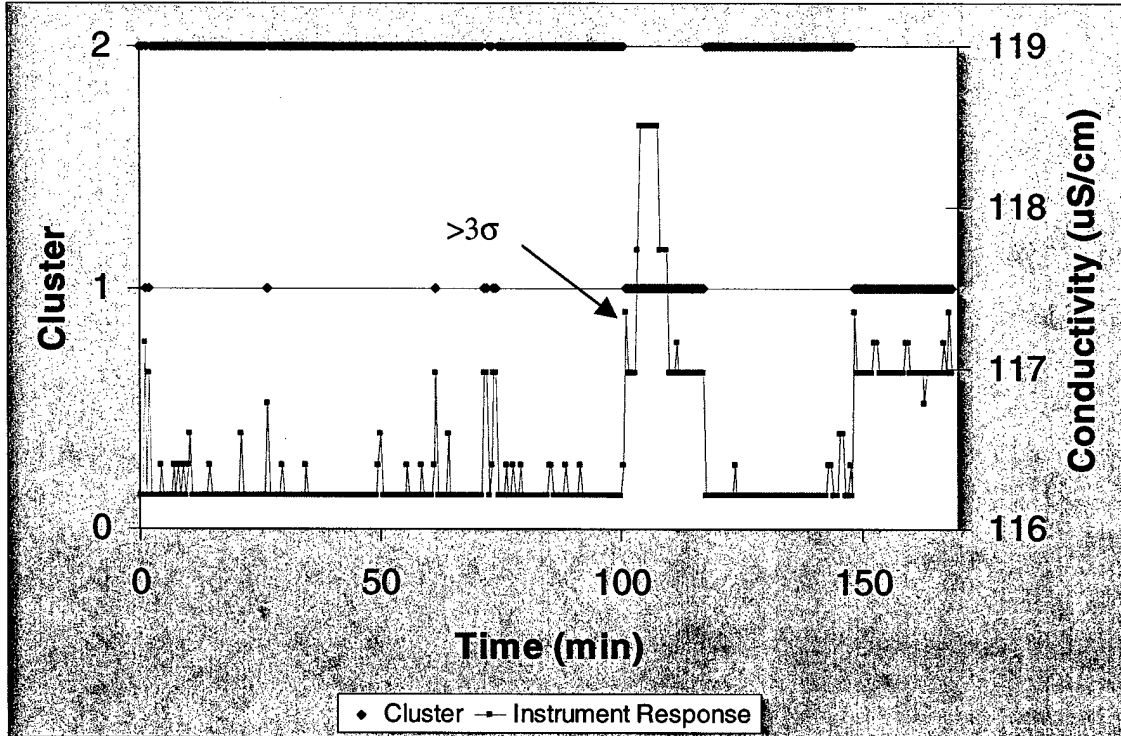
**Figure 5-8** Instrument response and cluster assignment after 3 mg/L of sodium fluoroacetate was added to tap water

Figure 5-9 is more encouraging. As can be seen, the changes in water quality considering all six parameters is clustered as an anomaly just before the chlorine residual instrument response is outside of  $\bar{x}$  minus three-sigma and the peak instrument response. As mentioned previously, the cluster seems to change consistent (and before chlorine residual) with a significant change in conductivity.



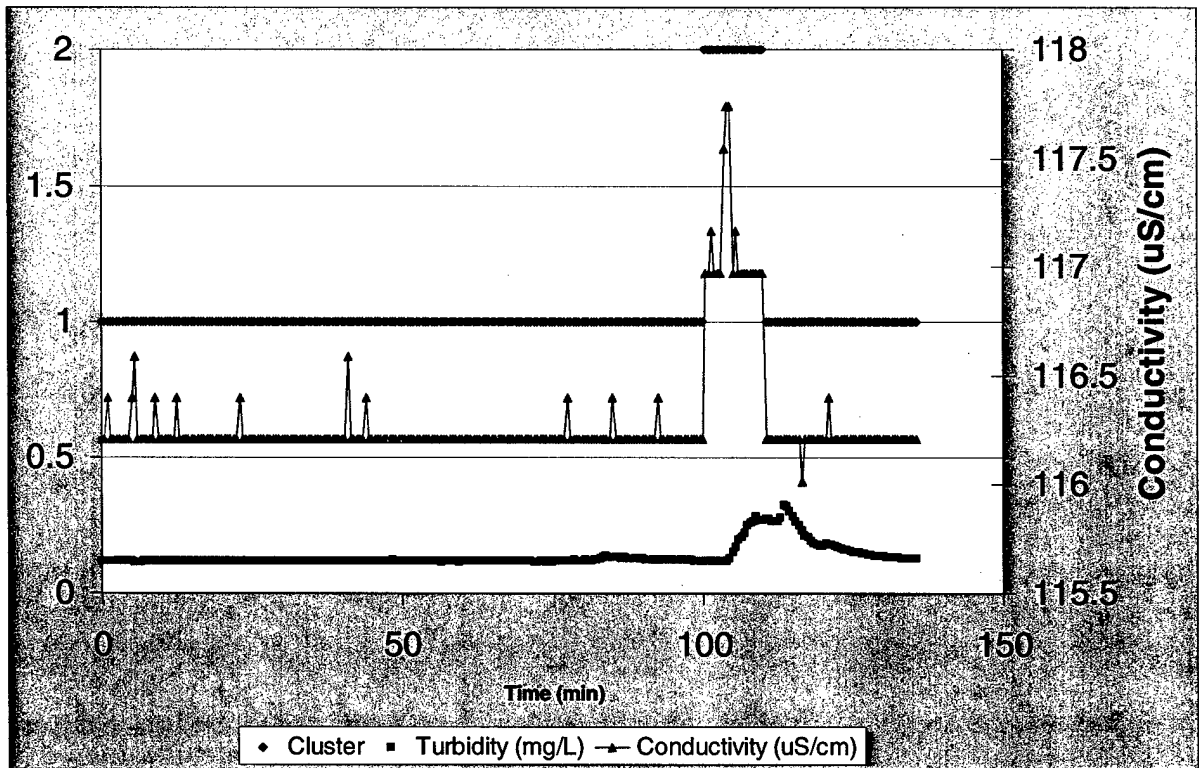
**Figure 5-9** Instrument response and cluster assignment after 3 mg/L of aldicarb was added to tap water

Figure 5-10 is interesting, as the changes in water quality considering all six parameters is clustered as an anomaly at the same time that the conductivity instrument response is outside of  $\bar{x}$  plus three-sigma, and before the peak instrument response.



**Figure 5-10** Instrument response and cluster assignment after 25 mg/L of sodium arsenate was added to tap water

Figure 5-11 is the most encouraging. The changes in water quality considering all six parameters is clustered as an anomaly ten minutes before the turbidity instrument response is outside of  $\bar{x}$  plus three-sigma, and nineteen minutes before the peak turbidity instrument response, but again, at the same time that there is a significant conductivity response. To try and appreciate why sodium fluoroacetate did so poorly and why sodium cyanide did so well with cluster analysis, a comparison was made between the peak instrument responses minus the baseline averages for all variables for sodium fluoroacetate (3 mg/L) and sodium cyanide (1mg/L). These results are provided in Table 5-2.



**Figure 5-11** Instrument response and cluster assignment after 1 mg/L of sodium cyanide was added to tap water

**Table 5-2** Comparison of peak minus baseline average instrument response for most and least sensitive contaminant to cluster analysis

Contaminant	Cluster Analysis	pH	Conductivity (uS/cm)	Turbidity (NTU)	Chlorine Residual (mg/L)	TOC (mg/L)	Laser Turbidity (NTU)
1080 (3 mg/L)	Not Responsive	0.044	1.331	0.148	-0.011	0.146	0.840
NaCN (1 mg/L)	Responsive	0.019	1.517	0.206	-0.223	-0.004	0.820
Ratio (NaCN/1080)		0.440	1.139	1.396	19.557	-0.029	0.976

Table 5-2 conflicts with the previous discussions that conductivity may be the only parameter that the cluster analysis is responding to. This was mentioned briefly when it was apparent that the conductivity spike in Figure 5-8 did not elicit a response in the cluster analysis. In the comparison, the instrument responses are similar when looking at conductivity, yet sodium fluoroacetate did not cluster well. It is interesting to note that when the cluster analysis did finally respond to sodium fluoroacetate, it was in conjunction with a considerable and sustained conductivity drop. What Table 5-2 does imply is that with a single large response, e.g. chlorine residual in the case of sodium cyanide, and other significant instrument responses like turbidity, the clustering performs well. This should be expected, as increased concentrations of contaminants will generate increased responses, and the clustering should clearly identify a shift in water quality.

Table 5-3 summarizes additional parameters that were highlighted in Table 5-1 and offers a comparison between detection times. The univariate analysis detection times are depicted as  $t_{\text{peak}}$  and  $t_{>\text{avg} + 3\sigma}$  while the multivariate analysis is depicted as  $t_{\text{cluster}}$ . The cluster analysis detected a contamination event at least as soon as or quicker than the univariate analysis in ten of the sixteen cases, or over 62% of the time. Ineffective cluster analysis was determined when the k-means algorithm did not cluster the data after injection of a contaminant for more than three consecutive points.

**Table 5-3 Comparison of detection times for univariate versus multivariate analysis**

Contaminant	Concentration (mg/L)	Univariate		Multivariate	Comparison	
		$t_{>avg + 3\sigma}$ (min)	$t_{peak}$ (min) Parameter from table 5-1		$t_{cluster}$ (min)	$t_{cluster} - peak$ (min)
Sodium Arsenate	15	104.0	107.0	102.5	-4.5	-1.5
	25	113.0	114.5	101.0	-13.5	-12.0
	50	107.0	111.0	Ineffective	NA	NA
	100	103.5	105.5	102.5	-3.0	-1.0
Sodium Cyanide	0.5	106.5	109.0	Ineffective	NA	NA
	1	104.5	107.0	100.5	-6.5	-4.0
	3	107.0	107.0	103.0	-4.0	-4.0
	5	108.5	111.0	107.0	-4.0	-1.5
	10	109.0	114.0	105.0	-9.0	-4.0
Sodium Fluoroacetate	3	133.5	134.0	141.0	7.0	7.5
	5	101.0	103.0	Ineffective	NA	NA
	10	114.0	114.0	103.5	-10.5	-10.5
Aldicarb	1	107.5	107.5	121.0	13.5	13.5
	3	105.0	107.5	102.5	-5.0	-2.5
	5	107.0	109.5	104.0	-5.5	-3.0
	10	109.0	111.5	111.5	0.0	2.5

Another consideration when conducting cluster analysis includes the discrimination between the cluster means. A large table is included in Appendix E that provides the cluster means per water quality parameter relative to contaminant concentration.

#### **5.4 Conclusions**

The bivariate plots demonstrated the potential that cluster analysis may offer by displaying the natural separation of data that occurs when a contaminant is introduced into the bench scale distribution system. This separation of data, or classification, was quantifiable when the data was clustered, providing a timeline to compare the detection of contaminants by multivariate analysis (clustering) to univariate analysis (single parameter).

Table 5-3 provided a comparison of the detection time, displaying that in over 62% of cases looked at, the cluster analysis detected a contamination event as quickly as, or faster than, the univariate approach. This is likely due to the impact that six variables being looked at simultaneously will have on the ability to detect a contamination event, versus a single variable as in univariate analysis. This was demonstrated by the success of the clustering of sodium cyanide contamination. Sodium cyanide effects most of the water quality parameters significantly, and as such, was clustered well. The cluster analysis was not as successful at the lower contaminant concentrations, either not effectively discriminating between post-injection water quality and 'normal' conditions, or doing so slower than univariate analysis.

The data that was input into the k-means algorithm was raw data. The data was not pre-processed, meaning that it was not normalized or scaled. By not pre-processing

the data, capability may have been lost. In addition, the determination that conductivity played such a large role may be more a factor of the lack of pre-processing than conductivity itself. This is likely the case because conductivity values were significantly larger than other parameters, and the variance and range were also significantly larger.

There are several different algorithms that can perform classification or cluster analysis. Perhaps other algorithms would perform better. Based on the work in this chapter, the most robust analysis system would consider both univariate and cluster analysis to detect a contamination event as quickly as possible and at the lowest concentration.

## CHAPTER 6 SECONDARY INSTRUMENT RESPONSE FROM BIOFILMS

---

### UTILIZING BIOFILMS IN DRINKING WATER DISTRIBUTION SYSTEMS TO REDUCE LIMITS OF DETECTION FOR CHEMICAL CONTAMINANTS

---

#### 6.1 *Introduction*

Rapid detection of chemical contamination in the distribution system is essential to providing early warning to protect public health. Using water quality surrogates to detect a contamination event offers the advantage of casting a wider net to catch an unlimited quantity of contaminants. The concern then is focused on the ability of these surrogates to detect chemical contaminants at a concentration low enough to prevent serious illness. One approach to increasing the signal to noise ratio of the contaminant-instrument response may lie in taking advantage of biofilms that are a natural part of drinking water distribution systems. The introduction of toxic chemicals to the distribution system may disrupt the biofilm, causing sloughing of biomass, which will then be detected as a significant increase in turbidity.

Direct contaminant-instrument response may be able to detect most contaminants in the distribution system before a negative health outcome is realized in the affected community. This was demonstrated in Chapter 4. The concern is with the word most. The chemicals that were studied include aldicarb, sodium arsenate, sodium cyanide, and sodium fluoroacetate. They are all very toxic and soluble, and may induce secondary effects in the distribution system, such as disrupting or causing established biofilm to slough off. Quantifying the indirect contaminant-instrument response in the distribution

system as an anticipated increase in turbidity and determining the log-removal of cells from PVC coupons was the objective of this study, with the goal being to reduce the limit of detection for chemical contaminants.

Biofilms exist in all distribution systems, are recognized as part of the normal aquatic system, and are introduced into the distribution system by well-treated, but non-sterile water (US Environmental Protection Agency, 1992). Living microorganisms and nutrients enter drinking water distribution systems from failures at treatment plants, pipe breaks or leaks, backflow, and cross-connections (Khan, et al., 2001). In addition, microbiological contamination can occur via uncovered storage tanks, and water main installation and repair (Kirmeyer et al., 2001). Even water systems that have excellent sanitary practices for main breaks and repair still have contaminant entry into the distribution system (LeChevallier, 1999).

Microbial cells from the contamination events mentioned above attach to pipe walls and multiply to form a biofilm (USEPA, 1992). The roughness of the pipe wall, usually a factor of the pipe material and condition, is a key factor that influences both attachment and detachment of biofilm. Volk and LeChevallier (1999) state that pipe material may have more influence on biofilm growth potential than the level of organic matter in the system.

The USEPA describes biofilms as always being in a state of flux, including the processes of attachment, metabolism, growth, product formation, and lastly detachment (or sloughing) from the pipe wall. Percival et al. (2000) classify detachment as erosion of single cells due to shear stresses, sloughing that occurs with cell clusters usually in older

biofilms, abrasion by collision of solid particles, human intervention (e.g. the addition of oxidants to drinking water), and predator grazing.

This research used rotating annular bioreactors (RABs) to grow a biofilm representative of the local distribution system. Rotating annular bioreactors have been used extensively in pursuit of understanding biofilm growth in drinking water systems (Butterfield et al., 2002; Lawrence et al., 2000; Ollos et al., 2003, Fleming et al., 2000). Advantages of RABs include the capability to simulate factors that influence biofilm growth in drinking water systems, including pipe material and size, near constant shear stress on the coupon surfaces, and a well-mixed bulk phase under turbulent flow conditions (Lawrence et al., 2000). Other factors that are key to simulate biofilm growth conditions are temperature and chlorine residual.

Water temperature is perhaps the most important rate controlling factor regulating microbial growth (LeChevallier, 1989). In water temperatures of 15 deg C and higher, most investigators have found significant microbial activity (Howard, 1940; Rizet et al., 1982; Fransolet et al., 1985; Donlan and Pipes, 1988; LeChevallier et al., 1990). Ollos et al. (2003) showed that as temperature increased from 8 deg C to 17 deg C, biofilm growth was more affected than at temperatures of 17-26 deg C, and that generally, steady-state bacterial numbers increase with increasing temperature. The USEPA reports that in the New Haven, Connecticut water system, a two year study showed increases in microbial growth up to and including the highest temperature range of 19.2 deg C +/- 3.1 (USEPA, 1992). This emphasis on temperature relative to biofilm growth is significant, as the drinking water used in this research has a maximum expected finished water

temperature reported as approximately 18 deg C (Fort Collins Utilities Annual Operating Report, 2001).

After experimental controls were completed, and the biofilm was established in the RAB, the biofilm was exposed to threat chemical contaminants at varying concentrations. Baseline turbidity conditions were established for tap water, the water within the reactor, and tap water with the addition of the contaminant. The reactor was drained, then immediately refilled with the contaminant solution. Turbidity measurements of the reactor water were taken at specified time intervals, and then PVC coupons were pulled from the reactor randomly to quantify the cells on the coupon. After quantifying the cells on the coupon using fluorescence microscopy, cell counts were compared between those that were and were not exposed to the contaminant, and a log-removal was determined. The cell removal studies were key to correlating the increase in turbidity in the reactor with biofilm sloughing.

## **6.2 *Materials and Methods***

**Microbiological simulation of the distribution system.** Drinking water distribution systems can not be characterized or simulated thoroughly without consideration of the microbiological factors, particularly biofilms. The BioSurface Technologies 1120LJ rotating annular bioreactors used in this study are flow through, continuous stirred tank reactors. Twenty PVC coupons were mounted on the rotating drum, and acclimated to distribution system conditions for at least five weeks. It has been established that 4-6 weeks is a reasonable time in which to grow a steady-state biofilm in a rotating annular reactor (Camper 1995, Butterfield et al. 2002). The bioreactors were covered during the acclimation period to prevent the growth of phototrophic cells that would not normally be

found in a drinking water distribution system. During the acclimation period, the bioreactors rotated at 52 revolutions per minute, simulating an average pipe diameter of 10", an average water velocity of 1 ft/sec, and a Hazen-Williams coefficient of 140 that is typically used for estimating pipe roughness in PVC pipe (Biosurface Technologies Corporation, 1998). The average chlorine residual in the distribution system water was 0.5 mg/L, and the pH ranged from 7.8-8.0. To eliminate the seasonal water temperature impacts in Colorado on biofilm growth, a Neslab RTE-4 heat-exchanger was used in the cooler months to bring the reactor temperature between 12-18 degrees Celsius. The heat exchanger pumped hot water into and out of the external jacket of the reactor without coming into contact with the reactor water or coupons. This was made possible with the utilization of o-rings that sealed both the reactor annular space and the temperature controlling jacketed space.

Steady state cell counts for biofilm grown in the rotating annular bioreactor should be on the order of  $10^6$  cells per coupon (Biosurface Technologies Corporation, 1998). Table 6-1 provides a summary of total cells counts per coupon and square-inch that correlate to the cell counts seen per microscopic field. Cell counts per field ranged from zero to 4.44 during the experiments.

**Table 6-1 Cell counts**

Cell Counts per Microscopic Field	Cell Counts per Coupon	Cell Counts per in <sup>2</sup>
0	0	0
1	398,247	108,455
2	796,494	216,910
3	1,194,741	325,365
4	1,592,988	433,820
5	1,991,235	542,275

**Measurement of contaminant-instrument response.** After the biofilm was established in the RAB for a minimum of 5-weeks, turbidity measurements were taken for tap water and for reactor water. The reactor was drained and quickly re-filled with tap water, and turbidity measurements were taken from the reactor at after one, eight, and forty-eight minutes. A Hach 2100 AN turbidimeter was used to measure turbidity in the water samples. This was completed before the experiments were conducted with the contaminants. This ensured that any increase in turbidity was indeed due to toxicity induced sloughing from the contaminants and not the experimental procedure.

For the contaminant experiments, baseline turbidity conditions were established for tap water, reactor water, and tap water that included the contaminant. One coupon was pulled out of the reactor to establish a baseline cell count. At this point, the reactor was drained, and the contaminant solution was immediately added to the reactor. Reactor water turbidity measurements and the removal of one coupon occurred after the contaminant solution was in the reactor for one, eight, and forty-eight minutes each. The turbidity measurements were recorded, and the difference between the baseline turbidity measurements and the contaminant-in-reactor turbidity measurements were determined. This provided the first indication if toxicity induced sloughing would increase turbidity measurements in a distribution system.

**Determining log-removal of cells.** In order to maintain a significant quantity of coupons in the reactor, a statistical study was conducted to determine how representative one coupon would be of all coupons in the reactor. This ensured that the one coupon that was pulled out of the reactor at each time increment was representative of cell counts that would be obtained on other coupons in the reactor, and eliminated the need to pull out

multiple coupons per time increment, thereby maintaining a similar quantity of biomass in the reactor that would be available to be sloughed-off.

Eight coupons were pulled out of a reactor that was acclimated to tap water for at least five weeks. Each coupon was scraped and the cells counted as described in the next paragraph. The cell count data was determined to be normally distributed using the Anderson-Darling Normality Test in Minitab, with a p-value equal to 0.330, well above the criteria value of 0.05. A 95% confidence interval (CI) was calculated based on the results of the cell counts on the eight coupons, and with the use of the equation below.

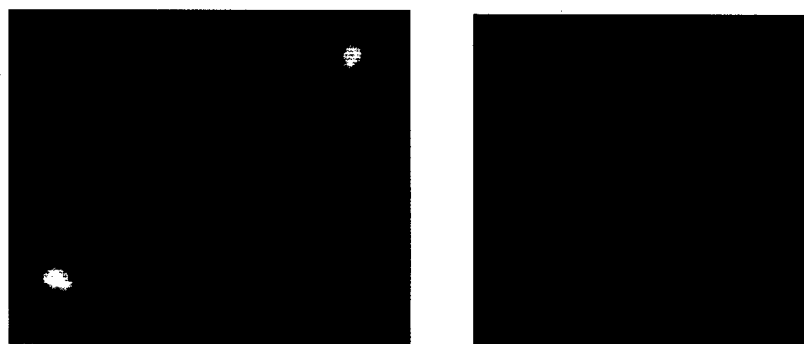
$$\bar{x} - t_{1-\alpha/2, n-1} s / \sqrt{n} \leq \mu \leq \bar{x} + t_{1-\alpha/2, n-1} s / \sqrt{n}$$

Five of the eight coupon cell counts were within the confidence interval. This implies that there is a 95% confidence that the confidence interval should include the true mean of the cell counts on 62% of the coupons, providing some assurance of homogeneity, and allowing the use of only one coupon per time increment to be pulled.

Of the three that were not in the confidence interval, two were above the CI (one just barely), and one was below the CI. The two that were farthest from the mean fit the tail ends of a normal distribution precisely.

Once the coupons were pulled from the bioreactor, they were placed in 75 mL test tubes (20cm x 2cm) and refrigerated. Biofilm was removed from the coupons by scraping. Only one side of the coupon was scraped, and used to obtain a cell count. This is because only the outside surface of the coupon was exposed to the shear stresses in the reactor. Coupons were scraped into 3 mL of tap water that was filtered through a 0.20  $\mu\text{m}$  syringe filter. The filtering step prevented additional bacteria that may have been

present in the tap water from entering solution. This solution was then transferred to a 50 mL polypropylene conical tube to facilitate pipetting 1 mL of solution into a 1.7 mL polypropylene flat top low retention tube. Three microliters of the combined two stains that make up a Molecular Probes LIVE/DEAD® BacLight™ 7012 bacterial viability kit were added to the biofilm containing solution. This solution was then vortexed to ensure mixing, slides were prepared, and the cells were counted using fluorescence microscopy. Live cells fluoresced green, dead cells fluoresced red as indicated in Figure 6-1.



**Figure 6-1** Fluorescing of live and dead cells under UV light

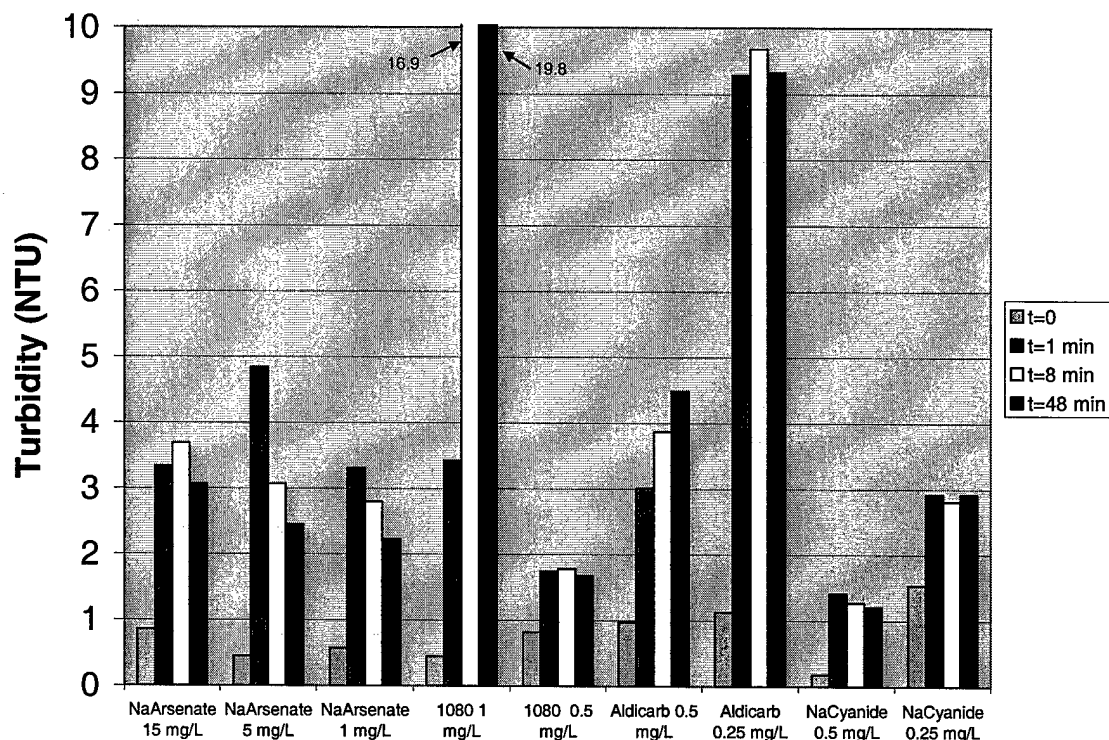
To determine the log removal of cells from the coupons ( $y$ ), the negative log was taken of the live cell count after being exposed to the contaminant in the reactor for  $t=1$ , 8, and 48 minutes ( $c_t$ ), divided by the live cell count ( $c_0$ ) before exposure to the contaminant.

$$y = -\log (c_t/c_0)$$

### **6.3 Results and Discussion**

**Turbidity Response.** Figure 6-2 displays the increase in turbidity after the contaminants were added to the bioreactor at different concentrations. As displayed, the turbidity increased significantly and quickly after the contaminants were added. It is expected that

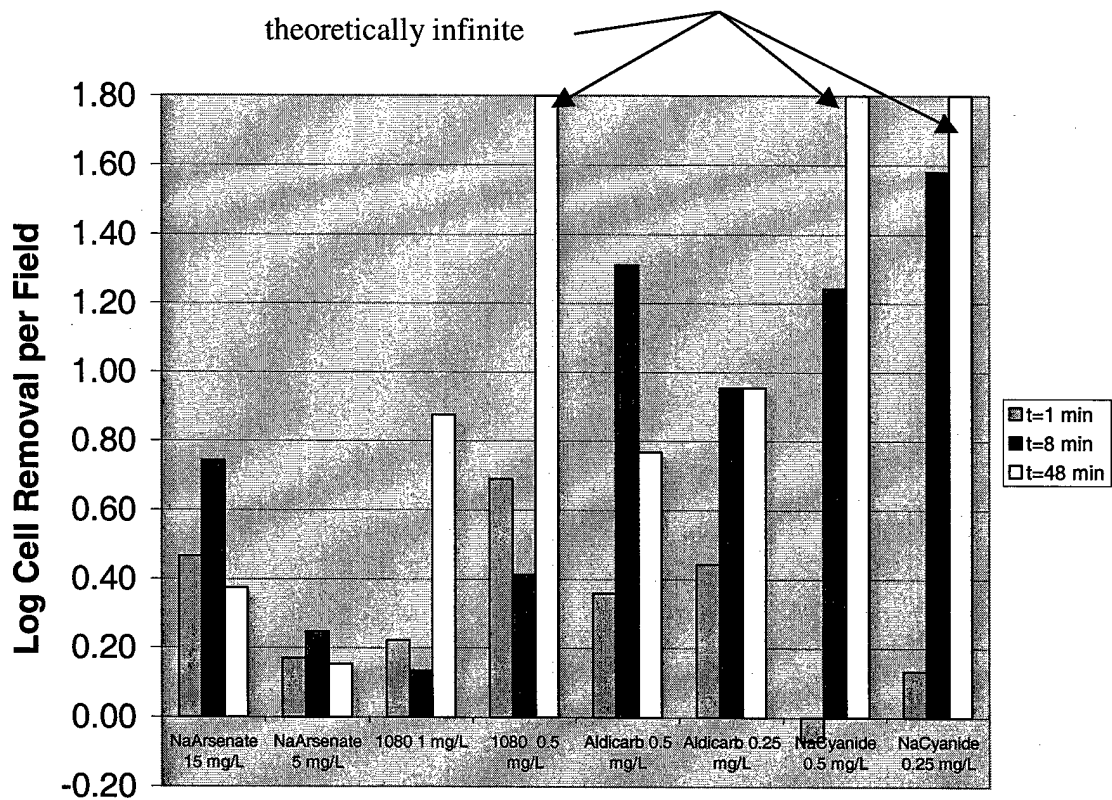
the reactors contained different quantities of biomass on the coupons, hence the differences in instrument response, not necessarily correlated to the concentration of the contaminant. In cases where there is a decrease in turbidity after increased exposure time to the contaminant, it is thought that perhaps there was less biomass available on the coupon after initial exposure to the contaminant to be sloughed off. The next set of experiments included measuring the log removal of cells from the PVC coupons to directly correlate the increase in turbidity with biofilm sloughing.



**Figure 6-2** Turbidity response from biofilm exposure to contaminants

**Correlating increase in turbidity with biofilm sloughing.** To correlate the increased turbidity readings in the reactor water after the coupons were exposed to the

contaminants, the cells on the coupons were quantified before and after exposure to the contaminant. Figure 6-3 displays the log-removal of cells after exposure to the contaminants. The three t=48 minute exposures that had log removal values of 1.8 were actually much larger, as the cell count for those three exposures were reduced to zero, making a log removal calculation impossible, or theoretically infinite, resulting in 100% removal. For comparison purposes, a log removal of one implies 90% removal, and a log removal of 0.5 provides 66% removal. The expected trend would be for an increased log removal of cells as the exposure time and contaminant concentration increases. In cases where this does not happen, consideration should be given to the variance in biomass on the individual coupons, remembering that one coupon was pulled at t=0.



**Figure 6-3** Toxicity induced cell death per contaminant concentration

Figure 6-3 clearly indicates a direct relationship between the concentration of the contaminant and cell removal for sodium arsenate and aldicarb as would be expected. Sodium fluoroacetate (1080) and sodium cyanide do not share a similar relationship between contaminant concentration and log removal rates, likely due to variance in cell counts per coupon. Again, in most cases, the coupons were shown to be homogeneous, but when they weren't, it impacted the results. Another observation included the grouping of cells per microscopic observation. As can be seen in the raw data in the appendix, there were instances when very few cells were detected per field, and then suddenly there would be a field with a "group" of cells, perhaps not separated in solution, that may also have contributed to an unusual result.

Table 6-2 provides the changes in turbidity after contaminant exposure, the changes in cell counts on the coupons, and the calculated log removals, per exposure time to the contaminant. The values that reflect changes are the difference between the value at that time increment, and the baseline value at  $t=0$ . The changes in cell count columns are presented in cells per liter to appreciate the cell density within the bioreactor that may have contributed to the increase in turbidity. Coincidentally, the reactor volume is one-liter.

**Table 6-2** Changes in turbidity, cell counts, and log removal of cells after exposure to contaminant

Contaminant	Concentration (mg/L)	Exposure to contaminant for 1-minute			Exposure to contaminant for 8-minutes			Exposure to contaminant for 48-minutes		
		$\Delta^*$ Turbidity (NTU)	$\Delta$ Cell Count (cells/L)	Log Removal	$\Delta$ Turbidity (NTU)	$\Delta$ Cell Count (cells/L)	Log Removal	$\Delta$ Turbidity (NTU)	$\Delta$ Cell Count (cells/L)	Log Removal
Sodium Arsenate	15	2.48	-23,257,620	0.47	2.83	-28,992,375	0.74	2.21	-20,390,242	0.37
	5	4.39	-9,557,926	0.17	2.62	-12,743,901	0.25	2.00	-8,761,432	0.15
Sodium Fluoroacetate (1080)	1	2.97	-1,911,585	0.22	16.45	-1,274,390	0.13	19.35	-4,141,768	0.88
	0.5	0.92	-11,150,914	0.69	0.96	-8,602,133	0.41	0.86	-14,018,291	1.80
Aldicarb	0.5	2.04	-7,327,743	0.36	2.90	-12,425,304	1.31	3.51	-10,832,316	0.77
	0.25	8.15	-7,327,743	0.44	8.55	-10,195,121	0.95	8.19	-10,195,121	0.95
Sodium Cyanide	0.5	1.24	1,911,585	-0.07	1.09	-10,513,719	1.24	1.03	-11,150,914	1.80
	0.25	1.38	-3,185,975	0.13	1.27	-11,788,109	1.58	1.38	-12,106,706	1.80

\* All changes ( $\Delta$ ) reflect the difference in turbidity and cell counts from the specified time (e.g. t=8 min) compared to t=0 minutes.

Looking at the right two columns per time increment, there is a direct correlation between changes in cell counts and log-removal as would be expected. Each contaminant impacted log removal in a different manner. Sodium arsenate showed peak removal after eight minutes of exposure. Even though the highest concentrations of sodium arsenate were used, it had a relatively light removal of cells. Sodium fluoroacetate showed peak removal after forty eight-minutes of exposure, and at that time, demonstrated between 85-100% cell removal. Aldicarb had the greatest removal after eight minutes of exposure, removing between 85-95% of the cells. Finally, sodium cyanide had low removal after one-minute, but increased steadily until peaking after 48-minutes of exposure to removing over 95% of cells.

There are two interesting data points in Table 6-2 that warrant discussion. The changes in cell counts for aldicarb are identical for the different concentrations. This is correct and accurate, just a rather unique circumstance. Also, the sodium cyanide change in cell counts for 0.5 mg/L shows an increase. This is surely an incident of the  $t=0$  coupon having minimal growth, and the  $t=1$  minute coupon have substantially more growth.

The turbidity responses and the changes in cell count and log removal data do not correlate well. This is surprising. It is suspected that in addition to reacting with biofilm on the coupon surfaces, the contaminants were also reacting with other substances in the water or in the bioreactors themselves. Extensive sanitation methods were used as described in Chapter 3, but the bioreactors have been well used before arriving at CSU, and have signs of iron oxide on surfaces that remained in place even after acid washes. In addition to this, local water is known to have seasonal manganese issues, and like iron

oxide, once it has attached to a surface, it is difficult to remove. Regardless of potential source of turbidity increases, it is safe to say that a portion of the turbidity increase is a result of toxicity induced biofilm sloughing based on the log-removal results. Given the potential interferences, it is hard to quantify and correlate an exact relationship. It is interesting to note, however; that these interferences will also be found in full-scale distribution systems. The point being that the introduction of very toxic contaminants to a distribution system will incur a significant (an order of magnitude in most cases) increase in turbidity in the distribution system, providing an increased signal to noise ratio, indicating that the system has been compromised.

Table 6-3 compares limits of detection between on-line instrument response only and limits of detection based on the biofilm work described above. The values in the right column of Table 6-3 reflect, for example, that after 5 mg/L of sodium arsenate was put in the bioreactor with the acclimated coupons, a very large increase in turbidity was measured. In all cases the increase far exceeded the  $3\sigma$  value for turbidity previously found to be 0.07 NTU from the baseline monitoring. All values in the right column are qualified with a less-than sign because the turbidity response was so great, it is anticipated that if smaller contaminant concentrations were used, the turbidity response would still be well above  $3\sigma$ , and hence, the limit of detection would be reduced.

Chapter 4 determined limits of detection for the four contaminants using on-line water quality instruments without consideration of the impact that toxicity induced biofilm sloughing may have, particularly on turbidity. As can be seen in Table 6-3, turbidity was a defining surrogate for three of the four contaminants using on-line instrumentation. Comparing the limits of detection from the previous work with the

impact of biofilm detectability, the previous results seem pretty conservative, indicating that using on-line turbidity as a water quality surrogate will be even more sensitive to the introduction of toxic chemical contaminants than previously thought.

Another important point is the impact that the contaminant had on turbidity readings with respect to time. As Table 6-2 demonstrates, the increase in turbidity is very large and very quick, with all changes in turbidity readings near or much greater than one NTU after only one-minute of contaminant exposure. The values reflected in the right column of Table 6-3 are all certainly valid for exposure times of 1-minute based on the experiments, and perhaps even less. The significance of this is the ability to receive very quick feedback based on large changes in turbidity to aid in determining that a contamination event has taken place, or put another way, to improve the response time of an effective early warning system.

**Table 6-3** Limits of detection from previous work compared to biofilm detectability

Contaminant	Limit of Detection (mg/L)	Biofilm Detectability (mg/L)
Sodium Arsenate	< 15 <sup>a</sup>	< 5
Sodium Fluoroacetate (1080)	3 <sup>a,b</sup>	<0.5
Aldicarb	1 <sup>b,c</sup>	<0.25
Sodium Cyanide	<0.5 <sup>a,c</sup>	<0.25

<sup>a</sup>Turbidity was a defining surrogate

<sup>b</sup>pH was a defining surrogate

<sup>c</sup>Chlorine residual was a defining surrogate

#### **6.4 Conclusions**

Drinking water distribution systems contain biofilm as part of the natural aquatic environment. This study considered the impact of chemical contamination on biofilm sloughing, and the resulting increase in turbidity. The interaction between toxic industrial chemicals and biofilm in the distribution system resulted in cell death, and the sloughing off of biomass. There were also other interactions that potentially took place between the contaminant, bioreactor surfaces, and the bulk phase. As was demonstrated in the cell count experiments, there was a correlation between introduction of a chemical contaminant and the log-removal of cells from PVC coupons. It was further demonstrated that the sloughed-off biomass contributed to a significant increase in turbidity. This increase in turbidity reduced the limit of detection of chemical contaminants by increasing the signal to noise ratio of the contaminant-instrument response. Turbidity was highlighted in the literature review as a water quality surrogate that may work well for the detection of contamination events. The results of these experiments add to the emphasis already placed on on-line turbidity monitoring. They further emphasize that biofilm in the distribution system is a key consideration for the impact that on-line turbidity monitoring may have on detecting toxic industrial chemicals. This is key to providing early warning in the event of distribution system chemical contamination, in an effort to protect public health.

## CHAPTER 7 CONCLUSIONS AND RECOMMENDATIONS

The threat of chemical contamination to drinking water is well established and requires an urgent effort to protect our drinking water systems from malevolent acts of sabotage. As it presently stands, the technology to detect these contaminants is lacking. Early detection of these contaminants via on-line or real-time monitoring has been identified as a feasible way to provide early warning to protect public health.

One of the first steps in conducting on-line monitoring of a distribution system must include establishing baseline water quality. The baseline will provide a significant amount of data that represents "normal" conditions to compare suspected contamination events to. Without the baseline, or an adequate baseline, all else is lost.

Results from this effort indicate that routine water quality instruments can detect chemical disturbances in drinking water distribution systems. Three of the four chemical contaminants were detected at concentrations below those that would cause significant health impact when considering only contaminant-instrument response. It was shown that toxicity induced biofilm sloughing in the distribution system may send an amplified turbidity signal, thus either decreasing the limit of detection of a chemical contaminant or providing an earlier warning that a contamination event has occurred. This is a significant finding in that biofilms are considered a natural part of the distribution system, and likely exist to some extent in all distribution systems.

Additionally, cluster analysis was found to detect a contamination event as fast as or faster than univariate analysis in over 62% of the cases evaluated. Cluster analysis offers the advantage of utilizing all on-line water quality data simultaneously to detect

combinations of changes in the different water quality parameters instead of relying on a relatively large change in a single parameter.

This study was successful in addressing the hypotheses identified in section 2.16, as presented in the above paragraphs. Limitations to this study were identified in section 1.3, and in hind-sight, should be re-emphasized here as recommendations for further study. The first of which should be studying many more credible threat contaminants, particularly amongst the different contaminant classes (chemical, microbiological, toxin, and radiological) to understand their impact on water quality, and more significantly, determine if there are gaps that exist between specific contaminants and the capability to use water quality surrogates to detect them. In this effort, all four chemical contaminants were successfully detected at meaningful concentrations.

Another opportunity, which utilities in particular would be interested in, would lie in running a large number of organic threat contaminants through the bench scale distribution system and cataloging other (besides TOC) surrogate instrument responses. Depending on the outcome of this study, it may provide relief to the utilities from the relatively expensive on-line TOC analyzers if other water quality surrogates are sensitive to the organics. In this study, aldicarb and sodium fluoroacetate both impacted other water quality surrogates enough to detect them below health threat concentrations.

The use of other pattern recognition techniques may also prove more effective at reducing the time that it would take to detect a contamination event. Kohonen neural networks or self-organizing maps may prove superior to k-means clustering, and provide the reduced limit of detection that this important challenge needs. Additionally, pre-processing of the data may lend more power to clustering analysis and other techniques.

The effect that conductivity had on the cluster results is likely due to scaling issues (~120 uS/cm per reading versus 0.2 NTU for turbidity). It would be interesting to put the conductivity in units of mS/cm, reducing the magnitude from approximately 120 to 0.12, and running the data through the k-means algorithm to determine if conductivity still plays such a significant role. Similarly, conductivity had a relatively large variance and range, and normalizing all of the data to a mean of zero and a standard deviation of one would also likely impact the results. Due to the likely impact that the lack of pre-processing of the data may have had, it would be remiss to claim conductivity as having the impact that it displayed without first running the pre-processed data through the k-means algorithm to see if a similar result is achieved.

Recommendations for further biofilm work would include decreasing the contaminant concentrations in an effort to determine the actual (versus "less than") limits of detection for the contaminants when introduced to the bioreactors. This may provide more insight into the impact that consideration of biofilms may have in determining instrument response. Another prospective area of research may include conducting the biofilm tests in-situ. This would involve growing the biofilm off-line on the PVC coupons, then carefully placing the acclimated coupons in coupon holders that were mounted flush into bench-scale distribution system piping, and then completing similar experiments with the introduction of contaminants. This would provide large data sets from the on-line instruments, and would involve real-world flow instead of simulating flow conditions by adjusting the RPM setting on the bioreactor.

One last note about biofilm may prove to be a diversion. As has been noted, biofilms are a natural part of the aquatic environment in a drinking water distribution

system. The literature review briefly discussed biomonitors, with the thought of using biomonitors for drinking water difficult to implement due to the oxidant residual in the distribution system. What is being overlooked is the potential to use biofilm as a biomonitor for drinking water. It would certainly take a considerable amount of research, but certainly cells in the biofilm will elicit responses after exposure to a contaminant in the distribution system. This was certainly shown in the biofilm study in Chapter 6. With the right monitoring technology, perhaps at the cellular level, cells in biofilm may produce a response when under stress and provide even earlier warning than technologies considered in this research effort.

The question will always be asked, "if I had to choose only one or two detectors (budget issue maybe?) to put in the distribution system, what should they be?" Based on this effort, turbidity was emphasized in Tables 4-4, 5-1, and 6-3, especially in light of the biofilm study, as being a surrogate of choice. A laser turbidimeter was also used in this study because of its increased sensitivity and accuracy. Unfortunately, it was too sensitive for the task at hand providing false positives in abundance. The standard turbidimeter (1720D) performed very well. Conductivity was favored in Table 5-1, and was also found to impact cluster analysis significantly on its own. Without pre-processing the data before the cluster analysis was conducted, it would be difficult to place much weight on conductivity having the significance that it displayed.

Chlorine residual is a favorite in the literature review, and in this study, really showed an instrument response in a step-like manner for contaminants with a known chlorine demand. This step-like response is an important consideration because there is no doubting a response of this magnitude assuming that the instrument is working

properly. This brings up another consideration--of all of the instruments that were used in this study, the chlorine analyzer seemed to be the most sensitive to operational conditions, namely flow.

That leaves TOC and pH. TOC, as previously mentioned, is relatively expensive, and surprisingly, was only favored in Table 5-1, and then for only one of the two organics. In some water quality areas, pH is often cited as a key parameter, but in this study it really wasn't as significant as some of the others. This was surprising, as the alkalinity of the local water averages 40 mg/L as CaCO<sub>3</sub>, which is pretty low. With a low alkalinity, pH is not buffered, and should be very responsive. If pH wasn't responsive here, it surely won't be responsive in higher alkalinity waters.

The most robust detection systems will include the use of multiple sensors per location, at multiple locations in the distribution system, and the use of advanced data analysis techniques such as cluster analysis, to provide early warning in the event of contamination at the lowest contaminant concentration possible, as quickly as possible. All of this in the name of securing the nation's drinking water and protecting public health.

## REFERENCES

1. Afifi, A., Clark, A.C., May, S. (2004). *Computer-Aided Multivariate Analysis*, Chapman & Hall/CRC, FL.
2. Allmann, T.P. (2003). *Drinking Water Distribution System Modeling For Predicting The Impact And Detection Of Intentional Chemical Contamination*, Thesis, Department of Civil Engineering, Colorado State University, Fort Collins, CO.
3. Anderberg, M.R. (1973). *Cluster Analysis for Applications*, Academic Press, NY.
4. AWWA Research Foundation (2002). *Online Monitoring for Drinking Water Utilities*, AWWA, CO.
5. Baron, R.L. (1994). "A Carbamate Insecticide: A Case Study of Aldicarb," *Environmental Health Perspectives*, 102:11:23-27.
6. Benjamin, M.M. (2002). *Water Chemistry*, McGraw Hill, New York.
7. Biosurface Technologies Corporation (1998). "Operations Manual Model 1120LJ Laboratory-Jacketed Regrowth Monitor and Annular Reactor," Montana.
8. Boe-Hansen, R., Alrbechtsen, H., Arvin, E., and Jorgensen, C. (2002). "Bulk Water Phase and Biofilm Growth in Drinking Water at Low Nutrient Conditions," *Water Research*, 36:4477-4486.
9. Burrows, W.D., Valcik, J. A., and Seitzinger, A. (1997). "Natural and Terrorist Threats to Drinking Water Systems," presented at the American Defense Preparedness Association 23rd Environmental Symposium and Exhibition, New Orleans, LA.
10. Burrows, W.D., and Renner, S.E. (1999). "Biological Warfare Agents as Threats to Potable Water," *Environmental Health Perspectives*, 107:12:975-984.
11. Butterfield, P.W., Camper, A.K., Ellis, B.D., and Jones, W.L. (2002). "Chlorination of Model Drinking Water Biofilm: Implications for Growth and Organic Carbon Removal," *Water Research*, 36:4391-4405.
12. Camper, A.K. (1995). *Factors Influencing Biofilm Growth in Drinking Water Distribution Systems*, Dissertation, Department of Civil Engineering, Montana State University, MO.
13. Camper, A.K. (1996). *Factors Limiting Growth in Distribution Systems: Laboratory and Pilot-Scale Experiments*. AWWARF, CO.

14. Centers for Disease Control and Prevention (1999). "Changes in the Public Health System," *Morbidity and Mortality Weekly Report*, 48:50:1141-1147.
15. Characklis, W.G., (1988). *Bacterial Regrowth in Distribution Systems*. AWWARF, CO.
16. Clark, R.M., and Deininger, R.A. (2000). "Protecting the Nation's Critical Infrastructure: The Vulnerability of U.S. Water Supply Systems," *Journal of Contingencies and Crisis Management*, 8:2:73-80.
17. Clark, R.M., Haught, R., and Panguluri, S. (2002). "Remote Monitoring and Network Models: Their Potential for Protecting the Nation's Water Supplies," Presented at Workshop on Advanced Technologies in Real-Time Monitoring and Modeling for Drinking Water Safety and Security, Newark, New Jersey.
18. Confidential US Government Report.
19. Costerton, J.W., and Lappin-Scott, H.M. (1989). "Behavior of Bacteria in Biofilms," *American Society of Microbiology News*, 55:650-654.
20. Deininger, R.A. (2000). "The Threat of Chemical and Biological Agents to Public Water Supply Systems," Water Pipeline Database, TSWG Task T-1211, SAIC Hazard Assessment and Simulation Division, Contract N 39998-00-C-0663, VA..
21. Deininger, R.A., Literathy, P., and Bartram, J. (2000). *Security of Public Water Supplies*, Kluwer Academic Publishers, The Netherlands.
22. DeNileon, G.P. (2001). "The Who, What, Why, and How of Counterterrorism Issues," *Journal of the American Water Works Association*, 93:5:78-85.
23. DeYoung, T.J. and Gravley, A. (2002). "Coordinating Efforts to Secure American Public Water Supplies," *Natural Resources and Environment*, 16:3:146-152.
24. Donlan, R.M., and Pipes, W.O. (1988). "Selected Drinking Water Characteristics and Attached Microbial Population Density," *Journal of the American Water Works Association*, 80:70-75.
25. Eisler, R. (1995). *Sodium Monofluoroacetate (1080) Hazards to Fish, Wildlife, and Invertebrates: A Synoptic Review*, Biological Report 27, U.S. Department of the Interior, National Biological Service, Washington, D.C.
26. Engelbrecht, A.P. (2002). *Computational Intelligence, An Introduction*, John Wiley & Sons Ltd., England.

27. Federal Register (1996). "Executive Order 13010, Critical Infrastructure Protection," Vol. 61, No. 138.
28. Flemming, H., Szewzyk, U., and Griebe, T. (2000). *Biofilms: Investigative Methods & Applications*, Technomic Publishing Company, PA.
29. *Fort Collins Utilities Annual Operating Report* (2001), City of Fort Collins, CO
30. Fransolet, G., Villars, G., Masschelein, W.J. (1985). "Influence of Temperature on Bacterial Development in Waters," *Journal International Ozone Association* 7:205-227.
31. Gilbert, R.O. (1987). *Statistical Methods for Environmental Pollution Monitoring*, Van Nostrand Reinhold, NY.
32. Guler, C., Thyne, G.D., McCray, J.E., and Turner, A.K. (2002). "Evaluation of Graphical and Multivariate Statistical Methods for Classification of Water Chemistry Data," *Hydrogeology Journal*, 10:455-474.
33. Hartigan, J.A. (1975). *Clustering Algorithms*, John Wiley & Sons, USA.
34. Hastie, T., Tibshirani, R. and Friedman, J. (2001). *The Elements of Statistical Learning; data mining, inference, and prediction*, Springer Publishing, Canada.
35. Herschel, C. (1973). A translation into English, and explanatory chapters of the two books on the water supply of the city of Rome, *De aquae ductibus urbis Romae* originally written by Sextus Julius Frontinus in A.D. 97. New England Water Works Association, Boston.
36. Hoover, J.E. (1941). "Water Supply Facilities and National Defense," *Journal of the American Water Works Association*, 33:11:1861-1865.
37. Howard, N. (1940). "Bacterial Depreciation of Water Quality in Distribution Systems," *Journal AWWA* 32:1501-1506.
38. Khan, A.S., Levitt, A.M., and Sage, M.J. (2000). "Biological and Chemical Terrorism: Strategic Plan for Preparedness and Response," *Morbidity and Mortality Weekly Report : MMWR / Center for Disease Control*, 49(RR04):1-14.
39. Khan, A.S., Swerdlow, D.L., and Juranek, D.D. (2001). "Precautions against Biological and Chemical Terrorism Directed at Food and Water Supplies," *Public Health Reports*, 116:3-12.
40. Kirmeyer, G.J., Friedman, M., Martel, K.D., Howe, D., LeChevallier, M., Abbaszadegan, M., Karim, M., Funk, J., and Harbour, J. (2001). *Pathogen Intrusion Into The Distribution System*, AWWARF, CO.

41. Krieger, R.I. (2001). *Handbook of Pesticide Toxicology*, Volume 2, 2nd Edition, Academic Publishing, CA.
42. Landers, J. (2003). "Pilot Project, Web Service Focus on Security," *Civil Engineering*, 73:2:33-34.
43. Lawrence, J.R., Swerhone, G.D.W., and Neu, T.R. (2000). "A Simple Rotating Annular Reactor for Replicated Biofilm Studies," *Journal of Microbiological Methods*, 42:215-224.
44. LeChevallier, M.W. (1989). "Treatment To Meet The Microbiological MCL In The Face Of A Coliform Regrowth Problem," *Proceedings AWWA Water Quality Tech Conf, Philadelphia, PA, AWWA, Denver, CO*
45. LeChevallier, M.W., Schulz, W.H., and Lee, R.G. (1990). "Bacterial Nutrients in Drinking Water." In: *Assessing and Controlling Bacterial Regrowth in Distribution Systems*. American Water Works Association and American Water Works Association Research Foundation, Denver, CO.
46. LeChevallier, M.W. (1999). "The Case for Maintaining a Disinfectant Residual," *Journal of the American Water Works Association*, 91:1:86-94.
47. Luthy, R.G. (2002). "Bioterrorism and Water Security," *Environmental Science & Technology*, 36:7:123A.
48. Macler, B., Connell, G., and Routt, J. (2000). *American Water Works Association Committee Report: "Disinfection at medium size and large systems," Journal of the American Water Works Association*, 92:5:32-43.
49. Manahan, S.E. (1992). *Toxicological chemistry, 2nd edition*, Lewis Publishers, FL.
50. Mays, L.W. (2000). *Water Distribution Systems Handbook*, McGraw-Hill, USA.
51. Miller, J.N. and Miller, J.C. (2000). *Statistics and Chemometrics for Analytical Chemistry*, 4th edition, Pearson Education, England.
52. National Academy of Engineering (2000). "National Academy of Engineering Reveals Top Engineering Impacts of the 20th Century: Electrification Cited as Most Important," *National Academy of Engineering Press Release, Feb 22, 2000*.
53. National Archives and Records Administration (2002). "Public Law 107-188, The Public Health Security and Bioterrorism Preparedness and Response Act," <http://www.access.gpo.gov/nara/publaw/107publ.html>.

54. National Research Council (2002). *Making the Nation Safer: The Role of Science and Technology in Countering Terrorism*, The National Academies Press, Washington, D.C.
55. Norman, N.C. (1998). *Chemistry of Arsenic, Antimony, and Bismuth*, Blackie Academic & Professional, London.
56. Ollos, P.J., Huck, P.M., and Slawson, R.M. (2003). "Factors Affecting Biofilm Accumulation in Model Distribution Systems," *Journal AWWA* 95:1:87-97.
57. Panguluri, Srinivas (2002). "Real Time Monitoring of a Distribution System: A Case Study," Presented at the Second Workshop on Advanced Technologies in Real-Time Monitoring and Modeling for Drinking Water Safety and Security, Newark, NJ.
58. Parmlee, M.A. (2002). "Public Health, Security Priorities Pushing for Better Water Quality Monitoring," *Journal American Water Works Association*, 94:10:14-26.
59. Pedersen, K. (1990). "Biofilm Development on Stainless Steel and PVC Surfaces in Drinking Water," *Water Research*, 24:2:239-243.
60. Percival, S.L., Walker, J.T., and Hunter, P.R. (2000). *Microbiological Aspects of Biofilms and Drinking Water*, CRC Press, Florida.
61. Prager, J.C. (1996). *Environmental Contaminant Reference Databook, Volume II*, Van Nostrand Reinhold, New York.
62. Reuter, R. (2002). "Detailed Strategy to Identify and Evaluate Potential Field Drinking Water Health Threats," U.S. Army Center for Environmental Health Research through Geo-Centers, Inc., Md.
63. Rittman, B.E. and McCarty, P.L. (2001). *Environmental Biotechnology*. McGraw-Hill, NY, NY.
64. Rizet, M., Fiessinger, F., and Houel, N. (1982). "Bacterial Regrowth in a Distribution System and its Relationship with the Quality of the Feed Water: Case Studies. Proceedings AWWA Annual Conference, Miami Beach, FL.
65. Rose, J.B. (2002). "Water Quality Security," *Environmental Science & Technology*, 36:11:247A-250A.
66. Samset, I.D., Hermansen, L.F., and Berg, J.D. (2000). "Development of a Surveillance System for Water Treatment Processes and Hygienic Quality of Drinking Water," presented at Drinking Water Research Towards Year 2000, Trondheim, Norway, 5-7 Jan 2000.

67. Sax, N.I., and Lewis, R.J. (1989). *Dangerous Properties of Industrial Materials, 7th edition*, Van Nostrand Reinhold, New York.
68. Sharfenaker, M.A. (2002). "White Papers Set Stage for Regulating Distribution System Water Quality," *Journal American Water Works Association*, 94:10:14-26.
69. Sibille, I., Sime-Ngando, T., Mathieu, L., and Block, J.C. (1998). "Protozoan Bacterivory and *Escherichia coli* Survival In Drinking Water Systems," *Applied Environmental Microbiology*, 64:197-202.
70. Sidell, F.R., Takafuji, E.T., and Franz, D.R. (1997). *Medical Aspects of Chemical and Biological Warfare*, Borden Institute, Washington DC.
71. States, S., Newberry, J., Wichterman, J., Kuchta, J., Scheuring, M., Casson, L. (2004). "Rapid Analytical Techniques for Drinking Water Security Investigations," *Journal American Water Works Association*, 96:1:52-64.
72. States, S., Scheuring, M., Kuchta, J., Newberry, J., and Casson, L. (2003). "Utility-based Analytical Methods to Ensure Public Water Supply Security," *Journal American Water Works Association*, 95:4:103-115.
73. Teter, David M. (2002). "Biological and Chemical Sabotage of Public Water Systems: A Threat Analysis and Recommended Countermeasures," Sandia National Laboratories, New Mexico.
74. Tiemann, M. (2002). "Safeguarding the Nation's Drinking Water: EPA and Congressional Actions," Congressional Research Service, The Library of Congress, Washington, D.C.
75. Trulear, M.G. and Characklis, W.G. (1982). "Dynamics of Biofilm Processes," *Journal of the Water Pollution Control Federation*, 54:1288.
76. USACHPPM TG 230 (2002). *Chemical Exposure Guidelines for Deployed Military Personnel*, Appendix D, US Army, Md.
77. US Environmental Protection Agency (1992). *Control of Biofilm Growth in Drinking Water Distribution Systems*, EPA Publication 625/R-92/001.
78. US Environmental Protection Agency (2002). "EPA Awards \$500,000 to Launch Drinking-Water Security Pilot; Consortium on Security Formed," EPA News Release #02130, New York.
79. Vershueren, K. (2001). *Handbook of Environmental Data on Organic Chemicals, 4th Edition, Volume 1*, Wiley, New York.

80. Volk, C.J. and LeChevallier, M.W. (1999). "Impacts of the reduction of nutrient levels on bacterial water quality in distribution systems," *Applied Environmental Microbiology*, 65:11:4957-4966.
81. Watters, S.K. and McFeters, G.A. (1990). "Reactivation of Injured Bacteria." In: *Assessing and Controlling Bacterial Regrowth in Distribution Systems*. AWWA and AWWARF, CO.
82. Wolff, D.D. and Parsons, M.L. (1983). *Pattern Recognition Approaches to Data Interpretation*, Plenum Press, NY.
83. Wooschlager, J.E., Rittmann, B.E., Piriou, P. and Schwartz, B. (2001). "Developing an Effective Strategy to Control Nitrifier Growth Using the Comprehensive Disinfection and Water Quality Model." *In Proc. World Water and Environmental Resources Congress*. VA, ASCE.

## **APPENDIX A    INSTRUMENTS AND TEST KITS**

Table A-1 provides a summary of information on selected instruments that are presently available to monitor contaminants in water. The table is arranged by manufacturer alphabetically and provides a brief summary of the instrument or test kit. The summary table is separated into two distinct groups--those instruments that are presently available (Table A-1) and those that represent an emerging technology (Table A-2). For those instruments that are in the emerging technology category, references to title projects, authors, and brief descriptions of the technology are provided.

**Table A-1** Summary of commercially available instruments and testing kits.

Instrument/Testing Kit	Manufacturer	Parameters Observed/Sampled
4670 Series Turbidity System	ABB Instrumentation	turbidity
Series B20 Residual Chlorine Recorder	Analytical Technology, Inc.	free chlorine, chloramines
bbe Algae Online Analyser	bbe	direct chlorophyll fluorescence (this measurement corresponds to the wet-chemical chlorophyll analysis); active chlorophyll fluorescence (Genty Parameter -- this measurement shows the percentage of active chlorophyll under defined conditions); transmission (in order to compensate the influence of substances which cause turbidity, transmission measurement takes place automatically during each analysis); differentiation of fluorometrical algae classes (it is possible to determine at least the content of chlorophyll according to green algae, bacillariophyceae (diatoms, dinoflagellates, ...), blue-green algae, cryptophyceae)
Tox Screen	CheckLight, Ltd.	aldicarb, colchicines, cyanide, dicrotophos, thallium sulfate, botulinum toxin, ricin, soman, VX
VVR Water Anlysis System	Chemetrics	ammonia, bromine, chlorine, chlorine dioxide, chromate, copper, cyanide, DEHA, formaldehyde, glycol, hydrazine, hydrogen peroxide, iron, molybdate, nitrate, nitrite, oxygen (dissolved), ozone, peracetic acid, phenols, phosphate, silica, sulfide, zinc

Instrument/Testing Kit	Manufacturer	Parameters Observed/Sampled
Colifast At-line Monitor (CALM)	Colifast	Provides water quality data for thermotolerant coliforms/ <i>E.coli</i> and total coliforms.
Colifast Analyzer (CA)	Colifast	Tests for thermotolerant coliforms / <i>E.coli</i> , total coliforms, Total Viable Organisms and <i>P. aeruginosa</i> , are available.
Cyranose <sup>®</sup> 320	Cyrano Sciences	The unique polymer composite sensors have been shown to respond to a wide range of organic compounds, bacteria and natural products.
Six-CENSE <sup>™</sup>	Dascore	chlorine (no reagents required), monochloramine or dissolved oxygen, pH, temperature, conductivity, ORP/REDOX
RiboPrinter <sup>®</sup> Microbial Characterization System	DuPont Qualicon	Up to eight bacterial isolates can be tested at one time, with results available eight hours from sample input.
miniTROLL	Electronic Data Solutions	collect real-time information for analysis of both short- and long-term water level trends
MP-TROLL 9000	Electronic Data Solutions	surface water quality monitoring, dissolved oxygen
Ocean Seven 316 Water Probe	General Oceanics, Inc.	The probe is equipped with the following standard sensors to measure: pressure, temperature, conductivity, salinity, oxygen, pH, oxidation-reduction potential.
WDM PipeSonde In-Pipe Probe	Hach	pH, ORP, conductivity, turbidity, dissolved oxygen, line pressure, temperature
Water Distribution Monitoring Panel (WDMP)	Hach	chlorine, conductivity, pH, turbidity, pressure, temperature
Color Disc-based Test Kit	Hach	
MEL P/A Safe Drinking Water Laboratory	Hach	total coliforms and <i>E.coli</i> , chlorine, nitrate, TDS, pH
ToxTrak Toxicity Test Kit	Hach	toxicity of wastes and chemicals in wastewater treatment processes
astroTOC HT (High Temperature)	Hach	TOC measurement
1950plus On-line TOC Analyzer	Hach	TOC measurement
AccuChlor 2 Residual Chlorine Measurement System	Hach	chlorine
CL17 Free Residual Chlorine Analyzer	Hach	chlorine
Series 4 Multiparameter	Hydrolab	ammonium, chloride, conductivity, dissolved

Instrument/Testing Kit	Manufacturer	Parameters Observed/Sampled
Water Quality Monitoring Sondes		oxygen, nitrate, pH/reference, pH/ORP/reference, temperature, TGD, turbidity, chlorophyll, PAR
Quanta – Display Multiparameter Water Quality Instrument	Hydrolab	temperature dissolved oxygen, conductivity, pH, ORP (redox), depth, turbidity
Quanta-G – Transmitter Multiparameter Water Quality Instrument	Hydrolab	temperature dissolved oxygen, conductivity, pH, ORP (redox), depth, turbidity
Quanta – Transmitter Multiparameter Water Quality Instrument	Hydrolab	temperature dissolved oxygen, conductivity, pH, ORP (redox), depth, turbidity
Quick™ II Test Kit and four other kits	Industrial Test Systems, Inc.	arsenic
PolyTox™ Rapid Toxicity Test	InterLab Supply, Ltd.	pH, dissolved oxygen (ppm), temperature (°C), toxic metals (ppm)
BIOX 1010 BOD Analyzer	ISCO, Inc.	BOD measurement
EZ TOC Continuous Low-temperature On-line TOC/TC Analyzer	ISCO, Inc.	TOC measurement
STIP-toc Continuous High-temperature On-line TOC Analyzer	ISCO, Inc.	TOC measurement
STIPTOX-adapt (W) On-line Toximeter	ISCO, Inc.	TOC measurement
Threat Detection Kit™	Kingwood Diagnostics, LLC	The Threat Detection Kit not only can be used to assess water contamination after a security breach - but, also should be considered as at tool for daily monitoring - in effect an early warning system.
SMART 2 Colorimeter with the 3660-SC Reagent System Portable Cyanide Analyzer	LaMotte Company	Alkalinity UDV, Aluminum, Ammonia, Nitrogen-LR (Fresh Water), Ammonia, Nitrogen-LR (Salt Water), Ammonia Nitrogen, Boron, Bromine LR, Bromine UDV, Cadmium, Carbohydrazide, Chloride TesTab, Chlorine, Chlorine Free UDV, Chlorine Liquid DPD, Chlorine Total UDV, Chlorine Dioxide, Chromium, Hexavalent, Chromium TesTab, Chromium (Total, Hex & Trivalent), Cobalt, COD LR 0-150 with Mercury, COD LR 0-150 without Mercury, COD SR 0-1500 with Mercury, COD SR 0-1500 without Mercury, COD HR 0-15,000 with Mercury, COD HR 0-15,000 without Mercury, Color, Copper BCA – LR, Copper Cuprizone, Copper DDC, Copper UDV, Cyanide, Cyanuric Acid, Cyanuric Acid UDV, DEHA, Dissolved Oxygen (DO), Erythorbic Acid, Fluoride, Hydrazine, Hydrogen Peroxide, Hydroquinone, Iodine, Iron, Iron UDV, Iron Phenanthroline, Lead, Manganese LR,

Instrument/Testing Kit	Manufacturer	Parameters Observed/Sampled
		Manganese HR, Mercury, Methyleneketoxime, Molybdenum HR, Nickel, Nitrate Nitrogen LR, Nitrate TesTab, Nitrite Nitrogen LR, Nitrite TesTab, Ozone LR, Ozone HR, pH CPR (Chlorphenol Red), pH PR (Phenol Red), pH TB (Thymol Blue), Phenol, Phosphate LR, Phosphate HR, Potassium, Silica LR, Silica HR, Sulfate HR, Sulfide LR, Surfactants, Tannin, Turbidity, Zinc LR
PDV 6000 Heavy Metal Analyzer	Monitoring Technologies International, Pty. Ltd.	arsenic
AF46 Dual Channel UV Absorption Sensor	Optek	concentrations of acetone, aniline, benzene, halogens, HMF, hydrogen peroxide, ketones, trace mercury, nitric acid, ozone, phenols/phenates, sulfur dioxide, toluene, tracers, xylene
Mini-Analyst Model 942-032 Portable Cyanide Analyzer	Orbeco-Hellige	cyanide
Analyte 2000 Fiber Optic Fluorometer	Research International	performs evanescent-wave fluoroimmunoassays
Eclox™	Severn Trent Services	chemiluminescence testing, also includes equipment and specific tests to measure arsenic, pesticides /nerve agents, pH, total dissolved solids (TDS), color, chlorine
TOC-4110 On-line Water Quality Analyzer	Shimadzu North America	NPOC (acidify/sparge removal of IC) and TC (standard). NPOC, TOC (TC-IC) (option). NPOC, TOC (TC-IC and POC + NPOC) (option)
TOCN-4110 On-line Water Quality Analyzer	Shimadzu North America	NPOC (acidify/sparge removal of IC) and TC (standard). NPOC, TOC (TC-IC) (option). NPOC, TOC (TC-IC and POC+NPOC) (option)
TOCvsh On-line TOC analyzers	Shimadzu North America	Wide variety of measurement methods -- NPOC (TOC measurement by IC removal using acid sparging), TC (total carbon), and IC (inorganic carbon) measurements are all possible. Adding the optional TNM-1 allows continuous monitoring of TN (total nitrogen) in samples.
WTM500 On-line Turbidimeter	Sigrist	turbidity

Instrument/Testing Kit	Manufacturer	Parameters Observed/Sampled
Deltatox <sup>®</sup>	Strategic Diagnostics Inc. / Azur Environmental	partial list: phenol, lead, arsenic, mercury, sodium cyanide, selenium, potassium cyanide, chromium, PR-toxin, copper, aflatoxin, ochratoxin, rubratoxin, chloroform, ammonia, sodium lauryl sulfate, benzoyl cyanide, lindane, DDT, cresol, formaldehyde, malathion, carbaryl, fluoroacetate, trinitrotoluene (TNT), parathion, 4-phennyl toluene, carbofuran, pentachlorophenol, patulin, paraquat, diazinon, cyclohexamide, cadmium, quinine, dieldrin, microbiologicals
Model 500 Microtox <sup>®</sup>	Strategic Diagnostics Inc. / Azur Environmental	Microtox Acute Toxicity, Microtox Chronic Toxicity, Mutatox, ATP
SSS-33-5FT Drinking Water Rad-safety Monitor	Technical Associates	This detector measures alpha, beta, and gamma from any non-ionized radioactive liquids.
Apollo 9000 HS Combustion TOC Analyzer	Teledyne Tekmar	TOC measurement
Phoenix 8000 UV-Persulfate TOC Analyzer	Teledyne Tekmar	TOC measurement
F-NTK NECi Environmental Field Nitrate Test Kit	The Nitrate Elimination Co., Inc.	nitrate
AQUAfast <sup>®</sup> IV AQ4000 with AQ4006 Cyanide Reagents Portable Cyanide Analyzer	Thermo Orion (Thermo Electron Corporation)	cyanide
Model 96-06 Cyanide Electrode with Model 290 A+ Ion Selective Electrode Meter Portable Cyanide Analyzer	Thermo Orion (Thermo Electron Corporation)	cyanide
Nano-Band <sup>™</sup> Explorer Arsenic Test Kit	TraceDetect	arsenic
Aquafluor Fluorometer/Turbidimeter	Turner Designs	chlorophyll a, histamine, DO matter, ammonium, cyanobacteria, DNA, RNA, LIVE/ DEAD <sup>®</sup> BacLight <sup>™</sup> Bacterial Viability Assay, alkaline phosphatase fluorescence
Self-contained Underwater Fluorescence Apparatus (SCUFA)	Turner Designs	chlorophyll a and rhodamine WT versions
TD-700 Laboratory Fluorometer	Turner Designs	fluorescence, turbidity in one sample; available in three models: in vivo chlorophyll a/turbidity, rhodamine WT/turbidity, ammonium/extracted chlorophyll a
NAS-2E In-situ Nutrient Analyzer	WS EnviroTech	Four versions are available for the measurement of nitrate (and/or nitrite) phosphate,

Instrument/Testing Kit	Manufacturer	Parameters Observed/Sampled
		silicate, and now ammonia.
Cyanide Electrode CN501 with Reference Electrode %503D, and Multi-parameter handheld 340i	WTW Measurement Systems	pH, DO, temperature or pH, cond., cyanide
YSI 600 OMS Multi-parameter Probe	YSI Environmental	chlorophyll, rhodamine, or turbidity in combination with temperature, conductivity, and depth in fresh, sea or polluted water
YSI 600 QS (Quick Sample™) Multi-parameter Display-datalogger System	YSI Environmental	dissolved oxygen in mg/L, dissolved oxygen % saturation, temperature, conductivity, pH, ORP and depth are measured simultaneously
YSI 600 R Multi-parameter Probe	YSI Environmental	dissolved oxygen, temperature, conductivity, salinity, pH
YSI 600 XL Multi-parameter Probe	YSI Environmental	dissolved oxygen, temperature, conductivity, ORP, salinity, vented level, depth, pH, TDS, specific conductance
YSI 600 XLM Multi-parameter Probe	YSI Environmental	dissolved oxygen, open-channel flow, temperature, conductivity, vented level, salinity depth, ORP, pH
YSI 650 MDS Multi-parameter Display-datalogger System	YSI Environmental	handheld, rugged, waterproof display for all 6-series sondes
YSI ADV6600 Sonde Multi-parameter Probe	YSI Environmental	dissolved oxygen, conductivity, temperature, pH, ORP, pressure, velocity, direction, turbidity, chlorophyll, rhodamine, chloride, ammonia, and nitrate along with calculated parameters such as specific conductance and salinity
YSI 6600 Sonde Multi-parameter Probe	YSI Environmental	dissolved oxygen, open-channel flow, temperature, TDS, rhodamine, chlorophyll conductivity, vented level, specific conductance, nitrate-nitrogen, ammonium-nitrogen, ammonia, turbidity, chloride, salinity, depth, ORP, pH
YSI 6600 EDS (Extended Deployment System) Multi-parameter Probe	YSI Environmental	temperature/conductivity, turbidity, Rapid Pulse™ dissolved oxygen sensor, chlorophyll, and pH/ORP
YSI 6820 Multi-parameter Probe	YSI Environmental	dissolved oxygen, temperature, conductivity, TDS, vented level, nitrate-nitrogen, chlorophyll, rhodamine, ammonium-nitrogen, specific conductance, ammonia, turbidity, chloride, salinity, depth, ORP, pH

Instrument/Testing Kit	Manufacturer	Parameters Observed/Sampled
YSI 6920 Multi-parameter Probe	YSI Environmental	dissolved oxygen, open-channel flow, temperature, conductivity, vented level, nitrate-nitrogen, rhodamine, TDS, specific conductance, chlorophyll, ammonium-nitrogen, ammonia, turbidity chloride, salinity, depth, ORP, pH

**Table A-2** Summary of experimental-stage instruments.

Title/Project	Authors/Organization	Parameters Observed/Sampled
Heterogeneous Integration of CdS filters with GaN LEDs for Fluorescence Detection Microsystems	Chediak, J.A., L.Zhongsheng, S Jeonggi, N. Cheung, L.P. Lee, T. D. Sands	fluorescence
MEMS Bio-Chemical Transducer -- Calorimetric MEMS Sensor Array Platform	Britton, C. L.	(1) sensing and control of chemical and biological reactions such as those produced by glucose and cholesterol; and (2) real-time analyses of non-linear oscillating chemical reactions
Guidelines and Standard Procedures for Continuous Water-Quality Monitors: Site Selection, Field Operation, Calibration, Record Computation, and Reporting	Wagner, R. J., H. C. Mattraw, G. F. Ritz, and B. A. Smith	temperature, specific conductance, dissolved oxygen, and pH data, although systems can be configured to measure other properties such as turbidity or chlorophyll
Real-Time Remote Monitoring of a Distribution System – A Case Study in Washington D.C.	Panguluri, S., R. M. Clark, and R. C. Haught	This paper outlines: the steps involved in selecting an appropriate online real-time sampling system, the data acquisition system selection/setup criteria, security and dissemination of monitoring data and costs associated with the project.
Continuous Monitoring of Nitrate and Chlorophyll a in North Carolina Estuaries	Bales, J.D.	Sensors to measure near-surface and near-bottom nitrate concentration, fluorescence (chlorophyll a concentration), salinity, temperature, dissolved-oxygen, and pH. Nitrate and chlorophyll a were measured hourly and other parameters were measured at 15-minute intervals.
Sequential Injection Analysis-Based	Lapa, R. A. S., J. L. F. C.	nitrite and nitrate, simultaneously

Title/Project	Authors/Organization	Parameters Observed/Sampled
System for On-line Monitoring of Nitrite and Nitrate in Wastewater	Lima, and I. V. O. S. Pinto	
Continuous Water Quality Monitoring in Southern Kaneohe Bay: Linking Fluvial Nutrient and Sediment Inputs with Bay Water Quality and Reef Degradation	HCRI-RP (Hawaii Coral Reef Initiative Research Program)	nutrients and chlorophyll-a
Use of Biosensors for Bacterial Water Quality Monitoring	McLaughlin, J.	enzymes, antibodies, DNA or RNA, microorganisms
Pattern Recognition – Laser Scattering for Low Cost Bacteria Identification and Counting in Water Treatment	Rodrigues, M.A., D. Cooper, L. Alboul, J. Penders, A. Chamski, and G. Chliveros	Laser scattering can be used to determine the nature and the amount of bacteria in water samples through motion analysis. We are investigating pattern recognition techniques for identification and counting of bacteria in water treatment using the Rustek equipment pursuing the ultimate aim of the water industry, which is to detect one bacteria per 100ml of solution!
The “Dreissena-Monitor” – First Results on the Application of this Biological Early Warning System in the Continuous Monitoring of Water Quality	Borcherding, J. and M. Volpers	biological early warning system in the continuous monitoring of water quality
Drinking Water Early Warning Detection and Monitoring Technology Evaluation and Demonstration	VonderHaar, S. S., D. Macke, R. Sinha, E.R. Krishnan, and R. C. Haught	The instrument can be set to provide “alert” and “alarm” status at predetermined toxicity index values or limits. Test pollutants that are being evaluated include cadmium, atrazine, and dieldrin.

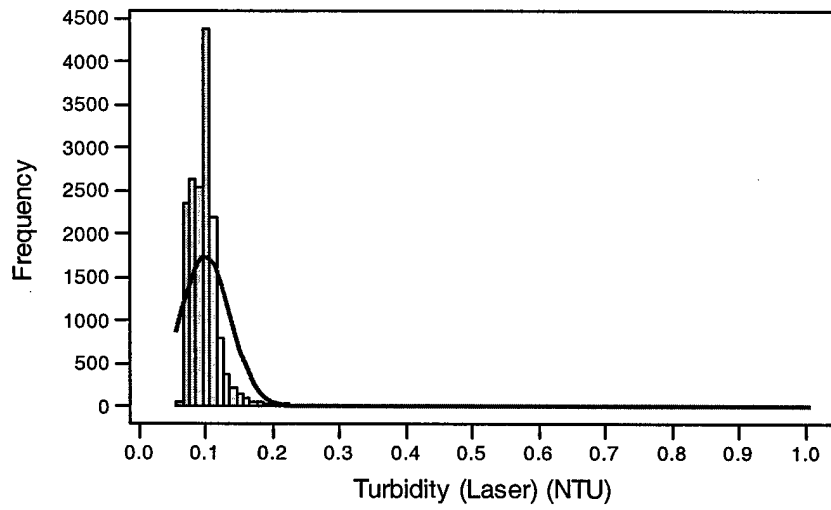
## **APPENDIX B    DISTRIBUTION SYSTEM DATA**

Appendix B provides a sample of the on-line data that was acquired during the experimental runs, histograms of the baseline data, and an example of a chart that was used to determine the detection limits in Table 4-4.

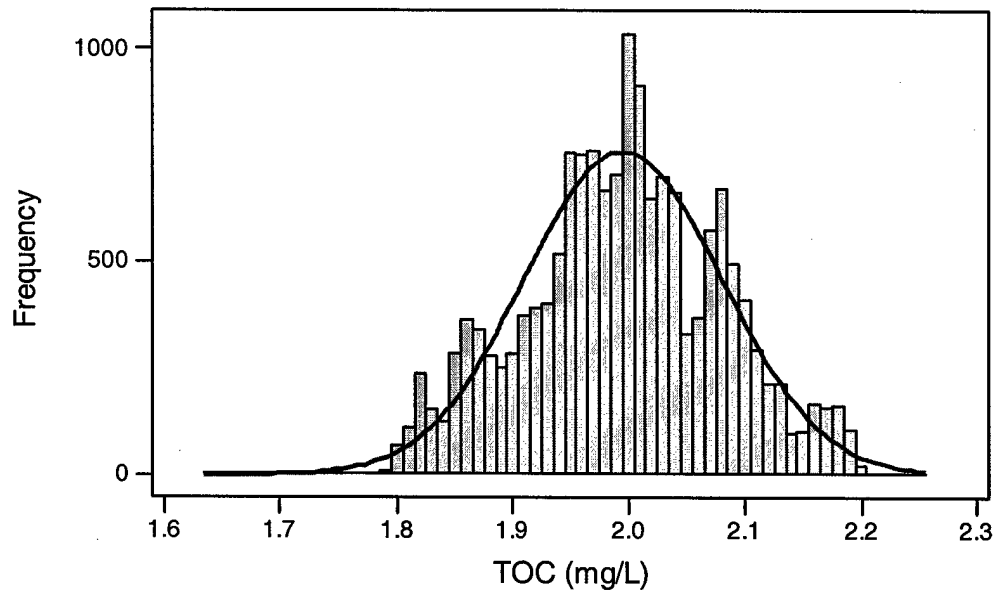
**Table B-1** Example of on-line data as collected.

Time	Conductivity (uS/cm)	pH	Turbidity (NTU)	Laser Turb (NTU)	Chlorine Residual (mg/L)	TOC (mg/L)
6/4/2003 9:43	131.498	7.906	0.138	0.131	0.54	1.955
6/4/2003 9:44	131.498	7.892	0.130	0.113	0.54	1.947
6/4/2003 9:45	131.498	7.888	0.128	0.114	0.54	1.953
6/4/2003 9:46	131.498	7.889	0.126	0.114	0.54	1.947
6/4/2003 9:47	131.498	7.889	0.124	0.120	0.54	1.948
6/4/2003 9:48	131.498	7.917	0.142	0.113	0.55	1.950
6/4/2003 9:49	131.498	7.888	0.122	0.118	0.54	1.948
6/4/2003 9:50	131.498	7.888	0.122	0.111	0.54	1.941
6/4/2003 9:51	131.498	7.889	0.121	0.116	0.54	1.950
6/4/2003 9:52	131.498	7.894	0.134	0.107	0.54	1.951
6/4/2003 9:53	131.498	7.916	0.138	0.110	0.55	1.941
6/4/2003 9:54	131.498	7.892	0.128	0.114	0.54	1.946
6/4/2003 9:55	131.498	7.893	0.121	0.108	0.54	1.953
6/4/2003 9:56	131.498	7.893	0.120	0.109	0.54	1.948
6/4/2003 9:57	131.498	7.890	0.120	0.109	0.54	1.954
6/4/2003 9:58	131.498	7.918	0.121	0.118	0.54	1.950
6/4/2003 9:59	131.498	7.894	0.125	0.110	0.54	1.940
6/4/2003 10:00	131.498	7.905	0.133	0.120	0.54	1.942
6/4/2003 10:01	131.498	7.894	0.141	0.146	0.54	1.944
6/4/2003 10:02	131.498	7.893	0.147	0.132	0.54	1.947
6/4/2003 10:03	131.498	7.914	0.148	0.143	0.54	1.943
6/4/2003 10:04	131.498	7.889	0.143	0.151	0.54	1.936
6/4/2003 10:05	131.498	7.902	0.135	0.122	0.54	1.935
6/4/2003 10:06	131.498	7.886	0.135	0.140	0.54	1.939
6/4/2003 10:07	131.498	7.888	0.130	0.111	0.54	1.945
6/4/2003 10:08	131.498	7.916	0.127	0.112	0.54	1.948
6/4/2003 10:09	131.498	7.886	0.126	0.112	0.54	1.945
6/4/2003 10:10	131.498	7.894	0.125	0.116	0.54	1.954
6/4/2003 10:11	131.498	7.898	0.124	0.119	0.54	1.946
6/4/2003 10:12	131.498	7.896	0.123	0.107	0.54	1.953

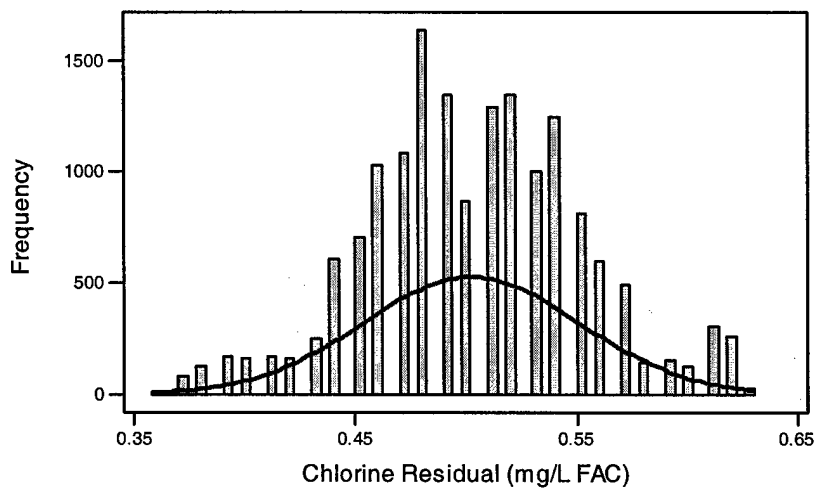
Figures B-1 through B-6 display histograms of the baseline data, with a normal curve plotted in red against the data. As can be seen, the data in most cases is obviously not normally distributed. In the case of a suspected normal distribution, for example TOC, the Anderson-Darling normality test was used in Minitab to quantitatively determine if the distribution was normal. The criteria for normality is a p-value greater than 0.05. The p-value for the TOC was 0.00 -- not normal. Environmental data can typically be fit to a log normal distribution (Gilbert, 1987). Similarly, the Anderson-Darling normality test was used to determine if the data distributions fit a lognormal distribution. All p-values for the different parameters were 0.00, indicating that the distributions are not lognormal.



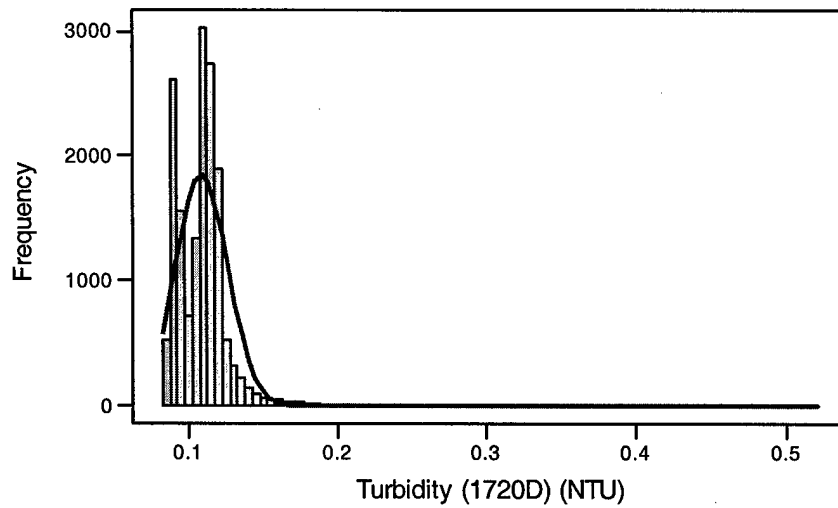
**Figure B-1** Histogram of laser turbidity with normal curve.



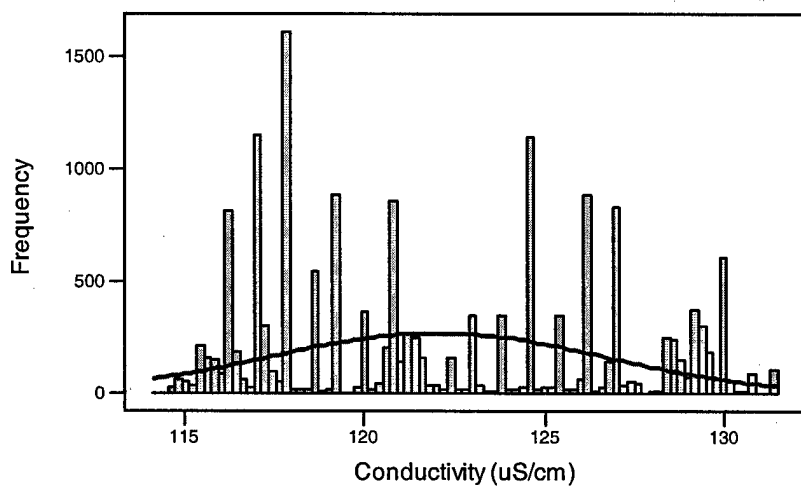
**Figure B-2** Histogram of TOC with Normal Curve.



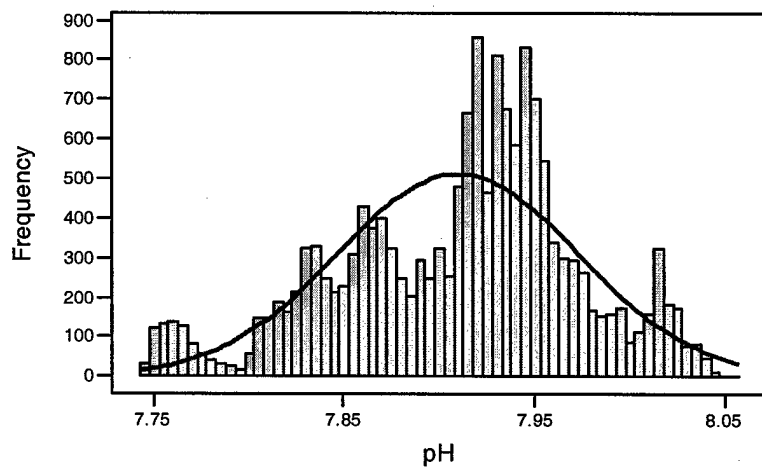
**Figure B-3** Histogram of Chlorine Residual with Normal Curve.



**Figure B-4** Histogram of Turbidity with Normal Curve.

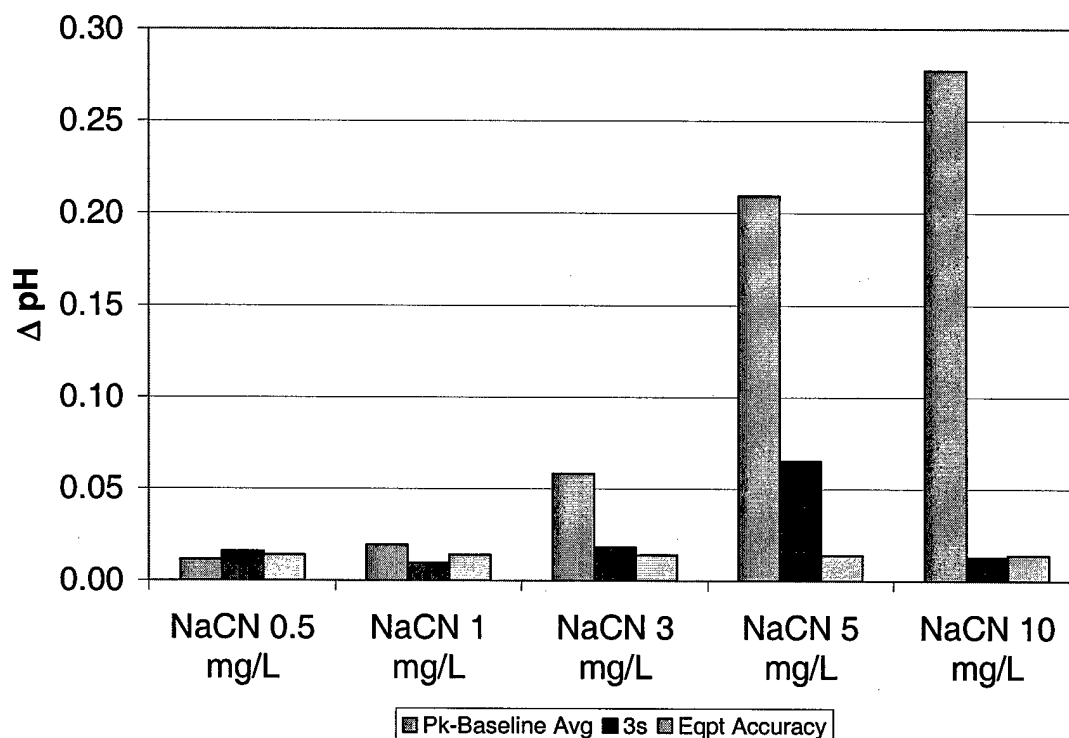


**Figure B-5** Histogram of Conductivity with Normal Curve.



**Figure B-6** Histogram of pH with Normal Curve.

Figure B-7 provides a chart that shows the change in pH at different concentrations for sodium cyanide compared to the baseline  $3\sigma$  and the manufacturers provided equipment accuracy. This type of analysis was key to determining the limits of detection provided in Table 4-4. In the figure below, the sodium cyanide pH response is just greater than the  $3\sigma$  and manufacturer provided equipment accuracy at 1 mg/L suggesting that pH would be a good water quality surrogate for detecting sodium cyanide at 1 mg/L.



**Figure B-7** Comparison of instrument response,  $3\sigma$ , and equipment accuracy

## APPENDIX C BEAKER TEST DATA

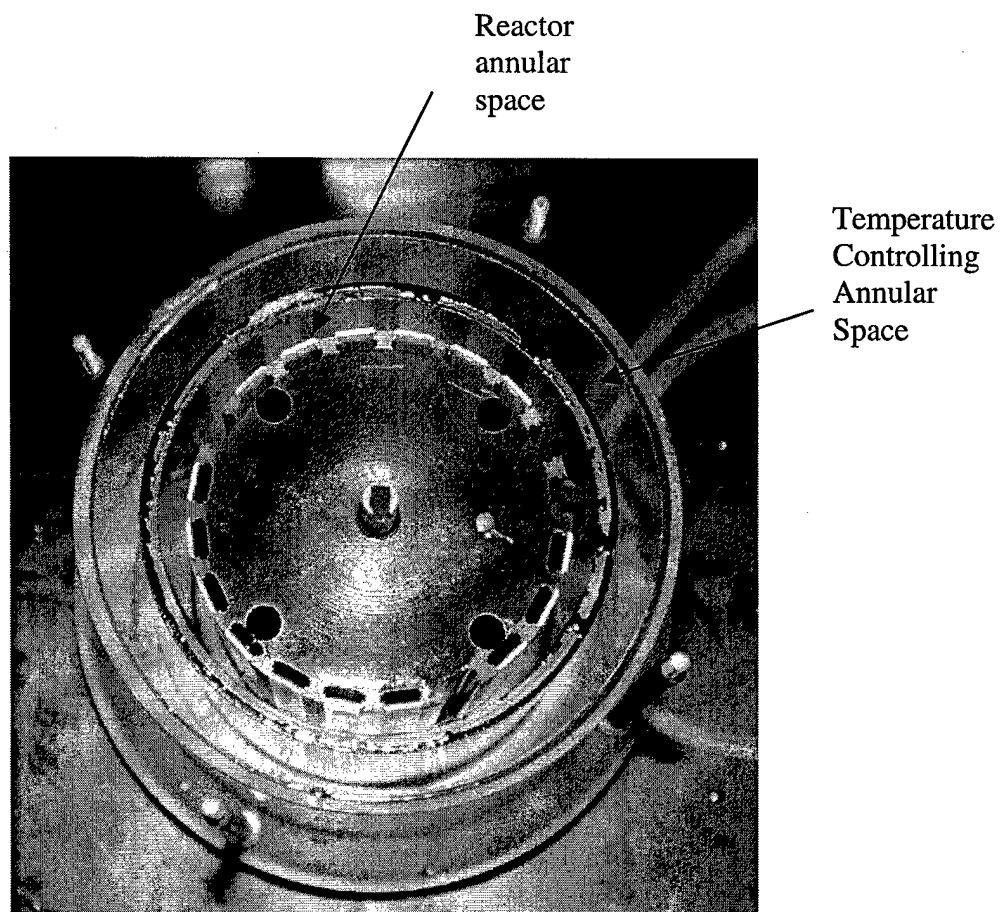
Table C-1 notes the changes in water quality parameters when the specified contaminant at the designated concentration was added to local tap water. These tests utilized bench top analytical equipment (versus on-line monitors).

**Table C-1** Beaker test experimental results

<b>Contaminant</b>	<b>Concentration (mg/L)</b>	<b>Δ Chl Res (mg/L)</b>	<b>Δ Cond (uS/cm)</b>	<b>Δ pH</b>	<b>Δ TOC (mg/L)</b>
<b>Sodium Arsenate</b>	0	0	0	0	0
	6	-0.02	0	0	0
	12	-0.04	4	0	0
	20	-0.01	11	0	0
	40	-0.01	21	0.02	0
	100	-0.41	67	0	0
<b>Sodium Cyanide</b>	0	0	0	0	0
	1	-0.47	0	0.44	0.13
	2	-0.47	1	0.58	0.27
	4	-0.37	4	0.96	0.6
	6	-0.37	8	1.05	1.01
	8	-0.36	15	1.08	1.21
	12	-0.36	26	1.21	1.86
	24	-0.36	50	1.53	3.65
<b>Sodium Fluoroacetate (1080)</b>	0	0	0	0	0
	1	0	4	-0.05	0.38
	4	-0.06	4	-0.15	1.52
	10	-0.13	10	-0.01	2.82
	20	-0.24	19	-0.13	5.88
	40	-0.32	35	0	10
	80	-0.41	66	0	10
<b>Aldicarb</b>	0	0	0	0	0
	1	-0.52	0	0	0.56
	2	-0.55	0	0	1.12
	5	-0.41	1	0	2.1
	10	-0.43	4	0	4.07
	20	-0.43	6	0	9.62
	40	-0.42	7	0	10

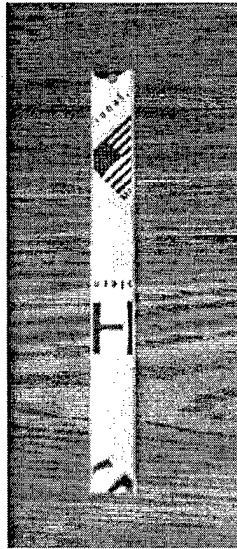
**APPENDIX D      BIOREACTOR AND BIOFILM DATA AND  
PICTURES**

Figures D-1 through D-7 display the lab equipment that was used to obtain the biofilm data. Figure D-1 shows the two distinct annular spaces in the bioreactor that are sealed off by o-rings located at both the top and bottom of the reactor.



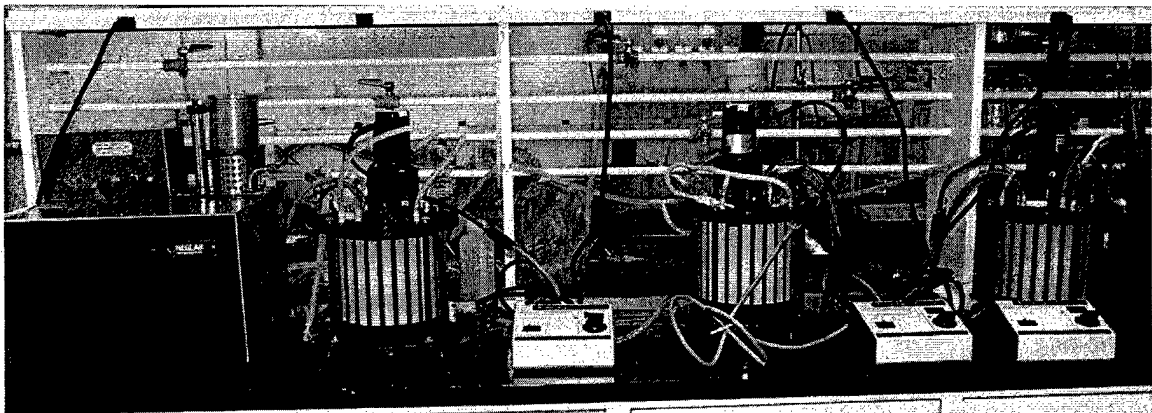
**Figure D-1** Top view of open bioreactor

Figure D-2 shows the PVC coupon that was used in the bioreactor. Before placement into the reactor, the mylar coating with the markings was removed. Twenty of these coupons were mounted on the reactor drum. The coupon measures  $5\frac{7}{8}$ " x  $5/8$ " for a surface area of  $3.67\text{ in}^2$ .



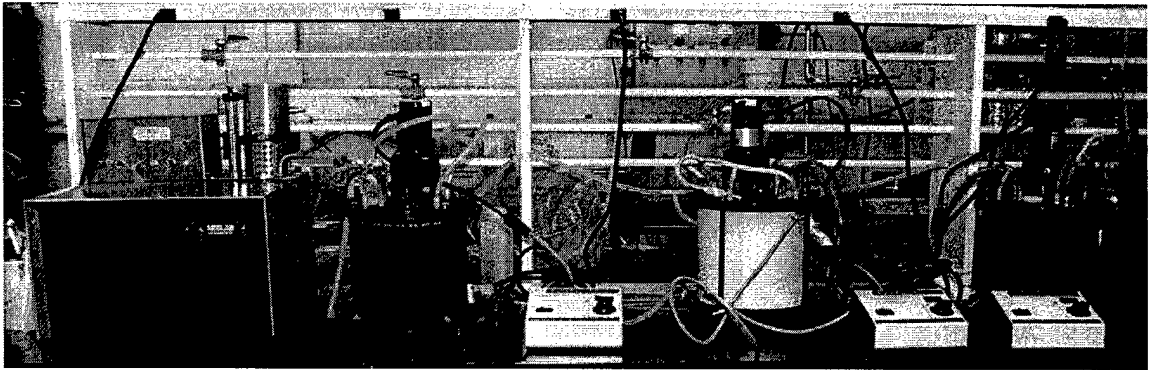
**Figure D-2** PVC coupon

Figure D-3 shows the three bioreactors and heat exchanger before the bioreactors were covered to prevent phototrophic growth on the coupons.



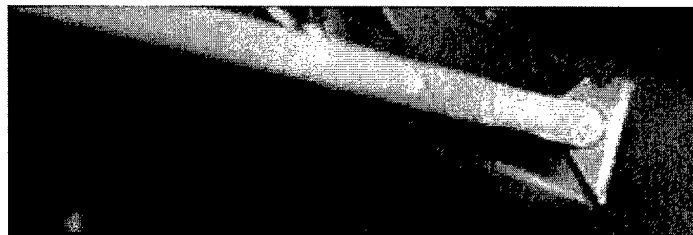
**Figure D-3** Uncovered bioreactors and heat exchanger setup

Figure D-4 shows the bioreactors covered during the growth phase of the biofilms on the coupons. As an added measure, every effort was made to keep the lights off in this room when not required for other lab work.



**Figure D-4** Covered bioreactors and heat exchanger setup

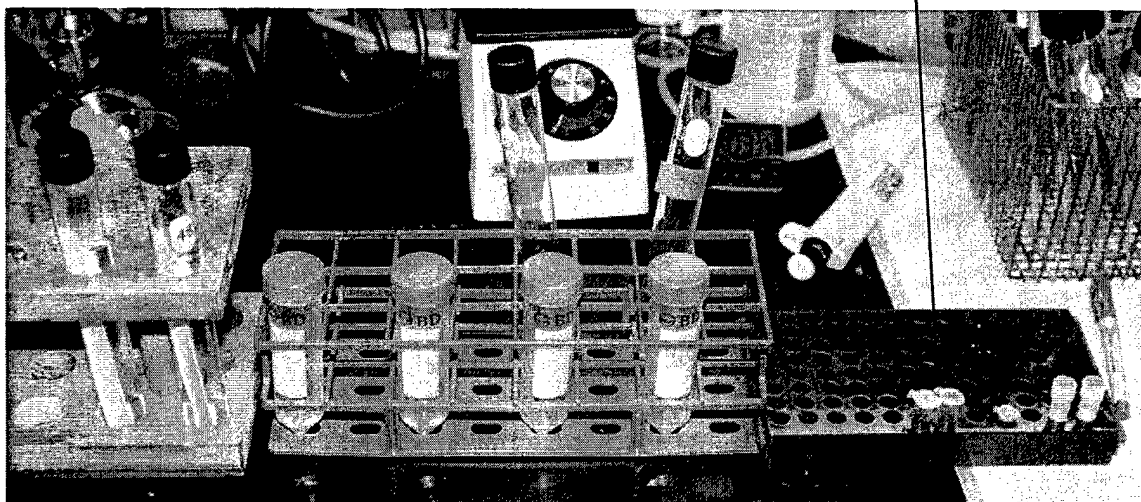
Figure D-5 displays the scraping tool that was used to remove the biofilm from the PVC coupons. These scraping tools were home made by Dr. Klein, autoclaved, used once, then disposed of.



**Figure D-5** Coupon scraper

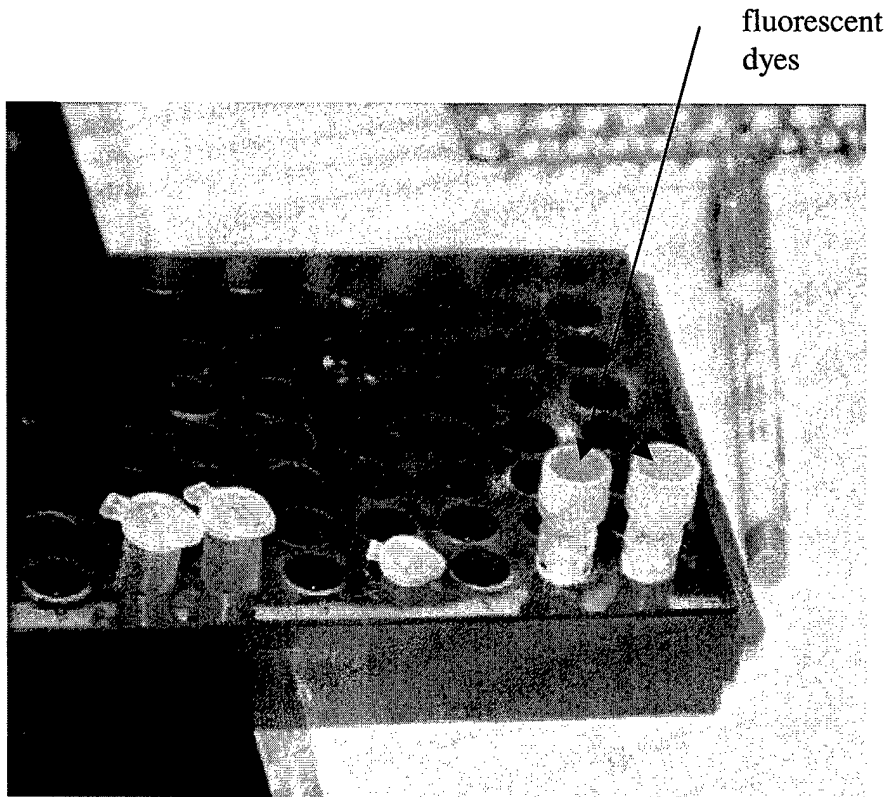
Figure D-6 shows the assembly of tubes that were used during the experiment. Looking closely, the PVC coupons are apparent in the 75 mL test tubes on the left. The coupons were scraped into solution in the test tube, then the solution was transferred into the blue capped 50 mL conical tubes to facilitate pipetting 1 mL of the biofilm solution into the 1.7 mL retention tubes.

1.7 mL  
retention tubes



**Figure D-6** Test tube apparatus used for cell counts

Figure D-7 is an enlarged view of the retention tubes, the two fluorescent dies that were used to determine viability, and the smaller tube that the dies were mixed in before being applied to the biofilm solution.



**Figure D-7** Retention tubes and fluorescent dyes used in cell counts

Table D-1 provides the raw cell count data that was generated to determine if pulling one coupon from the reactor at a time would be representative of other coupons in the reactor, or phrased another way, to determine if all coupons from the same reactor at the same time could be considered homogeneous.

**Table D-1 Cell count data from eight coupons to determine homogeneity**

Field	Coupon 1 5-Dec-03			Coupon 2 11-Dec-03			Coupon 3 11-Dec-03			Coupon 4 11-Dec-03		
	Live	Dead	Total	Live	Dead	Total	Live	Dead	Total	Live	Dead	Total
1	8	4	12	2	0	2	1	0	1	1	0	1
2	3	0	3	1	0	1	0	0	0	0	0	2
3	3	5	8	0	1	1	1	0	1	7	0	7
4	4	0	4	0	3	3	1	0	1	1	0	1
5	2	0	2	1	1	2	0	0	0	2	0	2
6	5	1	6	1	0	1	5	0	5	0	0	0
7	8	1	9	4	0	4	0	1	1	2	0	2
8	2	0	2	2	0	2	5	1	6	0	0	0
9	0	0	0	0	0	0	0	0	0	5	0	5
10	1	0	1	1	0	1	3	1	4	5	1	6
11	0	0	0	1	0	1	2	1	3	0	0	0
12	10	0	10	4	0	4	0	0	0	1	0	1
13	4	0	4	0	0	0	6	2	8	1	0	1
14	3	1	4	1	0	1	2	0	2	3	0	3
15	1	0	1	0	0	0	2	0	2	1	1	2
16	0	0	0	5	0	5	5	0	5	1	0	1
17	0	0	0	1	0	1	4	0	4	1	0	1
18	3	0	3	4	0	4	2	0	2	3	0	3
19	1	0	1	4	1	5	2	0	2	1	0	1
20	5	0	5	23	0	23	6	0	6	14	1	15
21	1	0	1	7	1	8	5	0	5	1	0	1
22	0	0	0	13	1	14	9	0	9	0	0	0
23	0	0	0	6	0	6	0	0	0	3	1	4
24	0	0	0	5	0	5	2	0	2	6	0	6
25	1	0	1	13	0	13	6	0	6	5	0	5
Avg	2.6	0.48	3.08	3.96	0.32	4.28	3.12	0.24	3.36	2.56	0.2	2.76

**Table D-1** Cell count data from eight coupons to determine homogeneity (cont'd)

Field	Coupon 5 11-Dec-03			Coupon 6 11-Dec-03			Coupon 7 11-Dec-03			Coupon 8		
	Live	Dead	Total	Live	Dead	Total	Live	Dead	Total	Live	Dead	Total
1	2	0	2	0	1	1	2	0	2	0	2	2
2	2	2	4	1	0	1	4	0	4	0	5	5
3	0	1	1	0	0	0	0	0	0	0	0	9
4	0	1	1	1	1	2	4	0	4	0	10	10
5	1	0	1	1	0	1	0	2	2	0	4	4
6	2	0	2	1	0	1	5	0	5	2	2	2
7	2	0	2	0	0	0	1	0	1	1	1	1
8	0	0	0	2	0	2	1	0	1	1	4	4
9	29	0	29	0	0	0	4	0	4	4	9	9
10	5	0	5	0	0	0	0	0	0	1	8	8
11	19	0	19	1	0	1	1	0	1	1	4	4
12	14	1	15	1	0	1	2	0	2	0	0	0
13	1	0	1	2	0	2	1	0	1	0	4	4
14	1	0	1	3	0	3	3	0	3	0	2	2
15	0	0	0	1	0	1	7	0	7	0	1	1
16	1	0	1	1	0	1	1	0	1	0	5	5
17	0	0	0	0	1	1	8	0	8	1	2	2
18	0	0	0	2	0	2	2	0	2	1	4	4
19	5	0	5	1	0	1	3	0	3	0	0	0
20	3	1	4	1	0	1	8	0	8	1	3	3
21	13	0	13	1	0	1	1	0	1	0	0	0
22	8	0	8	0	0	0	2	0	2	0	2	2
23	4	0	4	0	1	1	4	0	4	0	0	0
24	5	0	5	1	0	1	0	1	1	0	3	3
25	3	0	3	0	0	0	3	0	3	0	5	5
Avg	4.8	0.24	5.04	0.84	0.16	1	2.68	0.12	2.8	0.56	3.56	

Table D-2 summarizes the data in table D-1 and provides descriptive statistics that were used to determine the 95% confidence interval of the mean live cell count per field per coupon.

**Table D-2** Summary of cell counts per coupon from Table D-1 with descriptive statistics

Coupon	Live	Dead	Total
1	2.60	0.48	3.08
2	3.96	0.32	4.28
3	3.12	0.24	3.36
4	2.56	0.20	2.76
5	4.80	0.24	5.04
6	0.84	0.16	1.00
7	2.68	0.12	2.80
8	3	0.56	3.56
Avg	2.95	0.29	3.24
Std Dev	1.15	0.16	1.19
n	8		
df	7		
t(0.975,7)	2.365		
LL	1.98		
UL	3.91		

95% CI is 1.98, 3.91

Table D-3 provides the turbidity data that resulted from introduction of contaminants into the acclimated bioreactor. These experiments were conducted at the ERC.

**Table D-3** Bioreactor turbidity results

Contaminant	Concentration (mg/L)	Date	t=0 min		t <sub>reactor</sub> (min)			
			tap water	tap water + Contam	tap water	tap water + contaminant		
					0	1	8	48
Tap Water	N/A	2-Jan-04	0.13	N/A	0.28	0.47	0.44	0.39
Sodium Arsenate	15	5-Jan-04	0.42	0.45	0.86	3.34	3.69	3.07
	5	22-Jan-04	0.20	0.26	0.45	4.84	3.07	2.45
	1	4-Feb-04	0.26	0.31	0.57	3.31	2.8	2.23
Sodium Fluoroacetate (1080)	1	19-Feb-04	0.18	0.44	0.45	3.42	16.9	19.8
	0.5	4-Mar-04	0.40	0.19	0.82	1.74	1.78	1.68
Aldicarb	0.5	1-Apr-04	0.17	0.33	0.98	3.01	3.87	4.48
	0.25	15-Apr-04	0.15	0.18	1.13	9.28	9.68	9.32
Sodium Cyanide	0.5	29-Apr-04	0.14	0.15	0.19	1.42	1.27	1.21
	0.25	6-May-04	0.19	0.32	1.54	2.92	2.81	2.92

Tables D-4 through D-11 provide the raw cell count data that resulted from scraping off of the biofilm from the PVC coupons after being exposed for 0, 1, 8, or 48 minutes, adding fluorescent dies, then performing cell counts using fluorescence microscopy.

**Table D-4** Cell counts for biofilm exposed to 15 mg/L of sodium arsenate

NaArsenate 15 mg/L 6-Jan-04												
Field	T=0			T=1			T=8			T=48		
	Live	Dead	Total	Live	Dead	Total	Live	Dead	Total	Live	Dead	Total
1	8	0	8	3	0	3	0	0	0	3	0	3
2	8	0	8	5	0	5	0	0	0	4	0	4
3	1	0	1	2	0	2	0	0	0	12	0	12
4	3	0	3	2	0	2	0	0	0	2	0	2
5	12	0	12	3	0	3	0	0	0	5	0	5
6	15	0	15	0	0	0	1	0	1	0	0	0
7	1	0	1	2	0	2	0	0	0	2	1	3
8	10	0	10	1	0	1	0	0	0	1	0	1
9	7	0	7	1	0	1	2	0	2	2	0	2
10	9	0	9	1	0	1	0	0	0	1	0	1
11	4	0	4	0	0	0	2	0	2	0	0	0
12	2	0	2	2	0	2	3	0	3	3	0	3
13	2	0	2	2	0	2	1	0	1	2	0	2
14	0	0	0	3	0	3	2	0	2	0	0	0
15	2	0	2	2	0	2	0	0	0	0	0	0
16	2	0	2	1	0	1	0	0	0	3	0	3
17	0	0	0	1	0	1	0	0	0	0	0	0
18	3	0	3	1	0	1	0	0	0	0	0	0
19	1	0	1	1	0	1	0	0	0	0	0	0
20	4	0	4	1	0	1	0	0	0	0	1	1
21	4	0	4	0	0	0	1	0	1	1	2	3
22	4	0	4	4	0	4	1	0	1	0	1	1
23	2	0	2	0	1	1	7	0	7	2	0	2
24	3	0	3	0	0	0	0	0	0	0	0	0
25	4	1	5	0	0	0	0	0	0	4	0	4
Avg	4.44	0.04	4.48	1.52	0.04	1.56	0.8	0	0.8	1.88	0.2	2.08

**Table D-5** Cell counts for biofilm exposed to 5 mg/L of sodium arsenate

Field	NaArsenate 5 mgL 23-Jan-04											
	T=0			T=1			T=8			T=48		
	Live	Dead	Total	Live	Dead	Total	Live	Dead	Total	Live	Dead	Total
1	1	0	1	1	0	1	2	0	2	1	0	1
2	9	0	9	3	0	3	0	0	0	1	0	1
3	1	0	1	2	0	2	0	0	0	0	0	0
4	1	0	1	1	0	1	0	0	0	0	1	1
5	0	0	0	2	0	2	0	0	0	1	0	1
6	1	0	1	1	0	1	1	0	1	0	0	0
7	0	0	0	0	0	0	0	0	0	0	0	0
8	1	0	1	1	0	1	0	0	0	0	0	0
9	1	0	1	2	0	2	1	0	1	1	0	1
10	0	0	0	2	0	2	1	1	2	0	0	0
11	1	2	3	7	0	7	2	0	2	14	0	14
12	1	0	1	1	0	1	11	0	11	9	0	9
13	0	0	0	2	0	2	3	0	3	0	0	0
14	1	0	1	2	0	2	4	1	5	1	0	1
15	15	0	15	2	0	2	9	0	9	0	0	0
16	14	0	14	1	0	1	0	0	0	0	0	0
17	5	0	5	3	0	3	0	0	0	0	0	0
18	8	0	8	2	0	2	1	0	1	0	0	0
19	3	0	3	6	0	6	1	0	1	0	0	0
20	6	0	6	4	0	4	0	0	0	2	0	2
21	10	0	10	3	0	3	0	0	0	20	0	20
22	4	0	4	1	0	1	5	1	6	3	0	3
23	9	0	9	5	0	5	4	0	4	6	0	6
24	1	0	1	2	0	2	5	0	5	1	0	1
25	0	0	0	7	0	7	3	1	4	6	1	7
Avg	3.7	0.1	3.8	2.5	0.0	2.5	2.1	0.2	2.3	2.6	0.1	2.7

**Table D-6** Cell counts for biofilm exposed to 1 mg/L of sodium fluoroacetate (1080)

Field	1080 1 mgL						20-Feb-04					
	T=0			T=1			T=8			T=48		
	Live	Dead	Total	Live	Dead	Total	Live	Dead	Total	Live	Dead	Total
1	5	0	5	0	0	0	1	0	1	0	0	0
2	0	0	0	0	0	0	0	1	1	0	1	1
3	0	0	0	0	0	0	2	0	2	0	0	0
4	0	0	0	0	0	0	1	0	1	0	0	0
5	0	0	0	0	0	0	1	0	1	0	0	0
6	0	0	0	0	0	0	0	0	0	0	0	0
7	1	0	1	5	0	5	0	1	1	1	0	1
8	0	0	0	0	0	0	0	0	0	1	0	1
9	4	0	4	0	0	0	0	0	0	0	0	0
10	1	0	1	0	0	0	0	0	0	0	1	1
11	1	0	1	0	0	0	0	0	0	0	0	0
12	0	0	0	0	0	0	3	0	3	0	0	0
13	0	0	0	0	0	0	2	0	2	0	0	0
14	0	0	0	0	0	0	0	0	0	0	0	0
15	0	0	0	0	0	0	0	0	0	0	0	0
16	0	0	0	1	0	1	0	0	0	0	0	0
17	1	0	1	0	0	0	0	0	0	0	0	0
18	0	0	0	0	0	0	0	0	0	0	0	0
19	0	0	0	0	0	0	0	0	0	0	1	1
20	0	0	0	0	0	0	0	0	0	0	1	1
21	2	0	2	0	0	0	0	0	0	0	0	0
22	0	0	0	1	0	1	1	1	2	0	0	0
23	0	0	0	0	0	0	0	0	0	0	0	0
24	0	0	0	0	0	0	0	0	0	0	0	0
25	0	0	0	2	0	2	0	0	0	0	0	0
<b>Avg</b>	<b>0.60</b>	<b>0.00</b>	<b>0.60</b>	<b>0.36</b>	<b>0.00</b>	<b>0.36</b>	<b>0.44</b>	<b>0.12</b>	<b>0.56</b>	<b>0.08</b>	<b>0.16</b>	<b>0.24</b>

**Table D-7** Cell counts for biofilm exposed to 0.5 mg/L of sodium fluoroacetate (1080)

Field	1080 0.5 mg/L									5-Mar-04		
	T=0			T=1			T=8			T=48		
	Live	Dead	Total	Live	Dead	Total	Live	Dead	Total	Live	Dead	Total
1	1	0	1	0	2	2	5	0	5	0	0	0
2	6	0	6	0	0	0	0	0	0	0	0	0
3	5	0	5	0	3	3	4	0	4	0	0	0
4	9	1	10	3	0	3	0	0	0	0	0	0
5	5	0	5	2	0	2	0	0	0	0	0	0
6	0	0	0	0	7	7	0	0	0	0	0	0
7	0	0	0	3	0	3	3	0	3	0	0	0
8	0	0	0	1	0	1	0	0	0	0	0	0
9	0	0	0	0	0	0	0	0	0	0	0	0
10	0	0	0	0	0	0	0	0	0	0	0	0
11	0	0	0	0	0	0	1	0	1	0	0	0
12	0	0	0	0	0	0	0	0	0	0	0	0
13	0	0	0	0	0	0	0	1	1	0	0	0
14	3	1	4	0	0	0	0	0	0	0	0	0
15	0	0	0	0	0	0	0	0	0	0	0	0
16	3	0	3	0	0	0	1	0	1	0	0	0
17	1	0	1	0	0	0	0	0	0	0	0	0
18	1	0	1	0	0	0	0	0	0	0	0	0
19	0	0	0	0	0	0	3	0	3	0	0	0
20	4	0	4	0	0	0	0	0	0	0	0	0
21	1	0	1	0	0	0	0	0	0	0	0	0
22	0	0	0	0	0	0	0	0	0	0	0	0
23	5	0	5	0	0	0	0	0	0	0	0	0
24	0	0	0	0	0	0	0	0	0	0	0	0
25	0	0	0	0	0	0	0	0	0	0	0	0
<b>Avg</b>	1.76	0.08	1.84	0.36	0.48	0.84	0.68	0.04	0.72	0.00	0.00	0.00

**Table D-8** Cell counts for biofilm exposed to 0.5 mg/L of aldicarb

Field	Aldicarb 0.5 mgL 2-Apr-04											
	T=0			T=1			T=8			T=48		
	Live	Dead	Total	Live	Dead	Total	Live	Dead	Total	Live	Dead	Total
1	4	1	5	2	0	2	1	0	1	0	1	1
2	5	1	6	1	0	1	0	0	0	0	0	0
3	0	0	0	0	0	0	0	0	0	0	0	0
4	0	0	0	0	0	0	0	0	0	0	0	0
5	3	0	3	0	0	0	0	0	0	0	0	0
6	2	0	2	0	0	0	0	0	0	0	0	0
7	0	0	0	1	0	1	0	0	0	0	0	0
8	0	0	0	1	0	1	0	0	0	0	0	0
9	0	0	0	0	0	0	0	0	0	0	0	0
10	1	0	1	1	0	1	0	0	0	0	0	0
11	2	0	2	0	0	0	0	0	0	0	0	0
12	2	0	2	0	0	0	0	0	0	0	0	0
13	0	0	0	0	0	0	0	0	0	5	2	7
14	3	0	3	0	0	0	0	0	0	0	0	0
15	1	0	1	0	0	0	0	0	0	1	0	1
16	2	0	2	0	0	0	0	0	0	0	0	0
17	4	0	4	0	0	0	0	0	0	0	0	0
18	1	1	2	1	0	1	0	0	0	1	0	1
19	0	0	0	0	0	0	0	0	0	0	0	0
20	0	0	0	2	0	2	0	0	0	0	0	0
21	3	0	3	2	0	2	0	0	0	0	0	0
22	3	0	3	4	0	4	0	0	0	0	0	0
23	4	1	5	1	0	1	1	0	1	0	0	0
24	0	0	0	2	0	2	0	0	0	0	0	0
25	1	0	1	0	0	0	0	0	0	0	0	0
<b>Avg</b>	<b>1.64</b>	<b>0.16</b>	<b>1.80</b>	<b>0.72</b>	<b>0.00</b>	<b>0.72</b>	<b>0.08</b>	<b>0.00</b>	<b>0.08</b>	<b>0.28</b>	<b>0.12</b>	<b>0.40</b>

**Table D-9** Cell counts for biofilm exposed to 0.25 mg/L of aldicarb

Field	Aldicarb 0.25 mg/L 16-Apr-04											
	T=0			T=1			T=8			T=48		
	Live	Dead	Total	Live	Dead	Total	Live	Dead	Total	Live	Dead	Total
1	2	0	2	0	3	3	0	1	1	0	0	0
2	4	0	4	0	0	0	3	0	3	0	0	0
3	1	0	1	0	0	0	0	0	0	0	0	0
4	1	0	1	3	0	3	0	0	0	0	0	0
5	1	0	1	0	0	0	0	0	0	0	0	0
6	1	0	1	1	0	1	0	0	0	2	0	2
7	1	0	1	2	0	2	0	0	0	0	0	0
8	3	0	3	0	0	0	0	0	0	0	0	0
9	3	0	3	0	0	0	0	0	0	0	0	0
10	1	0	1	1	0	1	0	0	0	0	0	0
11	3	0	3	1	0	1	0	0	0	0	0	0
12	2	0	2	2	0	2	0	0	0	0	0	0
13	1	0	1	0	0	0	1	0	1	0	0	0
14	2	0	2	0	0	0	0	0	0	0	0	0
15	3	0	3	0	0	0	0	0	0	0	0	0
16	1	0	1	1	0	1	0	0	0	0	0	0
17	0	0	0	0	0	0	0	0	0	0	0	0
18	0	0	0	0	0	0	0	0	0	1	0	1
19	1	0	1	0	0	0	0	0	0	0	0	0
20	3	0	3	0	1	1	0	0	0	1	0	1
21	0	0	0	0	0	0	0	0	0	0	0	0
22	0	0	0	0	0	0	0	0	0	0	0	0
23	1	0	1	0	0	0	0	0	0	0	0	0
24	1	0	1	2	0	2	0	0	0	0	0	0
25	0	0	0	0	0	0	0	0	0	0	0	0
<b>Avg</b>	<b>1.44</b>	<b>0.00</b>	<b>1.44</b>	<b>0.52</b>	<b>0.16</b>	<b>0.68</b>	<b>0.16</b>	<b>0.04</b>	<b>0.20</b>	<b>0.16</b>	<b>0.00</b>	<b>0.16</b>

**Table D-10** Cell counts for biofilm exposed to 0.5 mg/L of sodium cyanide

Field	NaCN 0.5 mg/L 30-Apr-04											
	T=0			T=1			T=8			T=48		
	Live	Dead	Total	Live	Dead	Total	Live	Dead	Total	Live	Dead	Total
1	5	0	5	6	0	6	0	1	1	0	0	0
2	3	0	3	3	2	5	0	1	1	0	0	0
3	0	0	0	3	2	5	1	0	1	0	0	0
4	0	0	0	2	2	4	0	0	0	0	0	0
5	0	0	0	1	4	5	0	0	0	0	0	0
6	1	0	1	1	4	5	0	0	0	0	0	0
7	1	0	1	1	2	3	0	0	0	0	0	0
8	0	0	0	3	1	4	0	0	0	0	0	0
9	2	0	2	0	3	3	0	0	0	0	0	0
10	2	0	2	2	4	6	0	0	0	0	0	0
11	0	0	0	0	6	6	0	0	0	0	0	0
12	1	0	1	0	2	2	0	0	0	0	0	0
13	1	0	1	3	0	3	0	0	0	0	0	0
14	2	0	2	3	5	8	1	0	1	0	0	0
15	1	0	1	0	4	4	0	0	0	0	0	0
16	3	0	3	3	3	6	0	0	0	0	0	0
17	1	0	1	0	1	1	0	0	0	0	0	0
18	2	0	2	3	0	3	0	0	0	0	0	0
19	3	0	3	0	3	3	0	0	0	0	0	0
20	0	0	0	1	0	1	0	0	0	0	0	0
21	0	0	0	0	3	3	0	0	0	0	0	0
22	1	0	1	1	1	2	0	0	0	0	0	0
23	1	0	1	2	4	6	0	0	0	0	0	0
24	3	0	3	1	3	4	0	0	0	0	0	0
25	2	0	2	2	1	3	0	0	0	0	0	0
<b>Avg</b>	<b>1.40</b>	<b>0.00</b>	<b>1.40</b>	<b>1.64</b>	<b>2.40</b>	<b>4.04</b>	<b>0.08</b>	<b>0.08</b>	<b>0.16</b>	<b>0.00</b>	<b>0.00</b>	<b>0.00</b>

**Table D-11** Cell counts for biofilm exposed to 0.25 mg/L of sodium cyanide

Field	NaCN 0.25 mg/L 7-May-04											
	T=0			T=1			T=8			T=48		
	Live	Dead	Total	Live	Dead	Total	Live	Dead	Total	Live	Dead	Total
1	1	0	1	2	0	2	0	0	0	0	0	0
2	5	0	5	0	0	0	0	0	0	0	0	0
3	3	0	3	3	0	3	1	0	1	0	0	0
4	3	0	3	2	0	2	0	0	0	0	0	0
5	3	0	3	1	0	1	0	0	0	0	0	0
6	2	0	2	3	1	4	0	0	0	0	0	0
7	0	0	0	1	0	1	0	0	0	0	0	0
8	0	0	0	0	0	0	0	0	0	0	0	0
9	1	0	1	0	0	0	0	0	0	0	0	0
10	1	0	1	0	0	0	0	0	0	0	0	0
11	2	0	2	2	0	2	0	0	0	0	0	0
12	2	0	2	1	0	1	0	0	0	0	0	0
13	1	0	1	0	0	0	0	0	0	0	0	0
14	0	0	0	2	0	2	0	0	0	0	0	0
15	1	0	1	1	0	1	0	0	0	0	0	0
16	2	0	2	6	0	6	0	0	0	0	1	1
17	2	0	2	2	0	2	0	0	0	0	0	0
18	3	0	3	0	0	0	0	0	0	0	0	0
19	1	0	1	0	0	0	0	0	0	0	0	0
20	1	0	1	1	0	1	0	0	0	0	0	0
21	1	0	1	0	0	0	0	0	0	0	0	0
22	1	0	1	1	0	1	0	0	0	0	0	0
23	1	0	1	0	0	0	0	0	0	0	0	0
24	0	0	0	0	0	0	0	0	0	0	0	0
25	1	0	1	0	0	0	0	0	0	0	0	0
<b>Avg</b>	<b>1.52</b>	<b>0.00</b>	<b>1.52</b>	<b>1.12</b>	<b>0.04</b>	<b>1.16</b>	<b>0.04</b>	<b>0.00</b>	<b>0.04</b>	<b>0.00</b>	<b>0.04</b>	<b>0.04</b>

Table D-12 summarizes the live cell count data in tables D-4 through D-11.

**Table D-12** Summary of live cell counts for biofilm per exposure

Contaminant	Concentration (mg/L)	Exposure time to contaminant, t (min)			
		0	1	8	48
Sodium Arsenate	15	4.44	1.52	0.8	1.88
	5	3.7	2.5	2.1	2.6
Sodium Fluoroacetate (1080)	1	0.60	0.36	0.44	0.08
	0.5	1.76	0.36	0.68	0
Aldicarb	0.5	1.64	0.72	0.08	0.28
	0.25	1.44	0.52	0.16	0.16
Sodium Cyanide	0.5	1.40	1.64	0.08	0
	0.25	1.52	1.12	0.04	0

Table D-13 provides the log removal of cells per contaminant concentration and exposure time in the reactor. A negative value seen near the bottom of the table for sodium cyanide indicates that there were more cells on the coupon that was exposed to sodium cyanide for one-minute than there were on the coupon that was not exposed to sodium cyanide. This may be explained by the fact that not all coupon cell counts per reactor are homogeneous. What likely took place is that the t=0 coupon had relatively few live cells on the coupon, and the t=1 minute coupon had significantly more live cells on its coupon.

**Table D-13** Summary of log removal of cells per exposure

Contaminant	Concentration (mg/L)	Exposure time to contaminant, t (min)		
		1	8	48
Sodium Arsenate	15	0.47	0.74	0.37
	5	0.17	0.25	0.15
Sodium Fluoroacetate (1080)	1	0.22	0.13	0.88
	0.5	0.69	0.41	*
Aldicarb	0.5	0.36	1.31	0.77
	0.25	0.44	0.95	0.95
Sodium Cyanide	0.5	-0.07	1.24	*
	0.25	0.13	1.58	*

\* Cell counts were zero, making log removals incalculable

## **APPENDIX E    CLUSTER ANALYSIS**

Table E-1 provides the cluster averages for all water quality parameters per contaminant concentration. As can be seen in the table, conductivity seemed to provide the largest difference between cluster means in almost every case, making it easy to understand why conductivity had such an effect on defining the clusters that the data were assigned to, and in most cases, offering a quicker detection time than the 'sensitive' parameter as highlighted in Table 5-1. Because the data was not pre-processed before being run through the k-means algorithm, the impact that conductivity had may be easy to challenge because as a parameter, it had significantly larger values (close to 120), and had the most variation and largest range. Pre-processing would likely eliminate these factors and reduce the impact that conductivity has on the cluster results.

**Table E-1 Cluster averages per contaminant and concentration**

Contaminant	Concentration (mg/L)	Chlorine Residual (mg/L)			Conductivity (uS/cm)			pH		
		Cluster 1	Cluster 2	Δ	Cluster 1	Cluster 2	Δ	Cluster 1	Cluster 2	Δ
Sodium Arsenate	15	0.594	0.589	0.005	115.521	116.009	0.488	7.826	7.829	0.003
	25	0.568	0.569	0.001	117.194	116.236	0.958	7.855	7.856	0.001
	50	0.480	0.489	0.010	116.547	115.692	0.855	7.782	7.780	0.002
	100	0.640	0.638	0.001	116.926	115.464	1.463	7.762	7.760	0.002
Sodium Cyanide	0.5	0.835	0.823	0.013	115.544	114.870	0.674	7.931	7.936	0.004
	1	0.661	0.582	0.079	116.218	117.096	0.879	7.704	7.702	0.002
	3	0.526	0.495	0.031	114.765	115.235	0.470	7.860	7.863	0.002
	5	0.337	0.494	0.157	120.487	118.693	1.794	7.894	7.881	0.013
	10	0.502	0.488	0.013	120.227	118.998	1.228	7.690	7.728	0.038
Sodium Fluoroacetate 1080	3	0.486	0.482	0.004	113.844	114.556	0.712	7.888	7.880	0.008
	5	0.434	0.435	0.001	120.795	120.551	0.244	7.748	7.748	0.000
	10	0.508	0.494	0.014	117.061	118.053	0.992	7.758	7.771	0.013
Aldicarb	1	0.670	0.676	0.006	116.263	115.541	0.722	7.740	7.744	0.004
	3	0.558	0.496	0.062	117.706	118.502	0.796	7.872	7.862	0.010
	5	0.466	0.458	0.009	118.510	119.231	0.721	7.820	7.808	0.012
	10	0.604	0.296	0.309	117.525	117.766	0.242	7.711	7.788	0.077

**Table E-1 Cluster averages per contaminant and concentration (cont'd)**

Contaminant	Concentration (mg/L)	TOC (mg/L)		Δ	Turbidity (NTU)		Δ	Laser Turb (mg/L)		Δ
		Cluster 1	Cluster 2		Cluster 1	Cluster 2		Cluster 1	Cluster 2	
Sodium Arsenate	15	1.331	1.328	0.003	0.154	0.159	0.005	0.160	0.161	0.002
	25	1.828	1.814	0.014	0.176	0.168	0.008	0.146	0.143	0.003
	50	1.795	1.801	0.006	0.207	0.203	0.005	0.192	0.168	0.024
	100	1.755	1.762	0.007	0.183	0.168	0.015	0.151	0.139	0.012
Sodium Cyanide	0.5	1.179	1.185	0.005	0.115	0.119	0.005	0.081	0.079	0.002
	1	1.353	1.341	0.012	0.132	0.181	0.049	0.199	0.369	0.170
	3	1.545	1.538	0.007	0.131	0.133	0.002	0.111	0.112	0.001
	5	1.585	1.613	0.027	0.161	0.134	0.026	0.134	0.113	0.021
	10	1.745	1.747	0.002	0.125	0.125	0.000	0.100	0.108	0.008
Sodium Fluoroacetate 1080	3	1.469	1.428	0.041	0.157	0.135	0.023	0.185	0.226	0.041
	5	1.813	1.811	0.002	0.133	0.132	0.001	0.109	0.107	0.002
	10	1.782	1.877	0.095	0.113	0.123	0.010	0.096	0.104	0.008
Aldicarb	1	1.239	1.244	0.005	0.123	0.143	0.020	0.086	0.094	0.008
	3	1.762	1.790	0.028	0.133	0.140	0.008	0.100	0.119	0.019
	5	1.803	1.784	0.019	0.187	0.148	0.039	0.127	0.112	0.015
	10	1.774	2.155	0.381	0.132	0.189	0.056	0.114	0.140	0.026

The k-means algorithm assigned the cluster number randomly, so cluster 1 is not necessarily the “normal” cluster, and cluster 2 is not always the “contaminant” cluster. Generally, if the cluster assignments were plotted in a time-series, the cluster assignment from t=0 to t=100 would be the “normal” cluster.

The following code was used in Matlab v6.5 to plot the bivariate figures and to conduct the cluster assignments. The first set of code generated figures 5-4 through 5-7, the second set of code classified the data into clusters and provided some additional graphical analysis.

### Bivariate Figure Code

```
figure(1);
gplotmatrix(A10803cluster, [], A10803BC, [], 'xo');
figure(2);
gplotmatrix(Ald1Cluster, [], Ald1BC, [], 'xo');
figure(3);
gplotmatrix(Ars15Cluster, [], Ars15BC, [], 'xo');
figure(4);
gplotmatrix(NaCN1Cluster, [], NaCN1BC, [], 'xo');
```

### Cluster Assignment Code

```
a=A10803cluster;           %Includes baseline and cotaminant data
x=kmeans(a,2);            %Place data into two clusters
figure(1);
b=A10803tAll;
plot(b,x,'o')             %Plots t versus cluster assignment
xlabel('time')
ylabel('cluster')
title('1080 3 mg/L')
axis([0 200 ,0 3]);
```