



American Carbon Society

HOW WELL DOES CARBON HANDLE STRESS?

A BRIEF OVERVIEW OF CARBONS IN STRUCTURAL APPLICATIONS



**PLENARY LECTURE
CARBON2004**

**Dr. Wesley P. Hoffman
Air Force Research Laboratory**

Report Documentation Page

Form Approved
OMB No. 0704-0188

Public reporting burden for the collection of information is estimated to average 1 hour per response, including the time for reviewing instructions, searching existing data sources, gathering and maintaining the data needed, and completing and reviewing the collection of information. Send comments regarding this burden estimate or any other aspect of this collection of information, including suggestions for reducing this burden, to Washington Headquarters Services, Directorate for Information Operations and Reports, 1215 Jefferson Davis Highway, Suite 1204, Arlington VA 22202-4302. Respondents should be aware that notwithstanding any other provision of law, no person shall be subject to a penalty for failing to comply with a collection of information if it does not display a currently valid OMB control number.

1. REPORT DATE 09 JUN 2004	2. REPORT TYPE	3. DATES COVERED -	
4. TITLE AND SUBTITLE How Well Does Carbon Handle Stress?-An Overview of Structural Carbons		5a. CONTRACT NUMBER	
		5b. GRANT NUMBER	
		5c. PROGRAM ELEMENT NUMBER	
6. AUTHOR(S) Wesley Hoffman		5d. PROJECT NUMBER 2306	
		5e. TASK NUMBER M1B3	
		5f. WORK UNIT NUMBER 2306M1B3	
7. PERFORMING ORGANIZATION NAME(S) AND ADDRESS(ES) Air Force Research Laboratory (AFMC),AFRL/PRS,5 Pollux Drive,Edwards AFB,CA,93524-7048		8. PERFORMING ORGANIZATION REPORT NUMBER	
9. SPONSORING/MONITORING AGENCY NAME(S) AND ADDRESS(ES)		10. SPONSOR/MONITOR'S ACRONYM(S)	
		11. SPONSOR/MONITOR'S REPORT NUMBER(S)	
12. DISTRIBUTION/AVAILABILITY STATEMENT Approved for public release; distribution unlimited			
13. SUPPLEMENTARY NOTES The original document contains color images.			
14. ABSTRACT Attempt to give an overview that provides a flavor for the breadth of structural applications. Note that many times other properties, such as thermal-shock resistance, conductivity, etc. will also be required for application. Will not be all-inclusive Polycrystalline forms, sintered mesophase, and carbon fiber reinforced composites will be covered in some detail but nanocarbons will not be included. Many groups are working on reinforcement, thread, ropes, and nanocomposites. These are being covered in this meeting and apart from a few examples, such as, Hyperion and Applied Sciences have not yet been commercialized. They will be a subject for a future meeting.			
15. SUBJECT TERMS			
16. SECURITY CLASSIFICATION OF:			17. LIMITATION OF ABSTRACT
a. REPORT unclassified	b. ABSTRACT unclassified	c. THIS PAGE unclassified	
			18. NUMBER OF PAGES 53
			19a. NAME OF RESPONSIBLE PERSON



Scope Of Presentation



Attempt to give an overview that provides a flavor for the breadth of structural applications.

Note that many times other properties, such as thermal-shock resistance, conductivity, etc. will also be required for application.

Will not be all-inclusive

Polycrystalline forms, sintered mesophase, and carbon fiber reinforced composites will be covered in some detail but nanocarbons will not be included.

Many groups are working on reinforcement, thread, ropes, and nanocomposites. These are being covered in this meeting and apart from a few examples, such as, Hyperion and Applied Sciences have not yet been commercialized. They will be a subject for a future meeting.



Carbons Can Be Tailored To Possess A Wide Variety Of Properties



CARBON CAN

be lubricating --graphite powder & seals ...or abrasive--diesel soot

have high surface area--activated carbon (2000 m²/g)...or low--fibers (0.5 m²/g)

be hydrophobic--carbon surface...or hydrophilic--oxygenated carbon surface

be porous--activated carbon...or nonporous--HOPG

have high thermal conductivity--HOPG- (a-direction) or pitch fiber...or low thermal conductivity--HOPG (c-direction) or PAN Fiber

be anisotropic--graphite or HOPGor isotropic--polycrystalline graphite

be hard -- diamonds or chars...or soft-- carbon blacks

be strong-- PAN fibers... or weak--aerogel

be stiff—pitch carbon fibers...or flexible--Grafoil



What Do All These Things Have In Common??



Sintering Furnace

Satellite Structures

Fission And Fusion Reactors

High Temp. Furnace Hardware

Nuclear Fuel Particle Coatings

Golf Clubs And Tennis Rackets

Tanks And Pressure Vessels

Planes, Trains, And Automobiles

Steel And Aluminum Production

Rocket Motor Nozzles And Exit Cones

Leading Edges of Hypersonic Craft

Clutches

Nuts And Bolts

Highway Bridges

Heart Valves

Pistons

Bearing Cages

Artificial Joints

ICBM Nose Tips

Motorcycles

Turbine Blades

Brakes



Structural Properties

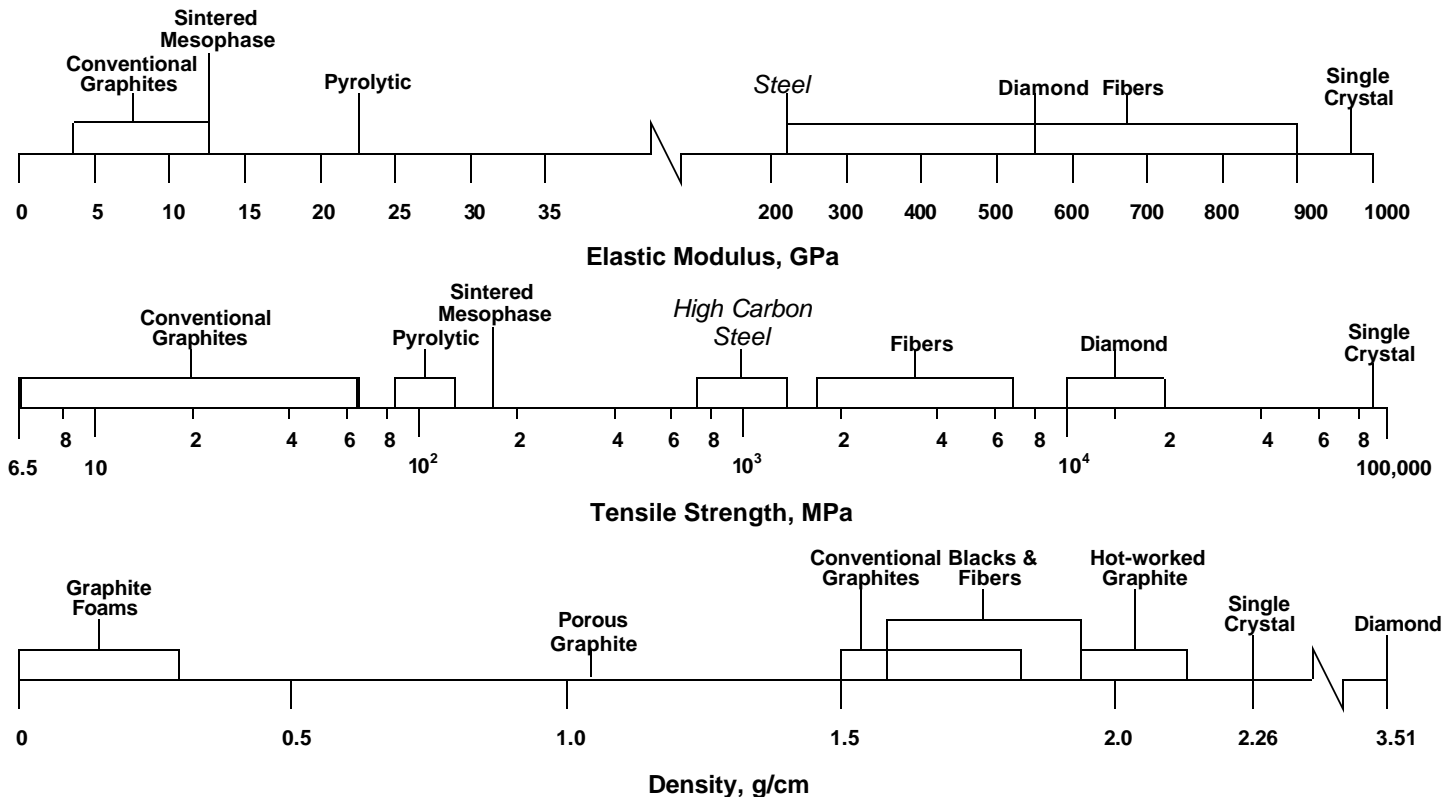



American Carbon Society

POLYCRYSTALLINE GRAPHITE



Approved for public release; distribution unlimited



Carbon Electrodes



The electrodes for the steel and aluminum industries can weigh up to two tons and must support their own weight. Electrodes in center are 30" in diameter by 110" long. On left diameter is 20" while on right it is 24"

Carbon electrodes are usually extruded from a mixture of petroleum coke and coal tar pitch binder and are used for the Aluminum, Steel, Magnesium, Fluorine, Chlorine, Sodium, and Uranium Industries.



Graphite Electrodes Electric arc Furnace

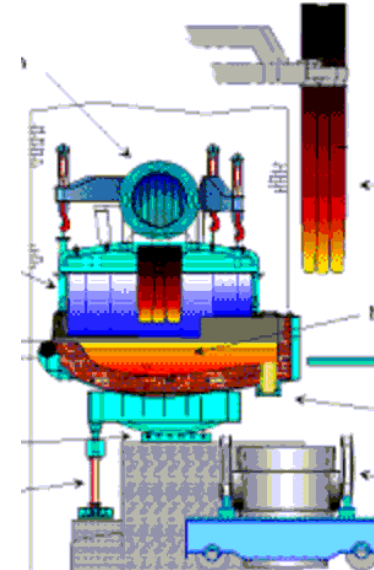
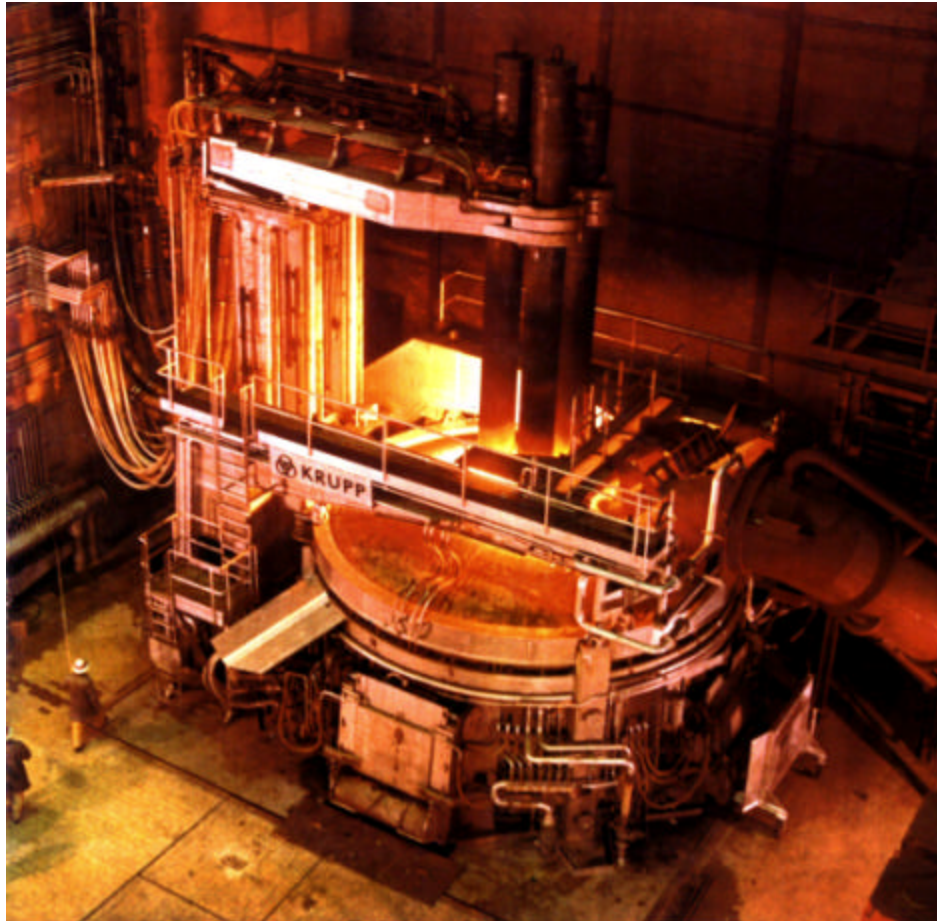

Graphite electrodes are used to reduce iron and make steel. (24" diameter shown)

Also, It requires one pound of carbon to reduce bauxite ore and produce two pounds of aluminum.



Chicago Pile One



- **First sustained nuclear reaction at the University of Chicago in December 1942 produced half a watt. Pile consisted of 57 layers of graphite blocks, half of them seeded with uranium.**



1160 MW Reactor

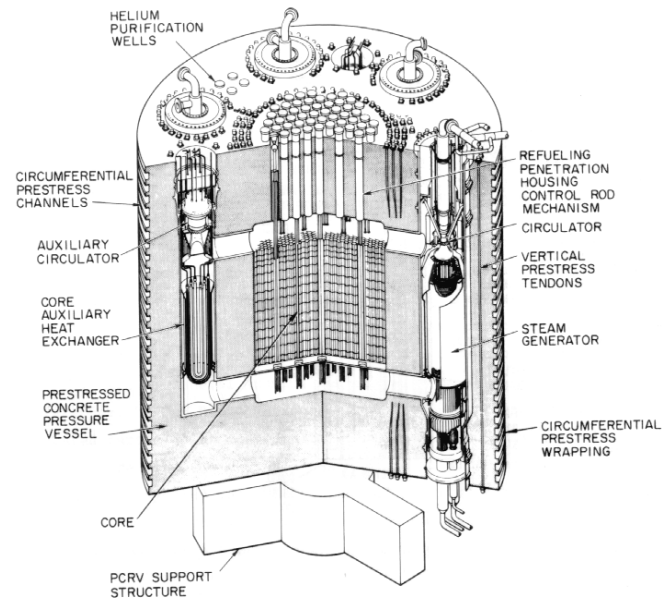

- **Carbon plays an essential role in the high temperature gas-cooled nuclear reactor. It serves as moderator, structural material, and as a fuel particle coating.**



American Carbon Society

PYROLYTIC GRAPHITE



Approved for public release; distribution unlimited



Pyrolytic Carbon



- **As the name implies, this carbon is formed through the cracking or pyrolysis of hydrocarbons.**

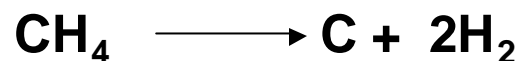

- **Carbon has a bad name in some fields because in the chemical field (especially in petroleum cracking) it is an undesirable by-product that must be burned away.**
- **However, this process utilizing principally methane and propylene for making carbon is important in the manufacture of HOPG, composites, nuclear fuel particles, and in the biomedical field**



Nuclear Fuel Particle

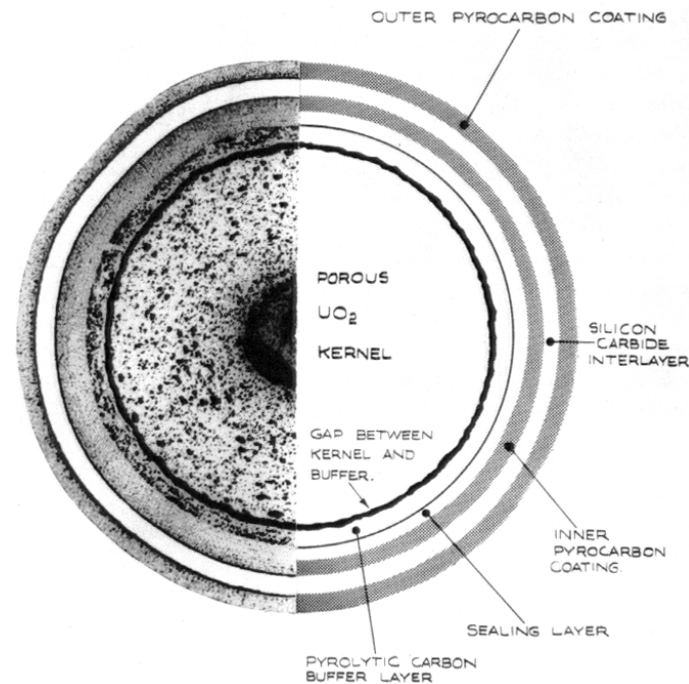

- **Photomicrograph of equatorial section of typical UO₂-coated particle and designation of the components of the particle. Note inner porous carbon layer and impervious outer layer**



Prosthetic Heart Valves



A tissue valve known as a xenograft, is a biological valve that has been taken from an animal heart (pig or cow)-- naturally biocompatible.

Mechanical heart valves are more durable and should last a lifetime but requires that the recipient take anticoagulation medicine (blood thinner) daily. Accounts for 60% of market.

The three principal mechanical designs are the Bileaflet, the Caged Ball, and the Tilting Disc

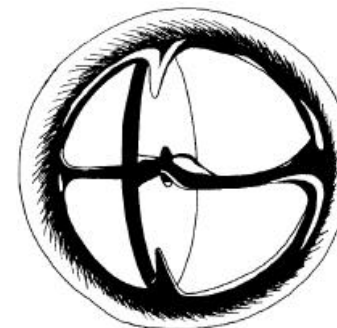



Prosthetic Heart Valves

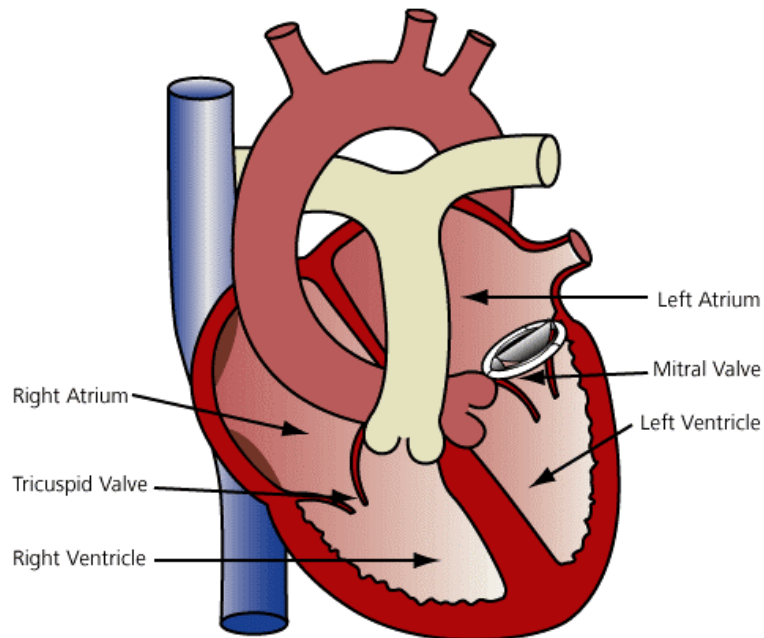

Pyrolytic carbon is the preferred (5 million to date) material for the exterior surfaces of valves because of its hardness, strength, durability, and because it is hard for blood components to stick to the valve. Interior is usually Poco® graphite (isotropic, therm. exp.) or tungsten (radio-opaque).



Prosthetic Joints



The Ascension[®] MCP is a two-component, total joint replacement for the metacarpophalangeal (MCP) joint of the hand and is made of PyroCarbon over Poco[®] graphite and has properties ideally suited for making implants to replace the small joints of the hand and foot.





Pyrolytic Graphite (PG) Washers



Up to 1m in diameter

Many people are familiar with pyrolytic graphite monochrometers as well as STM AFM standards, but PG washers are also used in furnaces as directional insulators and in solid rocket motors.



A2705V2004.

Pyrolytic Graphite (PG) Washers

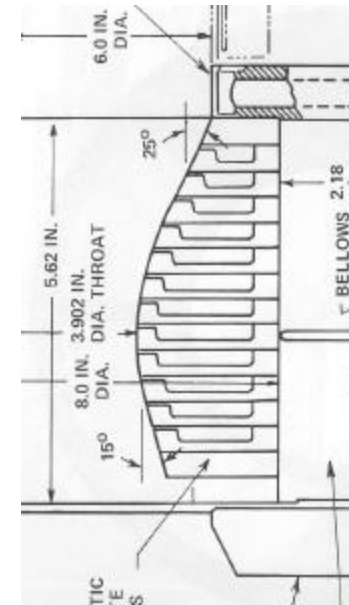
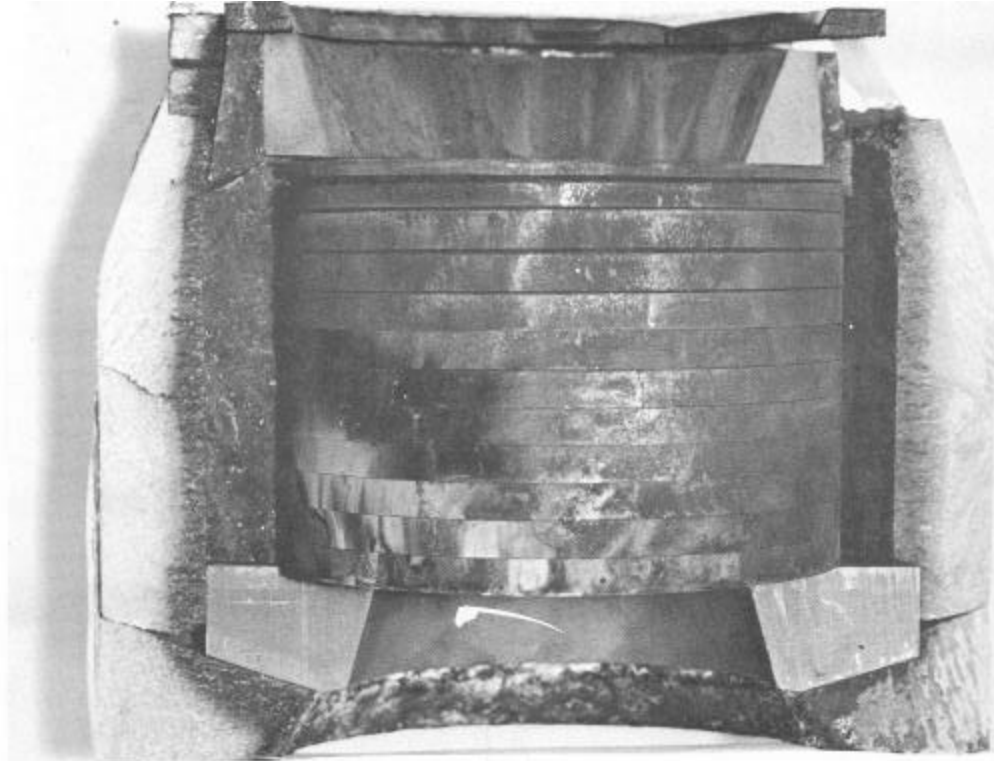

In solid rocket motors the PG washers are stacked so that their internal diameters form the nozzle throat.



American Carbon Society

SINTERED MESOPHASE



Approved for public release; distribution unlimited



Sintered Mesophase



Mesophase-carbon is an anisotropic nematic discotic liquid crystalline polyaromatic material that can be produced from a variety of precursors, such as, coal tar or mineral oil pitches.

It forms as a second phase from isotropic pitch through polymerization and condensation reactions at $\sim 350^{\circ}\text{C}$.

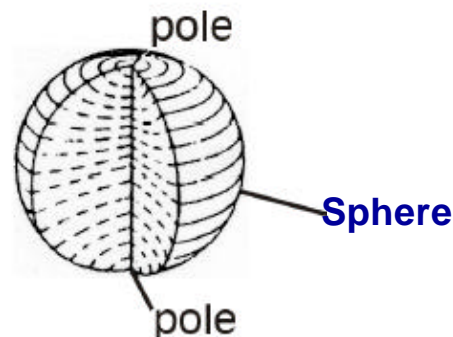

After forming the mesophase spherules from the isotropic phase, this process mills the resulting mixture and removes the isotropic phase by solvation leaving only mesophase powder, which is partially stabilized.

This powder is formed by compaction into a near-net-shaped part, the green body is machined slightly, and then sintered. After sintered it is machined again to bring part to final dimensions after extensive shrinkage.



A2705V2004.

Sintered Mesophase Production

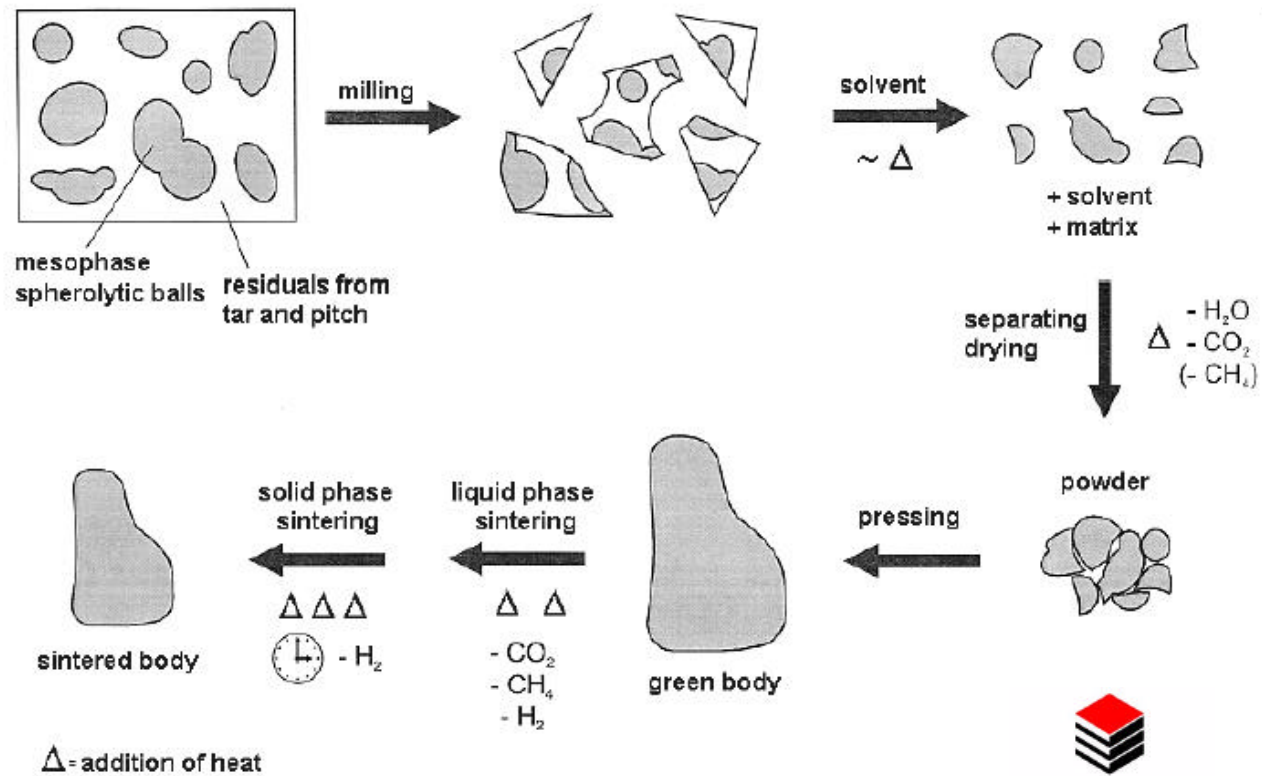



Sintered Mesophase Properties

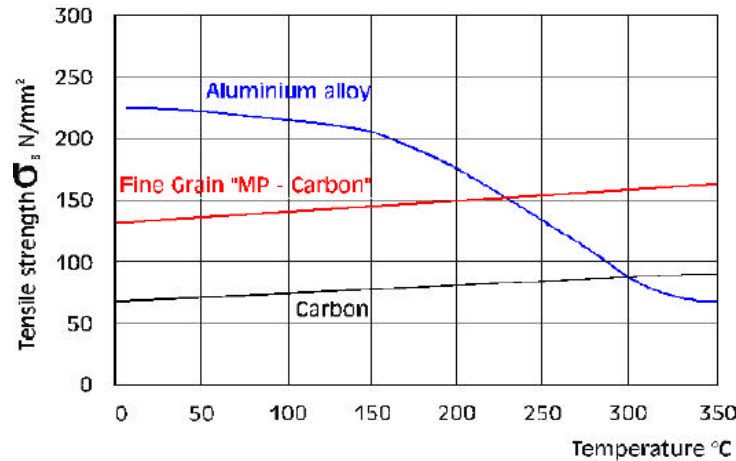

- Low thermal expansion
- Low density
- Good thermal shock behavior
- Increase of strength with increasing temperature

These properties along with the fact that the piston is self-lubricating due to the open pores acting as reservoirs made this an excellent piston material.

Properties	Unit	Aluminium Fine Grain Mesophase		
		Alloy	Graphite	Carbon
Density	g/cm³	2,7	1,86	1,89
Flexural Strength (RT)	MPa	220	50	127
Flexural Strength (570K)	MPa	80	90	180
Young's Modulus	GPa	80	12	12,2
Thermal Conductivity	W/mK	155	70	44
Thermal Expansion	x10⁻⁶K⁻¹	20	3,3	5,7



Sintered Mesophase Piston



Sintec Keramik GmbH & Co. KG

The use of self-lubricating mesophase pistons in two-stroke engines improves fuel efficiency and increases power while decreasing lubricant consumption and combustion emissions (CO, NO_x, and HC).



American Carbon Society

DIAMOND FILMS



Approved for public release; distribution unlimited



Diamond Coatings

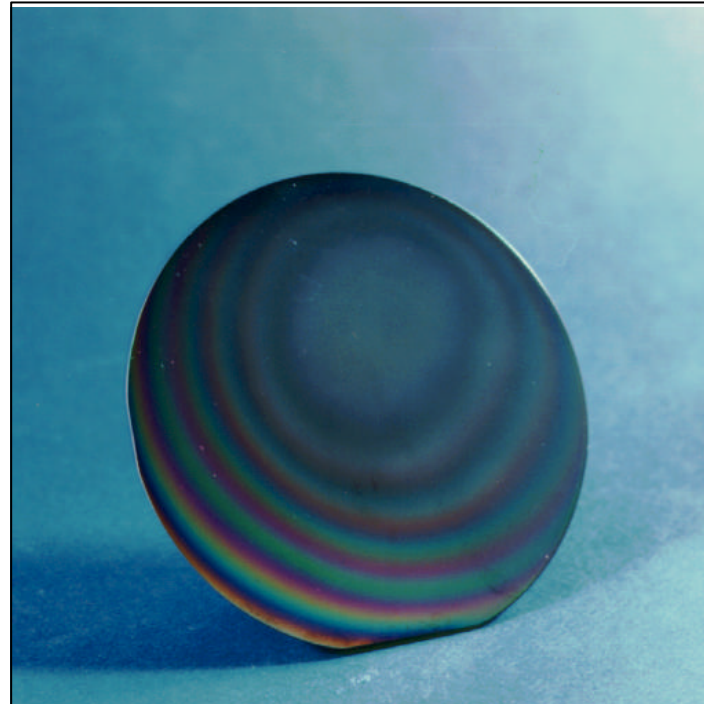

Diamond film coatings are hard and scratch-resistant. Used for contact surfaces such as bearings, wire drawing dies, as well as for tool coatings for cutting, grinding, drilling, etc.



CVD Diamond

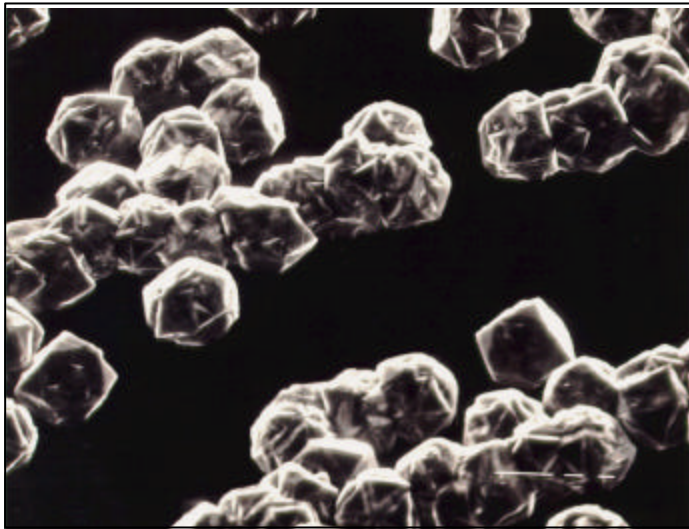

Discrete Crystals

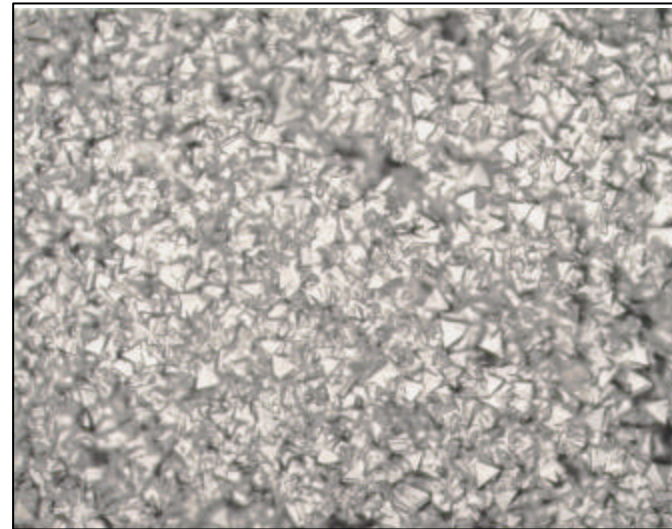

Diamond Film

A surface can be coated with diamonds using a diamond paste or by employing the Chemical Vapor Deposition (CVD) of diamond and diamond-like carbon using microwave plasma and hot-filament techniques.



American Carbon Society

FIBER REINFORCED COMPOSITES



Approved for public release; distribution unlimited



CARBON FIBERS



Polymer Precursor:

Formed by carbonization of a polymer fiber such as rayon or PAN (polyacrylonitrile). These fibers, which are relatively low cost, are not graphitizable so they have high strength but low moduli.

Pitch Precursor:

These fibers are formed from mesophase, petroleum or coal tar pitch. Through heat treatment to temperatures $> 2000^{\circ}\text{C}$ these fibers are graphitized giving them very high moduli (up to 900 GPa) and high thermal conductivity (three times that of copper).

Catalytic fibers:

Formed by the pyrolysis of hydrocarbons on a catalyst particle. The high purity fiber, which grows out of the particle, has similar properties to the pitch fiber, but offers a lower processing cost.



Comparison With Other Fibers



Fiber	Strength (MPa)	Modulus (GPa)	Diameter (u)	Density (g/cc)
S- Glass	4585	86	<u>10</u>	2.48
Kevlar 149	3450	228	12	1.47
PAN, T-300	3660	231	7	1.76
Pitch, P-25	1400	160	11	1.9
Pitch, P-120	2410	828	10	2.18



Carbon Fiber Reinforced Composites



Consist of carbon fibers surrounded by a matrix material, which can be a polymer (usually epoxy or phenolic), carbon, cement, or a metal.

For structural applications, the fibers are incorporated to add strength and stiffness.

For example, C-C composites are stronger than steel, stiffer than steel, and lighter than aluminum. Properties maintained (and actually increased) to > 3000o C.

Carbon fiber reinforcement can be chopped and random or can be continuous.

In a continuous fiber composite, the carbon fibers are usually oriented to carry the load while the matrix binds the fibers together transmitting the load among the fibers. The matrix also decreases the density.



Carbon Composite Preform Fabrication

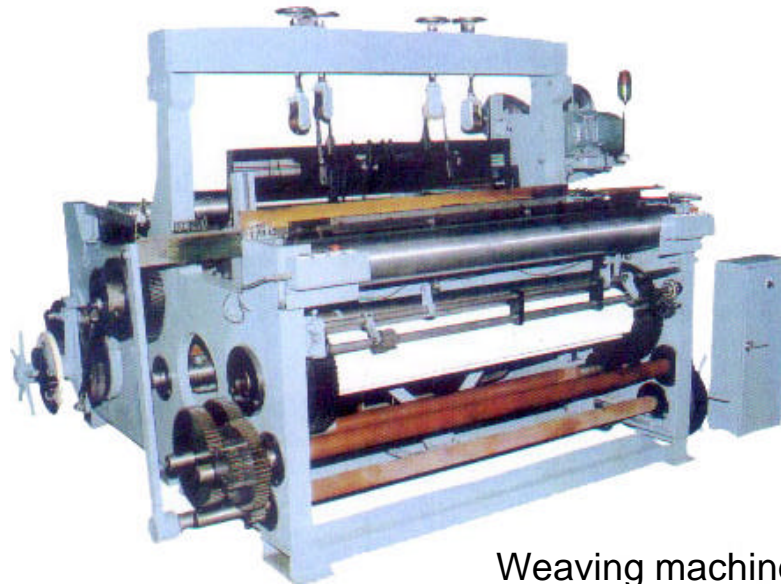

In composite fabrication, the first step is to form a carbon fiber preform with the fibers oriented for the desired mechanical properties. The preform can be formed as a felt or as a 2-D cloth lay-up. Alternatively the fibers can be braided, woven, filament wound

Weaving machine

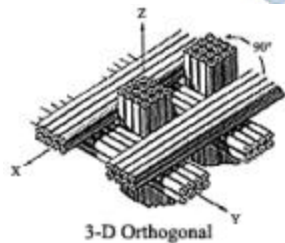

3-D Orthogonal

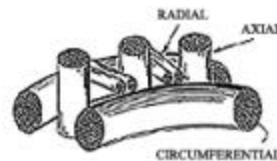

3-D Cylindrical



4-D In-Plane



4-D Pyramidal



Carbon Composite Preform Fabrication

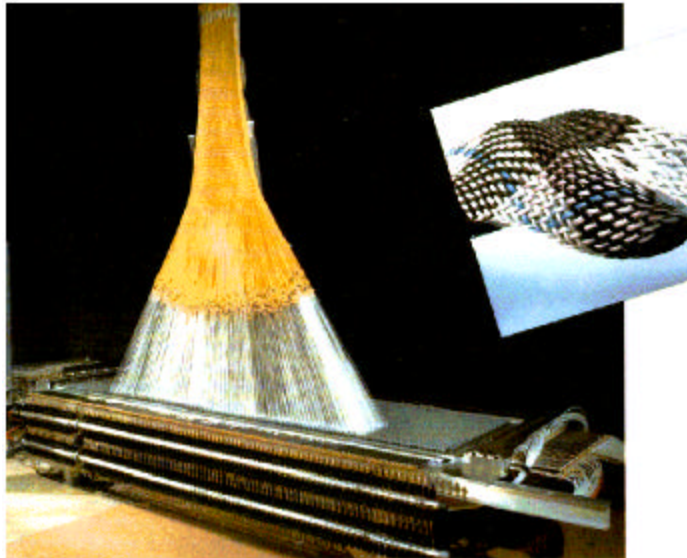

BRAIDING MACHINE

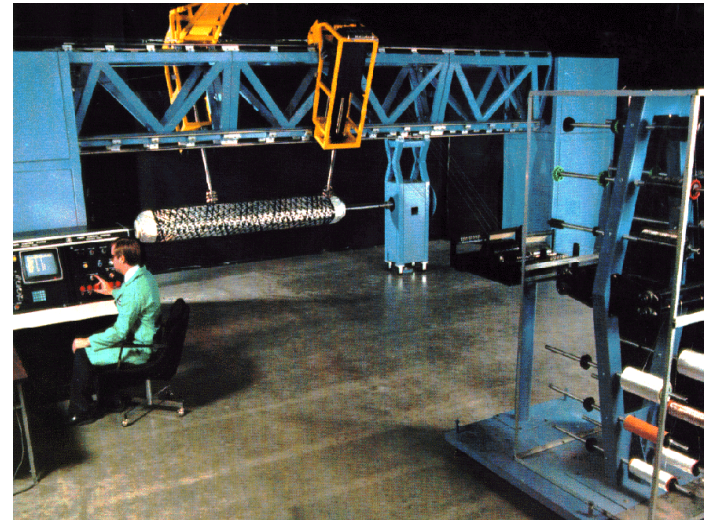

FILAMENT WINDING

In composite fabrication, the first step is to form a carbon fiber preform with the fibers oriented for the desired mechanical properties. The preform can be formed as a felt or as a 2-D cloth lay-up. Alternatively the fibers can be braided, woven, filament wound.



Carbon Composite Fabrication



After the preform is formed, the matrix or matrix precursor is used to fill the space between the fibers.

If a polymer matrix composite is desired, the polymer is used to fill the void space in the preform and then cured.

In a carbon-carbon composite, the carbon matrix is formed by a process called densification in which the matrix precursor is impregnated or infiltrated into the preform and then is converted to a char by a process called carbonization.

Depending on the application the carbon matrix is formed by pyrolysis of a polymer, hydrocarbon gas, or a pitch-based material.

During densification the composite may also experience machining and graphitization.



Preform Impregnation/Infiltration Methods



Polymer Precursor:

A polymer is placed between the carbon fibers to produce a carbon fiber reinforced polymer (CFRP). If this matrix is carbonized a carbon-carbon composite results. (Not graphitizable)

Pitch Precursor:

A hydrocarbon pitch material, such as, petroleum pitch, coal-tar pitch, mesophase pitch, or refined pitch is forced into the fiber preform under pressure after raising the temperature to decrease viscosity. Alternatively, mesophase can be polymerized *In Situ*. The pitch is then carbonized to produce a carbon-carbon (C-C) composite. (Graphitizable)

Chemical Vapor Infiltration:

The fiber preform is surrounded in a furnace by a hydrocarbon gas, such as methane or propylene. At elevated temperature the gas precursor cracks to elemental carbon on the fiber surfaces ultimately filling the preform and resulting in a carbon-carbon (C-C) composite. (Graphitizable)



Carbon Fiber Reinforced Sports Equipment



Graphite fibers decrease weight and add stiffness and speed to fishing rods, tennis racquets, hockey sticks, golf club and arrow shafts among others.





Carbon Fiber Reinforced Toys



Graphite fibers decrease weight and add stiffness and speed to bicycles, motorcycles, and race cars





Carbon Fiber Reinforced Pressure Vessels



Medical



9700 psi TVC tank for Delta Rocket



Escape slide & Life raft



SCUBA

Carbon and graphite fibers decrease weight of pressure vessel up to 70% over that of steel cylinders. High-performance hoop-wrapped and full-wrapped composite gas cylinders are used in numerous domestic and space applications. No degradation in properties with time



Paintball-4500 psi



CNG and Hydrogen Storage



Carbon Fiber Reinforcement Aeronautics

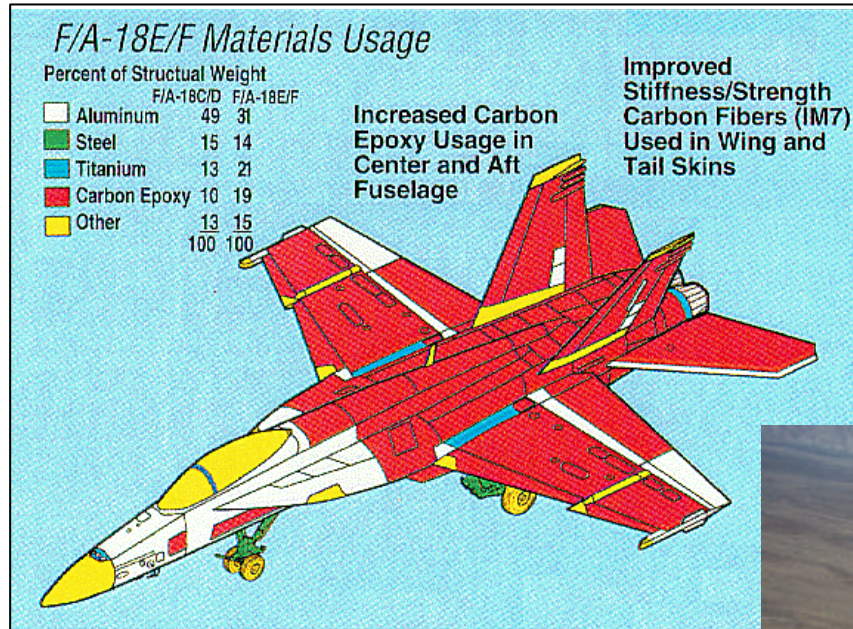

- Carbon-epoxy and carbon-phenolic are used in military aircraft.





Carbon Fiber Reinforcement in Aeronautics



Gossamer Albatross

Carbon-epoxy and carbon phenolic were first used in high performance aircraft



Gossamer Penguin



Voyager



Carbon Fiber Reinforcement in Aeronautics



Carbon-epoxy and carbon phenolic are used in commercial aircraft.



Adam Aircraft



Carbon Fiber Reinforcement in Astronautics



AFRL/VS developed the technology for and produced the first isogrid stiffened payload fairing (shroud) by filament winding carbon fiber.



Carbon Fiber Reinforcement in Construction-Bridge Retrofits



Carbon fabric with epoxy matrix has been used to rehabilitate highway bridge decks, caps, and girders. The retrofit results in a structure that is at least 25% stronger and substantially increases the bridge life. It is accomplished at a fraction (~25%) of the cost of a conventional repair and requires no lane closures.





Carbon Fiber Reinforcement in Construction-Curtain Wall



A curtain wall system is a lightweight exterior cladding which is hung on the building structure, usually from floor to floor. High performance curtain walls now incorporate cement with chopped carbon fiber



Carbon- Carbon Composites in Transportation



Carbon-carbon aircraft brakes are used in all military aircraft and a vast majority of the commercial fleet. This is by far the largest application of carbon-carbon composites.

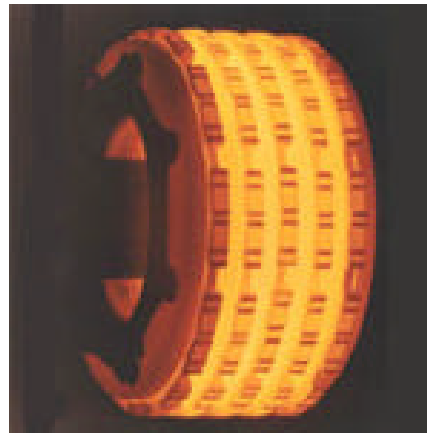

Approved for public release; distribution unlimited



Carbon- Carbon Composites in Transportation



Carbon-carbon is also used for brakes and clutches in race cars and motorcycles as well as for high temperature hardware





Carbon-Carbon Composites in Astronautics

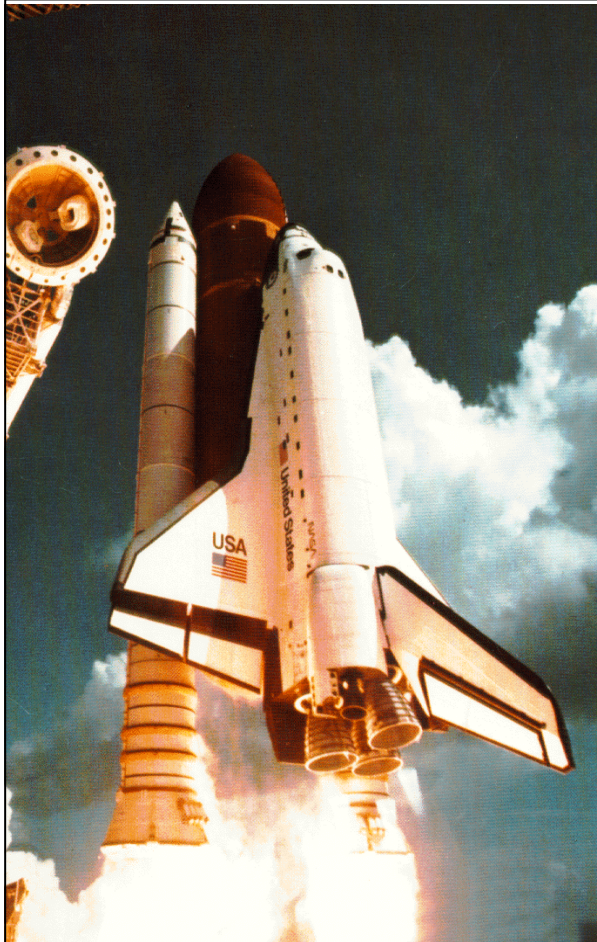

Carbon-carbon in nose-tips, leading edges, nozzles and exit cones.





Carbon-Carbon Composites in Astronautics

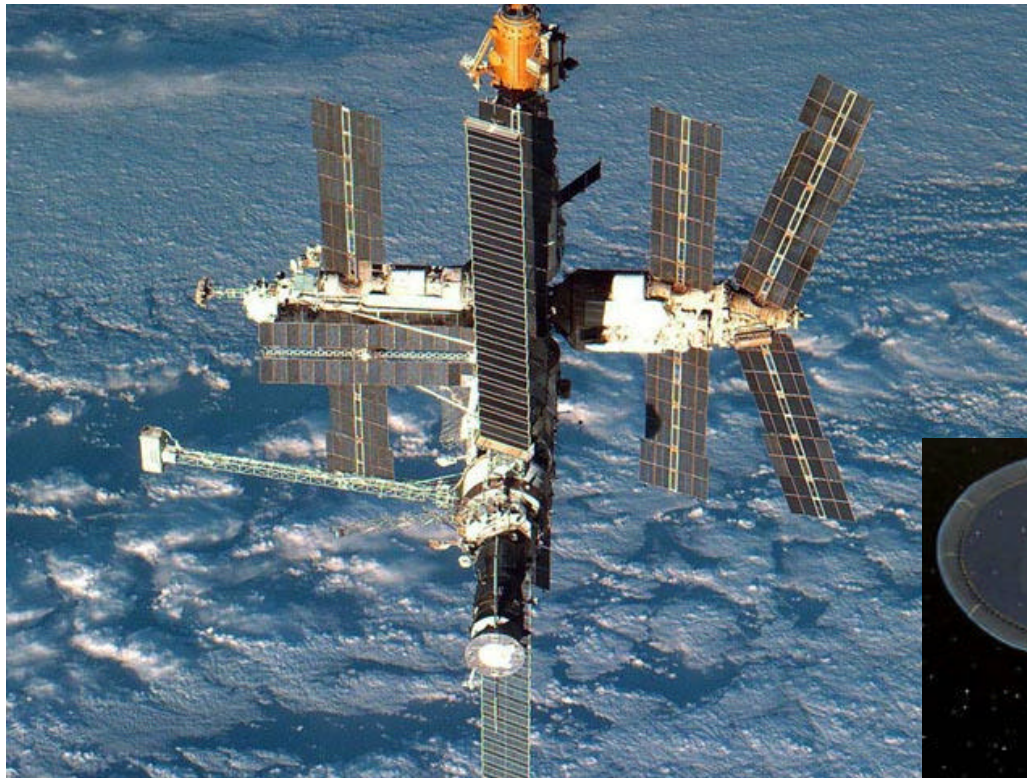

TABLE 1

	Graphite Composite (aerospace grade)	Graphite Composite (commercial grade)	Fiberglass Composite	Aluminum 6061 T-6	Steel, Mild
Cost \$/LB	\$20-\$250+	\$5-\$20	\$1.50-\$3.00	\$3	\$.30
Strength (psi)	90,000-200,000	50,000-90,000	20,000-35,000	35,000	60,000
Stiffness (psi)	10 x 10 ⁶ - 50 x 10 ⁶	8 x 10 ⁶ - 10 x 10 ⁶	1 x 10 ⁶ - 1.5 x 10 ⁶	10 x 10 ⁶	30 x 10 ⁶
Density (lb/in³)	.050	.050	.055	.10	.30
Specific Strength	1.8 x 10 ⁶ - 4 x 10 ⁶	1 x 10 ⁶ - 1.8 x 10 ⁶	363,640 - 636,360	350,000	200,000
Specific Stiffness	200 x 10 ⁶ - 1,000 x 10 ⁶	160 x 10 ⁶ - 200 x 10 ⁶	18 x 10 ⁶ - 27 x 10 ⁶	100 x 10 ⁶	100 x 10 ⁶
CTE (in/in-F)	-1 x 10 ⁻⁶ - 1 x 10 ⁻⁶	1 x 10 ⁻⁶ - 2 x 10 ⁻⁶	6 x 10 ⁻⁶ - 8 x 10 ⁻⁶	13 x 10 ⁻⁶	7 x 10 ⁻⁶



Carbon-Carbon Composites in Astronautics



Carbon-Carbon is used in space applications, such as platforms, booms, mirror and support structures because it is strong, stiff, light, and has low thermal expansion

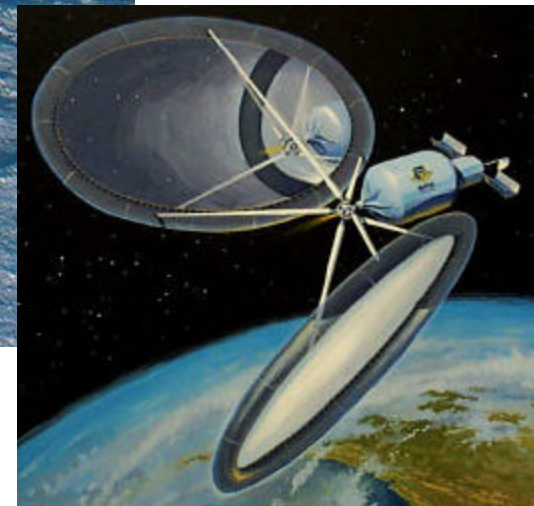



Carbon-Carbon Composites in Astronautics

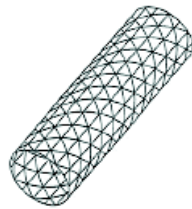

Isogrid structures are light, strong, and rigid. They can be made inexpensively using filament winding techniques.



Cylinder



Cone



Panel

Carbon-Carbon is used in space applications, such as platforms, booms, mirror and support structures because it is strong, stiff, light, and has low thermal expansion



Rigidization on command inflatable structures with UV cure in Sunlight



KYK Oxynon® Sintering Furnace

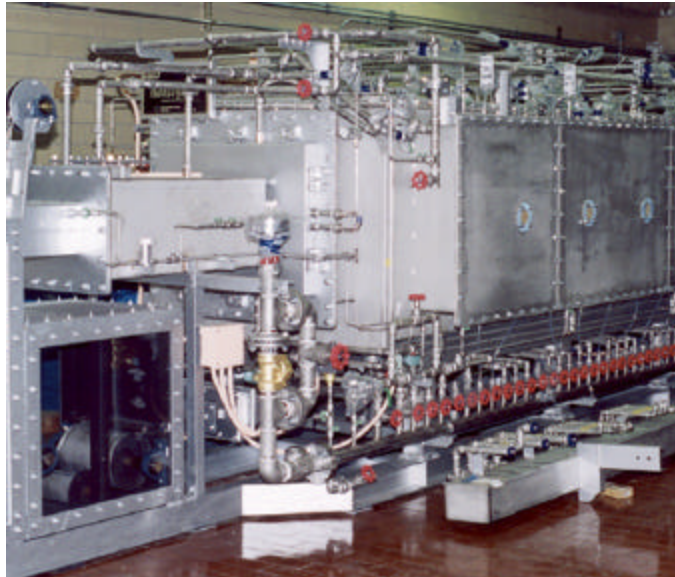

- Can sinter & braze up to 2000°C.
- Continuous graphite channel is 25cm wide & 12.5cm high.
- Belt speed up to 25 cm/min.
- Eliminating refractory metal oxide lining allows low oxygen partial pressure operation.

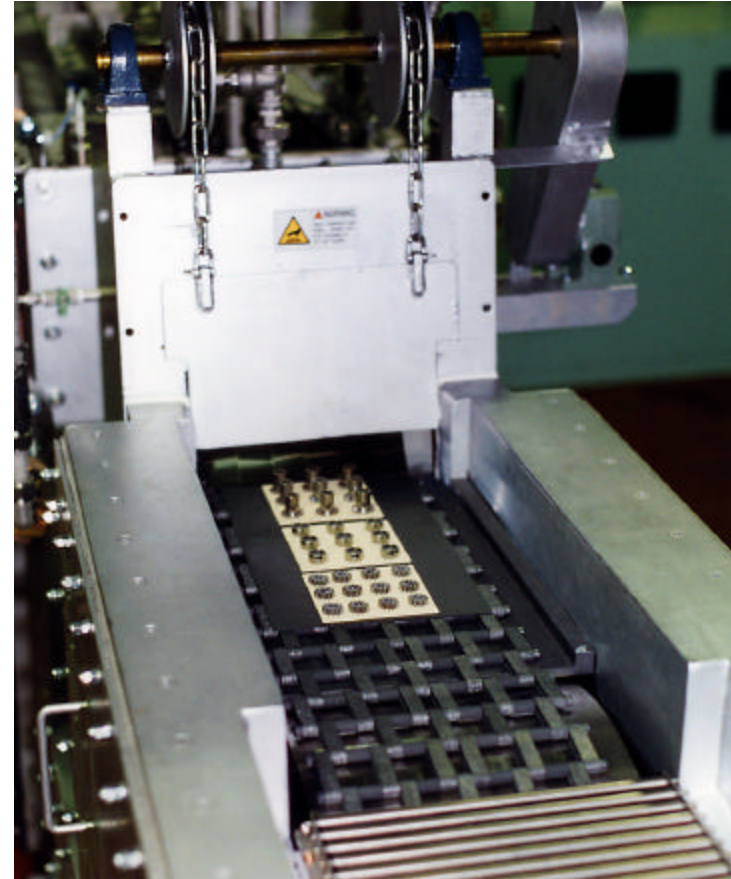



KYK Oxynon® Sintering Furnace

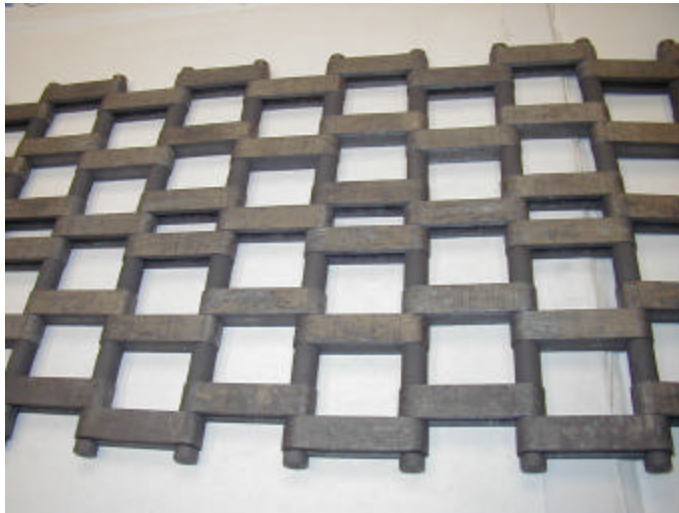

Low Thermal Mass
High Strength
Thermal Shock Resistant
Energy Efficient
Fast Heating and Cooling
Max Temperature- 2600°C
Max load- 12 kPa (250 lb/ft²)

Belt consists of light weight, high strength carbon composite links and threaded rods.

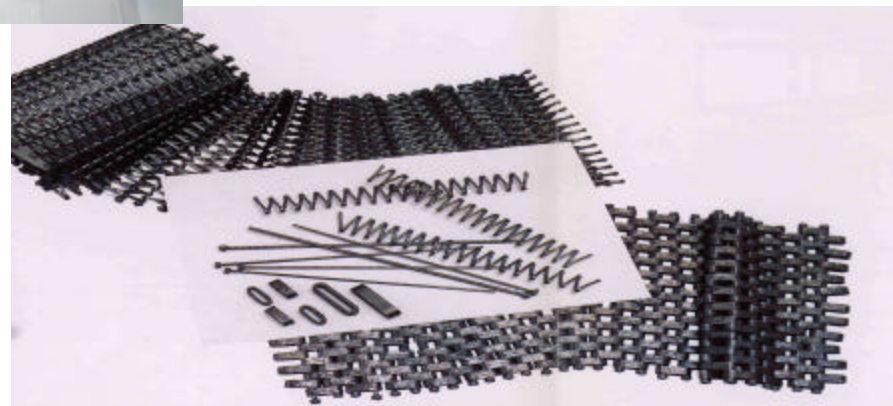



2004 CORVETTE



**The Model Z06 has a carbon fiber reinforced hood (bonnet).
It has a 1.2 mm thick skin. First high gloss paint application.**



Conclusion



Carbon is a very diverse, useful and important material. Modern society as we know it could not function without numerous structural carbon products.