

AFRL-ML-WP-TR-2004-4196

**ENDURANCE PUMP TEST WITH MIL-PRF-83282 HYDRAULIC FLUID,
PURIFIED WITH MALABAR
PURIFIER**



**Shashi K. Sharma, Carl E. Snyder, Jr., and
Lois J. Gschwender**

**Nonstructural Materials Branch (AFRL/MLBT)
Nonmetallic Materials Division
Materials and Manufacturing Directorate
Air Force Research Laboratory, Air Force Materiel Command
Wright-Patterson AFB, OH 45433-7750**

George W. Fultz and Timothy A. Jenney

**University of Dayton Research Institute
300 College Park Avenue
Dayton, OH 45469-0001**

JUNE 2004

Interim Report for 01 January 2002 – 01 June 2004

Approved for public release; distribution is unlimited.

STINFO INTERIM REPORT

**MATERIALS AND MANUFACTURING DIRECTORATE
AIR FORCE RESEARCH LABORATORY
AIR FORCE MATERIEL COMMAND
WRIGHT-PATTERSON AIR FORCE BASE, OH 45433-7750**

NOTICE

Using government drawings, specifications, or other data included in this document for any purpose other than government procurement does not in any way obligate the US Government. The fact that the government formulated or supplied the drawings, specifications, or other data does not license the holder or any other person or corporation or convey any rights or permission to manufacture, use, or sell any patented invention that may relate to them.

This report is releasable to the National Technical Information Service (NTIS). At NTIS, it will be available to the general public, including foreign nations.

This technical report has been reviewed and is approved for publication.

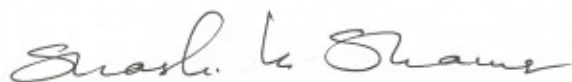

SHASHI K. SHARMA, Program Manager
Nonstructural Materials Branch
Nonmetallic Materials Division

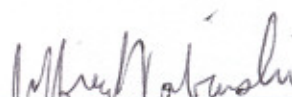

JEFFREY S. ZABINSKI, Chief
Nonstructural Materials Branch
Nonmetallic Materials Division



ROBERT M. SUSNIK, Deputy Chief
Nonmetallic Materials Division
Materials and Manufacturing Directorate

Do not return copies of this report unless contractual obligations or notice on a specific document requires its return.

REPORT DOCUMENTATION PAGE

Form Approved
OMB No. 0704-0188

The public reporting burden for this collection of information is estimated to average 1 hour per response, including the time for reviewing instructions, searching existing data sources, searching existing data sources, gathering and maintaining the data needed, and completing and reviewing the collection of information. Send comments regarding this burden estimate or any other aspect of this collection of information, including suggestions for reducing this burden, to Department of Defense, Washington Headquarters Services, Directorate for Information Operations and Reports (0704-0188), 1215 Jefferson Davis Highway, Suite 1204, Arlington, VA 22202-4302. Respondents should be aware that notwithstanding any other provision of law, no person shall be subject to any penalty for failing to comply with a collection of information if it does not display a currently valid OMB control number. **PLEASE DO NOT RETURN YOUR FORM TO THE ABOVE ADDRESS.**

1. REPORT DATE (DD-MM-YY) June 2004		2. REPORT TYPE Interim		3. DATES COVERED (From - To) 01/01/2002 – 06/01/2004	
4. TITLE AND SUBTITLE ENDURANCE PUMP TEST WITH MIL-PRF-83282 HYDRAULIC FLUID, PURIFIED WITH MALABAR PURIFIER				5a. CONTRACT NUMBER F33615-00-D-5021	
				5b. GRANT NUMBER	
				5c. PROGRAM ELEMENT NUMBER 62102F	
6. AUTHOR(S) Shashi K. Sharma, Carl E. Snyder, Jr., and Lois J. Gschwender (AFRL/MLBT) George W. Fultz and Timothy A. Jenney (University of Dayton Research Institute)				5d. PROJECT NUMBER 4347	
				5e. TASK NUMBER 60	
				5f. WORK UNIT NUMBER FK	
7. PERFORMING ORGANIZATION NAME(S) AND ADDRESS(ES) Nonstructural Materials Branch (AFRL/MLBT) Nonmetallic Materials Division Materials and Manufacturing Directorate Air Force Research Laboratory, Air Force Materiel Command Wright-Patterson AFB, OH 45433-7750				8. PERFORMING ORGANIZATION REPORT NUMBER University of Dayton Research Institute 300 College Park Avenue Dayton, OH 45469-0001	
9. SPONSORING/MONITORING AGENCY NAME(S) AND ADDRESS(ES) Materials and Manufacturing Directorate Air Force Research Laboratory Air Force Materiel Command Wright-Patterson AFB, OH 45433-7750				10. SPONSORING/MONITORING AGENCY ACRONYM(S) AFRL/MLBT	
				11. SPONSORING/MONITORING AGENCY REPORT NUMBER(S) AFRL-ML-WP-TR-2004-4196	
12. DISTRIBUTION/AVAILABILITY STATEMENT Approved for public release; distribution is unlimited.					
13. SUPPLEMENTARY NOTES This material is declared a work of the U.S. Government and is not subject to copyright protection in the United States.					
14. ABSTRACT The possible deterioration of the fluid during use or the potential for the purifier to remove some of the performance improving additives from the fluid as well as the contaminants was investigated. Endurance aircraft hydraulic pump tests under carefully controlled conditions were previously conducted using hydraulic fluid purified with a rotating-disk and vacuum type purifier, the portable purifier manufactured by Pall Corporation, to assess the potential negative effect the fluid purifier could have on hydraulic fluid performance. In this study, similar tests were conducted with a mist and vacuum type purifier, manufactured by Malabar International. Fluid samples were taken at selected intervals during the pump tests and key physical and chemical properties were determined. Pump tests with both fresh and purified MIL-PRF_83282 hydraulic fluids were successfully completed, and there was no apparent difference in pump performance or in fluid characteristics with either fluid. The mist and vacuum type Malabar purifier is therefore similarly benign to the hydraulic fluid as are the Pall portable purifiers. These Malabar mist and vacuum type purifiers will be integrated into some new hydraulic test stands being procured by the U.S. Air Force.					
15. SUBJECT TERMS Hydraulic fluid, purifier, pump tests					
16. SECURITY CLASSIFICATION OF:			17. LIMITATION OF ABSTRACT: SAR	18. NUMBER OF PAGES 60	19a. NAME OF RESPONSIBLE PERSON (Monitor) Shashi K. Sharma 19b. TELEPHONE NUMBER (Include Area Code) (937) 255-9029
a. REPORT Unclassified	b. ABSTRACT Unclassified	c. THIS PAGE Unclassified			

TABLE OF CONTENTS

Section	Page
1.0 INTRODUCTION	1
2.0 TEST OBJECTIVE	2
3.0 APPROACH	2
3.1 Pump Test Plan	3
3.2 Hydraulic Pump Test Stand	5
3.3 Malabar Portable Fluid Purifier	6
3.4 Pump Tests	8
3.4.1 Pump Test With Fresh MIL-PRF-83282 (Test 40)	8
3.4.2 Pump Test With Purified MIL-PRF-83282 (Test 41)	8
4.0 TEST RESULTS	9
5.0 CONCLUSION	12
6.0 REFERENCES	12
7.0 ACKNOWLEDGMENTS	12
8.0 APPENDICES	
Appendix A: Inspection Reports, Test 40	13
Appendix B: Inspection Reports, Test 41	16
Appendix C: Purfier/Pump Stand Interface for Test 41	19
Appendix D, Photographs of Pump Parts	20

8.1 LIST OF FIGURES

Figure	Page
1. Malabar Hydraulic Service Stand (mule)	1
2. Malabar Purifier Mounted on a Portable Cart	2
3. Pump Test Stand Schematic	5
4. Pump Test Stand	5
5. Malabar Purifier Interface with the Pump Test Stand	6
6. Malabar Purifier Schematic	7
7. Case Drain Flow and Viscosity for Test 40 with fresh MIL-PRF-83282	10
8. Case Drain Flow and Viscosity for Test 41 with purified MIL-PRF-83282	10

8.2 LIST OF TABLES

Table	Page
1. Fluid Analyses, Pump Test #40 with Fresh MIL-PRF-83282	11
2. Fluid Analyses, Pump Test #41 with Purified MIL-PRF-83282	11
3. Ball Joint Play and Shoe Flange Thickness – Test 40	15
4. Ball Joint Play and Shoe Flange Thickness – Test 41	18

Title: Endurance Pump Tests with MIL-PRF-83282 Hydraulic Fluid, Purified with Malabar Purifier

Lead Author: Shashi K. Sharma, Carl E. Snyder, Jr. and Lois J. Gschwender
Air Force Research Laboratory

George W. Fultz and Timothy A. Jenney,
University of Dayton Research Institute

Abstract:

Used hydraulic fluid is one of the largest contributors to the waste stream generated at most US military installations. The armed services have investigated possible avenues to reduce or eliminate this waste stream by fluid purification and reuse. The possible deterioration of the fluid during use or the potential for the purifier to remove some of the performance improving additives from the fluid as well as the contaminants was investigated. Endurance aircraft hydraulic pump tests under carefully controlled conditions were previously conducted using hydraulic fluid purified with a rotating-disk and vacuum type purifier, the portable purifier manufactured by Pall Corporation, to assess the potential negative effect the fluid purifier could have on hydraulic fluid performance. In this study, similar tests were conducted with a mist and vacuum type purifier, manufactured by Malabar International. Fluid samples were taken at selected intervals during the pump tests and key physical and chemical properties were determined. Pump tests with both fresh and purified MIL-PRF-83282 hydraulic fluids were successfully completed, and there was no apparent difference in pump performance or in fluid characteristics with either fluid. The mist and vacuum type Malabar purifier is therefore similarly benign to the hydraulic fluid as are the Pall portable purifiers. These Malabar mist and vacuum type purifiers will be integrated into some new hydraulic test stands being procured by the U.S. Air Force.

1.0 INTRODUCTION

Used hydraulic fluid is one of the largest contributors to the waste stream generated at most US Air Force bases. In most cases, the used hydraulic fluid collected is the by-product of an aircraft maintenance action in which some component is being replaced, repaired, etc. The fluid is not being changed because it is “worn out” or extremely contaminated. However, this used fluid is still collected in rather large quantities for disposal. It is estimated the Air Force alone uses approximately 1,000,000 gallons of hydraulic fluid per year, much of that in replacing hydraulic fluid lost during maintenance actions. The purification and reuse of hydraulic fluid can result in annual savings of up to \$15 million.

The viability of using hydraulic fluid purification as a means of reducing the waste stream has been previously investigated. Long-term pump tests were conducted with both with MIL-PRF-5606 [1], and MIL-PRF-83282 [2], to assess any negative impact on system performance due to purification by a portable purifier made by Pall Corporation.

The U.S. Air Force is procuring hydraulic service stands (mules) from Malabar International that includes a built-in purification circuit (Fig. 1). These test stands have a 60-gallon capacity fluid reservoir. After servicing the aircraft, the fluid in the reservoir can become contaminated. The built-in purifier then cleans the fluid in a kidney-loop fashion, replenishing the reservoir with purified fluid. In order to assess the impact of the Malabar purifier, Malabar International provided a portable version of the purification circuit (Fig. 2). Endurance pump tests with both fresh and purified MIL-PRF-83282 fluids were conducted to assess any negative impact on pump/system performance due to purification by the Malabar purifier.

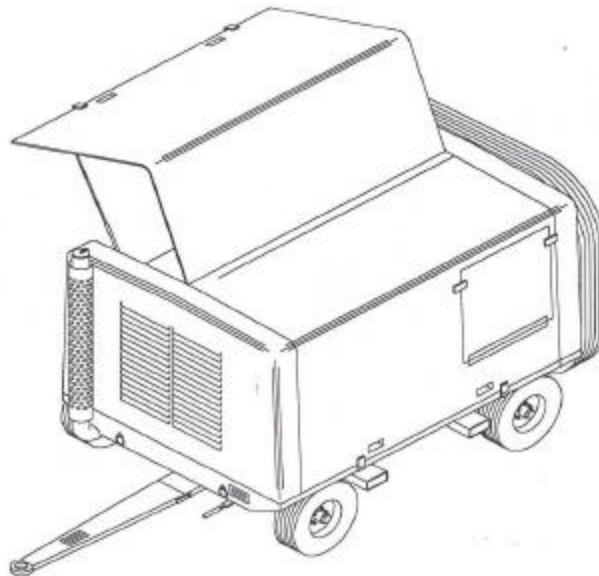

Fig.1 Malabar Hydraulic Service Stand (mule)



Fig. 2 Malabar Purifier Mounted to a Portable Cart

2.0 TEST OBJECTIVE

The objective of this program was to perform accelerated endurance pump testing using both fresh and purified MIL-PRF-83282 hydraulic fluid, to determine if this fluid purification process has any adverse effect on pump life or hydraulic fluid characteristics.

3.0 APPROACH

The approach proposed and approved was to run long-term experiments with both fresh and purified MIL-PRF-83282 hydraulic fluid in the AFRL/MLBT in-house pump test facility. Fluid samples were taken at selected intervals during both tests and key physical and chemical properties were determined. The pump operating characteristics were monitored, and the pump was disassembled for visual inspection periodically during both tests.

Two, 1500-hour tests were run on Vickers Model PV3-075-15, to determine if purifying the hydraulic fluid was acceptable from the standpoint of fluid properties and pump wear. The specimen pump is a constant pressure, variable displacement/ delivery type rated at 22.7 gpm, 3000 psig, and 7500 rpm. If the purifier removed any of the additives from the fluid or changed its performance characteristics, it could make the fluid unacceptable for reuse. Also, if the fluid properties were changed significantly, it could affect pump performance and/or wear.

A baseline test (Test 40) was conducted using fresh MIL-PRF-83282 hydraulic fluid (no purification). The second test (Test 41) was conducted with MIL-PRF-83282 hydraulic fluid, circulated for 40 minutes through the Malabar purifier at every 200-hour interval. Analysis of the pump test results was carried out to determine if the purification had any adverse effect on pump performance or fluid characteristics.

Before each test, the pump was disassembled to photograph its parts and document the condition of critical wear surfaces. This photography and inspection process was repeated after 500, 1000 and 1500 hours to check for any physical degradation or dimensional changes. For brevity, only the pre-test and final photographic sets are included in this report. The inspection reports for all the intervals are included.

3.1 PUMP TEST PLAN

TEST FLUIDS:

TEST 40: Fresh MIL-PRF-83282
TEST 41: Purified MIL- PRF-83282 from the same batch as Test 40

TEST PUMP:

Vickers Model PV3-075-15 Pump (new or rebuilt pump for each test)

PRE-TEST/POST TEST INSPECTION:

1. Partially disassemble the pump to inspect the valve plate, cylinder barrel, pistons, piston-shoes, yoke and other critical surfaces. Mark the piston index and the corresponding cylinder bore (with Techwipe) to confirm the pistons return to their corresponding original cylinder bores during reassembly.
2. Take the necessary photographs to document the general condition of the pump, with minimum disassembly. Note the visual appearance of all parts of interest and measure the dimensions of ball joint endplay and piston shoe thickness.

TEST CONDITIONS:

Pump Shaft Speed: 5000 rpm
Pump Inlet Pressure: 70 psig
Pump Outlet Pressure: 3000 psig
Max Fluid Temperature: 255 °F
Pump Outlet Flow: Cycle between 12.5 gpm and 3 gpm every minute

TEST DURATION: 1500 total hours or performance degradation, whichever occurs first.

PERFORMANCE PARAMETERS :

Flow Rates:	pump case drain and pump outlet
Pressures:	pump outlet, and pump case drain
Fluid Temperatures:	pump inlet, pump outlet, and pump case drain
Heat Rejection Rate:	coolant flow rates and heat exchanger temperature differential
Torque:	electric drive motor torque

TEST 40:

1. Fill the test stand with fresh MIL-PRF-83282 and bleed any entrained air out of the stand.
2. Start the pump under low load (~ 3 gpm main flow) and increase speed to 5000 rpm)
3. Stabilize the fluid temperature so the maximum temperature in the circuit is 250-255°F (usually in the case drain).
4. Take 50 ml fluid sample at 0 test hours (immediately following bleeding the stand), again at 50 and 100 hours and at every 100 hours thereafter.

TEST 41:

1. Fill the test stand and purifier with fresh MIL-PRF-83282 and bleed any entrained air out of the stand.
2. Configure the stand fluid flow loop to run through the purifier and operate the purifier for 40 minutes. Take a 150 ml sample of the purified fluid.
3. Return the stand configuration to the original fluid flow loops and bleed.
4. Start the pump under low load (~3 gpm main flow) and increase speed to 5000 rpm
5. Stabilize the fluid temperature so the maximum temperature in the circuit is 250-255 °F (usually in the case drain).
6. Take a 50 ml sample after 100 hours of running.
7. Take a 150 ml sample at 200 hours and stop the test.
8. Repeat steps 2 through 5.
9. Take a 150 ml sample at 400 hours and stop the test.
10. Repeat steps 2 through 5.
11. At 500 hours, take a 150 ml fluid sample and stop the test. Disassemble the pump for inspection and photography.
12. Reassemble the pump, and mount it to the stand, then bleed the stand. Take a 150 ml sample.
13. Repeat steps 4 and 5.
14. Repeat steps 2 through 5 at 600 and 800 hours.
15. At 1000 hours, repeat steps 11 through 13.
16. Repeat steps 2 through 5 at 1200 hours and 1400 hours.
17. Stop the tests after 1500 total hours or when degradation of performance is observed.
18. Save filter elements and fluid from the test

3.2 HYDRAULIC PUMP TEST STAND

The pump test stand was designed primarily for testing new and experimental hydraulic fluids using small to medium displacement aircraft hydraulic pumps. A schematic of the test stand is shown in Fig. 3. The pump test stand has been described in previous publications [1, 2]. Fig 4 shows the test stand and Fig 5 shows its interface with the Malabar purifier.

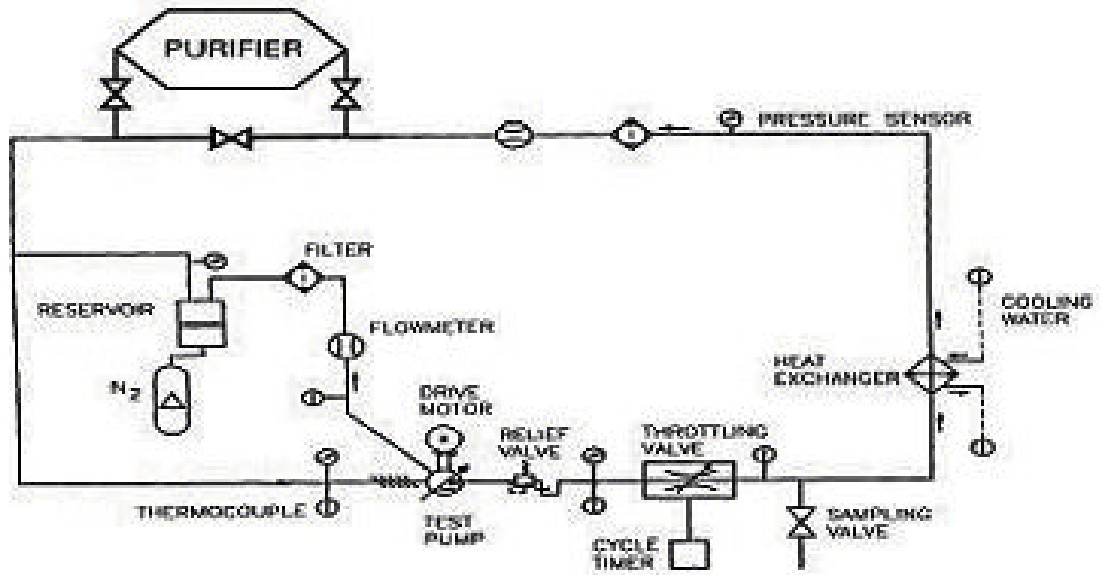

Fig. 3 Test Stand Schematic

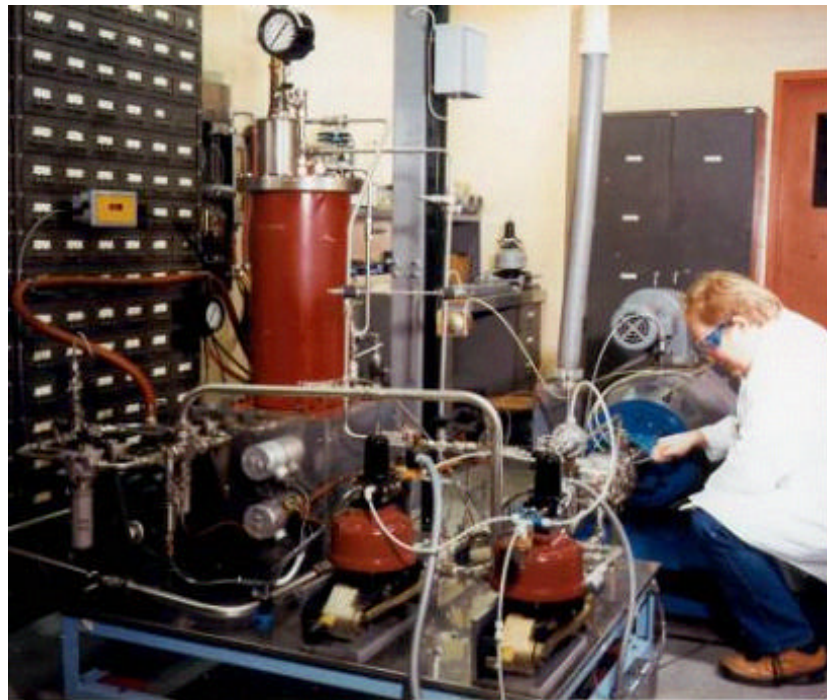

Fig. 4 Pump Test Stand

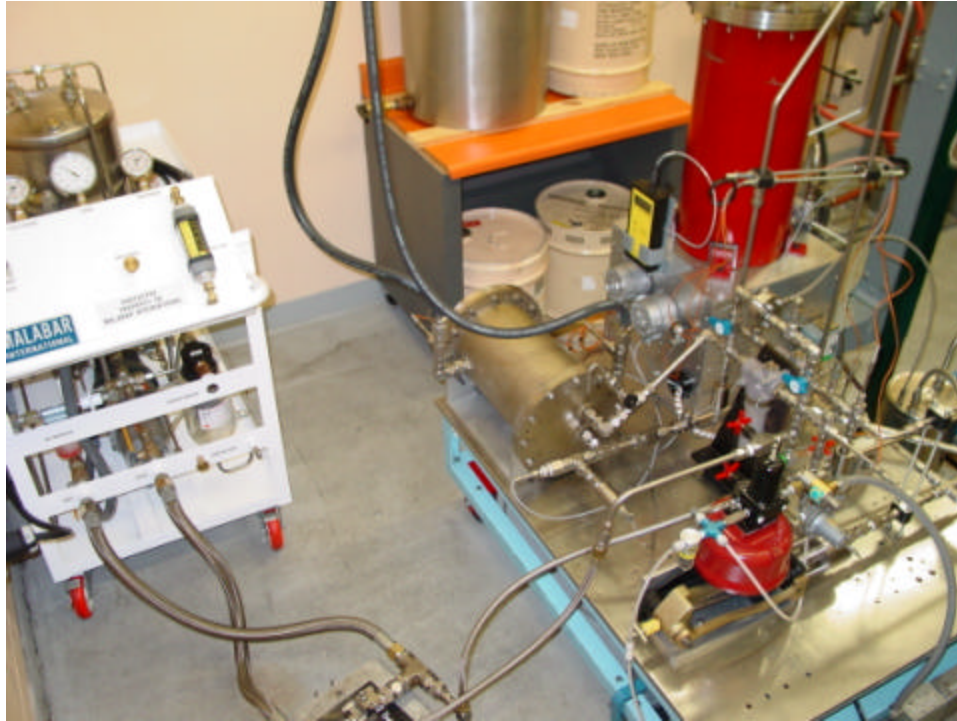

Fig. 5 Malabar Purifier Interface with the Pump Test Stand

3.3 MALABAR PORTABLE FLUID PURIFIER

The Malabar International purifier is designed to remove water, air, chlorinated solvents, and particulate from lubricating, hydraulic and heat transfer fluids. The purifier is incorporated into the Malabar Hydraulic Service Stand (see Fig 1) by connecting it to the main reservoir in kidney-loop fashion. A schematic of the purifier is shown in Fig. 6. For this investigation, the specimen purifier was mounted within a portable frame (see Fig. 2).

Malabar Purifier Specifications:

Inlet Fluid Temp:	+145 °F (max)/62 °C (max)
Fluid Circulation Rate:	3 gpm (max)
Operating Viscosity:	1300 SSU (max)
Discharge Pressure:	70 psig (max)
Vacuum Chamber Operating VAC:	24" Hg \pm 2" Hg
Inlet Pressure:	+20 psig (max)
Inlet Pressure:	-10" Hg (min)
Power Requirements:	120 Volts, 15 Amps, 60 Hz, 1 Phase 20 kW max. Connected load
Dimensions:	34" H x 27 1/2" W x 34" L (max)

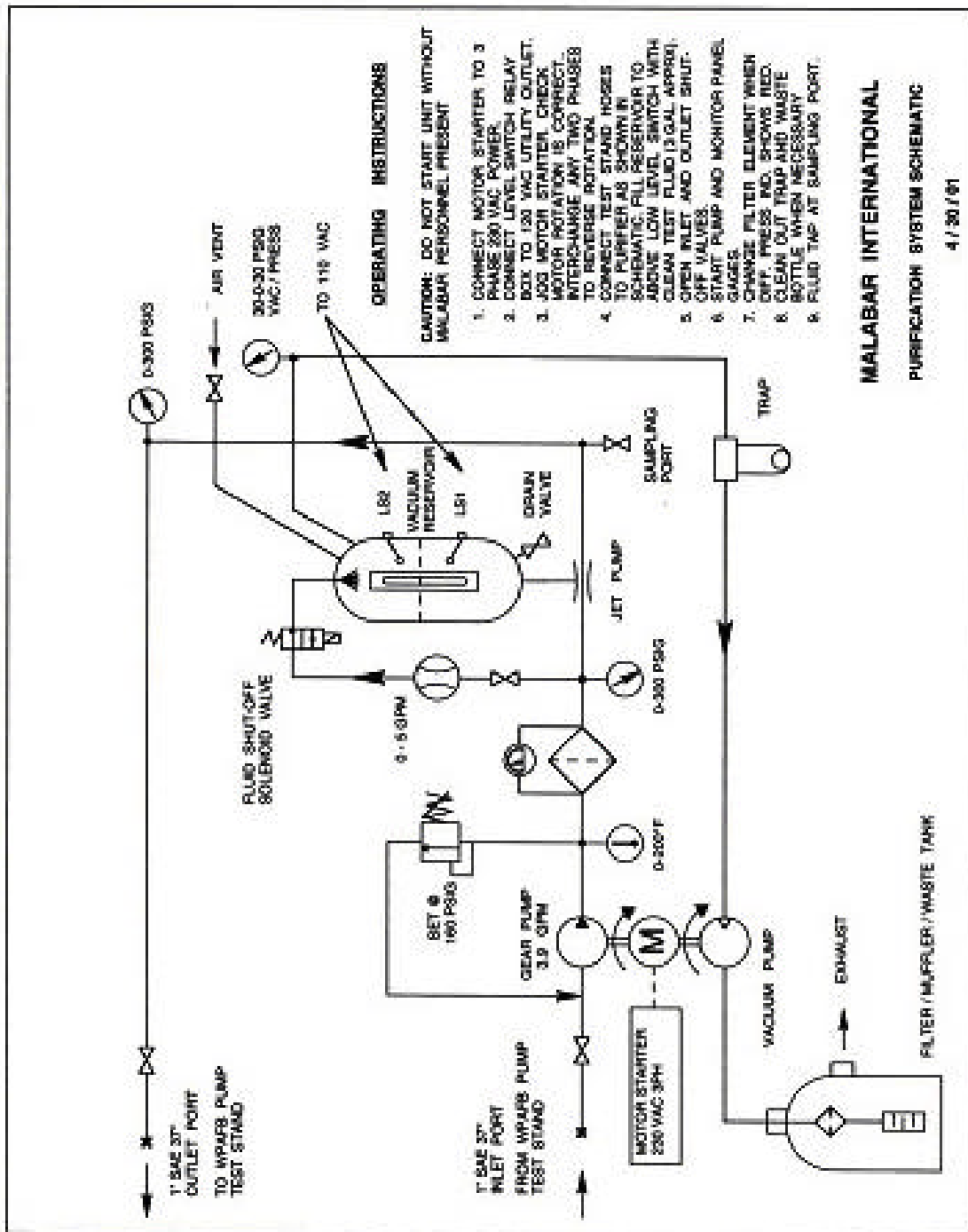

Fig. 6 Malabar Purifier Schematic

3.4 PUMP TESTS

Pump Test 40 and 41 were conducted according to the test plans in Section 3.1. The pump tests were carried out at the in-house test facility in the Materials and Manufacturing Directorate, Air Force Research Laboratory, Wright-Patterson Air Force Base. The test circuit (see Fig. 3) consisted of a drive motor, a throttling valve, heat exchanger, reservoir, 5-micron filters and other accessories. Various flow, pressure and temperature sensors were used to monitor the test parameters. A torque sensor was mounted between the drive motor and the test pump. The stand was equipped with computerized data acquisition and control system, with automatic safety interlocks. Data obtained during the tests were also recorded on strip charts. The case drain flow was circulated through the reservoir, to ensure thorough mixing of all the test fluid.

A new or rebuilt pump was used for each test. The throttling valve was used to cycle the main flow rate between 12.5 gpm and 3 gpm, every minute. Fluid samples were drawn from the sampling port. A total of 8 gallons of fluid was initially placed in the stand, and no new fluid was added during the tests.

3.4.1 PUMP TEST WITH FRESH MIL-PRF-83282 (Test 40)

The baseline test, with fresh MIL-PRF-83282 completed the planned 1500 hours. Mid-test inspections were performed after 537 and 1017 hours. The condition of the pump parts at various stages is detailed in Appendix-A and the photographs are shown in Appendix-C.

3.4.2 PUMP TEST WITH PURIFIED MIL-PRF-83282 (Test 41)

Before starting the test, the pump stand was fully prepared (including new filters) and connected to the purifier as shown in Fig 5, using the procedure described in Appendix-B. The pump stand and purifier were filled with fresh MIL-PRF-83282. The purifier was run for 4 hours to circulate the fluid through the test circuit. The circuit was drained and refilled with fresh MIL-PRF-83282. The purifier was run again for 4 hours to circulate the fluid through the test stand. This fluid was sampled for contamination and found to be cleaner than the fresh test fluid. The sub-systems within the test apparatus were set, calibrated, and Test 41 started. During the test, the purifier was disconnected from the pump test stand by closing the shut off valves.

At approximately 200-hour intervals, the test was stopped and the pump test stand was connected to the purifier by opening the shut off valves. The test fluid was circulated through the purifier for 40 minutes. Fluid samples were taken before and after the purification. The exact test hours at which the purification was performed are listed in Table 2.

Test 41, with purified MIL-PRF-83282 also completed the planned 1500 hours. Mid-test inspections were performed after 500 and 923 hours. The condition of the pump parts at various stages is detailed in Appendix-A and the photographs are shown in Appendix-C

4.0 TEST RESULTS

Both the baseline test and the test with purified fluid exhibited similar performances. The test fluid retained its original viscosity throughout the tests (see Figures 7 and 8). No significant difference in pump performance was observed between the two tests.

A number of fluid samples were analyzed for the following:

1. Viscosity
2. Acid Number
3. Water Content
4. Lubricity (4 Ball Wear Test)
5. Metal Content
6. Foaming

Results of the fluid analyses are provided in Tables 1 and 2.

The tests were performed to determine differences, if any, in the functioning of the fluid caused by the Malabar purifier. It was assumed the purifiers do effectively clean the fluid as this has been demonstrated in other purifier tests. Areas of concern were in possible removal of the anti-wear additive, tricresylphosphate, and in possible increase in foaming tendency caused by either removal of antifoam additives or the shearing of the viscosity index improver. During the pump tests, fluid samples were extracted from the operating test stand as the testing progressed. These samples were taken at the approximate intervals listed in Section 3.1. A number of different analyses were conducted on these samples (see Tables 1 and 2).

In all cases, no performance difference was found in fluid samples from either test. The viscosity of the fluid samples taken was determined at 40 °C (see Figures 7 and 8). It is easily seen that MIL-PRF-83282 suffered no viscosity losses during the pump tests, unlike results found with MIL-H-5606 in other pump tests [1], and remained a stable duration both tests. There are no viscosity index (VI) improvers used to boost the viscosity of MIL-PRF-83282 to break up under the high shear environment inside the pump and the throttling valve, as this would cause a permanent loss of the fluid viscosity. Under the high pressure and high shear rate environment, the synthetic PAO fluids do not behave like the (VI) improved base oils.

Water content and acid numbers of the fluid samples were determined and are shown in Tables 1 and 2. Data are very similar.

Samples of the baseline test and samples taken during the purifier test were evaluated for lubricity by 4-ball wear testing ASTM Method D-4172. No differences were seen between the two pump tests. Trace metal analysis was also performed on the fluid samples from the purifier pump test. The samples were analyzed for 19 elements

including Fe, Ag, Cr, Cu, Mg, Na, Ni, Pb, Si, Sn, Ti, Ba, Cd, Mn, Mo, V, and Zn. Only those elements that show concentrations above 0.1 ppm are reported in Table 2. No abnormalities were observed. Foaming was measured in samples from the purifier test. No increase in foaming was observed.

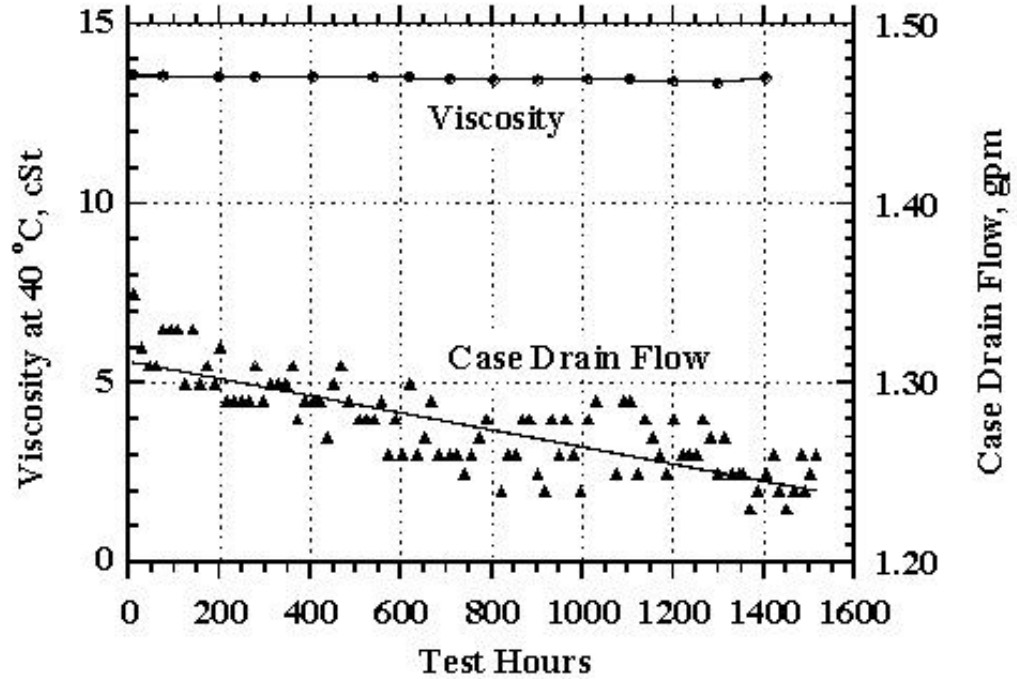

Figure 7. Case Drain Flow and Viscosity for Test 40 with Fresh MIL-PRF-83282

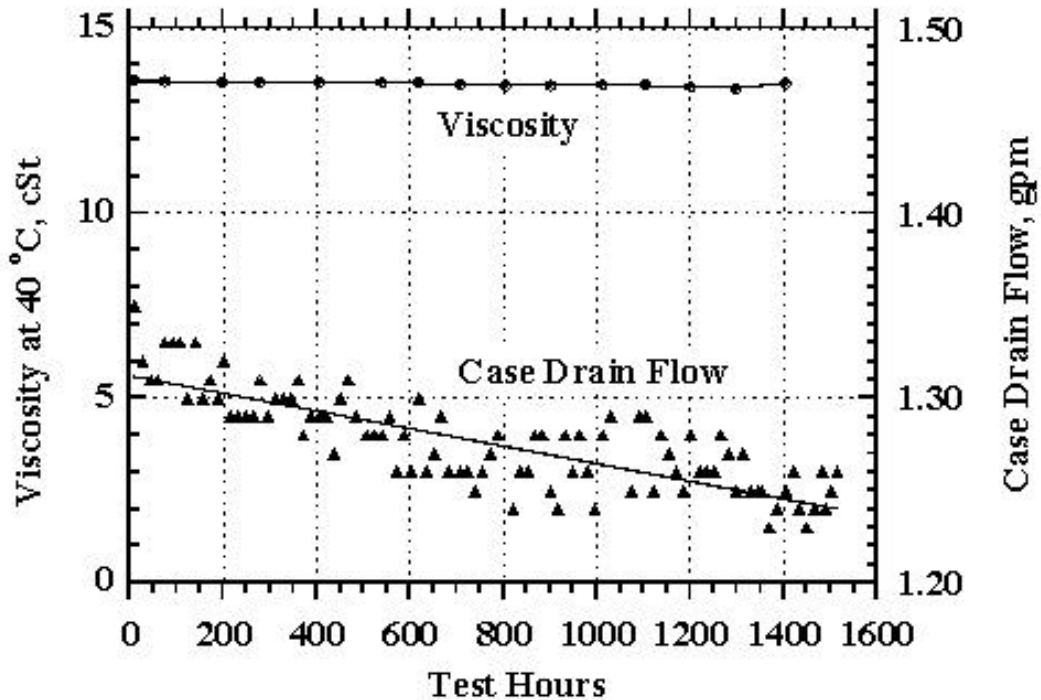

Figure 8. Case Drain Flow and Viscosity for Test 41 with purified MIL-PRF-83282

Table 1. Fluid Analyses, Pump Test #40 with Fresh MIL-PRF-83282

MLO	HOURS	% Air		% 5606	KF Water	Acid	Vis@40°C	Particulate Contamination NAS 1638/Boeing-Navy	Foam Pass/Fail	Four-Ball		ICP (ppm)					
		By GC	By GC	(ppm)	Number	(cSt)	Run 1			Run 2	Fe	Zn	Cu	Pb	Ba	Na	
00-587	Fresh	12.6	0.0	83	0.00	14.32	8/5	pass	0.426	0.43	b	b	b	b	b	b	
01-10	0	11.4	4.4	13	0.00	13.61	4/1	a	a	a	b	b	b	4.5	b	b	
01-11	80	11.9	5.0	40	0.00	13.55	a	a	a	a	b	b	b	3.6	b	b	
01-12	200	a	4.9	37	0.00	13.51	a	a	a	a	b	b	b	2.3	b	b	
01-13	277	a	4.2	48	0.00	13.54	a	a	a	a	b	b	b	1.5	b	b	
01-14	399	a	5.0	49	0.00	13.54	a	a	a	a	b	b	b	b	b	b	
01-15	537	12.5	5.2	43	0.00	13.51	4/0	pass	0.42	0.491	b	b	b	b	b	b	
01-16	611	a	4.7	46	0.00	13.53	a	a	a	a	b	b	b	b	b	b	
01-17	706	a	5.3	52	0.03	13.48	a	a	a	a	b	b	b	b	b	b	
01-18	804	a	5.1	49	0.03	13.45	a	a	a	a	b	b	b	b	b	b	
01-19	900	a	4.7	47	0.03	13.45	a	a	a	a	b	b	b	1.3	b	b	
01-20	1017	a	5.4	48	0.03	13.48	3/0	pass	0.44	0.45	b	b	b	1.6	b	b	
01-21	1109	13.1	5.1	54	0.03	13.48	a	a	a	a	b	b	b	b	b	b	
01-22	1204	13.9	5.1	65	0.00	13.41	a	a	a	a	b	b	b	b	b	b	
01-23	1301	a	5.6	66	0.03	13.37	a	a	a	a	b	b	b	b	b	b	
01-24	1402	a	5.2	117	0.00	13.49	a	a	a	a	b	b	b	b	b	b	
01-25	1514	a	5.1	67	0.00	13.45	6/3	pass	0.442	0.445	b	b	b	b	b	b	

a = not determined
b = not detectable

Table 2. Fluid Analyses, Pump Test #41 with Purified MIL-PRF-83282

MLO	HOURS	% Air		% 5606	KF Water	Acid	Vis@40°C	Particulate Contamination NAS 1638/Boeing-Navy	Foam Pass/Fail	Four-Ball		ICP (ppm)					
		By GC	By GC	(ppm)	Number	(cSt)	Run 1			Run 2	Fe	Zn	Cu	Pb	Ba	Na	
00-587	Fresh	~14	<0.5	83	0.00	14.32	8/5	pass	0.426	0.43	b	b	b	b	b	b	
01-26	Rinse	a	<0.5	23	0.00	14.24	7/3	a	a	a	b	b	b	b	b	b	
01-266	0	10.5	<0.5	25	0.00	14.24	3/0	a	a	a	b	b	b	2.1	b	b	
01-267	122	~15	<0.5	177	0.00	14.28	a	a	a	a	a	a	a	a	a	a	
01-268	151	~12	a	118	0.00	14.28	a	a	a	a	a	a	a	a	a	a	
01-269	175.9 ^c	1.5	a	30	a	a	a	a	a	a	a	a	a	a	a	a	
01-270	250.8	7	a	67	0.08	14.26	a	a	a	a	a	a	a	a	a	a	
01-271	377.6 ^d	~13	a	56	0.03	13.97	a	a	a	a	a	a	a	a	a	a	
01-272	377.6 ^c	3.2	a	32	0.0	14.31	a	a	a	a	a	a	a	a	a	a	
01-273	500	8.6	0.2	48	0.0	14.25	2/0	pass	0.46	0.45	b	b	b	b	b	b	
01-274	638	~13	0.2	43	0.0	14.21	a	a	a	a	a	a	a	a	a	a	
01-275	638.2 ^c	~6	a	17	a	a	a	a	a	a	a	a	a	a	a	a	
01-276	761.9	~13.1	a	161	a	a	a	a	a	a	a	a	a	a	a	a	
01-277	761.9 ^c	~6.1	a	25	a	a	a	a	a	a	a	a	a	a	a	a	
01-278	900.0	~9.8	a	41	a	a	a	a	a	a	a	a	a	a	a	a	
01-279	1182.53 ^c	~13.3	a	19	0.08	14.17	2/0	pass	a	a	b	b	b	b	b	b	
01-280	1183.93 ^c	~9.8	a	15	a	a	a	a	a	a	a	a	a	a	a	a	
01-281	1415.63 ^c	~9.3	a	52	0.03	14.22	a	a	a	a	a	a	a	a	a	a	
01-629	1415.68 ^c	~4.1	a	37	a	a	a	a	a	a	a	a	a	a	a	a	
01-638	1504.3	~4.6	0.4	23	0.08	14.19	4/1	pass	0.51	0.51	b	b	b	b	b	b	

a = not determined
b = not detectable
c = after 40 minutes of purification
d = after pump stand shut down due to power outage

5.0 CONCLUSIONS

Pump tests with both fresh and purified MIL-PRF-83282 fluids were successfully completed, and there was no apparent difference in pump performance with either fluid. No adverse effects were observed on the pump specimens or the fluid properties. Polishing wear and minor erosion on the cylinder block face and on the piston-shoe faces were observed. The wear on the piston shoe faces or cylinder block was not any different with the purified fluid than observed in the test with fresh MIL-PRF-83282. There was no viscosity loss in both the fresh and the purified fluid tests. There was no significant change in the other fluid properties monitored.

The Malabar purifier performed as expected concerning reduction of water content and particulate removal. Dissolved air content was reduced as well, and this did not decrease pump performance or pump life. There is no indication the Malabar prototype purifier design tested may cause negative effects to similar aircraft hydraulic pumps or to MIL-PRF-83282.

6.0 REFERENCES

1. Sharma S.K., Snyder, C.E., Jr. and Gschwender, L.J., Cecere, G.J., and Jenney, T.A., "Endurance Pump Tests with Fresh and Purified MIL-H-5606 Hydraulic Fluid," AFRL-ML-WP-TR-1998-4211, (1998)
2. Sharma S.K., Snyder, C.E., Jr. and Gschwender, L.J., Cecere, G.J., and Jenney, T.A., "Endurance Pump Tests with Fresh and Purified MIL-PRF-83282 Hydraulic Fluid," AFRL-ML-WP-TR-1999-4185, (1999)

7.0 ACKNOWLEDGMENTS

Funding for this work was provided by ASC/AAC. The support provided by Malabar International, Mr. Jeffrey Haford and Mr. Gregory Palm of Southwestern Ohio Council of Higher Education is gratefully acknowledged.

Appendix A: Inspection Reports, Test 40

A1. Test 40, 537 Hours

- a) Light wear on the inner race of the valve plate bearing
- b) The valve plate surface appears almost new except for one shallow irregular cavitation pit measuring appx 2.5 mm radially and 0.7 mm tangentially, found roughly midway between the inlet and outlet ports on the piston recharging side.
- c) Typical kidney port erosion of the cylinder block has barely started on the outer trailing edge of the kidney ports.
- d) The yoke boss, both yoke trunion bearings, the hold down plate retainer, the drive shaft inner splines, the drive shaft bearing, and carbon seal appear virtually new.
- e) The shoes are very clean, showing no cavitation damage and appear like new. Very mild polishing on the outer shoe perimeter. Each shoe was dimensioned for ball joint endplay and shoe flange thickness.
- f) The torque coupler mating splines on the external coupling shaft show mild wear, but are not a function of test fluid performance or of the lubricating grease.
- g) The pistons do not show any scuffing or wear.

All remaining internal critical surfaces, as well as internal cavities, show no debris deposits and wear.

A2. Test 40, 1017 Hours

- a) The yoke boss shows faint linear abrasion marks parallel to the central bearing axis on the support tangs for the trunion bearing inner races, but is otherwise blemish free. These marks have been seen on other test specimens and should not affect bearing performance.
- b) The hold down plate retainer has less than normal tarnish on the exposed side, while appearing new on the clamping face minus a few minor solitary scratches and a faint scuff of unknown origin.
- c) The shoes are very clean, showing no cavitation damage and appear close to new, except for mild axial marks on the outside periphery of the gimbal ball joint sockets. This is caused from contact with the piston shoe retaining plate. Very gentle polishing on the outer shoe perimeter is almost indiscernible from new. Each shoe was dimensioned for ball joint endplay and shoe flange thickness, showing typical change in dimensions listed below.
- d) The torque coupler mating splines (on the external coupling shaft) show no difference in the existing fretting.
- e) Contact frosting on the inner race of the valve plate bearing persists, and is almost unaffected from the additional testing. Some shaft tarnish between the splines and the inner race was observed.
- f) No change in the valve plate surface occurred. This surface appears almost new except for the same shallow irregular cavitation pit noted before, which showed no growth, found roughly midway between the inlet and outlet ports on the piston recharging side.

- g) The mild cavitation erosion located on the outer trailing edge of the cylinder block kidney ports has not increased since last inspection.
- h) The drive shaft inner splines have developed light fretting patterns.
- i) Both yoke trunion bearings have excellent rolling surfaces; but the rollers in the bearing closest to the case drain port display crescent profile polish marks, found on the edges of both sides of those rollers. This is caused from the rollers rocking while encumbered against the containment edges of the bearing races.
- j) The driveshaft bearing and carbon seal appear virtually new.
- k) The pistons still do not show any noticeable increase in polishing or scuffing.
- l) The actuator piston finally revealed a minute circular polishing mark in the extreme center of the contact surface, overall much less wear than in previous tests at this interval.

All remaining internal critical surfaces, as well as internal cavities, show no debris deposits and imperceptible wear.

A3. Test 40, 1515 Hours

Upon achieving 1515 hours, Test 40 was stopped for pump inspection. When removed from the stand, disassembled, photographed, measured, and compared to the 1017 hours pump inspection; the 1515 hours inspection shows:

- a) The mild cavitation erosion located on the outer trailing edge of the cylinder block kidney ports has not increased since last inspection.
- b) The shoes are very clean, showing no cavitation damage and appear close to new, except for polished axial fretting marks on the outside periphery of the gimbal ball joint sockets. The original tooling pattern is still visible on the shoe faces. Very gentle polishing on the outer shoe perimeter is almost indiscernible from new. Each shoe was dimensioned for ball joint endplay and shoe flange thickness, showing typical change in dimensions listed below.
- c) The pistons barely show faint polishing
- d) Mild contact frosting on the inner race of the valve plate bearing appears to have healed slightly since the last inspection. Additional shaft tarnish between the splines and the inner race was observed. The drive shaft inner splines have the same light fretting patterns; while the drive shaft bearing and carbon seal appear virtually new.
- e) No change in the valve plate surface occurred. This surface appears almost new except for the same shallow irregular cavitation pit noted before, which showed no additional growth, found roughly midway between the inlet and outlet ports on the piston recharging side.
- f) The hold down plate retainer remains clean with minor coloration on the exposed side, seen surrounding the SHC screw holes that flank the trunion bearings. Overall, it has less than normal tarnish, while appearing the same as before on the clamping face.
- g) When compared to the previous inspection, the yoke boss shows noticeably reduced faint linear abrasion marks, parallel to the central bearing axis, on the tangs for the trunion bearing inner races.

- h) Both yoke trunion bearings have excellent rolling surfaces; but the rollers in the bearing closest to the case drain port still display the crescent profile polish marks (unchanged), found on the edges of both sides of those rollers.
- i) The actuator piston's minute circular polishing mark in the extreme center of the contact surface has started to broaden, overall much less wear than in previous tests at this interval.
- j) The torque coupler mating splines on the external coupling shaft do not show any difference in the existing fretting.

All remaining internal critical surfaces, as well as internal cavities, show no debris deposits and imperceptible wear.

Table 3. Ball Joint Play and Shoe Flange Thickness – Test 40

VICKERS PV3-075-15 SERIAL NUMBER MX346554

*Ball Joint Play
(inches)*

<i>Piston</i>	537 Hr.	1017 Hr.	1515 Hr.
1	0.0014	0.0014	0.0026
2	0.0012	0.0012	0.002
3	0.0021	0.0022	0.0016
4	0.0028	0.0028	0.0011
5	0.0007	0.0007	0.0019
6	0.0004	0.001	0.0019
7	0.0011	0.0012	0.0052
8	0.0008	0.0011	0.0045
9	0.0011	0.0013	0.0025

*Shoe Flange Thickness
(inches)*

<i>Piston</i>	537 Hr.			1017 Hr.			1515 Hr.		
	120 deg.	240 deg.	360 deg.	120 deg.	240 deg.	360 deg.	120 deg.	240 deg.	360 deg.
1	0.1406	0.1406	0.1407	0.1406	0.1406	0.1407	0.1411	0.1408	0.1404
2	0.1406	0.1404	0.1405	0.1406	0.1404	0.1405	0.1409	0.1411	0.1405
3	0.1406	0.1402	0.1406	0.1404	0.1402	0.1406	0.1403	0.1409	0.1407
4	0.1408	0.1404	0.1408	0.1405	0.1404	0.1408	0.1405	0.1408	0.1406
5	0.1413	0.1407	0.1407	0.1409	0.1406	0.1406	0.1405	0.141	0.1417
6	0.1409	0.1405	0.1414	0.1409	0.1405	0.1411	0.1406	0.1416	0.1412
7	0.1404	0.1404	0.141	0.1404	0.1403	0.1408	0.1406	0.1407	0.1404
8	0.1403	0.1405	0.141	0.1403	0.1405	0.1409	0.1403	0.1405	0.141
9	0.1404	0.1406	0.1408	0.1404	0.1406	0.1405	0.1407	0.1408	0.1406

Appendix B: Inspection Reports, Test 41

B1. Test 41, 500 Hours

- a) The valve plate surface appears almost new except for one shallow irregular cavitation pit. This pit is very similar to the Test 40 specimen valve plate at the 537-hour inspection.
- b) Kidney port erosion of the cylinder block has started on the outer trailing edge of the kidney ports. This erosion tends to be wider than it is deep.
- c) The yoke boss is in excellent condition, with minor polishing of the bearing plate. The trunion bearing tangs and mating foot for the actuator piston are almost pristine. The actuator piston face has radial polishing wear.
- d) Both yoke trunion bearings are outstanding. Just a few of the case drain port side bearing rollers have mild crescent shaped contact marks on the flats. These marks were also seen in the Test 40 specimen bearings.
- e) The hold down plate retainer has typical rotation markings from the piston shoe retaining plate, unchanged from the pre-test inspection. The beginning of mild tarnish on this same side was observed.
- f) The drive shaft inner splines appear as good as pre-test condition and the drive shaft bearing and carbon seal appear virtually new.
- g) The shoes are very clean, showing no cavitation damage and appear more or less new. Very mild polishing on the outer shoe perimeter is almost indiscernible from new. Each shoe was dimensioned for ball joint endplay and shoe flange thickness.
- h) The torque coupler mating splines (on the external coupling shaft) show minimal wear, but are not a function of test fluid performance or of the lubricating grease.
- i) The pistons show a faint increase in polishing.
- j) All remaining internal critical surfaces, as well as internal cavities, show no debris deposits and imperceptible wear.

B2. Test 41, 923 Hours

- a) No appreciable wear on the inner race of the valve plate bearing
- b) A small cavitation erosion pit has formed near the existing shallow irregular cavitation pit. Otherwise, the valve plate surface appears almost new.
- c) Little change has occurred to the minor kidney port erosion of the cylinder block that started on the outer trailing edge of the kidney ports. This erosion tends to be wider than it is deep.
- d) The yoke boss is in excellent condition, with minor polishing of the bearing plate. The pintle bearing tangs and mating foot for the actuator piston are almost unworn. The actuator piston face shows additional radial polish wear.
- e) Both yoke pintle bearings look good. Just a few of the case drain port side bearing rollers have mild crescent shaped contact marks on the flats. These marks were also seen in the 500-hour inspection and on the Test 40 bearings.

- f) The hold down plate retainer has typical rotation marks from the piston shoe retaining plate, virtually unchanged from the 500-hour inspection. The mild tarnish on this same side was observed to be essentially identical as before.
- g) The drive shaft inner splines appear as good as the 500-hour condition and the drive shaft bearing and carbon seal appear virtually new.
- h) The shoes are very clean, showing no cavitation damage and appear more or less new. Very mild polishing over the face of each shoe is almost indiscernible from new. Each shoe was dimensioned for ball joint endplay and shoe flange thickness. The dimensional differences for shoe flange thickness have decreased measurably.
- i) The torque coupler mating splines on the external coupling shaft show minimal wear, but are not a function of test fluid performance or of the lubricating grease.
- j) The pistons show a faint increase in polishing, just reducing the pre-existing scuffs.
- k) All remaining internal critical surfaces, as well as internal cavities, show no debris deposits and imperceptible wear.

B3. Test 41, 1504 Hours

- a) The shoes are very clean, showing no cavitation damage and appear more or less new. Very mild polishing over the face of each shoe is almost indiscernible from new. Each shoe was dimensioned for ball joint endplay and shoe flange thickness. The dimensional differences for shoe flange thickness have stopped decreasing measurably.
- b) The pistons show a small increase in polishing, banded in the lower half of the length. The hold down plate retainer has typical rotation striations from the piston shoe retaining plate, virtually unchanged from the last inspection. The mild tarnish on this same side was observed to be essentially identical as before.
- c) No appreciable wear on the inner race of the valve plate bearing is evident.
- d) The valve plate surface still appears almost new, except for the small cavitation pit and earlier formed shallow irregular cavitation pit, which have hardly changed.
- e) On the cylinder block, the outer trailing edge kidney port erosion continued to grow wider than deep, in some areas almost reaching the groove separating the pads from the kidney port face.
- f) The yoke boss is in excellent condition. Partial polishing of the bearing plate is highlighted from the mild olive green tarnish in the no-contact zones. The ball bearing in the yoke boss is free of any perceptible wear. The pintle bearing tangs and mating foot for the actuator piston remain almost unworn.
- g) The actuator piston face shows fairly uniform additional radial polish wear, implying some rotation occurred during use. Both yoke pintle bearings are clean and roll freely.
- h) Some of the case drain port side bearing rollers have crescent shaped contact marks on the flats.
- i) The drive shaft inner splines appear excellent, with almost no visible fretting. The condition of the drive shaft bearing and carbon seal appear virtually new.
- j) The torque coupler mating splines (on the external coupling shaft) show no additional wear.

- k) The remaining internal critical surfaces like the compensator assembly, the control guide and springs, as well as the housing and mounting flange show no debris deposits or discernible wear.

Table 4

**VICKERS PV3-075-15 SERIAL NUMBER MX433348
TEST 41**

***Ball Joint Play
(inches)***

<i>Piston</i>	500 Hr.	923 Hr.	1504 Hr.
<i>1</i>	0.004	0.0037	0.0038
<i>2</i>	0.0014	0.0013	0.0014
<i>3</i>	0.004	0.0038	0.0037
<i>4</i>	0.0016	0.0014	0.0015
<i>5</i>	0.0011	0.0012	0.0012
<i>6</i>	0.001	0.001	0.001
<i>7</i>	0.0011	0.0014	0.0014
<i>8</i>	0.0014	0.0034	0.003
<i>9</i>	0.0034	0.0011	0.0015

***Shoe Flange Thickness
(inches)***

<i>Piston</i>	500 Hr.	500 Hr.	500 Hr.	923 Hr.	923 Hr.	923 Hr.	1504 Hr.	1504 Hr.	1504 Hr.
	120 deg.	240 deg.	360 deg.	120 deg.	240 deg.	360 deg.	120 deg.	240 deg.	360 deg.
<i>1</i>	0.1425	0.1423	0.1424	0.1423	0.1422	0.1423	0.1422	0.1424	0.1422
<i>2</i>	0.1421	0.1421	0.1422	0.142	0.1421	0.142	0.142	0.142	0.1421
<i>3</i>	0.1429	0.1424	0.1423	0.1421	0.1422	0.1423	0.1422	0.1422	0.1422
<i>4</i>	0.1419	0.1422	0.1424	0.1421	0.1421	0.1421	0.1421	0.1421	0.1421
<i>5</i>	0.1422	0.1426	0.1417	0.1418	0.1421	0.1419	0.1419	0.1421	0.1421
<i>6</i>	0.1423	0.142	0.1419	0.1421	0.1423	0.1421	0.142	0.1422	0.1422
<i>7</i>	0.1419	0.1422	0.142	0.142	0.1421	0.142	0.1421	0.1421	0.1421
<i>8</i>	0.1425	0.1422	0.141	0.1421	0.1421	0.1422	0.1421	0.142	0.1421
<i>9</i>	0.1422	0.1417	0.1417	0.1419	0.1418	0.1419	0.1418	0.142	0.142

APPENDIX C, Purifier/Pump Stand Interface for Test 41

1. Bleed stand.
2. Charge stand to 15 PSIG.
3. Start purifier.
4. Open purifier ball valves for inlet and outlet.
5. Crack shunt valve to half open.
6. Open isolation valves to full flow.
7. Open pump bypass and throttle valve bypass valves to full open.
8. Close separation valve.
9. Open filter bypass valves (improves main flow rate through stand).
10. Observe pump pressure gauge for stability and ranged 70 to 80 PSIG.
11. Open spray flow valve VERY slowly to 0.35 to 0.5 GPM
12. Spray flow rate meter should be stable.
13. Outlet pressure gauge should read near 0 PSIG.
14. Decrease shunt valve flow to limit of stability seen in 10, 12, and 13.
15. When spray valve is open too much, or reservoir pressure gauge shows >15PSIG, the tank level of the purifier must be dropped below upper level limit. Closing the spray valve will pump the level down, but the reservoir pressure must be dumped until finished, then returned to 15 PSIG.

APPENDIX D

Photos from Pump Test with Fresh and Purified MIL-PRF-83282 (Test 40 and Test 41)

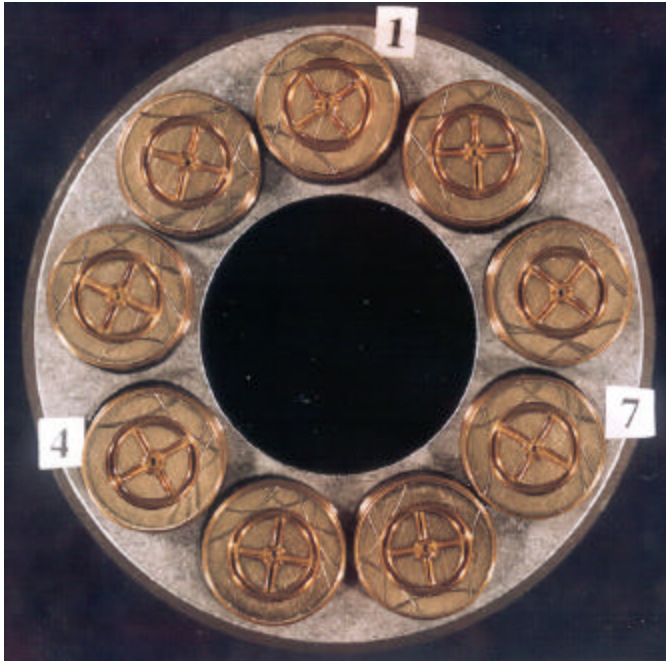

All Shoe Faces at Pretest
Fresh Fluid

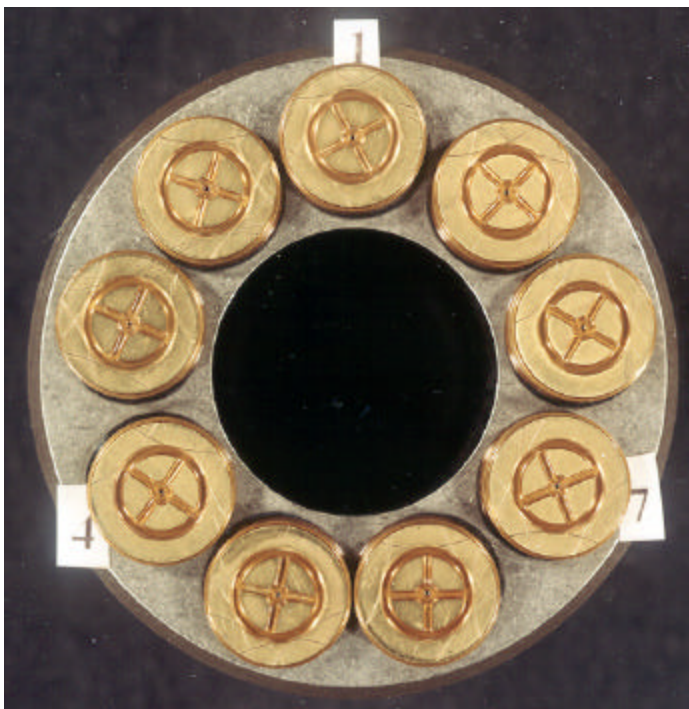

Actuator Piston at 1515 Hours
Fresh Fluid

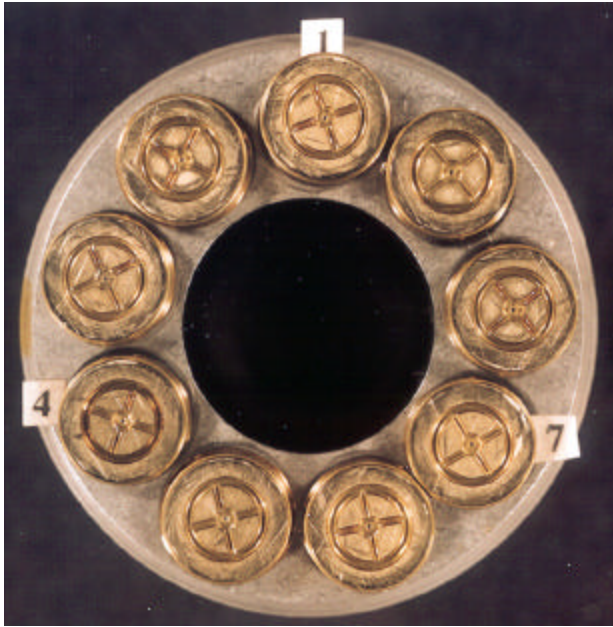

Piston Shoe Faces at Pretest
Purified Fluid

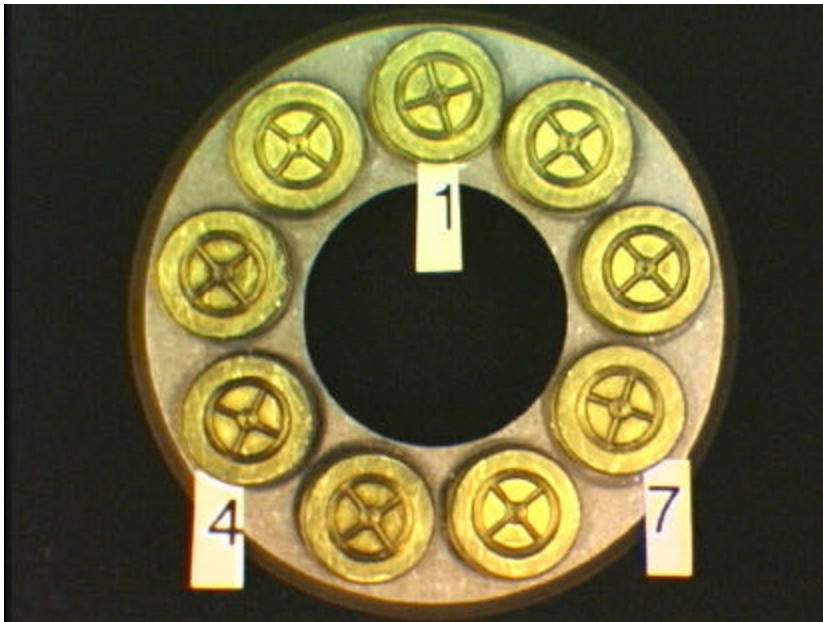

Piston Shoe Faces at 1500 Hours
Purified Fluid

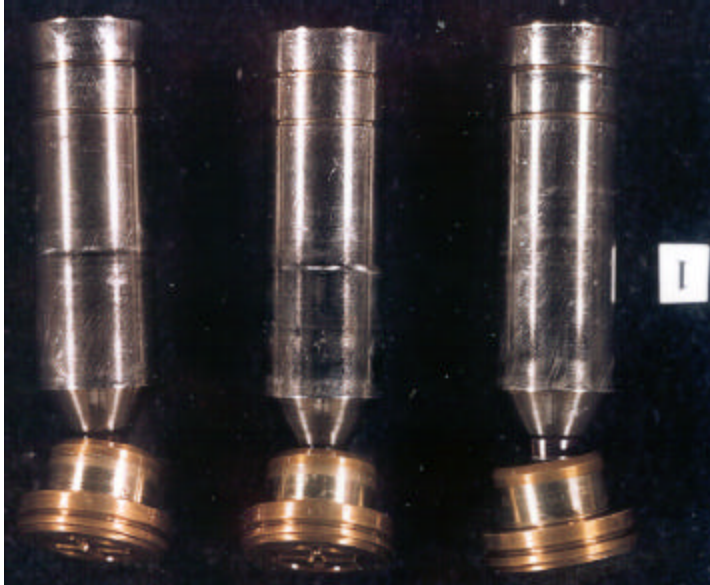

Pistons 1-3 at Pretest
Fresh Fluid



Pistons 1-3 at 1515 Hours
Fresh Fluid



Pistons 1-3 at Pretest
Purified Fluid



Pistons 1-3 at 1500 Hours
Purified Fluid



Pistons 4-6 at Pretest
Fresh Fluid



Pistons 4-6 at 1515 Hours
Fresh Fluid



Pistons 4-6 at Pretest
Purified Fluid



Pistons 4-6 at 1500 Hours
Purified Fluid



Pistons 7-9 at Pretest
Fresh Fluid



Pistons 7-9 at 1515 Hours
Fresh Fluid



Pistons 7-9 at Pretest
Purified Fluid



Pistons 7-9 at 1500 Hours
Purified Fluid

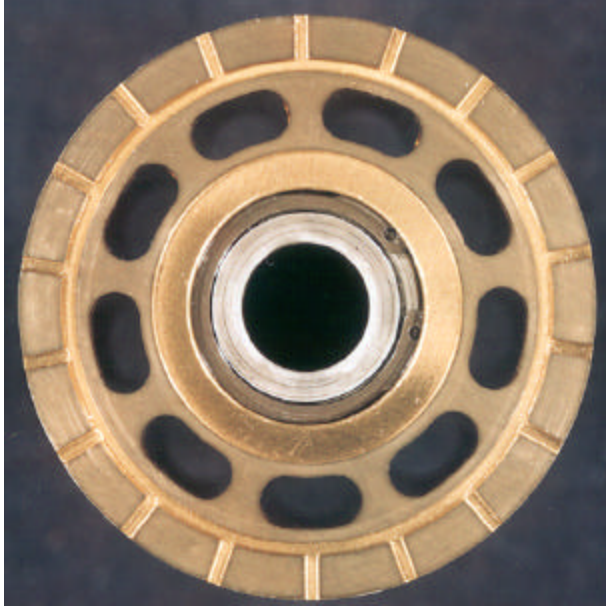

Cylinder Block Face at Pretest
Fresh Fluid

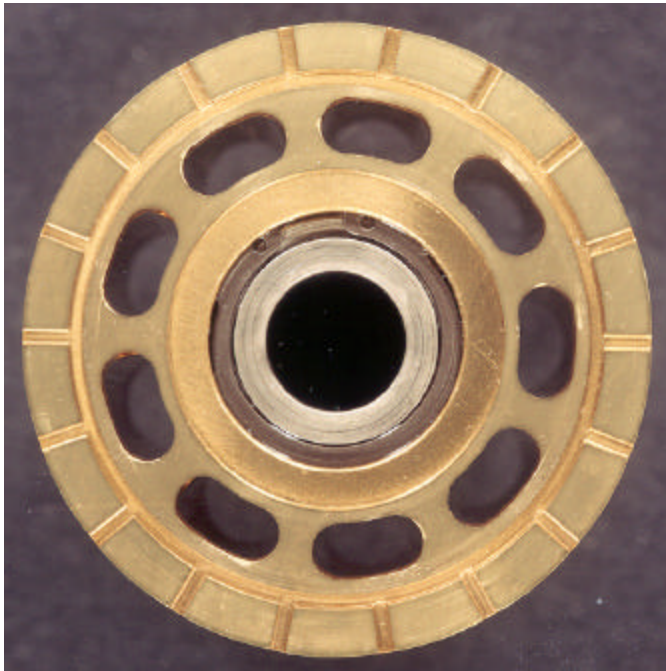

Cylinder Block Face at 1515 Hours
Fresh Fluid

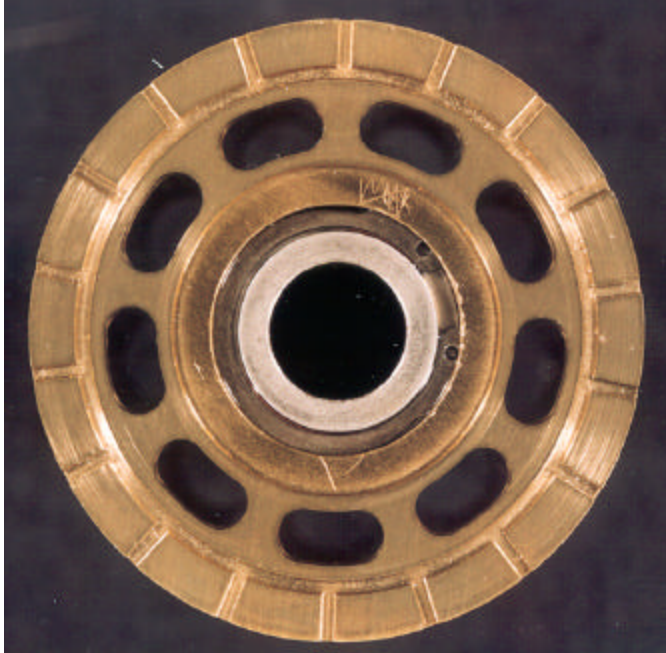

Cylinder Block Face at Pretest
Purified Fluid

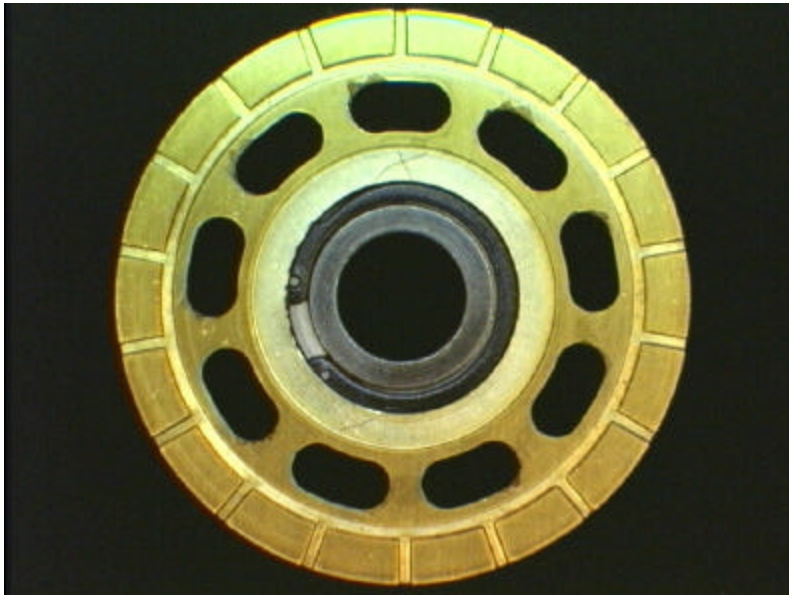

Cylinder Block Face at 1500 Hours
Purified Fluid

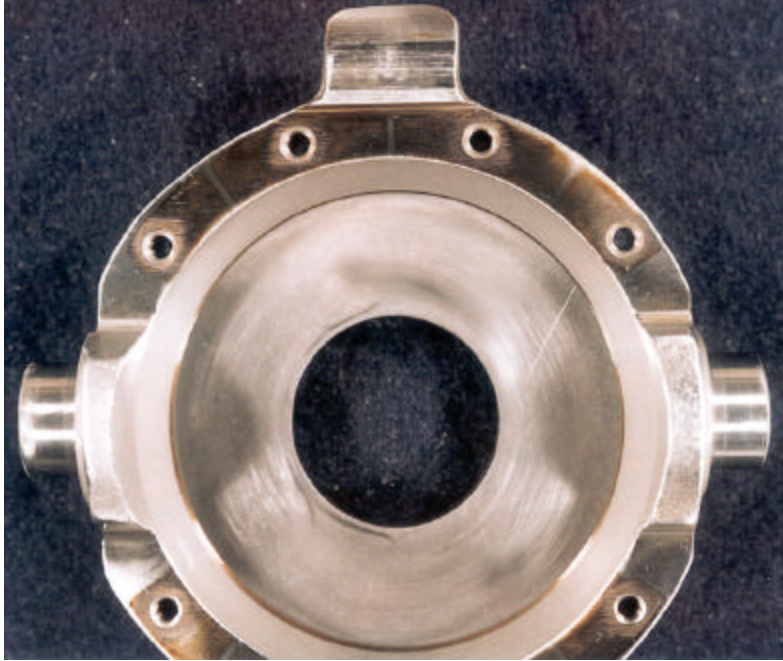

Yoke at Pretest
Fresh Fluid

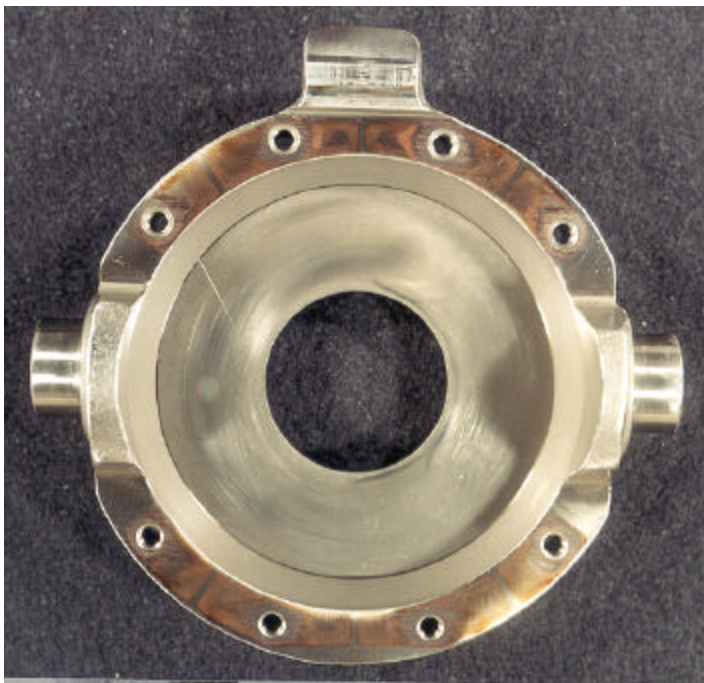

Yoke at 1515 Hours
Fresh Fluid

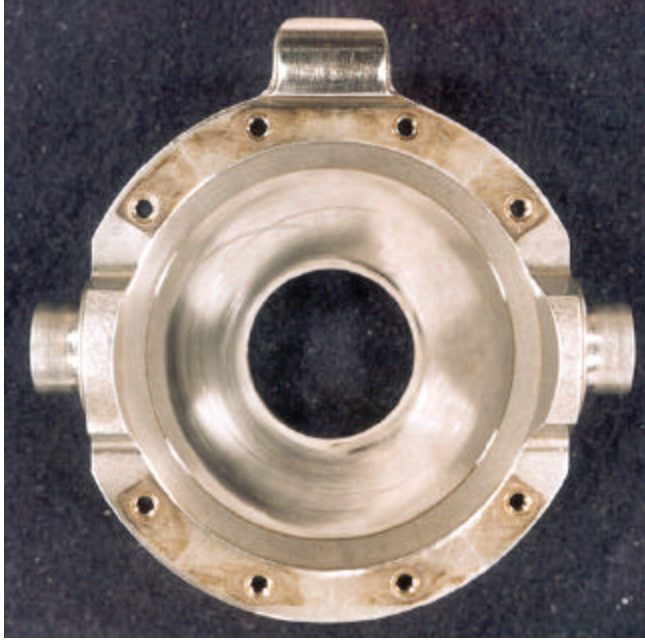

Yoke at Pretest
Purified Fluid

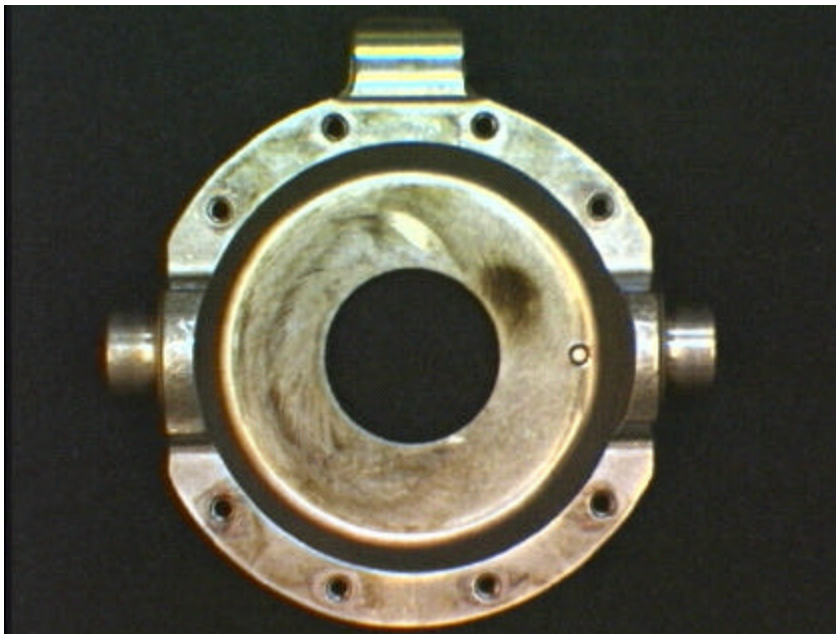

Yoke at 1500 Hours
Purified Fluid

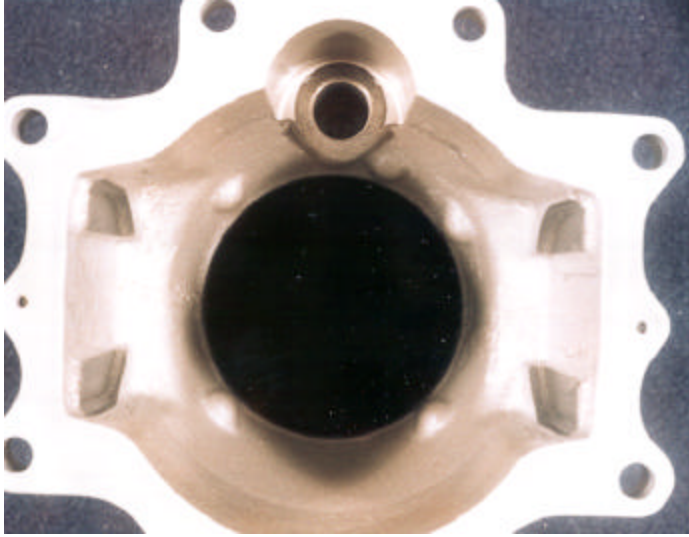

Housing at Pretest
Fresh Fluid

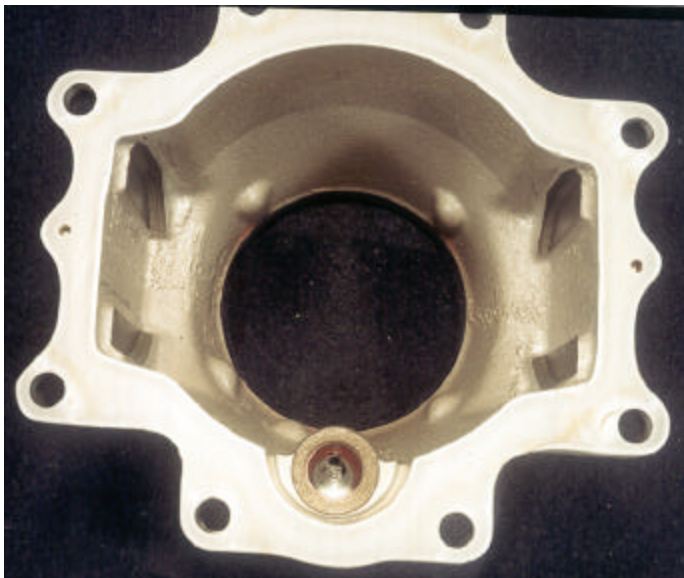

Housing at 1515 Hours
Fresh Fluid

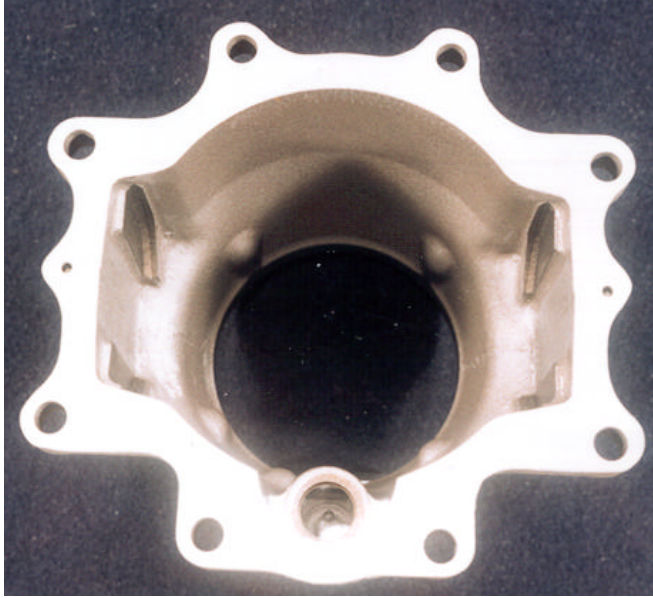

Housing at Pretest
Purified Fluid

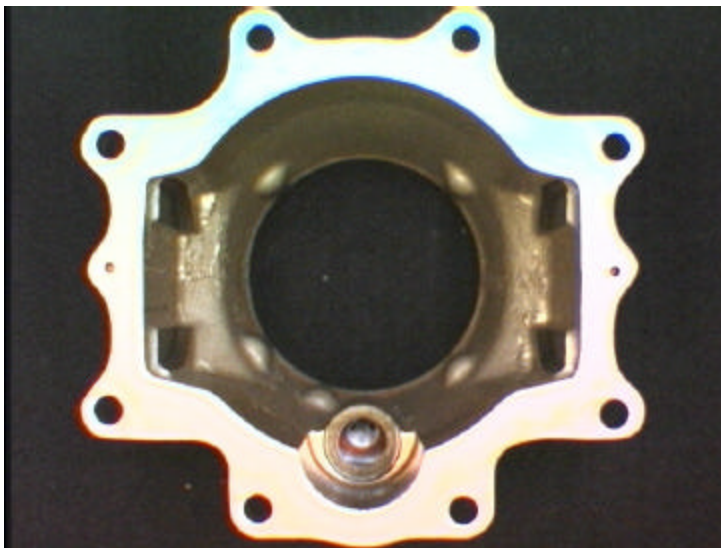

Housing at 1500 Hours
Purified Fluid

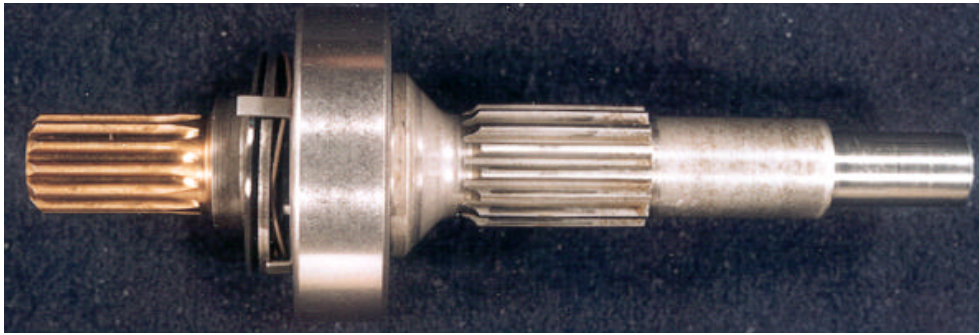

Shaft at Pretest
Fresh Fluid

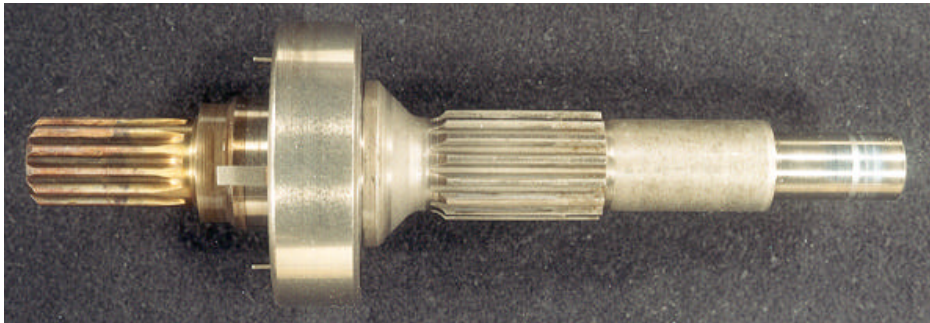

Shaft at 1515 Hours
Fresh Fluid

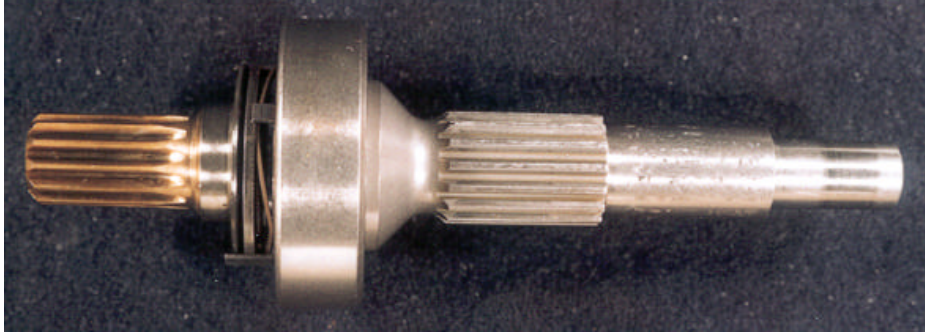

Shaft at Pretest
Purified Fluid



Shaft at 1500 Hours
Purified Fluid

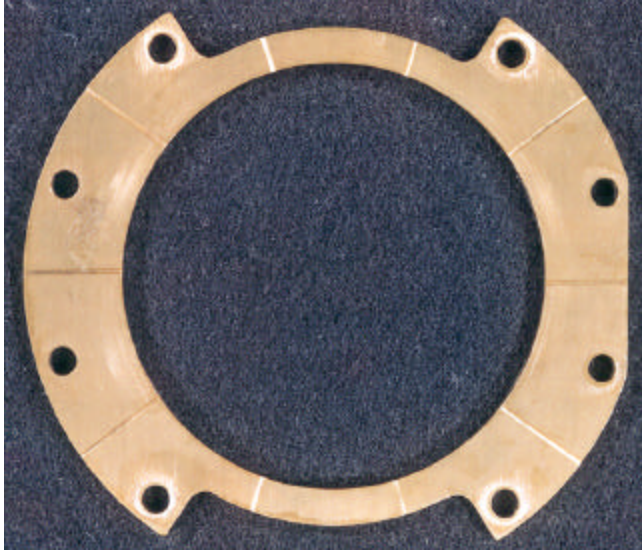

Rub Plate at Pretest
Fresh Fluid

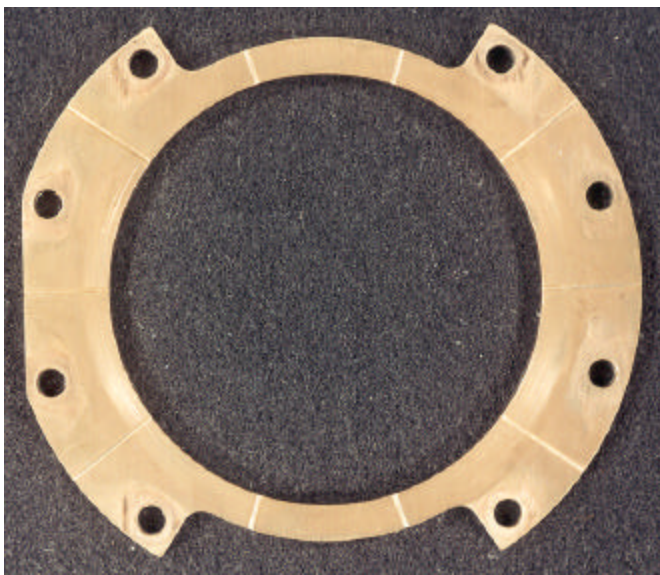

Rub Plate at 1515 Hours
Fresh Fluid

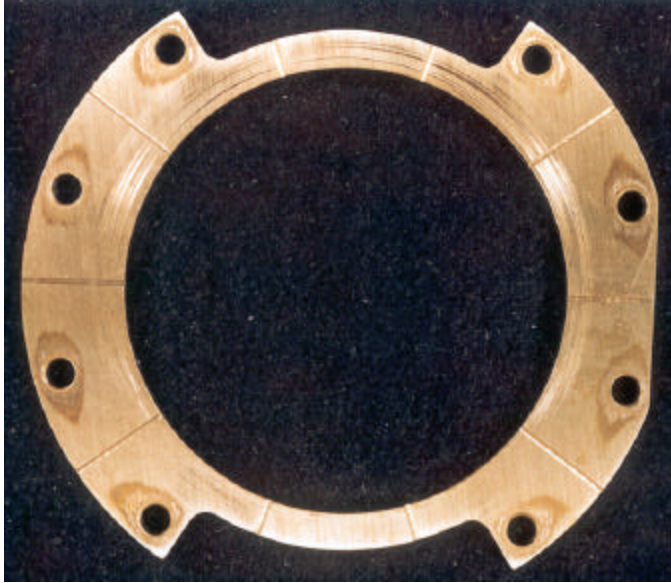

Rub Plate at Pretest
Purified Fluid

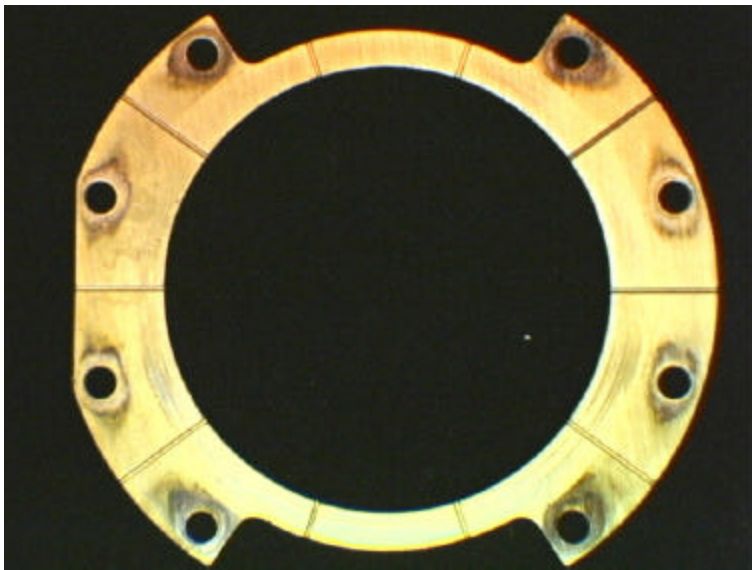

Rub Plate at 1500 Hours
Purified Fluid

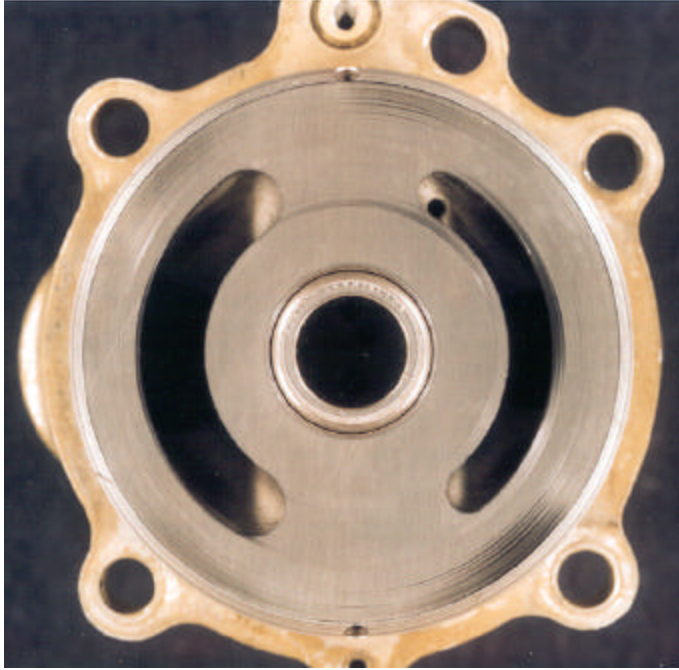

Valve Plate at Pretest
Fresh Fluid

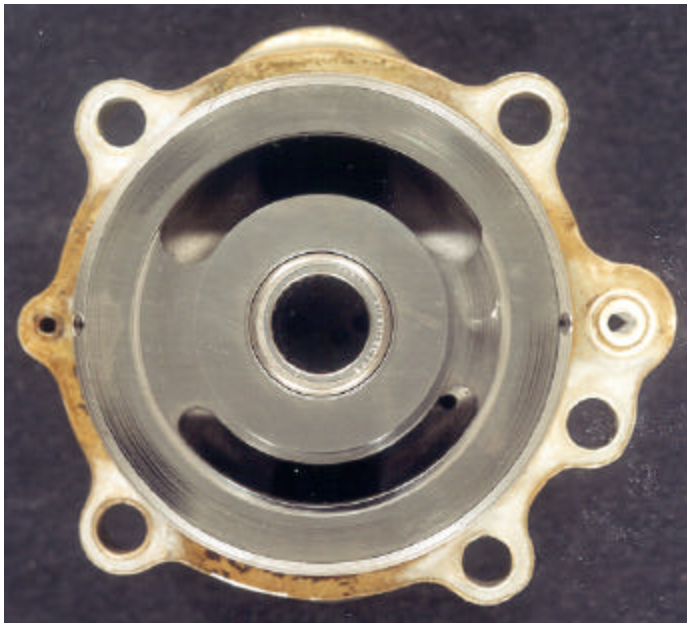

Valve Plate at 1515 Hours
Fresh Fluid

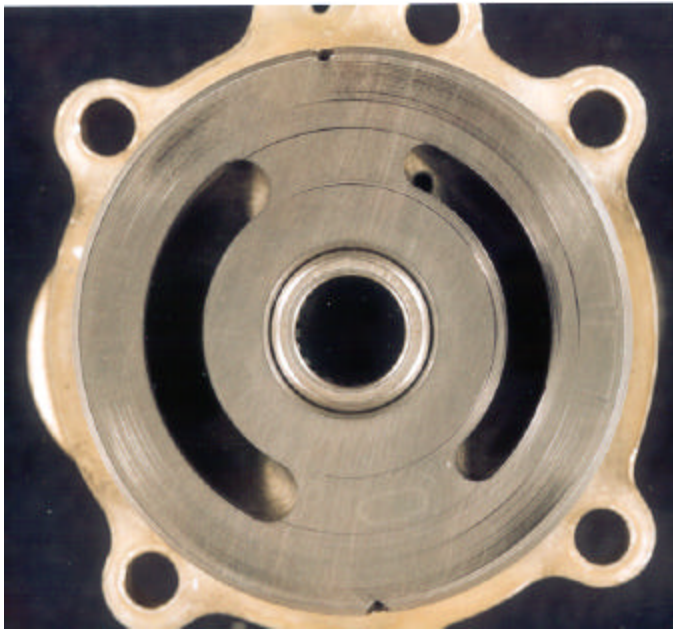

Valve Plate at Pretest
Purified Fluid

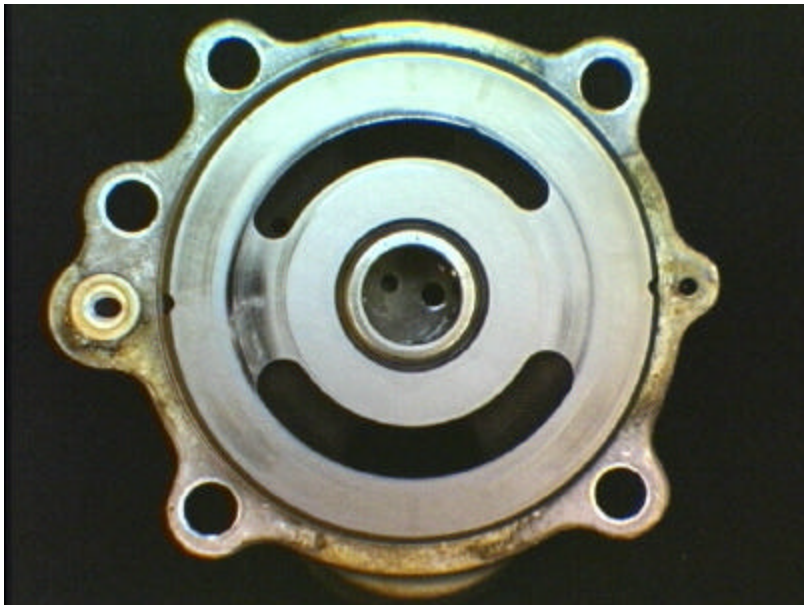

Valve Plate at 1500 Hours
Purified Fluid



Yoke Pintle Bearings at Pretest
Fresh Fluid



Yoke Pintle Bearings at 1515 Hours
Fresh Fluid
[white square denotes case drain outlet side]



Pintle Bearings at Pretest
Purified Fluid



Pintle Bearings at 1500 Hours
Purified Fluid
[white square denotes case drain outlet side]

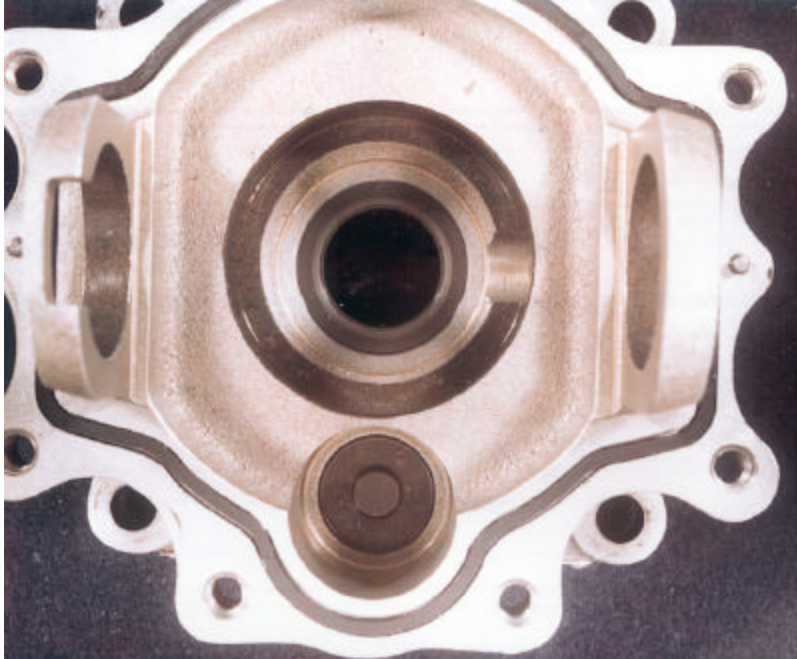

Mounting Flange at Pretest
Fresh Fluid

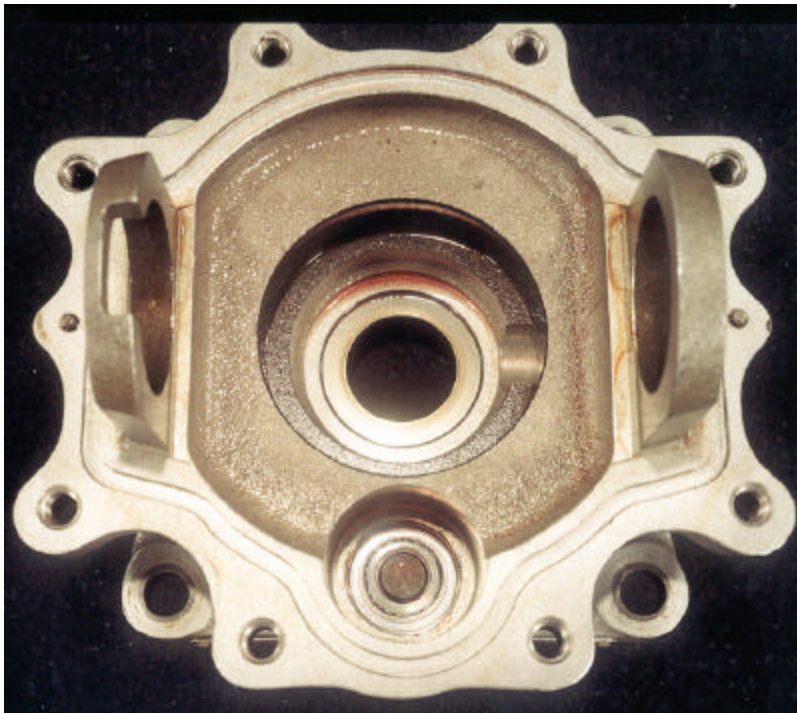

Mounting Flange at 1515 Hours
Fresh Fluid

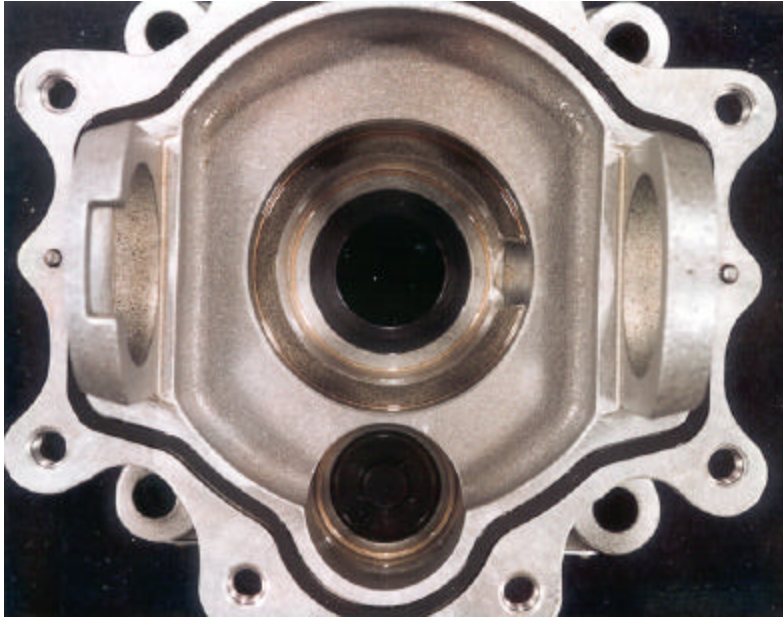

Mounting Flange at Pretest
Purified Fluid

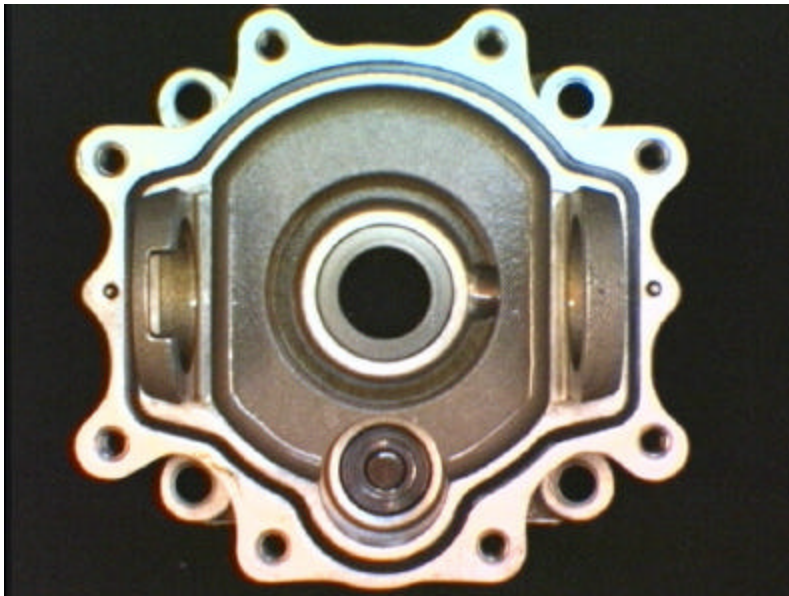

Mounting Flange at 1500 Hours
Purified Fluid

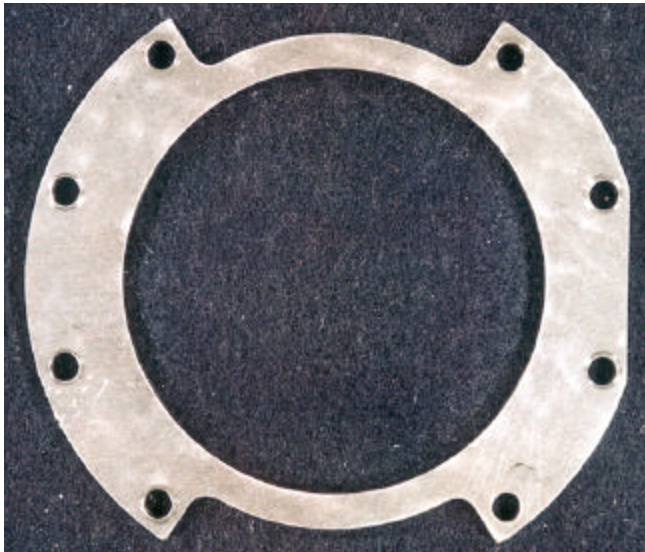

Nonrub Plate at Pretest
Fresh Fluid

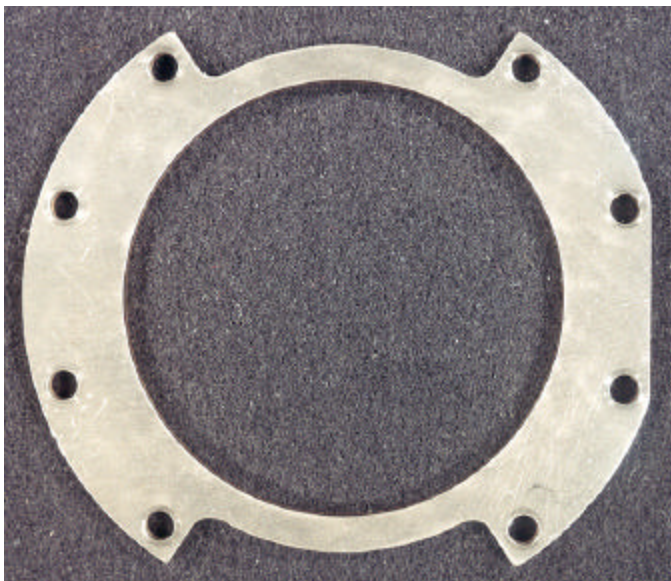

Nonrub Plate at 1515 Hours
Fresh Fluid

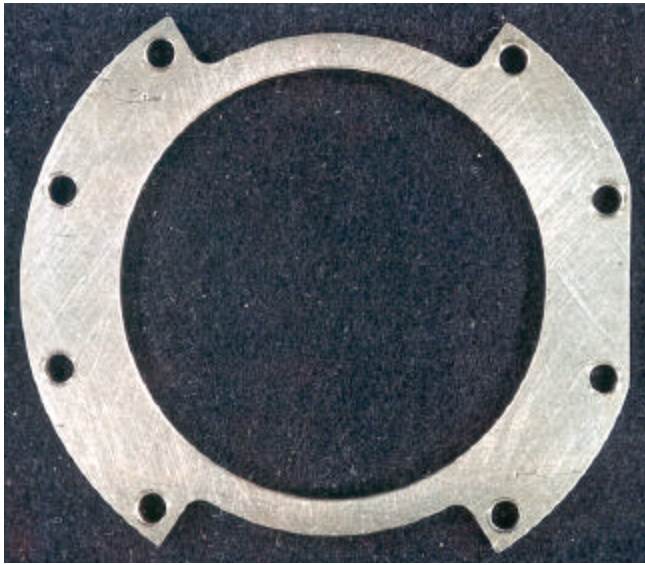

Nonrub Plate at Pretest
Purified Fluid

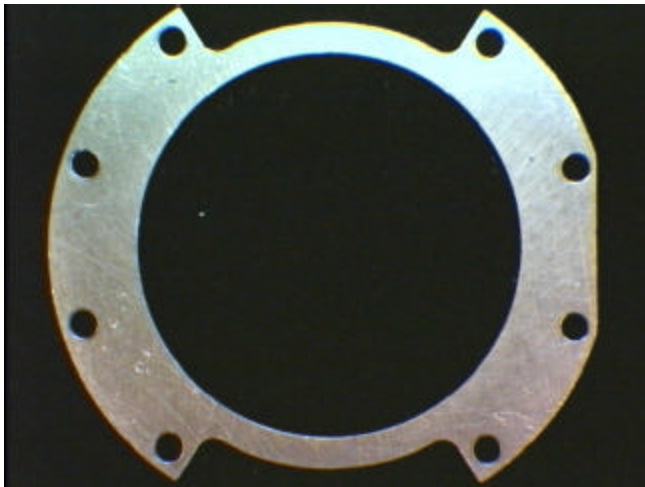

Nonrub Plate at 1500 Hours
Purified Fluid

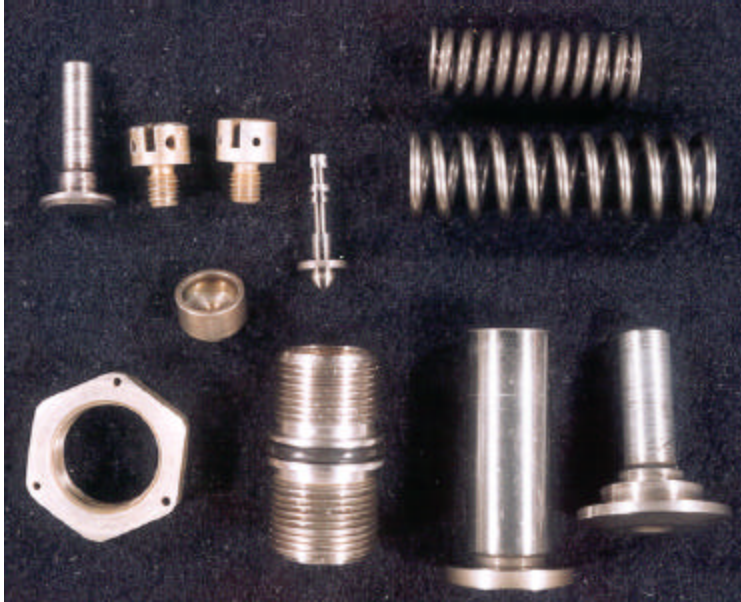

Miscellaneous Parts at Pretest
Fresh Fluid

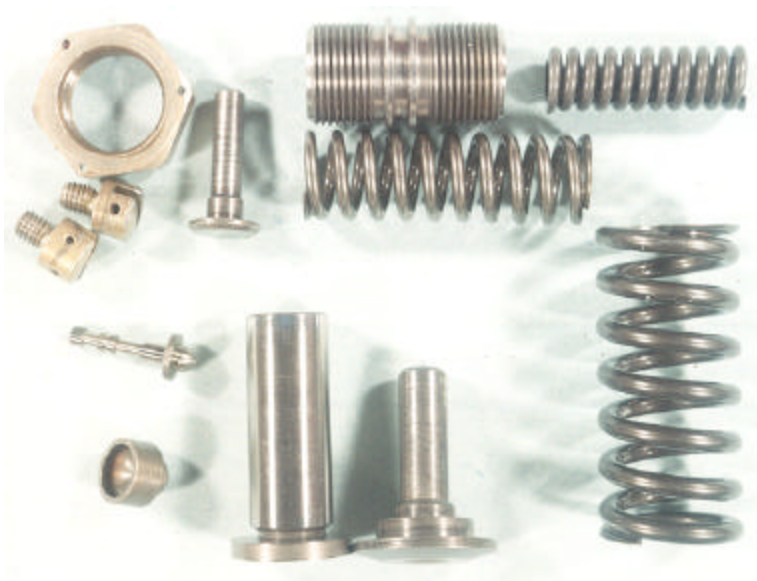

Miscellaneous Parts at 1515 Hours
Fresh Fluid



Miscellaneous Parts at Pretest
Purified Fluid



Miscellaneous Parts at 1500 Hours
Purified Fluid



Shaft Seal at Pretest
Fresh Fluid



Shaft Seal at 1515 Hours
Fresh Fluid



Shaft Seal at Pretest
Purified Fluid



Shaft Seal at 1500 Hours
Purified Fluid