

ERDC/EL TR-04-11

Environmental Laboratory

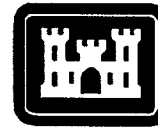

**US Army Corps
of Engineers®**
Engineer Research and
Development Center

Evaluation of Thorium-232 Distribution at Kirtland Air Force Base, Defense Nuclear Weapons School, Training Site 4

Steven L. Larson, John H. Ballard, Anthony J. Bednar,
Melissa G. Shettlemore, John C. Morgan, Morris P. Fields,
Christos Christodoulatos, and Rebecca Manis

July 2004

20040910 070

Evaluation of Thorium-232 Distribution at Kirtland Air Force Base, Defense Nuclear Weapons School, Training Site 4

Steven L. Larson, John H. Ballard, Anthony J. Bednar, Melissa G. Shettlemore, John C. Morgan,
Morris P. Fields

*Environmental Laboratory
U.S. Army Engineer Research and Development Center
3909 Halls Ferry Road
Vicksburg, MS 39180-6199*

Christos Christodoulatos, Rebecca Manis

*Center for Environmental Engineering
Stevens Institute of Technology
Castle Point on Hudson
Hoboken, NJ 07030*

Final report

Approved for public release; distribution is unlimited

Prepared for Stevens Institute of Technology
 Hoboken, NJ 07030
 and U.S. Army Picatinny Arsenal, NJ 07806

ABSTRACT: Ranges used at Kirtland Air Force Base, Albuquerque, NM, to train personnel in the identification of areas containing radioactive contamination provide an excellent test case for environmentally responsible training. These training sites have restricted access, and operations are conducted in compliance with a current Nuclear Regulatory Commission license. In order for the training to be realistic, the ranges have been amended with thorium oxide to simulate a plutonium spill. The environmental concern from the operation of these ranges is thorium migration through three mechanisms: wind, surface water, and vertical migration to groundwater. Field measurements have mapped thorium-232 distribution at the site, and led to laboratory experiments to determine mobility mechanisms. Column leaching experiments have shown that vertical migration is minimal, in agreement with field results. Soil extraction experiments indicate that thorium desorption from soil is colloidal. Additionally, electrokinetic experiments suggest thorium migration as a negative complex, possibly associated with organic matter. Soil stabilization techniques are being tested to determine an optimum method for reducing thorium mobility.

DISCLAIMER: The contents of this report are not to be used for advertising, publication, or promotional purposes. Citation of trade names does not constitute an official endorsement or approval of the use of such commercial products. All product names and trademarks cited are the property of their respective owners. The findings of this report are not to be construed as an official Department of the Army position unless so designated by other authorized documents.

Contents

Preface	v
Summary	vi
1—Introduction	1
Background and Site History	1
Contaminants of Interest	2
Purpose and Scope	3
Objectives	3
2—Methods	6
Safety Plan Development and Training	6
Development of Survey Technology	6
3—Surface Characterization	9
Surface Survey	9
Surface Data Analysis	9
4—Subsurface Characterization	15
Soil Sampling Procedure	15
Borehole Closure	16
ERDC Onsite Radiological Laboratory Description	16
Onsite Laboratory Evaluation Procedure	18
Subsurface Data Results	20
Air Monitoring Results	20
5—Sample Collection for Future Work	22
Soil Collection	22
Water and Sediment Collection	22
Plant Collection	23
6—Conclusions	25
7—Recommendations	26
Appendix A: Health and Safety Program	A1
Appendix B: Subsurface Characterization Results	B1
Appendix C: Isco Sampling Program	C1

SF 298

List of Figures

Figure 1.	Location of TS4 at Kirtland AFB.....	2
Figure 2.	Thorium-232 decay series	4
Figure 3.	Trailer-mounted multisensor array	7
Figure 4.	EDRC-developed mobile multisensor radiological data acquisition system architecture	7
Figure 5.	Mobile data acquisition system configurations	9
Figure 6.	Gamma activity calibration	10
Figure 7.	NaI gamma detector spectrum of 50-pCi/g calibration disk	11
Figure 8.	Color contour map of measured gamma and thorium activity at TS4	12
Figure 9.	GPS elevation map of TS4	13
Figure 10.	Arroyo originating in the western portion of TS4	14
Figure 11.	Soil boring locations at TS4	16
Figure 12.	EarthProbe™ hydraulic soil sampling device	17
Figure 13.	EarthProbe™ soil sampler	17
Figure 14.	Onsite gamma evaluation/counting stations.....	18
Figure 15.	Gamma evaluation/counting station architecture	19
Figure 16.	Thorium distribution in three dimensions	21
Figure 17.	Isco portable water and sediment sampler	23
Figure 18.	Plant sample collection and labeling	24

Preface

This report describes work performed by the U.S. Army Engineer Research and Development Center (ERDC), Vicksburg, Mississippi. This study was sponsored by the Stevens Institute of Technology (SIT), Hoboken, NJ, and the U.S. Army Picatinny Arsenal, New Jersey, under the Department of Defense U.S. Army TACOM/ARDEC Task #2 Project, Range Management and Remediation Technology Assessment Development and Demonstration (Contract No. DAAE30-00-D-1011, DO#0002).

This study was conducted and the report was prepared by Dr. Steven L. Larson, Mr. John H. Ballard, Dr. Anthony J. Bednar, Dr. Melissa G. Shettlemore, Mr. John C. Morgan, and Mr. Morris P. Fields, Environmental Laboratory (EL), ERDC; Dr. Christos Christodoulatos and Ms. Rebecca Manis, Center for Environmental Engineering, SIT. Dr. Charles A. Sparrow and Mr. Terry Coggins, Mississippi State University, Starkville, provided important advisement on radiation safety. Messrs. Charles Hahn, Thomas Berry, and Karl Konecny, EL, ERDC, and Messrs. Glen Childers and David Fluharty, Human Factors Applications, Inc., Waldorf, MD, provided field assistance.

The study was conducted under the direct supervision of Dr. George Korfiatis, SIT, and under the general supervision of Mr. Daniel E. Averett, Chief, Environmental Engineering Branch (EEB), EL, Mr. Michael Channell, Acting Chief, EEB, and Dr. Elizabeth C. Fleming, Acting Director, EL.

COL James R. Rowan, EN, was Commander and Executive Director of ERDC. Dr. James R. Houston was Director.

Summary

This report describes Phase I, Task 1, activities listed in the Work Plan for the TACOM/ARDEC Task #2 Project, Assessment of Potential for Off-site and Vertical Migration and Soil Stabilization Technology for the Containment of Thorium at a Training Site at Kirtland Air Force Base. Task 1 activities included site characterization, soil sampling, runoff water and sediment collection, and plant collection.

Soil containing thorium oxide, a low-level radioactive substance, was applied for approximately 30 years beginning in the early 1960's to eight training sites at Kirtland Air Force Base, Albuquerque, NM. These training sites have restricted access, and operations are conducted in compliance with a current Nuclear Regulatory Commission license. Thorium oxide in the amount of 3,482.9 kg was applied to the surface and incorporated into the soil of these training sites to simulate a plutonium release from a nuclear weapons accident. Despite the discontinuation of thorium applications in 1990, the substance is still present at these sites and has the potential to migrate offsite via wind and water transport, as well as vertically to groundwater.

Of the eight training sites, four are currently undergoing remediation involving excavation and removal of the contaminant. Training site 4 is the subject of study for the current report, and a description of the site is contained herein. Off-site Kirtland soils were evaluated for background radiation and were found to exhibit 2 pCi/g (± 2 pCi/g) background level of thorium. Hence, the term background will refer to ≤ 4 pCi/g thorium activity. From the initial field studies, it appears that thorium-contaminated soil is slowly migrating in the southwest and west directions to produce levels up to three to five times background in surface soils. Vertical migration is limited to the top 1 m of soil at about five times background in the most contaminated areas where application was heaviest.

The field studies used a new portable instrument, attached to an all-terrain vehicle (ATV), consisting of four sodium iodide detectors suspended from a trailer pulled by the ATV. The entire assembly also contained a global positioning system (GPS) in order to correlate measured soil activity to location (latitude, longitude, and elevation). This instrument arrangement was used to characterize the surface distribution of thorium.

Depth soil profiles were obtained with a hydraulically operated EarthProbe™ soil sampling system that pushed a steel-tipped 61-cm (2-ft) sampling tube into the soil to obtain samples from specified depths in approximately 61-cm (2-ft) increments. The results of multiple samples showed that elevated (greater than three times background) thorium levels were seen at a maximum of 0.8 m, with most samples being less than three times background at greater depths.

1 Introduction

Background and Site History

Kirtland Air Force Base (Kirtland AFB), Albuquerque, NM, established eight radiation training sites (designated TS1 through TS8) in the early 1960's for the purpose of training military radiological response personnel in the detection of dispersed contamination resulting from incidents involving nuclear weapons, as well as alpha radiation monitoring and decontamination. These training sites have restricted access, and operations are conducted in compliance with a current Nuclear Regulatory Commission license. Training sites were established by spreading, mixing, and raking imported Brazilian soil containing thorium oxide into the topsoil to simulate plutonium contamination resulting from a nuclear weapons accident. Thorium was chosen because it is a low-level radioactive substance. In 1972, the Defense Nuclear Weapons School (DNWS) was established in conjunction with the training activities and has continued to operate the training sites. In 1990, the Field Command Defense Special Weapons Agency and DNWS were ordered to cease thorium oxide application at the training sites. A total of 3482.9 kg of thorium oxide was applied to the eight sites (a total area of 33.56 ha (82.94 acres)) over the approximately 30-year period. Four of the sites, TS5 through TS8, are currently under remedial action involving excavation and offsite disposal.¹ Sites TS1 through TS4 are still active and are used several times a year for training of Department of Energy, Department of Defense, Federal Emergency Management Agency, and other Federal and State agency personnel in emergency operations at nuclear accident sites. Of the active sites, TS4 is available for investigation and pilot studies. During the field investigation reported herein, radiation levels outside the TS4 perimeter fence were not found to pose a human health risk.

TS4 is located northwest of the Kirtland AFB Tijeras Arroyo Golf Course and has an area of 4.2 ha (10.3 acres) over which 657.6 kg of thorium sludge was spread from 1961 to 1990² (Figure 1). Thorium distribution and activity at TS4 is highly heterogeneous. Radiological studies on soil cores from TS4 indicate that thorium has been transported vertically into the top 61 cm (2 ft) in the hot spot areas. A study conducted in 1985 found surface thorium activity ranging from 2.1 pCi/g in the less contaminated areas to 151.3 pCi/g at areas where larger masses of thorium sludge were applied. No historic information is available on vertical thorium migration for depths greater than 61 cm. Periodic radiation

¹ R. A. August, G. W. Phillips, M. Harper, M. Nelson, and S. Gann. (1999). "Mixed waste characterization in soil," *Nucl. Instru. and Meth. in Phys. Res.* 422, 767-772.

² Kirtland Air Force Base. (1994). "Characterization plan for the Interservice Nuclear Weapons School sites and the radium dump/slag piles Site at Kirtland Air Force Base," Albuquerque, NM.

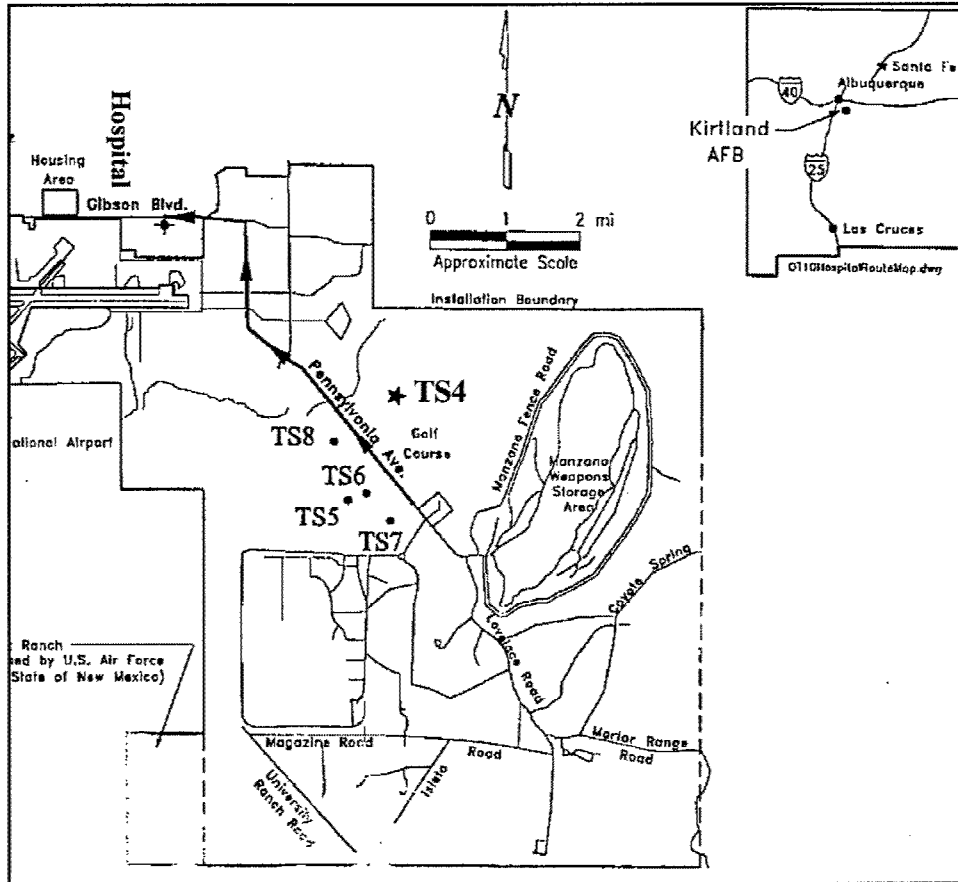

Figure 1. Location of TS4 at Kirtland AFB

monitoring of the site has revealed migration of thorium outside the fenced area¹ and at depths of up to 38.1 cm. Concentrations of thorium 4.5 times higher than background were detected in soil at the western boundary of the site.¹ Previous air sampling at the site indicated thorium concentration less than background.²

Contaminants of Interest

The primary contaminant of interest is thorium (Th) in the form of thorium oxide (ThO₂). Thorium is a lustrous silver-white radioactive metal and is a member of the actinide series (group IIIb of the periodic table). It is widely distributed in small amounts in the earth's crust and is about three times more abundant than uranium. The chief commercial source of thorium is monazite (phosphate mineral found in the form of sand) obtained from India and Brazil. Thorium is usually contaminated with small amounts of oxide that cause it to tarnish rapidly, and the oxide formed has the highest melting point of all oxides. ThO₂ is the most important thorium compound and is the major incandescent

¹ S. E. Rademacher. (1993). "Environmental surveillance on the 3416 Technical Training Squadron inactive training sites: 01 December 1988 - 03 January 1990."

² Kirtland Air Force Base. (1997). Kirtland Air Force Base, field investigation report for the Defense Nuclear Weapons School sites," Albuquerque, NM.

component in lantern mantles. Thorium is also used in magnesium alloys and in tungsten filaments for light bulbs.

There are 26 known radioactive isotopes of thorium. The most stable is thorium-232 (half-life of 1.41×10^{10} years); it is the major component of naturally occurring thorium and has an atomic weight of 232.038 atomic mass units. Thorium-232 undergoes a natural disintegration and eventually is converted through a 10-step chain to lead-208, a stable isotope (Figure 2). Alpha and beta particles as well as gamma rays are emitted during this decay.

The hazards associated with thorium-232 include its radioactivity and the emission of radon-220 gas (also known as thoron). The derived airborne concentration (DAC) for thorium-232 is 5×10^{-13} $\mu\text{Ci/ml}$. The DAC refers to the concentration of radionuclide in air that would result in an intake of one "annual limit on intake" if breathed for 2,000 hr.

Purpose and Scope

The extent of thorium migration at TS4 has not been previously fully defined, and the mechanisms for offsite migration are unknown. Possible mechanisms include surface runoff and sedimentation, wind erosion and transport, and unsaturated zone migration. Although TS4 is an active site, it is rarely used for training; however, it may be utilized in the future to simulate urban environments that will require erection of various kinds of structures, paved roads, etc. It is therefore essential for the training operations to develop and implement a thorium-232 management plan for the site that will allow long-term use and minimize vertical and horizontal migration outside the site boundaries. A plausible management plan may include stabilization of the soil surface to prevent further transport by water infiltration base transport, air-borne mobility, and runoff.

Objectives

This project focused on thorium-232 surface and subsurface distribution at TS4 and potential routes of migration. Soil stabilization technologies will be investigated for their potential to reduce vertical and horizontal migration of the thorium offsite. This scope of work was developed by Stevens Institute of Technology (SIT), Hoboken, NJ, in collaboration with the U.S. Army Engineer Research and Development Center (ERDC), Environmental Laboratory (EL), Vicksburg, MS, and Kirtland AFB personnel. The primary objectives of Phase I work were to conduct a characterization of TS4 soils to determine surface and subsurface levels of thorium-232 activity and to determine potential routes of thorium migration. This report documents the methodology used to perform a radiological characterization of surface and subsurface soils for thorium-232 and the results of surface and subsurface data collection activities. In addition, the collection of soil, sediment, water, and plant samples from the site is described.

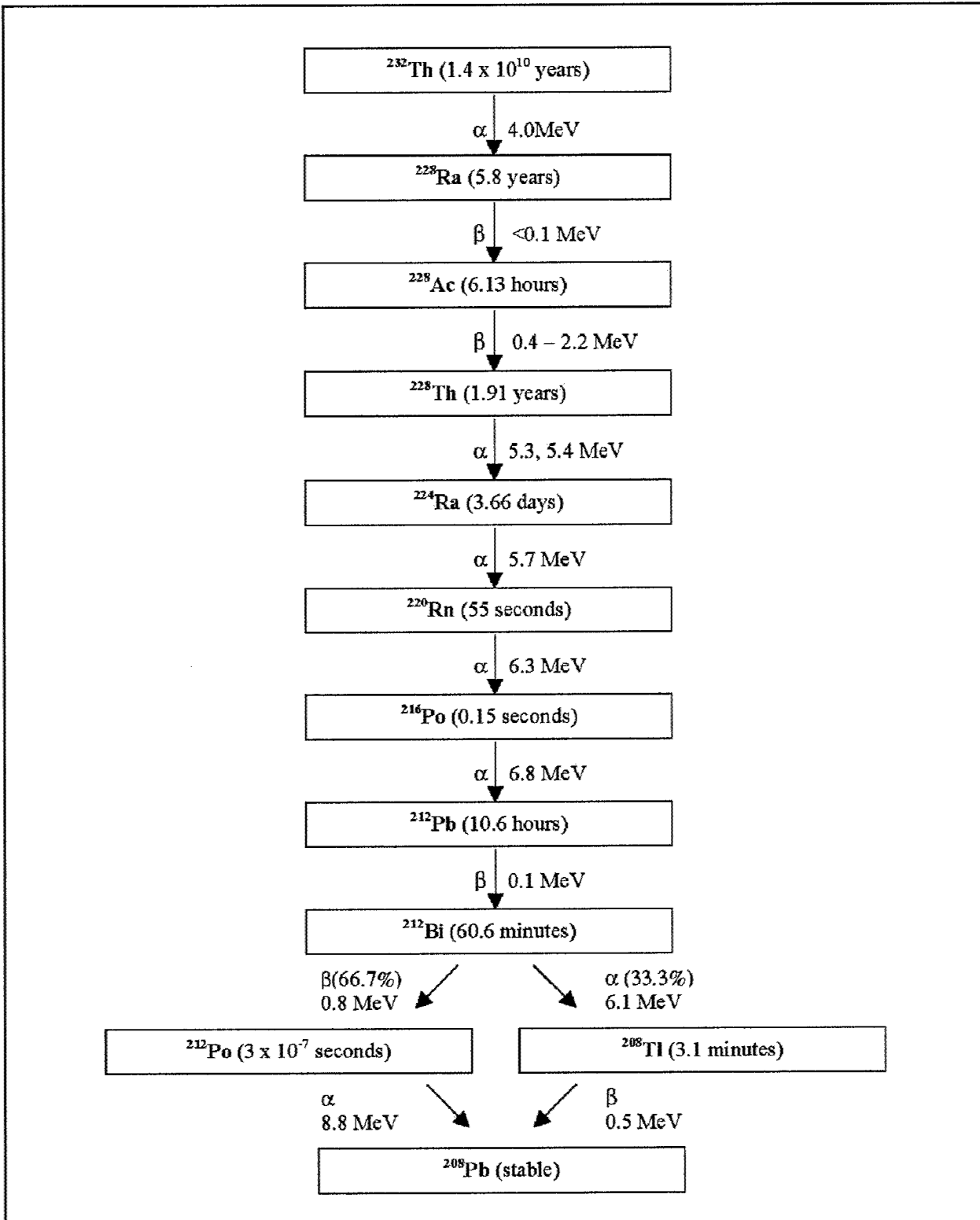

Figure 2. Thorium-232 decay series. Each elemental step is shown with the half-life following in parentheses. The type of decay (alpha (α) or beta (β)) is also shown along with the corresponding energy

Specific objectives were to complete the following:

- a.* Develop appropriate radiation safety plans and training procedures for conducting field tests at TS4.
- b.* Develop a mobile gamma survey system for rapid assessment of surface soil for thorium-232.
- c.* Quantify surface radiological activity levels and the extent of lateral migration of thorium-232.
- d.* Establish an onsite radiological laboratory for evaluation of TS4 subsurface soil samples.
- e.* Obtain core soil samples to characterize the subsurface (vertical) migration of thorium-232.
- f.* Collect TS4 vegetation samples for later offsite radiological content evaluation.
- g.* Collect soil, sediment, and water samples adjacent to TS4 for later study.

2 Methods

Safety Plan Development and Training

The characterization of the thorium-contaminated soil at TS4 was a cooperative effort involving personnel from SIT, ERDC, Alion Science and Technology, Chicago, IL, and Mississippi State University (MSU), Starkville, MS. Prior to field activities, a Health and Safety Program was developed including a Health and Safety Plan (HSP), Work Plan, and Radiation Safety Plan (Appendix A). Special attention was given to the radiological and heat hazards present at TS4. In addition, all team members received 8 hr of U.S. Army Corps of Engineers (USACE) training in radiation physics, biological effects, use of instrumentation, and safety practices for working with ionizing radiation.

Development of Survey Technology

The radiological site characterization of TS4 was performed using a mobile multisensor system developed by ERDC. The system had the capability to detect and speciate (identify) surface and near surface gamma-emitting radionuclides. The system coupled surface gamma activity with location and elevation data from a Global Positioning System (GPS) in real time. GPS system accuracy was ± 2 to 3 cm horizontal and ± 3 to 5 cm vertical.

The data acquisition system was configured for all-terrain vehicle (ATV) deployment. In the original configuration, an ATV was used to pull a cart onto which the data acquisition system was mounted. A concept drawing of the data acquisition system is shown in Figure 3. The gamma sensor array consisted of four 7.6-cm by 7.6-cm (3-in. by 3-in.) BicronTM sodium iodide gamma detector/photomultiplier tube assemblies that were suspended behind the cart, 10 cm above and parallel to the ground. Each detector used in the system operated independently with separate computer and nuclear instrument data acquisition and processing modules. A block diagram of the multisensor array architecture is provided in Figure 4. Data from each detector were collected via a multichannel buffer (MCB) by the data acquisition central processing unit (CPU). The CPU also kept track of the corresponding location and temperature readings. In this configuration the data were collected, processed, and stored in parallel for later postprocessing and analysis.

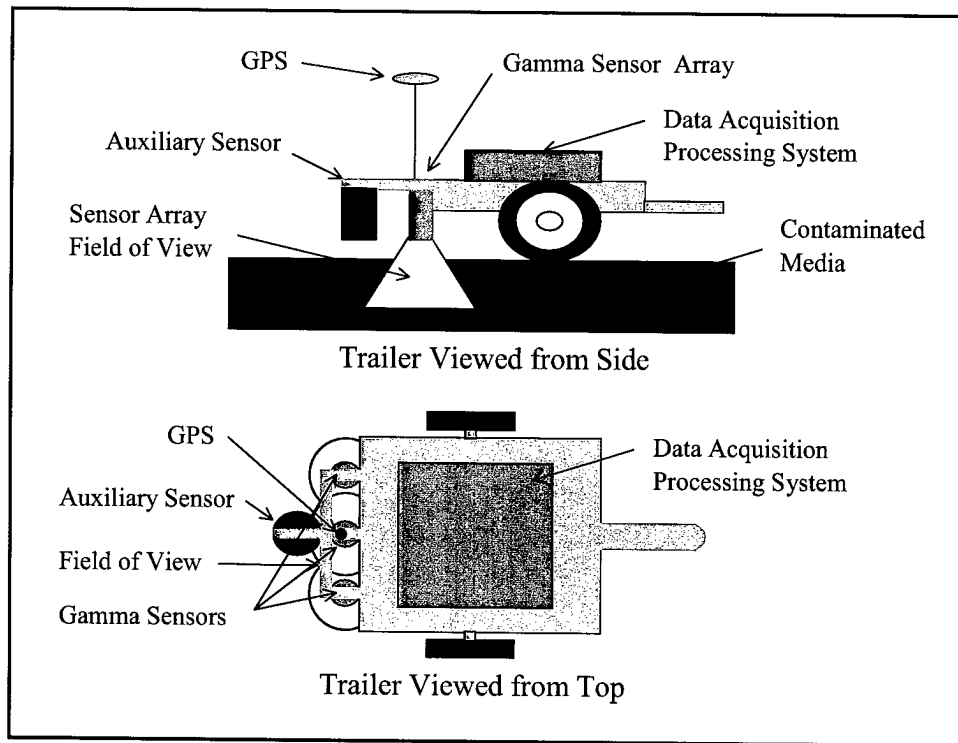

Figure 3. Trailer-mounted multisensor array. Side and top views of cart configuration

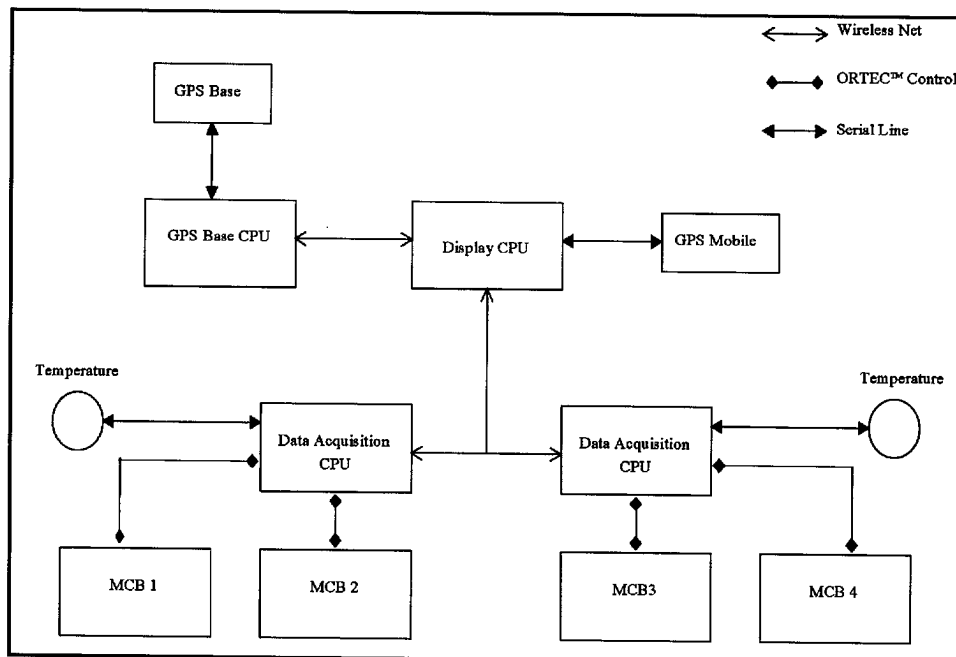

Figure 4. EDRC-developed mobile multisensor radiological data acquisition system architecture. Data from each detector were routed through an ORTEC™ MCB to the data acquisition CPU. The spectral gamma data were collocated with GPS and temperature data

The configuration was later improved by using an ATV as the platform for the data acquisition system. The four sodium iodide (NaI) detectors were suspended behind the ATV 10 cm above and parallel to the ground. This configuration performed much better in the rough desert terrain. As in the previous configuration, each detector used in the system was operated independently with separate computer and nuclear instrument data acquisition and processing modules. However, the data were collected, processed, and summed in real-time and averaged during postprocessing. The data were then stored for later analysis.

3 Surface Characterization

Surface Survey

Two trips to field site TS4 were needed to complete site characterization. The first was in October 2001 and the second was in December 2001. The ERDC spectral gamma data acquisition system was driven across the surface of TS4 at approximately 3.2 km/hr (2 mph). A GPS antenna was positioned at the center of the four-detector array to document changes in topography elevation and the position of the gamma detectors as real-time gamma activity data were collected. In this manner the gamma activity was collected and documented with GPS elevation and coordinate data. The ATV operator used surface landmarks and tire impressions from previous passes to guide the gamma detector array over the majority of the site. Time constraints and GPS dropouts prevented 100 percent site coverage. The original and modified mobile data acquisition system configurations are shown in Figure 5.

Surface Data Analysis

The surface gamma activity data, collocated with GPS data, were collected with the four-detector array, summed, and averaged. The processed data were

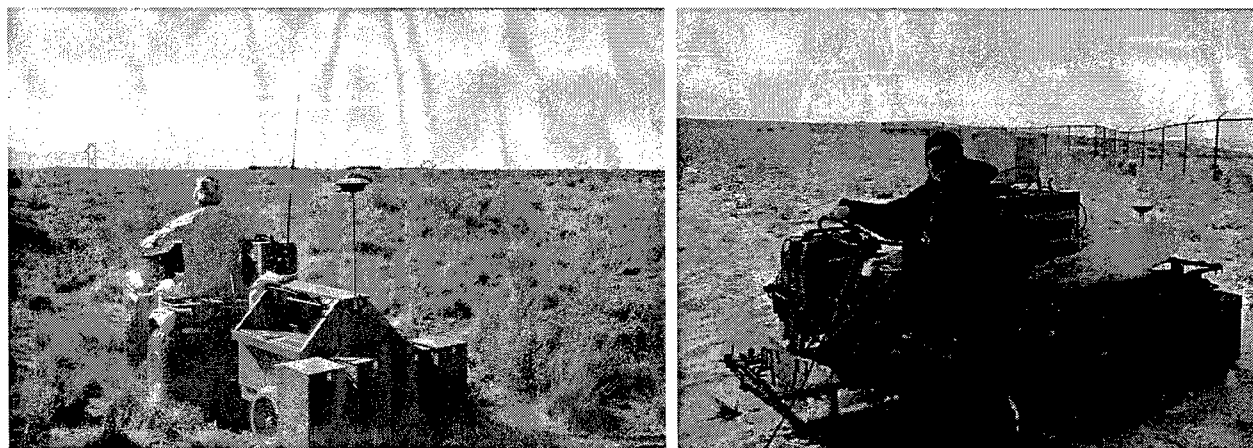

Figure 5. Mobile data acquisition system configurations. The original configuration (left) was an ATV which pulled the cart-mounted data acquisition system. The modified configuration (right) was an Army Mule ATV with the detectors directly mounted to the rear of the ATV. Both configurations used four NaI gamma detectors and a GPS

used to develop an activity level for a 1.2-m (4-ft) footprint beneath the detector array. Next, calibrated laboratory gamma activity was acquired at the MSU Calibration Facility using the unique MSU-designed thorium calibration disk. The MSU calibration disk, measuring approximately 81 cm (32 in.) in diameter by 5.1 cm (2 in.) in thickness, was fabricated in concrete with 50-pCi/g thorium oxide (thorium with thorium progeny in equilibrium). The NaI gamma detectors were positioned approximately 10 cm above the center of the 50-pCi/g thorium calibration disk (Figure 6). A gamma ray spectrum of thorium and thorium progeny in equilibrium collected using the configuration of Figure 6 is presented in Figure 7. Since thorium is an alpha emitter, spectral gamma data were analyzed for the thorium progeny gamma activity. Since the Kirtland AFB thorium-enriched training sites were established 40 years ago with material containing thorium in equilibrium with thorium progeny (radioactive daughter products), the presence of a second thorium decay product, actinium-228, was used to measure thorium-232 activity. Actinium-228 in equilibrium with thorium-232 produces prominent photon (gamma) emissions at 338, 911, and 969 keV. The actinium-228 911- and 969-keV gamma emissions were selected for evaluation and quantification for determining the activity level for thorium-232.

Surface and near-surface gamma activities were measured outside the boundary of TS4 to determine the average gamma activity background for Kirtland AFB soils in the vicinity of TS4. The results of the calibration experiments were correlated with surface gamma activity measured at the Kirtland AFB training site. Measurements determined that the average

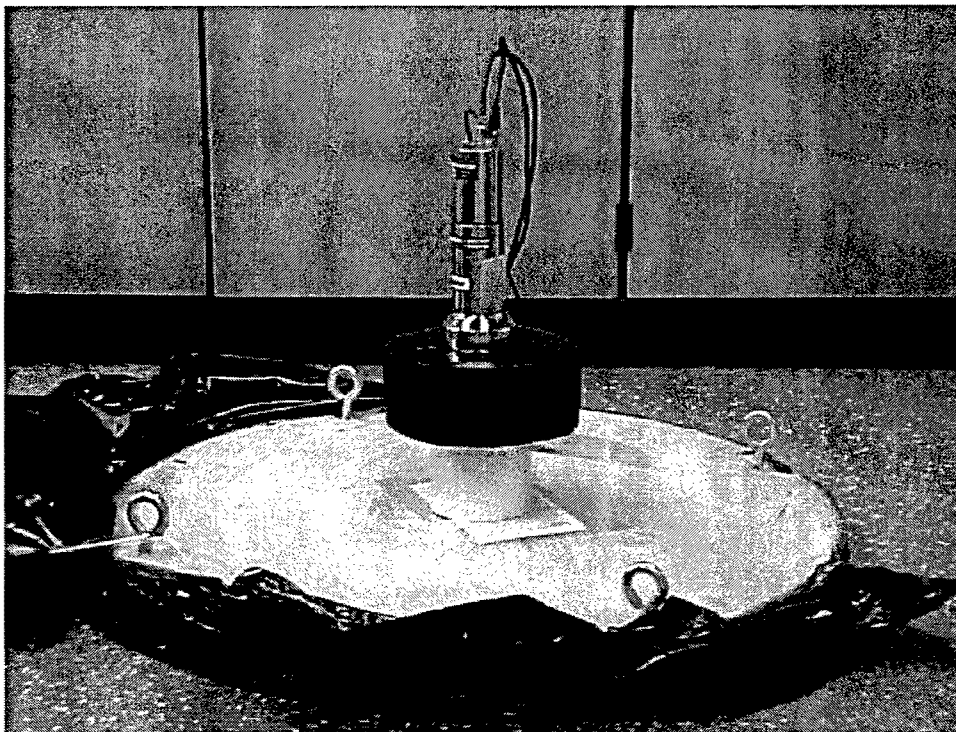

Figure 6. Gamma activity calibration. A NaI gamma detector surrounded by lead ring and positioned 10 cm above the 50-pCi/g thorium calibration disk. The disk was 81 cm (32 in.) in diameter and contained thorium and thorium progeny in equilibrium



Figure 7. NaI gamma detector spectrum of 50-pCi/g calibration disk. The arrows denote the gamma energy lines of actinium-228 used to determine levels of thorium-232 activity

background gamma activity was approximately $2 \text{ pCi/g} \pm 2 \text{ pCi/g}$ and was consistent with onsite laboratory verification sample results.

The processed gamma activity data for TS4 was integrated with GPS coordinate data and displayed as a color contour map in Figure 8. Due to the rough terrain at TS4, exact values of thorium activity cannot be ascertained for all locations since the gamma detector array was not always positioned parallel to the surface and could not always be maintained at the calibration height of 10 cm above the terrain surface. However, the relative values shown in Figure 8 are representations of the thorium activity and can be used to identify probable pathways of thorium migration.

The contour map of TS4 presented in Figure 8 corresponds to surface gamma activity and also to levels of thorium activity. Background levels of gamma activity are represented in blue and range from 0 to 4 pCi/g. The uncolored, oval-shaped region in the middle of the radiation hot zone is the location of a helicopter body. Regions of low gamma activity (low thorium activity) range from 4 to <16 pCi/g and are shown in green. Moderate gamma activity (moderate thorium activity) ranges from 16 to <57 pCi/g and is shown in yellow. Regions of high gamma activity (high thorium activity) are shown in red and are located

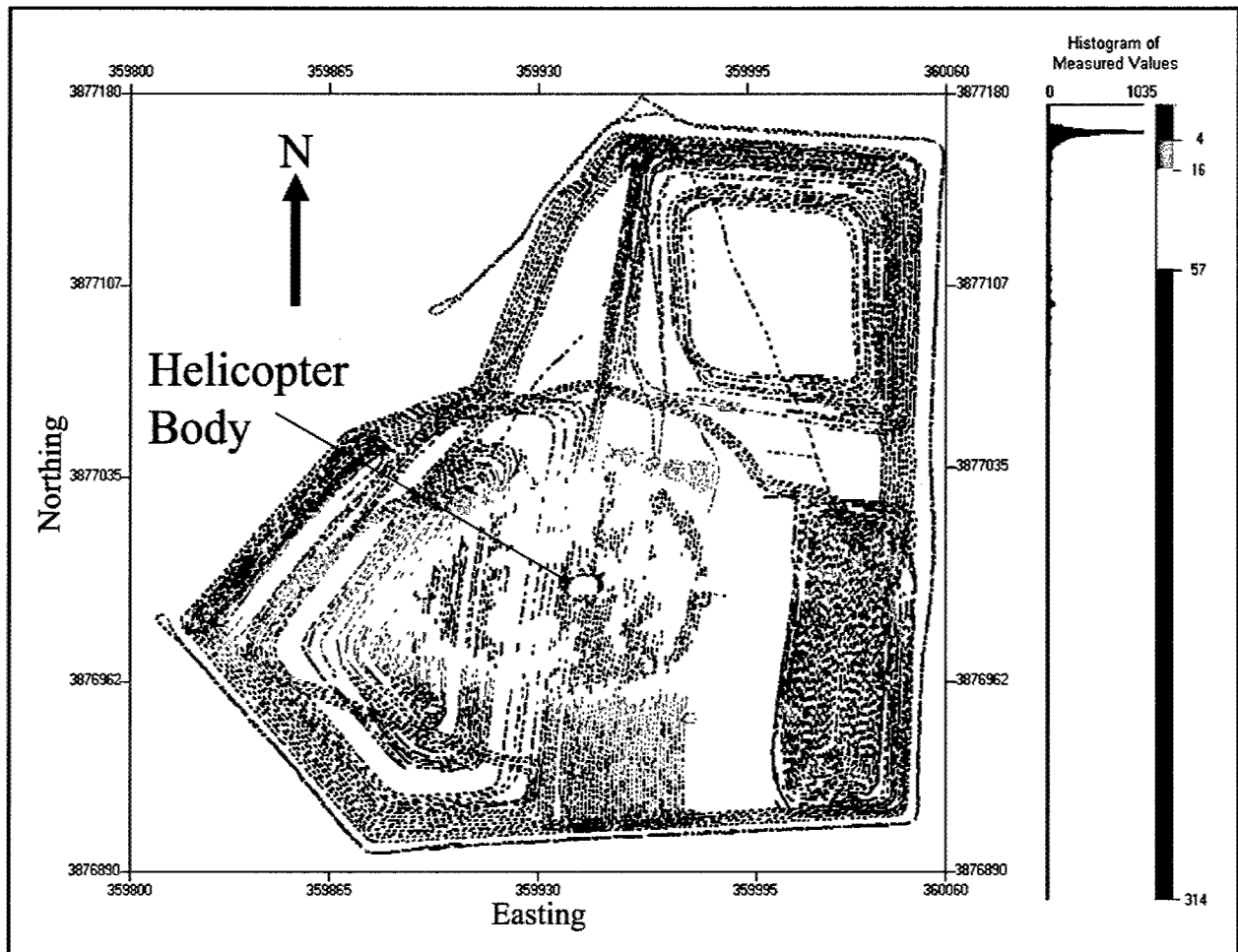

Figure 8. Color contour map of measured gamma and thorium activity at TS4

in the vicinity of the helicopter body. The helicopter body is represented in Figure 8 as a white oval inside the red region since no data could be collected beneath the helicopter. The lower limit for red was selected as 57 pCi/g since the U.S. Department of Transportation does not allow unregulated shipment of thorium-contaminated material that measures 57 pCi/g or greater.

Gamma activity data were collected in the rectangular region in white on the east side of the helicopter body in Figure 8. However, due to a GPS malfunction, the gamma activity data could not be accurately positioned for this region. Hence, no data are shown for this region. The gamma data processed for this region had low and moderate levels of gamma activity (thorium contamination) and would have extended the regions of yellow and green activity levels eastward in Figure 8.

The GPS elevation data shown in Figure 9 indicate that site elevations measured from the northwest to the southwest ends of the site drop approximately 1.9 m. GPS data also indicate that elevation from the helicopter to the southwest corner drops approximately 0.5 m. Due to decreasing elevation toward the southwest quadrant of the site, it is likely that surface rainwater runoff could transport

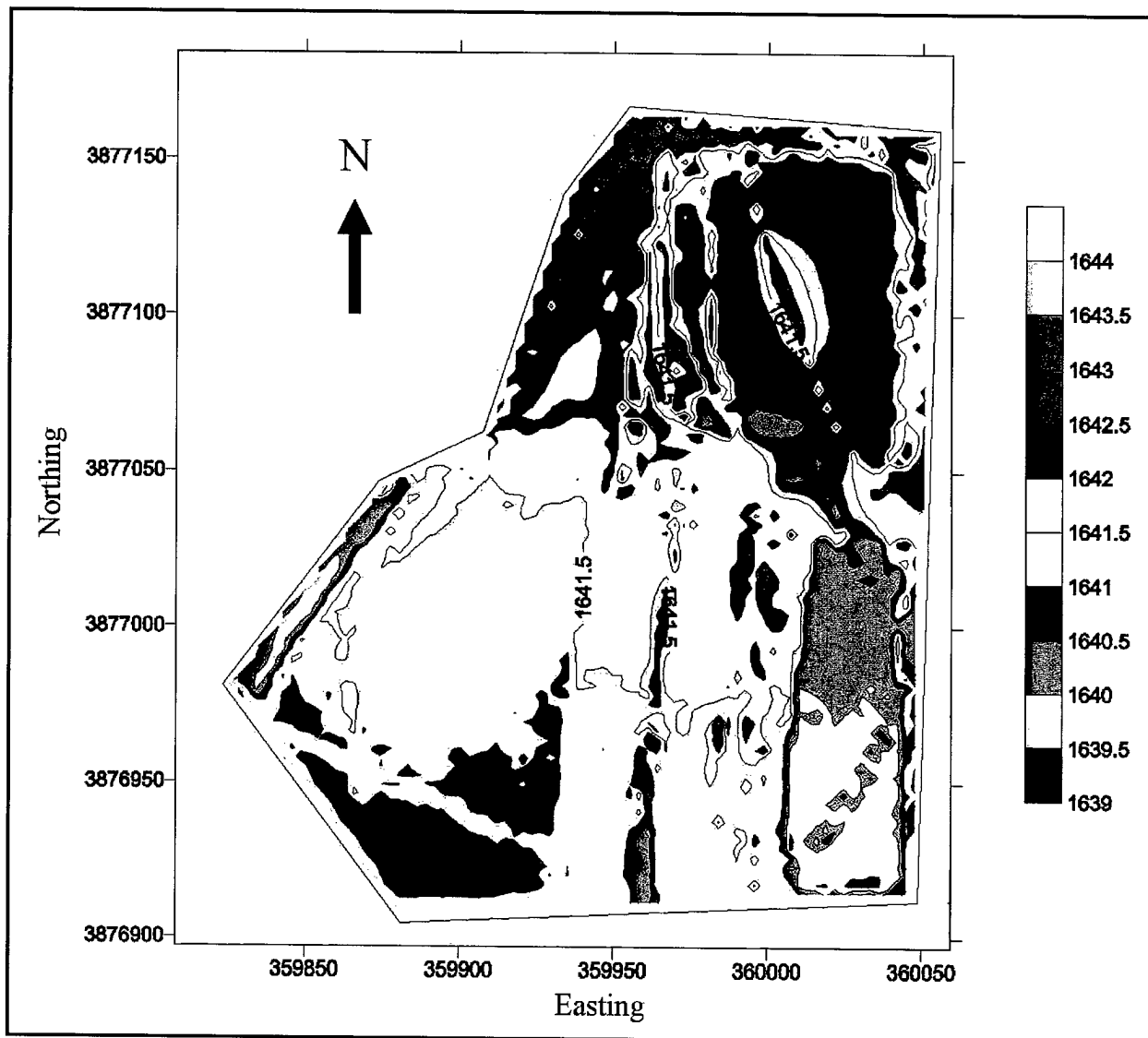

Figure 9. GPS elevation map of TS4

low levels of thorium-enriched soil toward the southwest quadrant of the site and possibly into soil adjacent to the southwest quadrant. Annual rainfall for Kirtland AFB is approximately 25 cm. The west side of the site is positioned parallel to several large arroyos, one of which originates with the southwest quadrant of the site (Figure 10).

Possible routes of thorium migration can be identified using Figures 8 and 9. It appears that low levels of thorium contamination (green region in Figure 8) may be migrating toward the southwest and south site boundaries away from regions of higher concentrations that surround the helicopter body. Specifically, there are contours that indicate migration routes toward the southwest, south, and east. The eastern migration of thorium-contaminated soil is occurring along egress routes from the helicopter body to the east perimeter gate. This migration may be due to vehicular traffic crossing over thorium-contaminated soil in the vicinity of the helicopter and driving toward the eastern gate.



Figure 10. Arroyo originating in the southwest quadrant of TS4

4 Subsurface Characterization

Soil Sampling Procedure

In order to determine the extent of vertical migration of thorium-232, soil borings were collected at 33 locations within and adjacent to TS4. The GPS locations of the samples are shown in Figure 11. An EarthProbe™ soil-sampling device (Figure 12) was used to hydraulically hammer (push) sample chambers into the soil in 61-cm (2-ft) segments. An EarthProbe™ 61-cm rod-sampling segment consisted of outer steel housing, tip, and inner plastic sample chamber (Figure 13). During soil collection activities, the EarthProbe™ hydraulically hammered (pushed) 61-cm steel rods with retractable steel tips into the ground. During soil collection, the steel tip was pushed by soil into and through the plastic inner tube. Due to space occupied by the steel tip and other internal tip release assembly parts, a maximum of 54.6 cm (21.5 in.) of soil was collected per 61-cm push. On pushes greater than 61 cm, the tip was locked in place until the desired sampling depth was reached. Once sampling depth was reached, an internal release mechanism was activated to allow subsequent pushing to force the tip and soil into the inner plastic sampling tube. In this manner, soil was sampled at each location to a depth of 3.05 m (10 ft). Some sampling segments provided less than 54.6 cm of soil. It is thought that soil compaction may have occurred in some cases and that soil insertion reached refusal in other cases. Soil not inserted into one 61-cm segment was not pushed into a subsequent tube since the conical steel sampler tip was locked in place during subsequent pushes and pushed soil aside as the conical-tipped probe was pushed to the next sampling depth.

Soil borings were collected to a depth of 3.05 m unless refusal to push occurred (often due to large rocks). Sample locations 1-15 were positioned outside the TS4 perimeter fence (Figure 11). Sample locations 16-33 were positioned within the thorium-enriched training site. Soil borings were collected in 55.2-cm (21.75-in.) plastic tubes, decontaminated of surface radiological contaminants, and stored for onsite radiological laboratory analysis for radionuclide speciation and levels of activity.

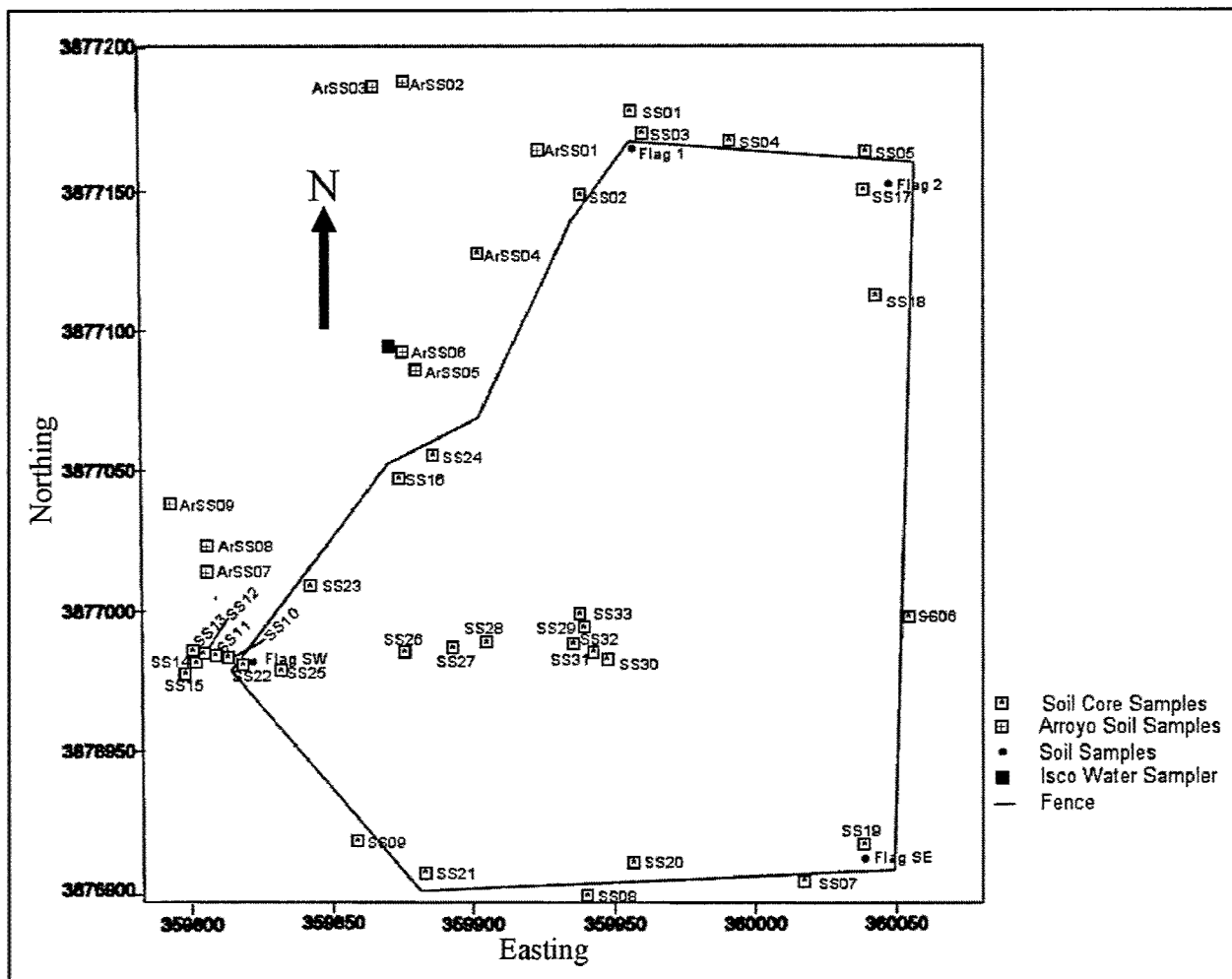

Figure 11. Soil boring locations at TS4

Borehole Closure

Borehole closure was conducted to prevent future cross-layer contamination by way of open boreholes. A grout mixture containing portland cement, water, and approximately 10 percent bentonite clay was prepared outside TS4 using an electrically powered drill-mixer. The grout mixture was carried in 0.02-m³ (5-gal) plastic buckets via vehicle and poured into each borehole. Settling often occurred as trapped air bubbled through the grout; thus, the grouting process was repeated two and sometimes three times to complete borehole closure.

ERDC Onsite Radiological Laboratory Description

The ERDC mobile radiological laboratory was used to evaluate the soil borings collected at TS4. The mobile laboratory consisted of five independently operated gamma evaluation/counting stations (Figure 14) and utilized the equipment used during the surface radiological site characterization phase of the

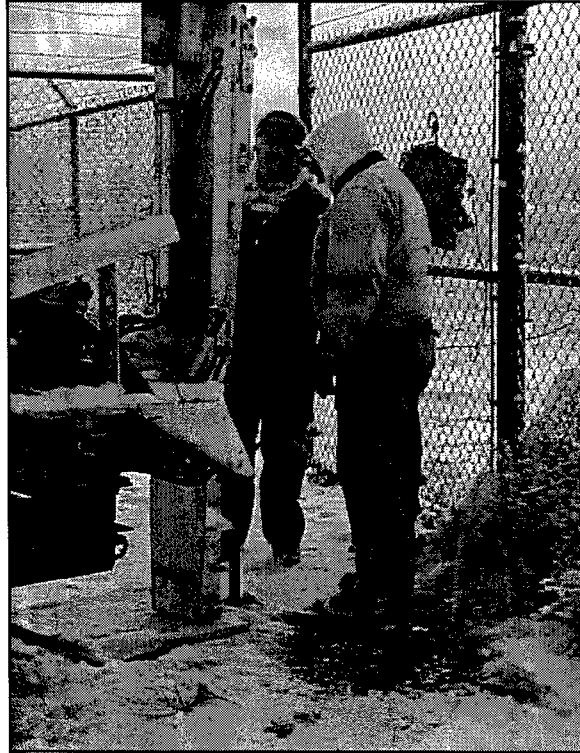

Figure 12. EarthProbe™ hydraulic soil sampling device

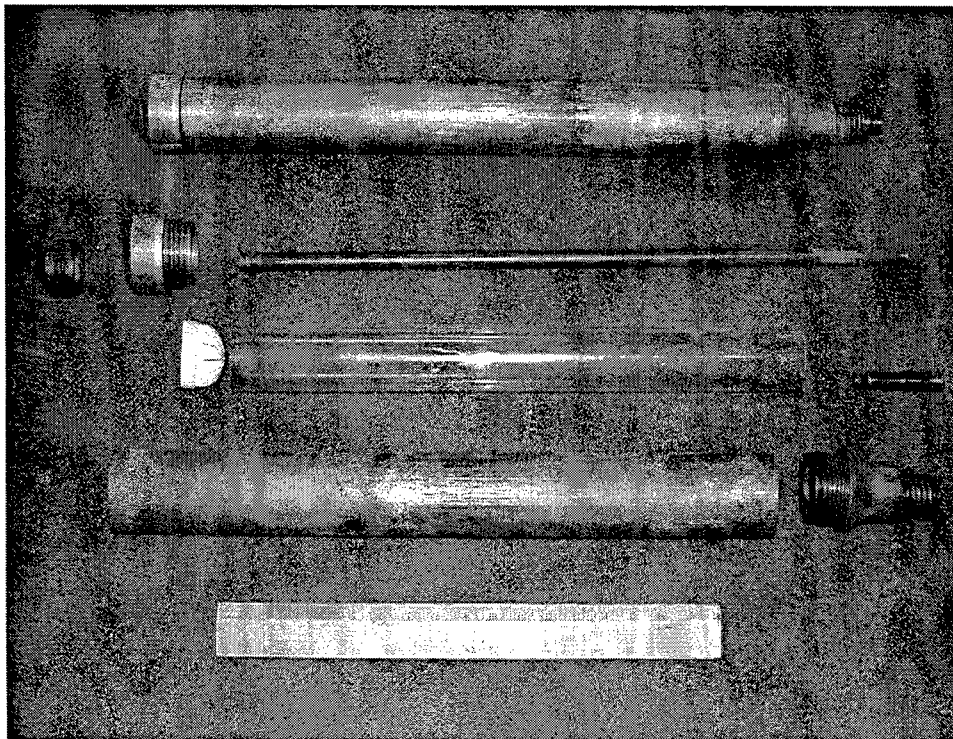

Figure 13. EarthProbe™ soil sampler. The sampler consists of a 61-cm (2-ft) outer steel housing, tip, and internal plastic sample chamber

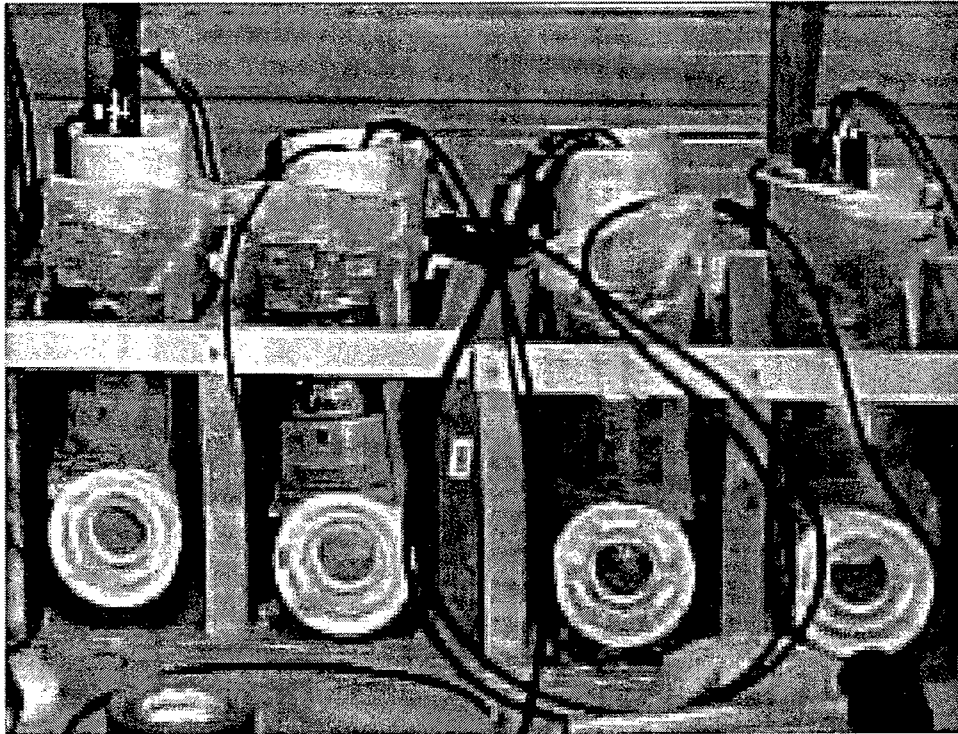

Figure 14. Onsite gamma evaluation/counting stations. The stations were fabricated with polyvinyl chloride (PVC) T-pipe surrounded by lead shielding

project. A block diagram of the onsite radiological laboratory is shown in Figure 15. The mobile laboratory was also used during calibration comparison studies at the MSU Calibration Facility. EPA standard method series for aqueous metal concentrations (including thorium) is 6000 (Inductively Coupled Plasma – Mass Spectrometry and Inductively Coupled Plasma – Atomic Emission Spectroscopy)¹ and was used for offsite analysis of soil and plant samples.

Onsite Laboratory Evaluation Procedure

The 54.6-cm (21.5-in.) plastic soil sampling tubes were removed from the EarthProbe™ 61-cm (2-ft) outer steel sampler housing and inspected for soil content. The soil content of each tube was measured and recorded, and 15.2-cm (6-in.) segments of tubing containing soil were marked on the outside of each tube corresponding to the appropriate vertical position the soil represented. For example, at each sampling location, tube one was marked for 0 to 15.2-cm (0 to 6-in.), 15.2- to 30.5-cm (6- to 12-in.), 30.5- to 45.7-cm (12- to 18-in.), and 39.4- to 54.6-cm (15.5- to 21.5-in.) segments. It should be noted that soil analyzed in the fourth position of each tube overlapped 6.4 cm (2.5 in.) of soil in the third tube segment. In this manner, the detector-to-soil geometry used throughout the

¹ U.S. Environmental Protection Agency. (1986). *Test Methods for Evaluating Solid Waste, Physical/Chemical Methods*, SW-846, Office of Solid Waste and Emergency Response, Washington, DC.

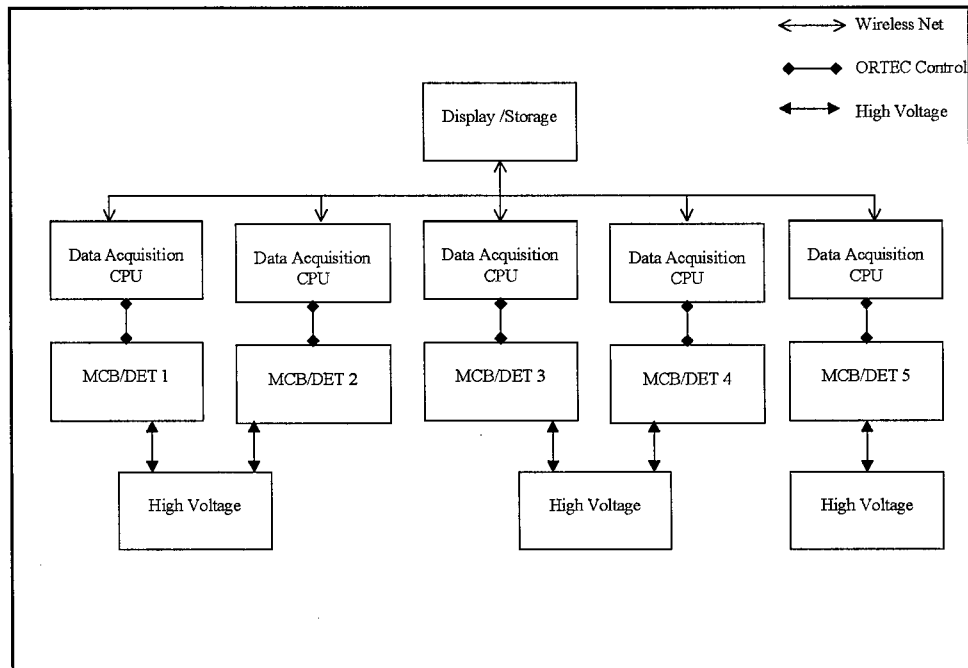

Figure 15. Gamma evaluation/counting station architecture (DET 1 = detector 1; DET 2 = detector 2; DET 3 = detector 3; DET 4 = detector 4; DET 5 = detector 5)

laboratory analysis was maintained (i.e., 15.2 cm (6 in.) of soil filled the field of views of the NaI gamma detector for each analysis). Next, tube two was marked corresponding to soil collected in 61- to 76.2-cm (24- to 30-in.), 76.2- to 91.4-cm (30- to 36-in.) segments, etc. This process was repeated for the five tubes collected at each sampling location. When soil tubes were not filled to capacity, the soil was divided into 15.2-cm (6-in.) segments using the soil available.

Five NaI gamma detector spectrometers with shielding (Figure 14) were assembled onsite using an inverted T-shaped PVC pipe surrounded by lead shielding material. Soil tubes were inserted through the horizontal portion of the inverted pipe in a manner that centered each 15.2-cm (6-in.) soil segment. The NaI gamma detector was positioned vertically in the inverted T with the detector field of view positioned above the sealed plastic soil tubes. For spectral gamma data acquisition events, the detector was positioned above the center of each 15.2-cm (6-in.) soil segment that was situated horizontally in the PVC pipe and interrogated for 30 min. The gamma energy spectrum was saved for later offsite postprocessing and analysis. The tube was moved horizontally beneath the gamma detector to center each 15.2-cm (6-in.) soil segment for subsequent soil sample interrogation. Since each tube had the capacity to hold four 15.2-cm (6-in.) segments of soil, the spectral gamma interrogation of each tube required a maximum of 2 hr to complete. Tubes with less soil required less spectral gamma interrogation time.

Subsurface Data Results

Postprocessing of spectral gamma data was conducted offsite after field and laboratory investigations were completed at Kirtland AFB. Spectral gamma data sets were analyzed for thorium progeny gamma activity. As with the surface characterization, the soil samples were analyzed quantitatively for actinium-228 gamma emissions during postprocessing activities by comparing spectral gamma results from the soil borings with spectral gamma results collected using the thorium-232 calibration disk at the MSU Calibration Facility.

Figure 16 shows the depth of thorium contamination at TS4. Thorium levels greater than 2 pCi/g were seen at a maximum depth of 84 cm (33 in.) below the surface and only for sampling locations near the helicopter. Subsurface thorium activity for each sampling location is presented in Appendix B, which provides a vertical profile of thorium activity for each sampling location to approximately a 3.05-m (10-ft) depth. It was noted during soil sampling activities that surface soil sometimes fell into the open hole between sampling events. The results annotated by asterisks in Appendix B indicate subsurface samples with elevated levels of thorium activity attributed to surface soil accumulating in the first segment of a subsequent 0.6-m (2-ft) sampling event. Lower levels of thorium activity in subsequent soil segments support this hypothesis. Activity levels that fell within the range of natural background were entered as 0 pCi/g. Based on comparative evaluations with MSU-developed thorium calibration sources, the results presented in Appendix B may exhibit a ± 2 -pCi/g variance.

Air Monitoring Results

A LudlumTM 333-2 Air Monitor and SKCTM Personal Air Monitors were used during the surface and subsurface characterization activities to monitor airborne radiation levels. Air filters were analyzed using the NaI counting stations. At no time during the characterization studies did airborne concentrations exceed the allowed DAC for thorium.

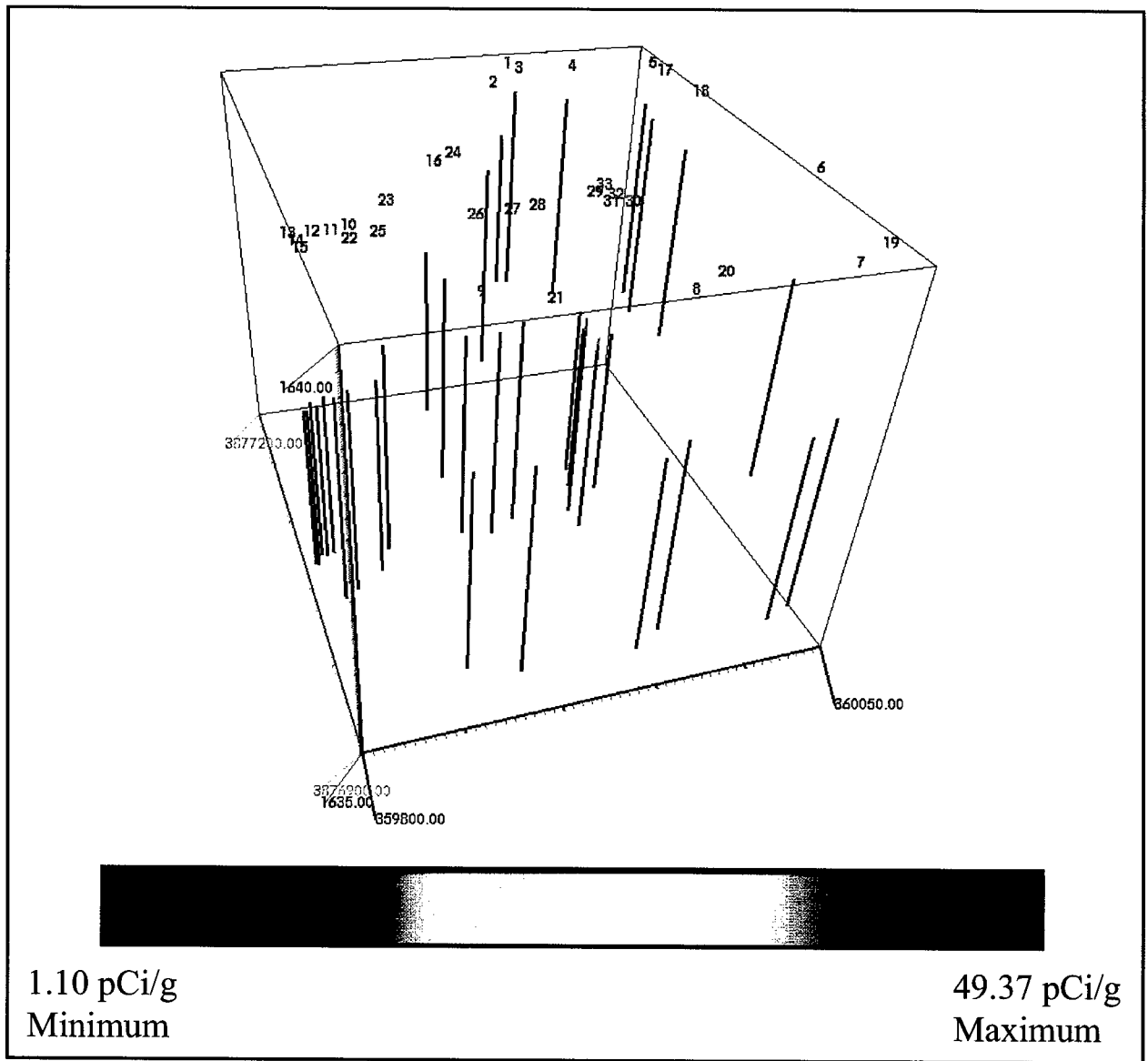

Figure 16. Thorium distribution in three dimensions. Elevated thorium activity levels were measured at only a few sampling sites near the helicopter at the center of the site

5 Sample Collection for Future Work

Soil Collection

Samples of “clean” and “thorium-containing” soil, runoff water and sediment, and plants were collected during the field activities at TS4. Two barrels of clean soil (near background activity levels of ~2 pCi/g) were collected from a 1.2- by 1.8-m (4-ft by 6-ft) square (to a depth of 20 to 25 cm (8 to 10 in.)) located outside the perimeter fence of TS4. This soil will be used for laboratory characterization and stabilization studies. Soil was also collected from “hot spots” in the area surrounding the helicopter for desorption, column leaching, and stabilization studies. In addition, the soil cores harvested for subsurface characterization were saved for future laboratory studies.

Water and Sediment Collection

Runoff may be a significant pathway for thorium migration; therefore, a water and sediment sampling system, the Isco 6712 Portable Sampler, was placed in the largest arroyo adjacent to the training site. Although several arroyos exist west of the site, water samples were collected from the largest arroyo because it appears to receive the majority of overland flow.

The Isco 6712 Portable Sampler was programmed to sample when a liquid level actuator’s conductance changed in the presence of runoff water. A rain gauge unit was also present to act as a backup trigger in case the liquid level actuator failed. Twenty-four 1-L bottles were positioned inside the unit to collect rainwater according to a preprogrammed routine (Appendix C). One bottle was assigned for each sampling event. The unit was placed approximately 8 m (25 ft) above the sampling point on a hill adjacent to the arroyo (Figure 17). A shelf was dug out of the incline and heavy link chain attached to the unit. Stakes attached to the chain were driven into the soil to prevent washout. A 12-V battery was placed in an all-weather cover box and then partially buried in the ground. The battery was recharged by an attached solar panel.



Figure 17. Isco portable water and sediment sampler. The Isco unit was set up in the largest arroyo to collect runoff water and sediment

An area that allows water to pool approximately halfway down the arroyo was chosen for placement of the liquid level actuator and intake line. Both the actuator and intake line were placed in a small, shallow opening. The stainless steel screen at the end of the intake line was affixed to the clamped liquid level actuator. The clamp was then staked to provide support for both mechanisms. A significant rain event did not occur from the start of field investigations to the date of publication of this report. However, the unit was left in standby mode at TS4 and is being monitored by DNWS personnel at Kirtland AFB.

Plant Collection

It is possible that plants on the training site take up thorium or some of its progeny (daughter products). Thorium-laden plant debris (e.g., tumbleweeds) could possibly be transported from the site during strong winds. This could represent another possible means of thorium transport. To determine to what extent (if any) plants are taking up radionuclides at TS4, plant samples, both roots and shoots, were harvested from each of the 33 subsurface soil sample locations (Figure 18). Laboratory analysis of plant samples was not within the scope of work of this project. However, plant samples will be analyzed for radionuclide content during follow-up work at ERDC.



Figure 18. Plant sample collection and labeling

6 Conclusions

The following conclusions can be drawn:

- a.* The ERDC-developed Mobile Multisensor Radiological Data Acquisition System configured with an array of four gamma sensors collocated with GPS x-, y-, and z-coordinates was successfully deployed at TS4, Kirtland AFB; and provided the simultaneous mapping and in situ quantification of surface thorium and thorium progeny radiation activity.
- b.* Natural radiation background measured 2 pCi/g (± 2 pCi/g) for offsite Kirtland soil. Elevated levels of gamma activity were defined for TS4 soil as gamma activity exceeding 4 pCi/g. The highest levels of gamma activity were measured in soils in the vicinity of the site helicopter body. Probable routes of thorium migration were identified by contour mapping gamma activity of thorium progeny in surface soils. Low levels of gamma activity were verified by onsite radiological laboratory analysis of soil samples collected from suspect locations.
- c.* An evaluation of the data indicated that thorium-contaminated surface soils at TS4 are migrating to the southwest and west directions. Elevated activity (three to five times background) was measured near the boundary of the southwestern quadrant of the site.
- d.* Vehicular traffic between the site helicopter body and the east gate has likely spread some thorium-contaminated soil toward the east gate portal.
- e.* Thorium contamination appears to be in the top 91 cm (3 ft) of soil.
- f.* Vegetation was found growing in thorium-contaminated soils of TS4 and may be contaminated with thorium or thorium progeny in roots and shoots. Strong winds could possibly transport thorium-laden dead plant materials within and beyond site boundaries.

7 Recommendations

The following recommendations are made:

- a.* Stabilize TS4 soils with elevated levels of gamma activity (i.e., TS4 soils with gamma activity exceeding 4 pCi/g) to prevent offsite migration of thorium and thorium progeny contaminants.
- b.* Conduct laboratory analysis of vegetation growing in thorium-contaminated soils of TS4 to determine if thorium or thorium progeny have been absorbed in roots and/or shoots.

Appendix A

Health and Safety Program

HEALTH AND SAFETY PLAN FOR ASSESSMENT OF THORIUM
CONTAMINATION AT RADIATION TRAINING SITE 4, DEFENSE
NUCLEAR WEAPONS SCHOOL, KIRTLAND AIR FORCE BASE, NEW
MEXICO

PHASE I: SITE SURVEY

OCTOBER 2001

Prepared for

**DEFENSE NUCLEAR WEAPONS SCHOOL
KIRTLAND AIR FORCE BASE**

Clinton Abell, Capt, USAF, BSC
Kirtland AFB Radiation Safety Officer

Date _____

ACRONYMS

ACGIH	American Conference of Governmental Industrial Hygienists
AFB	Air Force Base
ALARA	As Low As is Reasonably Achievable (human radiation exposure)
AMC	U.S. Army Materiel Command
ATV	All-terrain vehicle
CPR	Cardiopulmonary Resuscitation
DNWS	Defense Nuclear Weapons School
EPA	Environmental Protection Agency
ERDC	U.S. Army Engineer Research and Development Center
G-M	Geiger-Mueller
GPS	Global Positioning System
HEPA	High Efficiency Particulate Air
HSO	Health and Safety Officer
HSP	Health and Safety Plan
MSDS	Material Safety Data Sheet
NaI	sodium iodide
OSHA	Occupation Safety and Health Administration
PEL	Permissible Exposure Limit
PPE	Personal Protective Equipment
RPP	Radiation Protection Plan
RSO	Radiation Safety Officer
SIT	Stevens Institute of Technology
SPF	Sun Protection Factor
TLD	Thermoluminescent detector
TLV	Threshold Limit Value
TS4	Training Site 4
USACE	U.S. Army Corps of Engineers

Introduction

This Health and Safety Plan (HSP) has been prepared for employees involved in work related to a project titled "Assessment of Potential for Offsite and Vertical Migration and Soil Stabilization Technology for the Containment of Thorium at a Training Site at Kirtland Air Force Base." The project is a joint effort by Stevens Institute of Technology (SIT) and the U.S. Army Corps of Engineers (USACE) Engineer Research and Development Center (ERDC) as part of the U.S. Army Materiel Command (AMC) sponsored RangeSafe Program. The field effort pertaining to this project is divided into two phases. Phase I involves a radiological survey of the Defense Nuclear Weapons School (DNWS) radiation training site 4 (TS4), Kirtland Air Force Base (AFB), Albuquerque, New Mexico. This document, the Work Plan, and the Radiation Protection Program form the health and safety program governing Phase I of this project.

This HSP provides the safety and health procedures specific to radiation surveying activities at TS4. It also provides specific information about the controls that will be employed to protect site workers from excessive exposure to radiation.

Site location

TS4 is a DNWS radiation training site northwest of the Tijeras Arroyo Golf Course, Kirtland AFB, Albuquerque, New Mexico. The TS4 radiation training site encompasses an area of 4.2 ha (10.3 acres) and is surrounded by a chain-link fence posted with radiation hazard signs.

Site history

Thorium oxide sludge was imported from Brazil and applied to eight radiation training sites that totaled approximately 33.56 ha (82.94 acres) at Kirtland AFB. The eight sites established by the DNWS to train military personnel in alpha radiation monitoring and decontamination were designated as TS1 to TS8. Thorium, a low-level radioactive substance, was used to simulate plutonium contamination from nuclear weapons accidents. The sludge was mixed and raked over the topsoil of the training sites. Sites TS5 through TS8 are currently undergoing remedial actions that involve excavation and offsite disposal. Sites TS1 through TS4 are active sites and are used several times per year for personnel training by the Department of Energy, Department of Defense, Federal Emergency Management Agency, and other Federal and State agencies in emergency operations at nuclear accident sites. Of the active sites, TS4 is available for site investigation and pilot studies.

Although TS4 is an active site, it is rarely used for training. However, TS4 may be altered in the future to simulate an urban environment. A simulated urban environment will require erection of various kinds of structures, paved roads, etc. Hence, it is essential that a thorium management plan for the site be implemented that will allow long-term use of the site and at the same time minimize vertical and horizontal migration of radiological contaminants outside site boundaries.

Scope of Work and Schedule

The objective of the Phase I field effort is to characterize the site for vertical and lateral migration of thorium. During Phase II, soil, plant, water, and sediment samples will be collected to investigate the means of thorium transport. Methods to stabilize thorium contamination will be investigated during Phase II. Contamination at TS4 is limited to thorium-232 and its decay progeny. No chemical contaminants have been identified at these sites.

Scope of work

A detailed scope of work appears in the Work Plan for this project. Field activities in Phase I will include the following:

- A survey of the fenced area will be conducted using an array of sodium iodide (NaI) gamma detectors in order to obtain gamma activity and spectral gamma radionuclide speciation data. Gamma activity will be co-registered with Global Positioning System (GPS) data and will be used to formulate a map showing the location and gamma activity levels resulting from thorium contamination.
- A survey of areas outside the fence will be conducted where radiation above background is detected at the fence line. This data will be used to better define the extent of lateral thorium migration. In particular, an arroyo located adjacent to the site is possibly an avenue of contaminant migration offsite. A water and sediment sampling device will be installed adjacent to the fenced area to collect runoff from the arroyo. These samples will be collected at a later date for analysis for thorium content in runoff water and sediment. A weather station will be placed onsite to document rainfall events.
- Health physics activities will be conducted and documented by the onsite Radiation Safety Officer (RSO). These activities include the decontamination of personnel and equipment in addition to radiation and air monitoring. Monitoring will include airborne particulate monitoring and personal dosimetry. General air monitoring will be performed daily or whenever site worker activities have the potential for releasing airborne radioactivity. Workers inside the fence will wear personal air samplers. Air sample filters will be measured daily for radioactive counts to determine potential worker exposure to airborne radioactive particles. Pancake (Geiger-Mueller) (G-M) and smear counting will be used for personnel frisking and surface contamination monitoring. Thermoluminescent detectors (TLDs) will be used to monitor worker exposure to external radiation.

Schedule

Phase I field activities are anticipated to take place during October 2001 over approximately a 5-day period. It is anticipated that 10-hr work days will be conducted during evening hours as a precaution against heat.

Purpose of the HSP

The purpose of this HSP is to address known and reasonably anticipated health and safety hazards to ERDC and SIT employees conducting field activities. This HSP also provides information to site personnel to help prevent or minimize personal injuries and illnesses. This HSP also addresses the proper operation and use of equipment, supplies, and property.

Amending the HSP

The evaluation of hazards, levels of protection, and procedures specified in this plan are based on the best information available at the time of this writing (June-August 2001). It is recognized that site conditions may change; therefore, it is imperative that safety measures be thoroughly assessed by the RSO prior to any onsite activities.

This HSP will be modified/amended to address work activities not covered by this plan, or if the provisions specified herein are not adequate to protect the health and safety of site personnel. Modifications shall be accomplished by consultation with the onsite RSO, the Kirtland AFB Health and Safety Office, the ERDC Health and Safety Office, and the SIT Health and Safety Office.

Applicable Regulations and References

The Hazardous Waste Operations and Emergency Response standard (regulation) (29 Code of Federal Regulations 1910.1200, the Hazard Communication Standard) is applicable to site TS4 field investigation activities. A copy of this standard is provided in Attachment 3 of this HSP. Kirtland AFB field investigation activities will receive added precautions due to the radioactive nature of the contamination.

All employees working onsite at TS4 are required to read and understand this HSP. All employees working onsite at TS4 must sign a statement stating that they have read and understand this HSP. All visitors observing onsite work at TS4 are required to read and understand this HSP and must also sign a statement attesting to this requirement. All site workers will implement and enforce the requirements of the HSP.

Site-Specific Conditions

Radiation hazard

The radioactive contaminants of TS4 provide radiation hazards that are unique to this site. A Radiation Protection Plan (RPP), required for such a project, has been developed. The RPP provides detailed information about the hazards due to exposure to radioactive contaminants and provides the exposure monitoring program for this site. It is summarized as follows.

- The primary hazards are thorium-232 and its decay progeny. This element decays to ten different isotopes before it stabilizes. Its decay process liberates radon-220 gas that is an alpha emitter. Its decay process also liberates alpha, beta, and gamma radiation. Several of its decay progeny emit gamma radiation. Thorium-232 reaches a state of equilibrium with its decay progeny isotopes after approximately 40 years.
- Uranium-238 and its decay progeny are present at TS4; it liberates radon-222 gas. Alpha, beta, and gamma radiation are produced by U-238 and daughters.
- Radon gas is a significant health concern due to the alpha particle's ability to damage lung tissue, including the potential to cause lung cancer. However, radon-220 is a less important source of exposure to humans than radon-222 due to its short half-life and limited ability to migrate.
- Daily air monitoring will be performed to quantify the amount of alpha radiation being generated by invasive activities (in Phase I, limited to driving the surveying equipment over the site). The monitoring will be accomplished by collecting particulate samples using personal sampling pumps (SKC Universal XR44 or equivalent). The samples will be analyzed daily using a 43-10-1 scintillation counter to provide gross alpha radiation data. This particulate monitoring will be considered a surrogate to direct monitoring of thorium-232.
- Onsite workers will be issued individual TLDs to monitor their external exposure. The TLDs will be worn under protective clothing to prevent possible contamination of the TLD from dirt or airborne dust. All TLDs, as well as controls, will be placed in the support zone when not in use. TLDs will be provided and read quarterly by a third-party vendor certified by the National Voluntary Laboratory Accreditation Program.
- The amount of time each worker is exposed to radiation above background will be determined by having them record times in and out of TS4 on a sign-in/sign-out sheet. All work activities taking place inside the fenced area of TS4 will be carefully planned to minimize worker exposures.
- The extent of invasive work tasks for Phase I of this project will be limited to driving the data acquisition sensing array over the site and the collection of a select number of surface samples (after analyses, these

samples will be returned to their original location in their original form (i.e., no mixed wastes). If dust becomes a problem, a sprayer will be mounted to the front of the sampling vehicle to dampen the ground just before the wheels roll over it. Precaution will be taken not to create a situation that causes damp soil to adhere to vehicle tires. Personnel will start in Level D personal protective equipment (PPE). If at any time air monitoring indicates a high airborne thorium-232 level above background or if winds appear to generate airborne particles, Level C PPE will be worn.

- Level D PPE for this project requires:
 - Steel-toed safety shoes
 - Cotton coveralls
 - Cotton or other cloth overgloves (latex or nitrile inner gloves will be worn underneath if there is a problem with dust getting inside overgloves)
 - Safety glasses with side shields or goggles
- Level C PPE for this project requires:
 - Half-face air purifying respirator with P100 (high-efficiency particulate air (HEPA)) filter
 - Steel-toed safety shoes
 - Safety goggles
 - Tyvek shoe covers
 - Coveralls (either Tyvek® or Kleenguard®)
 - Latex or nitrile inner gloves
 - Cotton or other cloth overgloves
 - Hair covers
- At the port of exit from the fenced area, work boots and coveralls will be vacuumed with a HEPA vacuum cleaner. Work boots and cotton coveralls will be stored in a secure area when not in use and will not be carried offsite until decontaminated at the end of the survey. Spent PPE will be containerized and disposed of in accordance with Kirtland AFB disposal procedures.
- The radiation hazard from radioactive materials located at TS4 is not expected to be strong enough to result in an acute onsite radiation injury or to cause illness to site workers. However, ingestion of TS4 soil may cause health risks. Therefore, ingestion of TS4 soil will be prevented by the use of PPE described within this HSP. Injury or illness occurring at the site could be the result of other factors. It is possible for an injured or ill worker to have contaminated soil adhere to his/her PPE or exposed body. For this reason, medical emergencies will require decontamination as described below. Emergency medical service (local 24-hr hospital) has been provided with information concerning this project and the potential for radioactive soil contamination on injured or ill workers (body and/or

clothing). Emergency telephone numbers are provided in the Emergency Contact Numbers section of this HSP (p. A21).

- Decontamination will include the removal of outer clothing and gently washing affected body parts with soap and water. Decontamination solutions and spent PPE will be containerized and disposed of in accordance with Kirtland AFB disposal procedures.

Heat stress and exposure to the sun

The stress of working in a hot environment can cause a variety of illnesses including heat exhaustion or heat stroke; the latter can be fatal. Personal protective equipment such as Environmental Protection Agency (EPA) Level C and Level D protection can significantly increase heat stress. However, heat stress may occur in people wearing regular, permeable work clothing. Field work associated with this study is scheduled to occur in the cooler evening hours. However, heat stress is still a potential concern at the site. To minimize or prevent heat stress, frequent rest periods and controlled beverage consumption to replace body fluids and electrolytes will be implemented.

Quantitative physiological monitoring for heat stress will be conducted as prescribed in the chart below. Physiological monitoring for heat stress includes heart rate as a primary indicator and oral temperature as a secondary indicator. The frequency of monitoring depends on the ambient temperature and the level of protection used onsite. To determine the initial monitoring frequency, after a work period of moderate exertion, the following information shall be used:

<u>Adjusted Temperature*</u>	<u>Level D</u>	<u>Level C</u>
90 °F or above	after 45 min	after 15 min
87.5 to 90 °F	after 60 min	after 30 min
82.5 to 87.5 °F	after 90 min	after 60 min
77.5 to 82.5 °F	after 120 min	after 90 min
72.5 to 77.5 °F	after 150 min	after 120 min

* Adjusted air temperature (°F) = observed temp + (13 × percent sunshine). Air temperature measured with a bulb shielded from radiant heat; percent sunshine is the time sun is not covered by clouds thick enough to produce a shadow (100 percent = no cloud cover and a sharp, distinct shadow; 0 percent = no shadow).

The following procedures and action levels are to be used for the physiological monitoring of heat stress:

Heart rate: Count the radial pulse during a 30-sec period as early as possible in the rest period. If the heart rate exceeds 110 beats per minute at the beginning of the rest period, shorten the next work cycle one-third and keep the rest period the same. If the heart rate exceeds 110 beats per minute at the next

rest period, the following work cycle shall be shortened by one-third and oral temperature shall also be monitored during subsequent rest periods.

Oral temperature: Use a clinical thermometer (3 min under the tongue) to measure the oral temperature at the end of the work period (before drinking). If oral temperature exceeds 99.6 °F, shorten the next work cycle by one-third without changing the rest period. If oral temperature exceeds 99.6 °F at the beginning of the next rest period, shorten the following work cycle by one-third. Field personnel will not wear EPA Level C protection when oral temperature exceeds 100.6 °F.

Field personnel will work in teams and will watch for symptoms of heat stress. If symptoms of heat stress are observed, appropriate action will be taken immediately.

Some of the symptoms which indicate heat exhaustion are:

- | | |
|-------------------|---------------------|
| * Clammy skin | * Weakness, fatigue |
| * Lightheadedness | * Confusion |
| * Slurred speech | * Fainting |
| * Rapid pulse | * Nausea (vomiting) |

If these conditions are noted, the following steps should be performed:

- Remove the victim to a cool and uncontaminated area.
- Remove protective clothing.
- Give water to drink, if conscious.

Symptoms that indicate heat stroke include:

- | | |
|--|--------------------|
| * Staggering gait | * Mental confusion |
| * Hot skin, temperature rise
(yet may feel chilled) | * Convulsions |
| * Incoherent, delirious | * Unconsciousness |

If heat stroke conditions are noted, immediately perform the following steps:

- Remove victim to a cool, uncontaminated area.
- Cool the victim, whole body, with water, compresses, and/or rapid fanning.
- Give water to drink, if conscious.
- Transport the victim to the designated medical facility for further cooling and monitoring of body functions. Heat stroke is a medical emergency!

When working outdoors, even on seemingly cloudy days, exposure to ultra-violet radiation can result in sunburn. Workers wearing the minimum level of PPE at TS4 will be fairly well protected against sunburn, except for their faces. It

is possible that workers will be wearing respirators that will cover their faces for a portion of the work, but exposure may still be an issue. For this reason, it is recommended that workers use sunscreen and wear a hat to protect the exposed skin against sunburn. The higher the sun protection factor (SPF), the better. Exposed skin will likely include the back of the neck, top of the ears, nose, cheeks, and forehead as well as forearms and hands. Should a worker experience a sunburn, first aid treatment should be administered in accordance with the booklet in the first aid kit on the site.

Biohazards

Potential biological hazards at TS4 include snakes, scorpions, fleas and ticks, poisonous and prickly plants such as cactus, and hantavirus.

Spiders, scorpions, snakes, and fleas exist in cool, dark, moist areas. The potential for encounters exist when reaching into dark, covered places. Such places include storage of site supplies. Suggestions for control include using a long stick to break apart webs or loosen soil from certain areas. A flashlight should also be used when reaching into a dark area. Field personnel shall be aware of their surroundings and avoid contact with all animals and insects.

Rattlesnakes and scorpions are indigenous to New Mexico. Daily safety meetings will include a reminder to be on the lookout for rattlesnakes and scorpions. Most snakes and scorpions are not generally aggressive; however, if the temperature is very warm, they may already be irritated and encountering you may put them over the edge. Do not attempt to handle a snake. Rather, see if the snake will leave on its own; if not, contact the local animal control at (505) 768-1975.

It should be noted that the American Red Cross does not advocate the use of snakebite kits for snakebite injuries. Rather, experience has shown that the victim has a better chance of recovery without permanent damage when the site of the wound is immobilized and the victim rushed to the closest emergency medical facility (preferably within 30 min).

Poisonous plants such as poison ivy and poison oak are not indigenous to Albuquerque. However, pricks from cactus spines do pose an infection hazard and a mechanism for contaminant injection. A visual site inspection and identification of cactus plants should be completed prior to the commencement of work so that all individuals are aware of their location.

Hantavirus has resulted in several deaths in the southwestern part of the United States. While there may not have been any outbreaks or notices of the virus at a particular project site, field team members should be aware of the cause and potential control methods. The hantavirus has been shown to be transmitted through the aerosolization of dried rodent excreta. The newly recognized hantavirus-associated disease begins with one or more symptoms including fever, muscle aches, headache, and cough and progresses rapidly to severe lung disease, often requiring intensive care treatment. To control potential contact with dust that may be carrying the rodent excreta, the field team will conduct a visual

survey of the area around each site to note whether rodents are living in the area. If it is determined that nondomesticated rodents may be living near the work area, or the area is affected by wind blowing dust into the work area, dust suppression techniques and/or respiratory protection (dust mask or dual cartridge air-purifying respirator with dust filters) will be required. The Centers for Disease Control, Atlanta, Georgia, operate the hantavirus Web site at <http://www.cdc.gov/>.

Cases of plague have been reported in New Mexico in recent years. Plague is contracted from a bite of an infected rodent flea, primarily in the months between May and September. Rodents and areas with known rodent populations will be avoided where possible.

Multiemployer Work Sites

Work will be conducted under this HSP at Kirtland AFB by employees of the ERDC, Alion Science and Technology, and the SIT and will follow provisions of the Occupational Safety and Health Act. This HSP is provided to ensure that acceptable health and safety practices, work conditions, and PPE are maintained and available during the Kirtland AFB field study for all onsite employees. Employee training is the responsibility of respective employers and must be provided to ensure the safety of onsite workers. All employees and employers will engage in a cooperative effort to create a safe working environment.

Unsafe Acts or Conditions

All employees shall immediately correct any and all unsafe acts or conditions that are brought to attention. All work will be discontinued until the unsafe act(s) and/or condition(s) are corrected to the satisfaction of the onsite project coordinator under advisement of the RSO.

All employees will follow the guidance below in addressing potentially unsafe acts or conditions.

Threat of injury or death

In the event of threat of injury or death:

- Remove workers immediately from the danger or hazard zone.
- Stop work immediately until unsafe condition is corrected.
- Notify the onsite project manager.
- Record in the daily report the time and to whom any verbal or written notices were given.
- Document with photographs where applicable.

Differing opinions

When a difference of opinion occurs between workers concerning the interpretation of safety practices or procedures, work shall not start or continue until the safety practices or procedures in dispute are resolved to the satisfaction of the onsite project coordinator under advisement of the RSO.

Reporting unsafe conditions

If any site worker or visitor observes conditions that expose themselves or other workers to hazards that are likely to cause harm, they must immediately report the hazard to the onsite Health and Safety officer (HSO) and/or RSO as well as the onsite project coordinator so that prompt corrective action can be taken to eliminate the hazard. In cases of imminent danger, any person onsite may stop an activity to prevent serious harm to personnel, property, or equipment.

Disciplinary action

Employees refusing or repeatedly failing to comply with job safety requirements will be reported by the onsite project coordinator to offsite supervisory personnel for disciplinary action, which, at ERDC's discretion, may include employee removal from the jobsite.

Safety Suggestions

The project has an "open door policy" and encourages site personnel to make suggestions to improve safety. Suggestions are welcome and may be made by any person conducting or observing work, or affected by work onsite. Suggestions may be communicated verbally to the onsite project coordinator or the onsite HSO and/or RSO.

Roles and Responsibilities

Management commitment

It is the policy of ERDC, Alion, and SIT to provide a safe and healthful work environment for all employees. The ERDC, Alion, and SIT work under the fundamental principle that many accidents causing injuries and illness are **preventable**. Management will provide safety training to employees to help onsite workers recognize and prevent unsafe acts and conditions. The health and safety program embodied in this HSP has been developed in accordance with relevant occupational safety and health regulations and requirements.

Safety and loss prevention are a direct responsibility of employees on this project. Each employee has the responsibility to provide a safe and healthful work environment. This shall be achieved through strict adherence to the requirements of this site health and safety program and associated addenda.

All personnel shall, through personal example, create a work climate in which everyone develops a concern not only for their own safety and health, but also for the safety and health of their fellow workers and the environment. The knowledge of boundary conditions concerning the health and safety program by all personnel is vital. Common sense and good judgment always need to be applied to site work. It is intended that the health and safety guidelines contained in this HSP or subsequent addenda must be adhered to and are not open to innovative interpretation.

Project team

The efforts of multiple organizations will be needed to complete this project. Each individual assigned to the project is responsible for conducting his/her job in a safe and healthful manner. In order to facilitate the implementation of this HSP and the site safety and health program, it is necessary to assign key responsibilities to specified individuals. The Work Plan for TS4 specifies project details, the team, and their responsibilities. In summary, the responsibilities will be delegated as follows:

Radiation Safety Officer: Terry Coggins (Mississippi State University), radiation safety and air monitoring. Research Physicists: Cliff Morgan, Morris Fields, and John Ballard (ERDC), sensing technology. Onsite Project Coordinator: Melissa Shettlemore (SIT), project oversight. Research Engineer: Rebecca Manis (SIT), project assistant. Electronics Engineer: Chuck Hahn (ERDC), transport of field equipment and operational and technical support.

Radiation safety officer

Terry Coggins will serve as both the HSO and RSO on this project. His duties include the following:

- Resolves all issues related to health and safety.
- Conducts daily safety meetings.
- Participates in project meetings.
- Conducts/documents periodic site safety inspections.
- Ensures that personnel wear the prescribed level of personal protective clothing and performs correct decontamination procedures in accordance with the Radiation Protection Program.
- Suspends work that could adversely affect health and safety of workers.

- Prepares incident reports for work-related injuries, illnesses, or losses involving the environment or property (see Attachment 1).
- Maintains first aid supplies and rescue equipment.
- Ensures maintenance of fire extinguishers.
- Conducts initial radiation surveys and communicates results to site personnel.
- Conducts continuous onsite radiation monitoring to document possible personnel exposure to radiation.
- Makes recommendations to adjust PPE ensembles to balance risks of wearing protective gear versus other factors such as heat stress, decreased visibility, and communication.
- Monitors decontamination activities to ensure that employees are not spreading contamination outside approved work zones.
- Provides external monitoring for the waste containers.
- Conducts onsite monitoring and makes recommendations for the protection of personnel outside of regulated work zones.

Onsite project coordinator

Melissa Shettlemore will serve as the Onsite Project Coordinator for this project. Her duties will include the following:

- Maintains necessary health and safety documentation and records.
- Maintains incident reports.
- Serves as onsite project supervisor.
- Maintains visitor log /entry log for workers entering the fenced area.
- Maintains current cardiopulmonary resuscitation (CPR) and first aid training, and provides such care in the event that it is needed.

Site Visitors

Visitors will be permitted to visit outside the fence line of the project site with prior approval by the onsite project manager and RSO. Visitors entering the restricted areas must read the HSP and must sign a statement that they have read and understand the HSP for this project. Visitors must attend the daily safety meetings conducted at the beginning of each work period, or be given a briefing by the RSO. Site visitors must have the necessary training to access areas that are restricted due to specific training and PPE requirements.

Training, Communications, and Meetings

Safety training requirements

Health and safety training is an integral part of the total project health and safety program. The objectives of such training are to educate workers about the potential health and safety hazards associated with working at the project site. The RSO will instruct workers about the hazards of the project and site before allowing them to work. An orientation should include an overview of this HSP, the RPP, emergency information, and other relevant information that would assist the safety and health of the person(s) entering the project site.

Training has been formulated by Luke McCormick, a safety officer for the USACE, and approved by Lt. Derek Favret of the DNWS. The training is outlined in the Radiation Protection Program. The ALARA (as low as reasonably achievable) training includes the following principles:

- Types of radiation.
- Units of measurement.
- Biological effects and risks.
- ALARA concept.
- Protective measures and requirements.
- Exposure limits.
- Reporting instructions and emergency response.
- Posting and labeling.
- Radiation dosimetry.

The RSO will verify that all workers have received necessary training.

In addition, workers who operate the all-terrain vehicle (ATV) will have taken an ATV safety course that satisfies USACE requirements.

Methods of communication to employees

Project safety information will be communicated to site employees in the following manner:

- Offsite training described above will provide general health and safety information, prior to arriving at the site.
- A project briefing will be given on the first day of the site work.
- Each site worker is required to read and understand this HSP and the RPP and to sign a statement attesting to this requirement.

- Each day prior to work there will be a safety meeting conducted to inform personnel of the day's activities and potential hazards, and to remind them of the control program.
- Other communications in the form of verbal, written, or audiovisual information will be provided as needed.

Meeting schedule

The RSO will conduct safety meetings with workers at least once daily to emphasize safety. A site orientation meeting to acquaint workers with the project will be conducted prior to the start of the project.

Safety Inspections/Evaluations

It is the responsibility of the RSO to ensure safety inspections are carried out periodically. This includes conducting visual inspections of ongoing work to look for potential safety and health problems. When problems are identified, actions shall be taken to correct or address the problem as soon as possible. A written record of such issues shall be kept and reported in daily reporting documents.

Accident Investigation and Reporting

Accidents and incidents (including near misses) will be documented by the RSO. All accidents shall be reported immediately via telephone to the ERDC Safety Office and Kirtland personnel (including Lt. Derek Favret and the base RSO - contact numbers are listed on page A21 of this HSP and will be posted onsite). The accident shall be documented in written form and provided to the Onsite Project Coordinator and the ERDC Safety Office. A copy is to be kept in a project file onsite.

Documentation and Postings

The following documents are to be kept onsite:

- A copy of the HSP shall be posted in all onsite vehicles and in onsite facilities used during this project.
- Material Safety Data Sheets (MSDS) for hazardous materials used at this site.
- A copy of the "Route to the Hospital" map and emergency medical contact information in this plan.
- Project documentation in a logbook or other approved recordkeeping format. This will include daily safety observations, any deviations from the safety program, and any corrective actions initiated.

- Personal acknowledgement form indicating that each project employee has read and will abide by the project safety program (see Attachment 2).
- Daily safety meetings documentation.
- Accident/incident investigations.

Office Environment

Fire protection plan

Employee safety training will cover the basic use of portable fire extinguishers. Two 1.1-kg (2.5-lb) ABC fire extinguishers shall be available in the office building. It is the responsibility of the RSO to ensure that fire extinguishers are charged and in working order prior to project startup.

In the event of fire, the facility shall be evacuated immediately. Those trained to use fire extinguishers may attempt to extinguish the fire if it is safe to do so. The fire department shall be notified immediately via 911 or other telephone numbers. All employees shall meet to be counted at a designated location. The RSO will conduct the head count.

Employees will be alerted to an emergency evacuation. When out in the field, notification will either be by direct visual or verbal contact, or by means of a horn. The horn may be on a piece of equipment or a portable air horn, as deemed necessary by the RSO.

Electrical hazards

Caution shall be exercised around marine battery and generator connections. Avoid using extension cords for fixed electrical devices. When using a surge protector, use only one per outlet (i.e., do not string them together like extension cords). Electrical cords must not be near sources of heat and water and must not be run under rugs. The integrity of three-wire electrical plugs must be maintained. The removal of the third prong (ground) on grounded plugs is prohibited. Damaged electrical equipment or cords will not be used. All appliances will be turned off when they are not in use.

Common Field Safety Issues

This section provides safety information common to all field projects regardless of size, hazardous environment, or client.

Housekeeping and storage of materials

Housekeeping and cleanup shall be maintained by site workers in all areas. The project manager will inspect the work areas frequently and at the end of each

day to ensure housekeeping is maintained. At a minimum, the following must be ensured:

- Eliminate trip and impalement hazards.
- Secure incoming materials to prevent tipping or rolling.
- Secure trash in covered containers.
- Provide drinking water in tightly closed containers with disposable cups.
- Mark outlets carrying nonpotable water, if any.
- Ensure that workers are provided with a restroom facility.
- Provide workers with a clean and safe area to take breaks.

Storage of flammable materials

Flammable liquids shall be kept in ERDC-approved safety cans. Each container shall be clearly labeled and closed when not in use.

Flammable and combustible materials shall be stored away from sources of ignition and areas where hot work will be performed. Flammable material storage areas should be clearly marked with signs denoting "FLAMMABLE – No Smoking or Open Flames within 50 ft" (15 m). Flammable and combustible materials shall be stored a minimum of 6 m (20 ft) from a building or structure. The storage area shall be graded in a manner to direct possible spills away from buildings or other exposures or shall be surrounded by a curb at least 0.15 m (6 in.) high. One portable dry chemical fire extinguisher (10A-60 B:C) shall be located within 3 m (10 ft) of the storage area.

Hazard communication and MSDSs

A written Hazard Communications program that complies with the requirements of 29 CFR 1926.59 and 29 CFR 1910.1200 will be available on the project site. MSDSs for projects that are used on the site (e.g., cleaners, fuel gases, etc.) will also be available on the jobsite for review by workers. All containers of hazardous materials are required to have a written warning that includes its contents, a health hazard warning, and a physical hazard warning.

Fire prevention plan

In the field it is important to plan ahead for potential fires. This includes identification of a safe place of refuge, ability to contact fire department personnel, and ability to try to extinguish fires onsite before they get out of control. Each day during the safety meetings a safe place of refuge shall be identified. Use of cellular phones will be permitted in the work zone and will allow for direct contact with fire department personnel. In accordance with the

paragraph below, fire extinguishers shall be available for use by trained personnel.

Clear access to all available fire-fighting equipment should be maintained at all times. Fire prevention equipment should be inspected monthly. Fire lanes providing access to all areas should be established and maintained free from obstruction. Fire extinguishers should be a multipurpose dry chemical fire extinguisher rated not less than 2A-40 B:C. Specific areas where fire extinguishers are required are identified below:

- Where flammable materials are stored, handled, and used.
- On heavy equipment, if any.
- In shops and offices near exit doors.
- Near gasoline-powered generators and pumps.
- In jobsite vehicles.

First aid and CPR

At least one person trained to provide first aid and CPR will be required in the work/exclusion zone at all times. Such training shall be equivalent to or exceed the elements covered in the standard first aid course provided by the American Red Cross. If the training course does not cover the use of "universal precautions" as defined in the bloodborne pathogens standard under Occupational Safety and Health Administration (OSHA) (29 CFR 1910.1030), supplemental training will be needed.

The RSO, assisted by the Onsite Project Coordinator, is responsible for maintaining a clean and hazard-free area with adequate supplies to administer first aid to employees. The location of the first aid kit shall be made known to all workers. First aid supplies shall be individually sealed and stored in a weather-proof container. The contents of the first aid kit are to be checked by the RSO before work begins and at least weekly to ensure the expended items are replaced. At a minimum, the following will be maintained:

- A record of inspection of the first aid kit.
- Heat-stress rehabilitation area.
- Posting of emergency telephone response numbers, such as physician, hospital, ambulance, etc.

Site security

Before leaving the site, workers will secure all equipment. The security fence will be shut and locked at the end of each day. It is the responsibility of the Onsite Project Manager to ensure that the gate is secured.

Field sanitation

An adequate supply of potable drinking water, at least 2 L (2 qt) per person per day, will be provided for workers. Any portable containers used to dispense drinking water shall be capable of being tightly closed and equipped with a drain faucet. Water must not be dipped from containers. Containers are to be clearly marked as to the nature of their contents and not used for any other purpose. A common drinking cup is prohibited. Where disposable cups are supplied, both a sanitary container for the unused cups and a receptacle for disposing of the used cups will be provided.

Toilet facilities shall be provided for site workers. If the field office or existing toilet facilities at Kirtland AFB are not close enough to provide reasonable access to site personnel, a portable toilet facility will be brought to the worksite. If a portable toilet is provided, there must be one for every 20 workers with a door capable of being locked from the inside (this will avoid the need to supply separate facilities for men and women).

Personal Protective Equipment

All site personnel will be required to wear the following equipment onsite, regardless of task:

Item	Specifications
Exterior garments/body protection	Cotton coveralls over long pants and shirt with sleeves (no tank tops or shorts)
Foot protection	Safety-toed footwear/boots (ANSI Z41)
Gloves	Cloth or heavy leather gloves and/or latex or nitrile gloves
Eye and face protection	Safety glasses with side shields (ANSI Z87.1) or goggles
Respiratory protection	Half-face air-purifying respirator (or safety escape hood) with P100 filters if the RSO determines that a dust hazard (which could potentially be an airborne radiation hazard) is present

Emergency Assistance Information

Always provide your exact location to the 911 operator.

Kirtland Air Force Base Site OT-10, TS4, Albuquerque, New Mexico. The RSO or the Onsite Project Coordinator will be responsible for taking necessary action and contacting the appropriate emergency personnel in case of emergency.

First Aid and CPR

A first aid kit must be available at the site suitable for the number of employees expected to be present. The contents of the kit should include the following:

- Container that will ensure that all supplies are kept clean and sanitary
- Aspirin
- Nonaspirin pain reliever
- Antiseptic spray, cream, or ointment
- Band aids: adhesive bandages (5/8", 3/4", 1", snips, spots, knuckle, and fingertip)
- Triangle bandage and safety pins
- Eye wash
- Insect sting relief pads
- Inhalant
- Hand sanitizer
- Instant ice pack
- Scissors and tweezers
- Latex gloves
- CPR barricade, to prevent mouth-to-mouth contact
- First aid guidebook
- First aid tape
- 5" x 9" trauma ABD pad
- Sterile eye pads
- 3.0% hydrogen peroxide
- Gauze pads (4" x 4")
- Stretch gauze (1" and 4")
- Emergency blanket
- Sunburn pain relief spray

A kit with these contents (with exception of the CPR barricade and latex gloves, purchased separately and added to the kit for the control of bloodborne pathogens) can be purchased through safety supply catalogs. A clear face protection device will be provided for persons administering first aid.

24-Hr Emergency Hospital

Lovelace, Gibson (switchboard) (505) 262-7000
Lovelace, Gibson Emergency Room (505) 262-7222
(contact: Marti Miller)
5400 Gibson Blvd. S. E.
Albuquerque, NM 87108

Note: This facility is equipped to handle emergency situations with radiation contamination.

Emergency Contact Numbers

Ambulance 911
Fire Department 911
Police Department 911
NM Poison Control Center (UNM, north campus) (505) 843-2551
National Response Center (to report oil/chemical spills) (800) 424-8802
Local Animal Control (for snake removal) (505) 768-1975
Utilities Underground Service Alert (505) 260-1990

Lt. Derek Favret, DNWS (cellular number)	(505) 681-8766
Bioengineering, Radiation Protection (Kirtland AFB RSO)	(505) 846-4259
Kirtland AFB Safety Office (Bill Emmer, Terry Beggs)	(505) 846-4226
Kirtland AFB Command Post	(505) 846-3777
Kirtland Security Office	(505) 846-7926
Kirtland Fire Department	(505) 846-8290
ERDC Safety Office (Jerry Haskins)	(601) 634-2298

See Figure A1 for map of route to hospital.

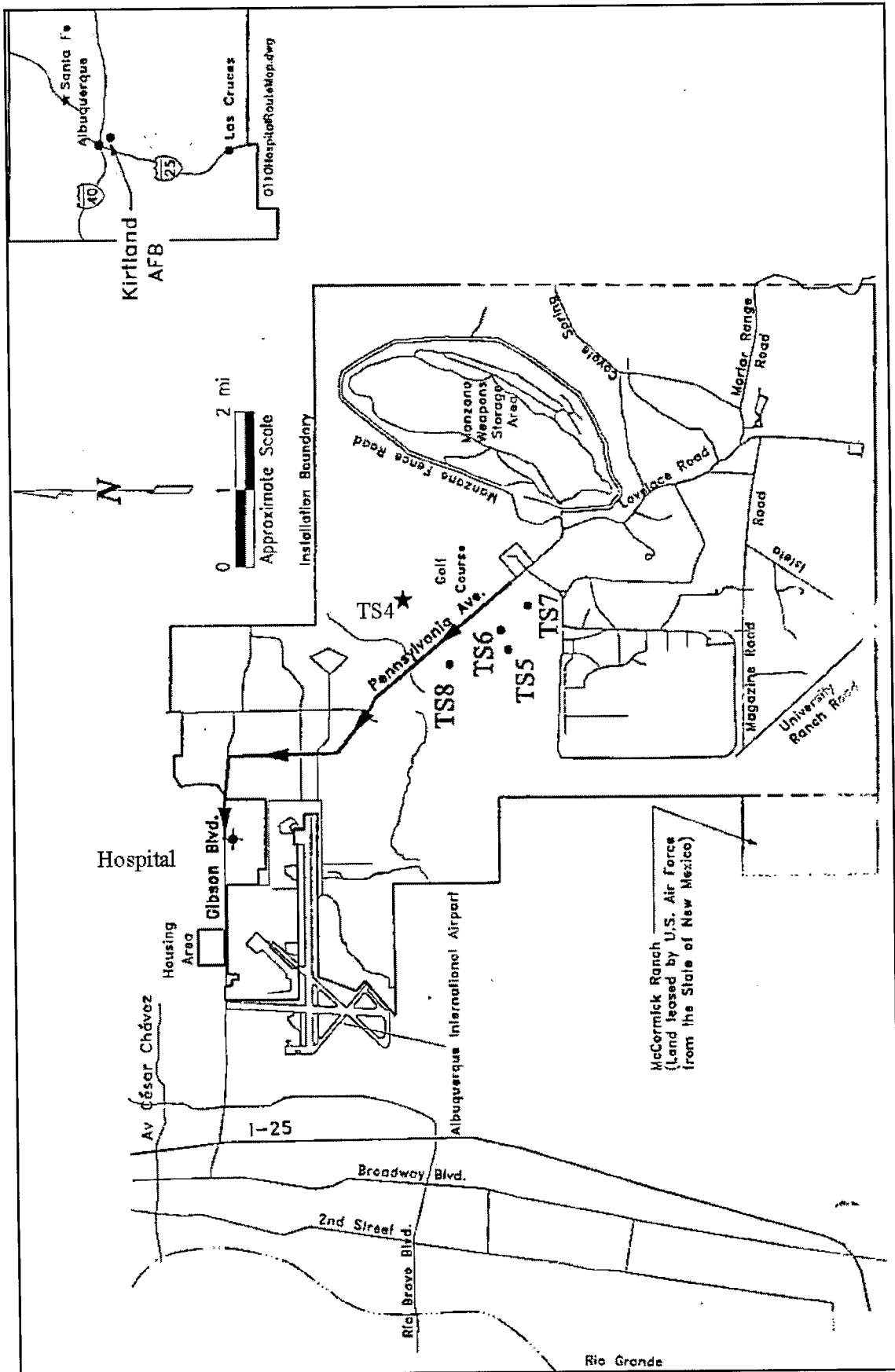

Figure A1. Map of route to hospital

ATTACHMENT 1: INCIDENT REPORT FORM

OCCUPATIONAL INJURY/ILLNESS/INCIDENT REPORT FORM

This report is for (check all that apply):

<input type="checkbox"/> Near Miss	<input type="checkbox"/> Equipment Damage	<input type="checkbox"/> Spill/Leak
<input type="checkbox"/> Fire	<input type="checkbox"/> Theft	<input type="checkbox"/> Property Damage
<input type="checkbox"/> Vehicle Damage	<input type="checkbox"/> Injury	<input type="checkbox"/> Illness
<input type="checkbox"/> Other (Describe): _____		

In the event of a fatality or the hospitalization of an individual, contact the company Health & Safety Manager immediately.

Section 1 – Employee Information

Name: _____ Title: _____ Sex: _____

Employer: _____

Birth Date: _____ SSN: _____

Phone Number: _____

Address: _____

Section 2 – Incident Information

Date of Incident: _____ Day of Week: S M T W TH F S

Time: _____

Weather Conditions: SUN CLEAR OVERCAST RAIN SNOW

Temperature: To 32 °F 32 – 50 °F 50 – 70 °F 70 – 85 °F 85 °F & Up

Wind: STILL MODERATE HIGH

Location of Incident: _____

Project Name:

Did employee leave work site? _____ If so, time employee left: _____

Section 3 – Injury/Illness Information (if applicable)

Date/Time injury reported: _____

Reported to whom? _____

Type of injury sustained (check all that apply):

- | | | |
|---|--|--|
| <input type="checkbox"/> Bruise, Contusion | <input type="checkbox"/> Electrical Shock | <input type="checkbox"/> Joint Sprain |
| <input type="checkbox"/> Chemical Exposure | <input type="checkbox"/> Fatality | <input type="checkbox"/> Laceration, Puncture |
| <input type="checkbox"/> Concussion | <input type="checkbox"/> Foreign Object in Eye | <input type="checkbox"/> Muscle Strain |
| <input type="checkbox"/> Dismemberment | <input type="checkbox"/> Fracture | <input type="checkbox"/> Suffocation |
| <input type="checkbox"/> Electrical Burn | <input type="checkbox"/> Hernia | <input type="checkbox"/> Thermal Burn |
| <input type="checkbox"/> Loss of Senses (hearing,
site, smell, etc.) | <input type="checkbox"/> Unconsciousness | <input type="checkbox"/> Other
(Specify): _____ |

Specific parts of body affected (e.g., head, left leg, right ear, index finger, etc.):

Type of illness resulted (check all that apply):

- | | | |
|---|--|---|
| <input type="checkbox"/> Cardiovascular
(heart/circulatory system) | <input type="checkbox"/> Central Nervous System
(brain/spine) | <input type="checkbox"/> Systemic (Liver, Kidney,
Heart, etc.) |
| <input type="checkbox"/> Eye | <input type="checkbox"/> Skin | <input type="checkbox"/> Hearing Loss |
| <input type="checkbox"/> Respiratory | <input type="checkbox"/> Heat/Cold Stress | <input type="checkbox"/> Other
(Specify): _____ |
-
- | | |
|--|--|
| <input type="checkbox"/> Effect of Hazardous
Substance/Material
(Specify): _____ | <input type="checkbox"/> Cumulative Trauma
Disorder (i.e., carpal
tunnel syndrome) |
|--|--|

What caused the injury of illness? (check all that apply)

- | | | |
|--|--|---|
| <input type="checkbox"/> Caught In, Under, Between | <input type="checkbox"/> Fall on Same Level | <input type="checkbox"/> Slip |
| <input type="checkbox"/> Contact w/Electrical Current | <input type="checkbox"/> Inhalation of Material | <input type="checkbox"/> Struck Against |
| <input type="checkbox"/> Contact w/Material | <input type="checkbox"/> Ingestion of Material | <input type="checkbox"/> Struck By |
| <input type="checkbox"/> Contact w/Plant, Animal, Insect | <input type="checkbox"/> Involuntary Body Reaction | <input type="checkbox"/> Trip |
| <input type="checkbox"/> Contact w/Temperature Extremes | <input type="checkbox"/> Over Exertion | <input type="checkbox"/> Other |
| | | (Specify): _____ |
| | | _____ |
| | | _____ |
| <input type="checkbox"/> Fall from Higher Elevation | <input type="checkbox"/> Rubbed or Abraded | |

Method of Treatment

- | | |
|---|--|
| <input type="checkbox"/> Onsite First Aid | <input type="checkbox"/> Clinic/Doctor First Aid |
| <input type="checkbox"/> Doctor's Care | <input type="checkbox"/> Hospitalization |

Name of service, physician, location:

Phone number: _____

Address:

Will injury-illness result in restricted activity?

- | | | |
|-----------------------------|------------------------------|--------------------------------------|
| <input type="checkbox"/> No | <input type="checkbox"/> Yes | <input type="checkbox"/> Do Not Know |
|-----------------------------|------------------------------|--------------------------------------|

Will injury-illness result in lost workday(s)?

- | | | |
|-----------------------------|--|--------------------------------------|
| <input type="checkbox"/> No | <input type="checkbox"/> Yes, How Many? ____ | <input type="checkbox"/> Do Not Know |
|-----------------------------|--|--------------------------------------|

Section 4 - Incident Description

Description of incident:

What was person doing at time of incident?

Why did incident occur?

Was use or lack of safety equipment a factor in this incident?

If so, explain:

Were any safety regulations violated? _____ Explain:

Were any regulatory agencies notified? _____ Explain:

Action taken by regulatory agency:

Property damage? _____ Extent of damage:

Property owner: _____ Phone Number: _____

Address:

Space for Sketch or Additional Narrative

Section 5 – Incident Witnesses/Documentation

Incident Witnesses/Documentation

Incident Witness: _____

Phone Number: _____

Address:

Employer:

Statements Attached? No Yes

Were any photographs taken of the site after the incident? No Yes

Photographs taken by whom?

Photographs stored at: _____

Section 6 – Corrective Action/Recommendations

Recommended Corrective Action(s):

Completed by: _____
Date: _____

Note: For each incident or work-related injury/illness, this form must be completed and faxed/mailed to the distribution list above within 24 hr. In addition, for injuries and illnesses, an Employer's First Report of Injury Form, and an Employee's Claim for Worker's Compensation Benefits form must be completed within 24 hr and sent to Human Resources.

If a fatality occurs or three or more employees require in-patient hospitalization, the local OSHA office must be notified of the incident within 8 hr.

ATTACHMENT 2: PERSONAL ACKNOWLEDGMENT FORM

PERSONAL ACKNOWLEDGMENT FORM
HEALTH AND SAFETY PROGRAM
KIRTLAND AIR FORCE BASE, SITE TS4

STATEMENT OF UNDERSTANDING

Health and Safety Plan (HSP) Signature Page

Project personnel shall read the Project HSP and be familiar with its provisions. The signature below certifies that the individual has read, understood, and will comply with the guidelines set forth in the HSP and all Amendments contained within. I agree to abide by the requirements and will contact the Radiation Safety Officer, Mr. Terry Coggins, in the event I have any questions concerning this document.

SIGNATURE

John Ballard
Title, Company: _____
Date: _____

Chuck Hahn
Title, Company: _____
Date: _____

John C. Morgan
Title, Company: _____
Date: _____

Morris P. Fields
Title, Company: _____
Date: _____

Melissa G. Shettlemore
Title, Company: _____
Date: _____

Rebecca J. Manis
Title, Company: _____
Date: _____

ADDITIONAL SIGNATURES

Name: _____
Title, Company: _____
Date: _____

Name: _____
Title, Company: _____
Date: _____

Name: _____
Title, Company: _____
Date: _____

Name: _____
Title, Company: _____
Date: _____

Name: _____
Title, Company: _____
Date: _____

Name: _____
Title, Company: _____
Date: _____

ATTACHMENT 3: HAZARDOUS COMMUNICATION PROGRAM AND
EMPLOYEE GUIDE TO HAZARDOUS MATERIALS

Hazardous Communication Program

I. PURPOSE

The purpose of the OSHA Hazard Communication Standard is to establish uniform requirements to make sure that:

1. The hazards of all chemicals produced, imported, or used within the United States are evaluated, and
2. This hazard information is transmitted to affected employers and employees. Our first consideration in the performance of work is the protection of the safety and health of all employees. This Hazard Communication Program has been developed to ensure that employees receive adequate information about the possible hazards of hazardous substances used in the workplace.

II. DISCUSSION

A. APPLICABILITY

This program applies to chemicals known to be present in the workplace in such a manner that employees may be exposed under normal conditions of use or in a foreseeable emergency. The hazardous materials that are exempt include:

- Foods, drugs, and cosmetics intended for personal consumption while in the workplace.
- Consumer products packaged for distribution to, and use by, the general public. These materials must be used in the workplace in the same manner as normal consumer use and cannot result in a duration and frequency of exposure greater than exposures experienced by consumers.

B. FACILITIES

The majority of our facilities are "office" areas and would not be bound by the specific requirements of this program. However, many office products contain hazardous substances and are potential sources of employee chemical exposure. Care should always be exercised when using any hazardous material, even within an office setting.

Operations other than office areas may not be exempt from the provisions of the Hazard Communication Standard and therefore must strictly abide by the procedures set forth in this program. These include chemical use operations, such as the print shops, laboratories, graphic areas, research and development shops, hazardous waste sites, construction sites, water and wastewater treatment plants as well as work at industrial facilities.

Laboratories utilize numerous chemicals and hazardous materials that have been interpreted as falling under the provisions of the "Occupation Exposure to Hazardous Chemicals in Laboratories" regulation, which supersedes this program. For details, see the Laboratory Chemical Hygiene Plan.

Employees may be faced with greater potential exposure to hazardous materials while working on a client's facilities. All employees should understand that it is a Federal and State OSHA requirement that every employer using hazardous materials in the workplace have an effective hazard Communication Program or equivalent. A specific component of these programs is the responsibility of employers to provide information regarding their hazardous substances to contractors and guests.

When visiting a client's facility, employees should abide by the onsite health and safety procedures, become familiar with the site emergency procedures, and utilize Material Safety Data Sheets (MSDSs) to gain information on the hazardous materials present.

III. DEFINITIONS

At the end of this guide is a glossary of terms used frequently in the Hazard Communication Standard and on MSDSs. A few of the more commonly used terms are repeated here.

Carcinogen: A substance or agent capable of causing or producing cancer in humans or animals.

Designated representative: Any individual or organization to whom an employee gives written authorization to exercise a right of access to exposure and/or medical records.

Hazard Warning: Any words, pictures, symbols, or combination thereof appearing on a label or other appropriate form of warning which convey the health hazards and physical hazards of the substance(s) in the container(s).

Hazardous Substances: A hazardous substance is one for which scientifically valid evidence exists that it is a combustible liquid, compressed gas, explosive, flammable, organic peroxide, radioactive, oxidizer, pyrophoric, unstable (reactive), or water reactive.

Health hazards: A health hazard is a substance which is an irritant, skin hazard, toxic agent, highly toxic agent, corrosive material, eye hazard, agent that acts on the blood system, is a sensitizer, cancer-causing agent, reproductive toxin, liver toxin, kidney toxin, nervous system toxin, or agent that damages the skin, eyes, or mucous membranes. Health hazard effects can generally be classified as either acute (an immediate response to a short-term exposure) or chronic (from repeated exposure over a long period of time).

Material Safety Data Sheet (MSDS): A fact sheet summarizing information about material identification; hazardous ingredients; health, physical, and fire hazards; first aid; chemical reactivities and incompatibilities; spill, leak, and disposal procedures; and protective measures required for safe handling and storage. OSHA has established guidelines for descriptive data that should be concisely provided on a data sheet to serve as the basis for written hazard communication programs. The Chemical Manufacturer's Association developed a set of guidelines for a consistent MSDS format. This format has been accepted by the American National Standards Institute.

Physical hazard: A substance for which there is evidence that it is a combustible liquid, a compressed gas, explosive, flammable, an oxidizer, unstable (reactive), or water-reactive.

IV. PROCEDURE

A. HAZARD DETERMINATION

The Hazard Communication Standard requires that either chemical manufacturers, importers, or employers evaluate chemicals and determine if they are hazardous. We purchase materials from importers, distributors, or manufacturers for use "as-is", and do not produce our own chemical products. We meet the hazard determination requirement by relying on the analysis already performed by the manufacturers of the substances and do not reevaluate their hazards. Where necessary, we may perform independent analysis of mixtures of materials to determine if additional hazards exist.

The following are sources for lists of hazardous substances:

1. The Director's List of Hazardous Substances prepared by the Director of Industrial Relations for the State of California and similar lists produced by the Governor's office in State with OSHA-approved State Plans.
2. 29 Code of Federal Regulations 1910, Subpart Z, "Toxic and Hazardous Substances" (Occupational Safety and Health Administration).
3. "Threshold Limit Values for Chemical Substances in the Work Environment" by the American Conference of Governmental Industrial Hygienists (ACGIH).

B. CONTAINER LABELING

1. Original Manufacturer's Containers

Manufacturers, importers, and distributors of materials which we purchase must label, tag, or mark each container of hazardous substance(s) with the following information:

- Identity of the hazardous substance(s)
- Appropriate hazard warnings
- Name and address of the manufacturer, importer or other responsible party

No container of hazardous substances shall be released for use in the workplace unless the container is correctly labeled and the label is legible. Receiving departments, or person(s), must check all chemical containers (such as bags, drums, pails, etc.) to ensure that the label is intact, legible, written in English and has not been damaged in any way during shipment. Any containers with damaged labels must be kept separate and not used until they are re-labeled. A supply of new labels should be obtained from the manufacturer, importer, or distributor for this purpose.

2. Secondary Containers

Appropriate hazard warning labels must also be placed on secondary containers (i.e., containers used to store material dispensed from the manufacturer's original container). The secondary container must be labeled with either a copy of the manufacturer's label or a produced label that includes:

- Product identity
- Fire, physical and health hazards
- First Aid procedures
- Manufacturer's name

This label information can be obtained from the manufacturer's original container or the applicable MSDS. Business Units must ensure that all labels on secondary containers are clearly visible, legible, and include the required information. Whenever practical, Business Units are encouraged to order/purchase hazardous material in sizes that reduce/eliminate secondary container use.

3. Stationary Process Containers

A stationary process container is a fixed vessel or tank used to hold process chemicals. For example, a closed tank used to hold chemicals which are metered into continuous treatment processes, such as water treatment systems, is considered a stationary process container.

Appropriate hazard warning labels, signs, placards, process sheets, batch tickets, or operating procedures must be placed on or in the immediate area of all stationary process containers which contain hazardous materials. These must specify:

- Hazardous substance identity
- Hazard warnings (fire, physical, health)
- Emergency and first aid procedures
- Manufacturer's name (if applicable)

C. MATERIAL DATA SAFETY SHEETS

1. General

An MSDS explains the hazards associated with the use of a product and is a key source of hazard information for employees. Other than specifically exempt products, we are required to have available for employee and contractor/guest review the MSDSs for the hazardous materials utilized by employees. Business Units are responsible for surveying their area for all hazardous materials used and stored there and establishing a list of hazardous substances. Based on this inventory of hazardous substances, Business Units must maintain a current MSDS for each product.

To assist Business Units, our current practice is to require vendors to send MSDSs with each shipment of hazardous materials. When an MSDS does not accompany the shipment and no copy of the MSDS is available within the company, the shipment should be set aside in a controlled area until the MSDS is received.

2. Material Data Safety Sheet Binders

Copies of MSDSs are to be kept in an MSDS Binder that must be readily available to all department employees. The Business Unit Supervisor will be responsible for maintaining this binder and ensuring that it is properly maintained. The binder should be kept in a location that is readily accessible to employees during all shifts. If necessary, copies may also be placed in other locations to facilitate availability.

The MSDSs in the binder should generally be organized alphabetically by manufacturer and then product name. For example, methyl ethyl ketone (MEK) from Shell Oil Company would be found under "S" for Shell and then "M" within the Shell products.

The Business Unit's list of hazardous substances should serve as the table of contents for the MSDS binder. All items listed on the inventory should have a MSDS and every MSDS should correspond to an inventory item.

3. Material Safety Data Sheet Review

No materials will be introduced into the workplace until an MSDS has been received. Employees are required to receive information regarding the hazards of the materials they work with prior to actual usage.

The safety office will work with chemical users to review incoming MSDSs for completeness and any new and significant health and safety information. They will ensure that MSDSs are available to employees for every applicable product used and any new information is passed on to appropriate employees.

If an MSDS is not provided by the manufacturer, importer, or distributor, or if any of the required MSDS information is missing, the using Business Units will contact the appropriate party and request a complete MSDS. This request must be in writing, directed to the product manufacturer, importer, or distributor and be made within 7 working days of missing MSDS/information discovery.

4. New Information

Whenever new and significant health information is made known concerning a hazardous substance being used in the workplace, an updated MSDS must be requested from the manufacturer, importer, or distributor. This new information will be discussed with all affected employees (within 30 days of receipt) and the new MSDS placed into the Business Unit MSDS binder. Similarly, if the employer receives a new or revised MSDS the new information must be provided to employees within 30 days.

D. LIST OF HAZARDOUS SUBSTANCES

A list of hazardous substances used by a Business Unit is required to be placed or posted in an area that is readily accessible to affected employees. This list provides employees with their workplace hazardous substance inventory and shows which MSDSs are contained in the Business Unit's MSDS binder (it should also serve as the binder's table of contents). It is the Business Unit Supervisor's responsibility (with assistance from the safety office) to keep the list current.

One purpose of the Hazardous Substance List is to assist employees in finding the MSDS for hazardous substances used in the Business Unit. The list must identify the manufacturer and product identity. It should be organized alphabetically by manufacturer and then by product name. Catalog numbers, order numbers, or reference numbers can also be included on the list to facilitate product identification.

E. EMPLOYEE INFORMATION AND TRAINING

1. General

All employees included in this program who are exposed or potentially exposed to hazardous substances in their work must be provided Hazard Communication Information and training. Information and training will be given prior to initial work assignment and whenever a new hazard is introduced into their work area. In addition, those already trained must be periodically checked, retrained, and their compliance with applicable requirements enforced.

At a minimum, employees should receive Hazard Communication training/retraining to demonstrate knowledge of the following topics:

- An overview of the Hazard Communication Standard requirements, including employee rights.
- Information on any operation in their work areas where hazardous substances are present.
- The location and availability of the Written Hazard Communication Program, i.e., this policy/procedure and the Employee Guide to Hazardous Materials.
- The physical and health hazards of the hazardous substances in the work area.
- Methods and observation techniques for determining the presence or release of hazardous substances in the work place.
- How to lessen or prevent exposure to hazardous substances through controlled work practices, proper handling, and personal protective equipment.
- The steps the employer has taken to lessen or prevent exposure to these substances.
- Emergency and first aid procedures to follow if employees are exposed.
- How to read labels and review MSDSs to obtain appropriate hazard information.

2. Employee Rights

OSHA and the Hazard Communication Standard provides the following rights to every employee. All employees must be informed of these rights.

- Employees or their designated representative can receive all information regarding any hazardous substances they work with or are exposed to. This includes occupational monitoring results, exposure records, MSDSs, and medical records (medical records can be released to other individuals only when written permission is granted by the employee). Access must be provided within 15 days of a written request.
- Employees are protected from discharge or other discrimination for exercising any of their employee rights.
- Employees can refuse to work with a hazardous substance if the company cannot find out and communicate the hazards.

3. Documentation

All employee health and safety training (group, "tailgate", classroom, individual) must be thoroughly documented. Proper documentation includes the type of training conducted, date, attendees, instructor, and copies of handouts/material covered.

F. HAZARDOUS NON-ROUTINE TASKS

Employees may be required to perform non-routine tasks involving hazardous materials as part of their work. Prior to the start of such non-routine work, Business Unit Supervisors must provide each affected employee with information about hazards to which they may be exposed. This information will include:

- Specific hazard information
- Protective or safety measures which must be utilized

G. HAZARDOUS SUBSTANCES IN UNLABELED PIPES

Unlabeled pipes containing hazardous substances represent a serious safety concern for any employee working on these pipes. Prior to initiating any work on unlabeled pipes employees must be informed of the hazards of the materials contained within the pipes. Pipe diagrams and schematics are excellent sources of information and should be made readily available to employees.

Prior to starting work on unlabeled pipes, supervision must provide the following information to employees:

- The identity of the hazardous substance(s) within the pipes
- The potential hazards of those substances
- Safety precautions which must be taken

H. CONTRACTOR WORK

The Hazard Communication Standard requires that contractors be informed of the nature of hazardous substances to which their employees may be exposed while performing their work. In situations where contractor exposure to hazardous materials may occur, Business Unit Supervisors shall provide the following information prior to the beginning of the work:

- The identities of hazardous substances used by the contractor that the contractor's employees may be significantly exposed to while on the job site
- Location and access to applicable MSDSs
- Recommended precautions, protective measures, and emergency procedures

In addition, employees must be protected from the hazardous materials used by contractors. The Business Unit Supervisor, with assistance from the safety office, should review with contractors the hazardous materials that they are intending to utilize in performing their work. If necessary, Business Unit Supervisors should request MSDSs from the contractors.

I. PLAN ADMINISTRATION

This Hazard Communication Program will be monitored by the Health and Safety Manager who will be responsible for ensuring that all facets of the program are carried out and that the program is functioning effectively.

V. REFERENCES

- A. Title 20 Code of Federal Regulations 1910.1200, Hazard Communication.
- B. Genium Publishing Corporation. The MSDS Pocket Dictionary 2nd Edition, Schenectady, NY, 1994.

Employee Guide to Hazardous Materials

I. INTRODUCTION

As an employee, your duties may require you to work with substances which are potentially hazardous to your health. Training you to work safely with these hazardous substances is a critical step in providing a workplace that protects your health and safety. This guide was developed as part of the Hazard Communication Program and, together with training, will provide you with information on current regulations, health hazards, safety procedures, and emergency procedures associated with the with which hazardous substances you work.

Specifically, this guide will introduce and explain the requirements of two regulations which have been established by the Occupational Safety and Health Administration (OSHA). These regulations are known as "Access To Employee Exposure and Medical Records" (29 CFR 1910.1020) and the "Hazard Communication Standard" (29 CFR 1910.1200). (Note: Approved State OSHA plans have their own regulation corresponding to these Federal OSHA standards).

II. ACCESS TO EMPLOYEE EXPOSURE AND MEDICAL RECORDS

This regulation requires that an employer provide employees or their designated representative access to their own Exposure and Medical Records.

Employee Exposure Record includes any environmental and biological monitoring that has been taken to estimate your exposure to toxic substances or harmful physical agents.

The Employee Medical Record contains information concerning the health status of an Employee. Maintained by a physician or nurse, this record includes any medical history questionnaires, medical opinions, and diagnoses. It also contains descriptions of treatments, prescriptions, and employee complaints.

Written requests for these records should be directed to the Health & Safety manager.

III. INTRODUCTION TO TOXICOLOGY AND CHEMICAL HAZARDS

A. WHAT ARE HAZARDOUS SUBSTANCES?

Hazardous substances are chemicals which due to their toxic effects; physical properties like flammability, explosivity and reactivity; or potential to adversely affect the environment have been identified as requiring special precautions during their use. Very simply, they are materials that can cause you harm. The Hazard Communication Standard is specifically concerned with potential harm that these materials can cause to workers. The types and forms of hazardous substances you might find in your workplace are: acids, bases, solvents, dusts, fumes, mists, gases, fuels, smokes, and oils.

B. WHAT DOES THE TERM “TOXIC” MEAN?

While you may easily understand the hazard that a flammable liquid poses to you, the effects of a “toxic” exposure may be more complex. Simply stated, “toxic” means poisonous. However, you must understand that all chemicals, including common table salt and sugar, are toxic if consumed in large enough quantities. Therefore, you should look at the term “toxic” from the standpoint of how toxic is the substance, and how much has been absorbed by the body. For example, very little exposure to a highly toxic substance will cause you harm. For a less toxic substance, a much larger exposure would be necessary to cause harm.

C. WHAT ARE “EXPOSURE LIMITS”?

OSHA has reviewed medical and toxicological data on many hazardous substances. It has established airborne levels for many hazardous substances below which an average worker can safely work with the substance. These levels are called “**Permissible Exposure Limits (PELs)**.” An employer must reduce worker exposure below the PEL by using control measures.

There is another source of exposure limits which are not set by the government, but by a private organization called the ACGIH (American Conference of Governmental Industrial Hygienists). These levels are called **Threshold Limit Values (TLVs)**. They are not legal limits, but are guidelines for worker exposures to hazardous substances. Other factors discussed below are also important in understanding how hazardous substances may result in a toxic effect.

D. HOW DO HAZARDOUS SUBSTANCES ENTER THE BODY?

The three most common routes of entry for hazardous substances to enter your body are: 1) inhalation, 2) absorption, and 3) ingestion. **Inhalation:** Gases, vapors, mists, dusts, and fumes, when breathed in, can either harm the lungs directly or can be absorbed into the bloodstream and affect other organs, like the liver and kidneys. Because inhalation is the most common and potentially the most harmful type of exposure, nearly all PELs and TLVs refer to airborne levels of toxic substances.

Absorption: Some substances that come into contact with your skin or eyes can be absorbed into your bloodstream through your skin or if splashed in your eyes. The MSDS will indicate if skin absorption or direct skin injury may occur with a hazardous material.

Ingestion: Ingestion is not a common way that a hazardous substance enters your body. However, even small amounts of some highly toxic materials can be ingested and cause harm to you from bad personal hygiene practices (such as eating or smoking without first washing your hands).

E. WHAT ARE THE TYPES OF TOXIC EFFECTS?

Generally, there are two major types of toxic effects: acute and chronic. Acute effects can occur when your exposure to a chemical is large enough so that it affects you right away. Examples of acute toxicity are chemical skin burns, asphyxiation, and sudden poisoning.

Chronic effects can occur with repeated exposures after a long period of time. These effects may occur with fairly low-level exposures, so that the damage may not be obvious at first, but can eventually result in harm to you. The resulting injury may be slight (for example, skin irritation), or it may involve severe damage to organs and systems of your body (such as lung disease, cancer, or impaired reproductive function). Some hazardous chemicals have only acute or chronic effects, but some have both.

F. HAZARD GROUPS

It is important for you to understand the potential hazards of the substance with which you work so that you can help maintain a safe environment for yourself and your fellow workers. *Most hazardous substances can be used safely if you combine a basic understanding of the potential hazards with care, common sense, and appropriate control measures.*

Commonly used groups of these substances and their potential hazards are reviewed on the following pages.

1. Flammables

Substances that are easily ignited and which burn rapidly are called flammables. There are three factors that must exist to have a fire: fuel, oxidizer (supplies oxygen in a chemical reaction), and ignition source. The three components make up the fire triangle.

Flammable liquids are a common cause of fire in industry. A flammable liquid can form an ignitable mixture with air at room temperatures. The flammable liquid is the fuel, the air is the oxidizer, and the flame or spark, the ignition source.

2. Corrosives

Substances that can cause destruction or irreversible damage to human tissues are called corrosives. They may be liquid, solid, or gas, although they most commonly occur in the liquid state as acids or bases.

Corrosives are also defined in terms of pH. Strong acids, such as sulfuric acid and hydrochloric acid, usually have a pH less than 2. Strong bases, also referred to as caustics, such as ammonium hydroxide and potassium hydroxide, usually have a pH greater than 12. Pure water has a neutral pH of 7.

Corrosives are mainly damaging to the skin and eyes. Strong bases have a more corrosive effect on tissue than most strong acids. Bases are capable of dissolving skin fat, softening the skin layers, and sensitizing the skin to chemicals. Acids cause symptoms that resemble severe burns, such as redness, blistering, cracking, and rashes.

3. Irritants

Irritants are substances that may cause an inflammation when in contact with human tissue. Epoxy resin systems and organic solvents are two common examples. The area most commonly affected by irritants are the skin, eyes, and respiratory tract.

4. Sensitizers

Sensitizers do not always cause noticeable skin effects on first contact. They may cause unseen changes in the body's immune system, making the person allergic to future exposures to the same substance. Example of sensitizers are epoxy resins and hardeners, and phenolic plastics.

Photosensitizers are chemicals which sensitize the skin to sunlight so that the skin becomes sunburned unusually quickly. Coal tar pitch and crude petroleum are examples.

5. Asphyxiants

Asphyxiants are substances that deprive the body of oxygen, which must be transported from the lungs via the bloodstream to the cells. With complete deprivation of oxygen, brain cells perish in 4 to 6 minutes. If allowed to continue, oxygen deprivation may result in death. Asphyxiants are classified as either simple or chemical.

Simple asphyxiants are inert gases which displace the oxygen in the atmosphere to levels below that required for sufficient oxygen supply to body cells. Some common examples include carbon dioxide, ethane, helium, hydrogen, methane, and nitrogen.

Chemical asphyxiants are gasses that prevent the uptake of oxygen by the blood or interfere with oxygen transportation from the lungs to the tissues. Common examples include carbon monoxide, hydrogen cyanide, and hydrogen sulfide.

6. Cryogenics

Cryogenics are very cold liquids usually contained within pressurized cylinders. Among the most common are oxygen, nitrogen, natural gas, argon, helium, and hydrogen. Hazards associated with these materials include explosive atmospheres (where liquid natural gas or hydrogen is used), asphyxiation (where the cryogenic vapors have displaced the breathable air), and skin and eye hazards due to extremely low temperatures of these materials.

7. Carcinogens

Carcinogens are defined as substances which are capable of causing or producing cancer in humans or animals. The substances that induce cancer do so in a way that is still not understood. No one really knows why some substances are carcinogenic and others are not. We can be exposed to carcinogens not only

through the air we breathe and the water we drink, but also by our diet. Certain elements of our lifestyle, both on and off the job, may contribute to cancer.

OSHA lists carcinogens with which employers must use special precautions to prevent harmful exposure to workers. Exposures to these carcinogens is reduced by limiting their amount in solid or liquid mixture, using localized ventilation, providing employee training, using protective clothing, and prohibiting eating, drinking, and smoking in regulated areas.

8. Incompatibles

Certain materials will react violently when combined with each other. They are called incompatibles. Their reactions may produce fire, explosion, toxic gases, or tremendous heat. Some examples are:

Acids and Cyanides – the reaction between acids and cyanide salts gives off poisonous hydrogen cyanide gas. Many electroplating operations use both cyanide solutions and acid solutions. The two should never be mixed.

Acids and Bases – the reaction between strong acids and strong bases will give off large amounts of heat, often violently. Care must be taken not to mix the two.

Water Plus Strong Acids or Bases – strong acids and bases will also react by giving off large amounts of heat when mixed with water. When diluting strong solutions, always add the acid or base slowly to a large amount of water.

Oxidizers and Flammables – an oxidizer is an efficient source of oxygen which can keep a fire burning. It may be reactive enough to start a fire. Oxidizers sometimes supply enough heat to make fire extinguishers ineffective. Examples of oxidizers are nitric acid and potassium permanganate. (Flammable were discussed earlier).

REMEMBER, incompatible materials must be stored separately at all times to avoid hazardous reactions that can occur during spills, container leakages, fire, or earthquakes.

IV. THE HAZARD COMMUNICATION STANDARD – 29 CFR 1910.1200

A. PURPOSE OF THE HAZARD COMMUNICATION LAW

The purpose of this standard is to communicate to you and all employees the hazards of the materials with which you work. It is sometimes also called the “Employee Right-to-Know” law. This information is provided through the Hazard Communication Program which includes the following:

- Written Hazard Communication Program
- Hazardous Substances Listing and Inventory
- Material Safety Data Sheet Inventory
- Labeling and Hazard Warning System

- Employee Information and Training Program

B. SCOPE AND APPLICATION OF THE LAW

This law requires manufacturers or importers to find out the hazards of materials which they produce or import, then provide this information to employers by way of MSDSs (Material Safety Data Sheets). The employer is then required to supply the MSDS and other hazardous material information to employees. This law applies to any hazardous material which is in the workplace and used in a way that could cause exposure to employees under normal conditions of use or in an emergency.

V. MAJOR COMPONENTS OF HAZARD COMMUNICATION:

A. THE WRITTEN PROGRAM

- Details how the company is fulfilling all the requirements of the Hazard Communication Law.
- Is available upon request, to you and your designated representatives.

B. LIST OF HAZARDOUS SUBSTANCES

- The list must be posted in every work area.
- The list must also be in every department MSDS binder.
- The list itemizes the hazardous substances used in the Business Unit or specific work area.
- The list can be utilized as a reference to the MSDSs in the binder and for hazardous substances used.

C. HAZARDOUS SUBSTANCES TRAINING

- Is required for all employees exposed to hazardous substances.
- Informs you of the physical and health hazards of the substances which you work with, how you can protect yourself, and the requirements of the standard.
- Training will cover the general requirements, the details of the Hazard Communication Program, the location and availability of MSDSs, the list of hazardous substances, the written program, and other general hazardous substances information.
- Additional training will be given as needed on the specific health and physical hazards of substances with which you work.

D. CONTAINER LABELING

1. Original Manufacturer's Containers

- Manufacturers, importers and distributors of substances which are purchased must label, tag, or mark each container of hazardous substance(s) with the following information:
 1. Identity of the hazardous substance(s)
 2. Appropriate hazard warnings
 3. Name and address of the manufacturer, importer, or other responsible party
- No container of hazardous substances shall be released for use in the workplace unless the container is correctly labeled, and the label is legible.
- Any containers with damaged labels must be kept separate and not used until they are relabeled. A supply of new labels must be obtained from the manufacturer, importer, or distributor for this purpose.

2. Secondary Containers

- Appropriate hazard warning labels must also be placed on secondary containers (i.e., containers used to store material dispensed from the manufacturer's original container).
- The secondary container must be labeled with either a copy of the manufacturer's label or a department produced label that includes:
 1. Product identity
 2. Fire, physical and health hazards
 3. First Aid procedures
 4. Manufacturer's name
- This label information can be obtained from the manufacturer's original container or the applicable MSDS.
- Business Unit Supervisors must ensure that all labels on secondary containers are clearly visible, legible and include the required information.

E. MATERIAL SAFETY DATA SHEETS (MSDS)

1. MSDSs for every hazardous substance used in your work area should be in the plainly marked MSDS binder which is located in your Business Unit Supervisor's office. In some cases, there will be an MSDS binder in other work areas as well.
2. Each MSDS should contain the following information:

Source of the MSDS (manufacturer)

- The name, address, and emergency phone number of the preparer of the MSDS and the date of MSDS preparation.

Identity of the substance

- Common name
- Scientific or chemical name
- Trade name or abbreviation
- Chemical formula
- Chemical Abstract Service (CAS) number

List of hazardous ingredients

- Exception: Trade secrets don't need to be listed, but the information must be made available to safety and health professionals.

Physical and chemical characteristics

- Boiling point, specific gravity, vapor pressure, appearance and odor, etc.

Fire and explosion information

- Conditions which could result in a fire or explosion
- Appropriate fire extinguisher
- Approved fire fighting methods

Physical hazards

- Materials which are incompatible with the substance
- Any conditions to be avoided

Health hazards

- Signs and symptoms of overexposure
- Acute and chronic effects
- Routes of entry
- Medical conditions aggravated by exposure
- Listing as carcinogen or potential carcinogen
- Occupational exposure limits:
OSHA PELs
ACGIH TLVs

Special protection information

- Personal protective equipment to be used
- Safe handling requirements
- Engineering and administrative controls

Emergency and first aid procedures

Special precautions

- Special handling and storage requirements
- Spill and leak procedures

F. EMPLOYEE RIGHTS

OSHA, through the Hazard Communication standard, gives you the following rights:

- You can personally receive all information regarding any hazardous substances you work with or are exposed to.
- Your doctor or collective bargaining agent can receive information regarding any hazardous substances you work with or are exposed to.
- The company cannot discharge you or discriminate against you for exercising any of your rights under this law.
- You can refuse to work with a hazardous substance if the company cannot find out the hazards and communicate them to you.

VI. PREVENTING EMPLOYEE EXPOSURE

A. EMPLOYER MEASURES

Ways the company limits or prevents your exposure:

1. Engineering Controls

Ventilation systems and physical isolation of the chemical from the worker are examples of engineering controls. Engineering controls are the surest means of controlling your exposure to hazardous substances. They are also the most expensive and are sometimes not practical to install. Proper design and maintenance are important to keep them operating at maximum efficiency.

2. Administrative Controls

Substitution of less hazardous materials, providing rest periods, and rotating employees (where appropriate), are examples of reducing exposure through administrative controls. Business Unit Supervisors should use information provided in MSDSs to determine whether administrative controls can be used to further protect you from hazardous substances.

3. Personal Protective Equipment

Respirators and impervious gloves are examples of personal protective equipment (PPE). PPE reduces a worker's exposure to hazardous substances, but does not improve the overall workplace environment. Some PPE, like respirators, require special training and fitting to ensure proper protection as well as a medical examination.

B. EMPLOYEE RESPONSIBILITIES

1. Use safe work practices

Certain practices over which you have personal control (for example how fast a machine operates or how ingredients are added to a mixing vessel) can significantly affect your exposure. You should be carefully trained to recognize this fact and always work according to prescribed procedures.

2. Personal hygiene

Measures as simple as washing your hands before eating, or smoking, or showering at the end of a work shift can significantly reduce your exposure to hazardous substances. Personal hygiene is particularly important when handling highly toxic substances. OSHA regulations for certain substances (like lead) require specific personal hygiene practices.

3. Read and follow label warnings

Labeling (as required by the Hazard Communication Law) can be an important control measure if workers read, understand, and follow label instruction. If you see the words: "danger", "warning", or "caution", make sure you read the label carefully and refer to the MSDS for more information.

C. DETECTING HAZARDOUS SUBSTANCES

The following methods or reactions can be used to help you detect the presence of, release of, or exposure to hazardous substances.

1. Air Sampling

Industrial hygienists are trained to use a variety of sampling equipment which is designed to detect mists, vapors, dust or fumes in the air.

2. Visual Appearance

Some hazardous substances will form colored "clouds" or stain surfaces which they contact.

3. Odor

In some cases a hazardous substance will have a particular odor and be easily detected, e.g. ammonia. Although many hazardous substances will not have any odor at all, e.g. carbon monoxide.

4. Dizziness/Headache

Some hazardous substances will cause headache and dizziness when you are exposed.

5. Skin/Eye/Throat Irritation

Many hazardous substances will cause irritation of the eyes, skin, and/or throat if you are exposed.

It is very important that you understand the health hazards and other properties of the hazardous substances you work with in an effort to predict, prevent, or detect potentially hazardous releases or exposures. Many hazardous substances will cause irritation of the eyes, skin and/or throat if you are exposed.

Glossary

Acute effect – an adverse effect, usually as a result of short term but high-level exposure.

ACGIH – American Conference of Governmental Industrial Hygienists. ACGIH publishes recommended occupational exposure limits for hundreds of chemical substances and physical agents.

Carcinogen – a substance or agent capable of causing or producing cancer in humans or animals.

Chronic effect – an adverse effect with symptoms that develop over a long period of time or which recur frequently. This effect is usually a result of a long-term exposure.

Combustible substance – any substance which after ignition will continue to burn in air.

Designated representative – any individual or organization to whom an employee gives written authorization to exercise a right of access to exposure and/or medical records.

DOT – Department of Transportation.

Emergency – any potential occurrence such as, but not limited to, equipment failure, rupture of containers, or failure of control equipment, which may or does result in a release of a hazardous substance into the workplace.

Exposure or Exposed – any situation arising from work operation where an employee may ingest, inhale, absorb through the skin or eyes, or otherwise come into contact with a hazardous substance.

Flammable liquids – liquids with a flash point below 100° F.

Flash point – the minimum temperature at which a liquid gives off vapor at sufficient concentrations to form an ignitable mixture with air.

Fumes – small, solids particles usually created by heating metals above their melting point.

General exhaust ventilation - provides air circulation throughout a room or building by natural infiltration of air or with an air-moving device.

Hazard – possibility that exposure to a material will cause injury or harm when used under certain conditions.

Hazard warning – any words, pictures, symbols or combination thereof appearing on a label or other appropriate form of warning which convey the health hazards and physical hazards of the substance(s) in the container(s).

Hazardous substance – any substance which is a physical hazard or a health hazard. In a broad sense, any substance with properties capable of producing adverse effects on the safety or health of a human being.

Health hazard – a substance for which there is evidence that acute or chronic health effects may occur in exposed employees. The term “health hazard” includes substances which are carcinogens, toxic agents, irritants, corrosives, sensitizers, and agents which damage the lungs, skin, eyes, or mucous membranes.

Ingestion – the swallowing of substances.

Inhalation – the breathing in of a gas, mist, fume, vapor, or dust.

Label – any written, printed, or graphic material displayed on or affixed to containers of hazardous substances.

LC – lethal concentration; a concentration of a substance that is fatal for a test animal.

LD – lethal dose; a dose, usually in grams or milligrams, that is fatal for a test animal.

LD50 – lethal dose – 50; a dose at which 50 percent of a population of the same species will die within a specified time.

LEL – lower explosive limit; the lowest concentration of a substance that will produce an explosion when an ignition source is present.

Local exhaust ventilation – captures and removes the contaminant being controlled at or near the place where it is created or dispersed.

Local health effect – damage which occurs where the chemical makes initial contact with the body.

Material Safety Data Sheet (MSDS) – A fact sheet summarizing information about material identification; hazardous ingredients; health; physical; and fire hazards; first aid; chemical reactivities and incompatibilities; spill, leak and disposal procedures; and protective measures required for safe handling and storage. OSHA has established guidelines for descriptive data that should be concisely provided on a data sheet to serve as the basis for written hazard communication programs. The Chemical Manufacturer’s Association developed a set of guidelines for a consistent MSDS format. This format has been accepted by the American National Standards Institute.

Organic – chemicals that contain carbon.

OSHA – Occupational Safety and Health Administration. Part of the U.S. Department of Labor.

Oxygen deficiency – an atmosphere with less than the percentage of oxygen found in normal air. OSHA defines an oxygen deficient atmosphere as having less than 19.5 percent oxygen.

Particulate – solid substance which may be suspended in air.

PEL – permissible exposure limit; an exposure level set by OSHA which may either be a time-weighted average (TWA) or a short-term exposure limit (STEL).

pH – a scale from 0 to 14 which is used to measure the strength of acids and bases, with neutrality indicated at 7. Acids have a pH less than 7 and bases have a pH greater than 7.

Physical hazard – a substance for which there is evidence that it is a combustible liquid, a compressed gas, explosive, flammable, an oxidizer, unstable (reactive) or water-reactive.

ppm – parts per million; a unit for measuring the concentration of a gas, vapor, or other contaminant in the air. This is a measure of the parts of gas, vapor, or other contaminant per million parts of air.

Polymerization – a chemical reaction in which small molecules combine to form larger molecules. This becomes a hazard when a large amount of energy is released during the process.

Sensitizer – a substance that may cause some individuals to develop an allergic reaction after extended or repeated exposure.

Stability – the ability of a material to remain unchanged.

Systemic health effect – damage which occurs when a chemical is absorbed and travels through the body to a specific organ.

TLV – threshold limit value; an estimate of the chemical levels, in parts per million or milligrams per cubic meter of air, that most people can be exposed to without adverse effects. TLVs are recommendations established by the American Conference of Governmental Industrial Hygienists and are used only as guidelines.

TLV-ceiling – the concentration which should not be exceeded, even for an instant.

TLV-STEL – short-term exposure level; the maximum concentration to which workers can be exposed for a period of up to 15 minutes.

TLV-TWA – the allowable time-weighted average concentration for a normal 8-hour workday or 40 hour workweek.

Toxic material – a substance which produces injury or illness if it is ingested, inhaled, or absorbed.

Toxicity – the capacity of a substance to produce an unwanted effect.

UEL – upper explosive limit; the highest concentration of a substance that will produce an explosion when an ignition source is present.

Unstable – the tendency of a material to decompose or change chemically during normal handling or storage.

Vapors – the gaseous form of substances, which are normally in the solid or liquid state at room temperature and pressure.

Appendix B

Subsurface Characterization Results

Soil Sample Location 1
 Northing 3877176.90
 Easting 359954.96
 Elevation 1639.82

Core #	Core Section	900's Gamma Activity pCi/g	Depth inches ¹
1	a	1	-3
	b	0.5	-9
	c	1.5	-15
2	a	0.6	-27
	b	0.1	-33
	c	2.3	-39
	d	0.8	-42
3	a	2.1	-51
	b	0.9	-57
	c	2.1	-61.5
4	a	1.1	-75
	b	0.7	-81
	c	0 *	-82.25
5	a	1.4	-99
	b	1.8	-105
	c	1.6	-111

Note: An asterisk indicates a subsurface sample with an elevated level of thorium activity attributed to surface soil accumulating in the first segment of a subsequent 0.6-m (2-ft) sampling event.

¹ One inch equals 2.54 centimeters.

Soil Sample Location 2
 Northing 3877147.43
 Easting 359936.87
 Elevation 1639.03

Core #	Core Section	900's Gamma Activity pCi/g	Depth inches
1	a	1.7	-3
	b	1	-9
2	a	1.4	-27
	b	1.7	-33
	c	1.1	-34.75
3	a	0.9	-51
	b	1.9	-57
	c	0.9	-60.5
4	a	1	-75
	b	1.6	-81
	c	1.7	-87
5	a	1.8	-99
	b	1.3	-105
	c	2	-111
	d	1.1	-114

Soil Sample Location 3
 Northing 3877169.15
 Easting 359959.30
 Elevation 1639.84

Core #	Core Section	900's Gamma Activity pCi/g	Depth inches
1	a	0.9	-3
	b	1.5	-9
	c	1.8	-12.5
2	a	1.6	-27
	b	1.2	-33
	c	1.7	-38.375
3	a	1	-51
	b	1.1	-56.75
4	a	0.7	-75
	b	0.4	-80.5
5	a	0.8	-99
	b	1.1	-105
	c	0.1	-108.75

Soil Sample Location 4
 Northing 3877166.48
 Easting 359990.19
 Elevation 1639.71

Core #	Core Section	900's Gamma Activity pCi/g	Depth inches
1	a	0.2	-3
	b	1.2	-9
	c	0.3	-13.75
2	a	2	-27
	b	1.5	-33
3	a	0.7	-51
	b	1.5	-57
	c	2.5	-63
	d	1.8	-65
4	a	0.9	-75
	b	1.4	-81
	c	0.1	-87
	d	0.9	-88.75
5	a	0.6	-99
	b	1.2	-105
	c	1.1	-111
	d	1.3	-112.5

Soil Sample Location 5
 Northing 3877162.55
 Easting 360038.63
 Elevation 1639.60

Core #	Core Section	900's Gamma Activity pCi/g	Depth inches
1	a	1.4	-3
	b	1.1	-9
	c	1.5	-15
2	a	2.3	-27
	b	0.1	-33
	c	0	-39
3	a	1.3	-51
	b	1.4	-57
	c	1.2	-63
	d	1.8	-64.25
4	a	0.2	-75
	b	0.9	-81
	c	1	-87
	d	0.8	-89
5	a	0.9	-99
	b	1.8	-105
	c	1.6	-111
	d	0.3	-112

Soil Sample Location 6
 Northing 3877000.63
 Easting 360053.55
 Elevation 1638.81

Core #	Core Section	900's Gamma Activity pCi/g	Depth inches
1	a	0.3	-3
	b	0.7	-9
	c	1.6	-14.5
2	a	1.3	-27
	b	0.6	-33
	c	0.9	-38.25
3	a	** 2.3	-51
	b	1.5	-57
	c	0.6	-63
	d	0.9	-64.75
4	b	*** 0.9	-81
	c	1.4	-85.5
5	a	0.4	-99
	b	1.4	-105
	c	0.3	-111
	d	1.8	-113.25

Soil Sample Location 7
 Northing 3876907.67
 Easting 360016.91
 Elevation 1638.19

Core #	Core Section	900's Gamma Activity pCi/g	Depth inches
1	a	1.7	-3
	b	2.4	-9
	c	1.1	-11.5
2	a	1.1	-27
	b	1.9	-33
	c	1.1	-36.75
3	a	1.8	-51
	b	1	-57
	c	0.1	-63
	d	0.2	-66
4	a	0.6	-75
	b	0	-76.75
5	a	2.2	-99
	b	0.7	-105
	c	3	-105.75

Soil Sample Location 8
 Northing 3876902.90
 Easting 359939.70
 Elevation 1638.32

Core #	Core Section	900's Gamma Activity pCi/g	Depth inches
1	a	1	-3
	b	0.7	-9
	c	2.1	-13
2	a	0.9	-27
	b	1.5	-32
3	a	0.9	-51
	b	0.3	-57
	c	2.2	-63
	d	0.7	-64
4	a	1.7	-75
	b	1.3	-81
	c	0.3	-87
	d	1.7	-89.25
5	a	1.6	-99
	b	1.7	-105
	c	1.7	-106.5

Soil Sample Location 9
 Northing 3876921.99
 Easting 359858.35
 Elevation 1638.22

Core #	Core Section	900's Gamma Activity pCi/g	Depth inches
1	a	1.9	-3
	b	0.9	-9
	c	1.4	-12.5
2	b	*** 1.6	-33
	c	0.1	-39
	d	2	-40
3	a	0.6	-51
	b	1.8	-57
	c	** 0	-63
4	a	1.1	-75
	b	1.2	-81
	c	0.9	-86.25
5	a	0.1	-99
	b	1.9	-105
	c	1.1	-110.5

Soil Sample Location 10
 Northing 3876986.87
 Easting 359812.40
 Elevation 1638.32

Core #	Core Section	900's Gamma Activity pCi/g	Depth inches
1	a	1.8	-3
	b	1.2	-9
	c	0.4	-12.5
2	a	0.2	-27
	b	0.4	-33
	c	0.9	-35.5
3	a	0.9	-51
	b	1.1	-57
	c	0.1	-62.5
4	a	1.3	-75
	b	1.1	-81
	c	0.4	-85.25
5	a	0.7	-99
	b	1.7	-105
	c	0.3	-111
	d	0.6	-113.5

Soil Sample Location 11
 Northing 3876987.99
 Easting 359807.84
 Elevation 1638.34

Core #	Core Section	900's Gamma Activity pCi/g	Depth inches
1	a	1.6	-3
	b	1.6	-9
	c	1.9	-14.75
2	a	0.3	-27
	b	0.1	-33
	c	2.1	-36.25
3	a	1.9	-51
	b	3.3	-57
	c	1.6	-58
4	a	0.1	-75
	b	1.5	-81
	c	1.2	-86.25

Soil Sample Location 12
 Northing 3876988.61
 Easting 359804.65
 Elevation 1638.21

Core #	Core Section	900's Gamma Activity pCi/g	Depth inches
1	a	2.2	-3
	b	1.2	-9
	c	1.3	-15
2	a	0.5	-27
	b	1.6	-33
	c	0.2	-35
3	a	2	-51
	b	1.6	-57
	c	1.6	-63
	d	2.2	-66
4	a	1.1	-75
	b	1.5	-81
	c	1	-82.5

Soil Sample Location 13
 Northing 3876989.16
 Easting 359800.24
 Elevation 1638.18

Core #	Core Section	900's Gamma Activity pCi/g	Depth inches
1	a	1.1	-3
	b	0.7	-9
	c	0.6	-15
2	a	0.9	-27
	b	1.8	-33
3	a	1.6	-51
	b	0	-54.75
4	a	1.5	-75
	b	1.5	-81
	c	1	-86.5

Soil Sample Location 14
 Northing 3876985.09
 Easting 359801.38
 Elevation 1638.33

Core #	Core Section	900's Gamma Activity pCi/g	Depth inches
1	a	1.7	-3
	b	1	-9
	c	0 *	-13.25
2	a	1.4	-27
	b	0.9	-33
	c	0.8	-35.5
3	a	1	-51
	b	2	-57
4	a	0.9	-75
	b	0.6	-81
	c	1.2	-83.25

Soil Sample Location 15
 Northing 3876981.278
 Easting 359797.55
 Elevation 1638.298

Core #	Core Section	900's Gamma Activity pCi/g	Depth inches
1	a	1.1	-3
	b	0.7	-9
	c	0.8	-13.75
2	a	0 *	-27
	b	1.1	-33
	c	0 *	-37.25
3	a	1.6	-51
	b	2.9	-57
	c	2.5	-58.75
4	a	1.6	-75
	b	0.9	-81
	c	0 *	-83.75

Soil Sample Location 16
 Northing 3877048.887
 Easting 359873.453
 Elevation 1639.099

Core #	Core Section	900's Gamma Activity pCi/g	Depth inches
Core 1	a	2.2	-3
	b	3.3	-9
	c	2.7	-13.5
Core 2	a	2.5	-27
	b	3.3	-33
	c	3.8	-35.5
Core 3	a	2.2	-51
	b	3.2	-57
Core 4	a	3.4	-75
	b	2.4	-81
	c	0.8	-84.25

Soil Sample Location 17
 Northing 3877149.528
 Easting 360037.753
 Elevation 1639.508

Core #	Core Section	900's Gamma Activity pCi/g	Depth inches
1	a	1.2	-3
	b	2.2	-9
	c	2	-13.25
2	a	1.2	-27
	b	1.8	-33
	c	*	0 -38.75
3	a	2	-51
	b	1.8	-57
	c	0.6	-63
	d	2.6	-66.5
4	a	1.4	-75
	b	1.5	-81
	c	1.9	-87
5	a	*	0 -99
	b	1.6	-105
	c	1	-111
	d	*	0 -114.5

Soil Sample Location 18
 Northing 3877112.248
 Easting 360042.034
 Elevation 1639.41

Core #	Core Section	900's Gamma Activity pCi/g	Depth inches
1	a	2	-3
	b	3.2	-9
	c	0.8	-11.5
2	a	1.6	-27
	b	2.2	-33
	c	2.1	-36
3	a	2.4	-51
	b	0 *	-57
	c	2.8	-63
4	a	2.6	-75
	b	1.9	-81
	c	2.6	-87
5	a	3.1	-99
	b	1.8	-105
	c	2.7	-109

Soil Sample Location 19
 Northing 3876920.656
 Easting 360038.147
 Elevation 1638.139

Core #	Core Section	900's Gamma Activity pCi/g	Depth inches
1	a	2.3	-3
	b	1.9	-9
	c	0.3	-12.25
2	a	2.8	-27
	b	2.2	-33
	c	2.5	-39
	d	1.5	-42.75
3	a	2.6	-51
	b	1.5	-57
	c	3.4	-63
	d	2.2	-66.75
4	a	2.3	-75
	b	1.9	-81
	c	2.7	-84.75
5	a	2.4	-99
	b	2.2	-105
	c	2.7	-111

Soil Sample Location 20
 Northing 3876914.184
 Easting 359956.536
 Elevation 1638.306

Core #	Core Section	900's Gamma Activity pCi/g	Depth inches
1	a	1.1	-3
	b	3.1	-9
	c	1.3	-11
2	a	2.3	-27
	b	1.5	-33
	c	2.8	-37
3	a	1.5	-51
	b	2.4	-57
	c	0.4	-63
4	a	4.5	-75
	b	4.4	-81
	c	2.6	-83
5	a	3.1	-99
	b	2.7	-105
	c	0.1	-107.5

Soil Sample Location 21
 Northing 3876911.037
 Easting 359882.633
 Elevation 1638.35

Core #	Core Section	900's Gamma Activity pCi/g	Depth inches
1	a	1.2	-3
	b	2	-9
	c	1.7	-12.5
2	a	1.5	-27
	b	3.2	-33
	c	3.3	-39
3	d	3	-42.75
	a	3.8	-51
	b	2	-57
	c	1.4	-63
4	d	0.4	-66.5
	a	0.5	-75
	b	1.2	-81
	c	2.1	-86
5	a	2.6	-99
	b	1.7	-105
	c	0.8	-111
	d	1.3	-114.5

Soil Sample Location 22
 Northing 3876983.81
 Easting 359818.25
 Elevation 1638.43

Core #	Core Section	900's Gamma Activity pCi/g	Depth inches
1	a	0.3	-3
	b	0.3	-9
	c	2.6	-12.75
2	a	3.1	-27
	b	0.8	-33
	c	1.9	-40
3	c	2.3	-63
	d	1.5	-65
4	a	0.1	-75
	b	0.5	-81
	c	0	-87
5	d	0	-90.75
	a	1.7	-99
	b	3.7	-105
	c	2.7	-110.75

Soil Sample Location 23
 Northing 3877011.622
 Easting 359841.762
 Elevation 1638.518

Core #	Core Section	900's Gamma Activity pCi/g	Depth inches
1	a	5	-3
	b	2.2	-9
	c	3.6	-14.5
2	a	2.7	-27
	b	0.8	-33
	c	1.8	-39
3	d	1.2	-42.75
	a	3.2	-51
	b	2.8	-57
4	c	3.7	-60.5
	a	2.2	-75
	b	2.3	-81
5	c	0.4	-86
	a	1.4	-99
	b	3.8	-105
	c	0.4	-111
	d	0.1	-114.75

Soil Sample Location 24
 Northing 3877056.939
 Easting 359885.077
 Elevation 1638.658

Core #	Core Segment	900's Gamma Activity PCi/g	Depth inches
1	a	2	-3
	b	0 *	-9
	c	0.4	-14.375
2	a	2.4	-27
	b	2.2	-33
3	a	2.4	-50.75
4	a	2.9	-75
	b	2.4	-81
	c	1.8	-85.25
5	a	0 *	-99
	b	3.4	-105
	c	1.5	-111
	d	3.3	-114.75

Soil Sample Location 25
 Northing 3876982.113
 Easting 359831.134
 Elevation 1638.524

Core #	Core Segment	900's Gamma Activity PCi/g	Depth inches
1	a	2.5	-3
	b	1.1	-9
	c	0.8	-12.5
2	a	0.1	-27
	b	3.6	-33
	c	0.1	-39
	d	1.3	-42.75
3	a	2.9	-51
	b	2.1	-57
	c	1.4	-59.75
4	a	4.8	-75
	b	2.3	-81
	c	4.2	-85.5
5	a	1.6	-99
	b	2.3	-104.75

Soil Sample Location 26
 Northing 3876989.006
 Easting 359875.426
 Elevation 1638.799

Core #	Core Segment	900's Gamma Activity pCi/g	Depth inches
1	a	3.3	-3
	b	4.7	-9
	c	0 *	-12.5
2	a	4.3	-27
	b	3.9	-33
	c	0.2	-38
3	a	2.3	-51
	b	0.8	-57
	c	2.5	-61.5
4	a	1.3	-75
	b	0.6	-79
5	b	0.2 ***	-105
	c	1.6	-107

Soil Sample Location 27
 Northing 3876990.018
 Easting 359892.303
 Elevation 1638.779

Core #	Core Segment	900's Gamma Activity pCi/g	Depth inches
1	a	9.5	-3
	b	3.4	-9
	c	0.5	-13.25
2	a	4.9	-27
	b	4	-33
	c	0.7	-38.75
3	a	2.9 **	-51
	b	0.1	-57
	c	0.3	-61.5
4	a	1.8	-75
	b	3.4	-81
	c	2.9	-83.5
5	a	3.1	-99
	b	5	-105
	c	4.1	-110

Soil Sample Location 28
 Northing 3876992.039
 Easting 359904.267
 Elevation 1638.834

Core #	Core Segment	900's Gamma Activity pCi/g	Depth inches
1	a	55.3	-3
	b	8.6	-9
	c	4.7	-12.5
2	a	4.8	-27
	b	0.9	-33
	c	4.7	-38
3	a	0.7	-51
	b	1.6	-57
	c	1.8	-59.75
4	a	3.1	-75
	b	2.6	-81
	c	4	-82.25
5	a	3.4	-99
	b	2.1	-105
	c	3.5	-107.25

Soil Sample Location 29
 Northing 3876996.688
 Easting 359938.529
 Elevation 1638.718

Core #	Core Segment	900's Gamma Activity pCi/g	Depth inches
1	a	22.9	-3
	b	19.6	-9
	c	15.1	-14.5
2	a	** 19.6	-27
	b	14.1	-33
	c	6.6	-38.5
3	b	*** 5.6	-57
	c	4.2	-62.375
4	b	*** 5.2	-81
	c	2	-85
	a	1.7	-99
5	b	2.9	-105
	c	1.5	-107.5

Soil Sample		Location 30	
	Northing	3876985.491	
	Easting	359947.012	
	Elevation	1638.645	
		900's	
		Gamma	
Core #	Core Segment	Activity pCi/g	Depth inches
1	a	15.2	-3
	b	5	-9
	c	3.3	-11.75
2	a	3.1	-27
	b	2.8	-33
	c	2.9	-39
3	b	***	-57
	c	3.2	-61.625
4	b	***	-81
	c	2.5	-85.375

Soil Sample		Location 31	
	Northing	3876988.26	
	Easting	359941.847	
	Elevation	1638.672	
		900's	
		Gamma	
Core #	Core Segment	Activity pCi/g	Depth inches
1	a	32.1	-3
	b	29	-9
	c	11.7	-14
2	a	18	-27
	b	*	-33
	c	1.9	-39
3	b	***	-57
	c	3.4	-62.5
4	b	***2	-81
	c	3.6	-87
5	a	3.2	-99
	b	2.3	-105
	c	2.8	-110.5

Soil Sample Location 32
 Northing 3876991.344
 Easting 359934.755
 Elevation 1638.676

Core #	Core Segment	900's Gamma Activity pCi/g	Depth inches
1	a	40.6	-3
	b	10	-9
	c	6.9	-13
2	b	*** 6.8	-33
	c	0.6	-35.5
3	a	** 8	-51
	b	3	-57
	c	1.5	-62.5
4	b	*** 1.2	-81
	c	2	-86.5

Soil Sample Location 33
 Northing 3877001.342
 Easting 359936.771
 Elevation 1638.752

Core #	Core Segment	900's Gamma Activity pCi/g	Depth inches
1	a	15.7	-3
	b	5.7	-9
	c	4.5	-13
2	b	*** 3.2	-33
	c	1	-36.25
3	b	*** 1.8	-57
	c	0.8	-64.25
4	b	*** 0.4	-81
	c	2.1	-87

Appendix C

Isco Sampling Program

Isco Program

After unit is turned on, the main Menu will appear, and, in a few seconds, a second Menu will be displayed.

Choose option "PROGRAM"

The Program Name Window will appear

Choose "YES" to change name, if desired

Next Window will show "SITE DESCRIPTION – CHANGE?"

Select Option

Next Window: "Select Units for Length" (for the intake line)

Select Option

Next Window: "Select Units For Flow Volume"

Select Option

Window: "PROGRAM MODULE?"

Select "NO"

WINDOW: "NUMBER OF BOTTLES:"

Select TOTAL number of bottles to be utilized (in this case, 24)

WINDOW: "BOTTLE VOLUME"

Enter Volume (in this case, 1 liter)

WINDOW: "SUCTION LINE LENGTH"

Enter Length (in this case, 25 feet)

WINDOW: "AUTO SUCTION HEAD- ENTER HEAD"

Select AUTO SUCTION HEAD

WINDOW: "RINSE CYCLES"

Enter 0

WINDOW: "Retry UP to 0 TIMES WHEN SAMPLING"

Enter 0

WINDOW: "ONE PART PROGRAM- TWO PART PROGRAM"

Select TWO PART PROGRAM

WINDOW: "24 BOTTLES AVAILABLE-ASSIGN BOTTLE 1 THRU_ TO PART A"

Select 1-12

WINDOW: "UNIFORM Paced, FLOW PACED, etc."

Select FLOW PACED

WINDOW: "TIME BETWEEN SAMPLE EVENTS"

Select 0,0

WINDOW: "_ BOTTLES PER SAMPLE EVENT"

Select 1

WINDOW: "SWITCH BOTTLES EVERY _ SAMPLES"

Select 1

WINDOW: "RUN CONTINUOUSLY?"

Select "NO"

WINDOW: "DO YOU WANT SAMPLES VOLUMES DEPENDENT ON FLOW?"

Select NO

WINDOW: "SAMPLE VOLUME"

Enter Volume (in this case, 1 liter)

Part 2 of program:

WINDOW: "ENABLE"

Select RAIN

WINDOW: "ENABLE RAIN AND"

Select AND

WINDOW: "ENABLE RAIN and "

Select LEVEL

WINDOW: "RAIN - SET POINT"

ENTER DATA (in this case, 0.05 inches per 15 minutes)

WINDOW: "ENABLE WHEN:"

Select "ABOVE SET POINT"

WINDOW: "RESET RAIN HISTORY"

Select "NO"

WINDOW: "ONCE ENABLED - STAY ENABLED"

Select "NO"

WINDOW: "SAMPLE AT ENABLE"

Select "YES"

WINDOW: "PAUSE _ RESUME"

Select "DONE"

WINDOW: "UNIFORM TIME PACED< FLOW PACED, etc."

Select "FLOW PACED"

WINDOW: "PACED BY:"

Select "FLOW PULSES"

WINDOW: "NUMBER OF PULSES _ (or similar statement)

Select Value (usually 3)

WINDOW" "SAMPLE AT START"

Select "NO"

WINDOW: " _ BOTTLE PER SAMPLE EVENT (1-18)"

Enter 1

WINDOW: "SWITCH BOTTLES ON..."

Select "NUMBER OF SAMPLES"

WINDOW: "SWITCH BOTTLES EVERY - SAMPLES"

ENTER 1

WINDOW: "RUN CONTINUOUSLY"

ENTER "NO"

WINDOW: "SAMPLE VOLUME"

Enter VOLUME (in this case, 1 liter)

WINDOW: "ENABLE"

Select "NONE"

WINDOW: "SAMPLE AT DISABLE"

Select "YES"

WINDOW: "NO DELAY TO START< DELAYED START, etc."

Select "NO DELAY TO START"

WINDOW: "PROGRAMMING COMPLETE RUN THIS PROGRAM ..."

Select "YES"

