

AD_____

Award Number: DAMD17-03-1-0028

TITLE: EGR1 Target Genes that Regulate Growth/Survival of
Prostate Cells

PRINCIPAL INVESTIGATOR: Jianxiu Yu, Ph.D.

CONTRACTING ORGANIZATION: The Burnham Institute
La Jolla, California 92037-1005

REPORT DATE: March 2004

TYPE OF REPORT: Annual Summary

PREPARED FOR: U.S. Army Medical Research and Materiel Command
Fort Detrick, Maryland 21702-5012

DISTRIBUTION STATEMENT: Approved for Public Release;
Distribution Unlimited

The views, opinions and/or findings contained in this report are those of the author(s) and should not be construed as an official Department of the Army position, policy or decision unless so designated by other documentation.

BEST AVAILABLE COPY

20040907 006

REPORT DOCUMENTATION PAGE

Form Approved
OMB No. 074-0188

Public reporting burden for this collection of information is estimated to average 1 hour per response, including the time for reviewing instructions, searching existing data sources, gathering and maintaining the data needed, and completing and reviewing this collection of information. Send comments regarding this burden estimate or any other aspect of this collection of information, including suggestions for reducing this burden to Washington Headquarters Services, Directorate for Information Operations and Reports, 1215 Jefferson Davis Highway, Suite 1204, Arlington, VA 22202-4302, and to the Office of Management and Budget, Paperwork Reduction Project (0704-0188), Washington, DC 20503

1. AGENCY USE ONLY (Leave blank)	2. REPORT DATE March 2004	3. REPORT TYPE AND DATES COVERED Annual Summary (1 Mar 2003 - 28 Feb 2004)	
4. TITLE AND SUBTITLE EGR1 Target Genes that Regulate Growth/Survival of Prostate Cells		5. FUNDING NUMBERS DAMD17-03-1-0028	
6. AUTHOR(S) Jianxiu Yu, Ph.D.			
7. PERFORMING ORGANIZATION NAME(S) AND ADDRESS(ES) The Burnham Institute La Jolla, California 92037-1005 <i>E-Mail:</i> jyu@burnham.org		8. PERFORMING ORGANIZATION REPORT NUMBER	
9. SPONSORING / MONITORING AGENCY NAME(S) AND ADDRESS(ES) U.S. Army Medical Research and Materiel Command Fort Detrick, Maryland 21702-5012		10. SPONSORING / MONITORING AGENCY REPORT NUMBER	
11. SUPPLEMENTARY NOTES Original contains color plates: All DTIC reproductions in black and white.			
12a. DISTRIBUTION / AVAILABILITY STATEMENT Approved for Public Release; Distribution Unlimited			12b. DISTRIBUTION CODE
13. ABSTRACT (Maximum 200 Words) Related co-activators p300 and CBP, affect the transcriptional activities of many transcription factors (TF), producing multiple downstream effects. I have shown that the immediate early response TF, Egr1, acts upstream of p300/CBP to induce or to repress transcription, depending on stimulus. Cells induced with serum to increase endogenous Egr1, increase the transcription of p300/CBP, only when Egr1 binding sites in the promoter are not mutated, causing the expression of downstream targets of Egr1 leading to survival. Induction of p300/CBP by Egr1, results in acetylation and stabilization of Egr1 and transactivation of survival genes but repression of Egr1 and p300/CBP in negative feedback loops. In contrast, induction of Egr1 by UV-C irradiation leads to repression of p300/CBP transcription: Egr1 is preferentially phosphorylated, leading to regulation of target genes that cause cell death. This complex balance of opposing effects appears to finely modulate important cellular life and death responses. I have shown that serum stimulation of prostate cells results in cell growth by the up-regulation of p300/CBP. In contrast, the stimulus of ultraviolet irradiation leads to cell cycle block and apoptosis through the inhibition of p300/CBP.			
14. SUBJECT TERMS Egr1, transcription regulation, co-activators, p300 and CREBBP			15. NUMBER OF PAGES 25
			16. PRICE CODE
17. SECURITY CLASSIFICATION OF REPORT Unclassified	18. SECURITY CLASSIFICATION OF THIS PAGE Unclassified	19. SECURITY CLASSIFICATION OF ABSTRACT Unclassified	20. LIMITATION OF ABSTRACT Unlimited

Table of Contents

Cover.....	1
SF 298.....	2
Table of Contents.....	3
Introduction.....	4
Body.....	5
Key Research Accomplishments.....	12
Reportable Outcomes.....	12
Conclusions.....	12
References.....	12-15
Appendices.....	15-25

Egr1 target genes that regulate growth/survival of prostate cells.

INTRODUCTION

Immediate early growth response-1 gene, *EGR1* (also called Zif268, NGFIA, Tis8 and Krox24) (Christy et al., 1988; LeMaire et al., 1988; Lim et al., 1987; Milbrandt, 1987; Sukhatme et al., 1988) encodes a zinc-finger transcription factor whose expression is elicited in response to a diverse variety of extracellular signals, including growth factors, cytokines, phorbol esters, irradiation, and stresses of many kinds in a rapid and transient manner. Egr1 is a protein that can bind to a GC-rich element in the promoters of a range of target genes. Growth factor stimulation of most cells leads to rapid induction of Egr1 within minutes that leads to the activation of downstream growth pathways in normal cells. Egr1 can also suppress growth when over-expressed or re-expressed in transformed cells (Huang et al., 1998b; Huang et al., 1995). The cellular responses to Egr1 are also duplicitous in relation to apoptosis. Egr1 can induce apoptosis either by stimulating p53 expression (Ahmed et al., 1997; Ahmed et al., 1996; Nair et al., 1997) or PTEN expression (Virolle et al., 2001). However, Egr1 can also promote survival in other cell types (de Belle et al., 1999; Huang et al., 1998a; Huang and Adamson, 1995; Nair et al., 1997) by slowing growth via p21/Cip1 induction. It appears that Egr1 can act as a tumor suppressor in some cells but as a growth stimulator in others. An example of the latter is in human prostate tumors where Egr1 is over-expressed (Eid et al., 1998; Mohiuddin et al., 1997; Thigpen et al., 1996) but is low or absent from normal prostate tissue. Moreover, the level of Egr1 increases with the degree of malignancy as measured by the Gleason score of the tumor (Gleason, 1988) (Eid et al., 1998). Mouse models using Egr1 knockout and transgenic mice (the TRAMP mouse model) support the conclusion that Egr1 is required for tumor progression. (Abdulkadir et al., 2001; Baron et al., 2003; Virolle et al., 2003). This is significant and specific to prostate tumor cells because in mammary, lung and glial tumors, Egr1, is not over-expressed.

The protein products of the paralog genes, p300 and CBP (also known as CREB binding protein, CREBBP), are large and possess multiple binding domains for at least 30 transcription factors that allow them to act as multifunctional adapter proteins with acetyl transferase activity for transcription factors and for histones. Thus, they affect chromatin structure and can have multiple effects on downstream target genes (Frisch and Mymryk, 2002). The protein pair, p300/CBP, is important in both cell cycle progression and cellular differentiation and has been shown to interact with components of the RNA polymerase II holoenzyme, transcription factors, and nuclear hormone receptors and their co-activators. Mutations in the transcription factor binding domain of these genes occur in several types of tumors (Kasper et al., 2002). Transcription factors regulated by acetylation *via* p300/CBP include Myb, Creb, Ets-1, p53, c-Jun, c-Fos, MyoD, Stat1, Stat2 and AR. CBP and p300 associate with PCAF, and all have histone acetyltransferase (HAT) activity. The complex formed between CBP/p300 and PCAF is disrupted by the adenoviral protein E1A (Chakravarti et al., 1999), leading to suppression of p53 transactivation (Somasundaram and El-Deiry, 1997). The amino terminal 80 amino acids of E1A also binds p300 and CBP, to block the acetyltransferase activity and effectively negate their co-activation roles (Dorsman et al., 1997; Eckner et al., 1994) and this has proved a valuable tool in these studies. Thus loss of complex formation with p300/CBP occurs to affect transactivation of the target genes. The transcriptional regulation of p300/CBP has not yet been described. It has already been reported that both Egr1 and p53 activities are upregulated by the activity of p300/CBP and that there is a physical interaction of the p300/CBP proteins with p53 and Egr1 while co-activating their transcriptional activities (Lill et al., 1997; Shikama et al., 1999; Silverman et al., 1998).

SCIENTIFIC BODY

The SOW is in three parts. The report below includes activities and positive results on all three Tasks listed except for EMSA measurements that became redundant by the clear indication of the binding of Egr1 protein to the p300 and CBP promoters using the superior assay of chromatin immunoprecipitation.

I can report therefore that all Tasks have been undertaken but not yet completed to the highest degree due to the complicated inter-relationship between Egr1 and its target genes p300 and CBP that I uncovered (See Figure 11 in the Appendix). The results have deep implications for very versatile regulatory loops that would be required for such an important biological control system involving genes that regulate growth, survival and apoptosis of cancer cells.

The results are described next (with figures in the Appendix):-

The promoters of p300 and CBP are highly GC-rich and contain many consensus and other binding motifs for Egr1 transcription factor. This prompted us to determine if alteration of Egr1 expression in cells that express Egr1 constitutively, might regulate p300/CBP. Figure 1A shows that reduction of Egr1 levels with antisense oligonucleotides affects the expression levels of p300/CBP in prostate cancer cells. Uptake of the highly specific oligonucleotides described previously (Virolle et al., 2003) by transfection of the malignant prostate cancer cell line, M12 completely negated Egr1 expression at 0.2 μ M and also drastically reduced p300 and CBP protein (Figure 1A) and mRNA expression (Figure 1B). Over-expression of Egr1 in contrast increased p300/CBP expression (see data below) These results led to the following study that defined the role of Egr1 chiefly in prostate cancer cells to show that the regulation is not simple and involves several feedback loops.

The promoter and 5'-UTR fragments of CBP and p300 genes contain many potential Egr1 binding sites

The CBP and p300 regulatory sequences including 2-kilobase (kb)-promoter sequences and 5'-UTR sequences upstream of the translation start site were analyzed for Egr1 binding sites (EBS). Egr1 binds to the consensus sequence GNGGGGNG (Pavletich and Pabo, 1991) and to a variant EBS in the PTEN promoter GCGGCGGCG (Virolle et al., 2001). These are proven EBS and together with sequence GCGG/TGGGCG can be regarded as Egr1 binding sites as well as binding sites for the Wilm's tumor protein, WT1. WT1 generally inhibits the transcription of the same genes that Egr1 induces. Using only the highest affinity binding sequences GNG(T/G)GGG(T/C)G (Hamilton et al., 1998) for Egr1, we found that there are 6 and 7 sites in the p300 and CBP regulatory regions, respectively, and labeled **a** through **f** in Figure 2A.

p300 and CBP promoter-luciferase reporter genes were constructed as described in the Experimental procedures section, pGL3-p300 and pGL3-CBP, as constructs containing the 5' non-coding region of the genes. The reporter construct was also made with putative EBS mutated at 3 or 4 consecutive bases, to yield single site and multiple site mutated versions to determine which sites are active. Figure 2B indicates that for the p300 promoter, all sites have some activity in H4 cells after transfection of an Egr1 vector, such that p300mut-**abcdef** was not activated by Egr1, while wt reporter was expressed at 6-fold higher levels compared to the empty vector, pcDNA3. Intermediate values obtained for double mutants became lower as all sites were mutated. There was little distinction between "perfect consensus" sites and non-consensus sites, all EBS added some activity to the 6-fold increase in p300 promoter activity (Figure 2B) but a graded response was evident based on how many EBS were available. Similarly, the CBP-luciferase construct was tested on pGL3-full-length CBP and on pGLCBP with one mutated EBS, and similar results were obtained, except activation was lower at 5-fold (data not shown).

Egr1 binds directly to CBP/p300 regulatory sequences in vivo

In order to assess whether direct binding of Egr1 to the CBP or p300 regulatory sequences occurs in intact cells, we performed chromatin crosslinking with formaldehyde followed by immunoprecipitation with antibodies to Egr1. To detect DNA binding under two different conditions, Egr1 levels were induced in DU145 prostate carcinoma cells by the addition of serum for 1 h or 2 h after UV irradiated M12 cells. The sonicated chromatin fragments were processed essentially as described (de Belle et al., 2000) for chromatin immunoprecipitation (ChIP) with antibody to Egr1. PCR was used to detect DNA specific to CBP and p300 promoters that had been pulled down by the anti-Egr1. Figure 2C shows that the fragments B, and C in CBP ChIP products contain Egr1 binding sites, since primers specific to that fragment showed a DNA product in the anti-Egr1 (α E) and the DNA input (positive control) lanes in B and C but not for A fragment. Similarly, the p300 promoter and 5' regulatory sequences were represented by fragments A to D. All of these DNA fragments were shown to contain EBS that bound Egr1 since the anti-Egr1 immunoprecipitated a DNA fragment that was detected by PCR using specific primers. The same DNA samples were also used for amplification using primers to detect cyclophilin in the ChIP products as a negative control. An additional control was provided by the inability of non-immune serum to immunoprecipitate these DNA fragments. This demonstrated that Egr1 can bind directly to most of the binding consensus sequence-containing fragments that we tested and it does so in live cells that express endogenous Egr1. We next asked whether this binding has an effect on the regulation of the gene when endogenous Egr1 is elevated by a stimulus such as serum or UV-C irradiation.

p300 and /CBP are up-regulated by Egr1 in serum-induced prostate cancer cells and in mouse embryo fibroblasts (MEFs)

Metastatic prostate cancer cells, M12, were made quiescent by serum starvation and then were serum stimulated. mRNA levels were assayed by quantitative RT-PCR over a time course from 15 to 120 min. Figure 3A shows that the levels of Egr1 mRNA were maximal at 30-45 min while p300 and CBP mRNAs rose slowly and were maximal at 60 min. Western blots to assay protein levels over a longer time course were made in 6 cell lines. In wt MEFs, Egr1 protein was maximal at 1h, while p300 and CBP peaked at 3h. As expected, if Egr1 is regulating transcription of the p300/CBP proteins, no changes were seen in Egr1 null MEFs (Figure 3B). Different levels of proteins were seen in four different prostate cell lines serum starved and then stimulated with 20% serum, and the same pattern was observed. We concluded that independent of the cell type, Egr1 induction by serum increased the expression of the p300/CBP genes (Figure 3C).

CBP /p300 genes are directly down-regulated by Egr1 during UV irradiation-induced signaling

We showed earlier that ultraviolet-C (UV-C) irradiation upregulates the production of Egr1 protein (Huang et al., 1996). We used UV-C irradiation to stimulate endogenous Egr1 levels in four prostate cell lines to show that 2 h after irradiation with UV-C at 40 Jm^{-2} , the mRNA levels of CBP and p300, quantified by real time one step RT-PCR, were downregulated in these four cell types. Compared to P69 cells, the inhibition of mRNA levels for CBP and P300 in M12 cells was greater. In M12 cells and P69 cells, p300 mRNA levels were 6.7-fold and 1.5 fold lower, $p < 0.01$, respectively. For CBP, M12 gave 2.7-fold and P69 gave 1.5 fold lower mRNA levels than untreated cells with $p < 0.01$ (Figure 4A).

The results of Western blot analyses in Figure 4B are consistent with mRNA levels, to show that 2.5h after irradiation with UV-C at 40 Jm^{-2} , Egr1 was elevated in all four cell lines, while CBP and p300 proteins were obviously decreased in DU145 and M12 cells, indicating that these two genes were down regulated when Egr1 was elevated. However, both CBP and p300 were not much changed in the normal 267B1 and low tumorigenic P69 cell lines (Figure 4B) suggesting that perhaps highly transformed cells were affected the most.

Since the protein levels of p300 and CBP after UV-C irradiation of DU145 and M12 cells are strongly reduced while Egr1 is elevated in this condition we concluded that Egr1 appears to be responsible by direct transcriptional down-regulation by binding to the promoters of CBP and p300 and inhibiting

their transcription rate. As a further test, we applied antisense (AS) Egr1 oligonucleotides to the UV-C irradiated M12 cells to reduce the Egr1 expression level specifically without affecting other gene products. Figure 4C shows the resulting mRNA levels by QRT-PCR (left panel) and protein levels by immunoblotting (right panel) in the M12 cells, 2h and 2.5 h after irradiation, respectively. In this case Egr1 protein levels were significantly reduced (Fig 4C) by the AS oligonucleotide treatment compared with the cells that were treated with scrambled oligonucleotides (SCR). In parallel, the level of CBP and p300 mRNAs and proteins were elevated, indicating that in the absence of Egr1, both p300 and CBP genes are expressed at higher levels. These results are consistent with UV-C induced Egr1 causing the transcriptional inhibition of the expression of p300/CBP.

What is the mechanism of this differential response to elevated Egr1 levels?

First we set about proving that the Egr1 induced by serum and Egr1 induced by UV-C were different in their transactivating properties. Using dual luciferase reporter assays, we demonstrated that serum and exogenous Egr1 induce p300 and CBP promoter-luciferase activity in M12 (not shown) and 293T cells (Figure 5A). Transfection of WT1 strongly decreased luciferase as did the Egr1 dominant negative construct (WT1/Egr1) (Drummond et al., 1992; Rauscher, 1993) or UV-C. This result suggests that Egr1 is the agent responsible for up-regulating p300 and CBP promoters, and that preventing activated Egr1 from binding, blocks this effect.

We and others have shown that Egr1 becomes phosphorylated in activated cells (Cao et al., 1992; Huang and Adamson, 1994) and several kinases have been shown to interact with Egr1. Evidence in the literature suggests that Egr1 is physically associated with casein kinase2 (CK2) and in NIH3T3 cells this results in phosphorylation of Egr1 and accounts for decreased DNA binding and reduced transactivating activities of Egr1 (Jain et al., 1996; Srivastava et al., 1998). We know that UV irradiation does not prevent Egr1 from binding to promoters that it regulates (Fig 2XX), therefore we tested whether any common kinase inhibitors affected the reporter activities, this time in H4 cells (which have no Egr1 expression and Egr1 is non-inducible by serum or UV-C) in the absence or presence of H7, an inhibitor of PKA, PKC and PKG; Genistein, an inhibitor of PKA, PKC and tyrosine kinases; Tyrphostin AG1112, also a tyrosine kinase inhibitor; or DRB and Apigenin (Ser and Thr phosphokinase inhibitors of CK2). Figure 5B indicates that as expected, exogenous Egr1 induces luciferase activity and this is reduced after UV-C irradiation. This lower level remains unchanged with the addition of three kinase inhibitors, while CK2 inhibitors restored luciferase expression levels to that achieved by Egr1 alone, suggesting that CK2 plays a role in the inhibitory effect of Egr1 after UV-C treatment. An immunoblot study in M12 cells showing p300, CBP, Egr1 and acetylated Egr1 expression was perfectly consistent with this result (data not shown). Although inhibitors of kinases only partially inhibit activity at non-toxic levels, the results indicate that CK2 plays a role in the regulation of transcription by Egr1.

Egr1 is phosphorylated in a CK2-dependent manner

To determine if Egr1 in cells is phosphorylated differentially according to the stimulus, M12 cells were subjected to radioactive inorganic [³²Pi]-phosphate labeling, after a stimulus of serum or UV-C, and in the absence or presence of DRB, an inhibitor of CK2. CK2 is induced by UV-C in a mechanism involving p38 MAPK (Kato et al., 2003). The immunoprecipitated Egr1 after UV-C irradiation showed that Egr1 was strongly phosphorylated and this was reduced to one third by the inhibitor of CK2, DRB (Fig. 5C). In contrast, serum stimulated cells were weakly phosphorylated in the presence or absence of DRB. We concluded that UV-C irradiation leads to the induction of phosphorylated Egr1 that acts to repress the transcription of p300/CBP.

Feed-back regulation of Egr1 transcription by Egr1 and by p300/CBP

We noticed that the Egr1 promoter has three high affinity Egr1 binding sites that could self-regulate its transcription. We tested this by using an pGL3-Egr1 promoter-luciferase reporter gene in 293T cells transfected with Egr1 as well as p300 and CBP expression vectors. Figure 6A shows that Egr1 increased the transactivation of its own promoter two-fold while p300 and CBP expression decreased Egr1-luciferase transcription also by about two-fold. In contrast, the transfection of full-

length E1A increased Egr1 transactivation, presumably by binding to p300/CBP to prevent the co-activators from inhibiting the Egr1 promoter reporter. This suggestion was further supported by transfecting RNAi against p300 and against CBP into H4 cells where Egr1 is not detectable, to show first that CBP and p300 are inhibited in transcription (Fig 6B) and in translation (Fig 6C). Then we applied the RNAi to H4 cells to find that Egr1 mRNA was increased 3-fold and 12-fold, respectively, by RNAi to CBP or RNAi to p300. Moreover, E1A amino-terminal and full-length E1A vectors transfected into H4 cells increased Egr1 mRNA levels by 40- and 100-fold respectively (Fig 6D). Egr1 protein also appeared after E1A transfection although in low amounts in these cells (data not shown). These results indicate that removal of p300 and CBP allows the expression of Egr1 in cells that were always supposed to be Egr1 null. Thus a negative feedback loop by p300/CBP could be operating in some or most cell types in order to curtail any long-lasting effects of high Egr1 levels.

Egr1 can be acetylated by p300/CBP in vivo and forms a complex with p300/CBP with negative feedback activity.

p300/CBP bind transcription factors at one of several cysteine and serine-rich (C/H) domains to form complexes for transcriptional co-activation. One of the requirements for stabilizing these complexes is the acetylation of the TF at a basic consensus sequence. A potential acetylation site (KDKK) occurs at amino acids 424 to 428 in Egr1, close to the third zinc finger, as the end portion of the nuclear localization signal which is unusual in that it includes all three zinc fingers and does not rely solely on basic residues (Matheny et al., 1994). This motif is very similar to that in p53 (KSKK) and other transcription factors that are acetylated by p300/CBP. We first tested if Egr1 is acetylated using cells that were treated with Trichostatin A (TSA) to inhibit deacetylases. Culture of M12 prostate cells with TSA for 6h increased the effectiveness of the acetyl transferases of the cells so that the proportion of Egr1 that was acetylated was increased as shown using anti-acetylated lysine antibodies (Figure 7A row 4) compared to the total immunoprecipitated Egr1 (Fig 7A, row 3). TSA at 2 μ M had a maximal effect on increasing acetylated Egr1 levels (lane 4). As a result, the expression of p300 decreased in a dose dependent manner (Fig 7A, top row). The levels of each protein in Fig 7A suggest that deacetylase-depletion in the cells results in increased levels of acetylated proteins, as seen for Egr1 (Fig 7A, bottom row) and that this acetylated form of Egr1 is the species that inhibits p300 expression (Fig 7A, top row).

We then determined if acetylation of Egr1 occurred at the KDKK site by mutating these residues singly or in combination in an Egr1 expression construct with a Flag tag for co-immunoprecipitation, and immunoblotting after transient transfection into 293T cells. In Figure 7B we used Flag-tagged Egr1 and HA-tagged p300 in order to use a combination of immunoblotting (upper panel) and co-immunoprecipitation (lower panel). Immunoblotting showed that each construct was expressed in addition to endogenous p300, but p300 was best expressed in the presence of the Ac-mut Egr1 (KDKK to aDaa) (Fig 7B, row 3, lane 8). The same lysates immunoprecipitated with anti-Flag-tagged Egr1, co-precipitated p300 (Fig 7B, lower panel) as a complex with wt Egr1 or its two mutant forms. Only the triple Ac-mutant Egr1-aDaa was unable to interact with p300 and was unable to pull down much p300 (Fig 7B, lane 8). But since the western blot shows that p300 was expressed best under these circumstances, we concluded that mutant Egr1 was still competent in inducing p300/CBP transactivation because all Egr1 forms were able to stimulate p300 or CBP transactivation compared with non-acetylated Egr1 (compare lower panel, lane 8, row 2, with lanes 2, 4 and 6). The non-acetylated mutant, Egr1-aDaa, was unable to co-immunoprecipitate with p300 while the acetylated forms were capable in this respect (Fig 7B, lanes 2, 4 and 6). The effect of serum is to induce p300/CBP via Egr1 which is then acetylated and now binds to p300/CBP. In contrast, it appears that phosphorylated Egr1 plays the role of inhibiting transcription of p300 following the UV-irradiation of cells (Figure 5C).

The following results suggest that the complex of Ac-Egr1 with p300/CBP has a different effect on the transcriptional regulation of p300/CBP compared with Ac-mutant Egr1. This was tested in 293T cells (which express endogenous wt-Egr1) by transfection of several expression vectors in order to measure the transcriptional effect of exogenous wt-Egr1 versus Ac-mutant Egr1, transfected

together with p300 or CBP expression vectors on the p300 promoter-luciferase construct. Figure 7C shows that even without extra Egr1 (No Egr1 bars) the expression of p300 or CBP was able to inhibit transactivation of the promoter. Similarly, the presence of wt-Egr1 (KDKK), inhibited transcription in a fashion that suggested that the p300/CBP is acetylating the Egr1 to cause the inhibition. This was supported by the transfection of Ac-single, or double or triple mutant forms of Egr1, the last of which was unable to inhibit the transactivation of the p300 reporter. This means that there is a negative feed-back loop on p300 transcription by the Ac-Egr1/p300/CBP complex but not by the non-acetylated Egr1, since this form increases the transcription of p300.

Conditions for the acetylation of Egr1

We hypothesized that after serum stimulation, new Egr1 protein is not acetylated at its peak (1h) expression level, but only later after it has stimulated p300/CBP, when it becomes acetylated by its product and perhaps to alter the range of its target genes (see below). By this time p300/CBP expression is high and can then inhibit the transactivation of Egr1 as described in the section on feedback inhibition. We tested this using a time course of serum or UV stimulation in M12 cells (Figure 8A). Only in UV irradiated cells does Egr1 protein level increase starting at 1h and remain high for 3-4 h. Only in UV irradiated cells does p300 decrease most when Egr1 is at its highest. Therefore Egr1 might be mainly un-acetylated in UV irradiated cells but may be rapidly phosphorylated (Figure 5C) and hence become less able to transactivate (Jain et al., 1996). Immunoprecipitation of Egr1 in these samples shows that acetylated Egr1 in the IP is highest in serum-stimulated cells only after 2-3 h (Figure 8B, row 1) which is in temporal agreement with the highest levels of p300 in Figure 8A. In untreated cells, the initial levels of acetylated Egr1 are moderately high and decrease only after 3 h in UV-C-treated cells (Fig 8B, lane 4) in accord with the results of Fig 8A. Immunoprecipitation of Egr1 in M12 cells compared with P69 and DU145 shown in Figure 8C indicates that this result is common to three different prostate cancer cell lines. The untreated cells have high levels of acetylated Egr1 suggesting that p300 must keep acetylation high until UV irradiation causes Egr1 elevation, followed by reduction of p300 expression to low levels as Ac-Egr1 inhibits transcription. Thus we conclude that acetylated Egr1 is stable or actively maintained at high levels in serum-stimulated cells, while a genotoxic stimulus causes a net gain of phosphorylated Egr1 (Fig, 5C) that has an inhibitory effect on the transcription of p300 (Fig 8A).

Further test of Egr1 stabilization by acetylation.

We have shown that in addition to acetylation of Egr1 by p300 or CBP, a complex of the two proteins may allow both to become more stable and more active. To test the conditions for Egr1 stability, 293T cells were transfected with Flag-tagged wt Egr1 or Ac-mut Egr1, with or without the addition of HA-tagged p300. All were well expressed as shown in the immunoblot in Figure 9A. When the cells were immunoprecipitated with anti-Flag, the immune-complex contained acetylated Egr1 when wt-Egr1 was present in the cells (Fig 9A, lane 2, row 7). No mutAc-Egr1 was seen in the Egr1-precipitated complex. Meanwhile a sample was also treated with cycloheximide (CHX) to inhibit protein synthesis and allow the degradation of short-lived proteins. As a result (Fig 9A, row 6) only the Egr1 that had been acetylated (lane 2) was substantially preserved 1h after CHX addition and even more stable when in the presence of excess p300. This is a direct demonstration of the improved stability of acetylated Egr1 when complexed with p300.

In the stabilized complex of p300 with Ac-Egr1 there may be other factors that affect transcription, such as p53, however, p53 is inactivated in 293T cells. We tested co-immunoprecipitated proteins using anti-Flag-Egr1, for other proteins that may also bind specifically to Egr1 or to the Ac-Egr1/p300 complex. Figure 9B shows that while only acetylated-Egr1 binds well to p300, MDM2 and p53 are also both able to bind the Ac-Egr1 complex as well as non-Ac Egr1 in the absence of p300 (Fig 9B, lane 1, rows 4 and 5). It is possible that the binding of MDM2 to non-Ac-Egr1 is indirect through binding to p53 which is known to bind to Egr1 (Liu et al., 2001).

Non-acetylated/phosphorylated Egr1 is more active in regulating genes towards apoptosis while acetylated Egr1 is required for the regulation of growth and survival genes.

Cells in culture for the most part respond to 20% serum after starvation by stimulation of Egr1 and then this upregulates its target genes that are known to lead to growth and survival. In contrast, cells that are UV-C irradiated (40 JM^{-2}), cause growth arrest, repair of DNA damage and/or apoptosis. We therefore studied 8 known or suspected Egr1 target genes to determine if highly-acetylated Egr1 produced a different result compared with under-acetylated Egr1 (UV-C). We applied quantitative RT-PCR to measure the levels of mRNA produced in M12 prostate cancer cells. Figure 10A shows that serum strongly induced the expression of FGF2, IGF2, PDGFB, and was less active in inducing TGF β 1, BCL2, NF κ B, p50 and p65, while p73 was inhibited. The stimulus of UV-C, on the other hand reduced the expression of FGF2, IGF2, NF κ B and BCL2, while increasing the expression of PDGFB and p73 with a small effect on TGF β 1. This effect could be produced by under-acetylated Egr1 or by phosphorylated Egr1. To demonstrate this point in a different way, a transient expression study was used in 293T cells, by measuring the mRNA levels of the same genes after transfection with wt-Egr1 or Ac-mut-Egr1 with or without exogenous p300. The results in Figure 10B show that for the six target genes which wt-Egr1 induces (FGF2, PDGFB, TGF β 1, NF κ B p50 and p60), the non-Ac-Egr1 was inactive in accord with the previous conclusion that serum-stimulated genes require acetylated-Egr1 for transactivation. For genes p53 and p73, mRNA levels were increased only by non-acetylated-Egr1 as seen in UV-C-induced cells. For p73, we investigated the effect of acetylation on the induction of the three isomers, α , β and γ , as well as p53 and actin to show that the non-acetylated form of Egr1 stimulates the expression of all protein isoforms three-fold more efficiently than wt-Egr1 (Figure 10C). The non-acetylated form predominates in UV-C treated cells and up-regulated p53 and p73 then results in an increase in susceptibility to apoptosis.

M12 cells express a moderate level of Egr1 as a constitutive protein and we have shown that at least some of this is already acetylated. This is consistent with the constant stimulation of the growth factor genes by constitutive acetylated Egr1 that gives this cell line its transformed character and survival properties. We estimated the effect on survival by measuring the level of cell death in M12 cells expressing exogenous genes, such as CBP RNAi, p300 RNAi, both RNAis, E1A(1-80), and E1A wt in a series wherein the % of dead cells was increased (Figure 10D, lower trace). The percentage of dead cells was counted as Trypan Blue-stained cells after 24h together with the total number of cells alive or dead in triplicate dishes. The reduction of the number of cells in the last three conditions indicates that cell proliferation declined in these samples in addition to increasing levels of cell death. These samples all had reduced p300/CBP protein that would increase Egr1 transcription but also reduce the stability of Egr1 protein while increasing the activation of p53 and p73, and in consequence reduce the growth and survival of these prostate cancer cells through increased ability to stimulate the apoptotic genes.

This paper demonstrates that the transcription factor Egr1 is a key component in the early responses to environmental signals that regulate a large group of transcription factors through its regulation of the coactivators p300 and CBP. We have focused on the response to serum after serum starvation and the response to UV-C because the effects of Egr1 appeared to be diametrically opposed. Whereas serum-induced Egr1 caused up-regulation of p300/CBP (Fig.3), UV irradiation lead to down regulation of the promoter reporter construct (Fig. 4). This was a surprising result and we sought to determine the mechanism. As a result, we found that many more complicating events occurred during the responses of cells to these extracellular stimuli. We found that a signal to up-regulate Egr1 expression could be self-sustained by positive feedback of Egr1 protein on its own transcription (Fig. 6A). In contrast, after the transactivation of the p300/CBP promoters by Egr1, a negative feedback of p300/CBP on Egr1 transactivation occurs (Fig. 6B,C,D) and also a negative feedback loop operated by acetylated Egr1 or by its complex with p300/CBP on the transcription of p300/CBP occurs (Fig. 8A,B, and the scheme is summarized in Figure 11). When UV-C is the stimulus however, Egr1 is induced as a phosphorylated entity (Fig. 5C) and this form is repressive to transcriptional activity of the promoters of p300/CBP (Fig 5A,B). We cannot exclude the possibility that the ratio of acetylated to non-Ac-Egr1 or to phosphorylated Egr1 is the important trigger to its choice of activities. Reduced levels of p300/CBP exclude the acetylation of Egr1 or reduce its level compared to levels of phosphorylated Egr1. The effect of specific phosphorylation sites on Egr1 has not been explored to any extent yet because of the large numbers of possible phosphorylated

residues that present a problem in mapping and analyzing. The biological result of the serum-induced pathway is that acetylated Egr1/p300/CBP complexes activate growth and survival, while UV-C irradiation leads to gene regulations that slow growth and that lead to apoptosis. This explains some of the dual roles of Egr1 in cellular responses and physiology.

From the work of Silverman et al, (Silverman et al., 1998) it was suggested that interactions of p300 and CBP with Egr1 resulted in the potentiation of the transactivation activity of Egr1. This occurs in the case of p300/CBP and p53 and might therefore be true for most transcription factors that interact with p300 (Sakaguchi et al., 1998). We show here that for Egr1 potentiation by p300/CBP occurs for a selection of target genes only (Fig. 10). Of the transcription factors that bind to p300/CBP, some bind to the C/H1, some to C/H2 or to C/H3 binding domains, therefore, effects of p300/CBP might be seen for several transcription factors simultaneously. For example, in lipopolysaccharide stimulated macrophages, Sp1, Egr1, Ets/Elk, ATF2 and c-Jun, are all bound by p300/CBP to activate the TNF α gene promoter (Tsai et al., 2000). Here we show that acetylated Egr1 or its complex with p300/CBP proteins are inhibitory to the transcription of the p300/CBP and Egr1 genes (Fig. 7C, Fig 6D).

In summary, Egr1 responds to both genotoxic stress and to growth stimuli, with negative and positive actions on growth, respectively. The last attribute makes this transactivator different from its model, p53. Its modes of action and its controls are similar to p53, so much so that the activities of Egr1 could be seen as a general factotum or surrogate to p53 when the master tumor suppressor is disabled (Calogero et al., 2001). Moreover, p53 cannot function in the absence of Egr1 in mouse embryo fibroblasts (Krones-Herzig et al., 2003). It may be important to cancer control that the *EGR1* gene remains intact for the most part in cancer cells and very few mutations have been described. Its importance to tumor suppression is clear for breast (Huang et al., 1997), fibrosarcoma (Huang et al., 1998b) brain (Calogero et al., 2001) and lung (Levin et al., 1995) tumors because in these tissues Egr1 is poorly expressed and acts as a growth and transformation suppressor when over-expressed. In contrast, in prostate cancer, Egr1 is an important component in the transformation and progression of the disease by its constitutive expression. This major difference is likely highlighted by the fact that there are even more ways to regulate the activities of Egr1 post-transcriptionally than p53, such that mutation of the gene is not under pressure. This fact enlarges the importance of Egr1 in its myriad of roles and the variety of regulatory measures to modulate any large changes in its expression. In prostate cancer, a positive feedback loop from Egr1 and from growth factor products on the Egr1 promoter occurs to provide constitutive growth. This provides a high constitutive level of acetylated Egr1 which is more stable. Whether the transactivating and other properties of the stable acetylated form are different remains to be determined, but it does affect its choice of target genes (Fig. 10).

Prostate cancer tissue has high levels of p300/CBP proteins and the level increases with the Gleason score (Debes et al., 2003) as is the case for Egr1 (Abdulkadir et al., 2001; Baron et al., 2003; Eid et al., 1998). High p300 levels are associated with prostate cancer growth and is a predictor of progression (Debes et al., 2003). This co-overexpression can now be explained by transcriptional activation of p300 by Egr1 and sustained by growth factor targets of Egr1 and positive feedback. For practical applications, in prostate cancer the reduction of Egr1 might be effective in clinical treatments, because this will reduce growth factor induction and positive feedback. Low Egr1 would still be inducible by irradiation of all kinds just as it is in breast cancer cells and this would lead to repression of p300/CBP and apoptosis by the activation of Egr1 target genes that are induced after stress. These include FASL, PTEN and TNF α genes that are pro-apoptotic when activated. However, the number of counter-measures that the cells provide to regulate Egr1 make prediction of a general therapy regime difficult, all the more so because of its differential effects on different tissues. Further animal studies (Baron et al., 2003) will help to decide if antisense Egr1 might be an effective treatment for prostate

KEY RESEARCH ACCOMPLISHMENTS

- Cloned full-length, and fragments of the EP300 and CREBBP genes for analysis of function
- Determined that p300 and CBP are transcriptionally regulated by Egr1
- Shown that the relationship between Egr1 and p300/CBP is complex with 4 feedback regulatory loops
- Egr1 both up-regulates p300/CBP and down-regulates these genes depending on the stimulus on the cells,
- Submitted a paper to Molecular Cell, now under revision for re-submission.

REPORTABLE OUTCOMES

1. I have shown that Egr1 has a complex relationship with its target genes p300/CBP.
2. All three genes are important in prostate cancer: Egr1 expressed in prostate cancer cells is an oncogene because growth factors and high levels of p300/CBP continually give positive feedback and growth. But when prostate cells are irradiated, the p300 and CBP genes in prostate cancer cells are induced by Egr1 to switch off, thus growth slows and DNA damage eventually cause cells to enter apoptosis.
3. This is the first report of the transcriptional regulation of p300/CBP.
4. This is the first time that it has been shown that Egr1 becomes acetylated by p300/CBP and binds physically to these large proteins to become stabilized.
5. A paper is in the review process.

CONCLUSIONS

1. I am happy to report that the difficulties in understanding the complexities of p300/CBP are becoming resolved and that I have solid data to show some of the mechanism underlying these findings.
2. Next, I want to go deeper into the mechanism and to determine how acetylation of Egr1 affects its activities and how phosphorylation leads to entirely different physiological activities.
3. I have also found that the tumor suppressor gene, p73 is a target gene of Egr1 that can be both up and down regulated. If there is time. I want to explore the activities of this important gene in prostate cells.

REFERENCES

- Abdulkadir, S. A., Qu, Z. C., Garabedian, E., Song, S. K., Peters, T. J., Svaren, J., Carbone, J. M., Naughton, C. K., Catalona, W. J., Ackerman, J. J. H., *et al.* (2001). Impaired prostate tumorigenesis in Egr1-deficient mice. *Nat Med* 7, 101-107.
- Ahmed, M. M., Sells, S. F., Venkatasubbarao, K., Fruitwala, S. M., Muthukkumar, S., Harp, C., Mohiuddin, M., and Rangnekar, V. M. (1997). Ionizing radiation-inducible apoptosis in the absence of p53 linked to transcription factor Egr-1. *J Biol Chem* 272, 33056-33061.
- Ahmed, M. M., Venkatasubbarao, K., Fruitwala, S. M., Muthukkumar, S., Wood, D. P., Jr., Sells, S. F., Mohiuddin, M., and Rangnekar, V. M. (1996). EGR-1 induction is required for maximal radiosensitivity in A375-C6 melanoma cells. *JBiolChem* 271, 29231-29237.
- Baron, V., De Gregorio, G., Krones-Herzig, A., Virolle, T., Calogero, A., Urcis, R., and Mercola, D. (2003). Inhibition of Egr1 expression reverses transformation of prostate cancer cells in vitro and in vivo. *Oncogene* 22, 4294-4204.
- Calogero, A., Arcella, A., De Gregorio, G., Porcellini, A., Mercola, D., Liu, C., Lombardi, V., Zani, M., Giannini, G., Gagliardi, F. M., *et al.* (2001). The early growth response gene EGR-1 behaves as a suppressor gene that is down-regulated independent of ARF/Mdm2 but not p53 alterations in fresh human gliomas.[erratum appears in *Clin Cancer Res* 2002 Jan;8(1):299]. *Clinical Cancer Research* 7, 2788-2796.

- Cao, X., Mahendran, R., Guy, G. R., and Tan, Y. H. (1992). Protein phosphatase inhibitors induce the sustained expression of the Egr-1 gene and the hyperphosphorylation of its gene product. *JBiolChem* 267, 12991-12997.
- Chakravarti, D., Ogryzko, V., Kao, H. Y., Nash, A., Chen, H., Nakatani, Y., and Evans, R. M. (1999). A viral mechanism for inhibition of p300 and PCAF acetyltransferase activity. *Cell* 96, 393-403.
- Christy, B., Lau, L. F., and Nathans, D. (1988). A gene activated in mouse 3T3 cells by serum growth factors encodes a protein with "Zinc finger" sequence. *ProcNatAcadSciUSA* 85, 7857-7861.
- de Belle, I., Huang, R.-P., Fan, Y., Liu, C., Mercola, D., and Adamson, E. D. (1999). p53 and Egr-1 additively suppress transformed growth in HT1080 cells but Egr-1 counteracts p53-dependent apoptosis. *Oncogene* 18, 3633-3642.
- de Belle, I., Mercola, D., and Adamson, E. D. (2000). Method for cloning in vivo targets of the Egr-1 transcription factor. *Biotechniques* 29, 162-169.
- Debes, J. D., Sebo, T. J., Lohse, C. M., Murphy, L. M., Haugen de, A. L., and Tindall, D. J. (2003). p300 in Prostate Cancer Proliferation and Progression. *Cancer Res* 63, 7638-7640.
- Dorsman, J. C., Teunisse, A. F., Zantema, A., and van der Eb, A. J. (1997). The adenovirus 12 E1A proteins can bind directly to proteins of the p300 transcription co-activator family, including the CREB-binding protein CBP and p300. *J Gen Virol* 78, 423-426.
- Drummond, I. A., Madden, S. L., Rohwer-Nutter, P., Bell, G. I., Sukhatme, V. P., and Rauscher, F. J. I. (1992). Repression of the insulin-like growth factor II gene by the Wilms tumor suppressor WT1. *Science* 257(5070), 674-678.
- Eckner, R., Ewen, M. E., Newsome, D., Gerdes, M., DeCaprio, J. A., Lawrence, J. B., and Livingston, D. M. (1994). Molecular cloning and functional analysis of the adenovirus E1A-associated 300-kD protein (p300) reveals a protein with properties of a transcriptional adaptor. *Genes & Development* 8, 869-884.
- Eid, M. A., Kumar, M. V., Iczkowski, K. A., Bostwick, D. G., and Tindall, D. J. (1998). Expression of early growth response genes in human prostate cancer. *Canc Res* 58(11), 2461-2468.
- Frisch, S. M., and Mymryk, J. S. (2002). Adenovirus-5 E1A: paradox and paradigm. *Nat Rev Mol Cell Biol* 3, 441-452.
- Gleason, D. F. (1988). Histologic grade, clinical stage, and patient age in prostate cancer. *NCI Monogr*, 15-18.
- Hamilton, T. B., Borel, F., and Romaniuk, P. J. (1998). Comparison of the DNA binding characteristics of the related zinc finger proteins WT1 and EGR1. *Biochemistry* 37, 2051-2058.
- Huang, R.-P., and Adamson, E. D. (1994). The phosphorylated forms of the transcription factor, Egr-1, bind to DNA more efficiently than non-phosphorylated. *BiochemBiophysResCommun* 200, 1271-1276.
- Huang, R.-P., Fan, Y., de Belle, I., Ni, Z.-Y., Matheny, W., and Adamson, E. D. (1998a). Egr-1 inhibits apoptosis during the UV response: correlation of cell survival with Egr-1 phosphorylation. *Cell Death and Diff* 5, 96-106.
- Huang, R.-P., Fan, Y., Peng, A., Reed, J. C., Adamson, E. D., and Boynton, A. L. (1998b). Suppression of human fibrosarcoma cell growth by transcription factor, Egr-1, involves down-regulation of Bcl-2. *Int J Cancer* 77, 880-886.
- Huang, R.-P., Liu, C.-T., Fan, Y., Mercola, D. A., and Adamson, E. D. (1995). Egr-1 negatively regulates human tumor cell growth via the DNA-binding domain. *Cancer Res* 55, 5054-5062.
- Huang, R.-P., Wu, J.-X., Fan, Y., and Adamson, E. D. (1996). UV activates growth factor receptors via reactive oxygen intermediates. *JCell Biol* 133, 211-220.
- Huang, R. P., and Adamson, E. D. (1995). A biological role for Egr-1 in cell survival following ultra-violet irradiation. *Oncogene* 10, 467-475.

- Huang, R. P., Fan, Y., de Belle, I., Niemeyer, C., Gottardis, M. M., Mercola, D., and Adamson, E. D. (1997). Decreased Egr-1 expression in human, mouse and rat mammary cells and tissues correlates with tumor formation. *Int J Canc* 72, 102-109.
- Jain, N., Mahendran, R., Philp, R., Guy, G. R., Tan, Y. H., and Cao, X. (1996). Casein kinase II associates with Egr-1 and acts as a negative modulator of its DNA binding and transcription activities in NIH 3T3 cells. *J Biol Chem* 271(23), 13530-15336.
- Kasper, L. H., Boussouar, F., Ney, P. A., Jackson, C. W., Rehg, J., van Deursen, J. M., and Brindle, P. K. (2002). A transcription-factor-binding surface of coactivator p300 is required for haematopoiesis. *Nature* 419, 738-743.
- Kato, T. J., Delhase M, Hoffmann A, and M., K. (2003). CK2 Is a C-Terminal I κ B Kinase Responsible for NF- κ B Activation during the UV Response. *Mol Cell* 12, 829-839.
- Krones-Herzig, A., Adamson, E., and Mercola, D. (2003). Early growth response 1 protein, an upstream gatekeeper of the p53 tumor suppressor, controls replicative senescence. *Proc Natl Acad Sci USA* 100, 3233-3238.
- LeMaire, P., Relevant, O., Bravo, R., and Charnay, P. (1988). Two genes encoding potential transcription factors with identical DNA binding domains are activated by growth factors in cultured cells. *Proc Natl Acad Sci USA* 85, 4691-4695.
- Levin, W. J., Press, M. F., Gaynor, R. B., Sukhatme, V. P., Boone, T. C., Slamon, D. J., and Group, M. o. t. L. C. S. (1995). Expression patterns of immediate early transcription factors in human non-small cell lung cancer. The Lung Cancer Study Group. *Oncogene* 11, 1261-1269.
- Lill, N. L., Grossman, S. R., Ginsberg, D., DeCaprio, J., and Livingston, D. M. (1997). Binding and modulation of p53 by p300/CBP coactivators. *Nature* 387, 823-827.
- Lim, R. W., Varnum, B. C., and Herschman, H. R. (1987). Cloning of tetradecanoyl phorbol ester-induced 'primary response' sequences and their expression in density-arrested Swiss 3T3 cells and a TPA non-proliferative variant. *Oncogene* 1, 263-270.
- Liu, J., Grogan, L., Nau, M. M., Allegra, C. J., Chu, E., and Wright, J. J. (2001). Physical interaction between p53 and primary response gene Egr-1. *Int J Oncol* 18, 863-870.
- Matheny, C., Day, M. L., and Milbrandt, J. (1994). The nuclear localization signal of NGFI-A is located within the zinc finger DNA binding domain. *J Biol Chem* 269(11), 8176-8181.
- Milbrandt, J. (1987). Nerve growth factor-induced gene encodes a possible transcriptional regulatory factor. *Science* 238, 797-799.
- Mohiuddin, M., Ahmed, M. M., Venkatasubbarao, K., Fruitwala, S., Rangnekar, V., Cross, P., and Weinstein, M. (1997). Egr-1 expression and mutation analysis in prostate tumors. (Abstract). *Proc Amer Ass Canc Res* 38, 427.
- Nair, P., Muthukkumar, S., Sells, S. F., Han, S. S., Sukhatme, V. P., and Rangnekar, V. M. (1997). Early growth response-1-dependent apoptosis is mediated by p53. *J Biol Chem* 272, 20131-20138.
- Pavletich, N. P., and Pabo, C. O. (1991). Zinc-finger-DNA recognition: crystal structure of a Zif268-DNA complex at 2.1Å. *Science* 252, 809-817.
- Rauscher, F. J., 3rd (1993). Tumor suppressor genes which encode transcriptional repressors: studies on the EGR and Wilms' tumor (WT1) gene products. *Adv Exp Med & Biol* 348, 23-29.
- Sakaguchi, K., Herrera, J. E., Saito, S., Miki, T., Bustin, M., Vassilev, A., Anderson, C. W., and Appella, E. (1998). DNA damage activates p53 through a phosphorylation-acetylation cascade. *Genes & Development* 12, 2831-2841.
- Shikama, N., Lee, C. W., France, S., Delavaine, L., Lyon, J., Krstic-Demonacos, M., and La Thangue, N. B. (1999). A novel cofactor for p300 that regulates the p53 response. *Mol Cell* 4, 365-376.
- Silverman, E. S., Du, J., Williams, A. J., Wadgaonkar, R., Drazen, J. M., and Collins, T. (1998). cAMP-response-element-binding-protein-binding protein (CBP) and p300 are transcriptional co-activators of early growth response factor-1 (Egr-1). *Biochem J* 336 (Pt 1), 183-189.

Somasundaram, K., and El-Deiry, W. S. (1997). Inhibition of p53-mediated transactivation and cell cycle arrest by E1A through its p300/CBP-interacting region. *Oncogene 14*, 1047-1057.

Srivastava, S., Weitzmann, M. N., Kimble, R. B., Rizzo, M., Zahner, M., Milbrandt, J., Ross, F. P., and Pacifici, R. (1998). Estrogen blocks M-CSF gene expression and osteoclast formation by regulating phosphorylation of Egr-1 and its interaction with Sp-1. *J Clin Invest 102(10)*, 1850-1859.

Sukhatme, V. P., Cao, X., Chang, L. C., Tsai-Morris, C.-H., Stamenkovitch, D., Ferreira, P. C. P., Cohen, D. R., Edwards, S. A., Shows, T. B., Curran, T., *et al.* (1988). A zinc finger-encoding gene coregulated with c-fos during growth and differentiation and after cellular depolarization. *Cell 53*, 37-43.

Thigpen, A. E., Cala, K. M., Guileyardo, J. M., Molberg, K. H., McConnell, J. D., and Russell, D. W. (1996). Increased expression of early growth response-1 messenger ribonucleic acid in prostatic adenocarcinoma. *J Urol 155(3)*, 975-981.

Tsai, E. Y., Falvo, J. V., Tsytsykova, A. V., Barczak, A. K., Reimold, A. M., Glimcher, L. H., Fenton, M. J., Gordon, D. C., Dunn, I. F., and Goldfeld, A. E. (2000). A lipopolysaccharide-specific enhancer complex involving Ets, Elk-1, Sp1, and CREB binding protein and p300 is recruited to the tumor necrosis factor alpha promoter in vivo. *Mol Cell Biol 20*, 6084-6094.

Virolle, T., Adamson, E. D., Baron, V., Birle, D., Mercola, D., Mustelin, T., and de Belle, I. (2001). The Egr-1 transcription factor directly activates PTEN during irradiation-induced signalling. *Nat Cell Biol 3*, 1124-1128.

Virolle, T., Krones-Herzig, A., Baron, V., De Gregorio, G., Adamson, E. D., and Mercola, D. (2003). Egr1 promotes growth and survival of prostate cancer cells: identification of novel Egr1 target genes. *J Biol Chem 278*, 11802-11810.

APPENDIX: The Figures referred to above, follow below

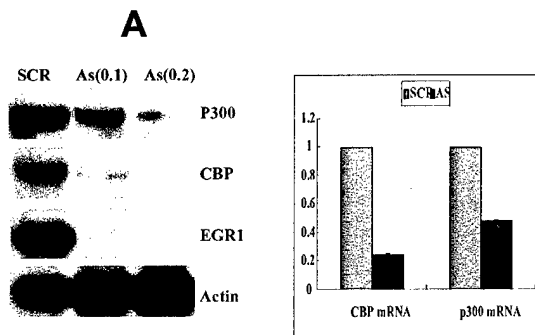
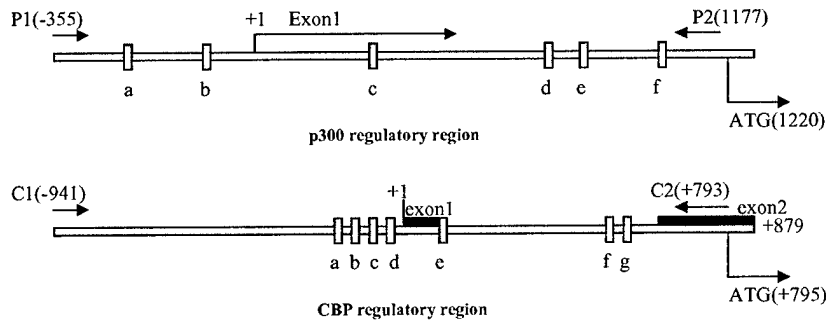

Figure 1.

(A) (B) Inhibition of Egr1 expression by anti-sense Egr1 oligos leads to inhibition of p300/CBP expression in untreated cells.

A



B

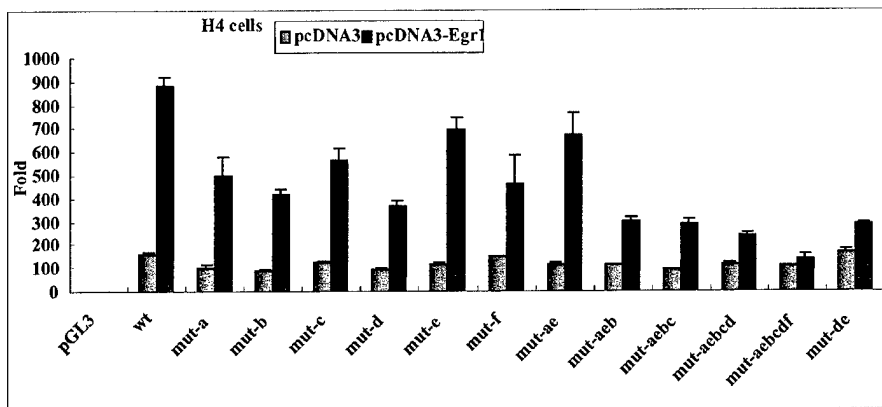

C

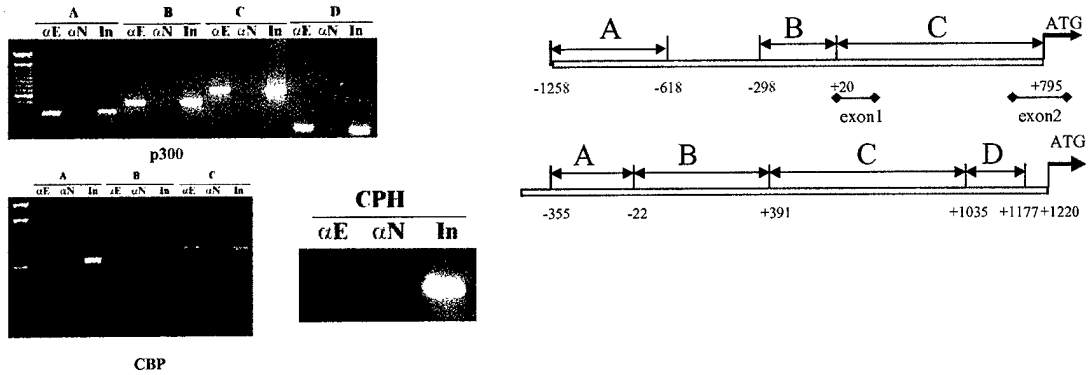
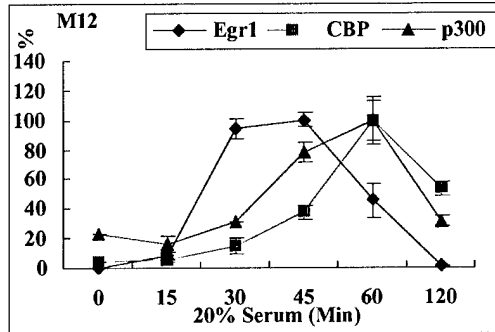
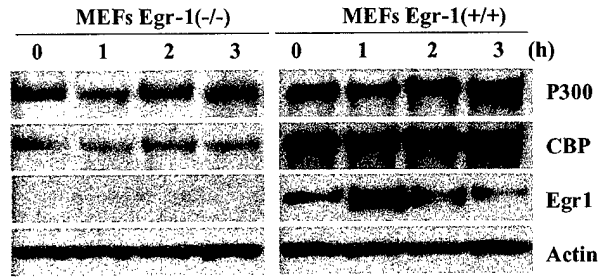

Figure 2. All six sites in the p300 promoter are regulated by Egr1 (A) Mapping the Egr1 binding sites in the CBP and p300 regulatory regions. (B) p300 promoter-Luciferase reporter is induced by Egr1 and all its Egr1 binding sites are required for full activity. (C) ChIP to confirm that Egr1 binds directly to the p300/CBP promoters in DU145 prostate cancer cells.

A



B



C

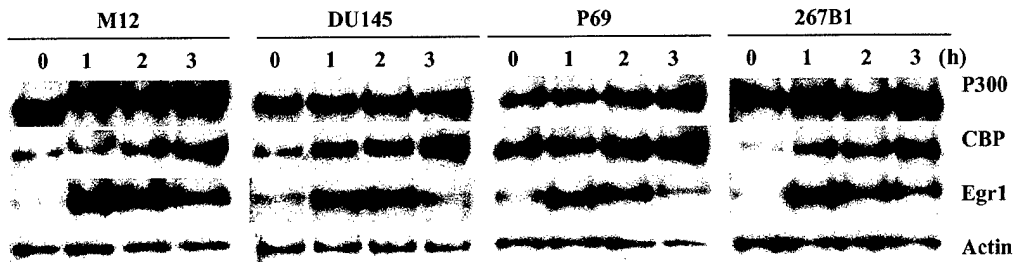
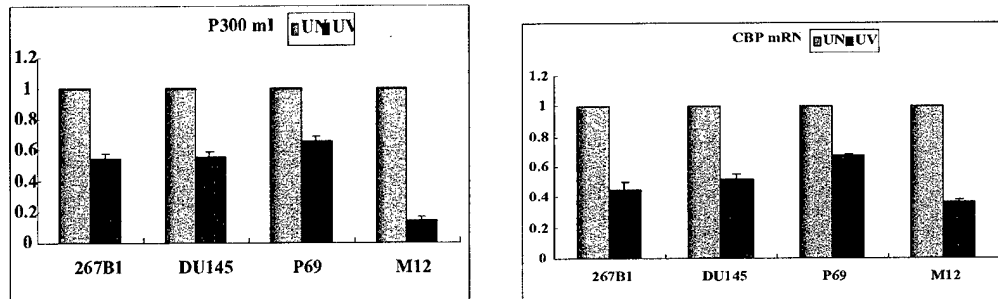
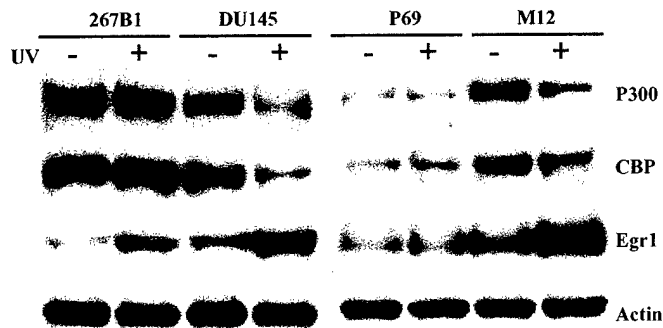

Figure 3. CBP/p300 are up-regulated by Egr1 in serum induced prostate cells and in wild-type MEFs but not Egr1^{-/-} MEFs

A



B



C

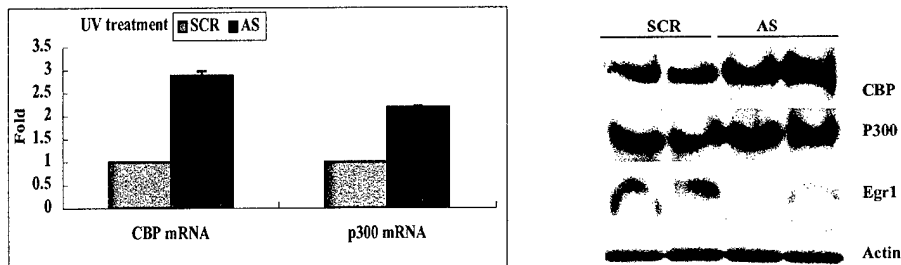
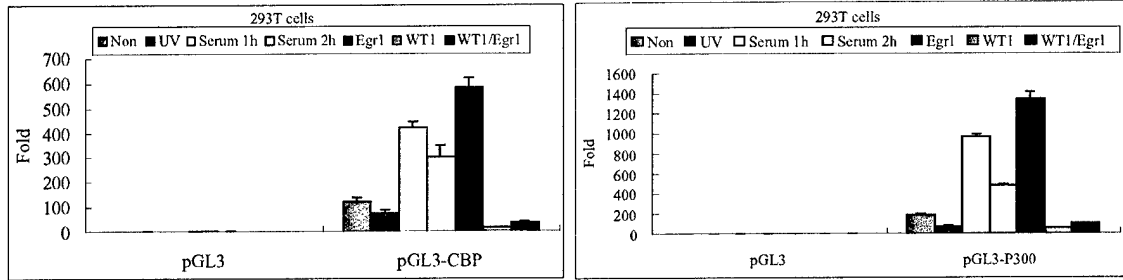
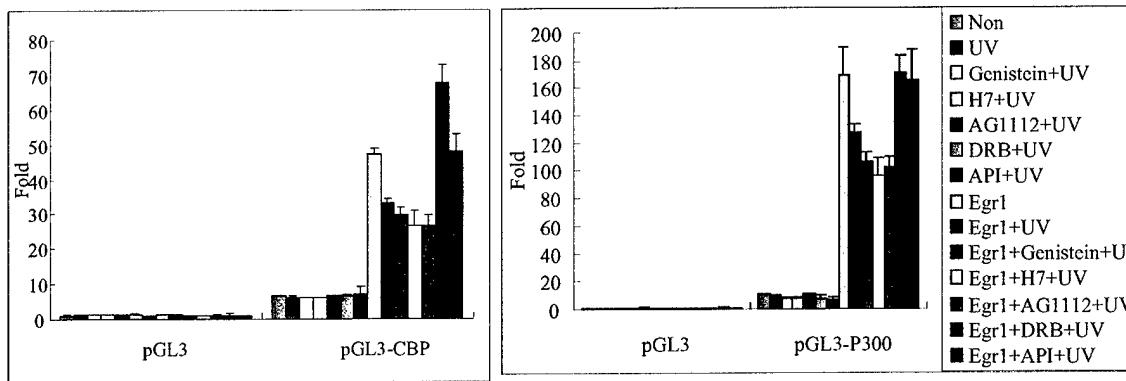

Figure 4. CBP/p300 is down regulated by Egr1 in UV irradiated prostate cancer cells.

A



B



C

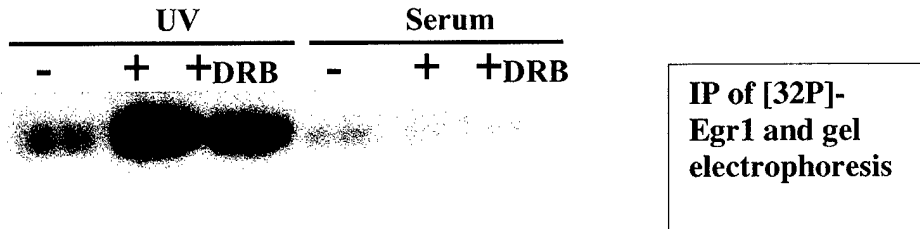

Figure 5 A, B, The activities of CBP and p300 promoters are activated by Egr-1 or serum in H4 cells, and are repressed by dominant negative Egr1 or UV. In UVC-treated cells kinase CK2 plays a role as shown by inhibitors. **C,** Radioactive ^{32}P i was used to incorporate into phosphorylated Egr1 to show that UV-C radiation increases labeling, and this is reduced by DRB, inhibitor of CK2. Serum induced Egr1 is poorly labeled and this was reduced by serum.

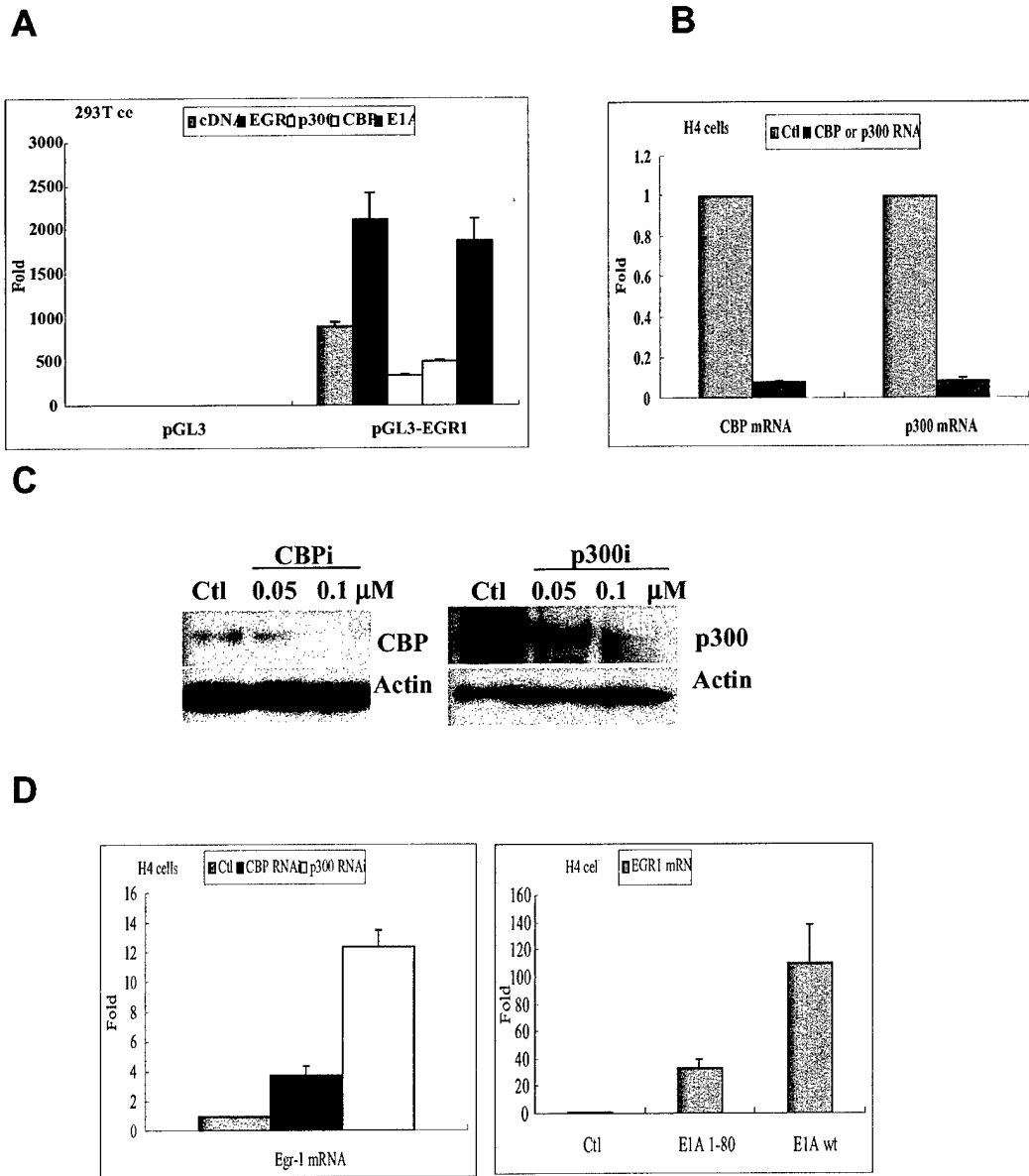
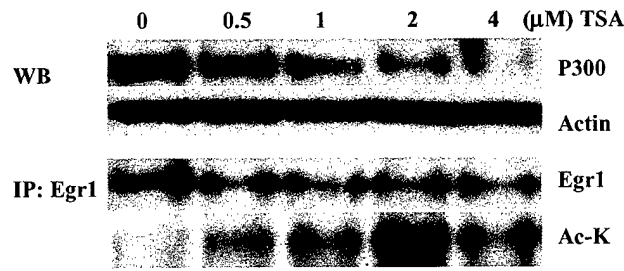
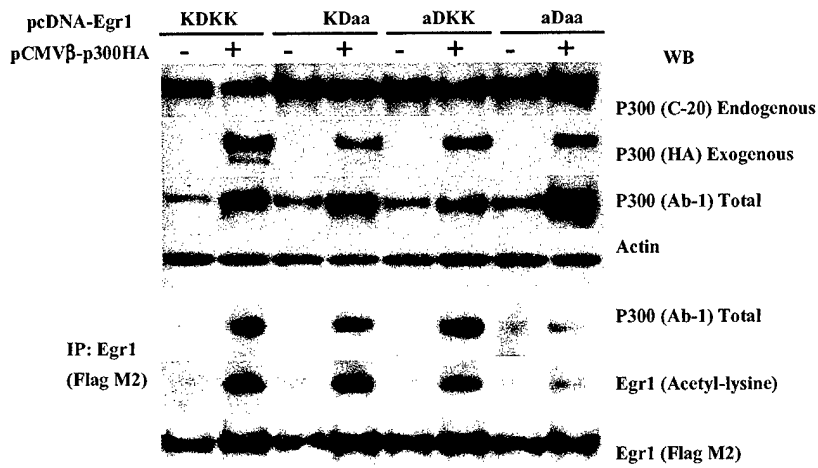

Figure 6. Feedback regulation of Egr1 transcription by Egr1 and by CBP/p300.

A



B



C

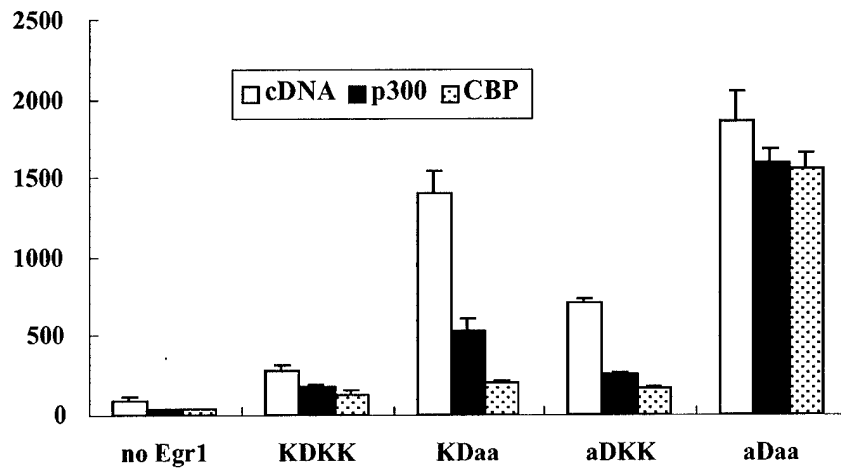
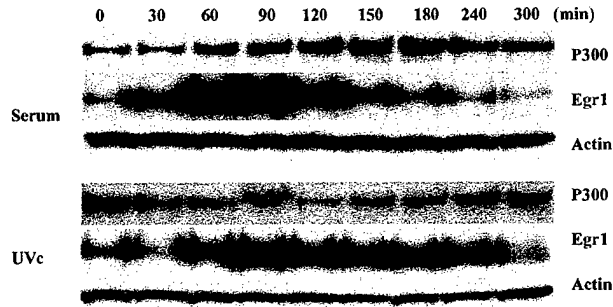
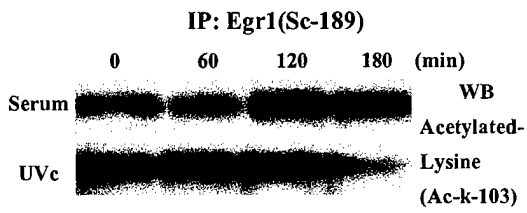

Figure 7. Egr1 can be acetylated by p300/CBP in vivo.

A



B



C

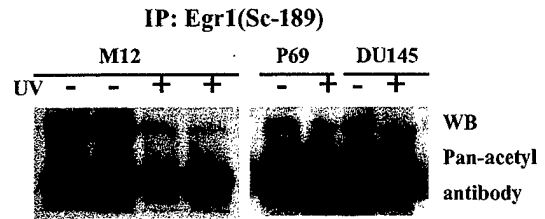

8. Acetylation of Egr1 alters its regulatory activities

A

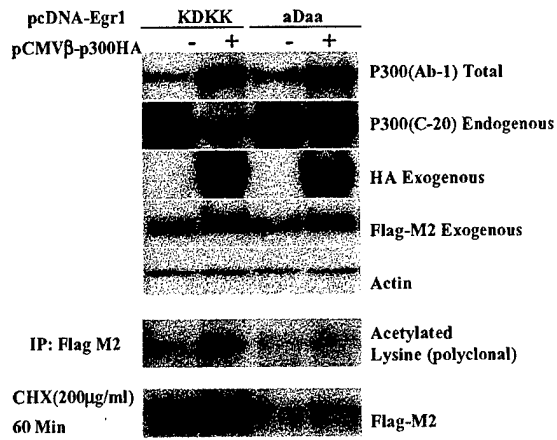

B

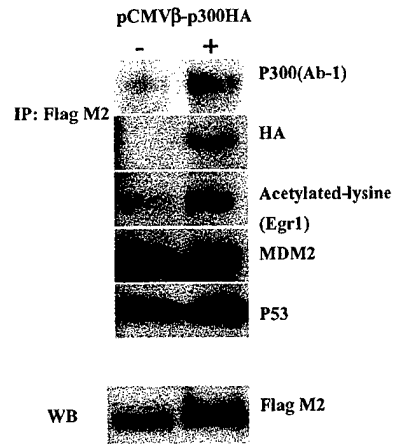
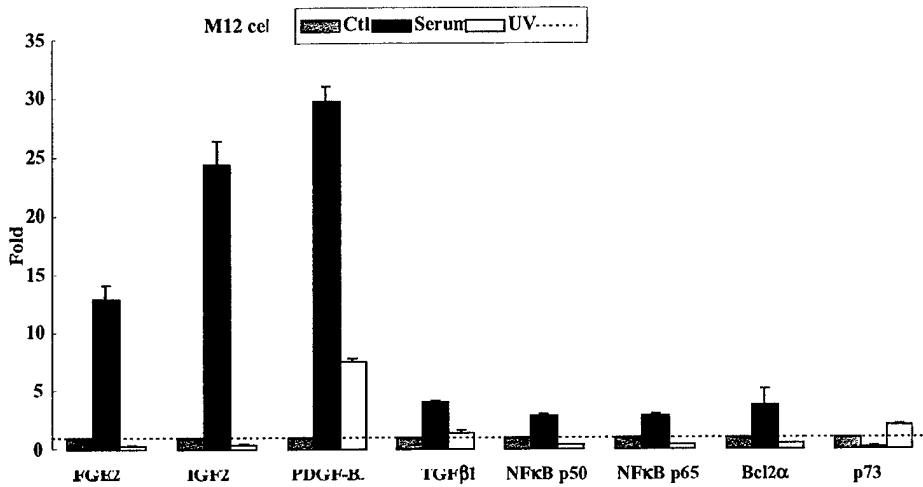
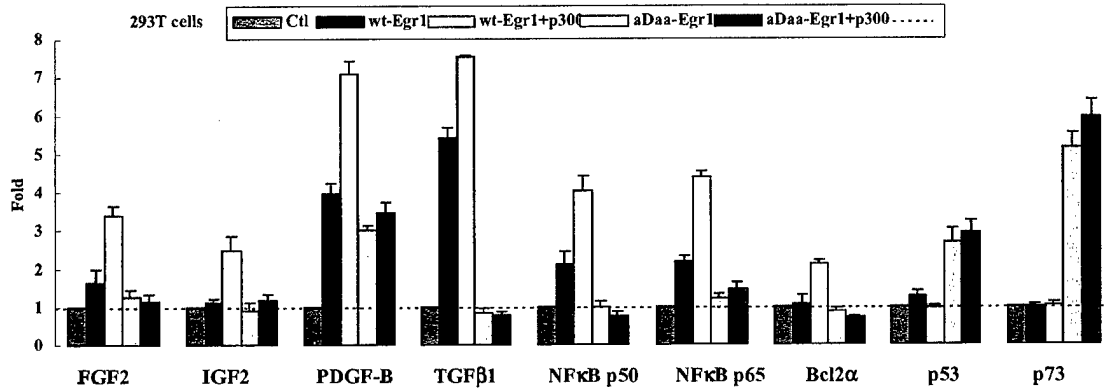

Figure 9. A, Egr1 is stabilized through acetylation by CBP/p300 and binds much more efficiently than non-acetylated.

A



B



C

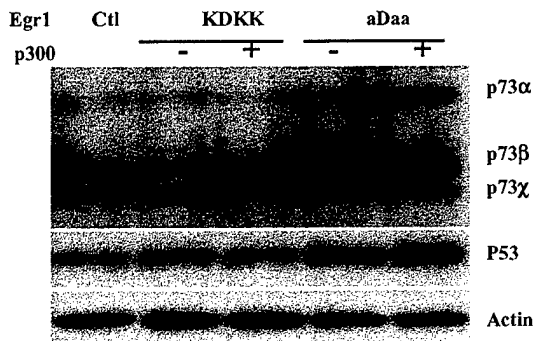

D

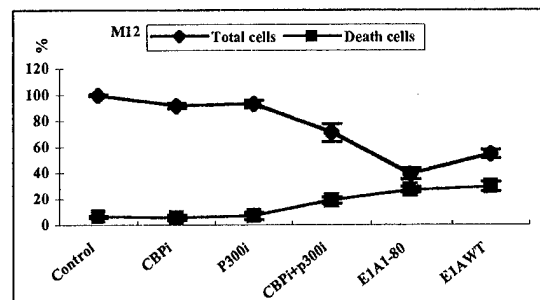

Figure 10. Egr1 target genes differ in serum-stimulated compared to UVC stimulated prostate cells. The overall biological effect of the loss p300/CBP is to reduce the acetylation and stability of Egr1 as well as alter the target genes that are regulated in M12 cells.

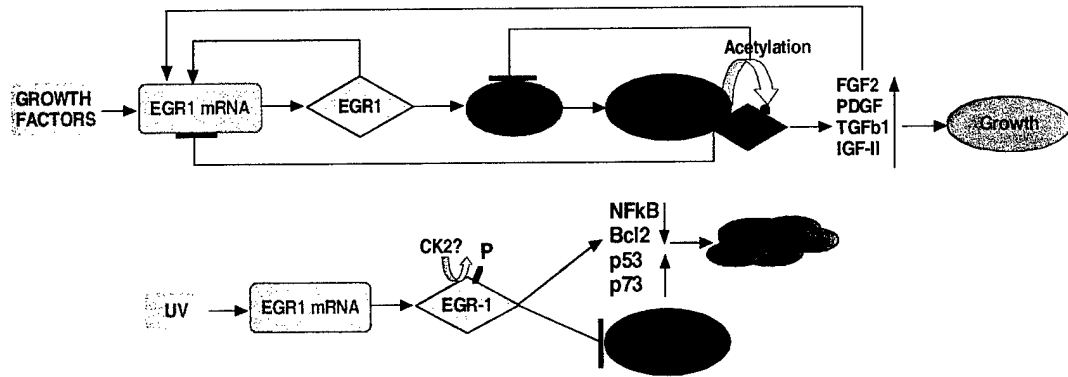

Figure 11. Schematic diagram to show interactions between Egr1 and p300/CBP