

AD_____

Award Number: DAMD17-00-1-0033

TITLE: Locating a Prostate Cancer Susceptibility Gene on the X
Chromosome by Linkage Disequilibrium Mapping Using Three
Founder Population in Quebec and Switzerland

PRINCIPAL INVESTIGATOR: William D. Foulkes, M.B., Ph.D.

CONTRACTING ORGANIZATION: Montreal General Hospital Research
Institute
Montreal, Quebec H3A 2T5
Canada

REPORT DATE: March 2004

TYPE OF REPORT: Annual

PREPARED FOR: U.S. Army Medical Research and Materiel Command
Fort Detrick, Maryland 21702-5012

DISTRIBUTION STATEMENT: Approved for Public Release;
Distribution Unlimited

The views, opinions and/or findings contained in this report are
those of the author(s) and should not be construed as an official
Department of the Army position, policy or decision unless so
designated by other documentation.

20040907 117

REPORT DOCUMENTATION PAGE

Form Approved
OMB No. 074-0188

Public reporting burden for this collection of information is estimated to average 1 hour per response, including the time for reviewing instructions, searching existing data sources, gathering and maintaining the data needed, and completing and reviewing this collection of information. Send comments regarding this burden estimate or any other aspect of this collection of information, including suggestions for reducing this burden to Washington Headquarters Services, Directorate for Information Operations and Reports, 1215 Jefferson Davis Highway, Suite 1204, Arlington, VA 22202-4302, and to the Office of Management and Budget, Paperwork Reduction Project (0704-0188), Washington, DC 20503

1. AGENCY USE ONLY (Leave blank)		2. REPORT DATE March 2004	3. REPORT TYPE AND DATES COVERED Annual (1 Mar 2003 - 28 Feb 2004)	
4. TITLE AND SUBTITLE Locating a Prostate Cancer Susceptibility Gene on the X Chromosome by Linkage Disequilibrium Mapping Using Three Founder Population in Quebec and Switzerland			5. FUNDING NUMBERS DAMD17-00-1-0033	
6. AUTHOR(S) William D. Foulkes, M.B., Ph.D.				
7. PERFORMING ORGANIZATION NAME(S) AND ADDRESS(ES) Montreal General Hospital Research Institute Montreal, Quebec H3A 2T5 Canada <i>E-Mail:</i> william.foulkes@mcgill.ca			8. PERFORMING ORGANIZATION REPORT NUMBER	
9. SPONSORING / MONITORING AGENCY NAME(S) AND ADDRESS(ES) U.S. Army Medical Research and Materiel Command Fort Detrick, Maryland 21702-5012			10. SPONSORING / MONITORING AGENCY REPORT NUMBER	
11. SUPPLEMENTARY NOTES Original contains color plates: All DTIC reproductions will be in black and white.				
12a. DISTRIBUTION / AVAILABILITY STATEMENT Approved for Public Release; Distribution Unlimited			12b. DISTRIBUTION CODE	
13. ABSTRACT (Maximum 200 Words) The funded proposal has not yet begun at all sites. We have yet to receive the SPA for the Chicoutimi site but we are confident that this will happen shortly as all the necessary documents have been sent for final review by the Army. Due to the delay with ethics approval, we applied and received a one year "no cost extension" for this proposal. At the Montreal site, 181 participants have consented to participate and their blood was drawn. We have another 32 men that have agreed to participate and their blood will be drawn in the next few months. We are continuing to ascertain new cases as via hospitals' tumor registries. We have recruited a total of 42 controls. The pedigrees for all controls and cases have been drawn. Ishihara charts were shown to all cases and controls and the results were recorded. At the Switzerland site, case ascertainment is underway. To date, four physicians have given their support to this project and we anticipate the participation of more physicians. The cancer registry in Bern has been contacted and 558 cases have been ascertained. So far 37 patients have been contacted and 30 patients consented and gave blood. Repeated contacts have led us to believe we can expect many more over the next few months.				
14. SUBJECT TERMS No Subject Terms Provided.			15. NUMBER OF PAGES 15	
			16. PRICE CODE	
17. SECURITY CLASSIFICATION OF REPORT Unclassified	18. SECURITY CLASSIFICATION OF THIS PAGE Unclassified	19. SECURITY CLASSIFICATION OF ABSTRACT Unclassified	20. LIMITATION OF ABSTRACT Unlimited	

Table of Contents

Cover.....	1
SF 298.....	2
Table of Contents.....	3
Introduction.....	4
Body.....	4
Key Research Accomplishments.....	6
Reportable Outcomes.....	6
Conclusions.....	6
References.....	
Appendices.....	7

Locating a prostate cancer susceptibility gene on the X chromosome using linkage disequilibrium mapping using three founder populations in Quebec and Switzerland.

Dr. William Foulkes

New Investigator Award: DAMD 17-00-1-0033

Introduction

In this study, we are funded to localize a prostate cancer susceptibility gene to the X chromosome (Xq) by linkage disequilibrium mapping. We plan to use three founder populations 1) French Canadian inhabitants of the Saguenay-Lac St Jean region of Quebec; 2) The Ashkenazi Jewish population of greater Montreal; 3) the population of the Swiss Canton of Valais. The DNA is also available for other prostate cancer genetic studies by the PI.

We have chosen these three populations because they have all been shown to contain founder mutations in various disease-associated genes and because they are accessible to us and have participated in research in the past.

Body of text

Task 1: Case ascertainment, contact, consent, interview, DNA extraction and pathology confirmation, years 1-3 (aim to complete in second quarter of year 3).

- Obtain approval for this study from relevant IRBs and submit appropriate documentation for review to start the project at the Chicoutimi and Switzerland sites.

In progress

The goals established in Task 1 have not yet been achieved at all sites and human subject research cannot commence at the Chicoutimi site until the Army has granted approval. Please see appendix for a full description on how we have worked to achieve this goal.

However, some of the goals have been achieved by the Sion (Switzerland) and McGill University Hospital (Quebec) sites.

- Identify all prevalent cases of prostate cancer at hospitals serving the three populations under the study.

This goal was achieved at the McGill University Hospitals last year and has been ongoing this year. 21 additional cases were ascertained since March 2003.

Because of the private health care system in Switzerland this has been a difficult and time-consuming task. 4 urologists at the Sion site have given their support to this project and ascertainment of cases has begun through these physicians. The Cancer Registry in Bern has also been contacted to ask for their support in ascertaining cases. After submitting the details regarding purpose and methods of this project, the *Commission d'experts du secret professionnel en matière de recherche médicale* in Bern granted our request to have access to their tumor registry.

We are now allowed to use nominative data from the Cancer Registry of the *Valais canton* for this project. A list of all patients diagnosed with prostate cancer between 1997 and 2002 and who are residents of the *Valais canton* was generated. Only those whose surnames indicate an origin from the *canton du Valais* were included and a total of 558 were considered eligible for this study.

- Identify incident cases through urology clinics at the three centres. Method of contact as for prevalent cases.

This goal has been achieved at the Montreal site. McGill Urology Associates are helping to identify new cases of prostate cancer.

- Consent all eligible patients.

181 patients at the McGill University Hospital sites have given their consent to participate. A total of 33 controls have given their consent to participate. A total of 38 affected men have refused to participate and none of the controls ascertained have refused to participate.

30 cases at the Sion Hospital site have given their consent to participate. There have been no controls recruited to date.

- Interview and construct three-generation pedigree for each case and control.

181 pedigrees have been drawn for cases and 33 have been drawn for controls at the McGill University Hospital site.

- Extract DNA locally at each participating centre, transfer aliquots of DNA to PI laboratory for quality check and storage.

DNA has been extracted at the McGill University Hospital and the Switzerland site. We are waiting till more cases have participated before DNA from the Sion site is transferred to the PI laboratory.

- Transfer representative slides and blocks to Montreal for central pathology review (*NB* this will take place after ascertainment as we expect few cases will be reclassified and subsequently excluded).

Slides and blocks from patients ascertained at the McGill University Hospital site have been transferred to a central pathologist for his review. The pathologist is currently reviewing material from 151 of the participating patients. Because of the pathologist's concurrent commitments this task is proceeding at a slower pace than we had anticipated. However, we expect this task to be completed by the pathologist at the end of April 2004.

We will wait for more cases to be recruited at the Sion site before the central pathologist reviews them. It would be more cost efficient to transfer these in bunches rather than a few at a time.

- Create a central database at the MGHRI.

We have developed a database at the McGill University Hospital sites and it is continually updated as more cases and controls are recruited. At the present this database holds information on cases and controls from the Montreal site only but other data from other sites will be transferred when ready.

Key Research Accomplishments

- 181 cases recruited at the Montreal site
- Review of pathology for 151 cases at the Montreal site.
- A total of 558 cases were ascertained at the Sion (Switzerland) site.
- 30 recruited at the Sion (Switzerland) site
- We have found 10% of the cases from the Montreal site to be colour blind in comparison to 8% found in other Ashkenazi populations.

Reportable Outcomes

1. Published work

Hamel et al. Founder mutations in BRCA1/2 are not frequent in Canadian Ashkenazi Jewish men with prostate cancer. *BMC Medical Genetics*. Aug, 2003.

Under review: Hope et al. Macrophage Scavenger Receptor 1 (*MSR1*) 999C>T (R293X) mutation and risk of prostate cancer. *Cancer Epidemiology Biomarker and Prevention*.

2. Conclusions

Nil

Appendix 1

Log of activities at the McGill University Hospital, Chicoutimi and Sion sites.

Abbreviations:

JGH-Sir M.B. Davis-Jewish General Hospital

MGH-Montreal General Hospital

RVH-Royal Victoria Hospital

MUHC-McGill University Health Centre

MGHRI-Montreal General Research Institute

Continued to work towards getting approval at the Chicoutimi site. March 2003-present. There has been a problem in getting a permanent Chairperson for the IRB at this site and this has stalled our completion of the SPA at this site.



Contacted the remaining physicians that had not given their support previously at the Switzerland site



We worked particularly hard to aid the Chicoutimi site with the remaining documents they are lacking. Once we received these documents will have to be translated from French to English before being sent to the US Army Material and Command.



Regular meetings have been attended with the different persons involved in the project at the Sion site.



In January 2004, upon the suggestion from the Army, we applied for a "no cost extension" and we received approval for this extension. (This was necessary due to the delay in obtaining ethics approval at the Chicoutimi site). This no cost extension was approved at the end of January 2004.



October - November 2004, we continued to request an IRB re-approval for the project from the Chicoutimi site. But we will have to wait for a permanent Chairperson to hold this position permanently



While trying to obtain the ethics for the Chicoutimi sites, we were contacting patients (approx. 150) to participate in the study at the McGill University site and the Sion site.



181 cases have donated blood and answered question about their family medical history. Ishihara charts were shown to all these patients and the results were recorded. A total of 181 pedigrees were drawn for the cases. (March 2003-February 2004). All cases previously recruited were contacted to update our database and patient information (approximately 55 cases).



33 controls consented to participate in the study. Their pedigrees were also drawn. Ishihara charts were shown to the controls and these results were recorded. (March 2003-December 2003).



During this time we continued to contact tumour registries at the McGill University Hospital sites to obtain updated lists of patients who had been diagnosed with prostate cancer.



Pathology material for 151 cases at the McGill University Hospital site was received and is currently being reviewed by a pathologist (Dr. L. Begin) to confirm the diagnosis of prostate cancer and to obtain a standard Gleason score among all cases. We are waiting for these results from Dr. L. Begin. Pathology material for an additional 30 cases has been ordered and we are waiting to receive this material before pathology review can take place.



We obtained a list of patients with a recent diagnosis of invasive prostate cancer (05-2002-05-2003) at the Sion site. Four urologists agreed to send a letter to their respective eligible patients. 558 affected men were ascertained from the Bern tumor registry and are being contacted by their physicians and the research nurse (03-2003-03-2004).



In January 2003, recruitment of patients diagnosed with prostate cancer from the *canton du Valais* began. To date, 37 patients were invited to participate. Thirty patients have agreed to participate in the study; blood sampling and DNA extraction is currently being carried out for these patients. One patient was excluded from the study.



At the McGill University site, another 32 patients have agreed to participate and we have arranged to meet most over the next three months. We anticipate more controls participating and are working actively towards recruiting many more.



We have also begun examination of prostate cancer families and hope to look more closely at a familial syndrome for prostate cancer. To date we have ascertained three prostate cancer families in our study.



We have begun to analyse the CHEK21100delC mutation in cases and controls but we only have preliminary data up to this point (March 2003-ongoing).

We have preliminary haplotype data from chromosome 7, following the publication by Friedrichsen et al, Feb 2004, Proc Natl. Acad Sci USA (February 2004-ongoing).

Research article

Open Access

Founder mutations in *BRCA1/2* are not frequent in Canadian Ashkenazi Jewish men with prostate cancer

Nancy Hamel*^{1,2}, Kimberley Kotar^{1,3} and William D Foulkes^{1,2,3}

Address: ¹Program in Cancer Genetics, Departments of Oncology and Human Genetics, McGill University, Montreal, Québec, Canada, ²Research Institute of the McGill University Health Center, McGill University, Montreal, Québec, Canada and ³Cancer Prevention Centre, Sir MB Davis, Jewish General Hospital, McGill University, Montreal, Québec, Canada

Email: Nancy Hamel* - nancy.hamel@mail.mcgill.ca; Kimberley Kotar - dolphins@colba.net; William D Foulkes - william.foulkes@mcgill.ca

* Corresponding author

Published: 11 August 2003

Received: 10 June 2003

BMC Medical Genetics 2003, 4:7

Accepted: 11 August 2003

This article is available from: <http://www.biomedcentral.com/1471-2350/4/7>

© 2003 Hamel et al; licensee BioMed Central Ltd. This is an Open Access article: verbatim copying and redistribution of this article are permitted in all media for any purpose, provided this notice is preserved along with the article's original URL.

Abstract

Background: Relatives of *BRCA1* and *BRCA2* mutation carriers have long been proposed by epidemiological studies to have an increased risk of developing prostate cancer. In the Ashkenazi Jewish (AJ) population, the existence of 3 frequent founder mutations, 185delAG and 5382insC in *BRCA1* and 6174delT in *BRCA2* greatly facilitates screening for carriers.

Methods: We tested 146 AJ men with confirmed diagnoses of invasive prostate cancer. Thirteen had at least one first degree relative with prostate cancer. The median age at diagnosis of participants was 67.9 years (range 48.6–84.2 years). Subjects were screened for the *BRCA1*:185delAG, *BRCA1*:5382insC and *BRCA2*:6174delT mutations simultaneously using a multiplex sizing assay detecting band shifts in the presence of the variant sequence.

Results: Two out of 146 individuals were found to carry the germline *BRCA2* mutation 6174delT (1.4%); the previously reported population frequency for this mutation is ~1% in AJ. We found no *BRCA1* mutations. One carrier had 2 uncles affected with prostate cancer, while the other had an uncle and daughter with breast cancer. We combined our results with previously published data examining these 3 founder AJ mutations in men with prostate cancer and in population controls. Including our results, studies to date reported 5/463 (1.1%), 2/293 (0.68%) and 7/461 (1.3%) carriers for the *BRCA1*:185delAG, *BRCA1*:5382insC and *BRCA2*:6174delT mutations in prostate cancer cases, respectively. This compares with combined reported frequencies of 85/9371 (0.91%), 24/8867 (0.27%) and 119/9514 (1.3%) for the same mutations in control individuals. There was no statistically significant excess of mutations in cases compared to controls in either gene.

Conclusions: Our observations remain preliminary. By combining all studies published to date, we have an 80% power to detect ORs of 2.7, 6.6 and 2.5 (185delAG, 5382insC and 6174 delT, respectively) while the values we observed range between 1.0 and 2.5. However, the contribution of rare mutations with such low odds ratios to the population prostate cancer burden is unlikely to be large enough to be clinically useful. Thus, contrary to suggestions from some previous epidemiological data, our observations do not support an important role for AJ founder *BRCA1/2* mutations in prostate cancer risk.

Background

Mutations in the *BRCA1* and *BRCA2* genes are responsible for a large proportion of inherited breast and ovarian cancer cases. Both *BRCA1* and *BRCA2* comprise many exons and hundreds of specific mutations have been identified to date in these 2 large genes (Breast Cancer Information Core website). This makes screening for mutations in individuals at risk a time consuming task that complicates mutation testing for large numbers of samples.

For over 2000 years, Jews have been a migratory people linked by religion, language, customs and culture, and have been establishing communities throughout the Middle East and the Mediterranean basin (reviewed in [1]). This has resulted in the creation of a Jewish genetic identity which evolved over time, partly through genetic drift and partly due to bottlenecks resulting from wars or epidemics, often followed by rapid population growth thanks to large family sizes. This genetic identity is characterized by the existence of some 40 genetic conditions with Mendelian patterns of transmission with established allele frequencies within distinct Jewish groups. In Ashkenazi Jews, two founder mutations in *BRCA1* (185delAG, population frequency ~1%, 5382insC, ~0.13%) and one founder mutation in *BRCA2* (6174delT, population frequency ~1%) [2-4], greatly facilitate screening of individuals at risk for breast and ovarian cancer.

Previous studies have suggested an increased risk of prostate cancer in relatives of *BRCA1* and *BRCA2* mutation carriers or in mutation carriers themselves [5-11]. When comparing *BRCA1* and *BRCA2* carriers in similarly designed studies, the risk of prostate cancer appears to be lower in *BRCA1* carriers [11] than in *BRCA2* carriers [10], and mostly confined to early-onset prostate cancer cases. Prostate cancer is a common malignancy, and identifying individuals at risk of developing the disease could be of clinical importance. Therefore, we attempted to determine the contribution of germ-line *BRCA1/2* mutations to the risk of prostate cancer by testing a group of unselected AJ prostate cancer cases for the 3 founder mutations.

Methods

Study Population

Following IRB approval, we used hospital-based registries to identify 435 self-reported AJ men with prevalent prostate cancer, diagnosed between 1991 and 2002, who were known to be alive in 2002. Patients were considered Ashkenazi Jewish if both parents were reported as Ashkenazi Jewish, with no Sephardic heritage. Individuals not fulfilling these criteria were excluded. All were diagnosed and/or treated in one of three large McGill University affiliated hospitals in metropolitan Montreal, Canada. The diagnosis of invasive prostate cancer was

confirmed by examining pathology reports from patients' medical charts. At the time of writing, 250 patients had been contacted (reasons for lack of contact: physician approval pending, returned unopened letters, address unknown, left town). Of these, 205 responded to our letter; 48 refused and 157 agreed to participate in the study. One-hundred-and-forty-six had provided a blood sample for this study at the time of analysis and were genotyped for two *BRCA1* and one *BRCA2* AJ founder mutations, making this the largest series of AJ prostate cancer cases studied thus far. All participants were given the option of receiving genetic counseling.

Thirteen cases had a family history (at least one first degree relative with prostate cancer) (8.9%); a single proband was included in the study from each family with multiple prostate cancer cases. The median age at diagnosis of participants was 67.9 years (range 48.6-84.2 years) and the participants were tested at a median of 5.7 years since diagnosis (range 0.3-23.7 years, 5 cases had missing information). Overall, 75/146 participants (51.4%) were found to have a Gleason score of 6/10 or greater (median number of months since diagnosis = 55) and 53/146 (36.35%) were found to have a Gleason score of 5 or less (median number of months since diagnosis = 78). This difference in the time interval between diagnosis and blood collection, dichotomized at a Gleason score of 6, is statistically significant ($P = 0.042$, Mann-Whitney U-test, 2-sided). However, when we regressed the Gleason score against the time interval in months between the date of diagnosis and blood draw, there was no evidence for an effect across all scores. The correlation coefficient (r) was -0.037 ($r^2 = 0.0013$, $P = 0.68$). We do not have a Gleason score for 18 men (12.3%, median number of months since diagnosis = 96).

Molecular Analysis

We screened for founder *BRCA1/2* mutations using a multiplex sizing assay in which all 3 PCR products can be visualized on a single polyacrylamide gel as described previously by Kuperstein et al [12]. Samples demonstrating a band shift were re-amplified and run again for confirmation. All tests included a positive control previously confirmed by sequencing.

Results and Discussion

We observed 2 *BRCA2* 6174delT mutations and no *BRCA1* mutations (Table 1). One carrier, diagnosed at age 56 with a Gleason score of 7/10, had two uncles with prostate cancer; the second carrier, diagnosed at age 76 with a Gleason score of 9/10, had no relatives with prostate cancer but had an uncle and a daughter with breast cancer (Figure 1).

Table 1: BRCA1/2 founder mutation frequencies in AJ unselected prostate cancer cases and controls

	Ref #	185delAG (%)	5382insC (%)	6174delT (%)
Cases				
Lehrer et al (1998)	13	0/60	n.t.	0/60
Hubert et al (1999)	14	2/87 (2.3%)	0/87	1/87 (1.1%)
Nastiuk et al (1999)	15	1/83 (1.2%)	n.t.	2/82 (2.4%)
Vazina et al (2000)	16	2/87 (2.3%)	2/60 (3.3%)*	1/86 (1.1%)
Hamel et al (this study)		0/146	0/146	2/146 (1.4%)
Total		5/463 (1.1%)	2/293 (0.68%)	6/461 (1.3%)
Controls				
Struewing et al (1995)	2	8/858 (0.93%)	0/433	n.t.
Roa et al (1996)	3	34/3108 (1.1%)	4/3116 (0.13%)	47/3085 (1.5%)
Oddoux et al (1996)	4	n.t.	n.t.	12/1255 (0.96%)
Struewing et al (1997)†	8	41/5318 (0.77%)	20/5318 (0.38%)	59/5087 (1.2%)
Hubert et al (1999)	14	2/87 (2.3%)	0/87	1/87 (1.1%)
Total		85/9371 (0.91%)	24/8867 (0.27%)	119/9514 (1.3%)
Overall OR (95%CI)		1.2 (0.38–2.9)	2.5 (0.29–10)	1.0 (0.37–2.4)
P Value (2-sided)		0.62	0.20	0.83

n.t. Not tested Odds ratios were calculated according to the method of Gart. 95% confidence intervals were calculated using the exact Clopper-Pearson method and P values are two-sided Fisher exact tests. *This frequency was reported as significantly different from observations in a control population in the original publication. †Data from this publication were used as control by Vazina et al, 2000.

Recent studies reporting BRCA1/2 founder mutation frequencies in unselected AJ men with prostate cancer have also failed to find an excess of carriers among affected individuals [13–15], with the exception of one study [16] where a slight but significant excess of BRCA1:5382insC carriers was observed. However, all studies were small, and lack of power may have prevented some differences from being detected. We therefore combined our results with observations in cases and, when available, controls from these studies. In addition, we compiled data from various reports which previously examined mutation frequencies in unselected AJ population controls [2–4] and AJ volunteers [8]. There were no statistically significant differences between the frequencies of the founder mutations in individuals affected with prostate cancer compared with their frequencies in AJ population controls (Table 1).

Different recruitment methods were used by the various groups cited in Table 1 as sources of controls. Hubert et al [14] selected a group of 87 healthy elderly Israeli men (median age 71 years) with no history of cancer as controls, thereby attempting to compensate for possible age-related variations in mutation frequencies. The larger populations studies [2–4] performed mutation testing on AJ individuals from either the US or Israel (or both) who were referred for unrelated genetic testing (e.g. Tay Sachs, Cystic Fibrosis, Fanconi Anemia, etc.), with no information available on gender, age or cancer history for these participants. Since genetic testing for the recessive conditions listed above would usually be undertaken prior to

making the decision of having children, this larger group is more likely to have a lower median age than that observed in prostate cancer cases. This group should, however, otherwise provide representative population frequencies for the mutations. Finally, controls from Struewing et al [8] were AJ volunteers from the Washington D.C. area who wished to participate in a study on breast and ovarian cancer. The authors acknowledge that such a recruitment scheme led to a higher than expected proportion of participants reporting a personal or family history of breast and ovarian cancer. This may conceivably result in an exaggerated mutation frequency in this control group compared to frequencies in the general population. In addition, participants in this control group included a number of siblings and relatives, including some who were mutation carriers, potentially further increasing the apparent frequency of BRCA1 and BRCA2 mutations in this cohort. We therefore compared the mutation frequencies in volunteers from the Washington D.C. area [8] to frequencies obtained from combining results from our other sources of controls [2–4,14] to determine if frequencies from the volunteer group were different from those from the general population. Frequencies for BRCA1:185delAG and BRCA2:6174delT were slightly lower in the volunteer group, although the difference was not statistically significant. In contrast, the BRCA1:5382insC mutation was significantly over-represented in volunteer controls compared to random population controls (OR = 3.3, 95%CI: 1.1–13; P = 0.02). In consequence, we compared our combined cases to controls once again, this time excluding control data from the

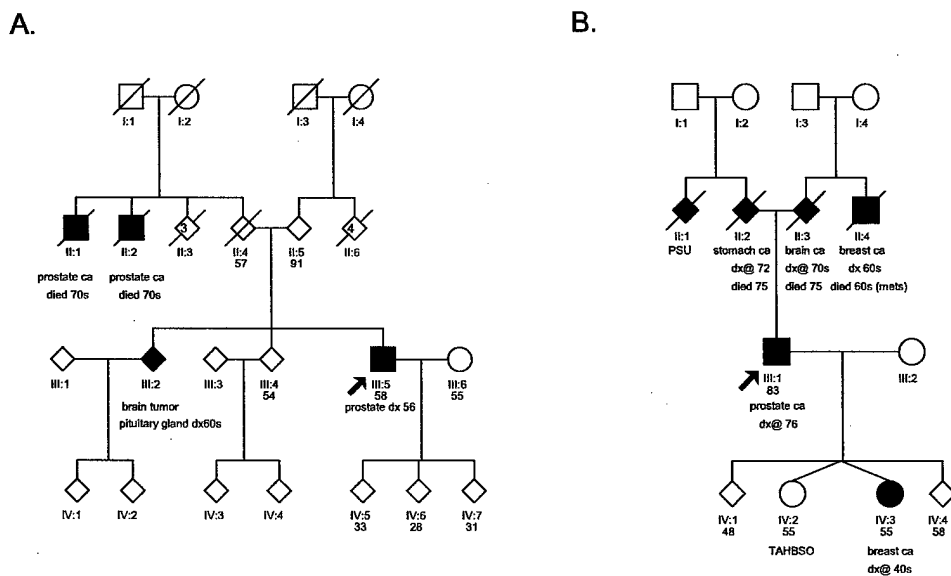

Figure 1
 Pedigrees of the 2 *BRCA2*:6174delT mutation carriers. Probands are identified with an arrow. PSU = primary site unknown; TAHBSO = total abdominal hysterectomy with bilateral salpingo-oophorectomy.

Washington D.C. study. While there was no change for *BRCA1*:185delAG and *BRCA2*:6174delT, we now observed a stronger association between the low frequency *BRCA1*:5382insC mutation and prostate cancer (OR = 6.1, 95%CI: 0.54-42; *P* = 0.07). However, as indicated by the wide confidence interval, this effect is driven entirely by 2 carriers observed by Vazina et al [16], the only report of *BRCA1*:5382insC mutations among prostate cancer cases across 3 studies. According to the authors, neither carrier has a family history of prostate cancer.

It is difficult to reconcile our observations with results from previous epidemiological studies suggesting an increased prostate cancer risk in relatives of mutation carriers [5-11]. One possible explanation may be that a diagnostic bias exists in families where hereditary cancer cases are found. Specifically, having a relative affected with

BRCA1/2-related breast or ovarian cancer may encourage relatives to undergo testing and reveal the existence of prostate tumors which may otherwise have remained asymptomatic and undetected, thereby artificially increasing the incidence of prostate cancer cases in families bearing *BRCA1/2* mutations.

If there were a significant decline in the mutation frequency of founder *BRCA1* and/or *BRCA2* mutations in older Jewish males, then it is possible that using frequencies of 0.91% for *BRCA1*:185delAG, 0.27% for *BRCA1*:5382insC and 1.3% for *BRCA2*:6174delT (Table 1) from a potentially younger population will result in an underestimation of the odds ratios observed. There are no data published that address this possibility, but if we assume that age-matched controls would have overall allele frequencies of 0.64%, 0.19% and 0.91% (observed frequencies decreased by 30%) for the 185delAG,

5382insC and 6174delT alleles, respectively, then using the cases and controls in Table 1 we still do not reach statistical significance for an association between founder mutations and prostate cancer: *BRCA1:185delAG*, OR = 1.7 ($P = 0.23$); *BRCA1:5382insC*, OR = 3.6 ($P = 0.12$); *BRCA2:6174delT*, OR = 1.4 ($P = 0.33$). Thirty percent is a generous reduction; these results suggest that a bias due to an age-related decline in mutation frequency in the control population is unlikely to be a major explanatory factor.

A third possibility is that only certain *BRCA1/2* mutations are associated with an increased prostate cancer risk. In the initial report from the Breast Cancer Linkage Consortium [10], there was a significant excess risk of prostate cancer for male *BRCA2* mutation carriers (RR: 4.65, 95% CI: 3.48–6.22). In a further analysis, Thompson et al [17] found that the risk of prostate cancer was lower in carriers of *BRCA2* mutations located in the ovarian cancer cluster region (OCCR; nucleotides 3035–6629, including the AJ founder 6174delT) than in carriers of mutations clustering elsewhere in the gene (RR = 0.52; 95%CI = 0.24–1.00; $P = 0.05$). This observation was recently indirectly supported by a large study examining 263 men with early-onset prostate cancer (55 years and less) where the authors sequenced the entire *BRCA2* coding region and found 6 truncating mutations, all located outside the OCCR [18]. However, this hypothesis cannot explain discrepancies in findings between epidemiological and direct mutation detection studies where an increased prostate cancer risk was also observed in relatives of AJ founder mutation carriers, including *BRCA2:6174delT* [9]. It is notable, however, that in the study of Warner et al. [9], a significant difference in cumulative incidence of prostate cancer to age 85 (33.6% vs. 12.6%, $P = 0.049$) was observed when comparing relatives of women with and without founder *BRCA1/2* mutations, who were themselves affected by breast cancer. Thus other factors may account for the differences in prostate cancer incidence observed.

With the combined results from nine studies, we have an 80% power to detect ORs of 2.7, 6.6 and 2.5 (185delAG, 5382insC and 6174 delT, respectively), while the values we observed range between 1.0 and 2.5. Therefore, we do not have the power to rule out small effects even with our combined sample size. For a mutation with a population frequency near 1%, we would need more than 3,200 cases and 3,200 controls to rule out an OR of 2.0 or greater; over 10,000 cases and 10,000 controls would be needed to exclude an OR of 1.5 or greater. These numbers indicate that larger studies will be needed to rule out a small effect by *BRCA1/2* founder mutations on prostate cancer risk. However, using the observed mutation frequency in con-

trols, we can estimate the population attributable risk per cent (PAR%) of these mutations as follows:

$$\text{PAR\%} = P_e (\text{RR}-1) / [1 + P_e (\text{RR}-1)] \times 100$$

where P_e = proportion of exposure in controls and RR = observed relative risk between cases and controls. PAR% values will reflect the proportion of prostate cancer cases attributable to these AJ founder mutations based on their frequency in the population; from the combined data in Table 1, these values are 0.18% (*BRCA1:185delAG*), 0.40% (*BRCA1:5382insC*) and 0% (*BRCA2:6174delT*). In comparison, based on previously published data on cases diagnosed after 55 years of age [19,20], the PAR% of AJ *BRCA1* (185delAG and 5382insC combined) and *BRCA2* (6174delT) founder mutations are 3.8% and 2.5 %, respectively, in the case of breast cancer, and 23.8% and 16.7%, respectively, in the case of ovarian cancer.

Conclusions

We screened 146 AJ men with prostate cancer for germline AJ *BRCA1/2* founder mutations, and found only two carriers of the *BRCA2:6174delT* mutation. As was the case in previous smaller studies, our observations failed to support previous data suggesting that AJ founder *BRCA1/2* mutations might contribute significantly to prostate cancer risk. While even the combined results of publications to date do not have the power to rule out a small effect, PAR percentages above do not support a major role for these founder mutations in prostate cancer susceptibility. Any modest but statistically significant contribution of these three mutations to prostate cancer risk that may be uncovered using larger studies is unlikely to be of clinical significance.

Electronic Database

Breast Cancer Information Core: <http://research.nhgri.nih.gov/bic/>

Authors' Contribution

NH carried out the molecular genetic studies, the statistical analyses and drafted the manuscript. KK recruited the participants and collected all epidemiological information in Montreal. WDF designed and coordinated the study and contributed to drafting the manuscript. All authors read and approved the final manuscript.

Acknowledgements

Funded by the Department of Defense (DAMD17-00-1-0033) the Canadian Genetic Diseases Network and the National Institutes of Health. We thank McGill University urologists- Drs. A Aprikian, J Corcos, M. Elhilali, Y Taguchi and S Tanguay for help with recruitment.

References

- Ostrer H: **A genetic profile of contemporary Jewish populations.** *Nat Rev Genet* 2001, 2:891-898.

2. Struewing JP, Abeliovich D, Peretz T, Avishai N, Kaback MM, Collins FS and Brody LC: **The carrier frequency of the BRCA1 185delAG mutation is approximately 1 percent in Ashkenazi Jewish individuals.** *Nat Genet* 1995, **11**:198-200.
3. Roa BB, Boyd AA, Volcik K and Richards CS: **Ashkenazi Jewish population frequencies for common mutations in BRCA1 and BRCA2.** *Nat Genet* 1996, **14**:185-187.
4. Oddoux C, Struewing JP, Clayton CM, Neuhausen S, Brody LC, Kaback M, Haas B, Norton L, Borgen P, Jhanwar S, Goldgar D, Ostrer H and Offit K: **The carrier frequency of the BRCA2 6174delT mutation among Ashkenazi individuals is approximately 1 percent.** *Nat Genet* 1996, **14**:188-190.
5. Ford D, Easton DF, Bishop DT, Narod SA and Goldgar DE: **Risks of cancer in BRCA1-mutation carriers.** *Breast Cancer Linkage Consortium.* *Lancet* 1994, **343**:692-695.
6. Easton DF, Steele L, Fields P, Ormiston W, Averill D, Daly PA, McManus R, Neuhausen SL, Ford D, Wooster R, Cannon-Albright LA, Stratton MR and Goldgar DE: **Cancer risks in two large breast cancer families linked to BRCA2 on chromosome 13q12-13.** *Am J Hum Genet* 1997, **61**:120-128.
7. Sigurdsson S, Thorlacius S, Tomasson J, Tryggvadottir L, Benediktsdottir K, Eyfjord JE and Jonsson E: **BRCA2 mutation in Icelandic prostate cancer patients.** *J Mol Med* 1997, **75**:758-761.
8. Struewing JP, Hartge P, Wacholder S, Baker SM, Berlin M, McAdams M, Timmerman MM, Brody LC and Tucker MA: **The risk of cancer associated with specific mutations of BRCA1 and BRCA2 among Ashkenazi Jews.** *N Engl J Med* 1997, **336**:1401-1408.
9. Warner E, Foulkes W, Goodwin P, Meschino W, Blondal J, Paterson C, Ozcelik H, Goss P, Allingham-Hawkins D, Hamel N, Di Prospero L, Contiga V, Serruya C, Klein M, Moslehi R, Honeyford J, Liede A, Glendon G, Brunet JS and Narod S: **Prevalence and penetrance of BRCA1 and BRCA2 gene mutations in unselected Ashkenazi Jewish women with breast cancer.** *J Natl Cancer Inst* 1999, **91**:1241-1247.
10. The Breast Cancer Linkage Consortium: **Cancer risks in BRCA2 mutation carriers.** *J Natl Cancer Inst* 1999, **91**:1310-1316.
11. Thompson D, Easton DF and The Breast Cancer Linkage Consortium: **Cancer incidence in BRCA1 mutation carriers.** *J Natl Cancer Inst* 2002, **94**:1358-1365.
12. Kuperstein G, Foulkes WD, Ghadirian P, Hakimi J and Narod SA: **A rapid fluorescent multiplexed-PCR analysis (FMPA) for founder mutations in the BRCA1 and BRCA2 genes.** *Clin Genet* 2000, **57**:213-220.
13. Lehrer S, Fodor F, Stock RG, Stone NN, Eng C, Song HK and McGovern M: **Absence of 185delAG mutation of the BRCA1 gene and 6174delT mutation of the BRCA2 gene in Ashkenazi Jewish men with prostate cancer.** *Br J Cancer* 1998, **78**:771-773.
14. Hubert A, Peretz T, Manor O, Kaduri L, Wienberg N, Lerer I, Sagi M and Abeliovich D: **The Jewish Ashkenazi founder mutations in the BRCA1/BRCA2 genes are not found at an increased frequency in Ashkenazi patients with prostate cancer.** *Am J Hum Genet* 1999, **65**:921-924.
15. Nastiuk KL, Mansukhani M, Terry MB, Kularatne P, Rubin MA, Melamed J, Gammon MD, Ittmann M and Krolewski JJ: **Common mutations in BRCA1 and BRCA2 do not contribute to early prostate cancer in Jewish men.** *Prostate* 1999, **40**:172-177.
16. Vazina A, Baniel J, Yaacobi Y, Shtriker A, Engelstein D, Leibovitz I, Zehavi M, Sidi AA, Ramon Y, Tischler T, Livne PM and Friedman E: **The rate of the founder Jewish mutations in BRCA1 and BRCA2 in prostate cancer patients in Israel.** *Br J Cancer* 2000, **83**:463-466.
17. Thompson D and Easton D: **Variation in cancer risks, by mutation position, in BRCA2 mutation carriers.** *Am J Hum Genet* 2001, **68**:410-419.
18. Edwards SM, Kote-Jarai Z, Meitz J, Hamoudi R, Hope Q, Osin P, Jackson R, Southgate C, Singh R, Falconer A, Dearnaley DP, Ardern-Jones A, Murkin A, Dowe A, Kelly J, Williams S, Oram R, Stevens M, Teare DM, Ponder BA, Gayther SA, Easton DF and Eeles RA: **Two percent of men with early-onset prostate cancer harbor germline mutations in the BRCA2 gene.** *Am J Hum Genet* 2003, **72**:1-12.
19. Satagopan JM, Offit K, Foulkes W, Robson ME, Wacholder S, Eng CM, Karp SE and Begg CB: **The lifetime risks of breast cancer in Ashkenazi Jewish carriers of BRCA1 and BRCA2 mutations.** *Cancer Epidemiol Biomarkers Prev* 2001, **10**:467-473.
20. Satagopan JM, Boyd J, Kauff ND, Robson M, Scheuer L, Narod S and Offit K: **Ovarian cancer risk in Ashkenazi Jewish carriers of**

BRCA1 and BRCA2 mutations. *Clin Cancer Res* 2002, **8**:3776-3781.

Pre-publication history

The pre-publication history for this paper can be accessed here:

<http://www.biomedcentral.com/1471-2350/4/7/prepub>

Publish with **BioMed Central** and every scientist can read your work free of charge

"BioMed Central will be the most significant development for disseminating the results of biomedical research in our lifetime."

Sir Paul Nurse, Cancer Research UK

Your research papers will be:

- available free of charge to the entire biomedical community
- peer reviewed and published immediately upon acceptance
- cited in PubMed and archived on PubMed Central
- yours — you keep the copyright

Submit your manuscript here:
http://www.biomedcentral.com/info/publishing_adv.asp

