



Magnetically-Controlled Electroslag Melting (MEM) of Multicomponent Titanium Alloys

Y.Y. KOMPAN

The E. O. Paton Electric Welding Institute, Ukraine

NATO ARW Metallic Materials with High Structural Efficiency

Kyiv, 2003

Report Documentation Page

*Form Approved
OMB No. 0704-0188*

Public reporting burden for the collection of information is estimated to average 1 hour per response, including the time for reviewing instructions, searching existing data sources, gathering and maintaining the data needed, and completing and reviewing the collection of information. Send comments regarding this burden estimate or any other aspect of this collection of information, including suggestions for reducing this burden, to Washington Headquarters Services, Directorate for Information Operations and Reports, 1215 Jefferson Davis Highway, Suite 1204, Arlington VA 22202-4302. Respondents should be aware that notwithstanding any other provision of law, no person shall be subject to a penalty for failing to comply with a collection of information if it does not display a currently valid OMB control number.

1. REPORT DATE 18 MAR 2004	2. REPORT TYPE N/A	3. DATES COVERED -	
4. TITLE AND SUBTITLE Magnetically-Controlled ElectroslagMelting (MEM) of MulticomponentTitanium Alloys		5a. CONTRACT NUMBER	
		5b. GRANT NUMBER	
		5c. PROGRAM ELEMENT NUMBER	
6. AUTHOR(S)		5d. PROJECT NUMBER	
		5e. TASK NUMBER	
		5f. WORK UNIT NUMBER	
7. PERFORMING ORGANIZATION NAME(S) AND ADDRESS(ES) The E. O. Paton Electric Welding Institute,Ukraine		8. PERFORMING ORGANIZATION REPORT NUMBER	
9. SPONSORING/MONITORING AGENCY NAME(S) AND ADDRESS(ES)		10. SPONSOR/MONITOR'S ACRONYM(S)	
		11. SPONSOR/MONITOR'S REPORT NUMBER(S)	
12. DISTRIBUTION/AVAILABILITY STATEMENT Approved for public release, distribution unlimited			
13. SUPPLEMENTARY NOTES See also ADM001672., The original document contains color images.			
14. ABSTRACT			
15. SUBJECT TERMS			
16. SECURITY CLASSIFICATION OF:			17. LIMITATION OF ABSTRACT
a. REPORT NATO/unclassified	b. ABSTRACT unclassified	c. THIS PAGE unclassified	UU
			18. NUMBER OF PAGES 25
			19a. NAME OF RESPONSIBLE PERSON

Thus, at the present time it is not so important **only** to develop new alloys, but **also** special methods and processes of melting which guarantee reproducibility of their properties.

Here, the degree of chemical and structural homogeneity of metal is so much important characteristic that its improvement should be considered as one of priority trends in the development of the melting technology.

Technological advantages of electroslag process is:

- Comparatively low-temperature, non-concentrated heat source
 - Simplicity and reliability of used equipment
 - Flexibility of technological parameters of melting
 - High quality of surface of ingots
 - Feasibility of producing ingots of various cross-section
-
-

Principle of magnetic control consists in interaction of external magnetic field with electrical current of melting. As a result of this interaction, the volume electromagnetic forces f_e are formed in a current-carrying metallurgical melt, which in their turn cause the melt movement.

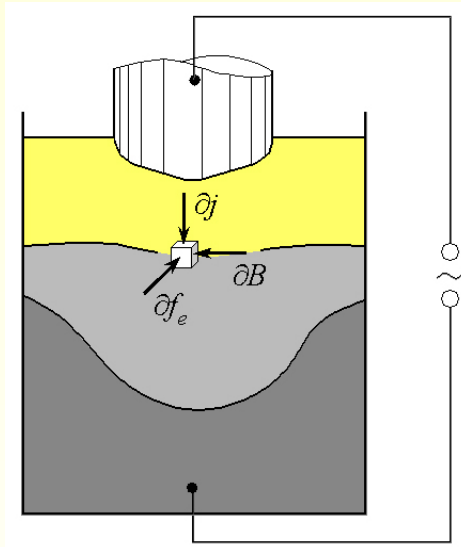

$$\vec{f}_e = \vec{j} \times \vec{B}, \quad \text{rot } \vec{f}_e \neq 0$$

where - \vec{f}_e is the electromagnetic force,

- \vec{j} is the density of melting current,

- \vec{B} is the induction of magnetic field.

One of the main task of the technology of the *Magnetically-Controlled Electroslag Melting (MEM)* is the control of processes of melting, transfer and crystallization of metal by creating various trajectories of movement of the metallurgical melt.

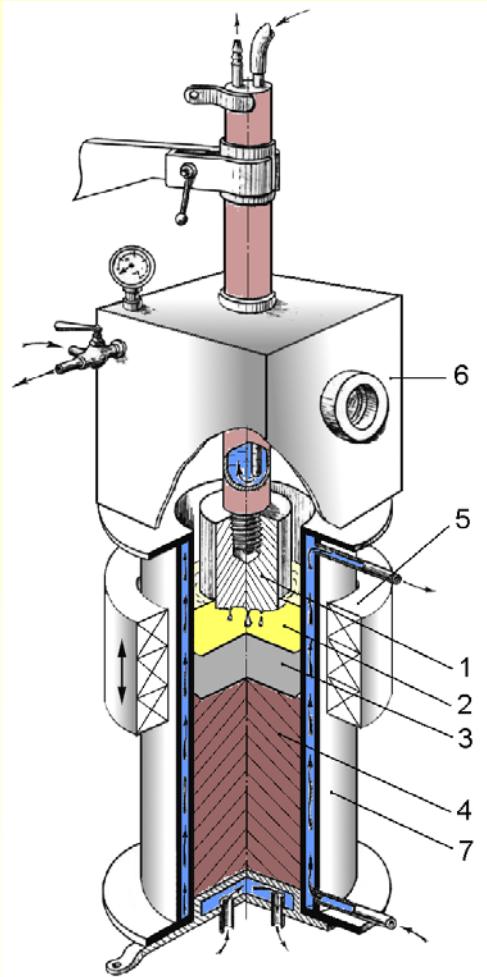

MEM of titanium alloys is realized in a pressurized electroslag chamber-type furnace. The melting space is preliminary evacuated, and then filled with an inert gas.

Scheme of MEM process:

*1 - electrode, 2 - slag pool,
3 - metal pool, 4 - ingot,
5 - electromagnetic system,
6 - vacuum chamber, 7 - mould.*

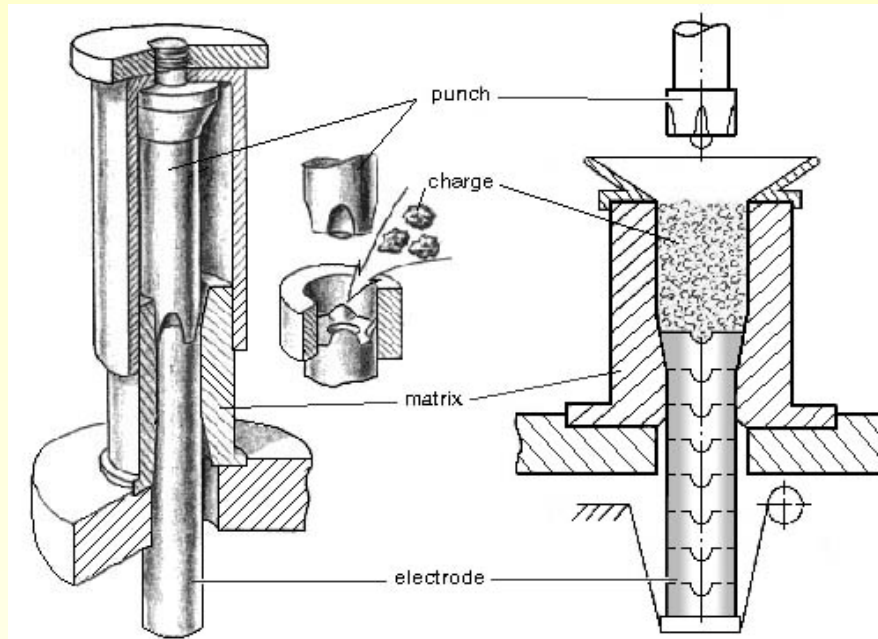

Scheme of electrode pressing



Consumable pressed electrodes for MEM

MEM methods of titanium alloys

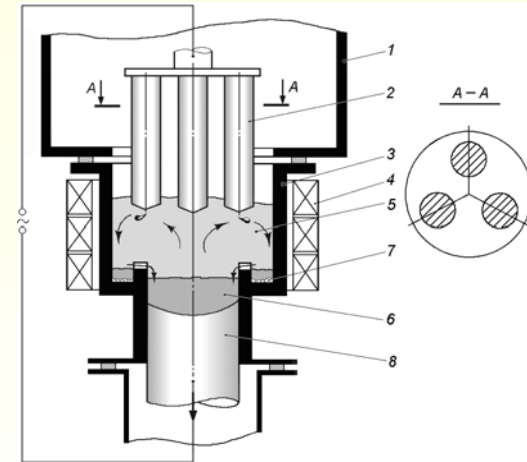
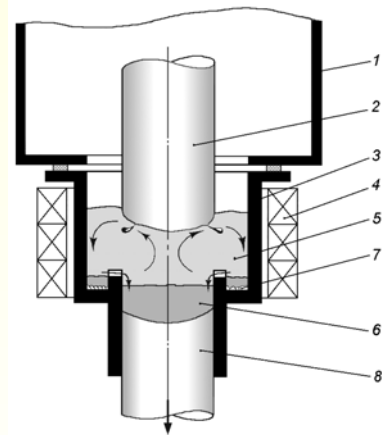
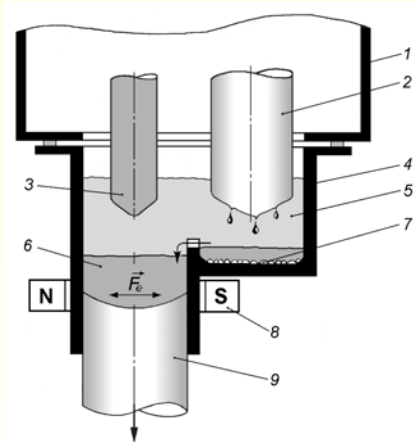
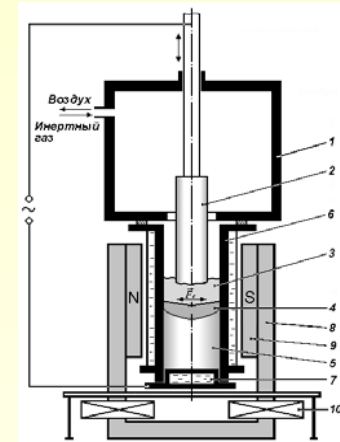
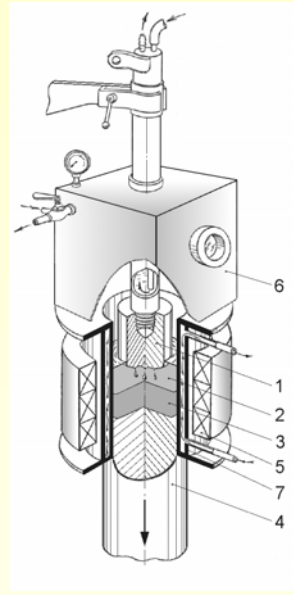
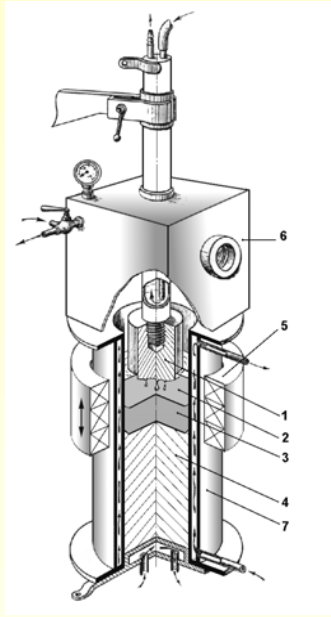

Mechanisms of electromagnetic control :

- Creation of directed Electroconvective Flows (ECF) in the metallurgical pool
- Creation of reciprocating oscillations (vibration) of the melt

To prevent the chemical and structural heterogeneity of the metal in electroslag melting, it is necessary to provide:

- *The uniform heat input into the metallurgical pool*
- *Intensive stirring of the metallurgical melt*
- *Formation of shallow metal pool with a steep front of crystallization.*

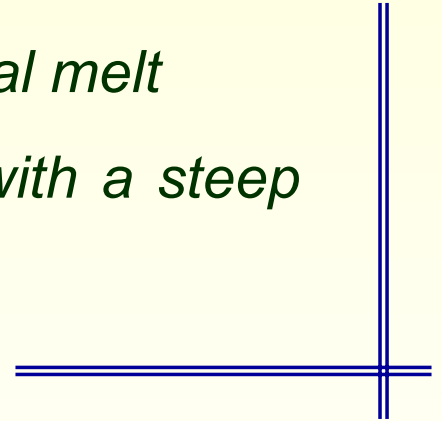

Melt motion direction during traditional ESR

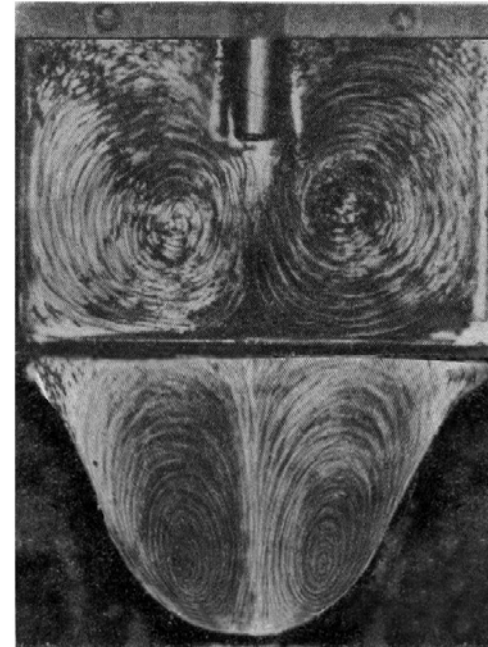
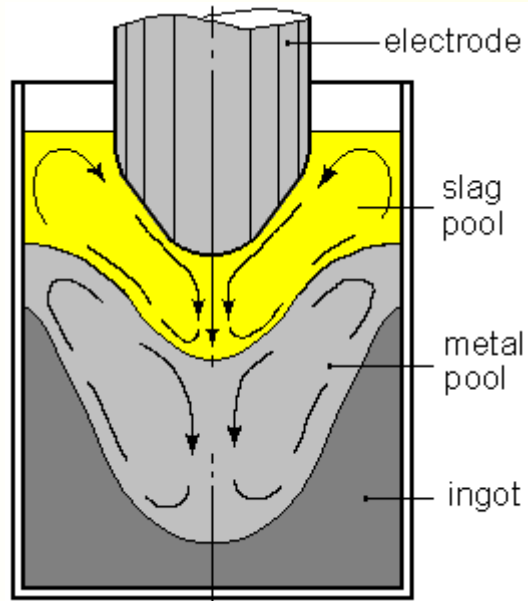

*Shape of metal
pool during
traditional ESR*



*Macrostructure of
ingot Ti – 33%Al
ESR*



Electrovortical flows during melting in longitudinal magnetic field

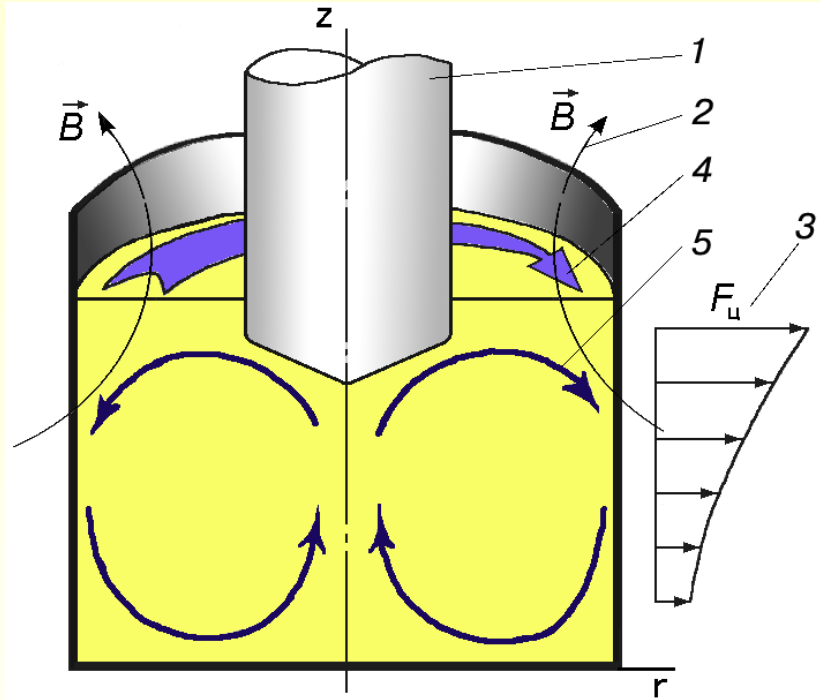

- 1 – consumable electrode,
- 2 – lines of magnetic field,
- 3 – centrifugal force,
- 4 – slag flows in horizontal plane,
- 5 – slag flows in vertical plane.

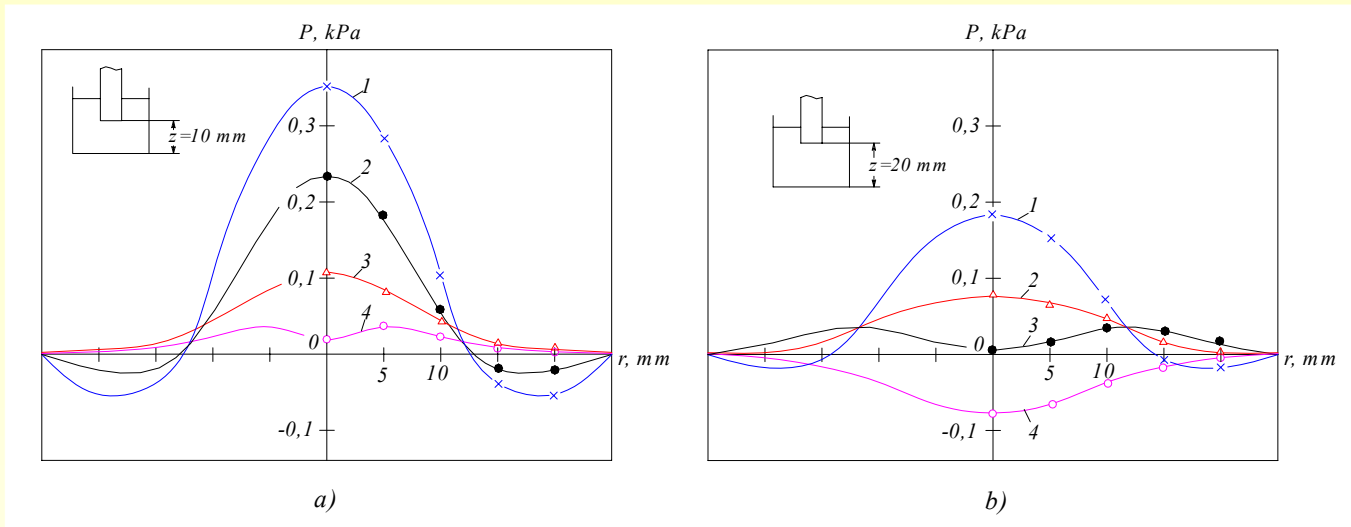

Distribution of pressure to metal pool surface at $z = 10$ mm (a) and $z = 20$ mm (b) for different values of induction of longitudinal magnetic field B_z :
 1 – 0 mT; 2 – 7 mT; 3 – 13 mT; 4 – 20 mT.

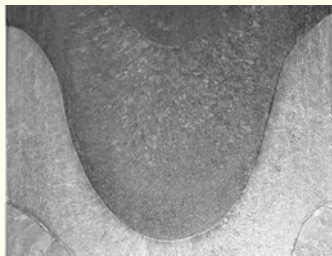

a

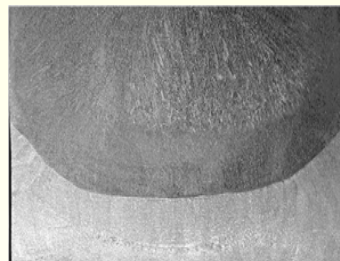

b

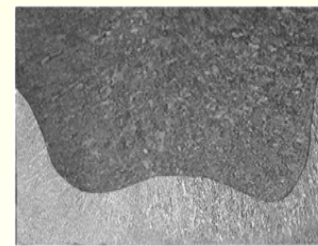

c

Shape of metal pool during melting in longitudinal magnetic field:
a – $B = 0$ T; **b** – $B = 0,06$ T; **c** – $B = 0,1$ T.

Scheme of melting in longitudinal-radial magnetic field envisages the creation of at least two radial fields of opposite direction in slag and metal pools, respectively. This will result in the formation of opposite flows in slag and metal pools, which activate the interaction at the slag-metal interface and promotes the improvement of homogeneity of the metal.

Rotation of slag increases the trajectories and period of movement of inclusions in the melt, thus increasing the effectiveness of their dissolution. The melting is performed mainly in the stationary mould with a movable electromagnetic system.

Electrovortical flows during melting in longitudinal-radial magnetic field

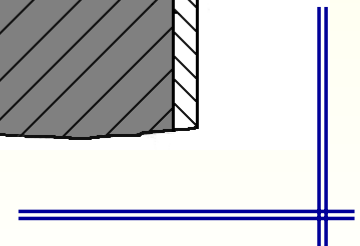
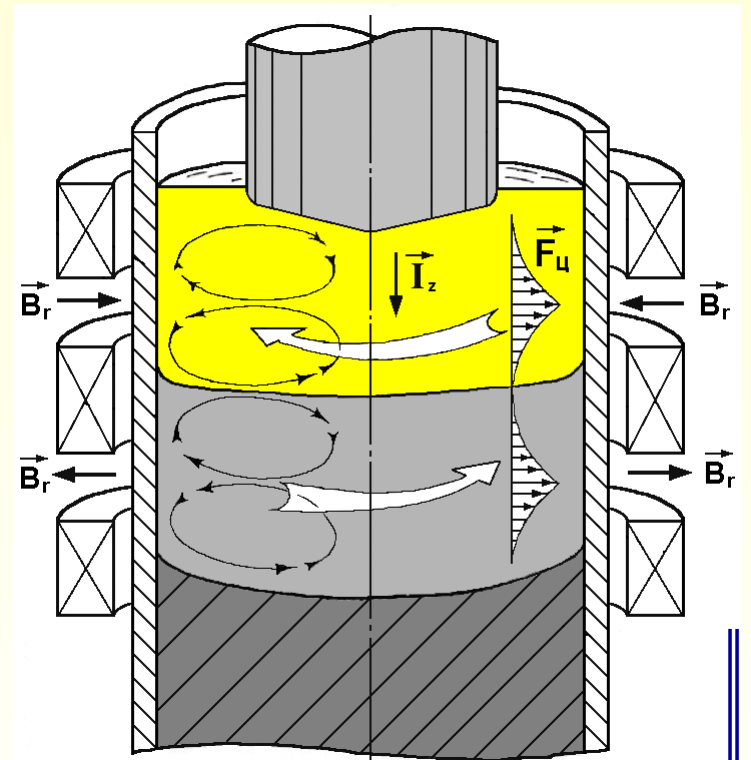

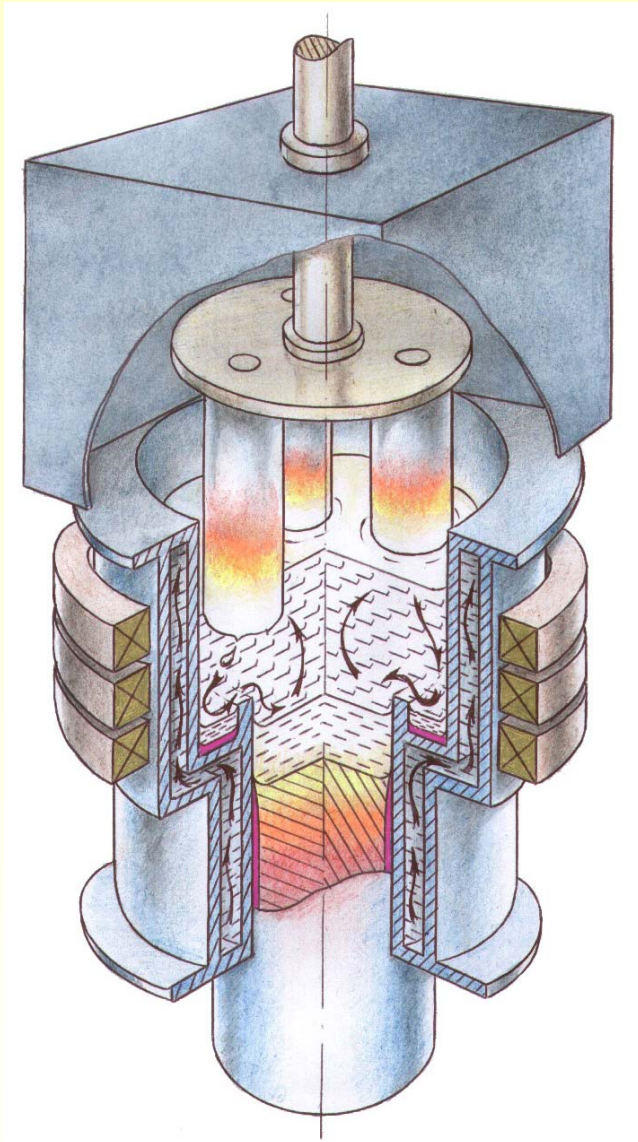

*Scheme of melting in
T-shaped mould using
“split electrode”*

Better control of heat and mass transfer during melting is achieved by melting in T-shaped mould, as shown in Figure. In this case the intensive stirring created in the melt extends over the entire volume of the pool.

Thus, directed electrovortical flows **allow**:

- To control depth and shape of metal pool
- Equalize the temperature field of the pool
- Intensify heat- and mass exchange in the metallurgical pool

and as a result they contribute to the formation of metal with a high chemical and structural homogeneity.

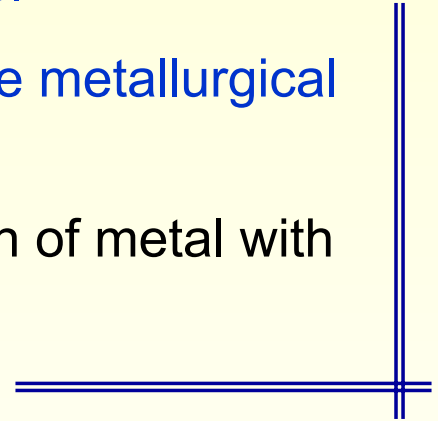

Scheme of MEM in transversal magnetic field

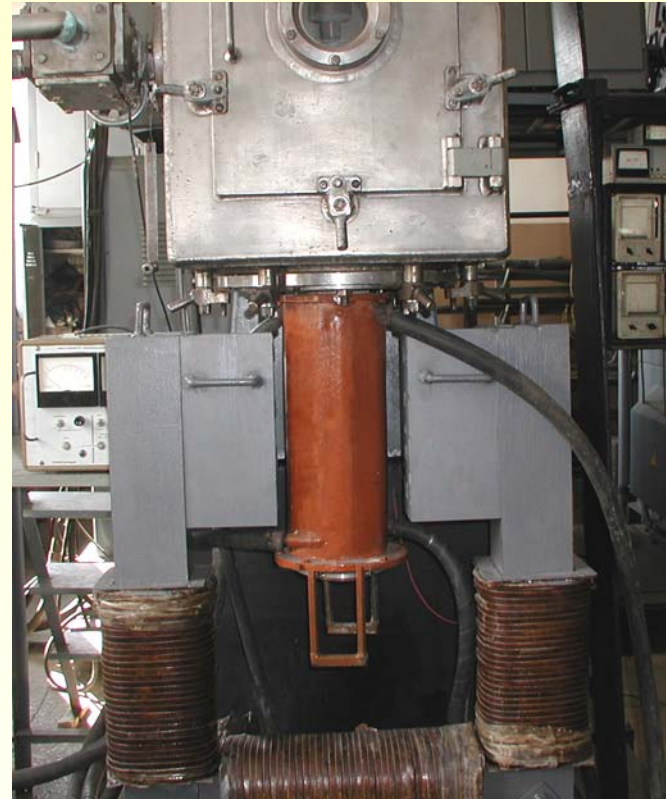
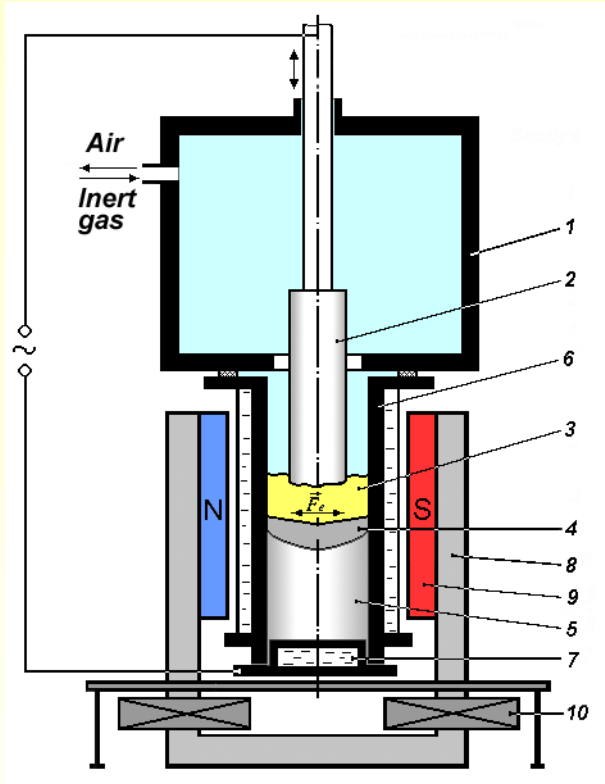

1 - vacuum chamber, 2 - electrode, 3 - slag pool, 4 - metal pool, 5 - ingot, 6 - mould, 7 - bottom, 8 - magnetic circuit, 9 - magnet poles, 10 - electromagnet coils.

*End of consumable
electrode*



$$h_{\text{pool}} = 0,3 \times D_{\text{ingot}}$$

*Shape of metal pool during
melting in transversal magnetic
field*



Macrostructure of ingots of *Ti-10V-2Fe-3Al* alloy

without magnetic control

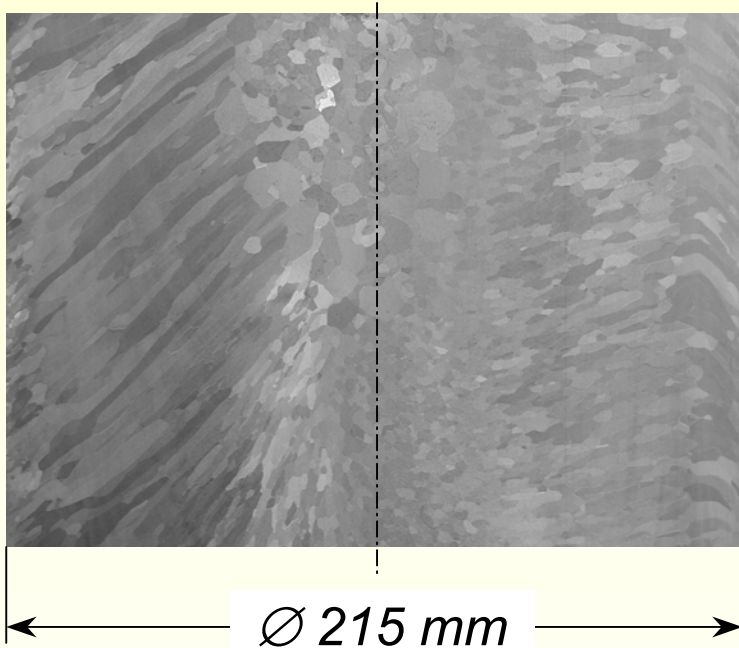

with magnetic control

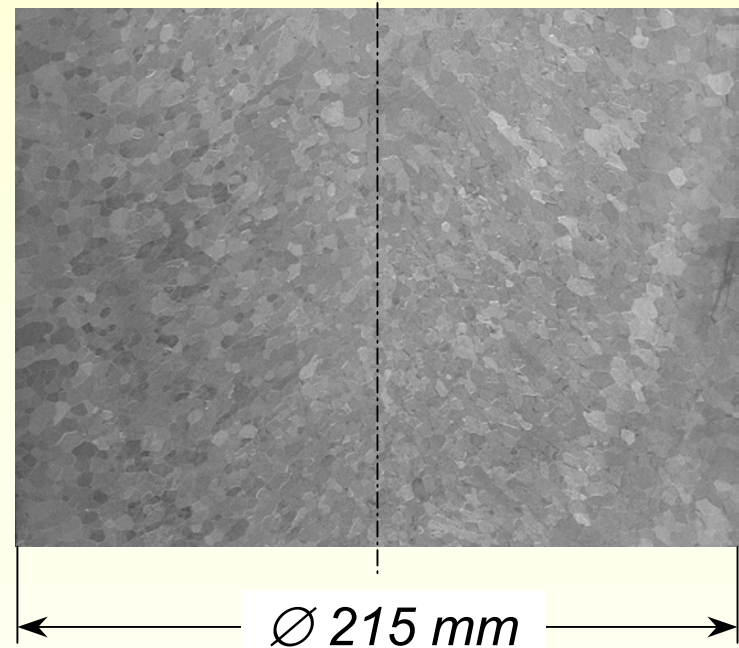



*Ingots of alloy **Ti-10-2-3** with a diameter of 220 mm by MEM technology*



*Ingot **Ti – 35%Al** by MEM technology*

Table 1. Chemical composition of alloy Ti-10-2-3 by MEM technology

	Chemical composition, wt.%						
	V	Fe	Al	Si	O	H	N
Point 1	9.8	1.79	3.73	0.03	0.066	0.0037	0.016
Point 2	9.8	1.80	3.59	0.03	0.078	0.0047	0.015
Point 3	10.1	1.82	3.64	0.11	0.072	0.0045	0.013
Average value	9.9	1.80	3.65	0.057	0.072	0.0043	0.0147

Table 2. Distribution of alloying elements in ingot of VT22 alloy

Sampling		Content, %				
		Al	Mo	V	Fe	Cr
Head part	Center	5,20	4,86	4,90	1,0	1,1
	1/2R	5,17	4,92	4,82	1,0	1,1
	Edge	5,10	4,75	5,02	1,06	1,05
Middle	Center	5,12	4,88	4,94	1,0	1,1
	1/2R	5,20	4,80	4,90	1,0	1,0
	Edge	5,30	4,82	4,85	1,0	1,05
Bottom part	Center	5,18	4,86	4,96	0,93	1,08
	1/2R	5,10	4,90	4,96	1,0	1,1
	Edge	5,16	4,78	4,87	1,0	1,08

Table 3. Mechanical properties of alloys with disperse intermetallic strengthening.

Alloy	Ultimate Tensile Strength, MPa	Elongation, %	Reduction of Area, %	Impact strength (U-notch), J/cm²
VT22 + 0,2%C	1280-1360	14,0	35	22-20
VT22 + 0,3%C	1325-1370	12,0	34	20
VT22 + 0,2%B	1330-1340	8,0	27	24-22
VT22 + 0,25%C + 0,2%B (VT22PT)	1320-1370	7,0	20	18-15

** After deformation and heat treatment: 820^oC - 1 hour, air cool, age at 540^oC - 4 hours.*

Table 4. Mechanical properties of alloys with matrix of the base solid solution of niobium and molybdenum.

Chemical composition, wt.%	Mechanical properties			
	Ultimate Tensile Str., MPa	Elongation, %	Reduction of Area, %	Long term strength (100 Hours, 700°C), MPa
Ti + 4,5 Al + 25 Nb + 5,0 Mo + 0,15 B + 0,15 C + 0,15 Si	1230	4,5	6,5	320
Ti + 4,5 Al + 25 Nb + 5,0 Mo + 0,1 B + 0,1 C + 0,1 Si + 4,0 Fe	1380	3.5	5.5	350

** After deformation and heat treatment:*

*900°C - 1 hour, air cool,
age at 620°C - 6 hours.*

*** After deformation and heat treatment:*

*820°C - 1 hour, air cool,
750°C - 1 hour, air cool
age at 620°C - 12 hours.*

Conclusions

1. Development of new multicomponent titanium alloys is necessary to realize in combination with the development of special methods of melting, which guarantee the reproducibility of properties of these alloys.
 2. The technology of MEM of titanium alloys has been developed which can produce ingots with a high chemical and structural homogeneity and precise preset chemical composition.
 3. In MEM the directed EVF of melt are generated in longitudinal magnetic field which equalize the temperature field of the metal pool and intensify the heat- and mass exchange in the metallurgical pool.
 4. MEM in longitudinal magnetic field makes it possible to decrease in depth (volume) the metal pool and to equalize the front of metal crystallization.
 5. In MEM in transverse magnetic field a vibration of melt, refining the crystalline structure of the ingot, is created.
 6. Titanium alloys of MEM technology with intermetallic strengthening possess high strength and heat resistance and preserve the necessary ductility.
-
-