

Formation of submicrocrystalline structure in large size billets and sheets out of titanium alloys

G.A. Salishchev,

Institute for Metals Superplasticity Problems, Ufa, Russia

Report Documentation Page

*Form Approved
OMB No. 0704-0188*

Public reporting burden for the collection of information is estimated to average 1 hour per response, including the time for reviewing instructions, searching existing data sources, gathering and maintaining the data needed, and completing and reviewing the collection of information. Send comments regarding this burden estimate or any other aspect of this collection of information, including suggestions for reducing this burden, to Washington Headquarters Services, Directorate for Information Operations and Reports, 1215 Jefferson Davis Highway, Suite 1204, Arlington VA 22202-4302. Respondents should be aware that notwithstanding any other provision of law, no person shall be subject to a penalty for failing to comply with a collection of information if it does not display a currently valid OMB control number.

1. REPORT DATE 18 MAR 2004	2. REPORT TYPE N/A	3. DATES COVERED -	
4. TITLE AND SUBTITLE Formation of submicrocrystalline structure in large size billets and sheets out of titanium alloys		5a. CONTRACT NUMBER	
		5b. GRANT NUMBER	
		5c. PROGRAM ELEMENT NUMBER	
6. AUTHOR(S)		5d. PROJECT NUMBER	
		5e. TASK NUMBER	
		5f. WORK UNIT NUMBER	
7. PERFORMING ORGANIZATION NAME(S) AND ADDRESS(ES) Institute for Metals Superplasticity Problems, Ufa, Russia		8. PERFORMING ORGANIZATION REPORT NUMBER	
9. SPONSORING/MONITORING AGENCY NAME(S) AND ADDRESS(ES)		10. SPONSOR/MONITOR'S ACRONYM(S)	
		11. SPONSOR/MONITOR'S REPORT NUMBER(S)	
12. DISTRIBUTION/AVAILABILITY STATEMENT Approved for public release, distribution unlimited			
13. SUPPLEMENTARY NOTES See also ADM001672., The original document contains color images.			
14. ABSTRACT			
15. SUBJECT TERMS			
16. SECURITY CLASSIFICATION OF:			17. LIMITATION OF ABSTRACT
a. REPORT NATO/unclassified	b. ABSTRACT unclassified	c. THIS PAGE unclassified	UU
			18. NUMBER OF PAGES 49
			19a. NAME OF RESPONSIBLE PERSON

Acknowledgements

The author would like to thank his colleagues R.M. Galejev, S.V. Zherebtsov, S.Yu. Mironov, O.R. Valiachmetov, S.P. Malysheva together with which were obtained results presented and wish to acknowledge Dr. I. Semiatin for fruitful discussion in part of these results.

Introduction

1. Materials with a submicrocrystalline structure have an average grain size less than 1 μm .
2. They show enhanced mechanical properties such as increased strength, fatigue resistance, improved ductility and superplasticity at lower temperatures.
3. The decrease in temperature of secondary processing leads to a decrease in tool costs and material savings due to reduced contamination.

Superplastic characteristics of pure titanium and two-phase titanium alloys

Material	d, μm	t, $^{\circ}\text{C}$	ε, s^{-1}	δ, %	m	σ, MPa
Titanium of VT1-00 grade	0,2	550	5×10^{-4}	190	0.32	90
	10	600	3.3×10^{-4}	140	0.26	120
Ti-6.7Al-4.7Mo	0.06	575	2×10^{-4}	1200	0.45	165
	5	800	5×10^{-4}	600	0.4	80
Ti-6Al-4V	0.3	600	5×10^{-4}	500	0.34	200
	5	800	5×10^{-4}	600	0.4	30
Ti-11Mo-5.5Sn-4Zr	0.3	550	5×10^{-4}	390	0.46	130
	0.5	625	7×10^{-4}	580	0.47	100
	5	725	3.3×10^{-4}	180	0.3	70

Methods of Severe Plastic Deformation

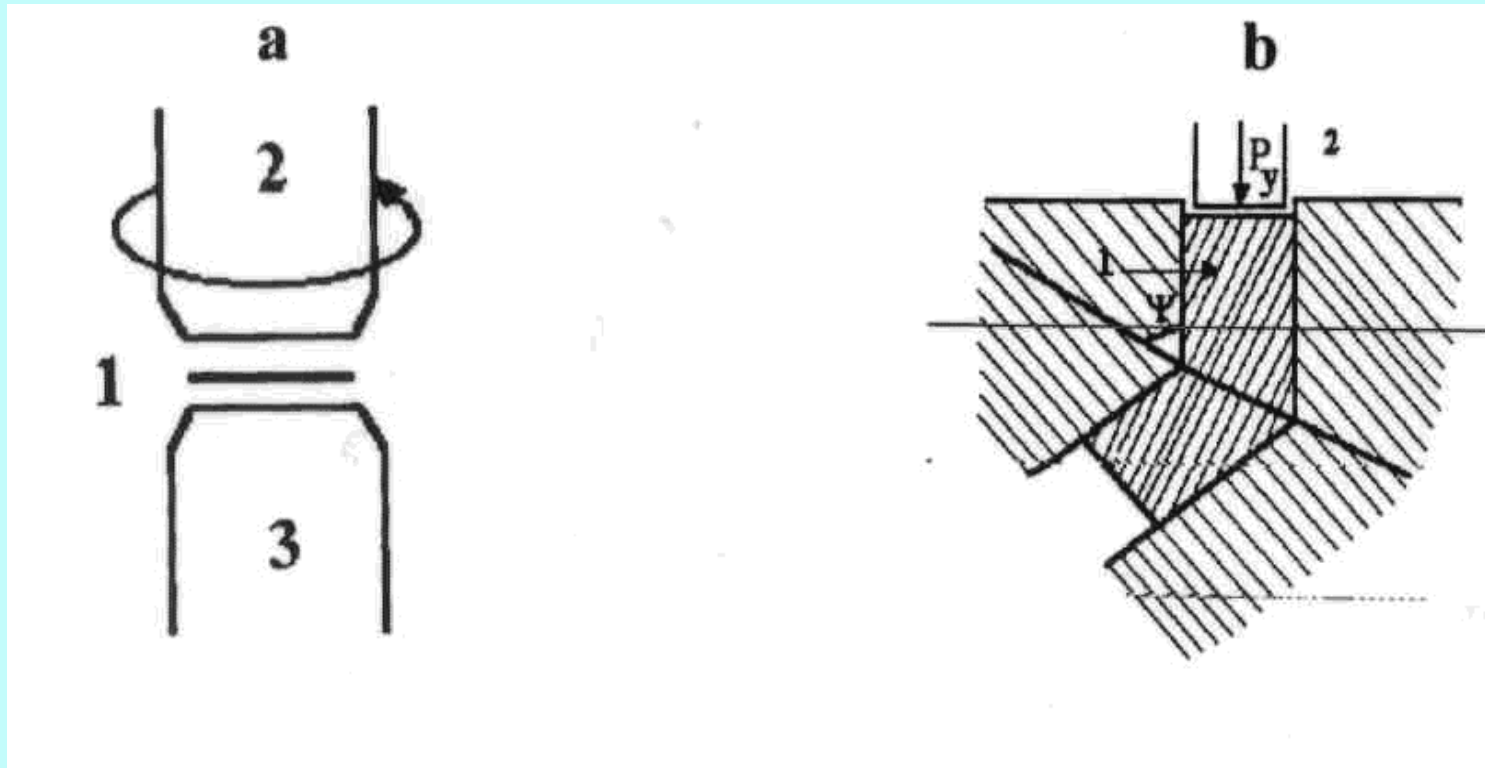

torsion under
pressure

equal channel
angular extrusion

Geometry at Shaping Steps during “abc” Forging



Step 1: Upset

Step 2: Cant and upset



Step 3: Cant and upset

Step 4: Draw



The Features of Severe Plastic Deformation

- 1. High Stresses and Density Defects
- 2. Formation of Deformation Induced Dislocation Boundaries (V.V. Rybin, D. Kuhlmann-Wilsdorf, N. Hansen)
- 3. Macroscopic Direction of These DIBD That Leads to Formation of Banded Structure and Fragmentation
- 4. In a Material, as Titanium, Twinning Accompanies with These Processes

The Change in the strain path allows

- 1. To remain an initial shape of billets that should be almost unchanged for attaining large strains
- 2. To involve additional slip and twinning systems in plastic flow
- 3. To interact DIBD at their intersection
- 4. To scatter the microstructure formed at previous stage of deformation due to Baushinger's effect

The features of microstructure refinement in alpha/beta titanium alloys with lamellar structure

1. Transformation of lamellar microstructure into equiaxed one takes place due to development of globularization.
2. Lamellar microstructure in titanium alloys has high thermal stability due to high interface energy anisotropy
3. The process develops by means of substructure formation in the lamellas of phases, division of lamellas and transformation of lamellas parts into globular particles.
4. Keep the process its main features in the case of SMC structure formation?

Occurrence of shear localized flow at plastic deformation



Plastic deformation occurs by process developing on macroscopic, mesoscopic and microscopic scales. Macroscopic scale of deformation is shear localized flow. Mesoscopic scale is occurrence and spreading of deformation induced dislocation boundaries. Microscopic scale is slip and twinning. What is their role for refining microstructure? How are they connected with each other? What is the effect of starting microstructure (lamellar or equiaxed) on the refining microstructure process and mechanical behavior?

The objective of the present work

- to investigate the features of microstructure evolution and mechanical properties of titanium and Ti-6Al-4V alloy during “abc” deformation at SMC structure formation conditions**
- to develop the methods for production large-scale billets and sheets with SMC structure**

OUTLINE

- 1. Microstructure evolution and mechanical behavior of Ti and Ti-6Al-4V alloy during “abc” deformation will be studied.**
- 2. The effect of strain path at the SMC structure temperature condition on evolution microstructure and mechanical behavior of both Ti and Ti-6Al-4V alloy will be studied.**
- 3. The methods to produce large-scale billets and sheets will be developed.**

EXPERIMENTAL

- The commercial pure titanium with a mean grain size of 35 μm and the alpha/beta titanium alloy Ti-6Al-4V with a mean β -grain size of 250 μm were used.
- Using compression test a flow stress – engineering strain curves for all steps of “abc” deformation were plotted.

It were studied deformation relief, fine structure by X-ray diffraction, SEM, TEM and by EBSD analysis.

Scheme of 'abc' deformation

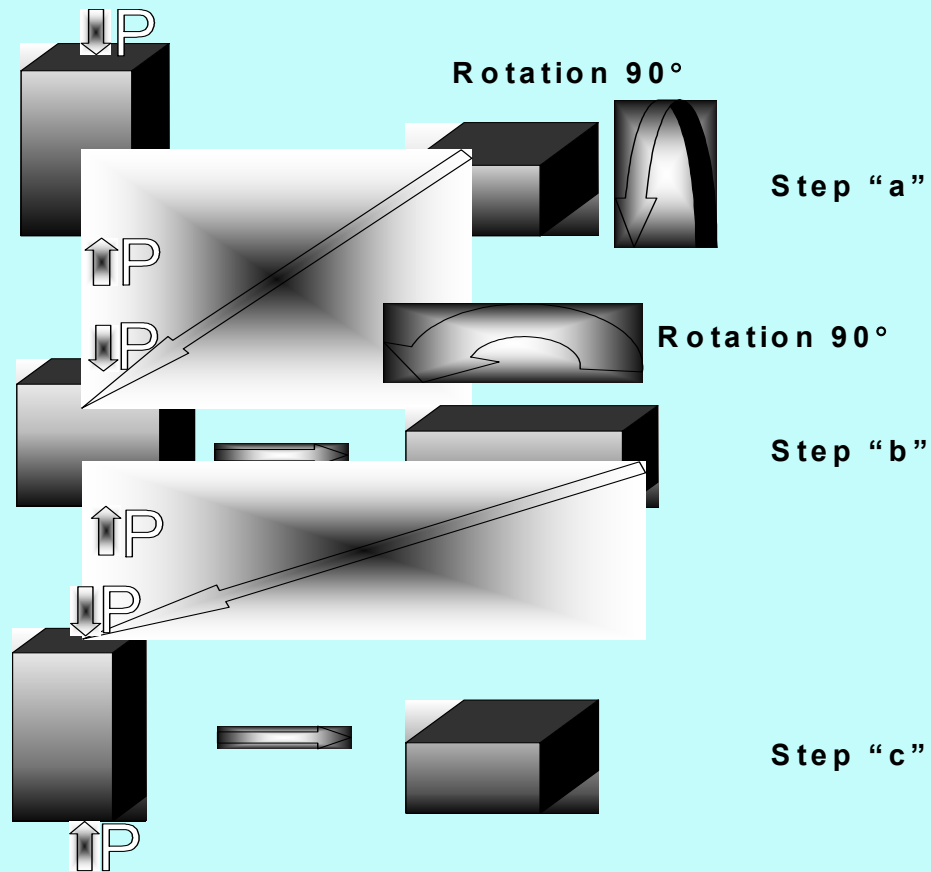

Conditions of 'abc' Testing

- A total of 12 and 7 increments in deformation of titanium and Ti-64 alloy samples respectively were imposed.
- Temperatures $-400\text{ }^{\circ}\text{C}$ for Ti, $550\text{ }^{\circ}\text{C}$ for Ti-64 alloy
- strain rate - 10^{-3} s^{-1}
- strain per deformation step ~ 0.4

Cumulative S- Σe curve for 'abc' deformation of Ti at 400°C and $10^{-3}s^{-1}$

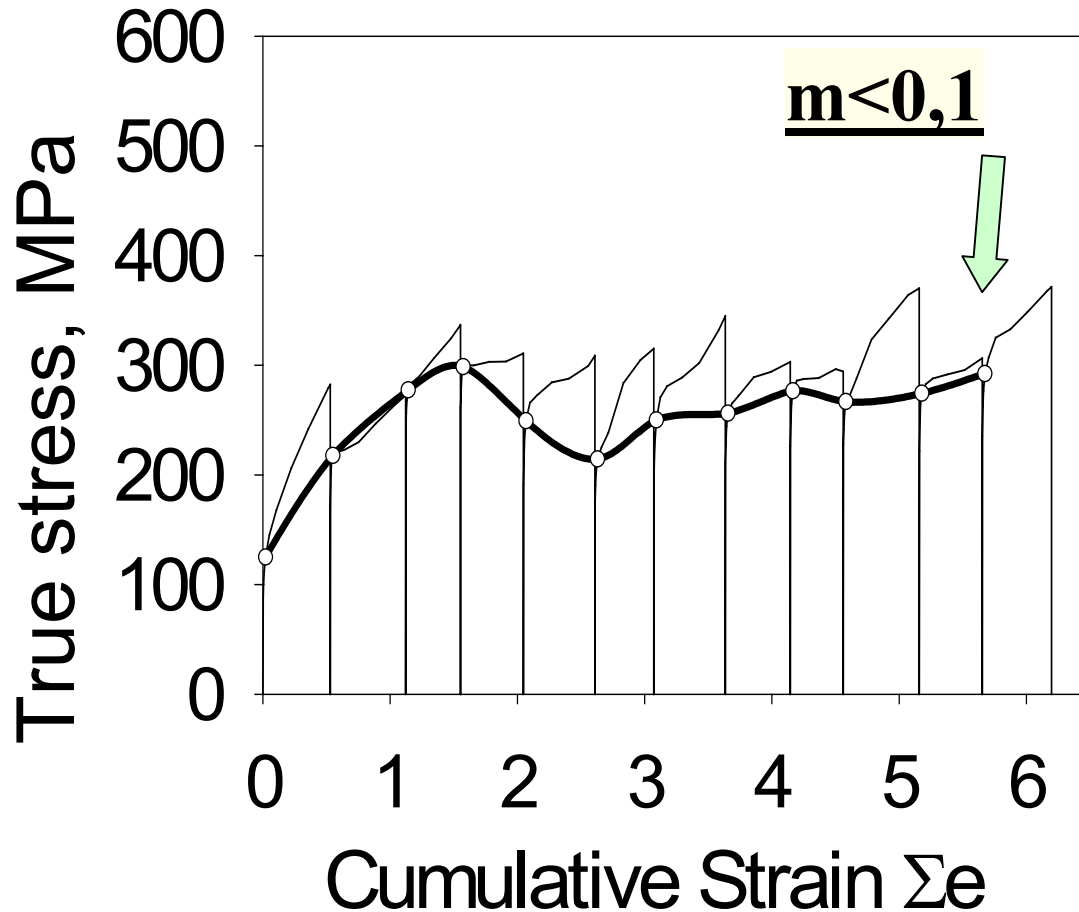

The cumulative Σe -S curve has tendency to hardening during increments of cycles. The considerable drop in the yield stress at each succeeding step as compared to flow stress at the end of the previous one and the strain hardening observed. There is no sign of steady stage flow on the accumulated curve.

Macroshear Bands in Titanium

Compression at 10^{-3}c^{-1} to 40% Height Reduction at 400 °C

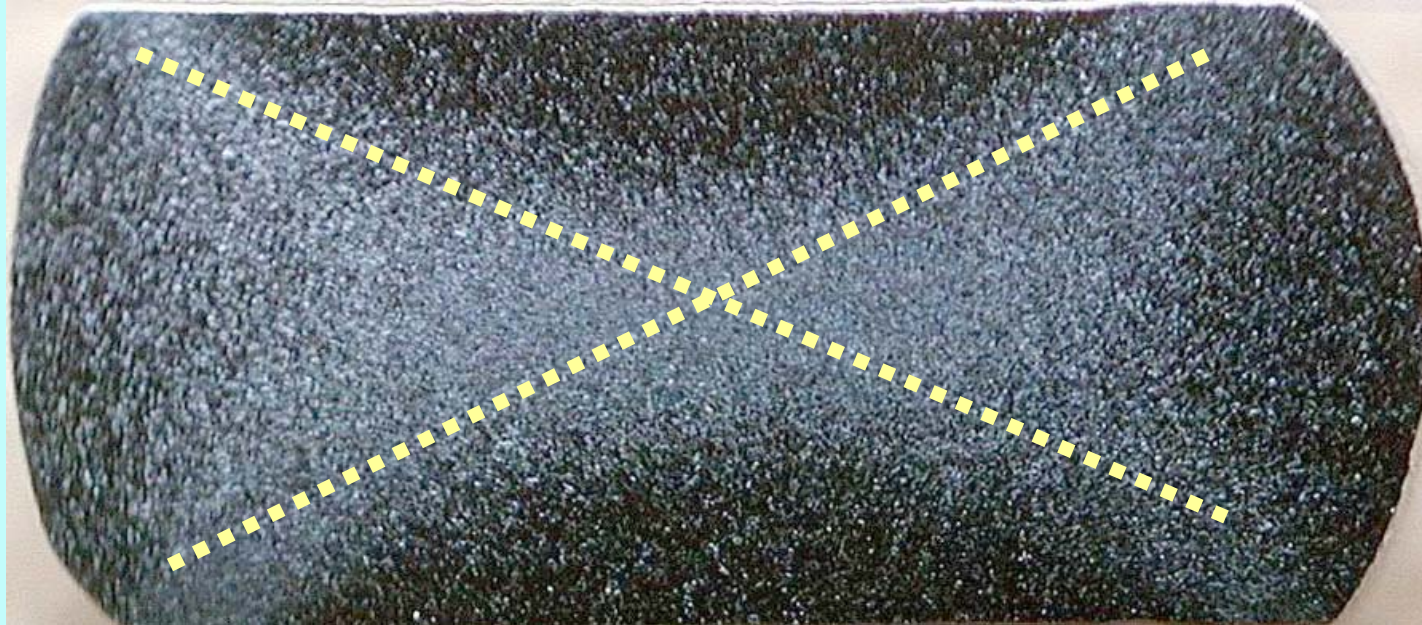

Due to friction and geometrical constraints **shear localization flow** occur in the sample. On each step of “abc” deformation microstructure evolution takes place in such **macrobands** mainly. Change of compression direction leads to structure reorganization in accordance with the new deformation conditions.

(002) pole figures of titanium in initial condition (a) and after different steps of deformation:

b – 3, c – 5 and d – 12 steps.

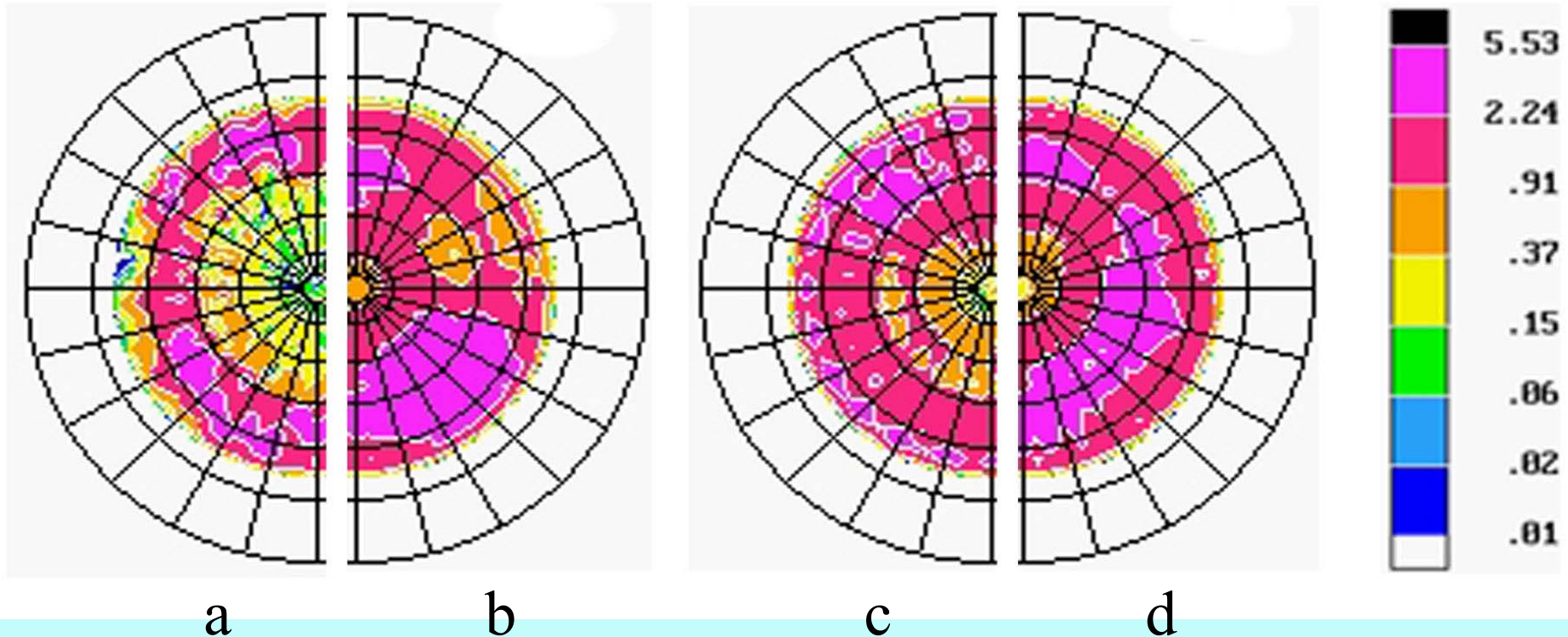

After each step of deformation qualitatively similar axial textures form. Changing the axis of loading leads to reorganization of microstructure to adjust to new conditions of deformation.

Microstructure evolution of Ti during “abc” deformation at 400°C and 10^{-3} s^{-1}

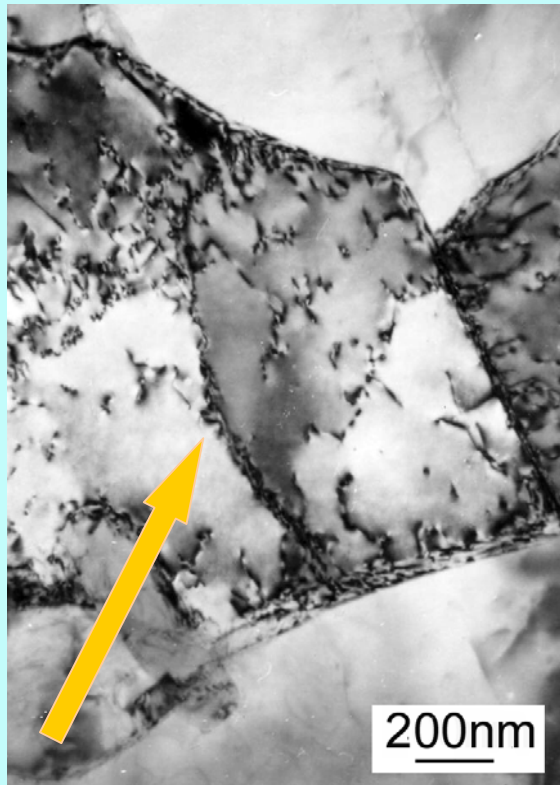

$\Sigma e = 0,22$

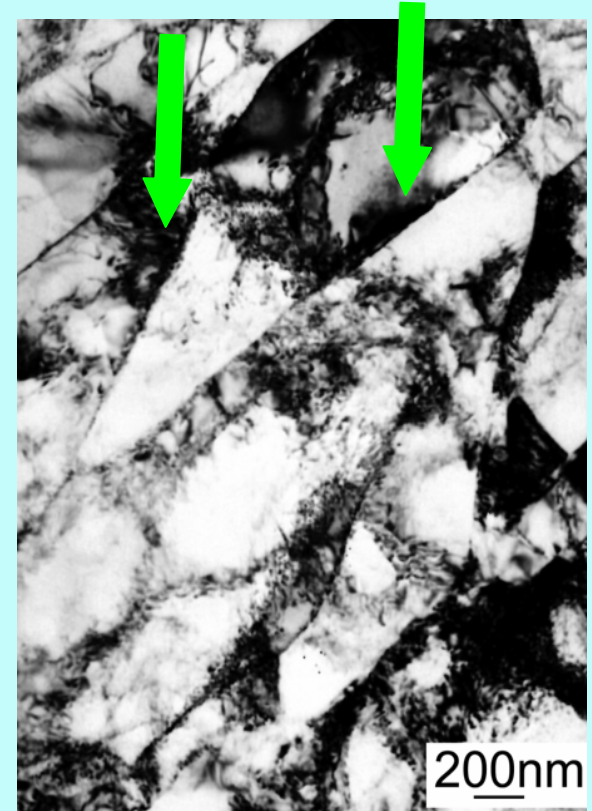

$\Sigma e = 1,5$

- At the initial step deformation induced dislocation boundaries occur.
- Then extended (tens of micrometers) dislocation boundaries transforming initial structure into banded one are formed.

Deformation relief pattern after strain at 400°C

$\Sigma e=2,5$

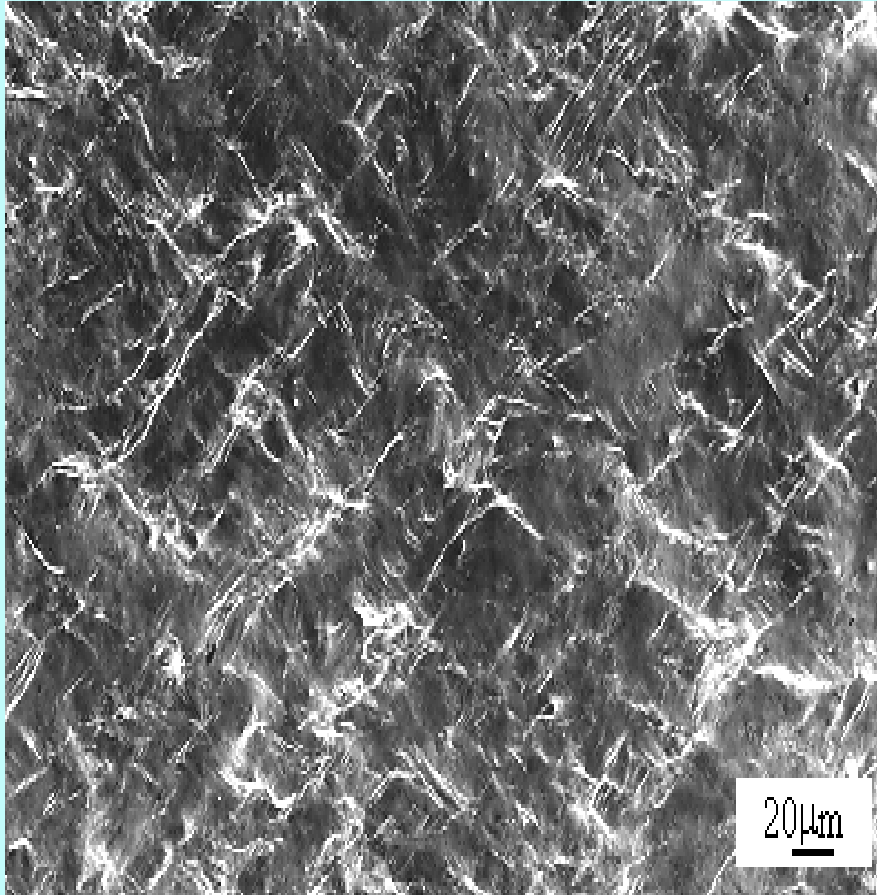

$\Sigma e=6$

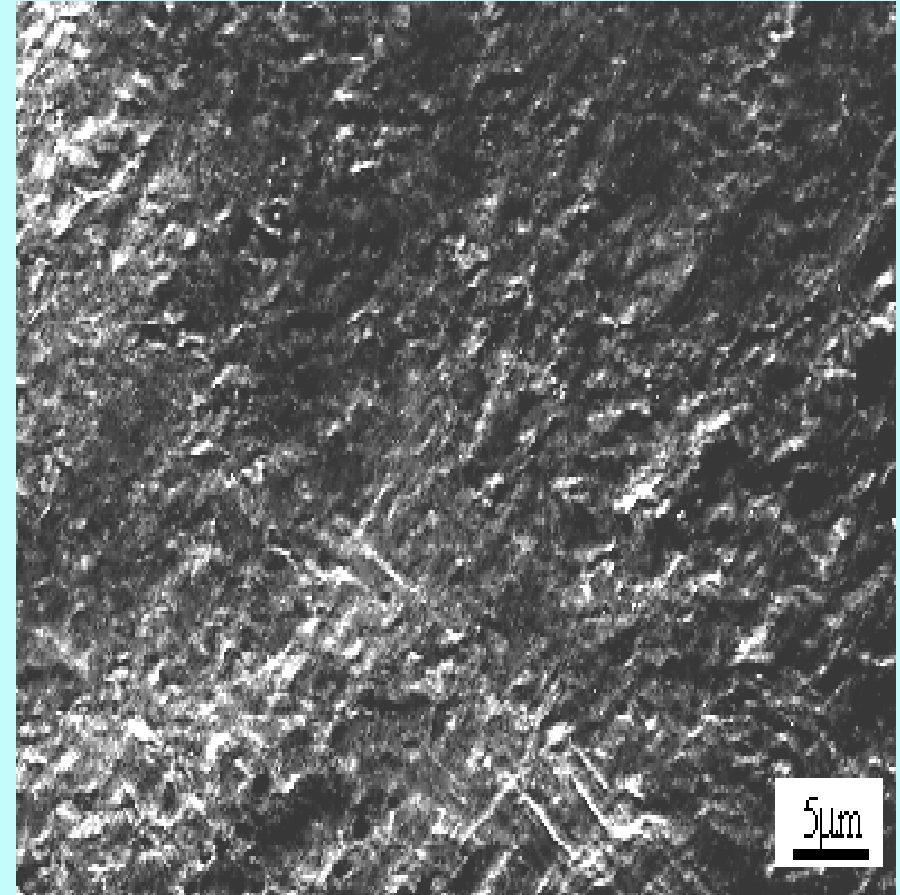

Length of deformation induced dislocation boundaries reaches up to one to two hundred micrometers on deformation relief pattern. To final step they become shorter.

Microstructure of Ti after “abc” deformation at 400°C and 10^{-3} s^{-1}



$\Sigma e=6$

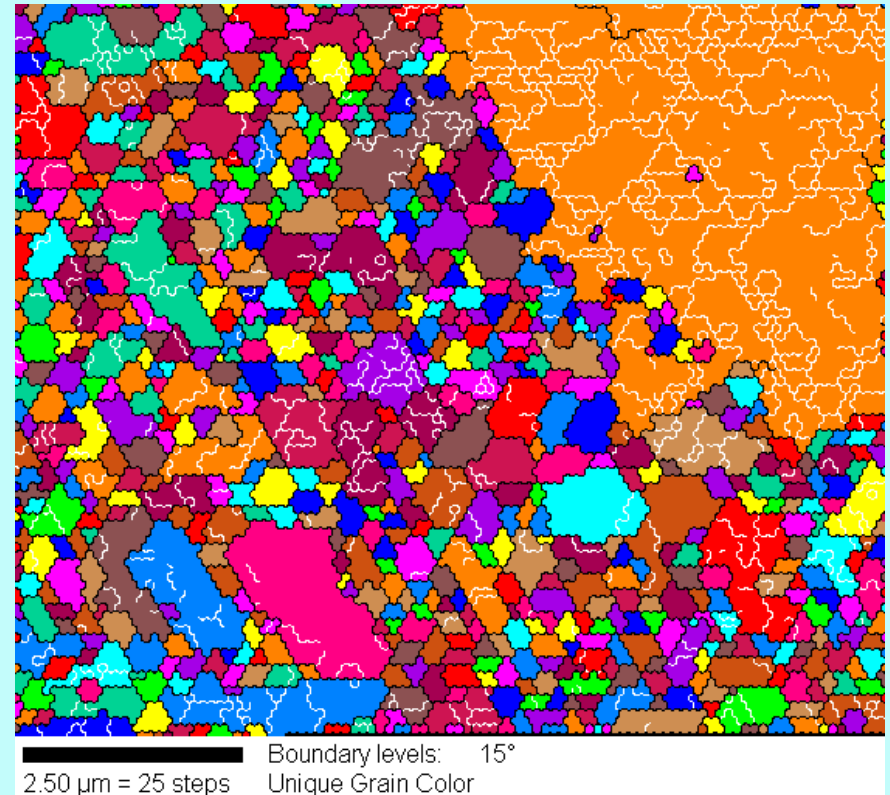

SMC grains are formed as a result of occurrence and crossing of deformation induced high angle boundaries. The final microstructure with an average grain size of 0.4 micrometers is heterogeneous, since there are subgrains and coarse grains in the microstructure.

Bar chart of grain size distribution and their specific fraction in SMC Titanium

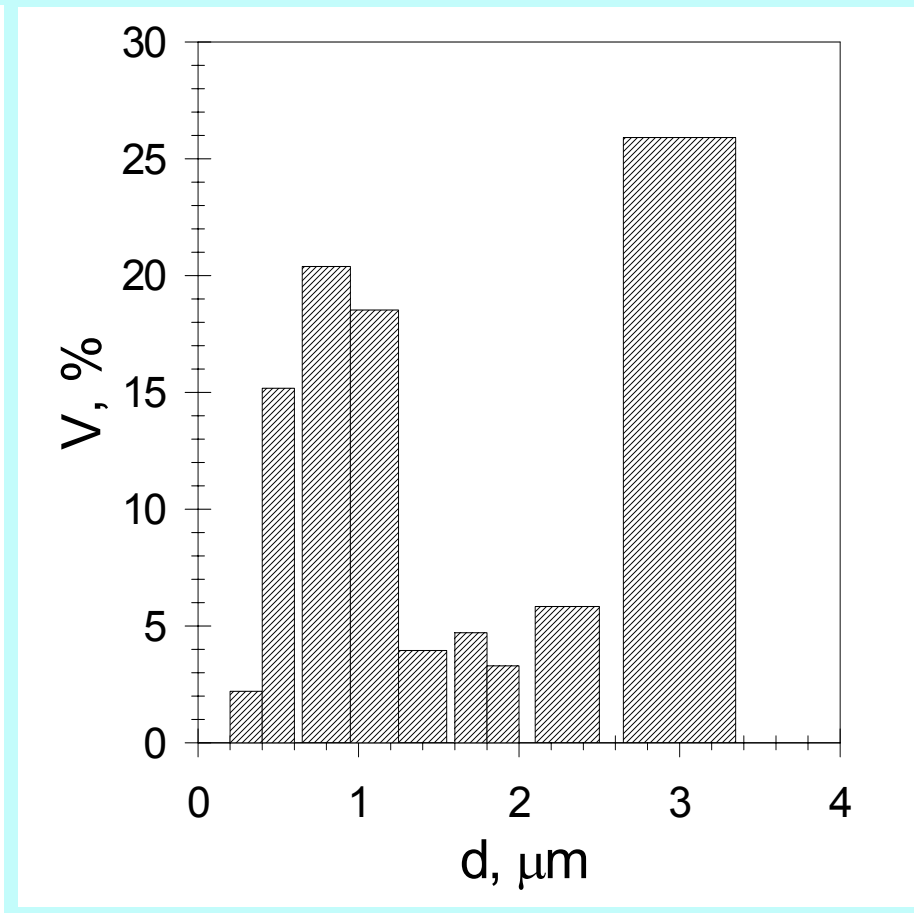
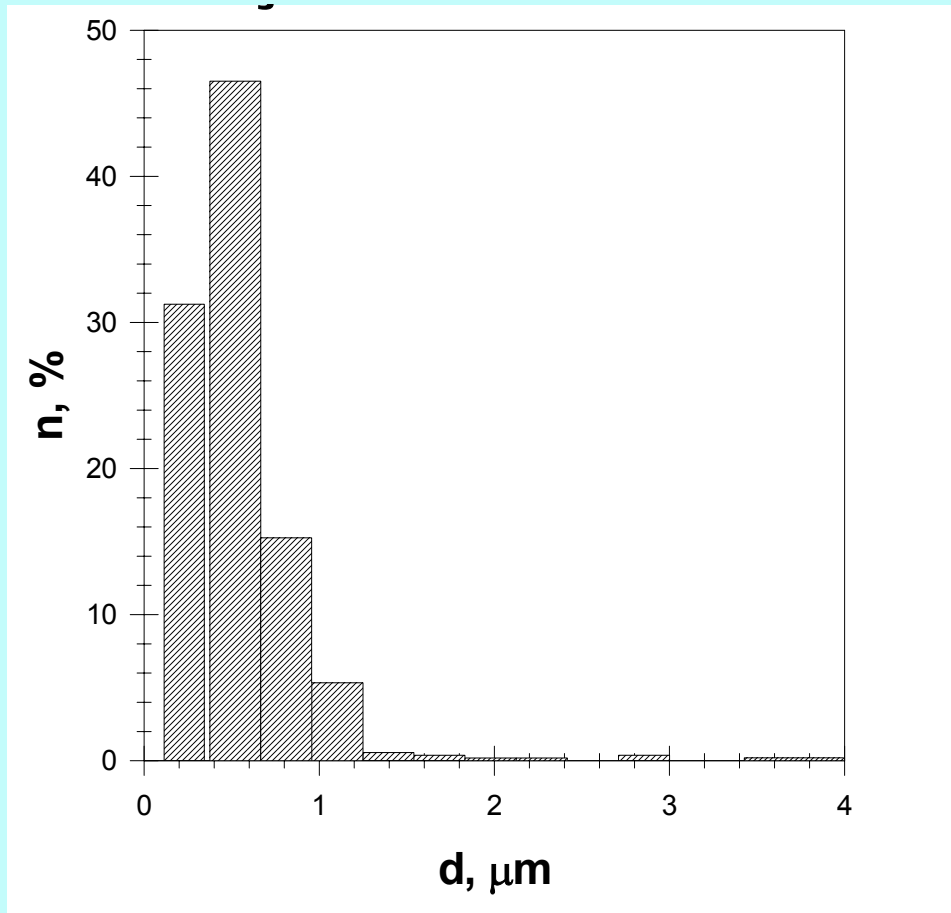

Changes of crystallographic parameters of twined boundaries

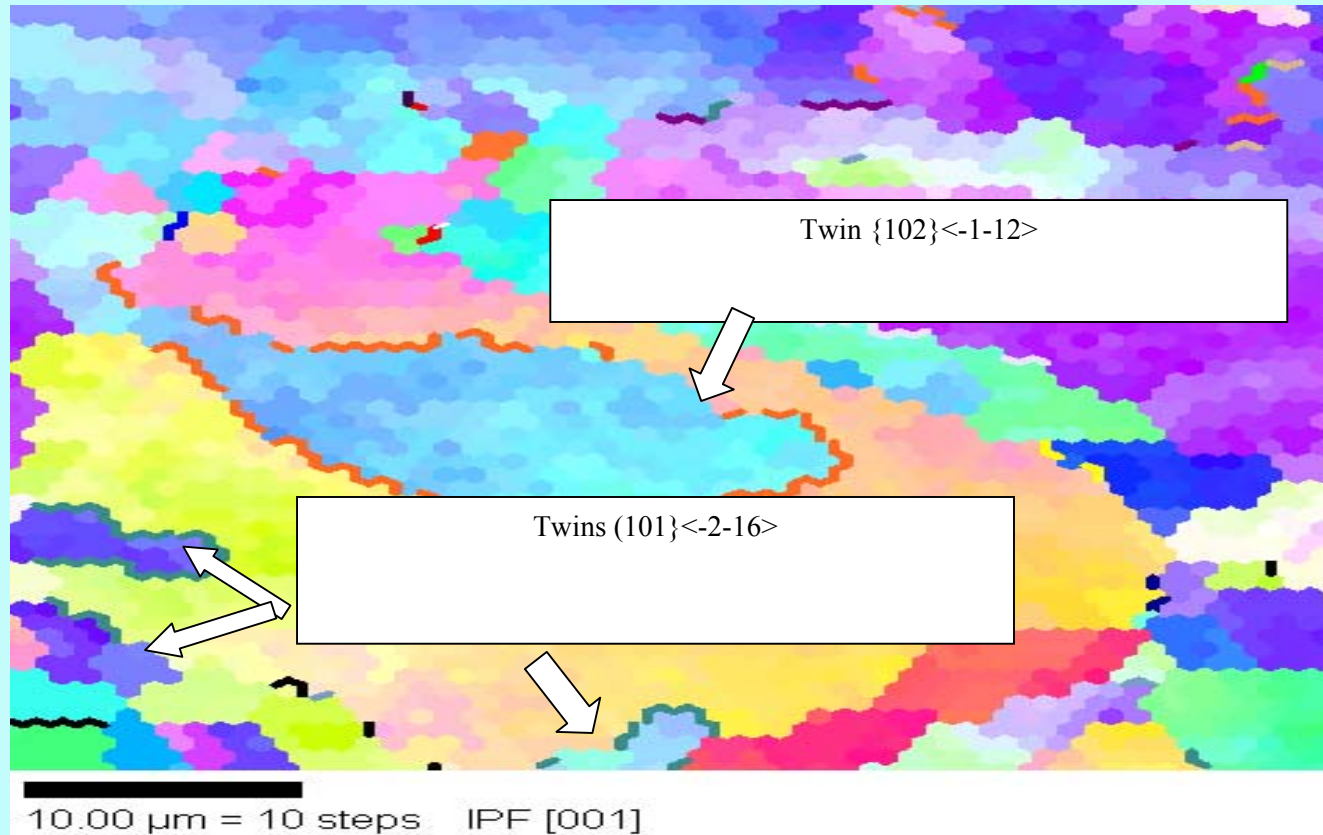

- Misorientations axes and angles of boundaries, which surround twins, do not correspond precisely to twin-matrix conjugation.
- Transformation twined boundaries in high angle boundaries because of their interaction with dislocations

Effect of cumulative deformation on the distribution of boundaries misorientation spectrum in Ti

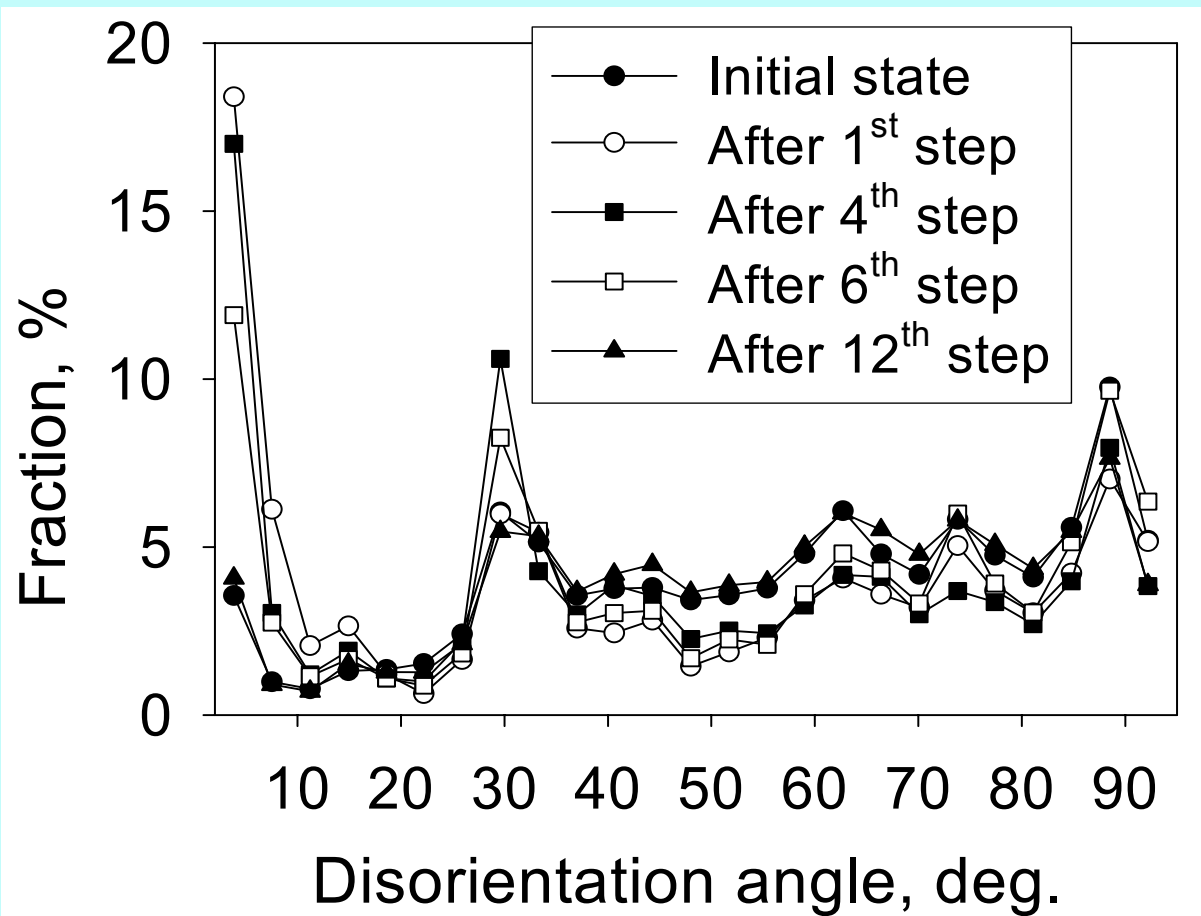

Changes of crystallographic parameters of random high angle boundaries

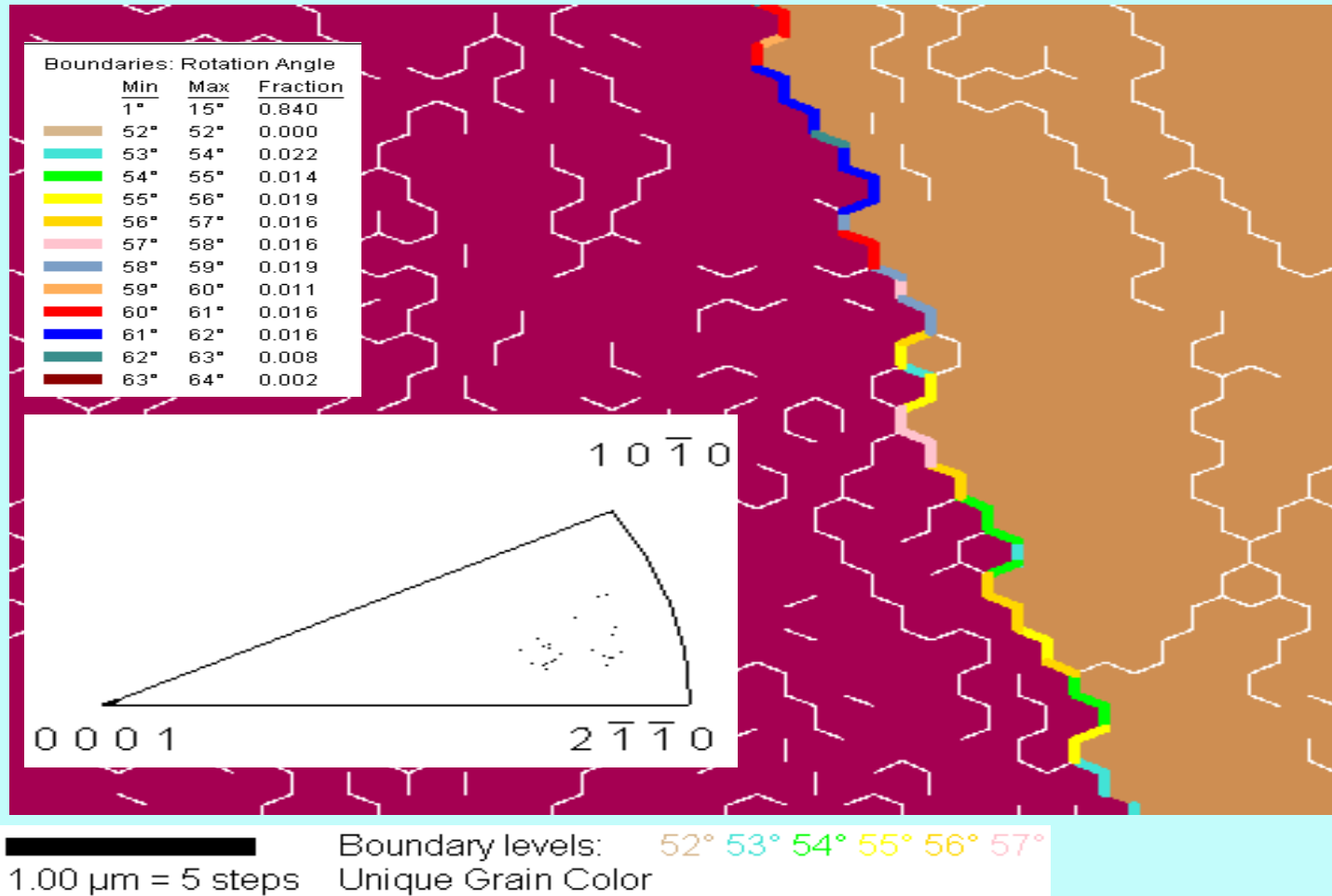

- The angles and the axis of misorientation are not discrete and constant along the boundary but they vary within rather wide range.

Original grain boundary

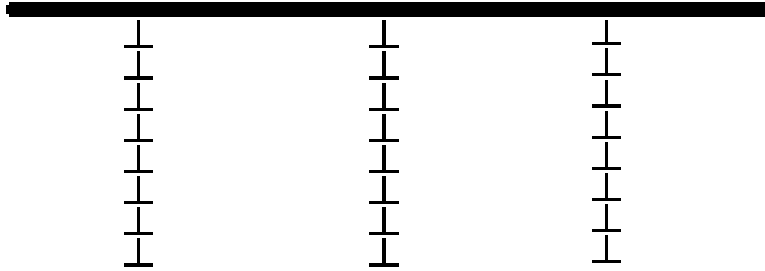

Deformation induced dislocation boundaries

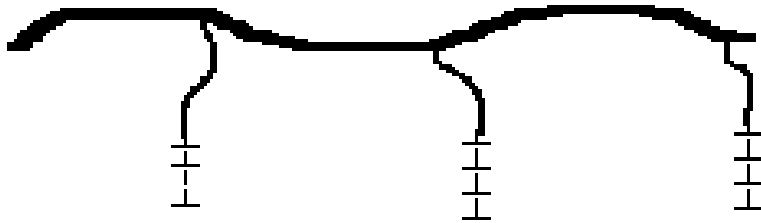

Deformation induced high-angle boundaries

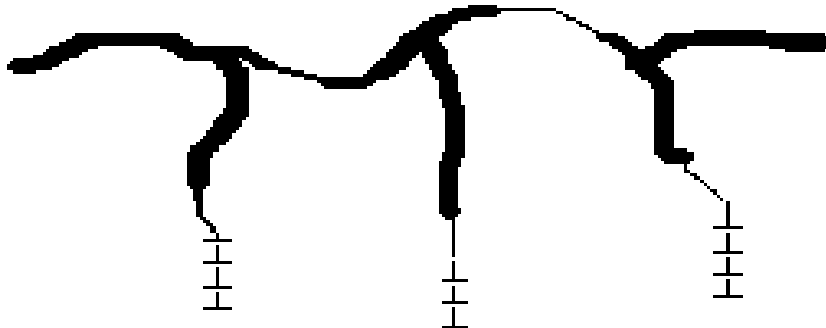

Scheme shows that the occurrence and the growth of deformation induced dislocation boundaries leads to the inconstancy of crystallographic parameters along of the boundary plane

conclusion

So, at macroscopic scale deformation developed by formation and spreading of MSB. At the change of the loading axis occurrence new and new MSB took place. It promoted uniformity of macroscopic scale of deformation. Inside MSB the crystals rotated to stable orientations at given loading axis. As a result deformation developed at the mesoscopic scale - new DIB formation and microstructure refinement appeared. DIB formation was result self-organization of dislocation and twinning. Spreading of new DIB and its intersection each other provided formation of new submicrocrystalline equiaxed grains.

Cumulative S- $\Sigma\epsilon$ curve for ‘abc’ deformation of Ti-6Al-4V alloy at 550°C and 10⁻³s⁻¹

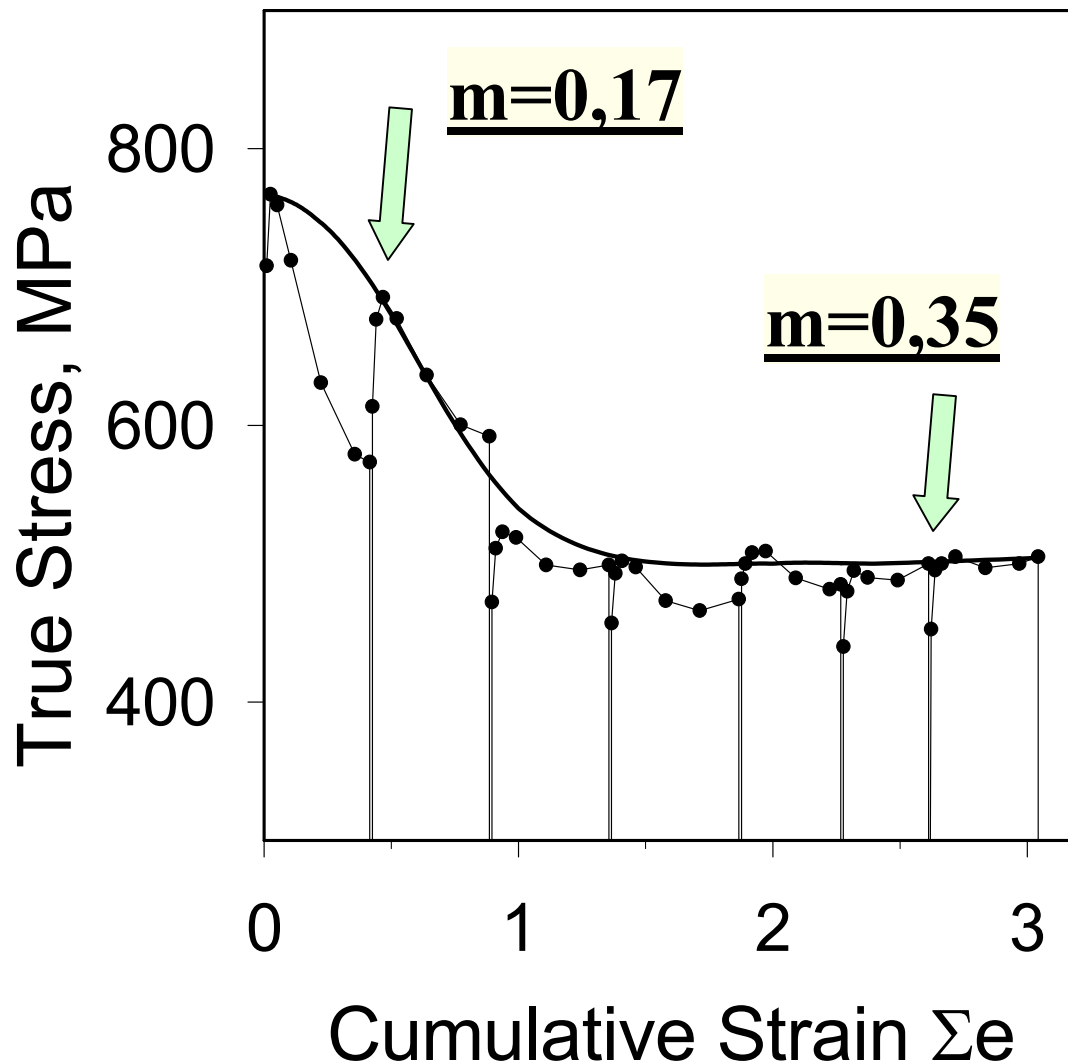

The cumulative S- $\Sigma\epsilon$ curves have a peak, softening and the steady flow stage. It is seen that with each step of loading the flow stress decreases and becomes almost constant. The presence of the steady flow stage on the true strain curves and the value of the factor m testify the transition of the alloy to the stage of superplastic flow in the process of “abc” loading.

- The stress peak is explained by strain hardening due to dislocation multiplication.
- The softening is explained by shear-localized flow due to friction and geometrical constraint. In shear macrobands softening associates with the bending of non-favorably orientated lamellae, reorientation of favorably orientated ones in regions of localized deformation, and possibly the increasing ease of slip transmission across alpha-beta interfaces.
- On steady-state stage the superplasticity is observed.

Microstructure evolution of Ti-6Al-4V during “abc” at 550°C and 10^{-3}s^{-1}

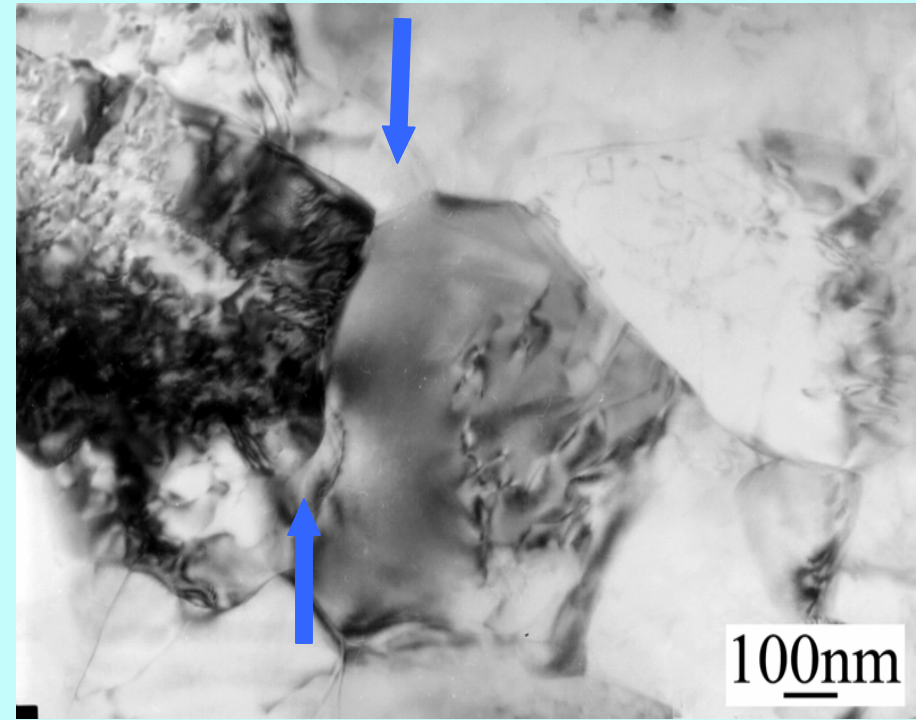
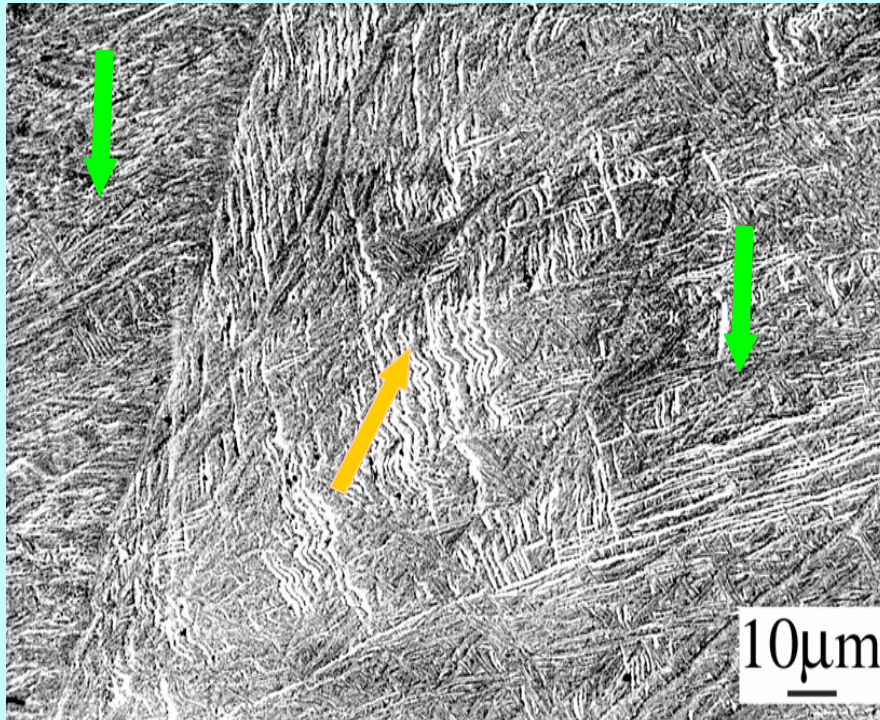

$e=50\%$

During the initial stages of deformation the bending of non-favorably orientated lamellae (■) and reorientation of favorably orientated ones (■) in regions of localized deformation occur. Grooves are formed on the surface of the α -plates (■), leading to the segmentation of the alpha plates. The fragmented β -interlayers and α -plates are thus spheroidized

Macro- and microstructure of Ti-6Al-4V alloy after “abc” deformation at at 550°C and $10^{-3}s^{-1}$



The microstructure of alloy is high homogeneous with grain size of 0,4mm. However macrostructure is no uniform. Microstructure transformation in the central area of sample takes place only.

Bar chart of grain size distribution in SMC Ti-64 alloy

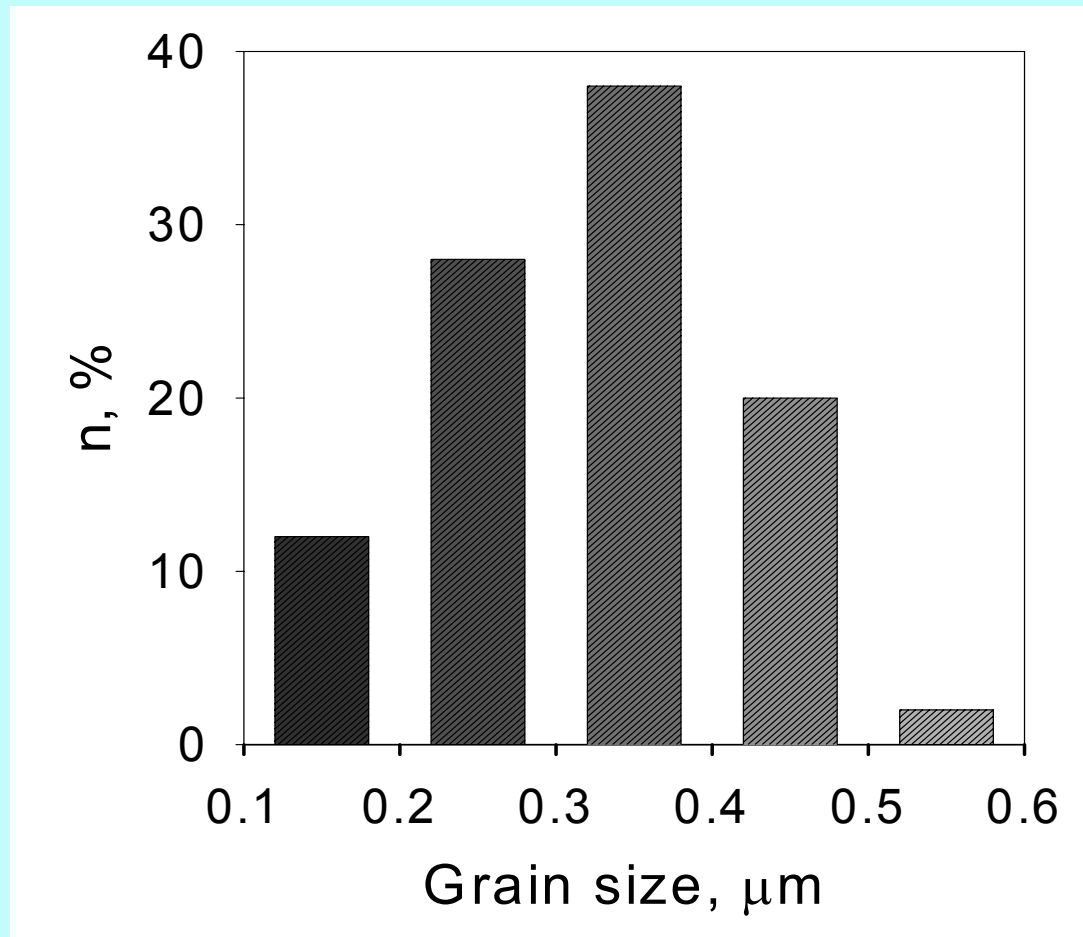

Conclusion

So, at macroscopic scale shear localization flow in the alloy develops during initial increments of deformation. Softening and globularization of structure in the macro shear band lead to realization of deformation at mesoscopic scale. In this case the mesoscopic scale deformation is determined by cooperative grain boundary sliding leading to superplastic flow. Superplastic flow results in deformation accumulation in the central area of the sample and impedes in structure transformation in periphery regions.

Computer modeling of isothermal “abc” forging

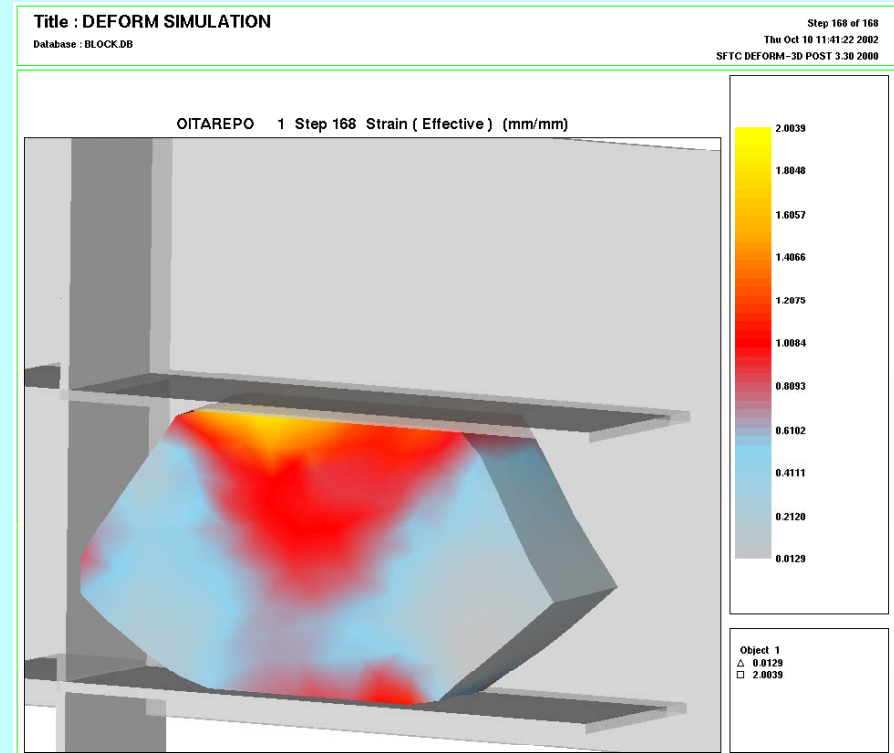
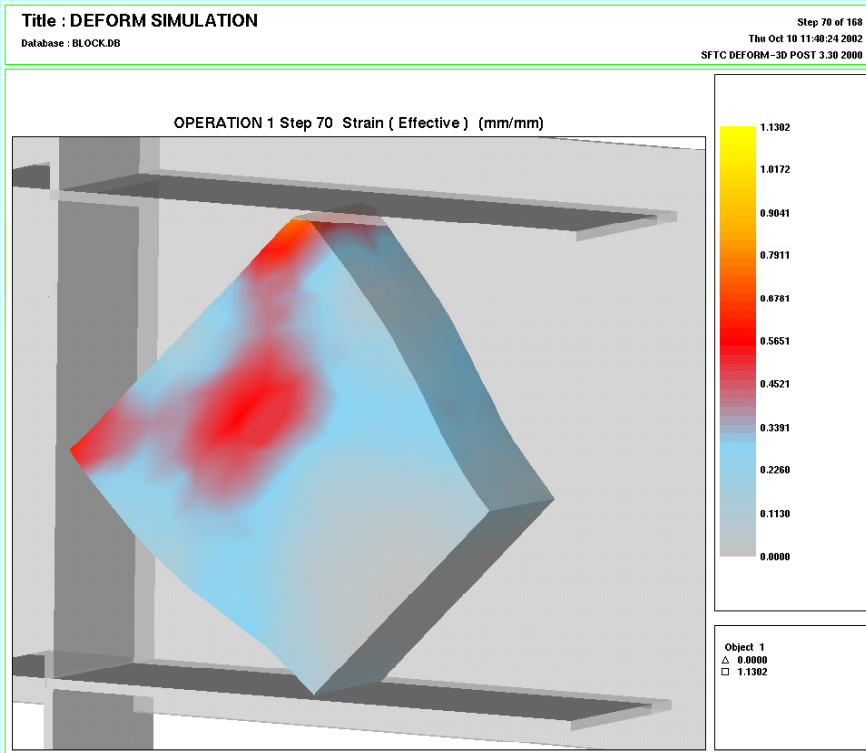

Turning of a sample to 45° during “abc” deformation leads to the more homogeneous distribution of deformation in compare with turnings to 90° only.

Device for “abc” forging

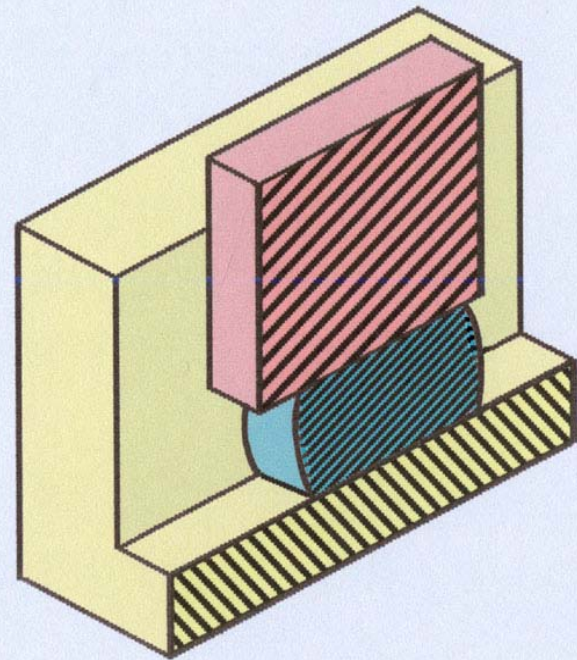
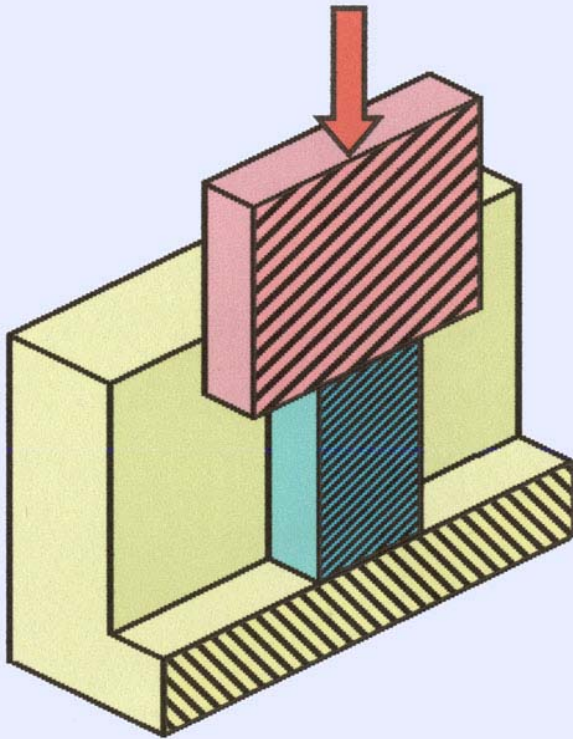

“abc” forging conditions

1. Temperature should be equal to or below 700°C (for a strain rate of $10^{-3} - 10^{-2} \text{ s}^{-1}$).
2. The preform microstructure should comprise preferably martensite or globular alpha-beta.
3. Strain at every step of deformation should be no more than 50% to prevent cracking in the billet and preserve conditions of geometrical stability of billet deformation.
4. Uniform strain in different areas of the billet can be achieved by changing strain direction during forging.

Large-size Billet with SMC Structure

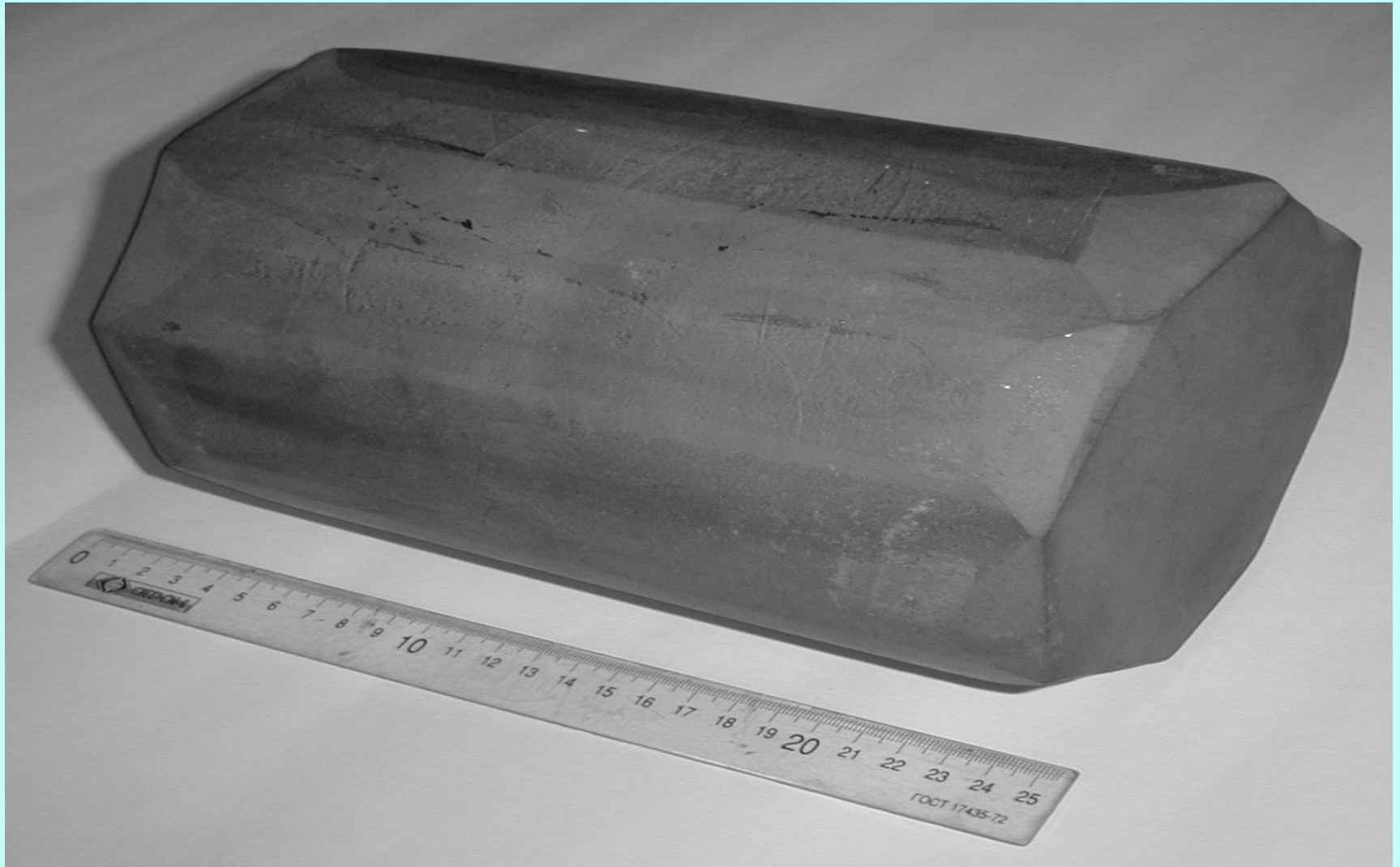

Macro-and microstructure of SMC Billet

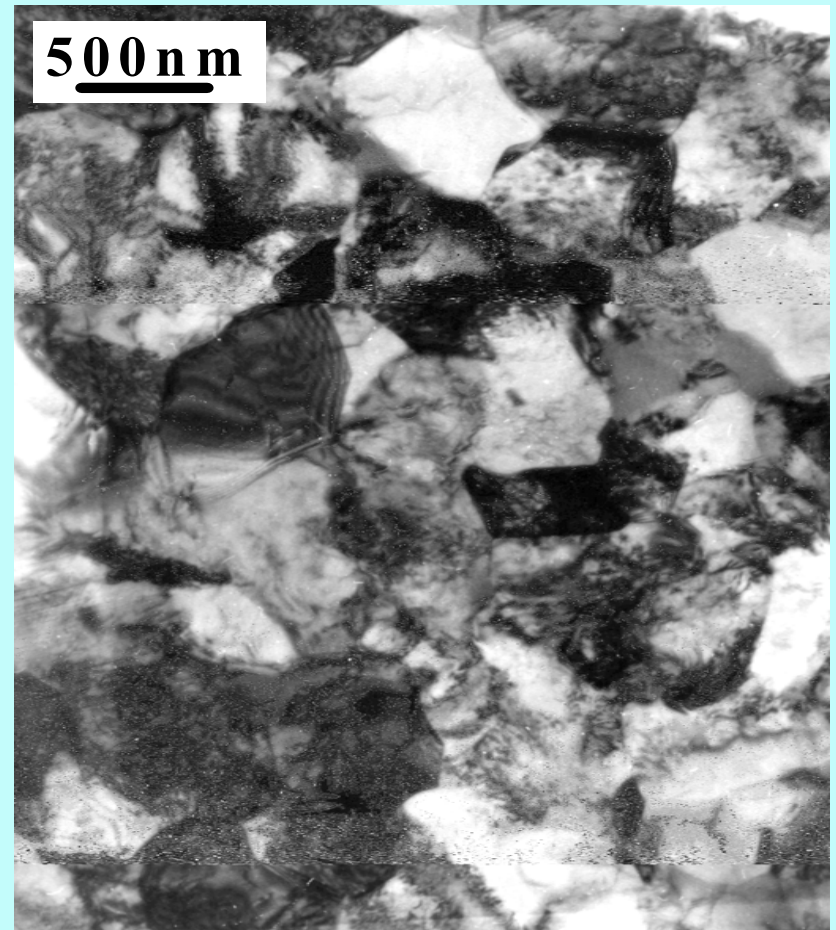
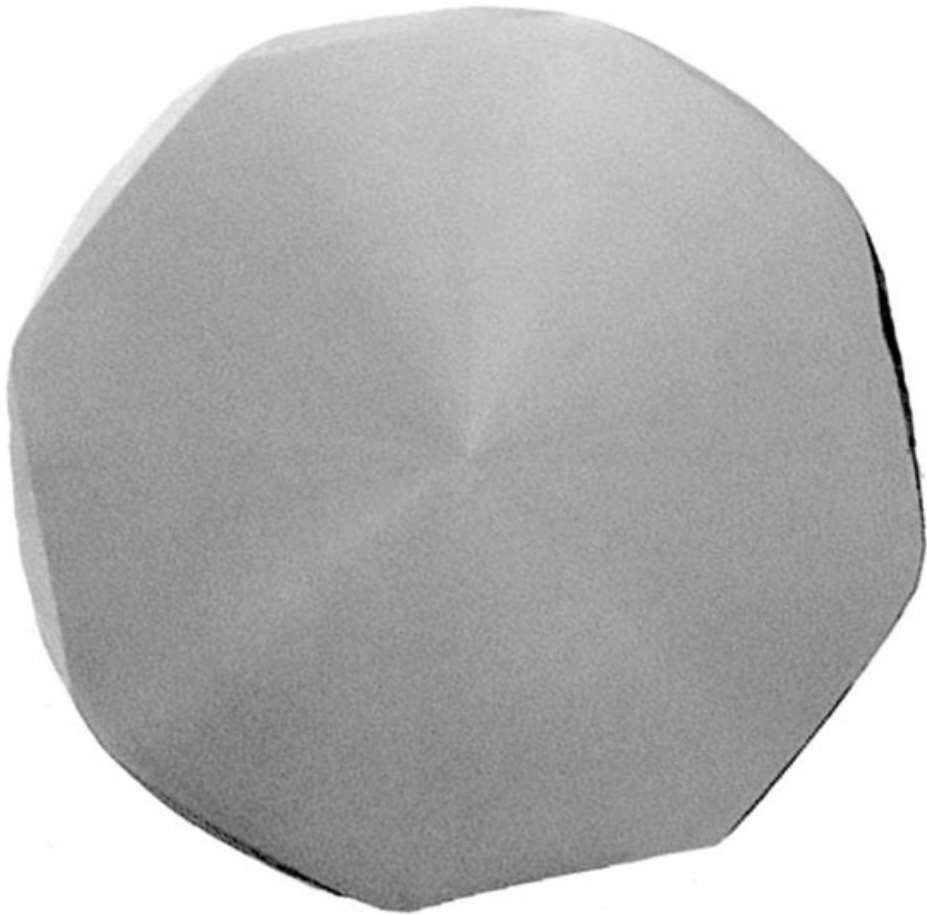

Mechanical properties of samples cut from the Ti-64 SMC billet

Direction of Sampling	YS [MPa]	UTS [MPa]	EL [%]	RA [%]
Radial	1350	1360	7	62
Tangential	1335	1355	7	61

Experimental

A abc isothermal forging in the range of $700\div 600^{\circ}\text{C}$ was used to produce preforms with a homogeneous microstructure and grain size of $0.4\ \mu\text{m}$.

The preforms were rolled by pack rolling. The laboratory scale sheets, $200\text{mm}\times 300\text{mm}\times 0.8$ and 2mm thick and commercial size sheet that is $500\text{mm}\times 1500\text{mm}\times 2\text{mm}$ thick were produced.

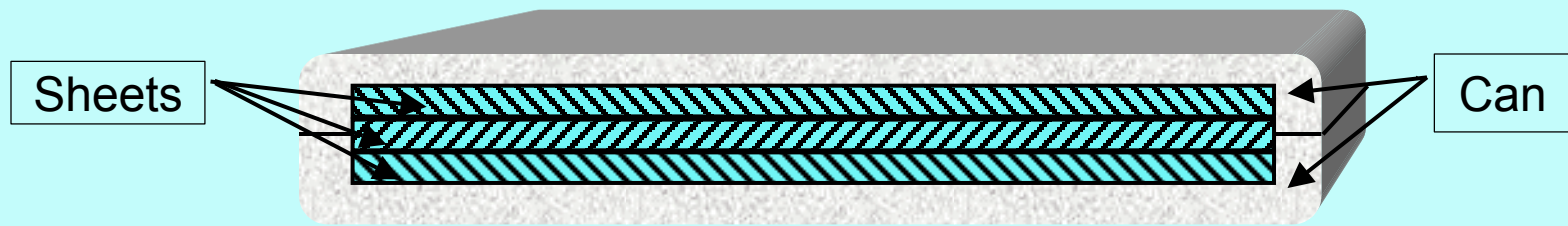

Experimental

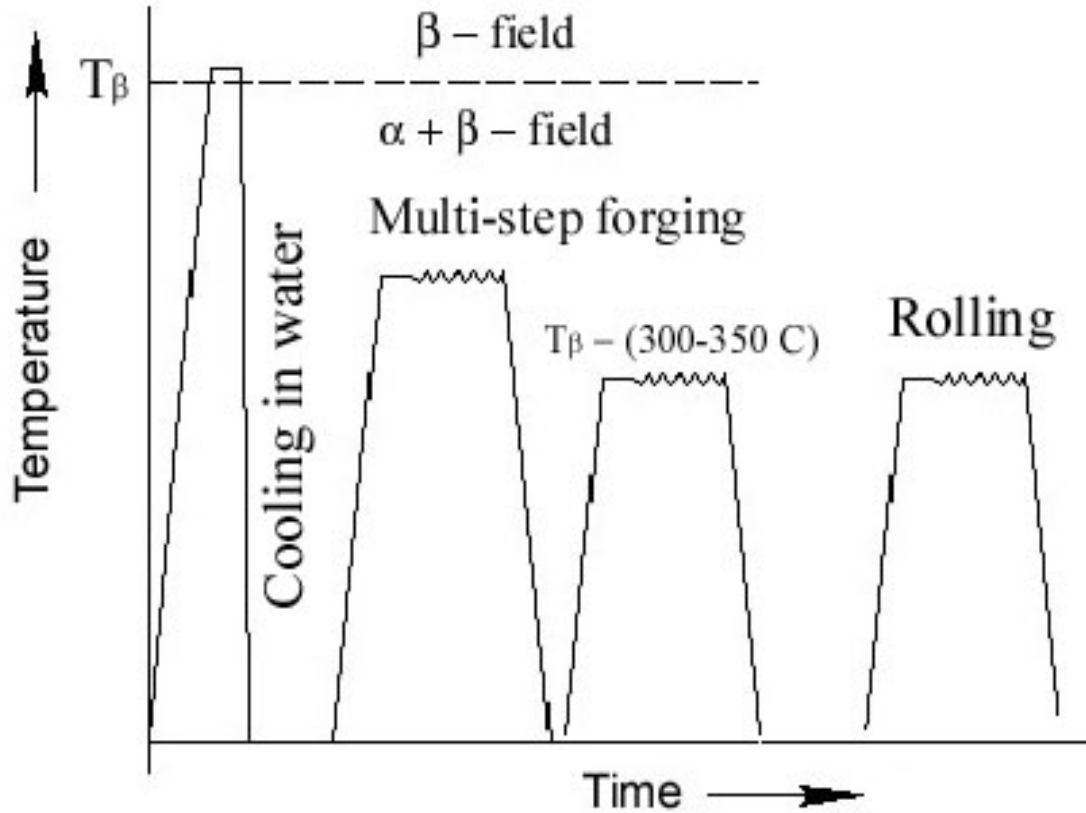

Requirements for rolling:

- 1 - the temperature interval of heating of a blank for rolling should not lead to coarsening of the starting SMC structure;
- 2 - the SMC material should possess the required ductility for rolling at lower temperatures;
- 3 - it is necessary to form strong basal texture providing isotropic properties in sheet plane.

SMC sheet processing route consists in: 1) production of a blank for rolling with submicron-grained microstructure via multi-step forging, 2) and its following warm rolling to a sheet.

Determination of the temperature range of warm rolling

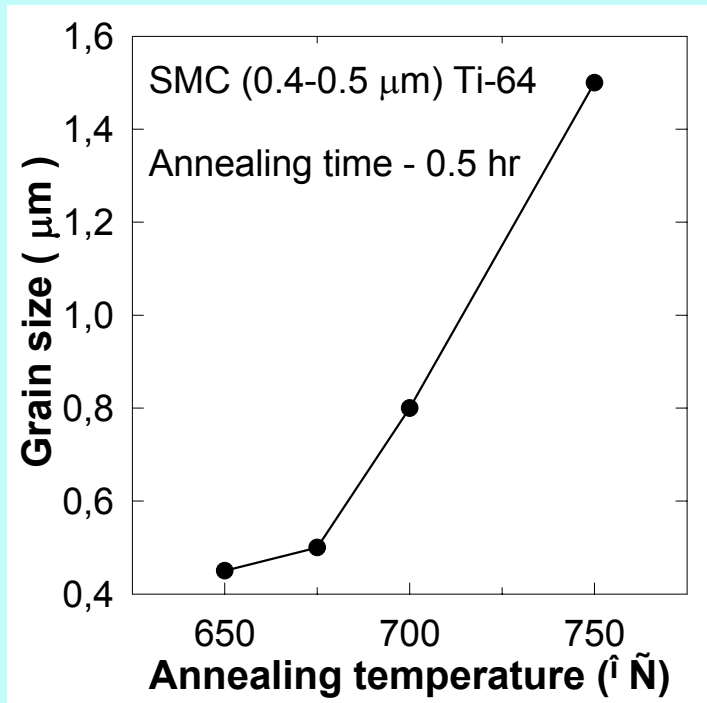

Dependence of grain size of SMC Ti-64 alloy on annealing temperature.

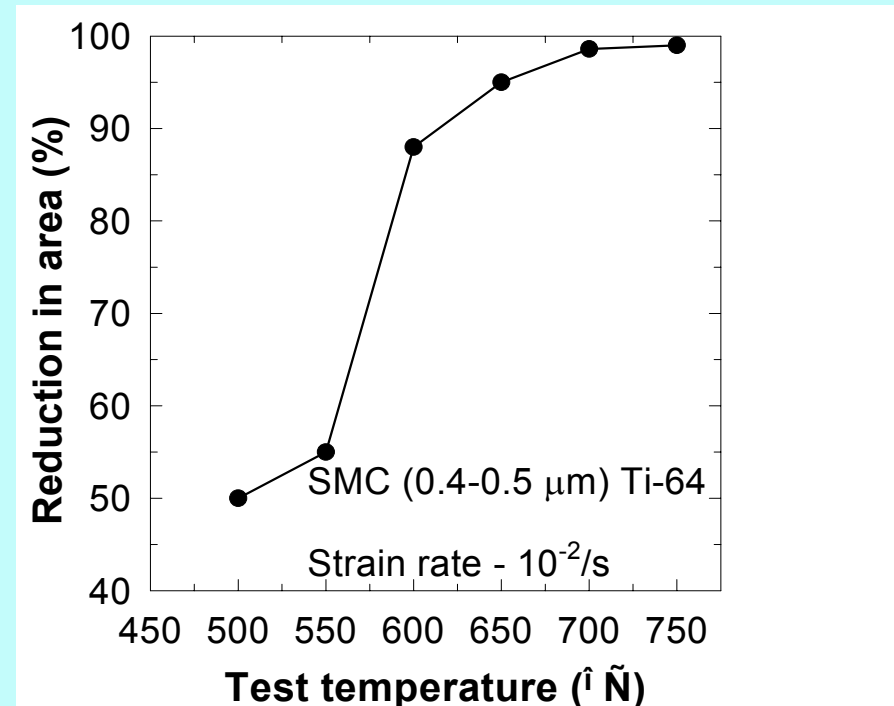

Dependence of reduction in area of SMC Ti-64 alloy on test temperature.

At temperatures above 675–700°C there occurs an intense grain growth. The annealing at 700°C during 1 hr leads to grain growth up to micron-sized condition. At temperatures below 600°C a ductility of SMC material decrease essentially. Consequently, rolling of a blank with SMC structure should be carried out in the temperature range of 600–700°C.

Effect of thermo-mechanical regimes of warm rolling on texture formation

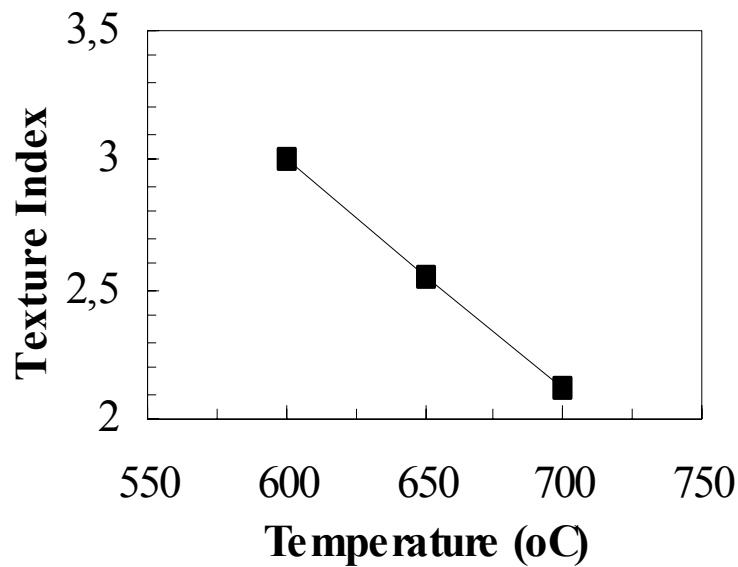

Dependence of texture index on temperature of rolling at 90 % reduction.

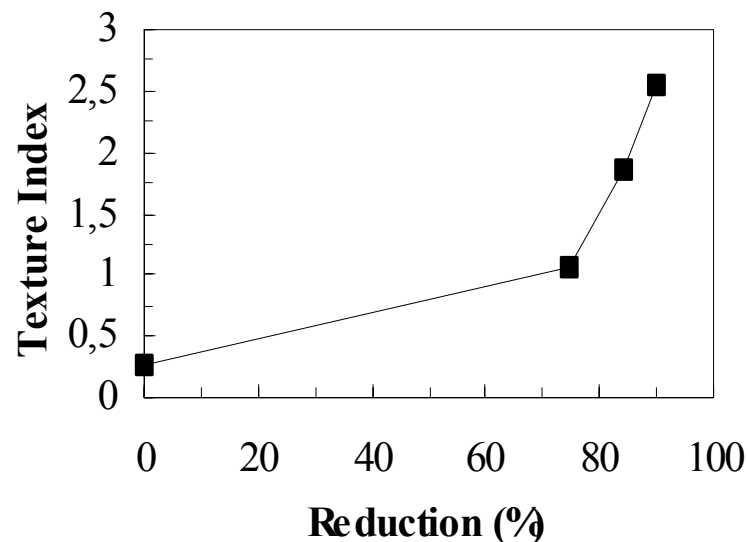

Dependence of texture index on rolling reduction at 650°C.

The intensity of a basal texture component rises with decreasing temperature of sheet rolling, and with increasing rolling reduction of sheet. The strong basal texture should promote isotropic mechanical properties of the sheet in the rolling plane

Commercial-size submicron-grained Ti-64 sheet



Warm rolled sheet, 500mm×1500mm×2mm thick

Characterization of SMC Ti-6Al-4V Sheet

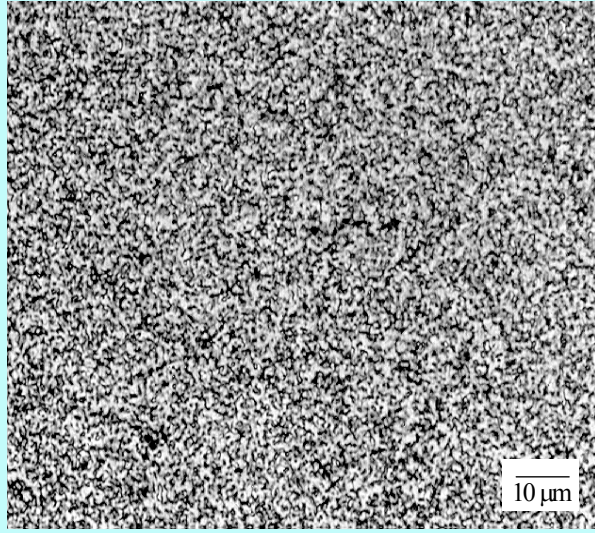

Longitudinal C/S

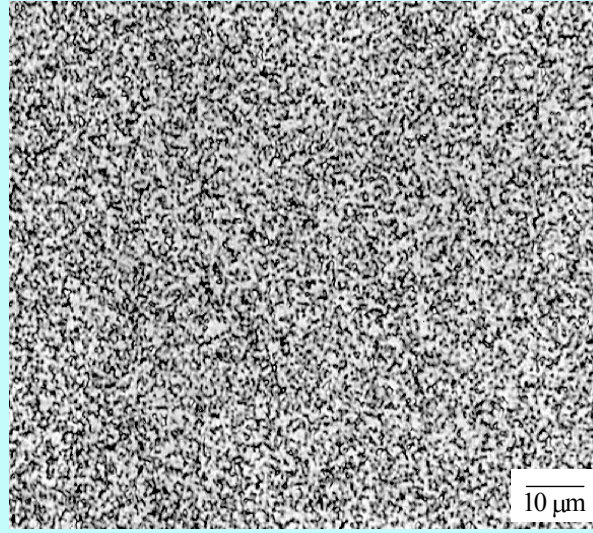

Transverse C/S

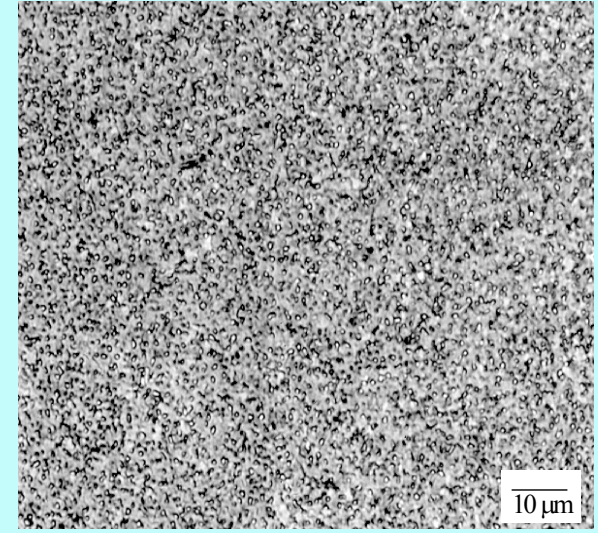

Surface

Optical photomicrographs show the microstructure in three different directions of SMC sheet.

The sheet has a homogenous microstructure.

Room temperature mechanical properties of Ti-64 sheets

Sheet type	Direct ion	YS [MPa]	UTS [MPa]	EL [%]
Laboratory scale SMC sheet that is 0.8 mm thick	RD	1182	1229	8.9
	TD	1190	1238	7.4
Commercial size SMC sheet that is 0.8 mm thick	RD	1022	1159	13
	TD	1022	1160	10
Commercial size SMC sheet that is 2 mm thick	RD	1068	1185	13
	TD	1033	1124	10
Conventional sheet that is 0.7 mm thick	RD	969	1051	11.0
	TD	1022	1071	11.4
AMS 4911H Requirements		870	920	10

Low Temperature Superplasticity of Ti-64 SMC Sheet

T, °C	Strain rate (1/s)	Flow stress (MPa)			Elongation (%)		
		Tensile direction relative to the sheet rolling direction, degree					
		0	45	90	0	45	90
650	7×10^{-4}	70	71	71	780	830	810
	7×10^{-3}	179	180	184	720	660	680
	3×10^{-2}	315	317	310	250	230	270
700	7×10^{-4}	44	48	46	900	910	900
	7×10^{-3}	110	111	118	890	900	900
	3×10^{-2}	165	165	165	550	570	600
750	7×10^{-4}	27	26	29	1000	970	960
	7×10^{-3}	95	85	81	1200	1000	1100
	3×10^{-2}	151	146	147	500	520	500

High isotropy of superplastic properties is observed. The SMC specimens deformed at 750°C and strain rate of 7×10^{-4} /s show the flow stress (27-29 MPa) typical to the alloy with a microcrystalline structure at 875°C.

Summary

1. Mechanical behavior and evolution microstructure of titanium and alpha/beta Ti-6Al-4V titanium alloy at SMC structure conditions by “abc” deformation was studied. The key role of strain localization in macroscopic scale bands for refining microstructure was shown. Structure changes within macrobands, their evolution and relationship with the SPD process were investigated. Macroscopic and microscopic scales of deformation are connected via mesoscopic scale processes. In titanium the structure evolution occurs via self-organization of dislocations in deformation induced high angle boundaries, the interaction of which at their intersection resulted from a change in the strain path leads to formation of submicron-grained structure and strengthening. In two-phase alloy there takes place formation of shear bands, dividing plates of phases into fragments, which afterwards are spheroidized due to formation of high angle grain boundaries and transformation of semicoherent interphase boundaries to noncoherent ones. In this case the mesoscopic scale deformation is determined by cooperative grain boundary sliding leading to superplastic flow and softening.

S u m m a r y

2. The methods of production of large-scale billets and sheets with submicrocrystalline structure were developed. It was shown that billets and sheets possess a high homogeneity of structure and mechanical properties.

The refined grain size in large-scale billets and sheets provided a substantial increase in strength without a loss in ductility.

Submicron-grained sheets demonstrate high superplastic properties at reduced temperature range of 650-750°C. The Ti-64 sheets with SMC structure can be successfully used for SPF and SPF/DB applications with significantly decrease in operations temperature (by ~200°C)