

REPORT DOCUMENTATION PAGE

Form Approved
OMB NO. 0704-0188

Public Reporting burden for this collection of information is estimated to average 1 hour per response, including the time for reviewing instructions, searching existing data sources, gathering and maintaining the data needed, and completing and reviewing the collection of information. Send comment regarding this burden estimate or any other aspect of this collection of information, including suggestions for reducing this burden, to Washington Headquarters Services, Directorate for Information Operations and Reports, 1215 Jefferson Davis Highway, Suite 1204, Arlington, VA 22202-4302, and to the Office of Management and Budget, Paperwork Reduction Project (0704-0188,) Washington, DC 20503.

1. AGENCY USE ONLY (Leave Blank)		2. REPORT DATE 26 August 2004	3. REPORT TYPE AND DATES COVERED Technical Report (May 2003-May 2004)
4. TITLE AND SUBTITLE Military Solid Waste Reformer: A Pilot Study to Convert Military Waste to Logistics Fuel in the Field		5. FUNDING NUMBERS DAAD1903C0058	
6. AUTHOR(S) Duane B. Myers, Gregory D. Ariff, John S. Lettow			
7. PERFORMING ORGANIZATION NAME(S) AND ADDRESS(ES) Directed Technologies, Inc. 3601 Wilson Blvd., Suite 650 Arlington, VA 22201		8. PERFORMING ORGANIZATION REPORT NUMBER	
9. SPONSORING / MONITORING AGENCY NAME(S) AND ADDRESS(ES) U. S. Army Research Office P.O. Box 12211 Research Triangle Park, NC 27709-2211		10. SPONSORING / MONITORING AGENCY REPORT NUMBER 45477.1-CH	
11. SUPPLEMENTARY NOTES The views, opinions and/or findings contained in this report are those of the author(s) and should not be construed as an official Department of the Army position, policy or decision, unless so designated by other documentation.			
12 a. DISTRIBUTION / AVAILABILITY STATEMENT Approved for public release; distribution unlimited.		12 b. DISTRIBUTION CODE	
13. ABSTRACT (Maximum 200 words) The Military Solid Waste Reformer project was a laboratory validation of conventional gasification and/or pyrolysis processes for the conversion of military field waste to liquid fuels in the field. Our approach to solve the military waste disposal and fuel supply problems was to convert the waste to a liquid fuel that can be used in place of or blended with conventional logistic fuels, particularly JP-8. Thus the logistics, fiscal, and environmental burdens were simultaneously addressed. Representative polymer wastes (polyethylene, polypropylene, and polystyrene) were converted to liquid hydrocarbons using a zeolite-catalyzed pyrolysis process at temperatures ranging from 350C-425C. The liquid fuel produced from the mixed plastic waste was similar to JP-8 both in distribution of carbon number and heating value. The composition of the pyrolysis liquids depended strongly both on the type of catalyst and on the feedstock composition. Batch production of liquid fuel for electricity generation was selected as the basis for a detailed conceptual process design. The manufacturing cost of trailer-mounted batch mixed plastic to liquid fuel conversion systems was estimated at low (10 units) and high (10,000 units) production levels. The resulting payback period from avoided fuel costs with typical JP-8 powered generator operation is approximately six months.			
14. SUBJECT TERMS waste conversion, energy, power, recycling, military sustainability, logistics fuel, fuel, polymer		15. NUMBER OF PAGES 71	16. PRICE CODE
17. SECURITY CLASSIFICATION OR REPORT UNCLASSIFIED	18. SECURITY CLASSIFICATION ON THIS PAGE UNCLASSIFIED	19. SECURITY CLASSIFICATION OF ABSTRACT UNCLASSIFIED	20. LIMITATION OF ABSTRACT UL

NSN 7540-01-280-5500

Standard Form 298 (Rev. 2-89)
Prescribed by ANSI Std. Z39-18
298-102

Enclosure 1

**Military Solid Waste Reformer:
A Pilot Study to Convert Military Waste to Logistics Fuel in
the Field**

Final Technical Report

Submitted to:
Army Research Office
and
DARPA Defense Sciences Office

ARO Contract DAAD19-03-C-0058

Principal Investigator:

Duane B. Myers
Directed Technologies, Inc.
3601 Wilson Blvd., Suite 650
Arlington, VA 22201

Phone (703) 243-3383

Fax (703) 243-2724

Duane_Myers@DirectedTechnologies.com

Co-Authors:

Gregory D. Ariff and John S. Lettow

August 2004

EXECUTIVE SUMMARY

Two problems that complicate military logistics in both war- and peace-time are supplying fuel and disposing of trash and sewage. Military forces in the field currently supply electricity using generators powered by logistic fuels (e.g., JP-8), with a typical fuel usage of one gallon every four hours. At the same time, a force of 6,000 men generates several tons per day of trash just from MRE packaging materials. If the solid waste from the soldiers were chemically converted to liquid fuels, it would be possible for a brigade (~3500 soldiers) to support most or all of its electricity generation needs (~1.2 MW) with no outside supply of fuel (depending on conversion process and waste characteristics).

Our approach to solve the military waste disposal and fuel supply problems is to convert the waste to a liquid fuel that can be used in place of or blended with conventional logistic fuels, particularly JP-8. Thus the logistical, fiscal, and environmental burdens described above are simultaneously addressed. The objectives of the seedling project are:

- Characterize the potential waste streams that could be used as feedstocks, including cellulose fluff, plastic waste, and biopolymers.
- Screen the potential conversion processes and verify the operating conditions and the expected product yields and properties in the lab.
- Design a process at the scale of military generators that applies the most efficient conversion demonstrated in the lab. The process design will include a flow sheet with operating conditions and a bill-of-materials. The bill-of-materials will be used to estimate the manufacturing cost for the waste-to-fuel converter.

Aqueous-phase gasification was the initial focus of the waste-to-fuel conversion idea, with pyrolysis as a secondary option. It quickly became apparent, however, that the characteristics of the aqueous-phase gasification process were not compatible with the goal of producing a liquid fuel, or even with the modest goal of delivering net energy from the waste. We could have decided to focus on aqueous phase gasification but supply fuel gases for fuel cells, since the gas product has too low a volumetric energy density to combust in commercial gas-powered generators. The aqueous phase gasification process may be feasible for providing fuel gas for fuel cells, however, the gas is not easily stored or transported. Additionally, the date for adoption of fuel cell technology for military electricity generation is highly uncertain. We concentrated on producing liquid fuel that could be used in either conventional internal combustion generators or in fuel cells having a pre-reforming step. Logistics-fuel compatible liquid fuels could be blended and stored with conventional fuels and used in vehicles or other devices, thus allowing the greatest flexibility and compatibility.

The experimental phase of project was split into three subtasks:

- Analysis of the feedstocks tested
- Screening of the processing conditions and feedstocks in a tubular reactor
- Process optimization in a stirred-tank reactor

“Cellulose fluff” (composted base trash) was collected at Ft. Benning as part of a recycling program conducted by the Army Corps of Engineers, and the results from the fluff analysis are listed in Table ES- 1. The nitrogen and sulfur levels in the fluff were relatively low but may result in a problem when the waste is converted into a gas or a liquid fuel. Nitrogen and sulfur accelerate reactions in liquid fuels that lead to gum formation and reduced engine performance. Gasification processes would produce NH₃ or NO_x from the nitrogen and H₂S or SO_x from the sulfur, all of which can increase materials corrosion rates. Additionally, if the fuels were used in a fuel cell, sulfur and nitrogen compound are potential poisons for the fuel cell catalysts.

Table ES- 1. Elemental analysis and basic properties of Ft. Benning “cellulose fluff.”

Elemental Analysis	Mass Percent (dry basis)
Carbon	41.36
Hydrogen	5.74
Oxygen	33.25
Nitrogen	0.95
Sulfur	0.22
Other (minerals, metals, etc.)	18.48
Moisture	21.20% (mass)
Ash	17.02% (mass)
Heat of combustion (dry basis)	6875 Btu/lb (15.9 MJ/kg)

The mixed plastic feedstock was prepared with 1/3 each of polyethylene (PE), polypropylene (PP), and polystyrene (PS). The polymers for the mixed feedstock experiments were obtained from Goodfellow, with the powder particle sizes matched as closely as possible. The particle sizes were matched to reduce the effects of mass transfer on the pyrolysis reaction rate. The polymer properties for the PE, PP, and PS are listed in Table ES- 2.

Table ES- 2. Polymer properties for mixed plastic feedstocks. M_w and particle size are manufacturer’s specs. Heat of combustion and loss on drying by Galbraith Laboratories.

	Polyethylene (LDPE)	Polypropylene	Polystyrene
Molecular weight	~400,000	~280,000	M _w 280,000 M _n 130,000
Mean particle size, μm	1,000	500	900
Heat of combustion	19,785 Btu/lb (46.1 MJ/kg)	19,959 Btu/lb (46.3 MJ/kg)	17,889 Btu/lb (41.5 MJ/kg)
Loss on drying (mass %)	<0.13	<0.13	4.95

Tubular reactor experiments were used to represent a packed-bed reactor configuration. The tubular reactor setup was also used for screening experiments because it was rated for operation at higher temperatures than the batch reactor. A diagram of the experimental setup is shown in Figure ES- 1. Cellulose fluff and polypropylene pyrolysis were tested in the tubular reactor.

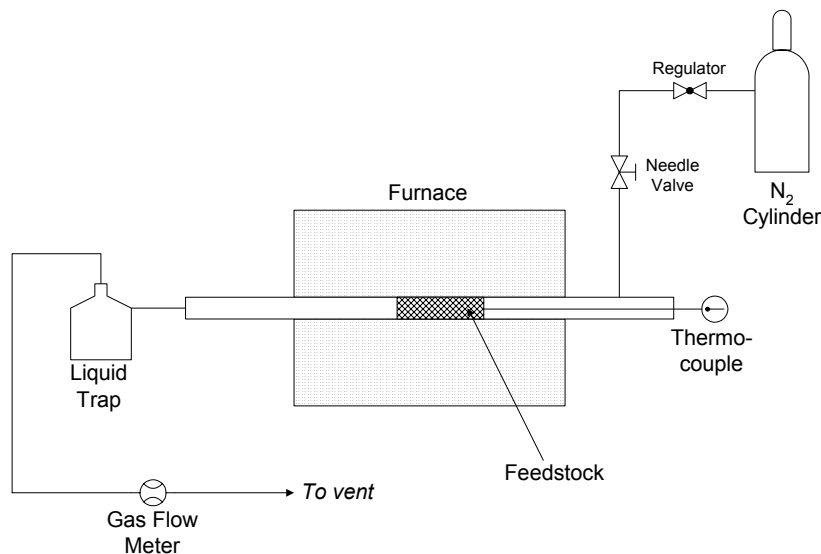

Figure ES- 1. Tubular reactor laboratory process configuration.

Relatively low conversion (<55%) and low oil yield (<24%) was observed for the cellulose fluff pyrolysis, eliminating the cellulose fluff as a potential feedstock for liquid fuel generation. The high gas yields allow for the possibility that fluff pyrolysis could be used to produce a gaseous-fuel for a modified conventional generator or a fuel cell. Because of the low potential for liquid fuel recovery from the mixed cellulosic waste, the project focus was shifted to conversion of plastic wastes to fuel. The polypropylene pyrolysis experiments yielded relatively high conversion (>60%) with commercially-available HZSM-5 catalyst. Although the oil yields were not high in the tubular experiments (<28%), the apparent high quality of the oil and reasonable decomposition temperatures gave confidence that the concept of polymer pyrolysis had the potential for producing useful liquid fuels. The catalyst and polymer were not well-mixed in the tube reactor, so it was hoped that switching to a stirred reactor would improve the liquid yields and feedstock conversion.

The batch catalytic pyrolysis experiments were conducted in a 100 mL agitated stainless steel Parr cylinder reactor rated for operation up to 500°C and 5,000 psig, with the process flowsheet shown in Figure ES- 2. No cooling capability was included in the reactor since the processes being studied were expected to be endothermic or thermally neutral after startup.

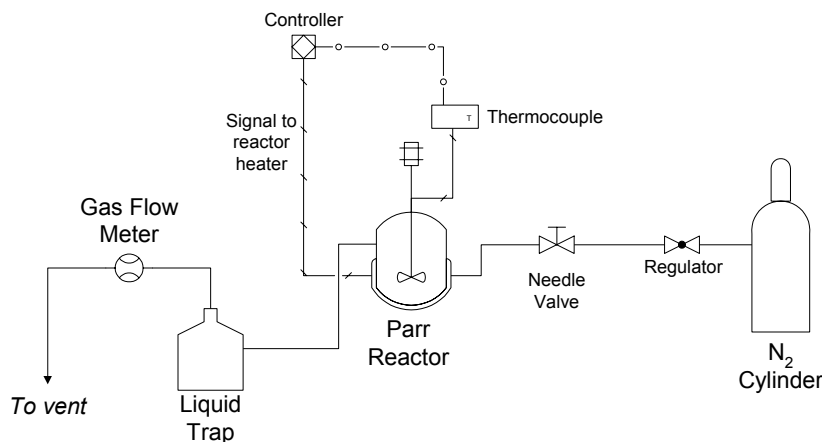

Figure ES- 2. Process flow diagram for the laboratory-scale pyrolysis reactor system.

The pyrolysis gas production was monitored throughout the experiments by recording the cumulative flow rate (as N₂) and correcting the flow using the estimated properties of the gas. In tests for which gas samples were collected and analyzed, the actual gas properties were used for the flow correction. The baseline N₂ flow rate measured during the 110°C purge step was subtracted from the flow measured during reaction. The gas production rate was used as a proxy indicator of the reaction rate, so a plot of instantaneous gas production versus time was assumed to be a valid representation of relative rate of reaction.

A set of screening experiments were conducted with polypropylene feedstock to narrow the range of temperatures, catalyst loadings, and pressure. The baseline process conditions chosen for detailed study with mixed plastic feedstocks were 400-425°C, ~2wt% catalyst loading (based on initial feedstock mass), and ambient pressure. Both commercially available HZSM-5 and mordenite catalysts were tested. The liquid fuel produced from the mixed plastic waste, although not identical to JP-8, is similar both in distribution of carbon number and heating value to JP-8. The most important characteristic for the waste-derived fuel (WDF) will be the compatibility with the existing generator engines, which depends primarily on the heat of combustion, density, and possibly the cetane index compared to JP-8. These and other properties of interest for JP-8 and the corresponding values for the plastic-derived pyrolysis liquids are listed in Table ES- 3 and Table ES- 4. As shown in Table ES- 4, the composition of the pyrolysis liquids depends strongly both on the type of catalyst and feedstock. Singly substituted isoparaffins such as methylnonane (the primary component in the mordenite liquids) have a high cetane index and low octane number, in contrast to multiply substituted isoparaffins which tend to have a low cetane index and high octane number. The high aromatic content of the fuels from the HZSM-5 catalyst lead to poor performance in a diesel engine, but excellent performance (i.e., high octane number) in a gasoline engine. The HZSM-5 liquids are virtually indistinguishable from standard unleaded gasoline and potentially could be blended with logistics fuels if the volumes of waste derived fuel are small relative to the total fuel usage or if gasoline-powered equipment were available.

Table ES- 3. Comparison of pyrolysis liquid product properties with JP-8 specifications.

Property	JP-8 Spec	Mixed Plastic, Mordenite Catalyst 425°C	Mixed Plastic, Mordenite Catalyst 400°C	Mixed Plastic, HZSM-5 catalyst 400°C
Aromatics (vol%)	≤ 25	13.5	8.9	29.3
Naphthalenes (vol%)	≤ 3	0.145	0.085	0.45
Sulfur (ppmw)	≤ 3,000	0	0	0
Density (g/L)	775-840	841	842	883
Net heat of combustion (MJ/kg)	≥ 42.8	44.0	44.0	40.6-43.2
API Gravity	37-51	36	37	30
Approx. Chemical Formula	C ₁₁ H ₂₂	C ₁₀ H _{20.6}	C _{9.8} H ₂₀	C ₉ H ₁₇
Research octane number	N/A	64	59	80
Cetane index	~45	36-68	35-67	N/A

Table ES- 4. Summary of plastic waste-derived fuel compositions.

Mass%	Mixed Plastic, Mordenite Catalyst 425°C	Mixed Plastic, Mordenite Catalyst 400°C	Mixed Plastic, HZSM-5 catalyst 400°C
Paraffins	29.4	23.6	23.8
Isoparaffins	39.4	46.5	22.3
Aromatics	10.3	8.9	31.1
Naphthenics	9.2	9.1	12.5
Olefins	7.9	8.4	7.4
Unknowns/C ₂₆₊	3.7	3.6	2.9

The gas products from pyrolysis may provide a second valuable fuel. The properties of the gas products from plastics pyrolysis are similar to natural gas liquids or butane, so the gas could be easily converted to a compressed liquid for compact storage. The nitrogen sweep gas used in the laboratory apparatus acts as an inert diluent, so in actual practice, the “gas phase” components may be collected as liquid.

Batch production of liquid fuel for electricity generation was selected as the basis for a detailed process design. The batch system is well-adapted to small-scale, intermittent operation, and the use of liquid fuels for electricity production is compatible with existing military generator systems. Continuous systems would have a slight efficiency advantage, but if the waste conversion process were operated for only a fraction of time, startup and shutdown activities would consume a significant fraction of the recovered energy.

The manufacture of trailer-mounted batch mixed plastic to liquid fuel conversion systems was considered at two production levels: 10 units and 10,000 units. The costs for production of the converter units were estimated using modified Design for Manufacturing and Assembly (DFMA) techniques. The DFMA approach has been adapted by Directed Technologies to estimate manufacturing costs for similar conceptual systems related to energy conversion or fuel cells. The estimated costs for the batch waste converter at both production levels are listed in Table ES- 5. At a fuel cost of \$18/gallon in the field (brigade location), with widespread adoption (10,000 unit production run) the simple payback period for the waste converter is ~6 months (assuming 50% average output for the typical 5kW generator).

Table ES- 5. Estimated costs for plastic waste-to-fuel converter at low (10 units) and high (10,000 units) production levels.

Subsystem	Cost at Production Level	
	10 units	10,000 units
Feedstock handling	\$7,904	\$6,535
Processor	\$8,542	\$4,406
Product handling	\$1,940	\$1,436
Instruments and controls	\$508	\$428
Support and exterior	\$995	\$730
Trailer	\$390	\$300
Final assembly	\$1,122	\$561
Cost contingency (20%)	\$6,677	\$4,279
Total	\$28,079	\$18,675

Of course, the economics of the waste-to-fuel conversion are more complicated than the simple payback calculation. The military field waste-to-fuel converter needs to be considered in the context of all logistics operations, including waste handling, fuel delivery, and electricity generation. The decision about what waste feedstocks to use, whether to use a batch or continuous converter, and what properties of the fuels are most critical are all inter-related. For example, if the waste-derived fuels are used to generate electricity immediately after the conversion step, then the fuel stability requirements and all property spec related to fuel stability could be relaxed.

The experiments detailed in this report demonstrate that producing logistics-compatible fuels from plastic waste streams is feasible with conventional thermal processing and that the yields and fuel quality are relatively high with reasonable-cost equipment. There are factors that remain to be optimized and could benefit from additional study, including:

- Choice of catalyst to yield narrow range of fuel properties or flexibility with varied waste feedstocks.
- Linking the fuel generation to the electricity production to achieve higher overall efficiency.

The ability to influence the fuel properties simply by using a different commercially-available zeolite catalyst is an important factor that can be exploited in a scaled-up system. The simple switch from HZSM-5 to mordenite, both commercially available inexpensive catalysts, resulted in a dramatic shift in fuel composition. The high-quality fuels generated using mordenite and HZSM-5 catalysts gives confidence to the possibility of identifying a commercial catalyst for conversion of simple mixed plastic waste mixtures without embarking on an extensive catalyst design program.

A demonstration of a full-scale *stationary* process would be the logical next step. A stationary system would be easier to construct and modify in a development mode than would a trailer-mounted system. Segregated plastic wastes may be available at a military base that operates a waste recycling program, allowing for more real-world tests of the process capabilities.

TABLE OF CONTENTS

1	Introduction	1
1.1	Problem	1
1.2	Technical Approach	1
1.3	Technical Background	2
1.3.1	Waste Generation and Composition	2
1.3.2	Waste Conversion Processes	4
1.3.3	Waste Conversion Process Down-Selection	5
1.4	Feedstock and Catalyst Selection	6
1.5	Fuel Target Properties	7
2	Experimental Results	8
2.1	Feedstock Analysis	8
2.2	Tubular Reactor Experiments	10
2.2.1	Cellulose Fluff Experimental Results	11
2.2.2	Polypropylene Experimental Results	13
2.3	Batch Reactor Experiments	15
2.3.1	Polypropylene Experimental Results	17
2.3.2	Mixed Plastic Experimental Results	23
2.3.3	Cellulose Fluff and Polyhydroxybutyrate Experimental Results	33
2.4	Pyrolysis Summary and Discussion	34
2.5	Fuel Quality and Engine Performance	36
3	Process Analysis and Design	39
3.1	Batch Process for liquid-fueled IC Genset	39
3.1.1	Process Description	39
3.1.2	System Design and Cost	41
3.2	Alternative Processes	44
3.2.1	Batch Process for Gas-fueled IC Genset	44
3.2.2	Continuous Processes	45
4	Conclusions and Recommendations	47
4.1	Laboratory Validation of Plastics-to-Fuel Conversion	47
4.2	Process Design and Cost	48
4.3	Recommendations	50

LIST OF FIGURES

Figure 1. Ft. Benning cellulose fluff.	6
Figure 2. Tubular reactor laboratory process configuration.	10
Figure 3. GC/MS results for PP pyrolysis oil plotted by boiling point range. The black diamonds are the compounds identified in the GC/MS trace. The vertical lines represent the boiling points of the corresponding n-alkanes or aromatics.	14
Figure 4. Process flow diagram for the laboratory-scale pyrolysis reactor system.	15
Figure 5. Parr reactor apparatus. The liquid product trap and gas flow meter are to the right of the reactor stand.	16
Figure 6. Polypropylene pyrolysis gas production at 350°C with ~9wt% HZSM-5 catalyst.	18
Figure 7. Gas production from pyrolysis of polypropylene at 350°C with varying levels of HZSM-5 catalyst. The 2.2% and 9.3% curves are composites of multiple runs.	20
Figure 8. Distribution of products by carbon number in the pyrolysis liquid product from polypropylene feedstock with HZSM-5 catalyst. [analysis by SPL, Inc.].....	22
Figure 9. Mixed plastic pyrolysis gas production with 2.4±0.1 wt% HZSM-5 catalyst as a function of reactor temperature.	23
Figure 10. Average gas production from pyrolysis of mixed plastic waste at 400°C with 2.3wt% HZSM-5 catalyst.	24
Figure 11. Distribution of products by carbon number in the pyrolysis liquid product from mixed plastic feedstock with HZSM-5 catalyst. [average of two analyses by SPL, Inc.]	26
Figure 12. Pyrolysis gas production rate at 400°C with 2.5wt% HZSM-5 catalyst and repeat use of the same catalyst for three consecutive tests.....	27
Figure 13. Distribution of products by carbon number in the pyrolysis liquid product from mixed plastic feedstock with repeated use of HZSM-5 catalyst. [analysis by SPL, Inc.]	29
Figure 14. Pyrolysis gas production from mixed plastic feedstock with mordenite (dashed green line) and HZSM-5 (solid blue line).	29
Figure 15. Distribution of products by carbon number in the pyrolysis liquid product from mixed plastic feedstock with mordenite and HZSM-5 catalysts. [analysis by SPL, Inc.]	31
Figure 16. Distribution of products by carbon number in the pyrolysis liquid product from mixed plastic feedstock with mordenite catalyst at 425°C and 400°C. [analysis by SPL, Inc.].....	32
Figure 17. Pyrolysis gas production with HZSM-5 catalyst at 400°C from cellulose fluff (dashed olive line) and mixed plastic feedstock (solid blue line). The catalyst levels were 9wt% for the cellulose fluff and 2.5wt% for the mixed plastic.	33
Figure 18. Schematic of basic system for batch processing.....	40
Figure 19. Detailed system diagram for batch processing for liquid fuel.	42
Figure 20. Contribution of subsystems to system cost for batch processor for liquid fuel.	44

LIST OF TABLES

Table 1. Composition of Ft. Campbell waste from field feeding operations.....	2
Table 2. MRE packaging composition (1 pallet = 576 MRE).	3
Table 3. Selected JP-8 property specifications.	7
Table 4. Elemental analysis and basic properties of Ft. Benning “cellulose fluff.” [analysis by Galbraith Laboratories].....	8
Table 5. Commercial-grade polypropylene properties (BP Grade 7200P).	9
Table 6. Polymer properties for mixed plastic feedstocks. Molecular weight and particle size are manufacturer’s specs. [Heat of combustion and loss on drying by Galbraith Laboratories].....	9
Table 7. Product yields from cellulose fluff pyrolysis in tubular reactor.	11
Table 8. Metals analysis of cellulose fluff pyrolysis char. Only metals reported above the analytical detection limit are listed in the table. [Galbraith Laboratories]	12
Table 9. Polypropylene pyrolysis experimental results with HZSM-5 catalyst.	14
Table 10. Pyrolysis conversion and oil production from PP with ~9wt% HZSM-5 catalyst as a function of reactor temperature. [Heat of combustion and C-H analysis by Galbraith Labs].....	18
Table 11. Pyrolysis conversion and oil production from PP at 350°C with 2.2wt% HZSM-5 catalyst as a function of reactor pressure.	19
Table 12. Pyrolysis conversion and oil production from PP at 350°C as a function of HZSM-5 catalyst loading.	20
Table 13. Refinery gas analysis of PP pyrolysis with HZSM-5 catalyst gas samples (10- minute composite samples). [analysis by SPL, Inc.]	21
Table 14. Hydrocarbon types present in pyrolysis liquid product from polypropylene feedstock at 350°C with HZSM-5 catalyst. [analysis by SPL, Inc.].....	22
Table 15. Pyrolysis conversion and oil production from mixed plastic with 2.4±0.1 wt% HZSM-5 catalyst as a function of reactor temperature.	23
Table 16. Refinery gas analysis of mixed plastic pyrolysis with HZSM-5 catalyst gas product (12-minute composite sample). [analysis by SPL].....	25
Table 17. Hydrocarbon types present in and properties of pyrolysis liquid product from mixed plastic feedstock with HZSM-5 catalyst. [average of two analyses by SPL, Inc.]	26
Table 18. Oil yields, compositions, and properties for mixed plastic waste pyrolysis at 400°C with 2.5wt% HZSM-5 catalyst, repeat use of the same catalyst with no regeneration. [analysis by SPL].....	28
Table 19. Refinery gas analysis of pyrolysis gas product at 400°C with mordenite catalyst (15-minute composite sample). [analysis by SPL]	30
Table 20. Hydrocarbon types in and properties of pyrolysis liquid product from mixed plastic with mordenite catalyst at 400°C, with HZSM-5 results included for comparison. [analysis by SPL, Inc.]	31
Table 21. Hydrocarbon types present in and properties of pyrolysis liquid product from mixed plastic feedstock with mordenite catalyst at 425°C and 400°C. [analysis by SPL, Inc.]	32
Table 22. Pyrolysis conversion and oil production from cellulose fluff at 400°C with 9 wt% HZSM-5 catalyst.....	34

Table 23. CCAI and CCAI _{mod} values for waste plastic-derived fuels using mordenite catalyst.....	37
Table 24. Process properties for batch production of liquid fuel from mixed plastics. ...	41
Table 25. Bill of materials for batch processor for liquid fuel.	43
Table 26. Process properties for batch process for gas fuel from mixed plastic.....	45
Table 27. Comparison of pyrolysis liquid product properties with JP-8 specifications..	47
Table 28. Summary of plastic waste-derived fuel compositions.	48
Table 29. Pyrolysis gas product compositions.	49
Table 30. Estimated costs for plastic waste-to-fuel converter at low (10 units) and high (10,000 units) production levels.	50

1 Introduction

1.1 Problem

Two problems that complicate military logistics in both war- and peace-time are supplying fuel and disposing of trash and sewage. Military forces in the field currently supply electricity using generators powered by logistic fuels (e.g., JP-8), with a typical fuel usage of one gallon every four hours. At the same time, a force of 6,000 men generates several tons per day of trash just from MRE packaging materials. If the solid waste from the soldiers were chemically converted to liquid fuels, it would be possible for a brigade (~3500 soldiers) to support most or all of its electricity generation needs (~1.2 MW) with no outside supply of fuel (depending on conversion process and waste characteristics).

Logistics fuel is obtained locally when possible. However, if no local supply exists or if the quality of fuel is not consistent, then fuel is transported to the theater of operation from reliable sources in the U.S. or equivalent (e.g., NATO). The Defense Science Board (DSB) has reported that the average cost of fuel delivered by Air Force tanker is \$17.50 per gallon.¹ The Logistics Management Institute (LMI) expanded the DSB cost estimate to include fuel delivery to and waste removal from corps, division, brigade, and battalion positions, with the corps location assumed to be the point-of-entry for the fuel at \$13/gallon.² The value of a gallon of fuel was calculated to be \$17 at the division, \$18 at the brigade, and \$19 at the battalion. The fully-allocated cost of waste removal from the brigade was estimated to be \$820 per ton. In practice, trash in the theater of operations often is burned or buried at the point of generation, creating potential safety and environmental liabilities.

1.2 Technical Approach

Our approach to solve the military waste disposal and fuel supply problems is to convert the waste to a liquid fuel that can be used in place of or blended with conventional logistic fuels, particularly JP-8. Thus the logistics, fiscal, and environmental burdens described above are simultaneously addressed. The objectives of the seedling project are:

- Characterize the potential waste streams that could be used as feedstocks.
- Screen the potential conversion processes and verify the operating conditions and the expected product yields in the lab.
- Design a process at the scale of military generators that applies the most efficient conversion demonstrated in the lab. The process design will include a flow sheet with operating conditions and a bill-of-materials. The bill-of-materials will be used to estimate the manufacturing cost for the waste-to-fuel converter.

¹ Defense Science Board Task Force on Improving Fuel Efficiency of Weapons Platforms Systems. "More Capable Warfighting through Reduced Fuel Burden." January 2001.

² Canes, M.E., C.P. Werle, M.W. Philipp, and S.A. Mosko. *An Analysis of the Energy Potential of Waste in the Field*. Logistics Management Institute Report DRP30T1, February 2004.

The original focus of this seedling effort was on the conversion of present-day military solid waste, and possibly sewage, to liquid fuel to provide a baseline design for a full-fledged DARPA waste-to-fuel program. During the course of the project, the focus of the DARPA program changed to converting specifically *plastic* waste to fuel that could be used in a conventional generator. It became clear that the relatively low energy density and heterogeneity of mixed waste would reduce the chances of efficiently scaling-down a waste-to-liquid fuel process to match the power levels of the majority of military generators (<10kW).

1.3 Technical Background

1.3.1 Waste Generation and Composition

Two surveys of field waste generated during training exercises are available, one from Fort Campbell by the U.S. Army Natick Soldier Center³ (NSC) and one from Fort Irwin by LMI.²

The composition of field feeding waste during operations by four companies, or 210 soldiers total, as measured by NSC over four days at Ft. Campbell is detailed in Table 1. The total feeding waste generated at Ft. Campbell was approximately 0.48 kg per soldier meal. Assuming three meals per soldier per day, the total feeding waste is 1.44 kg per soldier per day.

Table 1. Composition of Ft. Campbell waste from field feeding operations.

Category	Weight Percent
Fiberboard	40.9
Metal	20.2
Food/paper	11.2
Plastic	8.3
MRE	8.0
Paper	4.9
Miscellaneous	3.8
Food	2.4
Glass	0.4
Total convertible	79.4%
Total unconvertible	20.6%

The MRE waste fraction (8wt% of the total at Ft. Campbell) was examined in detail in a separate study by the Natick Soldier Center.⁴ The MRE packaging composition is listed

³ Rock, K, *et al.* *An Analysis of Military Field-Feeding Waste*. Technical Report NATICK TR-00/021, October 2000.

⁴ Kluter, R., *et al.* *A Systems Analysis of Meal, Ready-to-Eat (MRE) Packaging Materials*. Report to Strategic Environmental Research and Development Program (SERDP), September 2002.

in Table 2. The packaging required for handling and shipping the MREs and other supplies adds cellulosic materials not listed in Table 2, including fiberboard (cartons) and wood (pallets).

Table 2. MRE packaging composition (1 pallet = 576 MRE).

Category	Material Type	Weight (kg)
Pallet	Wood	21.3
Pallet straps	Plastic	0.5
Pallet cap	Fiberboard	3.2
Cases	Fiberboard	63.0
MRE	Mixed	94.6
Total weight	182.6 kg	
Weight per soldier per day (assuming 3 MRE meals/day)	1.05 kg/soldier-day	

The waste disposal quantities listed in Table 1 and Table 2 do not account for all of the waste that is generated during operations. LMI obtained waste disposal statistics during two-week training operations at the Ft. Irwin Army National Training Center for five brigades and one battalion representing nearly 23,000 soldiers. Standard practices at Ft. Irwin require that trash must be returned to the installation recycling and disposal facility for weighing and inspection (to ensure that no live munitions or hazardous materials are included). The average waste generated during the training rotations was 3.8 kg/soldier-day. Approximately 3.3 kg/soldier-day was ‘convertible’ material, including paper, plastic, cardboard, and wood. Additionally, LMI estimated the quantity of human waste generated to be ~2 kg per person per day (wet basis).⁵

The Ft. Irwin measurements will be used in this report for calculating the potential recovery of energy from field waste because of the large sample size and realistic operating conditions compared to the Natick Soldier Center studies. If the military waste is assumed to have the energy value (12.7 MJ/dry kg) and moisture content (~20wt%) of U.S. municipal solid waste,⁶ then the potential thermal energy available from waste in a brigade-size force of 4,500 soldiers is 151,000 MJ/day or 1,746 kW_{th}.

Approximately 450 kW of electricity could be generated if the thermal energy from the brigade’s waste were converted in a conventional generator, or slightly more than one-third of the brigade electrical generation capacity of 1,200 kW. However, if the packaging materials were constructed exclusively of petroleum-derived polymers instead of cellulose-based materials like fiberboard and paper, the energy content of the waste would increase to 43 MJ/kg. If 70% of the energy contained in the waste polymer

⁵ Personnel communication with Chris Werle, Logistics Management Institute, August 2003.

⁶ Klass, D.L. *Biomass for Renewable Energy, Fuels, and Chemicals*. Academic Press, San Diego, 1998.

were converted to a liquid fuel and used in the conventional generators, all of the brigade's electrical generation requirements could be met.

1.3.2 Waste Conversion Processes

One of the proposed approaches for converting the waste to fuel was the gasification of the solids from a liquid-phase slurry rather than in a conventional steam or air gasifier, ideally with the water provided by liquid sewage. If no water-based sewage stream is available, water could be provided from another source. Representative biomass gasification reactions in the presence of water are

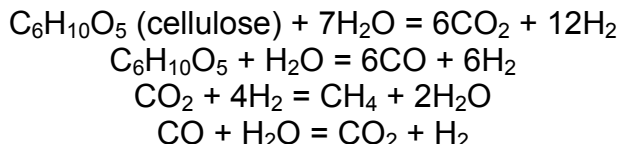

The proposed path to liquid fuels from gasification products was to convert H₂ and CO to methanol using Fischer-Trøpsch synthesis at ~250°C and 50-100 bar. An obstacle to achieving the optimal H₂/CO ratio for methanol production is the relatively high conversion to CO₂ compared to CO in the aqueous-phase reformer due to the high water-to-carbon ratio in the slurry. The calculated maximum methanol yield is approximately 0.6 kg per kg of dry biomass waste. The methanol can be converted to diesel- or gasoline-range hydrocarbons using the MTG process or equivalent.⁷ Traditional Fischer-Trøpsch processes for gas-to-liquids systems are often highly integrated with other refinery-type operations.

Pyrolysis may be a suitable conventional approach to generating liquid fuels from solid waste if water is not available and/or the gasification processes prove to be inefficient or impractical. Pyrolysis has the important feature that it is accomplished at atmospheric or moderate pressures, potentially allowing lower-cost materials of construction for the process equipment. Paper pyrolysis at 500°C yields nearly 50% by mass oil with the balance evenly divided among gas, charcoal, and water.⁸ A potential down-side for pyrolysis of cellulosic materials is that the oil often contains a significant fraction (>20 wt%) of water, leading to reduced heating value and energy density. The liquids may not be compatible with existing fuels like JP-8. Biomass feedstocks can be converted to fuel-compatible liquids, but the processes' complexity and efficiencies limit the practicality for mobile units at small scale.⁹

Polymer pyrolysis produces higher yields of oils than does paper pyrolysis, up to 90% by mass. With no catalyst, Chung, *et al.* observed minimal oil yields from low-density polyethylene (LDPE) and polypropylene (PP) pyrolysis except for temperatures

⁷ Satterfield, C.N. *Heterogeneous Catalysis in Industrial Practice*, 2nd ed. McGraw-Hill, New York, Chapters 7 and 9 (1991).

⁸ Klass, D.L. *Biomass for Renewable Energy, Fuels, and Chemicals*. Academic Press, San Diego, 1998, pp. 225-269.

⁹ *Process for manufacturing fuel from ligno-cellulose material*. European Patent 00366138. March 1994.

>450°C.¹⁰ However, with various aluminosilicates (zeolites, treated coal fly ash), they were able to achieve oil yields approaching 90% at 450°C, with product oil boiling point curves virtually identical to the conventional diesel boiling point curve. Ding, *et al.* reported that HZSM-5 is an active catalyst for the decomposition of high-density polyethylene (HDPE) and post-consumer plastic waste, in a N₂-atmosphere producing a fuel-like hydrocarbon liquid product with yields up to 89%.¹¹ Kaminsky has reported the results of non-catalytic pilot-scale household plastic waste pyrolysis at high temperatures (>680°C).¹² Oil yields of 35-50% were achieved, with the aromatic content of the oil increasing with increasing temperature.

1.3.3 Waste Conversion Process Down-Selection

Aqueous-phase gasification was the initial focus of the waste-to-fuel conversion idea, with pyrolysis as a secondary option. It quickly became apparent, however, that the characteristics of the aqueous-phase gasification process were not compatible with the goal of producing a liquid fuel, or even with the modest goal of delivering net energy from the waste. The deciding factors for concentrating the conversion on pyrolysis include:

- Pyrolysis yield of oil from biomass is at best 50%, from polymer >70%. The production of liquid fuels by aqueous-phase gasification with Fischer-Tröpsch conversion is approximately energy neutral, that is, no net fuel is produced due to the process heat requirements. The generation of useful quantities of liquid fuels from a gasification/ Fischer-Tröpsch process would have required an entirely novel, energy-efficient gas-to-liquids scheme, which was outside the scope of this seedling effort.
- The combined solid waste and human waste streams would contain ~35% moisture, assuming a moisture content of 95% for the human waste and 20% for the convertible fraction of the solid waste. The solids content of a biomass-water slurry must be less than about 10% for the slurry to flow, so 32 kg/person/day (8.4 gallons) of additional water would be required to reach 90% moisture for the combined waste streams. The logistics burden to supply the additional water would be excessive in many locations and, when combined with the inefficiency of the Fischer-Tröpsch process at small scale, eliminates the aqueous phase gasification as a practical option.
- The targeted scale of process, which is for a typical military field electrical generator. A brigade generator allocation is 146 units totaling 1,167 kW. Of the 146 generators, 122 (with 612 kW total rating) are 10 kW or less.¹³ The DARPA MISER concept (for which this process will serve as the conventional baseline) is to link one or a few generators to the waste conversion device. As a result, we focused on waste conversion options that can scale efficiently down to 5 kW electric equivalent.

¹⁰ Chung, S.H., *et al.* "Pyrolysis of Waste Plastics Using Synthesized Catalysts from Fly Ash." In *Proceedings of the 13th U.S.-Korea Joint Workshop on Energy and Environment*, U.S. National Energy Technology Lab, 1999.

¹¹ Ding, W., *et al.* "Thermal and catalytic degradation of high density polyethylene and commingled post-consumer plastic waste." *Fuel Processing Technology* **51** (1997) 47-62.

¹² Kaminsky, W. "Chemical Recycling of Mixed Plastics by Pyrolysis." *Advances in Polymer Technology* **14**:4 (1995) 337-344.

¹³ Personal communication with Chris Werle, Logistics Management Institute, September 2003.

Another conversion pathway that was considered but ultimately rejected was aqueous phase gasification to supply fuel gases for fuel cells, since the gas product has too low a volumetric energy density to combust in commercial gas-powered generators. While the aqueous phase gasification process may be feasible for providing fuel gas for fuel cells, the gas is not easily stored or transported. Additionally, the date for adoption of fuel cell technology for military electricity generation is highly uncertain. We concentrated on producing liquid fuel that could be used in either conventional internal combustion generators or in fuel cells having a pre-reforming step. Logistics-fuel compatible liquid fuels could be blended and stored with conventional fuels and used in vehicles or other devices, thus allowing the greatest flexibility and compatibility.

1.4 Feedstock and Catalyst Selection

There were four sets of feedstocks that were examined in the conversion processes:

- Cellulosic municipal waste from Ft. Benning, Georgia (“cellulose fluff”)
- Pure polypropylene (PP)
- Mixed plastic: 1/3 weight fraction each of polyethylene (PE), polypropylene (PP), and polystyrene (PS)
- Biopolymer: poly-hydroxybutyrate (PHB)

The fluff was the remainder of the Ft. Benning waste after most metal and plastic components were removed for other recycling uses (see Figure 1 for a photograph of the fluff). The cellulose-rich fluff material was tested by the Corps of Engineers as a soil additive (i.e., mulch) to decrease compaction and improve drainage.

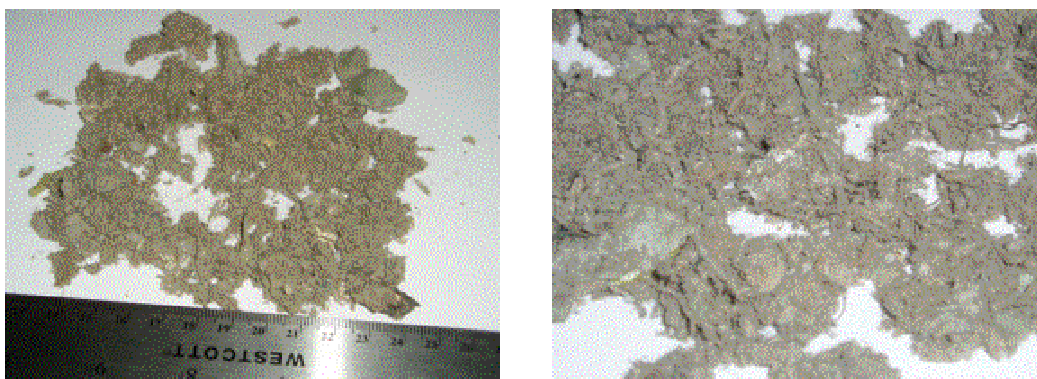

Figure 1. Ft. Benning cellulose fluff.

Commercial-grade polypropylene powder was used to screen process conditions for the plastics pyrolysis since it is inexpensive and was readily available in the DTI laboratory. Mixed plastic (PE, PP, and PS) was tested to represent a “sanitized” version of a representative all-plastic waste stream. Other waste materials such as food particles, metals, and chlorinated polymers (PVC) would be encountered in a real waste stream, but the inconsistencies in real waste could obscure the effect of processing parameters.¹⁴

¹⁴ The mixed plastic waste is the model feedstock for the full MISER program. This seedling work will serve as a baseline representing an innovative design with conventional thermal processing.

The biopolymer poly-hydroxybutyrate was included to determine how a biopolymer would react to the process conditions used for the mixed plastic. There is potentially a long-term trend toward biodegradable plastic materials, and it will be useful to understand if biopolymers can be converted in the same process as the conventional petroleum-based polymers. The PHB was used as a surrogate for the poly-lactic acid (PLA) that was being developed in a parallel seedling project.¹⁵ PHB was more readily available than PLA, and the chemical composition of PHB and PLA differ by only one carbon per repeat unit.

Based on the catalyst literature summarized in Section 1.3, two types of zeolites were used as catalysts for the pyrolysis experiments. HZSM-5 with a silica-to-alumina ratio of 80 and surface area ~400 m²/g was obtained from Zeolyst (product number CBV 8020). Mordenite (H-form) with a silica-to-alumina ratio of 40 and surface area >300 m²/g was obtained from Süd Chemie (product number T-4530-H-MOR 40).

1.5 Fuel Target Properties

The goal of the selected waste conversion process was to produce a fuel that is compatible with the standard military JP-8. The specifications for JP-8 are essentially identical to those for commercial Jet A (except for a few minor additives), so we have used the specs for both JP-8 and Jet A to compile the set of important properties listed below in Table 3. There are a long list of additional specs for JP-8, however, the list in Table 3 covers those properties that potentially could be measured using the laboratory-generated quantities of fuel from this project.

Table 3. Selected JP-8 property specifications.

Property	Typical JP-8 Specifications
Aromatics (vol%)	≤ 25
Naphthalenes (vol%)	≤ 3
Olefins (vol%)	≤ 5
Sulfur (ppmw)	≤ 3,000
Density (g/L)	775-840
Net heat of combustion (MJ/kg)	≥ 42.8
API Gravity	37-51
Approx. Chemical Formula	C ₁₁ H ₂₂ (min. H content C ₁₁ H ₂₀)
Boiling point curve: 10% recovery Final boiling point	205°C 300°C

¹⁵ Brooklyn Polytechnic University.

2 Experimental Results

The experimental phase of the project was split into three subtasks:

- Analysis of the feedstocks tested
- Screening of the processing conditions and feedstocks in a tubular reactor
- Process optimization in a stirred-tank reactor

2.1 Feedstock Analysis

The “fluff” from Ft. Benning was collected as part of a recycling program conducted by the Army Corps of Engineers, and the results from the fluff analysis are listed in Table 4. The analysis was conducted by Galbraith Laboratories (Knoxville, Tennessee). The fluff had been analyzed previously by the Corps of Engineers contractor to determine that there were no hazardous materials present at levels of concern, since the fluff was intended to be used as a surface-applied mulch. Individual and composite samples taken over a two-week period were analyzed for Toxic Characteristic Leachate Procedure (TCLP), for volatile organic content (VOC), and for semi-volatile organic content (SVOC). None of the composite tests revealed levels that would be considered hazardous for land application, although elevated lead and mercury levels were detected in a few samples. The material was considered safe for use with standard laboratory practices.

The nitrogen and sulfur levels in the fluff are relatively low but may result in a problem when the waste is converted into a gas or a liquid fuel. Nitrogen and sulfur accelerate reactions in liquid fuels that lead to gum formation and reduced engine performance. Gasification processes would produce NH_3 or NO_x from the nitrogen and H_2S or SO_x from the sulfur, all of which can increase material corrosion rates. Additionally, if the fuels were used in a fuel cell, sulfur and nitrogen compounds are potential poisons for the fuel cell catalysts.

Table 4. Elemental analysis and basic properties of Ft. Benning “cellulose fluff.” [analysis by Galbraith Laboratories]

Elemental Analysis	Mass Percent (dry basis)
Carbon	41.36
Hydrogen	5.74
Oxygen	33.25
Nitrogen	0.95
Sulfur	0.22
Other (minerals, metals, etc.)	18.48
<hr/>	
Moisture	21.20% (mass)
Ash	17.02% (mass)
Heat of combustion (dry basis)	6875 Btu/lb (15.9 MJ/kg)

The polypropylene used for the screening experiments was a homopolymer powder (BP Chemicals Grade 7200P) typically used for injection molding or extrusion. The properties of the commercial-grade polypropylene are listed in Table 5. The negligible ash content means that there is little if any inorganic fillers in the polypropylene.

Table 5. Commercial-grade polypropylene properties (BP Grade 7200P).

Molecular weight	~250,000 (~6000 monomer units)
Melting temperature range	160-165°C
Heat of combustion (measured)	19,959 Btu/lb (46.3 MJ/kg)
Soot (specification)	7-9%
Ash (measured)	<0.10%
Loss on drying (measured)	<0.13%

The mixed plastic feedstock was prepared with 1/3 each of polyethylene (PE), polypropylene (PP), and polystyrene (PS). The polymers for the mixed feedstock experiments were obtained from Goodfellow, with the powder particle sizes matched as closely as possible. The particle sizes were matched to reduce the effects of mass transfer on the pyrolysis reaction rate. The polymer properties for the PE, PP, and PS are listed in Table 6. The poly-hydroxybutyrate (PHB) biopolymer was obtained from Goodfellow (LS261034).

The PHB has a maximum working temperature of >95°C and a measured heat of combustion of 9,922 Btu/lb (23.0 MJ/kg). The heat of combustion (or heating value) of the PHB is slightly higher than the heating value of biomass materials like paper and is only ½ the heat value of the hydrocarbon-based plastics listed in Table 6.

Table 6. Polymer properties for mixed plastic feedstocks. Molecular weight and particle size are manufacturer's specs. [Heat of combustion and loss on drying by Galbraith Laboratories]

	Polyethylene (Goodfellow LDPE ET316060)	Polypropylene (Goodfellow PP306030)	Polystyrene (Goodfellow ST316090)
Molecular weight	~400,000	~280,000	M _w 280,000 M _n 130,000
Mean particle size, μm	1,000	500	900
Heat of combustion	19,785 Btu/lb (46.1 MJ/kg)	-- ^a	17,889 Btu/lb (41.5 MJ/kg)
Loss on drying (mass %)	<0.13	-- ^a	4.95

^aHeat of combustion and adsorbed moisture are assumed to be the same as the commercial grade PP properties listed in Table 5.

2.2 Tubular Reactor Experiments

The tubular reactor experiments were used to represent a packed-bed reactor configuration. The tubular reactor setup was also used for screening experiments because it was rated for operation at higher temperatures than the batch reactor. A diagram of the experimental setup is shown in Figure 2. The feedstock to be converted was cut into smaller pieces (less than ~0.5 cm) and loaded into a ½" stainless steel tube and supported on a mesh screen. The catalyst (if used) was mixed thoroughly with the fluff or loaded in a second layer downstream of the PP. A thermocouple was inserted to touch the upstream end of the bed. The bed length was determined by the size of the furnace isothermal zone (approximately 10cm). The tube containing the feedstock and the thermocouple was enclosed in a hinged box furnace (Lindberg Blue M), and connected to a nitrogen purge line and a liquid product trap. The vapor outlet from the product trap was routed through a gas flow meter with totalizer (Aalborg GFM171, 0-200 sccm), then vented through a water trap.

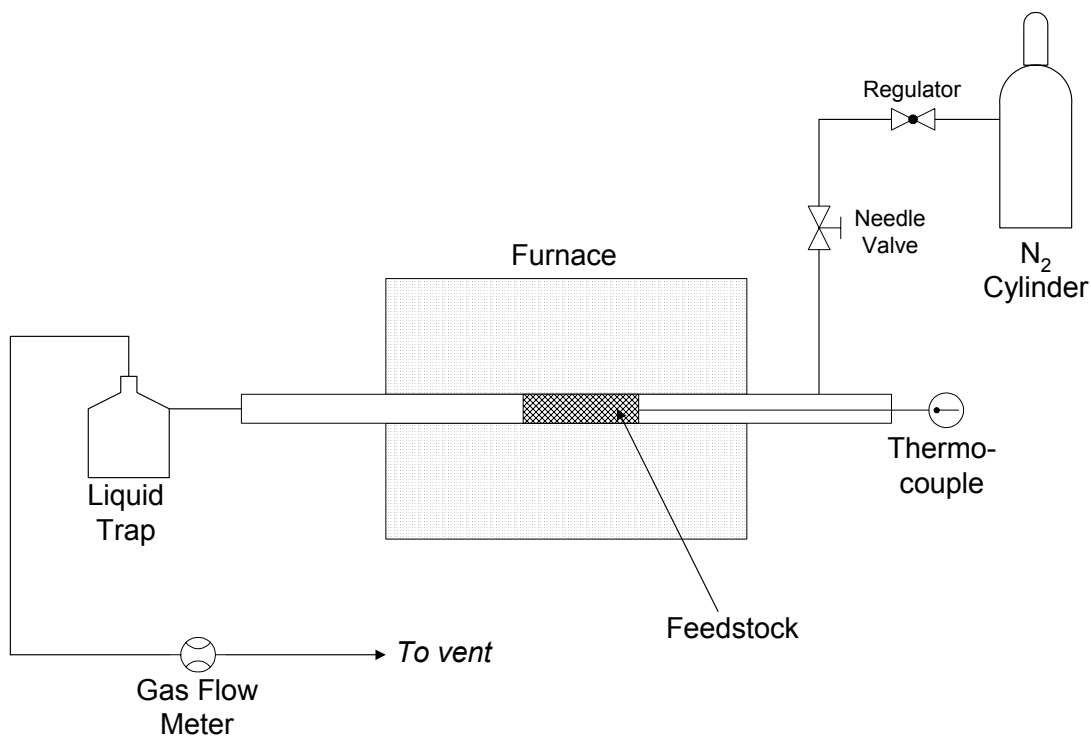

Figure 2. Tubular reactor laboratory process configuration.

The general procedure for a pyrolysis test in the tubular reactor was as follows:

- The reactor was purged with N₂ at ~50 sccm for 20 minutes.
- The furnace temperature was raised to 135°C at a rate of 1-2°C/second with continued N₂ flow.
- The furnace temperature was maintained at 135°C for 1 hour to purge moisture and O₂ from the system and from the feedstock.

- The furnace temperature was increased in 100°C increments, with a 5 minute hold at each interval so that the lag between the external furnace and internal reactor temperatures dissipated.
- When the internal thermocouple reached the desired set point, the furnace output was controlled to maintain that set point. The N₂ purge flow was shut off in some early experiments so that only the pyrolysis gas output was measured in the flow meter. The experimental procedure evolved throughout the course of the project so that the N₂ purge remained on throughout the experiments because the pyrolysis gas flow was not high enough to move the heavier liquid and solid products out of the reaction zone.
- The reactor heat was turned off after the desired reaction time had elapsed (typically 1-4 hours), and the N₂ purge was maintained until the reactor had cooled to <40°C.
- The liquid products were recovered from the trap, and the char residual and solid products were removed from the reactor tube.

The tubular reactor was used for both cellulose fluff and polypropylene pyrolysis screening experiments. The mixed plastic feedstock was not tested in the tubular reactor due to the relatively small quantities of the research-grade polymers that were obtained for the experiments.

2.2.1 Cellulose Fluff Experimental Results

Combined mass balances from the cellulose fluff tubular reactor experiments are listed in Table 7. The “oil yield” includes products that are either liquid or waxy solid at room temperature, and typically the wax mass was about the same as the liquid mass. The wax would not be useful as a generator fuel in most situations, but it was included with the oil fraction since it could potentially be blended with conventional fuel to offset some of the fuel-supply requirement.

Table 7. Product yields from cellulose fluff pyrolysis in tubular reactor.

	Condition A	Condition B	Condition C	Condition D
Temperature (°C)	600	600	600	325
Purge during reaction	none	none	~35 sccm	~50 sccm
Hold time (hours)	1	1	4	2
HZSM-5 Catalyst	0	6.4wt%	0	0
Yield, dry weight basis				
Oil	8.9% ± 4.5%	21%	24%	22%
Gas	37.0% ± 10.4%	34%	33%	13%
Char	54.1% ± 6.8%	44%	44%	65%

A char sample from a Condition A test was analyzed for metals, ash at 900°C, and C-H-N content (Galbraith Laboratories). The full metals analysis results are listed in Table 8. There were 32 metals present at levels above detection limits, with major (off-scale)

quantities of calcium, iron, and sodium. Also present at high levels were magnesium, phosphorous, manganese, copper, zinc, and potassium. The ash content was determined to be 41%, indicating that the pyrolysis char still contained 59% volatile or combustible material. The elemental analysis result for the char was 42.8% carbon, 2.4% hydrogen, and 1.2% nitrogen. The molecular formula corresponding to the char elemental analysis is $C_{1.0}H_{0.66}N_{0.03}$, which indicates that some energy-rich material remained in the char. Typical bituminous coal has a similar molecular formula ($C_{1.0}H_{0.80}N_{0.02}$, excluding oxygen and sulfur) and a heat of combustion of 13,600 Btu/lb.¹⁶

The hold time at 600°C was extended to ~4 hours for the Condition C test to demonstrate the maximum non-catalytic pyrolysis conversion that could be achieved with the fluff. The Condition C result is nearly identical to the Condition B result, demonstrating that the use of a catalyst dramatically improves the rate of pyrolysis. For a given set of process conditions and hold time (Conditions A and B), the catalyst also improved the overall conversion and the oil yield.

Table 8. Metals analysis of cellulose fluff pyrolysis char. Only metals reported above the analytical detection limit are listed in the table. [Galbraith Laboratories]

Element	Level (ppm)	Element	Level (ppm)
Lithium	17	Strontium	100
Magnesium	7305	Yttrium	2
Phosphorous	5434	Zirconium	23
Calcium	Above scale	Molybdenum	9
Scandium	1	Cadmium	6
Titanium	678	Tin	25
Vanadium	9	Antimony	1
Chromium	321	Lanthanum	6
Manganese	1773	Cerium	10
Iron	Above scale	Praseodymium	1
Cobalt	5	Neodymium	7
Nickel	96	Lead	134
Copper	1206	Bismuth	6
Zinc	2600	Thorium	2
Gallium	4	Sodium	Above scale
Rubidium	7	Potassium	5766

One test was conducted at 325°C (Condition D), since typically some oil was formed starting at ~325°C during the initial reactor temperature ramp. It was hypothesized that maintaining the lower temperature would result in a higher oil yield than at the higher temperatures. Although the oil-to-gas ratio for Condition D was higher than for the higher temperature tests, the overall fluff conversion was only 35%, resulting in reduced total oil production.

¹⁶ Perry, R.H. and D. Green, eds. *Perry's Chemical Engineer's Handbook*, 6th ed. 1984, p. 9-5.

A wax sample from Condition A and an oil sample from Condition B were sent to the Georgia Tech Institute of Paper Science and Technology (laboratory of Dr. Art Ragauskas) for qualitative ^1H and ^{13}C NMR analysis. The wax NMR results showed predominantly aliphatic and olefinic hydrocarbons, with no identifiable hydroxyl groups, aromatic carbons, aldehydes, or acid groups. The oil NMR results showed trace amounts of olefinic carbons, some hydroxyl, aliphatic, and possibly acid groups, but no aldehyde or aromatic signals. The NMR traces are included in Appendix A.

The gross heat of combustion of the pyrolysis wax product in Condition C in Table 7 was measured as 14,800 Btu/lb (34.3 MJ/kg). Although the specific energy content of the wax is higher than the energy content of cellulose fluff feedstock, the wax is a solid at room temperature and would not be a useful fuel in conventional generators. The coal-like heat of combustion and chemical composition of the combined wax and char could result in other uses such as space or water heating and cooking.

The relatively low conversion (<55%) and low oil yield (<24%) for the cellulose fluff pyrolysis eliminate the cellulose fluff as a potential feedstock for liquid fuel generation. The high gas yields allow for the possibility that fluff pyrolysis could be used to produce a gaseous-fuel for a modified conventional generator or a fuel cell. Because of the low potential for liquid fuel recovery from the mixed cellulosic waste, the project focus was shifted to conversion of plastic wastes to fuel. The change in focus was in part due to the evolution of the DARPA MISER program targets for which this work will provide a baseline design using conventional waste conversion techniques.

2.2.2 Polypropylene Experimental Results

Commercial grade polypropylene powder was loaded into the tubular reactor in the configuration shown in Figure 2 with the HZSM-5 catalyst (if used) loaded at the downstream end of the PP powder bed. The initial PP experiment was conducted at 600°C with no catalyst. The only products of the non-catalytic pyrolysis were a solid wax (possibly smaller chain PP) and gas, with 26% conversion to gas.

The subsequent test was at identical conditions but with a layer of HZSM-5 catalyst downstream of the PP. The results from three representative PP pyrolysis experiments in a tubular reactor are summarized in Table 9. The 600°C catalytic reaction had overall conversion of 88% with a 26% yield of clear oil with a strong hydrocarbon odor. The reaction temperature was reduced after the initial tests because the homogeneous PP feedstock, as compared to heterogeneous fluff, decomposed uniformly at a single temperature between 450-500°C. The surge of product flow that occurred at the decomposition temperature overwhelmed the separation and collection apparatus, leading to the possibility of incomplete recovery. The differences in conversion and gas-to-oil ratio resulting from variations in the reaction temperature were significant enough to conclude that temperature is a critical control variable. The PP conversion increased from 67% to 88% with a temperature increase from 475°C to 600°C, but the difference in conversion is entirely accounted for by gas production. The PP conversions at 450°C and 475°C were similar, but the oil yield was 2.5-times greater at 475°C.

Table 9. Polypropylene pyrolysis experimental results with HZSM-5 catalyst.

Max Temperature	600°C	475°C	450°C
Catalyst loading (wt %)	21.5	22.3	15.5
Waste mass reduction (wt %)	88	67	60
Oil yield (wt %)	26	28	11
Oil/gas ratio	0.43	0.71	0.23

A sample of the oil from the 600°C catalytic test was analyzed by gas chromatography/mass spectrometry (GC/MS) to identify the components. There were a large number of peaks in the GC trace, with a number of significant peaks not matched with any certainty to the MS component library. However, by fitting a curve to the plot of retention time vs. boiling point for the known compounds, an approximate plot of peak height vs. boiling point was constructed, as shown in Figure 3.¹⁷ Representative alkanes and aromatics are highlighted on Figure 3 to bracket the boiling point range for the sample. The bulk of the PP pyrolysis oil falls in the C₈ to C₁₁ boiling range, which also includes substituted aromatics such as xylenes, ethylbenzene, and trimethylbenzenes.

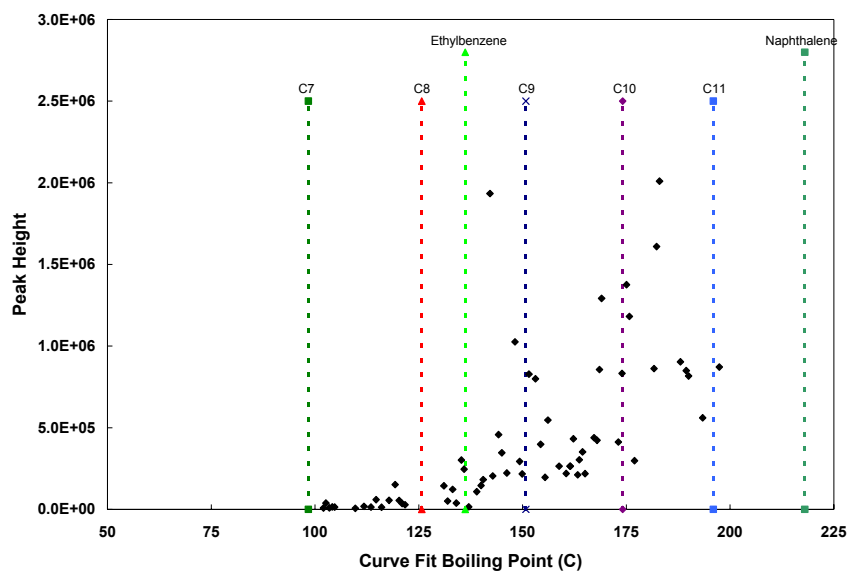

Figure 3. GC/MS results for PP pyrolysis oil plotted by boiling point range. The black diamonds are the compounds identified in the GC/MS trace. The vertical lines represent the boiling points of the corresponding n-alkanes or aromatics.

¹⁷ It was assumed that the trends in GC column retention time and the component boiling points were closely related. The initial GC/MS was used only to demonstrate that fuel-range products were possible from polymer pyrolysis. More quantitative results were obtained in the batch reactor tests (Section 2.3.1).

The components and carbon number ranges identified in the GC/MS analysis match reasonably well to the components and the carbon number ranges in conventional liquid fuels. The GC/MS results confirmed the literature and gave confidence that pyrolysis of plastics was a promising approach for producing liquid fuels.

2.3 Batch Reactor Experiments

The batch reactor experiments were conducted in a 100 mL agitated stainless steel Parr cylinder reactor rated for operation up to 500°C and 5,000 psig. The magnetically-driven agitator was equipped with a 1/8 hp variable speed motor and 600 rpm maximum rotation. The reactor cylinder was heated by a 400-Watt electric band heater with PID temperature control. No cooling capability was included in the reactor since the processes being studied were expected to be endothermic or thermally neutral after startup. A process flow diagram of the Parr setup is shown in Figure 4, and a photograph is shown in Figure 5. The same gas flow meter used in the tubular reactor system was used in the Parr system to measure the gas production rate.

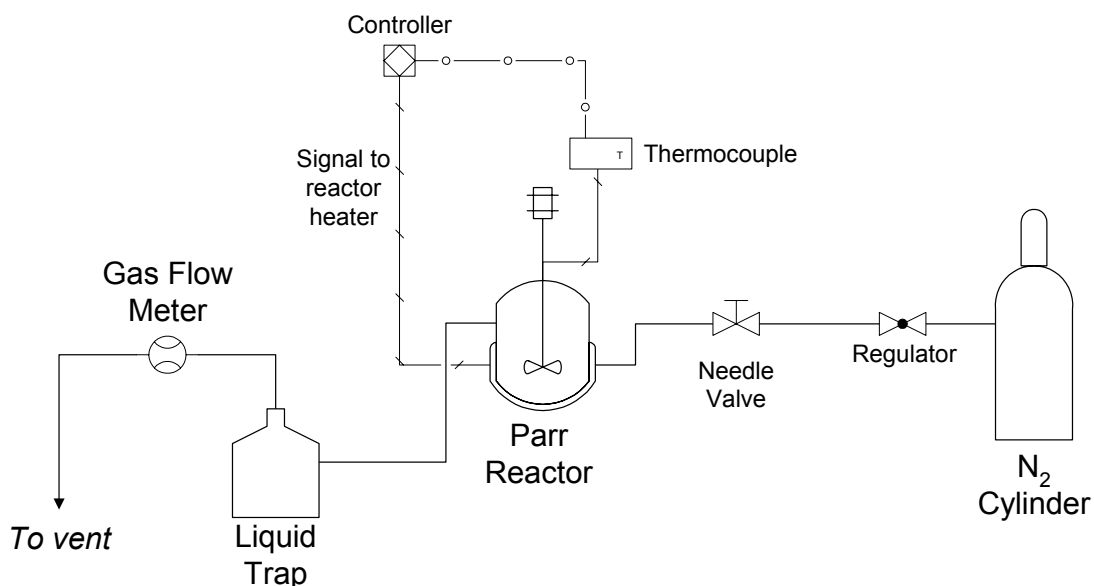

Figure 4. Process flow diagram for the laboratory-scale pyrolysis reactor system.



Figure 5. Parr reactor apparatus. The liquid product trap and gas flow meter are to the right of the reactor stand.

The procedure for pyrolysis tests in the Parr batch reactor was as follows:

- The polymer and catalyst powders were loaded into the reactor cylinder.
- The reactor was purged with N₂ at 30-40 sccm for ~60 minutes.
- The reactor temperature was raised to 110°C with continued N₂ flow. The reactor agitator was turned on at 50-60% power (300-360 rpm).
- The reactor temperature was maintained at 110°C for 75 minutes to purge moisture and O₂ from the powders. The N₂ purge gas flow rate was monitored during this degassing step to determine the baseline flow rate. The baseline N₂ rate was subtracted from the total gas flow rate during the pyrolysis run.
- The reactor temperature was increased to the desired pyrolysis temperature as rapidly as possible.
- When the temperature reached the final set point, the heat input to the reactor was automatically controlled to maintain the setting. In selected reaction tests, product gas samples were collected in 0.5-liter Tedlar bags downstream of the flow meter.
- The reactor heat was turned off when the pyrolysis gas production rate dropped to within a few percent of the baseline N₂ flow.
- The liquid products were recovered from the trap, and the solid residual and products were removed from the reactor cylinder.

The pyrolysis gas production was monitored throughout the experiments by recording the cumulative flow rate (as N₂) and correcting the flow using the estimated properties of the gas. In tests for which gas samples were collected and analyzed, the actual gas properties were used for the flow correction. The baseline N₂ flow rate measured during the 110°C purge step was subtracted from the flow measured during reaction. The gas production rate was used as a proxy indicator of the reaction rate, so a plot of instantaneous gas production versus time was assumed to be a valid representation of relative rate of reaction. The reaction test was stopped when the gas production declined to a negligible fraction above the baseline N₂ flow (typically ~1 sccm net pyrolysis gas).

2.3.1 Polypropylene Experimental Results

The effect of three process parameters on the pyrolysis rate and yield were investigated for polypropylene: temperature, catalyst loading, and pressure. Additionally, a full analysis of the pyrolysis products from a selected baseline process was conducted to determine if the pyrolysis liquids are compatible with conventional logistics fuels.

2.3.1.1 Temperature Effects

The temperature for the initial batch pyrolysis test with PP was 450°C, which was safely below the maximum temperature rating for the reactor but high enough for measurable conversion as demonstrated in the tubular reactor tests. It was hypothesized that better mixing of the feedstock and the catalyst in the Parr reactor would result in higher conversion at lower temperature than in the tubular reactor.

Two oil samples from the initial batch reaction tests were analyzed for heating value and C/H ratio. The results of the analyses are listed in Table 10. The pyrolysis gas production profile corresponding to the 350°C test in Table 10 is shown in Figure 6. The molecular formulas in Table 10 were calculated by assuming a mixture of aliphatics, aromatics, and naphthalenes in the range of C₈-C₁₂ and reconciling the calculated carbon-to-hydrogen ratio to the measured value by varying the fraction of the three compound types. The pyrolysis oil composition appears to be more aromatic than JP-8 as determined by the C-H and heat of combustion analyses. The lower heat of combustion for the PP-derived fuel compared to JP-8 (~5% less) may result in a slight de-rating of the electricity output of a conventional genset, but the PP-derived fuel should be completely miscible with the JP-8.

Table 10. Pyrolysis conversion and oil production from PP with ~9wt% HZSM-5 catalyst as a function of reactor temperature. [Heat of combustion and C-H analysis by Galbraith Labs]

Pyrolysis Temperature (°C)	PP Conversion (mass %)	Oil Yield (mass % of initial charge)	Net Heat of Combustion	Approximate Molecular Formula
325	97	30	--	--
350	100	35	17,523 Btu/lb (40.6 MJ/kg)	C _{9.4} H _{16.5}
450	100	39	17,820 Btu/lb (41.3 MJ/kg)	C _{9.6} H ₁₄

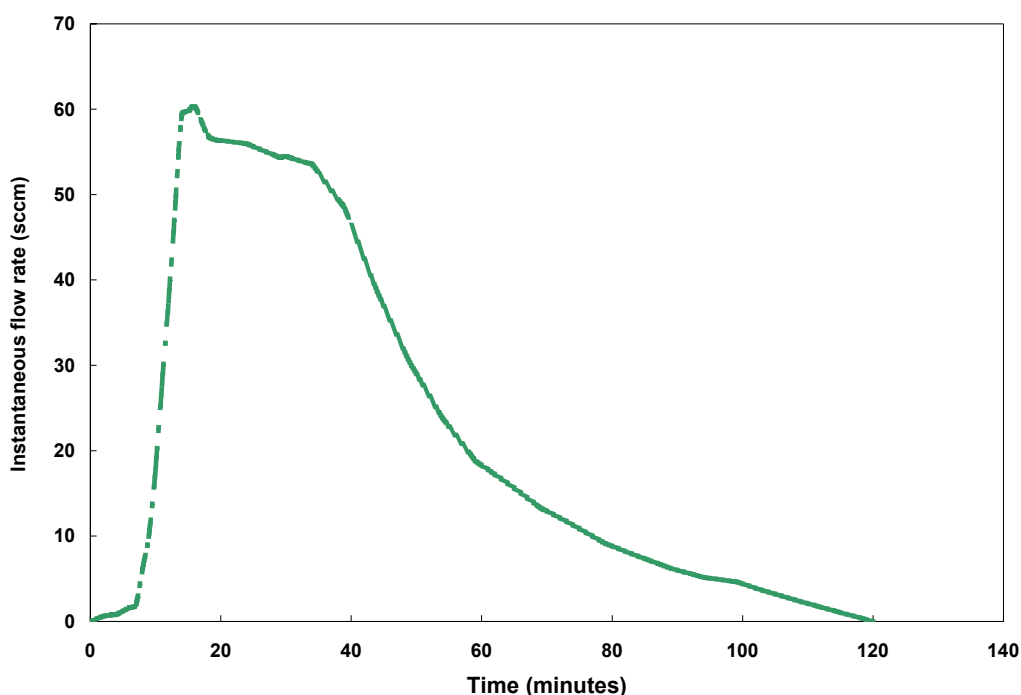

Figure 6. Polypropylene pyrolysis gas production at 350°C with ~9wt% HZSM-5 catalyst.

The slight increase in oil yield with increasing reactor temperature may be the result of thermal losses in the laboratory apparatus. The reaction cylinder attaches to the agitator fixture with a relatively large metal clamp, which may act effectively as a heat transfer ‘fin.’ The heat loss from the top of the reactor may cause the oil products that are still vapor at reactor temperatures to condense before they are carried out of the reactor zone to the liquid trap. Therefore, the heavy components (oils) were refluxed into the reaction zone where they further decomposed to a lighter fraction (gas). The N₂ purge stream helped to sweep some of these components from the reactor zone, but reduced thermal losses in a larger system should improve the oil-to-gas ratio compared to the laboratory results.

2.3.1.2 Pressure Effects

It was hypothesized that increasing the reactor pressure would result in increased oil yield in the product stream, since refinery catalytic cracking processes operate at slightly elevated pressures (15-30 psig).¹⁸ A PP pyrolysis test was conducted at 30 psig nominal pressure (31 psig actual) with 2.3wt% HZSM-5 catalyst at 350°C. The conversion and yield results for the elevated pressure test and the comparable 0 psig pressure tests are listed in Table 11.

The oil yield unexpectedly declined with increased pressure. The decline in yield with increased pressure may be related to the thermal losses and oil condensation effect that were discussed in Section 2.3.1.1 above. The higher pressure results in an increased boiling point for the liquid product components. The liquids are 'knocked back' into the reactor with greater ease than at ambient pressure and continue to crack to smaller chains that are finally able to escape the reactor zone and be captured in the trap.

Table 11. Pyrolysis conversion and oil production from PP at 350°C with 2.2wt% HZSM-5 catalyst as a function of reactor pressure.

Pressure	PP Conversion (mass %)	Oil Yield (mass % of PP initial charge)
0 psig	100	37 ± 1.4
31 psig	100	21

2.3.1.3 Catalyst Loading Effects

The standard reaction condition for the PP pyrolysis tests was selected as 350°C and atmospheric pressure based on the results of the temperature and pressure tests. A series of experiments were conducted with nominal 0, 1, 2, and 10 wt% catalyst loadings at the standard condition. The PP conversions and oil yields at the four catalyst loadings are listed in Table 12. The product yields for all three catalyst loadings were similar, with oil yields of 32-37 wt% and no clear trends. The necessity of using a catalyst is demonstrated by the poor conversion and oil yield in the no-catalyst test.

The gas production rates for the tests listed in Table 12 were compared to determine if there was a reaction rate advantage for higher catalyst loading, since there was negligible difference between the oil yields and conversions between the 2.2% and 9.3% tests. The gas production rates are compared in Figure 7. There is clearly a reduced rate of gas production for the 1.2% catalyst test, but the 2.2% and 9.3% tests are virtually indistinguishable. Therefore, a nominal catalyst loading of 2wt% was used for subsequent polypropylene and mixed plastic pyrolysis tests. (The target catalyst loading was 2wt%, but the actual mass used was typically ~2.5wt%).

¹⁸ Satterfield, C.N. *Heterogeneous Catalysis in Industrial Practice*, 2nd ed. McGraw-Hill, 1991, p. 354.

Table 12. Pyrolysis conversion and oil production from PP at 350°C as a function of HZSM-5 catalyst loading.

Catalyst Loading (mass % of initial charge)	PP Conversion (mass %)	Oil Yield (mass % of PP initial charge)
0	29	12
1.2	100	32
2.2 ± 0.3	100	37 ± 1.4
9.3 ± 0.1	100	35

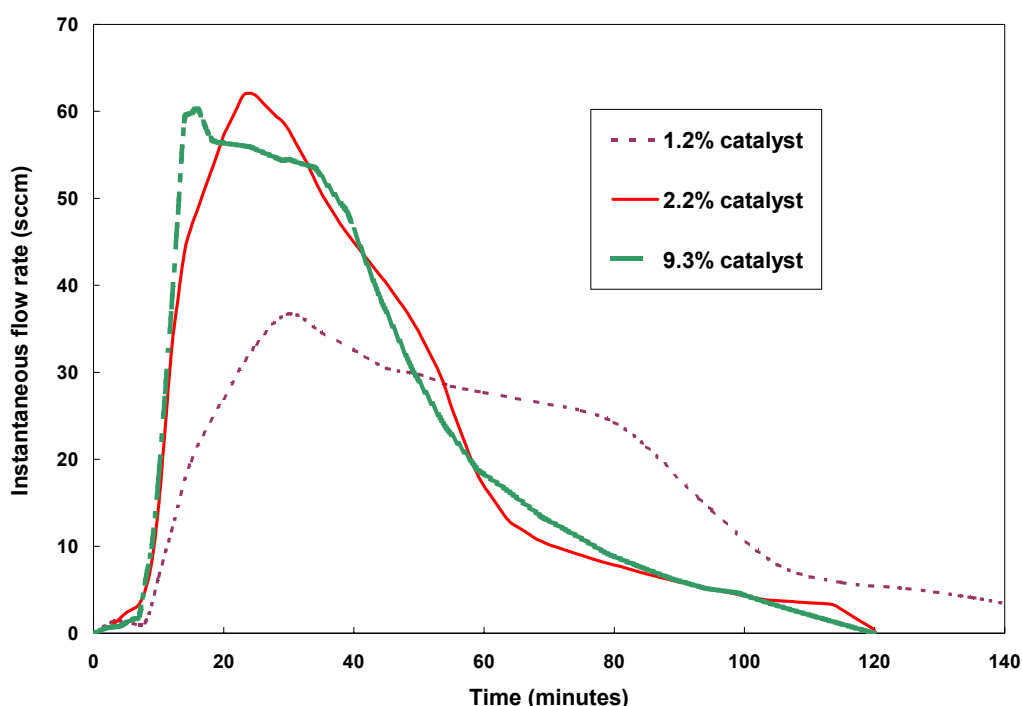

Figure 7. Gas production from pyrolysis of polypropylene at 350°C with varying levels of HZSM-5 catalyst. The 2.2% and 9.3% curves are composites of multiple runs.

Gas and liquid samples were collected from one of the 2wt% catalyst tests at 350°C and submitted to SPL, Inc. (Houston, TX) for full gas chromatographic (GC) analysis. Two ten-minute composite gas samples were collected in Tedlar® bags and analyzed using a standard refinery gas procedure (C₁-C₆₊ hydrocarbons plus fixed gases). Collection of the gas samples was initiated at 14 and 36 minutes after the start of the reaction test, that is, on both the positive and negative sides of the peak gas production shown as the red curve in Figure 7. The results of the gas analyses are listed in Table 13. There are only minor compositional differences between the two samples, indicating that the mechanism of PP decomposition does not change significantly during the period of highest reaction rate. The gas product properties are more similar to LPG or natural

gas liquids than to natural gas, which may have an effect on how the gas is recovered and stored in the process design.

The liquid product corresponding to the gas samples listed in Table 13 was submitted for a full PIANO¹⁹ analysis by GC. The PIANO analysis identified 227 peaks and grouped them by carbon number and hydrocarbon type. The carbon number distribution is shown in Figure 8 and fractions of each hydrocarbon type are listed in Table 14. Both the mass and volume fractions are included in Table 14 because the JP-8 specifications may list either fraction. The distribution of hydrocarbons present in the liquid, in conjunction with the API gravity of 42 and the research octane number (RON) of 93, places the liquid in the gasoline range. In fact, the RON of 93 would result in a gasoline antiknock index²⁰ indistinguishable from commercial gasoline sold at any corner station. As a result, the polypropylene-derived liquid may not be compatible with the military compression-ignition generators since gasoline combustion generally requires spark ignition. However, if the fraction of waste-derived fuel is small relative to the total fuel supply, then the waste-derived fuel could be blended with the JP-8 without significantly impairing engine function.

Table 13. Refinery gas analysis of PP pyrolysis with HZSM-5 catalyst gas samples (10-minute composite samples). [analysis by SPL, Inc.]

Mass %	Sample 1	Sample 2	Average
C ₄ alkanes	22.6	23.2	22.9
C ₆₊	20.7	19.0	19.9
C ₄ alkenes	18.9	19.9	19.4
C ₅ alkanes	13.8	13.4	13.6
C ₃ H ₆	11.2	12.2	11.7
C ₃ H ₈	10.4	10.1	10.2
C ₂ H ₄	1.8	2.0	1.9
C ₂ H ₆	0.4	0.2	0.3
Others	0.2	0.1	0.2
Molecular weight	57.0	56.7	56.8
Average molecular formula	C ₄ H ₉	C ₄ H ₉	C ₄ H ₉
Lower heating value	19,813 Btu/lb (45.9 MJ/kg)	19,789 Btu/lb (45.9 MJ/kg)	19,801 Btu/lb (45.9 MJ/kg)

¹⁹ P=paraffin, I=iso-paraffin, A=aromatic, N=naphthene, O=olefin.

²⁰ The anti-knock index, or "octane number," reported at civilian gas stations is an average of the RON and the motor octane number (MON).

Table 14. Hydrocarbon types present in pyrolysis liquid product from polypropylene feedstock at 350°C with HZSM-5 catalyst. [analysis by SPL, Inc.]

Hydrocarbon Type	Mass %	Volume %
Paraffins	11.5	12.2
Isoparaffins	17.8	19.5
Aromatics	35.3	31.6
Naphthenics	18.7	18.6
Olefins	15.8	17.1
Unknowns	1.0	1.0
Average molecular formula	$C_8H_{14.4}$	
Specific gravity @ 16°C	0.81 g/cm ³	
Research octane number	93	
Calculated lower heating value	18,647 Btu/lb (43.2 MJ/kg)	

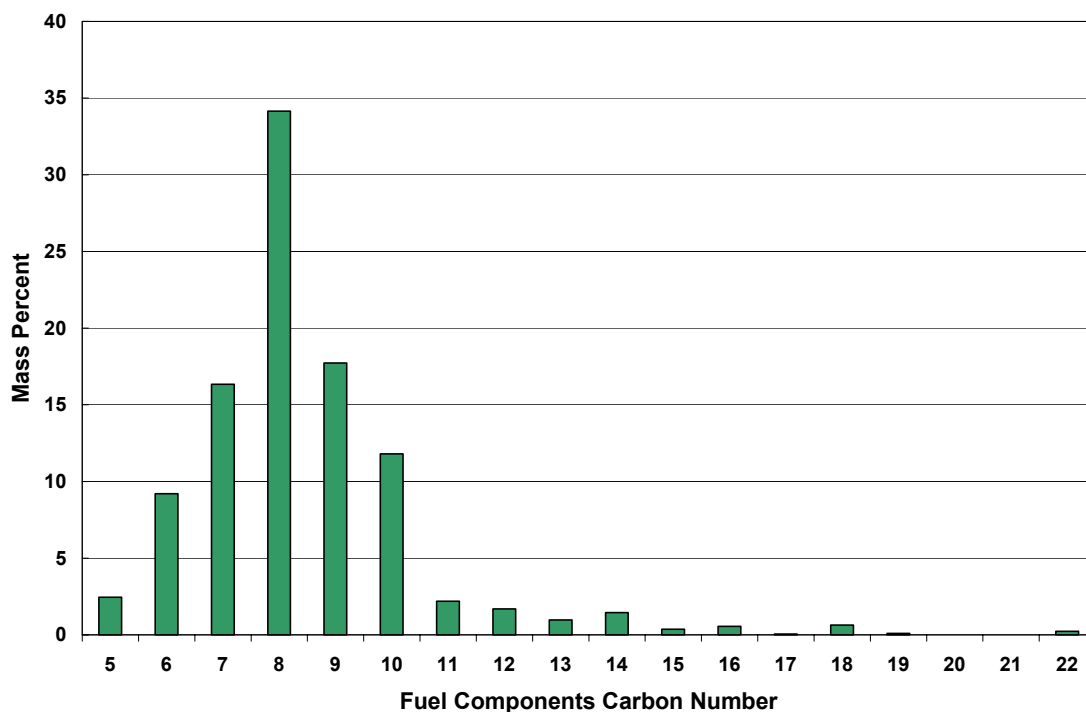

Figure 8. Distribution of products by carbon number in the pyrolysis liquid product from polypropylene feedstock with HZSM-5 catalyst. [analysis by SPL, Inc.]

2.3.2 Mixed Plastic Experimental Results

The baseline catalyst loading of ~2wt% determined from the polypropylene pyrolysis tests was adopted for the mixed plastic tests. The initial mixed plastic experiments focused on the effect of reaction temperature on the pyrolysis rate and yield. The gas production rates from the initial 350°C and 400°C tests are shown in Figure 9, and the conversion and oil yield results are listed in Table 15.

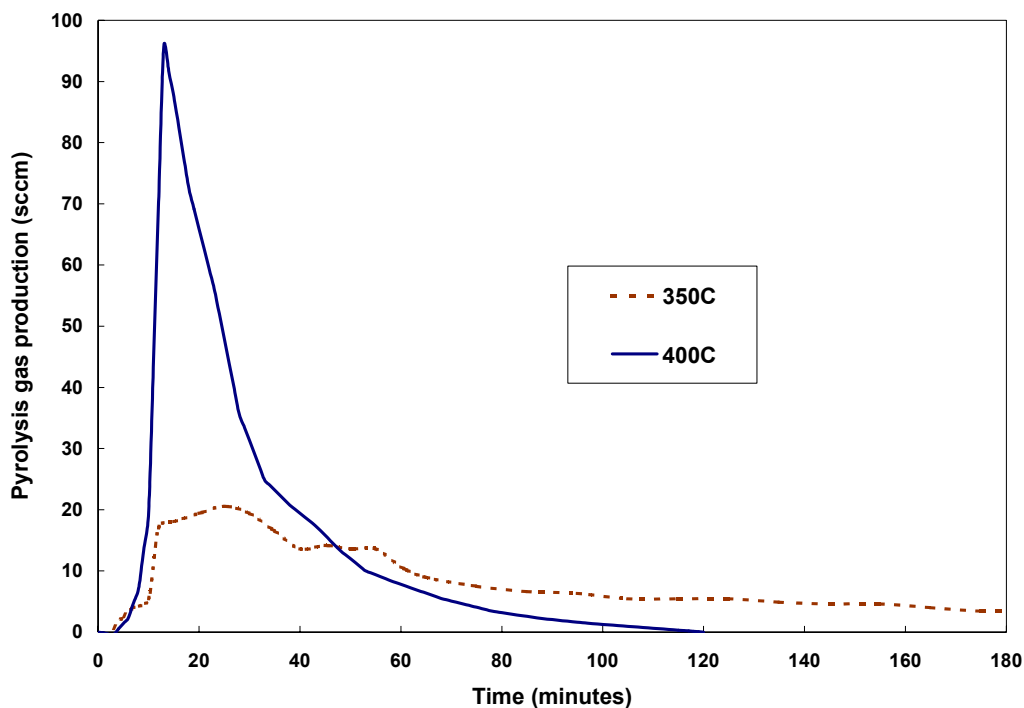

Figure 9. Mixed plastic pyrolysis gas production with 2.4±0.1 wt% HZSM-5 catalyst as a function of reactor temperature.

There is clearly an increased rate of pyrolysis, polymer conversion, and oil yield at 400°C compared to 350°C. Based on the results of the temperature screening, a temperature of 400°C, atmospheric pressure, and 2-2.5wt% HZSM-5 were chosen as the baseline conditions for the mixed plastic pyrolysis.

Table 15. Pyrolysis conversion and oil production from mixed plastic with 2.4±0.1 wt% HZSM-5 catalyst as a function of reactor temperature.

Pyrolysis Temperature (°C)	Total Polymer Conversion (mass %)	Oil Yield (mass % of initial charge)
350	97	43
400	100	48

Multiple tests were conducted at the baseline mixed plastic conditions to determine the process variability and to fully characterize the reaction products. The average gas production profile at the baseline conditions is shown in Figure 10. Typically the gas evolution was >90% complete after 60 minutes and >98% complete after 90 minutes. The reaction times included the time to heat the reactor from the 110°C degassing condition to the reaction temperature, approximately 10-15 minutes in most cases. The polymer conversion was 100% in all tests, and the average oil yield was $49 \pm 1\%$.

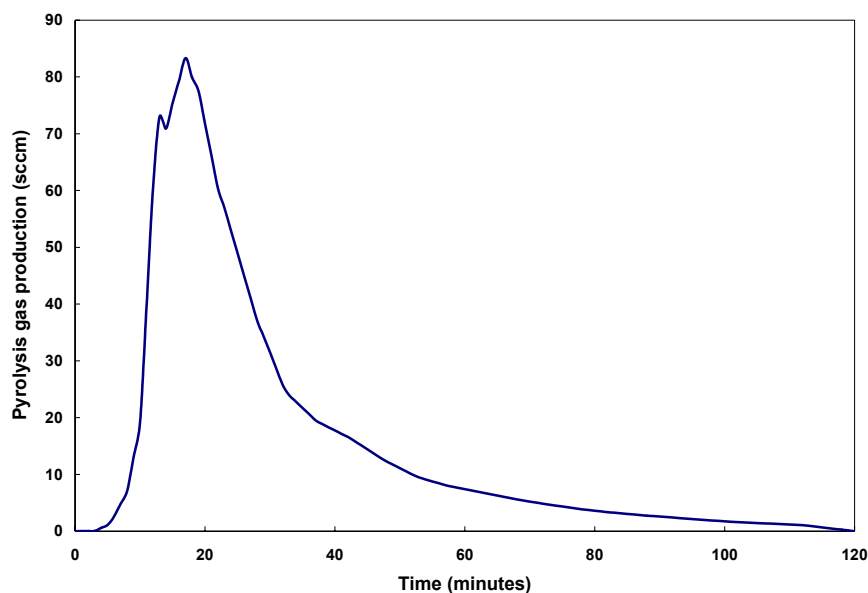

Figure 10. Average gas production from pyrolysis of mixed plastic waste at 400°C with 2.3wt% HZSM-5 catalyst.

The gas and liquid products from two tests at the baseline conditions were analyzed by GC to identify and quantify the product species. The gas product composition and properties are listed in Table 16. The gas composition is similar to a butane or liquefied petroleum gas (LPG) that is a gas at ambient conditions but condenses at relatively mild elevated pressures. The gas characteristics allow for the possibility of storing the compressed “LPG.” Storage of the gas product will be considered in the process design.

The distribution of liquid products by carbon number is shown in Figure 11 and in Table 17 by compound type along with the fuel properties is shown. The distributions are an average of the GC analyses of two samples collected from pyrolysis at 400°C with fresh HZSM-5 catalyst. The GC analysis quantified ~200 distinct compounds by using PIANO groupings. Of the 200 peaks, approximately 45 were identified only by the PIANO designation and the rest were identified by common name.

Table 16. Refinery gas analysis of mixed plastic pyrolysis with HZSM-5 catalyst gas product (12-minute composite sample). [analysis by SPL]

Component	Mass %
C ₄ alkenes	31.0
C ₃ H ₆	23.4
C ₆₊	13.8
C ₄ alkenes	11.0
C ₅ alkanes	8.3
C ₃ H ₈	8.1
C ₂ H ₄	3.2
C ₂ H ₆	0.9
Others	0.4
Molecular weight	52
Average molecular formula	C _{3.6} H ₈
Lower heating value	19,742 Btu/lb (45.8 MJ/kg)

The carbon number distribution skews lower than the midpoint of the JP-8 product distribution (~C₁₁). As a result, the initial boiling point of the waste-derived samples may be lower than the initial boiling point range of JP-8. The lower boiling point for the waste-derived fuel may lead to increased vaporization losses during storage at high ambient temperatures, although if the fuel is used soon after production, the losses should be minimal. The standard refinery fuel boiling point range measurements require a large quantity of liquid (>50g), far more than was generated during the laboratory experiments, particularly when some sample was required for the higher-priority composition analyses. The aromatic and olefin contents of the waste-derived fuel listed in Table 16 slightly exceed the fuel specification ranges—25 volume% for aromatics and 5 volume% for olefins. The elevated aromatic content leads to increased volumetric heating value and decreased mass heating value. In summary, the composition and properties of the mixed waste-derived fuel (WDF) from HZSM-5 catalyst are compatible with JP-8, although the WDF does not strictly meet JP-8 specifications. Thus, there is an opportunity to adjust the WDF composition by choice of catalyst and/or process conditions.

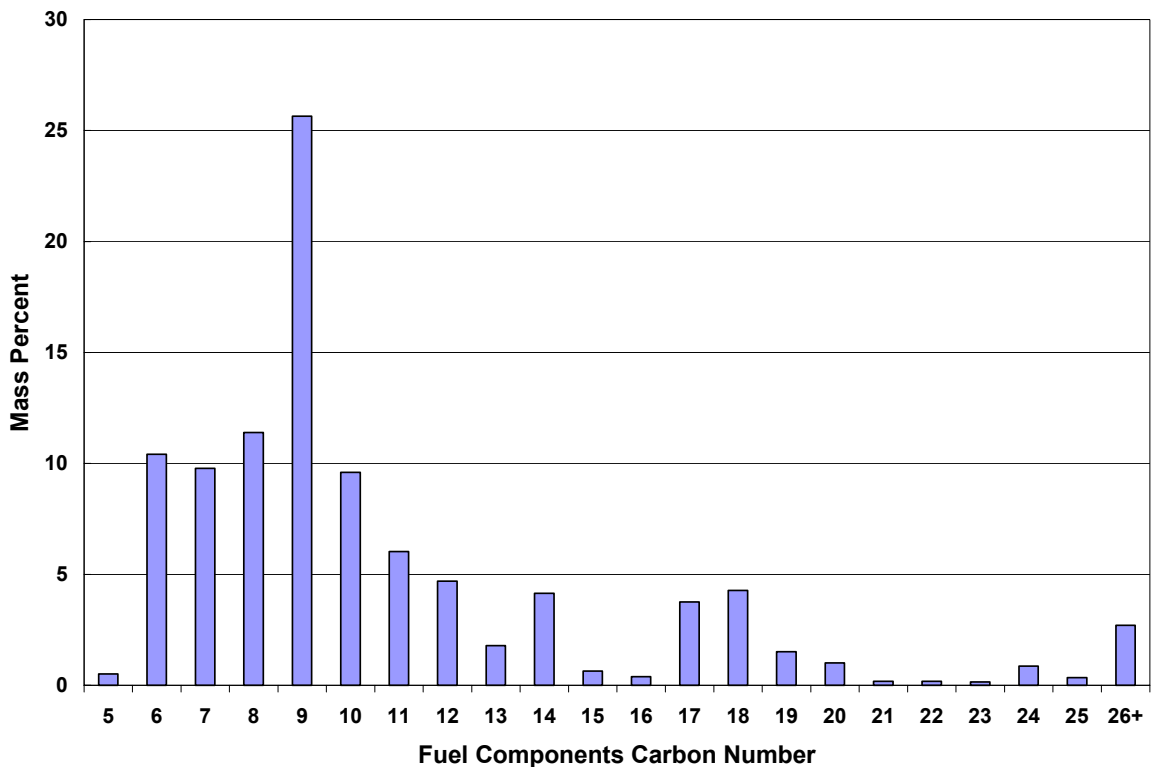

Figure 11. Distribution of products by carbon number in the pyrolysis liquid product from mixed plastic feedstock with HZSM-5 catalyst. [average of two analyses by SPL, Inc.]

Table 17. Hydrocarbon types present in and properties of pyrolysis liquid product from mixed plastic feedstock with HZSM-5 catalyst. [average of two analyses by SPL, Inc.]

Hydrocarbon Type	Mass %	Volume %
Paraffins	23.8	24.4
Isoparaffins	22.3	24.1
Aromatics	31.1	27.8
Naphthenics	12.5	12.7
Olefins	7.4	8.2
Unknowns/C ₂₆₊	2.9	2.9
Average molecular formula	C _{9.3} H ₁₇	
Specific gravity @ 16°C	0.76 g/cm ³ (calculated)	
Research octane number	86	
Calculated lower heating value	18,657 Btu/lb (43.3 MJ/kg)	

The replacement or regeneration of the catalyst could create an additional logistics burden in field operation of the waste-to-fuel conversion process. To judge the effect of repeated batches with the same catalyst, three mixed plastic pyrolysis tests were conducted without adding additional catalyst or cleaning the reactor cylinder between runs. The pyrolysis gas production rates for the catalyst repeated-use test are shown in Figure 12. The gas flow meter experienced an outage near the beginning of the first run, so only the second and third runs have complete data. The composite curve from Figure 10 has been substituted for the first run since it is at the same process conditions and should have a similar profile.

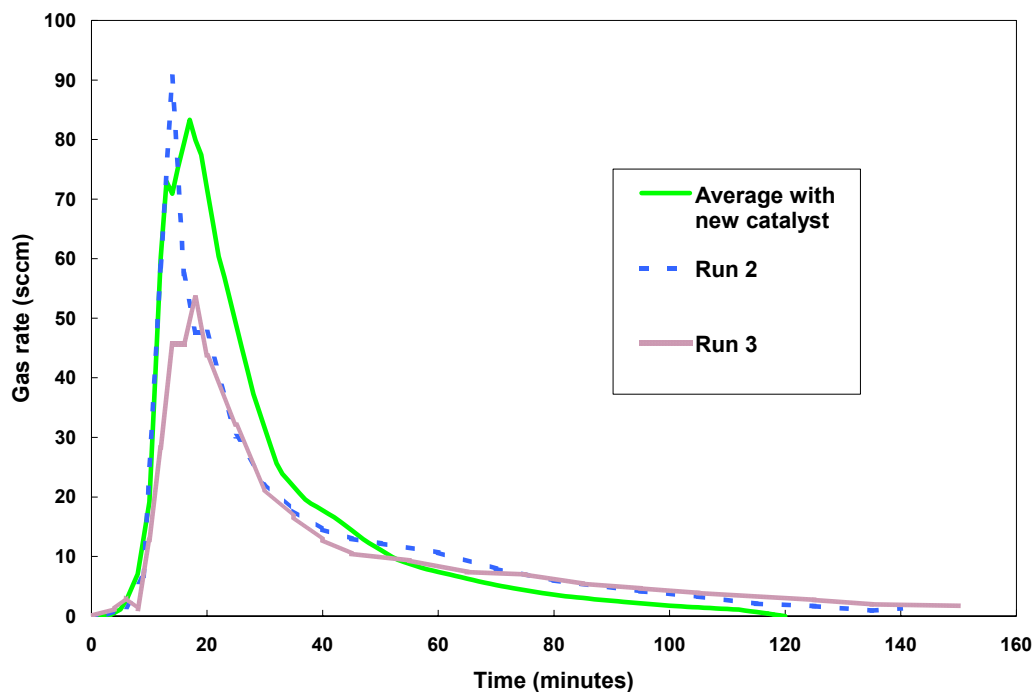

Figure 12. Pyrolysis gas production rate at 400°C with 2.5wt% HZSM-5 catalyst and repeat use of the same catalyst for three consecutive tests.

The distributions of components by carbon number from the first two runs of the catalyst repeated-use test are compared in Figure 13. The third sample was analyzed only for heat of combustion, so the composition of the third point in the trend is not available.²¹ The aromatic content of the product from the second run was dramatically reduced from the level in the first run, with a corresponding increase in naphthenic content. The increase in concentration of the most prevalent component in both runs --1,2,4-trimethylcyclohexane -- from the first run to the second run was 8.3wt% to 30.9wt%. The increased trimethylcyclohexane yield accounts for the shift from aromatics to naphthenics in Table 18 and the increased C₉ peak height in Figure 13. Benzene, toluene, and xylenes combined showed a corresponding decrease in abundance.

²¹ The sample sizes generally were sufficient for only one type of analysis, and the heat of combustion had not been measured for any of the other 400°C mixed plastic tests.

Table 18. Oil yields, compositions, and properties for mixed plastic waste pyrolysis at 400°C with 2.5wt% HZSM-5 catalyst, repeat use of the same catalyst with no regeneration. [analysis by SPL]

	Test		
	1	2	3
Oil yield (mass %)	50	54	59
PIANO Analysis Results (mass %)			
Paraffin	21.8	23.6	--
Isoparaffins	18.1	12.8	--
Aromatics	29.3	11.9	--
Naphthenes	20.5	39.7	--
Olefins	7.6	7.7	--
Unknowns/C ₂₆₊	2.6	4.3	--
Fuel Properties			
Average molecular formula	C _{9.3} H _{16.9}	C _{9.8} H _{19.2}	--
Specific gravity @ 16°C	0.77	0.78	--
Research octane number	91	86	--
Net heat of combustion (calculated)	18,647 Btu/lb (43.2 MJ/kg)	18,826 Btu/lb (43.7 MJ/kg)	--
Gross heat of combustion (measured)	--	--	18,945 Btu/lb (43.9 MJ/kg)

HZSM-5 catalyst was used for the polymer pyrolysis experiments described to this point. Late in the project, a reference was found to the tendency of the hydrogen form of the zeolite mordenite to yield jet fuel-range liquids from polymer pyrolysis, as compared to the tendency of HZSM-5 to yield gasoline-range liquids.²² The standard mixed plastic pyrolysis test (400°C, 2.5wt% catalyst) was conducted with the mordenite catalyst in place of the HZSM-5. The pyrolysis gas evolution for the mordenite catalyst is shown in comparison to the HZSM-5 catalyst in Figure 14.

²² Uçar, S., *et al.* "Conversion of polymers to fuels in a refinery stream." *Polymer Degradation and Stability* **75** (2002) 161-171.

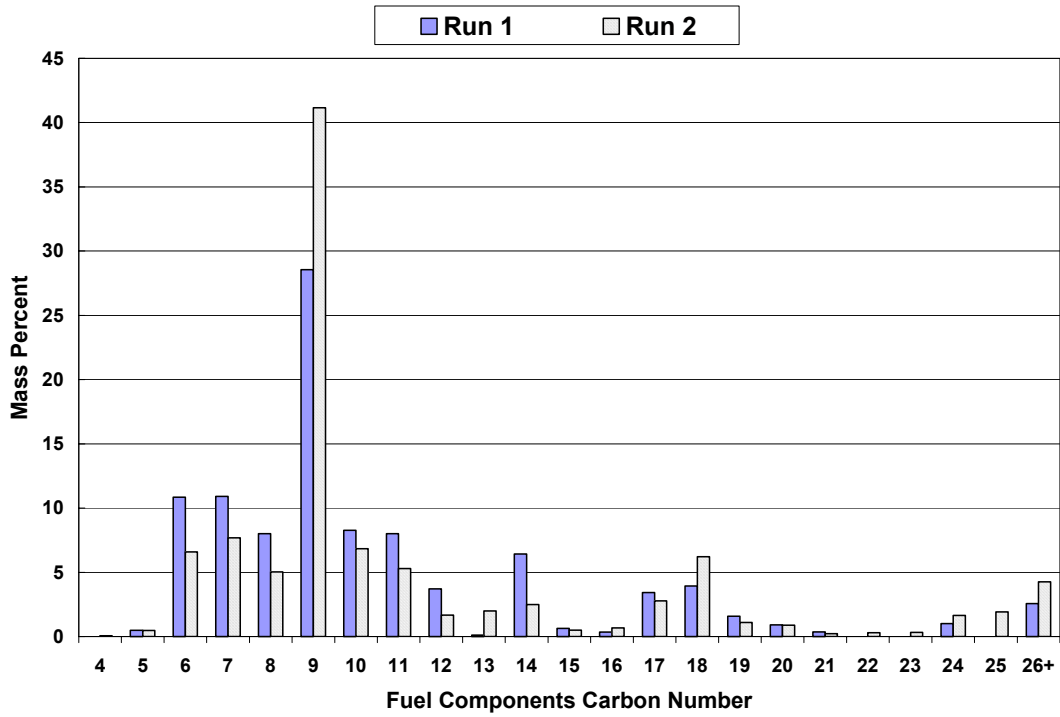

Figure 13. Distribution of products by carbon number in the pyrolysis liquid product from mixed plastic feedstock with repeated use of HZSM-5 catalyst. [analysis by SPL, Inc.]

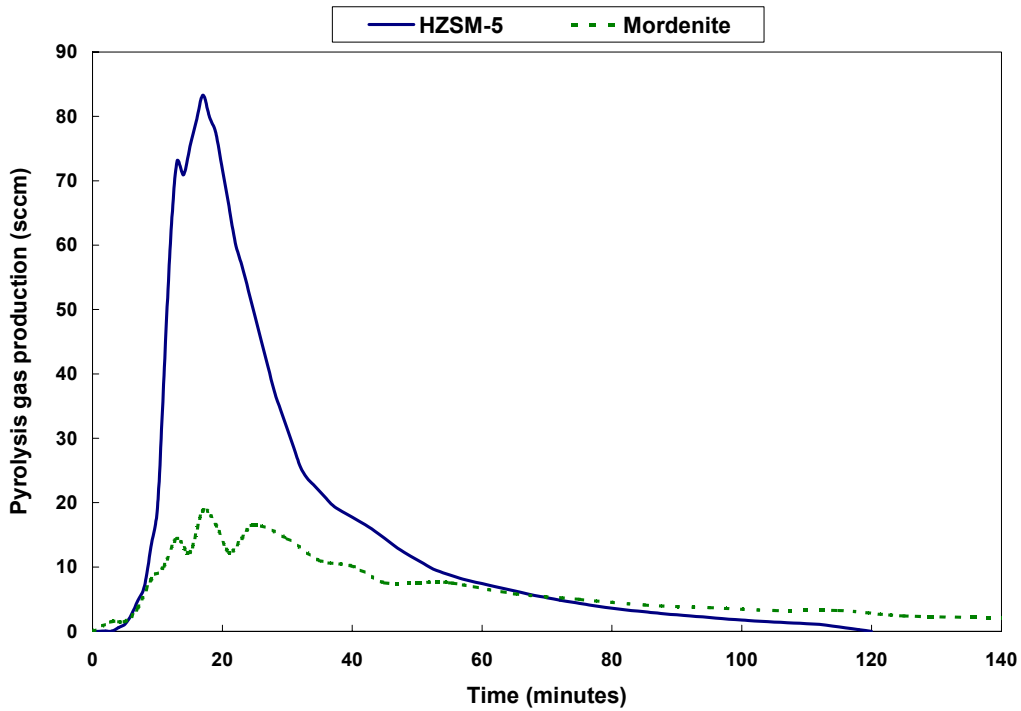

Figure 14. Pyrolysis gas production from mixed plastic feedstock with mordenite (dashed green line) and HZSM-5 (solid blue line).

The reduced gas production with mordenite compared to HZSM-5 was validated by a corresponding increase in the oil yield. The oil yield for the mordenite catalyst was 65wt%, compared with an average oil yield of 49wt% for the HZSM-5 catalyst. The gas composition with mordenite (Table 19) was shifted to higher molecular weight than the gas produced with HZSM-5, with the average gas molecular formula of $C_4H_{9.2}$ vs. $C_{3.6}H_8$. The butane-equivalent composition of the gas will allow recovery and storage of the gas if desired, since the vapor can be liquefied at ambient temperature and ~40-50psig. The oil compositions and carbon number distributions from the mordenite and HZSM-5 experiments are shown in Table 20 and Figure 15, respectively.

Table 19. Refinery gas analysis of pyrolysis gas product at 400°C with mordenite catalyst (15-minute composite sample). [analysis by SPL]

Component	Mass %
C ₆₊	37.1
C ₄ alkenes	21.0
C ₅ alkanes	15.2
C ₃ H ₆	13.6
C ₃ H ₈	5.2
C ₄ alkanes	3.0
C ₂ H ₆	2.4
C ₂ H ₄	0.9
Others	1.7
Molecular weight	58
Average molecular formula	C ₄ H _{9.2}
Lower heating value	20,021Btu/lb (46.4 MJ/kg)

The mordenite catalyst experiment was repeated at 425°C to test the effect of temperature on fuel composition and gas and oil yields. Only the liquid fuel product was analyzed from the 425°C test. The results of the 425°C mordenite run are compared with the 400°C mordenite results in Table 21 and Figure 16. The only significant difference between the 400°C and 425°C results is a shift to more paraffin (by mass) and less isoparaffin at the higher temperature. There is also a slight shift to heavier molecular weights at 425°C compared to 400°C, possibly due to the “reflux” effect in the Parr reactor described in Section 2.3.1.1. The average oil yield improved to 73% at 425°C compared to 65% at 400°C. The mordenite catalyst resulted in a relatively high degree of selectivity for a few components, given that there were >200 peaks identified in the gas chromatograph scans. The single component 3-methyloctane accounted for 30.4wt% at 400°C and 25.8wt% at 425°C. The structurally similar molecule 2-methylnonane was present at 3.6wt% in both cases (4th most abundant at 400°C and 3rd at 425°C).

Table 20. Hydrocarbon types in and properties of pyrolysis liquid product from mixed plastic with mordenite catalyst at 400°C, with HZSM-5 results included for comparison. [analysis by SPL, Inc.]

Hydrocarbon Type	Mordenite		HZSM-5	
	Mass %	Volume %	Mass %	Volume %
Paraffins	23.6	23.0	23.8	24.4
Isoparaffins	46.5	48.4	22.3	24.1
Aromatics	8.9	7.6	31.1	27.8
Naphthenics	9.1	8.8	12.5	12.7
Olefins	8.4	8.8	7.4	8.2
Unknowns/C ₂₆₊	3.6	3.4	2.9	2.9
Average molecular formula				
	C _{9.8} H ₂₀		C _{9.3} H ₁₇	
Specific gravity @ 16°C	0.84 g/cm ³ (measured)		0.76 g/cm ³ (calculated)	
Research octane number	59		86	
Calculated lower heating value	18,992 Btu/lb (44.0 MJ/kg)		18,657 Btu/lb (43.3 MJ/kg)	

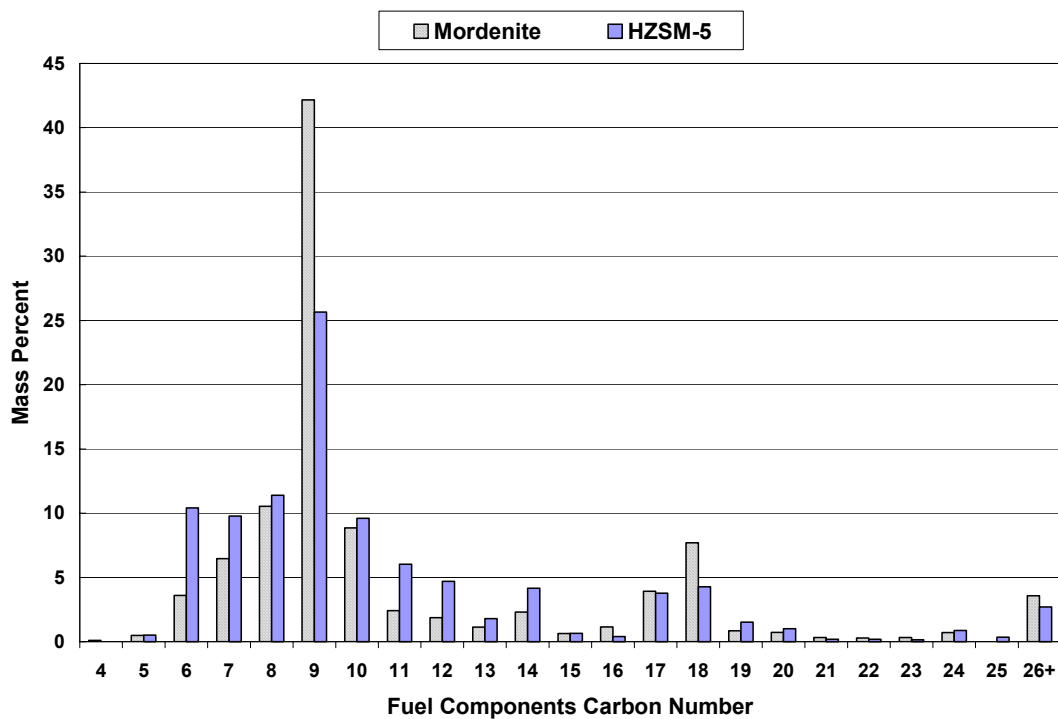

Figure 15. Distribution of products by carbon number in the pyrolysis liquid product from mixed plastic feedstock with mordenite and HZSM-5 catalysts. [analysis by SPL, Inc.]

Table 21. Hydrocarbon types present in and properties of pyrolysis liquid product from mixed plastic feedstock with mordenite catalyst at 425°C and 400°C. [analysis by SPL, Inc.]

Hydrocarbon Type	Mordenite, 425°C		Mordenite, 400°C	
	Mass %	Volume %	Mass %	Volume %
Paraffins	29.4	19.2	23.6	23.0
Isoparaffins	39.4	42.9	46.5	48.4
Aromatics	10.3	13.5	8.9	7.6
Naphthenics	9.2	11.1	9.1	8.8
Olefins	7.9	11.9	8.4	8.8
Unknowns/C ₂₆₊	3.7	1.5	3.6	3.4
Average molecular formula	C _{10.0} H _{20.6}		C _{9.8} H ₂₀	
Specific gravity @ 16°C	0.84 g/cm ³ (measured)		0.84 g/cm ³ (measured)	
Calculated lower heating value	18,978 Btu/lb (44.0 MJ/kg)		18,992 Btu/lb (44.0 MJ/kg)	

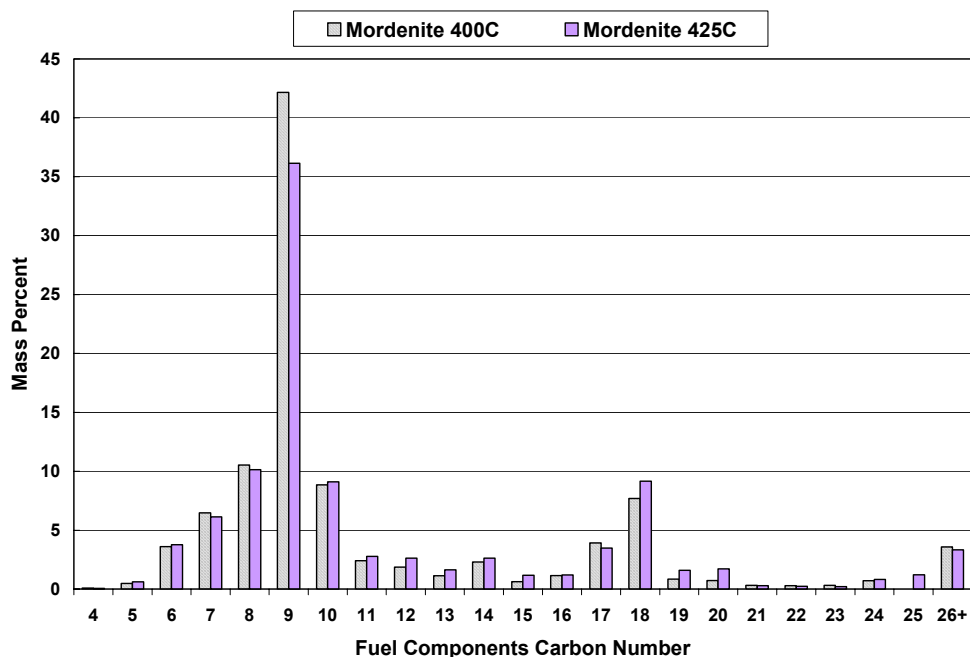

Figure 16. Distribution of products by carbon number in the pyrolysis liquid product from mixed plastic feedstock with mordenite catalyst at 425°C and 400°C. [analysis by SPL, Inc.]

2.3.3 Cellulose Fluff and Polyhydroxybutyrate Experimental Results

The cellulose fluff used in the initial pyrolysis screening experiments was tested in the batch reactor apparatus for a direct comparison to the plastic pyrolysis. The experimental procedure was identical to the mixed plastic procedure at 400°C. A high catalyst loading of 9wt% was used to generate as high a reaction rate as possible. The gas production from the cellulose fluff experiment is compared with the average gas production from the mixed plastic in Figure 17. There was a small spike in gas flow rate at the beginning of the run, but the gas production was barely above the baseline nitrogen flow for the duration of the experiment.

The product breakdown and conversion from the fluff pyrolysis after 100 minutes at 400°C are listed in Table 22. Interestingly, approximately half of the char remaining in the reactor after the experiment appeared visually to be unchanged from its original state. Clearly, the pyrolysis temperature for the cellulose fluff must be significantly higher than 400°C to achieve high conversion. The maximum safe temperature for the batch pyrolysis apparatus was 425-450°C, so no additional experiments were conducted to convert the cellulose fluff.

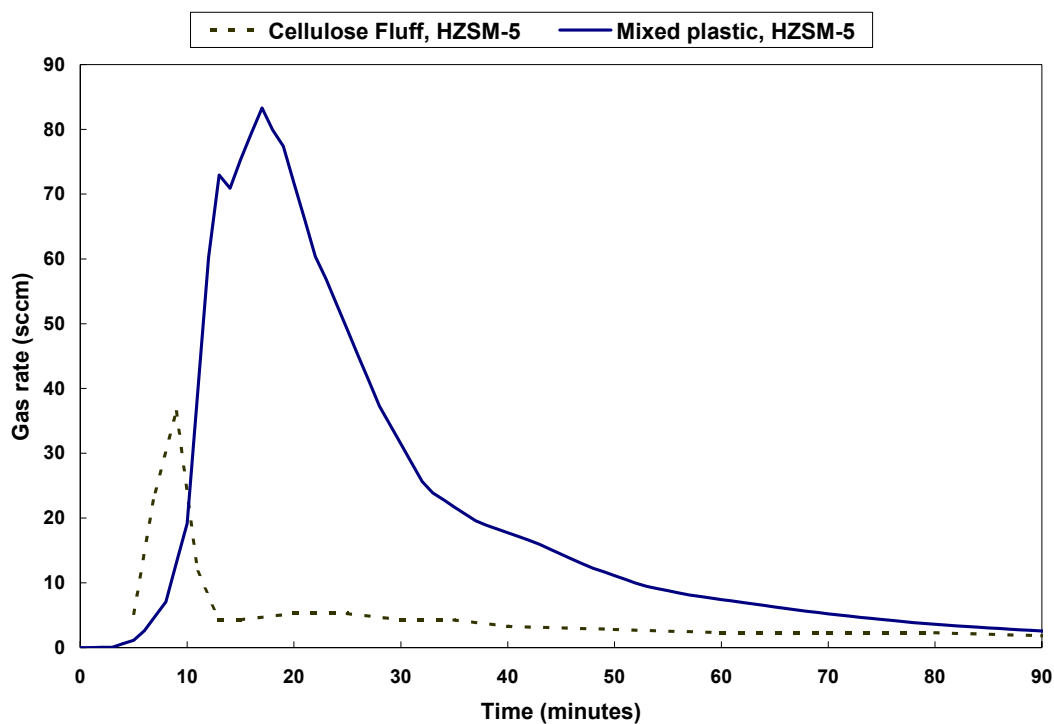

Figure 17. Pyrolysis gas production with HZSM-5 catalyst at 400°C from cellulose fluff (dashed olive line) and mixed plastic feedstock (solid blue line). The catalyst levels were 9wt% for the cellulose fluff and 2.5wt% for the mixed plastic.

Table 22. Pyrolysis conversion and oil production from cellulose fluff at 400°C with 9 wt% HZSM-5 catalyst.

Basis	Total Fluff Conversion (mass %)	Oil Yield (mass % of initial charge)
Wet basis (as received)	58	14
Dry basis	47	18

The biopolymer PHB was heated without catalyst in the pyrolysis reactor to determine the thermal decomposition limit. The polymer pellets were degassed at 80°C with flowing nitrogen instead of the usual 110°C since the manufacturer’s reported maximum working temperature is 95°C. The reactor was heated in 20°C increments with a 15 minute hold at each temperature step. An uncontrolled decomposition occurred at a temperature of ~250°C with complete conversion of the polymer to gas but no recoverable liquid product. The gas had an acrid odor, which is to be expected from the decomposition of an acid group-containing polymer. Because of the potential hazard of the PHB decomposition products and low probability for generating liquid fuels, no additional experiments were conducted with the PHB.

2.4 Pyrolysis Summary and Discussion

Tubular reactor experiments were used to screen cellulose and plastic feedstocks to narrow the range of process conditions. The poor yields and product quality for cellulose fluff compared to polypropylene led to a decision to focus on plastics conversion to produce liquid hydrocarbon fuels. The waxy solid product formed from the cellulose fluff pyrolysis had a coal-like energy content and could be used as a fuel in any process that accepts solid feedstocks. However, the relatively high nitrogen and sulfur contents of the cellulose fluff could cause corrosion problems in conventional equipment, cause instability in a stored fuel, or lead to poisoning of fuel cells (if the pyrolysis products are used to power future military fuel cells). Conversely, the tubular reactor experiments with polypropylene indicated that reasonable conversion rates and high-energy content fuels were achievable with commercial HZSM-5 catalyst. The tubular reactor was limited in that the polymer powders and catalyst were not well mixed and the isothermal zone was relatively small.

A Parr batch reactor was used to provide a well-mixed, isothermal condition for the polymer pyrolysis. The goal of the batch pyrolysis was to achieve the highest oil product yield possible, since the conceptual design of the full-scale process (see Section 3) was linked to a fuel production rate that would provide a given electricity production. Initial experiments were conducted using a pure polypropylene feedstock to identify the important process variables, including temperature, HZSM-5 catalyst loading, and pressure. It was determined that there was only a small gain in yield by increasing the temperature above 350°C or the catalyst loading above 2wt%. The oil yield decreased with increasing pressure, since only lower molecular weight products could “escape” the reactor at a given temperature.

The chosen process conditions for polypropylene pyrolysis—350°C, 2wt% HZSM-5, and atmospheric pressure—were explored in more detail. The ultimate goal of this project was to design a process for converting a *mixed* plastic waste to liquid fuels. However, the polypropylene pyrolysis was convenient for initial experiments since it was available in bulk quantities (i.e., inexpensive) and the single feedstock component potentially allowed for a mechanistic understanding of the pyrolysis reactions. As reported in the literature (see Ref. 22), use of the HZSM-5 catalyst resulted in the production of gasoline-range hydrocarbon liquids. In fact, with the polypropylene feedstock, the liquid pyrolysis product had a research octane number (RON) of 93. The corresponding “(R+M)/2” octane number reported at gasoline stations would likely be in the range 85-90, or the equivalent of standard unleaded gasoline.²³ The molecular weight and boiling point of the polypropylene-derived fuel may be slightly higher than is typical for gasoline. Overall, with some improvement in the liquid yield, the pyrolysis of polypropylene using commercial HZSM-5 catalyst is a promising method for producing gasoline-type fuels.

The pyrolysis of mixed plastic wastes shows promise for the production of kerosene-range hydrocarbon fuels at high yields (>70wt%) that would be compatible with conventional JP-8. The liquids produced using mordenite catalyst have properties that are very similar to JP-8 specifications, with two exceptions: slightly low molecular weight and high olefin content.

- The average molecular formula of the laboratory waste derived fuel (WDF) was $\sim\text{C}_{10}\text{H}_{21}$, compared to the typical JP-8 formula of $\sim\text{C}_{11}\text{H}_{22}$. The reduced molecular weight in the WDF may lead to increased vapor pressure and potential safety and handling concerns. However, there is significant room for optimization of the process conditions and catalyst properties to deliver the desired molecular weight distribution in the WDF. For example, the heat losses that caused the reflux effect in the laboratory-scale reactor can be better controlled in the full-scale apparatus.²⁴ The heat losses can be controlled to advantage in the full-scale design so that the range of hydrocarbon chain lengths in the fuel can be selected.
- The olefin content of the mordenite WDF ranged from 9-12vol%, compared to a JP-8 specification of 5vol% maximum. In a refinery or stationary recycling facility, hydrogen gas could be co-fed to the pyrolysis reactor to reduce the olefin (and aromatic) content of the fuel. The field converter will not have the option of supplying hydrogen to the reactor. However, the mordenite WDF has an aromatic content, 7.6-13.5vol%, that is significantly below the JP-8 maximum specification of 25vol%. Assuming that the elevated olefins do not adversely affect the fuel stability during storage, the performance of the WDF in the generator engine should not be harmed.

²³ Only the RON was reported from the PIANO analysis of the liquid samples, however, the differences between RON and (R+M)/2 ratings assumed here are typical. The difference between RON and MON can vary significantly depending on the actual composition of the fuel.

²⁴ There will be a significant reduction in the external surface area per volume of reactor compared to the lab-scale equipment, therefore, greatly reducing the conduction heat loss to the atmosphere.

The repeated use of the HZSM-5 catalyst for mixed plastic demonstrated that there is not significant deactivation with up to three batches with the same catalyst. In fact, the oil yield and the selectivity to naphthenes and away from aromatics (a good thing for kerosene-type fuels) improved with subsequent uses of the catalyst. The effects of long-term use of the catalysts on pyrolysis oil properties would be an important topic for additional study. The logistics burden for supplying catalyst would be much reduced if the catalyst were replaced only once per day instead of after every batch.

The calculated heating values are higher than the measured heating values because the components heavier than C₁₃ are lumped by carbon number and assumed to have the heating values of the corresponding alkanes. This means that we are assuming an alkane heating value for some number of aromatic, olefin, or naphthenic components, all of which have a lower heat of combustion than alkanes.

The highest oil yield from mixed plastic waste, and therefore the best conversion efficiency to liquid fuels, was with the mordenite catalyst at 425°C. The liquid product appears to be chemically compatible with JP-8, although the fuel quality is examined in more detail in Section 2.5. The pyrolysis gas at these conditions contains a high mass fraction of C₄-C₆ hydrocarbons.²⁵ The vapor pressure for the gas composition listed in Table 19 is 38 psig (361 kPa absolute) at 20°C, which will allow for simple compression and storage of the gas in a vessel like a commercial propane cylinder. Consequently, we used the process conditions, yields, and fluid properties from the mixed plastic mordenite test at 425°C as the basis for the process design in Section 3.

2.5 Fuel Quality and Engine Performance

The compatibility of the plastic WDF with conventional compression ignition generator engines will depend on the similarity of the WDF to JP-8. The only certain method for testing the performance of a diesel-type fuel in a given engine is to use the fuel to power the engine and monitor the performance to determine the cetane number. Since engine testing is time-consuming and requires relatively large quantities of fuel, various performance indices calculated from fuel physical properties have been developed. One alternative is the cetane index, which is calculated using the results of a boiling point curve, the density, and the viscosity of the fuel. Unfortunately, we did not produce sufficient quantities of fuel in the laboratory to permit the measurement of boiling point curve and viscosity as required for the cetane index calculations.

Instead, we calculated the density and the viscosity using the property models from the HYSYS™ process software for a liquid having a composition similar to the pyrolysis liquids from the mixed plastic mordenite catalyst experiments.²⁶ There were a

²⁵ No gas sample was obtained for the mordenite 425°C experiment, so it was assumed that the gas composition was similar to the 400°C experiment. Since the bulk composition of the liquid from both runs at both temperatures is not significantly different, we believe that this is a reasonable assumption for the process design in Section 3. In any case, there is more gas generated than is needed to support the pyrolysis process, so there is a wide margin for error without affecting the design or cost.

²⁶ Pande, S.G. and D.R. Hardy. "A practical evaluation of published cetane indices." *Fuel* **69** (1990) 437-442.

significant fraction of unidentified compounds among the >200 peaks identified in the liquids analysis, so in the calculations we used only the top 80wt%, which in both cases was 42 compounds. The compounds in the final 20wt% of the liquid may influence the viscosity. The Calculated Carbon Aromaticity Index (CCAI) was calculated using the formula

$$CCAI = Density - 81 - 141 \times \log \log(kinematic\ visc. + 0.85)$$

with density in units of kg/m³ and kinematic viscosity in units of centistokes. Generally, the lower the CCAI, the better the performance of the fuel in a diesel engine since aromatics do not have favorable combustion characteristics for compression ignition engines. We did not find any specifications for JP-8 CCAI, however, Shell Oil has indicated that for heavier residual fuel oils, modern engines can accept fuels with CCAI ≤ 875.²⁷ Pande and Hardy (Ref. 26) developed a reasonable correlation for a modified CCAI with the experimentally determined cetane number for a set of 76 fuel samples. The modified CCAI is calculated using the formula

$$CCAI_{mod} = -(0.3656 \times CCAI) + 345.0875$$

The CCAI_{mod} values are intended to be used on a comparable scale as the cetane number, so typical values from range from 42-60. Some references do not indicate that there is a minimum cetane number specification for JP-8, but the average value of JP-8 has been reported to be ~45.²⁸ The CCAI and CCAI_{mod} for the two mixed plastic pyrolysis oils generated using mordenite catalyst (compositions listed in Table 21) are listed in Table 23. Both the measured and calculated density were used in the calculations to provide a range of CCAI values.

Table 23. CCAI and CCAI_{mod} values for waste plastic-derived fuels using mordenite catalyst.

Pyrolysis Temperature	Density Value	CCAI	CCAI_{mod}
400°C	842 kg/m ³ (measured)	848	34.9
	754 kg/m ³ (calculated)	760	67.2
425°C	845 kg/m ³ (measured)	844	36.5
	758 kg/m ³ (calculated)	757	68.3

It is interesting that the values listed in Table 23 span the entire range of diesel fuel quality from very low (35) through extremely high (68). The real cetane number of the waste-derived fuels is probably closer to the low value than to the high value since the

²⁷ Schenk, C., *et al.* "Ignition Quality of Residual Fuel Oils." Shell Marine Products Bulletin, undated.

²⁸ U.S. Army TACOM Report. *JP-8: The Single Fuel Forward.* May 2001, page 158.

feedstock contains 1/3 aromatic polymer (i.e., polystyrene), and aromatics lead to reduced cetane index. The wide disparity between the measured and calculated densities and the resulting CCAI values indicates that there may be a significant proportion of aromatic compounds in the high molecular weight fractions of the liquid. Aromatics generally have a higher density than the other compound types identified in the chromatographic analysis. The PIANO analysis identifies specific peaks up through only C₁₃ compounds, so for calculation purposes, the C₁₄₊ components are lumped as pseudocomponents with assumed properties of the alkanes. While the waste plastic derived fuels may not be premium quality JP-8 replacements, the CCAI and CCAI_{mod} values listed in Table 23 indicate that the WDF is in the proper range and certainly could be blended with conventional JP-8 supplies without significantly affecting the fuel quality. The CCAI_{mod} for the mordenite-derived fuels may be higher than would be assumed from the PIANO component split. Singly substituted isoparaffins such as the 3-methylnonane that is the most abundant component in both fuels have a high cetane index and low octane number, in contrast to multiply substituted isoparaffins which tend to have a low cetane index and high octane number.

3 Process Analysis and Design

Several possible system designs were considered for the conversion of mixed polymeric waste to gaseous and liquid hydrocarbon fuel. The performance of each potential system was quantified using process models. Possible variations on the process include:

- Batch vs. continuous processing
- Oil vs. gas production as fuel for internal combustion gensets

Of these systems, batch production of liquid fuel for electricity generation was selected to be studied in more detail, including system cost estimation. The batch system is well-adapted to small-scale, intermittent operation, and the use of liquid fuels for electricity production is compatible with existing military generator systems.

3.1 Batch Process for liquid-fueled IC Genset

Batch processing of the polymer waste is in many ways a more simple method than continuous processing and does not differ significantly from the experimental approach discussed in Section 2.3. Major disadvantages of batch processing (compared to continuous processing) are lower system efficiencies and increased fuel and waste storage requirements.

With a batch process, the possibilities exist for operating either a liquid-fueled or gas-fueled IC genset. Because the IC gensets currently used by the military would be able to run on the liquid product, which is similar to JP8, batch production for liquid fuel will be considered the baseline system for this study.

3.1.1 Process Description

A diagram of the proposed process is shown in Figure 18. Waste plastics are ground to small particles (~10mm length) and stored in a hopper. From the hopper, the plastics are hand-loaded into a gas-jacketed, stirred reaction vessel. The vessel and its contents are heated by a burner fed with gas product stored from a previous run. The reaction takes place at 425°C and ambient pressure, with the gaseous and vaporized products continuously exiting the reaction vessel to a condenser. The products are cooled to condense the oil, which is sent to a storage vessel. Some of the product gas is fed to a burner to supply heat for the reactor, while the remaining gas is compressed to 40-50 psig and cooled for storage in a two-phase (gas/liquid) state. When all of the polymer has been reacted and exhausted from the reactor, ambient air is blown through the jacket to rapidly cool the reactor. At 50°C or cooler, the reactor vessel is opened and loaded with the next batch of polymer. Since no appreciable residue is left from the reaction, the reactor can be run for many batches before cleaning is necessary.

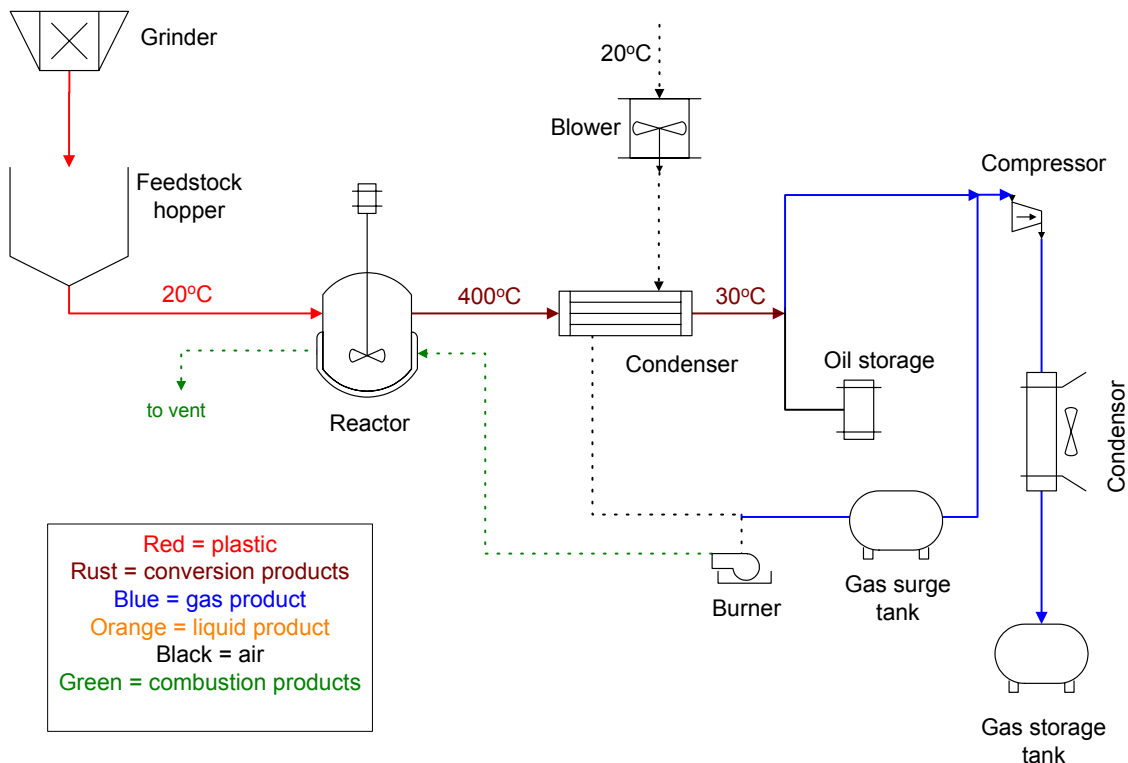

Figure 18. Schematic of basic system for batch processing.

All of the heating needs for the process are supplied by burning the gaseous product of the pyrolysis process. However, less than half of the product gas is actually needed with the result that much excess product gas is available for other uses.

Electrical loads for the process include the grinder and air blower. Since electricity is supplied from the genset running on the liquid pyrolysis product, electricity needs cut directly into process efficiency.

A process model was created to study the effects of batch size on system performance. Batch time was determined to be reasonably insensitive to batch size, with each batch taking roughly one hour. To achieve the targeted 5 kg/hr polymer process rate, a batch size of 5 kg was selected. The reactor was designed with an internal volume of 17 liters and manufactured from 27 kg of high temperature metal. This mass of metal includes the reactor gas jacket material for heating the reactor. The assumed operating conditions and model results are provided in Table 24.

Table 24. Process properties for batch production of liquid fuel from mixed plastics.

Batch size	5 kg mixed plastics
Reaction Temperature	425°C
Time for heat-up	155 seconds
Reaction time	2700 seconds
Cool down time	588 seconds
Total process time	3533 seconds (59 min)
Gross oil yield	3.55 kg (71% mass)
Gross gas yield	1.45 kg (29% mass)
Net oil yield	3.4 kg (68% mass)
Net gas yield	0.78 kg (16% mass)
Net oil energy	147 MJ (~42 kW avg)
Net gas energy	37 MJ (~10 kW avg)
Total process energy efficiency	83% (LHV basis)
IC genset avg power (@ $\eta=25\%$)	10.4 kW

3.1.2 System Design and Cost

A complete system bill of materials was established based on the modeled performance characteristics of the process. Figure 19 is a complete diagram of the proposed system, including all major components listed in the bill of materials (i.e., a more detailed version of the diagram in Figure 18). The system is small enough to fit onto a ¾-ton trailer.

Mass and energy balance models were used to specify the performance and size of each component. The cost of all components, excluding the reactor vessel, were established using off-the-shelf analogies. The reactor vessel cost was determined by using Design for Manufacture and Assembly (DFMA) techniques. These techniques, developed by G. Boothroyd and P. Dewhurst,²⁹ have been adapted by Directed Technologies, Inc. for creating accurate cost estimates for engineering designs. Production runs of 10 and 10,000 systems were considered. Appropriate discounts were applied for mass manufacturing at the 10,000 systems level.

Table 25 lists the complete system bill of materials with costs, including the trailer. A 20% engineering cost contingency was applied for cost conservatism to account for any unforeseen components or materials selection issues. The contribution of each

²⁹ Boothroyd, G., P. Dewhurst, W. Knight. Product Design for Manufacture and Assembly. Marcel Dekker Inc.: New York, 2002.

subsystem to the total cost is shown graphically in Figure 20 for both production volumes. The system does not include the cost of the genset since we have assumed that the existing military generators will be used. Additionally, a final manufacturer's markup has not been applied to these costs.

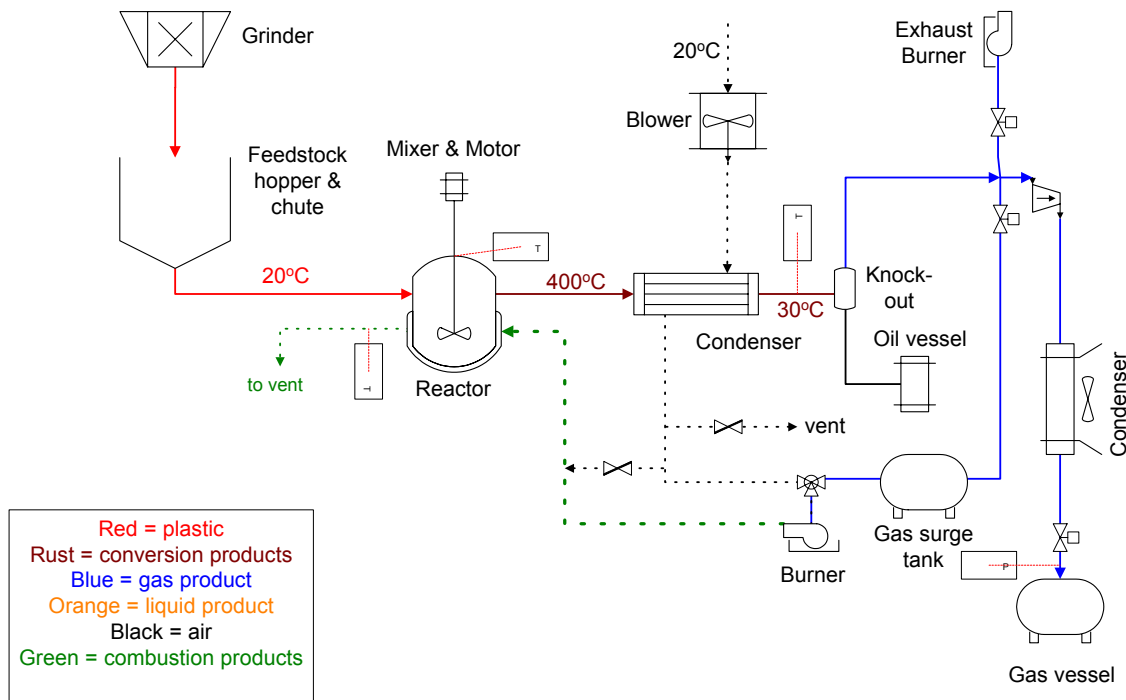

Figure 19. Detailed system diagram for batch processing for liquid fuel.

The equipment and piping was assumed to be constructed of stainless steel, with the exception of the reactor vessel. The reactor vessel was assumed to be Alloy 800H, which is more corrosion resistant than stainless steel at elevated temperatures. The process components were selected to survive typical industrial operating environments. There may be additional costs for 'ruggedizing' the system to withstand military field use, although the degree of additional ruggedness will depend on the ultimate use of the waste to fuel converters. For example, the durability needed for operation at the Ft. Irwin landfill may be far below the durability required in the field in the mountains of Afghanistan.

Table 25. Bill of materials for batch processor for liquid fuel.

Item	Cost	
	10 units	10,000 units
Feedstock Handling	\$7,904	\$6,535
Grinder	\$7,704	\$6,420
Hopper w/ manual trap	\$180	\$100
Chute	\$20	\$15
Processor	\$8,542	\$4,406
Jacketed Reaction Vessel (and insulation)	\$3,095	\$1,075
Mixer and motor	\$2,600	\$1,300
Burner	\$650	\$488
Burner mixer	\$70	\$53
Burner igniter	\$10	\$8
Condenser	\$500	\$100
Condenser/Burner Blower	\$195	\$130
Blower air filter	\$60	\$45
Butterfly valve and servo (burner bypass)	\$350	\$325
Butterfly valve and servo (to vent)	\$350	\$325
Tubing	\$200	\$150
Insulation	\$72	\$54
Butterfly valve and servo (to main burner)	\$350	\$325
Gas surge tank	\$40	\$30
Product Handling	\$1,940	\$1,436
Compressor	\$325	\$293
Compressor filter	\$50	\$40
Condenser (following compressor)	\$300	\$75
Condenser fan (following compressor)	\$52	\$39
Oil vessel (w/ manual valve)	\$80	\$65
Gas vessel (w/ manual valve)	\$45	\$40
Butterfly valve and servo (to exhaust burner)	\$350	\$325
Gas on-off solenoid valve at tank	\$48	\$39
Excess gas burner	\$650	\$488
Burner igniter	\$10	\$8
Exhaust line	\$30	\$25
Instrumentation and Controls	\$508	\$428
PLC	\$237	\$200
Jacket gas exhaust thermocouple	\$18	\$15
Rxn vessel thermocouple	\$18	\$15
Condenser thermocouple	\$18	\$15
Gas vessel pressure transducer	\$85	\$75
Wiring	\$100	\$82
Connectors and fasteners	\$33	\$26
Support and Exterior	\$995	\$730
Mounting hardware	\$580	\$435
Enclosure	\$415	\$295
Trailer	\$390	\$300
Final Assembly	\$1,122	\$561
20% Contingency	\$6,677	\$4,279
TOTAL	\$28,079	\$18,675

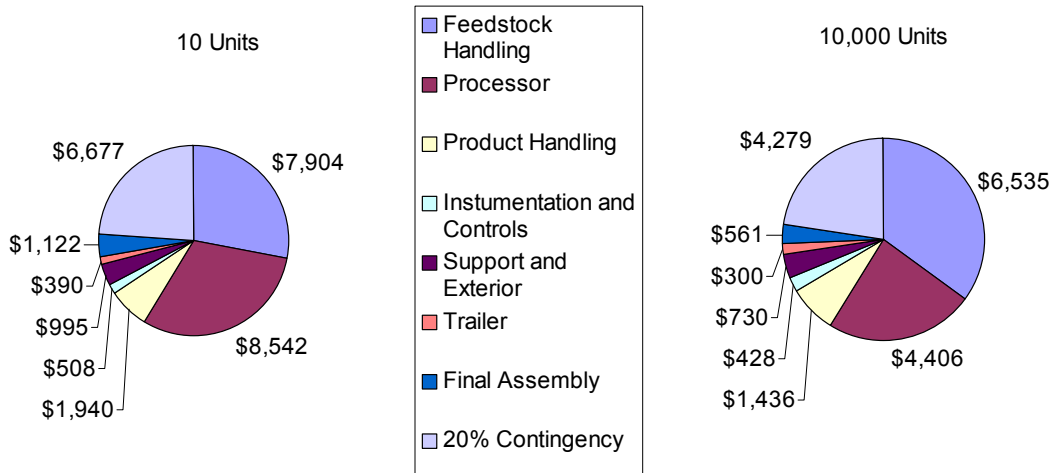

Figure 20. Contribution of subsystems to system cost for batch processor for liquid fuel.

3.2 Alternative Processes

3.2.1 Batch Process for Gas-fueled IC Genset

Because the liquid product is similar to JP-8 and has a multitude of military uses (including vehicle fuel and electricity production), the utility of the polymer to energy system may be improved over the baseline by utilizing an IC genset that operates on the gaseous hydrocarbon fuel (leaving liquid fuel product for other uses).

To optimize for this application, the design and operation of the system differs slightly from the baseline system described above. The reaction temperature is lowered to 400°C to increase the amount of gas produced (versus liquid) from the plastic feedstock. Despite these differences from the liquid fuel version, the general schematic of Figure 18 also applies to this system. Table 26 summarizes the operating parameters for the alternative system. Note that the electrical generating capacity of this system is much higher than indicated if the liquid product from the process is burned in a liquid-fueled genset ($3.3\text{kW} + 0.25 \cdot 43\text{kW} = 14\text{kW}$).

Because the operating conditions and performance of this system do not differ significantly from the baseline system, the costs are roughly equivalent. However, the need for gas-fueled IC gensets in addition to the liquid-fueled versions currently used may add cost and logistical burden to implement. These costs must be weighed against the operational benefits of this system.

Table 26. Process properties for batch process for gas fuel from mixed plastic.

Batch size	5 kg mixed plastics
Reaction Temperature	400°C
Time for heat-up	103 seconds
Reaction time	2700 seconds
Cool down time	385 seconds
Total process time	3277 seconds (55 min)
Gross oil yield	3.25 kg (65% mass)
Gross gas yield	1.75 kg (35% mass)
Net oil yield	3.25 kg (65% mass)
Net gas yield	0.95 kg (19% mass)
Net oil energy	141 MJ (~43 kW avg)
Net gas energy	44 MJ (~13 kW avg)
Total process energy efficiency	83% (LHV basis)
IC genset avg power (@ $\eta=25\%$)	3.3 kW (on gas only)

Tight integration with the IC genset can provide additional efficiency benefits since the waste heat from the genset can be used to help meet the heat requirements for the pyrolysis reactor, thus reducing the amount of product gas needed for this purpose. In such a system, some performance degradation may occur in the genset since the recovery of the exhaust gas will likely result in increased back pressure. Accurately estimating the efficiency of such an integrated system requires consideration of many factors and lies outside the scope of the current study.

3.2.2 Continuous Processes

Continuous processes are generally more efficient than batch processes due to the lack of frequent start-ups and shut-downs that characterize batch processing. However, aside from the losses associated with heating and cooling the equipment, the energy needs for heating and reacting the feedstock are virtually the same. Therefore, the continuous process efficiency can be estimated from the batch process analysis without its own rigorous analysis. In this case, continuous processing of 5 kg/hr feedstock for liquid fuel is estimated to have a total efficiency of 89%³⁰ and an oil production efficiency of 70%, yielding 3.5 kg/hr of oil and 1 kg/hr of product gas. These production values should be considered maxima for these process conditions since the inevitable startups, shutdowns, and throughput variability will all result in decreased efficiency.

³⁰ All efficiencies are provided on a lower heating value (LHV) basis.

Another advantage of continuous processing over batch processing is its steady-state nature with regard to handling of the products. While in a batch process the condenser, condenser fan, and gas compressor must be sized for the maximal product flow, in the continuous design these items can be sized for the average, steady-state flow (in this case, as low as 1/3 the maximal baseline rate). This reduces the size, mass, and cost of these components. Furthermore, if the continuous reactor design was coupled with a continuously running genset, the requirements for gas and liquid product storage could be dramatically decreased since the products would be consumed immediately.

Much of the equipment required for a continuous waste-to-fuel processor differs significantly from the batch version. For example, a continuous feeding mechanism is required to deliver the ground feedstock from the hopper to the reaction vessel. This feeder must permit little or no air to enter the reactor. To fulfill this function, a heated screw extruder would likely be used to remove ground, solid feedstock from the hopper and deliver hot, liquid polymer to the reactor.

In the batch design, the reactor vessel acts as heater, reactor, and gas-liquid separator. In a continuous process, it may be necessary to perform each of these steps in separate, serial sections. This would undoubtedly contribute additional cost over the batch reactor.

These points are meant to illustrate that continuous reactor design offers both advantages and disadvantages over batch design. Which design is deemed best depends on the specific application of the reactor. However, for general applicability, the batch reactor may offer the greatest flexibility by accommodating generators which are run sporadically or at variable capacity.

4 Conclusions and Recommendations

4.1 Laboratory Validation of Plastics-to-Fuel Conversion

The liquid fuel produced from the mixed plastic waste, although not identical to JP-8, is similar both in distribution of carbon number and heating value to JP-8. The most important characteristic for the waste-derived fuel (WDF) will be the compatibility with the existing generator engines, which depends primarily on the heat of combustion, density, and possibly the cetane index compared to JP-8. These and other properties of interest for JP-8 and the corresponding values for the plastic-derived pyrolysis liquids are listed in Table 27 and Table 28. The fuel derived from mixed plastic waste using mordenite catalyst is very similar to JP-8, although the cetane index for the WDF may be at the low end of the acceptable range for logistics fuels.

Table 27. Comparison of pyrolysis liquid product properties with JP-8 specifications.

Property	JP-8 Spec	Mixed Plastic, Mordenite Catalyst 425°C	Mixed Plastic, Mordenite Catalyst 400°C	Mixed Plastic, HZSM-5 catalyst 400°C	Polypropylene, HZSM-5 catalyst 350°C
Aromatics (vol%)	≤ 25	13.5	8.9	29.3	31.6
Naphthalenes (vol%)	≤ 3	0.145	0.085	0.45	~0
Sulfur (ppmw)	≤ 3,000	0	0	0	0
Density (g/L)	775-840	841	842	883	810
Net heat of combustion (MJ/kg)	≥ 42.8	44.0	44.0	40.6-43.2	42.8
API Gravity	37-51	36	37	30	42
Approx. Chemical Formula	C ₁₁ H ₂₂	C ₁₀ H _{20.6}	C _{9.8} H ₂₀	C ₉ H ₁₇	C ₈ H ₁₄
Research octane number	N/A	64	59	80	92
Cetane index	~45	36-68	35-67	not applicable	not applicable

Table 28. Summary of plastic waste-derived fuel compositions.

Mass%	Mixed Plastic, Mordenite Catalyst 425°C	Mixed Plastic, Mordenite Catalyst 400°C	Mixed Plastic, HZSM-5 catalyst 400°C	Polypropylene, HZSM-5 catalyst 350°C
Paraffins	29.4	23.6	23.8	11.5
Isoparaffins	39.4	46.5	22.3	17.8
Aromatics	10.3	8.9	31.1	35.3
Naphthenics	9.2	9.1	12.5	18.7
Olefins	7.9	8.4	7.4	15.8
Unknowns/C ₂₆₊	3.7	3.6	2.9	1.0

As shown in Table 28, the composition of the pyrolysis liquids depends strongly both on the type of catalyst and feedstock. Singly substituted isoparaffins such as methylnonane (the primary component in the mordenite liquids) have a high cetane index and low octane number, in contrast to multiply substituted isoparaffins which tend to have a low cetane index and high octane number.

The high aromatic content of the fuels from the HZSM-5 catalyst would lead to poor performance in a diesel engine, but excellent performance (i.e., high octane number) in a gasoline engine. The HZSM-5 liquids are virtually indistinguishable from standard unleaded gasoline and potentially could be blended with logistics fuels if the volumes of waste derived fuel are small relative to the total fuel usage or if gasoline-powered equipment were available.

The gas products from pyrolysis may provide a second valuable fuel. The properties of the gas products from plastics pyrolysis are similar to natural gas liquids or butane, so the gas could be easily converted to a compressed liquid for compact storage. The nitrogen sweep gas used in the laboratory apparatus acts as an inert diluent, so in actual practice, the “gas phase” components may be collected as liquid. The lumped compositions of the gas products from plastics pyrolysis are listed in Table 29, with typical LPG composition included for reference.

4.2 Process Design and Cost

Batch production of liquid fuel for electricity generation was selected as the basis for a detailed process design. The batch system is well-adapted to small-scale, intermittent operation, and the use of liquid fuels for electricity production is compatible with existing military generator systems. Continuous systems would have a slight efficiency advantage, but if the waste conversion process were operated for only a fraction of time, startup and shutdown activities would consume a significant fraction of the recovered energy.

Table 29. Pyrolysis gas product compositions.

Component	Composition, Mole %		
	Mixed Plastic, Mordenite catalyst	Mixed Plastic, HZSM-5 catalyst	Polypropylene, HZSM-5 catalyst
C ₆₊	37.1	13.8	19.9
C ₄ alkenes	21.0	11.0	19.4
C ₅ alkanes	15.2	8.3	13.6
C ₃ H ₆	13.6	23.4	11.7
C ₃ H ₈	5.2	8.1	10.2
C ₄ alkanes	3.0	31.0	22.9
C ₂ H ₆	2.4	0.9	0.3
C ₂ H ₄	0.9	3.2	1.9
Others	1.7	0.4	0.2
Molecular weight	58	52	57
Average molecular formula	C ₄ H _{9.2}	C _{3.6} H ₈	C ₄ H ₉
Lower heating value	20,021 Btu/lb (46.4 MJ/kg)	19,742 Btu/lb (45.8 MJ/kg)	19,801 Btu/lb (45.9 MJ/kg)

The manufacture of trailer-mounted batch mixed plastic to liquid fuel conversion systems was considered at two production levels: 10 units and 10,000 units. The costs for production of the converter units were estimated using modified Design for Manufacturing and Assembly (DFMA) techniques. The DFMA approach has been adapted by Directed Technologies to estimate manufacturing costs for similar conceptual systems related to energy conversion or fuel cells. The estimated costs for the batch waste converter at both production levels are listed in Table 30. At a fuel cost of \$18/gallon in the field (brigade location), with widespread adoption (10,000 unit production run) the simple payback period for the waste converter is ~6 months (assuming 50% average output for the typical 5kW generator).

Of course, the economics of the waste-to-fuel conversion are more complicated than the simple payback calculation. The military field waste-to-fuel converter needs to be considered in the context of all logistics operations, including waste handling, fuel delivery, and electricity generation. The decision about what waste feedstocks to use, whether to use a batch or continuous converter, and what properties of the fuels are most critical are all inter-related. For example, if the waste-derived fuels are used to generate electricity immediately after the conversion step, then the fuel stability requirements and all property spec related to fuel stability could be relaxed.

Table 30. Estimated costs for plastic waste-to-fuel converter at low (10 units) and high (10,000 units) production levels.

Subsystem	Cost at Production Level	
	10 units	10,000 units
Feedstock handling	\$7,904	\$6,535
Processor	\$8,542	\$4,406
Product handling	\$1,940	\$1,436
Instruments and controls	\$508	\$428
Support and exterior	\$995	\$730
Trailer	\$390	\$300
Final assembly	\$1,122	\$561
Cost contingency (20%)	\$6,677	\$4,279
Total	\$28,079	\$18,675

4.3 Recommendations

The experiments detailed in this report demonstrate that producing logistics-compatible fuels from plastic waste streams is feasible with conventional thermal processing and that the yields and fuel quality are relatively high with reasonable-cost equipment. There are factors that remain to be optimized and could benefit from additional study, including:

- Choice of catalyst to yield narrow range of fuel properties or flexibility with varied waste feedstocks.
- Linking the fuel generation to the electricity production to achieve higher overall efficiency.

The ability to influence the fuel properties simply by using a different commercially-available zeolite catalyst is an important factor that can be exploited in a scaled-up system. The simple switch from HZSM-5 to mordenite, both commercially available inexpensive catalysts, resulted in a dramatic shift in fuel composition. The high-quality fuels generated using mordenite and HZSM-5 catalysts gives confidence to the possibility of identifying a commercial catalyst for conversion of simple mixed plastic waste mixtures without embarking on an extensive catalyst design program.

A demonstration of a full-scale *stationary* process would be the logical next step. A stationary system would be easier to construct and modify in a development mode than would a trailer-mounted system. Segregated plastic wastes may be available at a military base that operates a waste recycling program, allowing for more real-world tests of the process capabilities.

APPENDIX A: Cellulose Fluff Oil/Wax NMR Traces

Analysis conducted by the laboratory of Dr. Art Ragauskas at the Georgia Tech Institute of Paper Science and Technology.

Sample 1: Pyrolysis Oil (liquid product) ^{13}C NMR

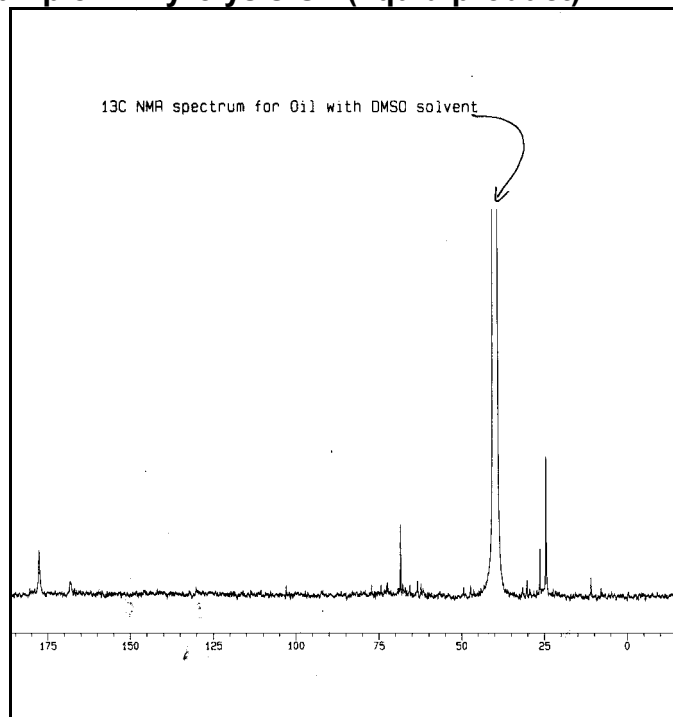

Sample 1: Pyrolysis Oil (liquid product) ^1H NMR

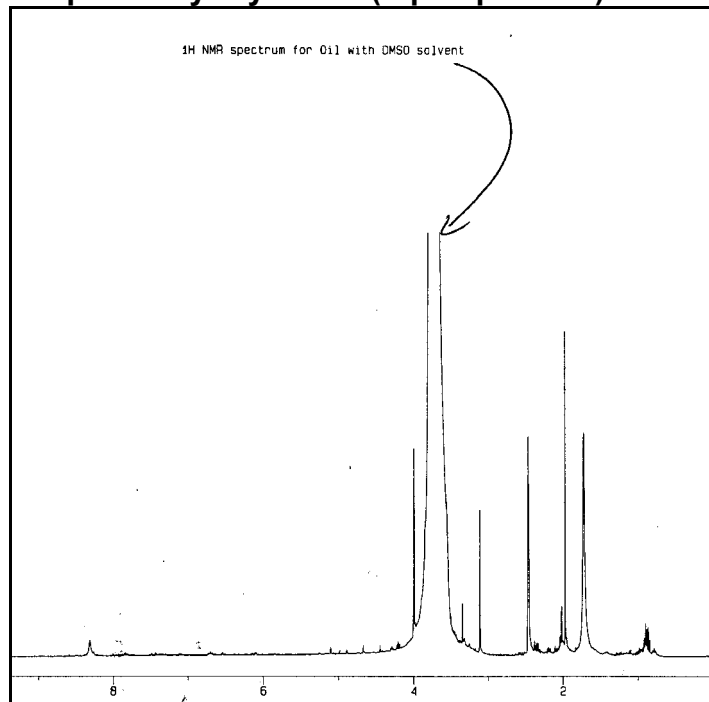

Sample 2: Pyrolysis Wax (non-char solid product) ^{13}C NMR

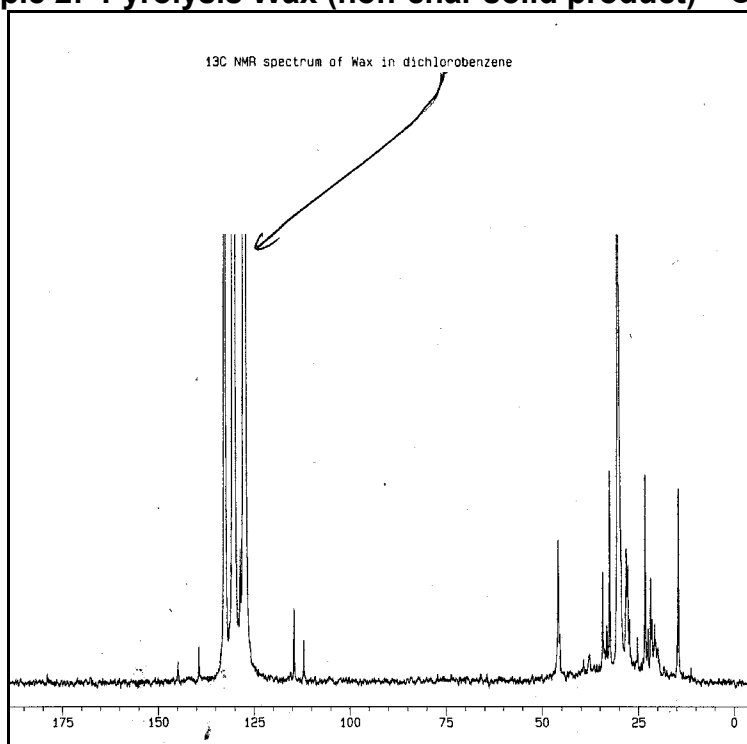

Sample 1: Pyrolysis Oil (liquid product) ^1H NMR

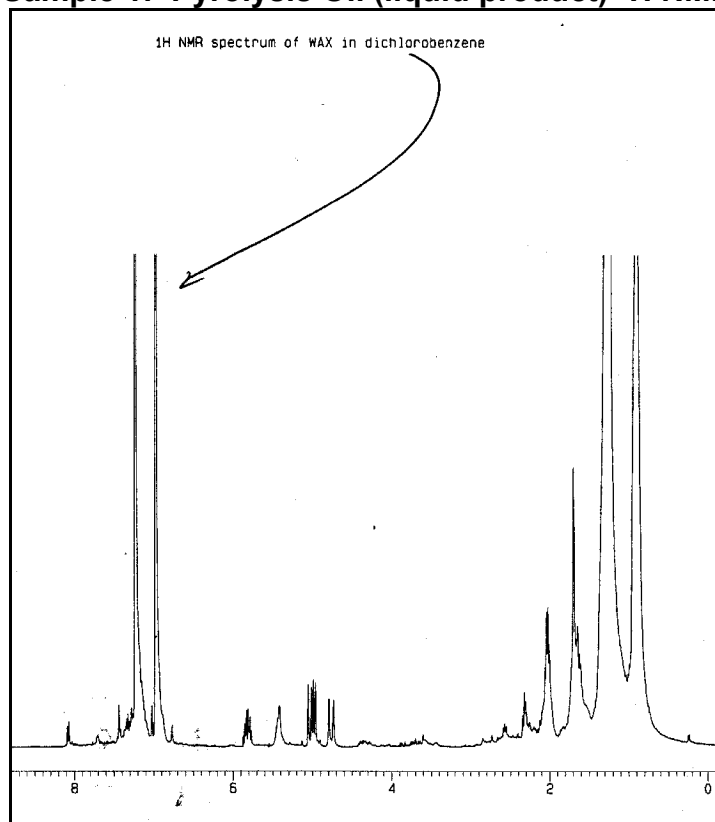

APPENDIX B: Analysis of Mixed Plastic-Derived Liquids by SPL, Inc.
 Report of analysis of liquid sample from mixed plastic experiment at 425°C with mordenite catalyst. (includes top 50 components representing 82.0wt%)

SPL Analysis of Samples from 20 May 2004 Run

Mixed plastic pyrolysis at 425C, Mordenite catalyst

N=naphthenes

I=isoparaffins

A=aromatics

O=olefins

P=paraffins

Sample type liquid
 Sample ID 052004-01

Component	MW	Wt %	Mole %
3-methyloctane	128.29	25.812	28.467
C18	254.56	8.912	4.953
2-methylnonane	142.32	3.570	3.549
C17	240.53	3.479	2.046
C26+	366.80	3.330	1.287
2,6-dimethylheptane	128.29	2.736	3.017
C14	198.44	2.629	1.874
ethylbenzene	106.18	2.622	3.494
toluene	93.16	2.360	3.623
ethylcyclohexane	112.24	1.833	2.311
C20	282.62	1.714	0.858
n-dodecane	170.38	1.662	1.381
n-tridecane	184.41	1.629	1.249
C19	268.59	1.458	0.768
C25	352.77	1.213	0.487
C16	226.50	1.201	0.750
C15	212.47	1.164	0.775
benzene	78.12	0.867	1.570
C24	338.74	0.818	0.342
n-undecane	156.35	0.727	0.658
N6	126.27	0.725	0.913
N4	126.27	0.653	0.823
1c,2c,3-trimethylcyclopentane	112.24	0.652	0.822
N8	126.27	0.627	0.702
3-methyl-t-hexene-3	98.21	0.586	0.844
2-methylpentene-2	84.18	0.542	0.912
2,5,5-trimethylheptane	142.32	0.515	0.512
n-octane	114.26	0.495	0.613
N13	126.27	0.466	0.522
hexene-1	84.18	0.462	0.776
n-decane	142.32	0.445	0.443
i-propylbenzene	120.21	0.440	0.517
t-octene-4	112.24	0.438	0.552
1-methyl-4-i-propylbenzene	134.24	0.409	0.431
n-heptane	100.23	0.408	0.577
I42	156.35	0.359	0.324
n-nonane	128.29	0.355	0.391
c-nonene-3	126.27	0.335	0.376
I28	142.32	0.314	0.284
c-heptene-3	98.21	0.309	0.446
1c/t,3-hexadiene	82.16	0.304	0.524
I47	170.38	0.293	0.243
C21	296.65	0.283	0.135
I36	156.35	0.279	0.253
1,2-dimethyl-3-ethylbenzene	134.24	0.275	0.290
1,1,2-trimethylcyclopentane	112.24	0.273	0.344
n-propylcyclopentane	112.24	0.264	0.332
c-heptene-2	98.21	0.263	0.378
2,3-dimethylpentene-2	98.21	0.262	0.377
? (assume C18 alkene)	252.54	0.256	0.151

Report of analysis of liquid sample from mixed plastic experiment at 400°C with mordenite catalyst. (includes top 50 components representing 82.6wt%)

SPL Analysis of Samples from 23 April 2004 Run

Mixed plastic pyrolysis at 400C, Mordenite catalyst

N=naphthenes

I=isoparaffins

A=aromatics

O=olefins

P=paraffins

Sample type

liquid

Sample ID

042304-02

Component	MW	Wt %	Mole %
3-methyloctane	128.29	30.420	32.574
C18	254.56	7.687	4.148
C17	240.53	3.911	2.234
2-methylnonane	142.32	3.591	3.466
C26+	366.80	3.567	1.339
2,6-dimethylheptane	128.29	3.521	3.771
toluene	93.16	2.305	3.436
C14	198.44	2.294	1.588
ethylcyclohexane	112.24	2.114	2.587
ethylbenzene	106.18	1.914	2.476
C16	226.50	1.135	0.689
n-tridecane	184.41	1.128	0.840
n-dodecane	170.38	1.045	0.842
C19	268.59	0.846	0.433
benzene	78.12	0.814	1.431
N6	126.27	0.813	0.995
4-methylheptane	114.26	0.767	0.923
n-undecane	156.35	0.762	0.669
N4	126.27	0.722	0.883
C20	282.62	0.722	0.351
C24	338.74	0.712	0.289
2-methyl-2-hexene	98.21	0.643	0.899
C15	212.47	0.636	0.411
N8	126.27	0.630	0.685
2,5,5-trimethylheptane	142.32	0.603	0.582
2-methylpentene-2	84.18	0.567	0.925
n-octane	114.26	0.533	0.641
c-nonene-2	126.27	0.478	0.520
3,3-diethylpentane	128.29	0.470	0.503
n-decane	142.32	0.454	0.438
hexene-1	84.18	0.421	0.688
t-octene-3	112.24	0.389	0.476
n-heptane	100.23	0.387	0.530
1-methyl-4-i-propylbenzene	134.24	0.384	0.393
I8	128.29	0.375	0.401
I28	142.32	0.368	0.323
c-heptene-3	98.21	0.365	0.510
N17	126.27	0.365	0.397
1c/t,3-hexadiene	82.16	0.344	0.575
n-propylcyclopentane	112.24	0.327	0.400
C23	324.71	0.319	0.135
1,1,2-trimethylcyclopentane	112.24	0.318	0.389
C21	296.65	0.316	0.147
o-xylene	106.18	0.311	0.402
I36	156.35	0.307	0.270
3-methyl-t-hexene-3	98.21	0.299	0.418
O52	112.24	0.298	0.364
2-methyloctane	128.29	0.297	0.318
C22	310.68	0.286	0.127
2,3-dimethylpentene-2	98.21	0.281	0.393

Report of analysis of liquid sample from mixed plastic experiment at 400°C with HZSM-5 catalyst. (includes top 50 components representing 86.2wt%)

SPL Analysis of Samples from 16 April 2004 Run

Mixed plastic pyrolysis at 400C, HZSM5 catalyst

N=naphthenes

I=isoparaffins

A=aromatics

O=olefins

P=paraffins

Sample type liquid
Sample ID 041604-01

Component	MW	Wt %	Mole %
1c,2c,4c-trimethylcyclohexane	126.27	8.308	8.435
benzene	78.12	7.899	12.962
1,1,4-trimethylcyclohexane	126.27	6.564	6.664
C14	198.44	6.423	4.149
toluene	93.16	6.362	8.850
C18	254.56	3.928	1.978
C17	240.53	3.426	1.826
2,3-dimethylheptane	128.29	2.903	2.901
p-xylene	106.18	2.831	3.418
2-methylnonane	142.32	2.636	2.375
C26+	366.80	2.569	0.900
3-ethylnonane	156.35	2.064	1.693
n-dodecane	170.38	1.919	1.444
1-methyl-3-ethylbenzene	120.21	1.860	1.983
I40	156.35	1.789	1.467
C19	268.59	1.573	0.751
1-methyl-3-n-butylbenzene	148.27	1.559	1.348
N26	140.30	1.502	1.373
I6	128.29	1.458	1.457
n-propylbenzene	120.21	1.425	1.520
2,3-dihydroindene	118.19	1.322	1.433
1,2,4-trimethylbenzene	120.21	1.185	1.263
c-nonene-2	126.27	1.118	1.136
C24	338.74	1.000	0.379
I44	170.38	0.968	0.729
C20	282.62	0.903	0.410
C15	212.47	0.631	0.381
2,3,4-trimethylpentane	114.26	0.629	0.705
i-propylcyclopentane	112.24	0.568	0.649
N6	126.27	0.565	0.645
4,4-dimethyl-t-pentene-2	98.21	0.515	0.673
c-heptene-3	98.21	0.503	0.656
1,2-dimethyl-3-ethylbenzene	134.24	0.472	0.451
2-methylpentene-2	84.18	0.453	0.689
3-methylheptane	114.26	0.446	0.501
2-methylnaphthalene	142.21	0.444	0.397
n-heptane	100.23	0.435	0.557
I39	156.35	0.428	0.351
A3	148.27	0.419	0.362
naphthalene	128.18	0.418	0.418
n-pentylbenzene	148.27	0.417	0.361
1-methylcyclopentene	82.16	0.405	0.632
1-methyl-4-n-propylbenzene	134.24	0.402	0.384
I32	142.32	0.402	0.334
2,3-dimethylpentene-2	98.21	0.381	0.497
n-butylbenzene	134.24	0.370	0.353
C21	310.68	0.359	0.156
methylcyclopentane	84.18	0.353	0.538
2-methyl-2-hexene	98.21	0.342	0.447
C16	226.50	0.342	0.194

Report of analysis of liquid sample from polypropylene experiment at 350°C with HZSM-5 catalyst. (includes top 50 components representing 73.7wt%)

SPL Analysis of Samples from 13 January 2004 Run

Polypropylene pyrolysis at 350C, HZSM5 catalyst

N=naphthenes

I=isoparaffins

A=aromatics

O=olefins

P=paraffins

Sample type	liquid			
Sample ID	Jan liquid			
Component	MW	Wt %	Mole %	
p-xylene	106.18	7.511	7.824	
m-xylene	106.18	6.090	6.343	
toluene	93.16	5.723	6.869	
1-methyl-4-ethylbenzene	120.21	4.886	4.496	
N26	140.30	4.522	3.565	
ethylbenzene	106.18	2.318	2.414	
o-xylene	106.18	2.294	2.389	
1,2,4-trimethylbenzene	120.21	2.279	2.097	
O52	112.24	2.101	2.071	
2,3,4-trimethylpentane	114.26	1.800	1.743	
2-methylpentane	86.20	1.590	2.041	
C14	198.44	1.457	0.812	
n-nonane	128.29	1.346	1.160	
2-methylhexane	100.23	1.329	1.467	
n-heptane	100.23	1.316	1.453	
n-dodecane	170.38	1.298	0.843	
3-methylhexane	100.23	1.183	1.306	
1,4-diethylbenzene	134.24	1.158	0.024	
2t-ethylmethylcyclopentane	112.24	1.134	1.118	
methylcyclopentane	84.18	1.069	1.405	
c-pentene-2	70.15	0.988	1.558	
n-undecane	156.35	0.980	0.783	
n-tridecane	184.41	0.968	0.580	
n-hexane	86.20	0.954	1.224	
1-methyl-3-n-propylbenzene	134.24	0.951	0.783	
O28	98.21	0.881	0.992	
t-heptene-3	98.21	0.856	0.964	
4-methylheptane	114.26	0.828	0.802	
1-methylcyclopentene	82.16	0.813	1.095	
3-methyl-t-pentene-2	84.18	0.813	1.068	
1,1,4-trimethylcyclohexane	126.27	0.785	0.687	
t-hexene-2	84.18	0.765	1.006	
I32	142.32	0.762	0.546	
O46	112.24	0.743	0.837	
3-methylpentane	86.20	0.699	0.897	
I40	156.35	0.671	0.031	
C18	254.56	0.639	0.277	
2-methylheptane	114.26	0.619	0.599	
2,2-dimethylheptane	128.29	0.618	0.533	
3c-ethylmethylcyclopentane	112.24	0.609	0.595	
unknown #2	128.29	0.584	0.576	
c-heptene-3	98.21	0.574	0.647	
1c,3-dimethylcyclopentane	98.21	0.569	0.641	
C16	226.50	0.558	0.273	
2,2,3-trimethylhexane	128.29	0.534	0.460	
1t,3-dimethylcyclopentane	98.21	0.531	0.598	
2,3-dimethylhexane	114.26	0.527	0.510	
n-octane	114.26	0.506	0.490	
1-nonene	126.27	0.501	0.439	
3-methylcyclopentene	82.16	0.497	0.669	

APPENDIX C: Analysis of Mixed Plastic-Derived Gases by SPL, Inc.
 Report of analysis of gas sample from mixed plastic experiment at 400°C with mordenite catalyst.

SPL Analysis of Samples from 23 April 2004 Run

Mixed plastic pyrolysis at 400C, Mordenite catalyst

Sample type	gas	
Sample ID	042304-01	
	Mole %	Mass%
Component	042304-01	042304-01
H2	0.00	0.00
CO2	0.34	0.25
CO	0.00	0.00
C2H4	1.88	0.89
C2H2	0.00	0.00
C3H6	19.25	13.60
O2	0.00	0.00
N2	0.00	0.00
CH4	5.18	1.40
C2H6	4.68	2.37
C3H8	7.07	5.24
i-C4H10	1.21	1.18
C3H4	0.00	0.00
n-C4H10	1.87	1.83
1-C4H8	16.64	15.68
neo-C5H12	0.00	0.00
t-2-C4H8	3.14	2.96
c-2-C4H8	2.32	2.18
1,3-C4H6	0.17	0.16
i-C5H12	0.59	0.72
n-C5H12	11.92	14.45
C6+	23.72	37.11

SPL Heating Value Analysis (60F, 14.696 psia)

As-received LHV	474.1	Btu/ft3
Mole % combustibles	15.497	
Corrected LHV	3,059	Btu/ft3
Combustibles density	0	lb/ft3
Mass LHV	20,021	Btu/lb

Report of analysis of gas sample from mixed plastic experiment at 400°C with HZSM-5 catalyst.

SPL Analysis of Samples from 19 February 2004 Run
Mixed plastic pyrolysis at 400C

Component	Mole % 021904-01	Mass% 021904-01
H2	0.00	0.00
CO2	0.12	0.10
CO	0.00	0.00
C2H4	6.03	3.23
C2H2	0.00	0.00
C3H6	29.13	23.43
O2	0.00	0.00
N2	0.00	0.00
CH4	1.08	0.25
C2H6	1.52	0.87
C3H8	9.60	8.09
i-C4H10	6.35	7.05
C3H4	0.00	0.00
n-C4H10	3.56	3.95
1-C4H8	17.82	19.11
neo-C5H12	0.00	0.00
t-2-C4H8	6.17	6.61
c-2-C4H8	4.83	5.18
1,3-C4H6	0.04	0.05
i-C5H12	2.31	3.19
n-C5H12	3.70	5.10
C6+	7.73	13.76

SPL Heating Value Analysis (60F, 14.696 psia)

As-received LHV	801.6	Btu/ft3
Mole % combustibles	29.7	
Corrected LHV	2,700	Btu/ft3
Combustibles density	0.137	lb/ft3
Mass LHV	19,742	Btu/lb

Report of analysis of gas sample from polypropylene experiment at 350°C with HZSM-5 catalyst.

SPL Analysis of Samples from 13 January 2004 Run

Polypropylene pyrolysis at 350C

Component	Mole % 011304-01	Mole % 011301-02	Average
C3H6	15.37	16.68	16.03
i-C4H10	15.60	15.96	15.78
C3H8	13.65	13.10	13.37
C6+	12.88	11.70	12.29
1-C4H8	11.90	12.59	12.25
i-C5H12	6.72	7.29	7.01
n-C4H10	6.84	6.98	6.91
t-2-C4H8	4.17	4.28	4.23
C2H4	3.75	4.06	3.91
n-C5H12	4.34	3.35	3.85
c-2-C4H8	3.37	3.49	3.43
C2H6	0.79	0.33	0.56
CH4	0.45	0.00	0.22
CO2	0.15	0.19	0.17
H2	0.00	0.00	0.00
CO	0.00	0.00	0.00
C2H2	0.00	0.00	0.00
O2	0.00	0.00	0.00
N2	0.00	0.00	0.00
C3H4	0.00	0.00	0.00
neo-C5H12	0.00	0.00	0.00
1,3-C4H6	0.00	0.00	0.00

SPL Heating Value Analysis (60F, 14.696 psia)

As-received LHV	823	731.9	777.5
Mole % combustibles	27.6	24.7	26.2
Corrected LHV	2,978	2,958	2,968
Combustibles density	0.150	0.149	0.150
Mass LHV	19,813	19,789	19,801