

6097



**U.S. Army
Environmental
Center**

Composting of Nitrocellulose Fines - Technical and Logistical Feasibility

TECHNOLOGY IDENTIFICATION
FINAL REPORT

Report No. SFIM-AEC-ETD-CR-95028
Contract No. DACA31-91-D-0079
Task Order No. 0011

DISTRIBUTION STATEMENT A
Approved for Public Release
Distribution Unlimited

April 1995

Prepared for:
U.S. Army Environmental Center
SFIM-AEC-ETD
Aberdeen Proving Ground, MD 21010-5401

Prepared by:
Roy F. Weston, Inc.
1 Weston Way
West Chester, Pennsylvania 19380-1499

20041025 073

WESTON
MANAGERS DESIGNERS/CONSULTANTS



**COMPOSTING OF NITROCELLULOSE FINES -
TECHNICAL AND LOGISTICAL FEASIBILITY**

TECHNOLOGY IDENTIFICATION

FINAL REPORT

April 1995

Contract No. DACA 31-91-D-0079
Task Order 0011

Prepared for

U.S. ARMY ENVIRONMENTAL CENTER
SFIM-AEC-ETD
Aberdeen Proving Ground, MD 21010-5401

Prepared by

ROY F. WESTON, INC.
One Weston Way
West Chester, PA 19380-1499

Work Order No. 02281-012-011-0030

REPORT DOCUMENTATION PAGE		Form Approved OMB No. 0704-0188	
Public reporting burden for this collection of information is estimated to average 1 hour per response, including the time for reviewing instructions, searching existing data sources, gathering and maintaining the data needed, and completing and reviewing the collection of information. Send comments regarding this burden estimate or any other aspect of this collection of information, including suggestions for reducing this burden to Washington Headquarters Services, Directorate for Information Operations and Reports, 1215 Jefferson Davis Highway, Suite 1204, Arlington, VA 22202-4302, and to the Office of Management and budget, Paperwork Reduction Project (0704-0188), Washington, DC 20503.			
1. AGENCY USE ONLY (Leave Blank)		2. REPORT DATE March 1995	5. REPORT TYPE AND DATES COVERED Final, November 1994 - March 1995
4. TITLE AND SUBTITLE Composting of Nitrocellulose Fines - Technical and Logistical Feasibility, Technology Identification Report		8. FUNDING NUMBERS	
6. AUTHOR(S) J. Picciotti, J. O. Hammell, W. L. Lowe			
7. PERFORMING ORGANIZATION NAME(S) AND ADDRESS(ES) Roy F. Weston, Inc. One Weston Way West Chester, PA 19380		8. PERFORMING ORGANIZATION REPORT NUMBER	
9. SPONSORING/MONITORING AGENCY NAMES(S) AND ADDRESSES(ES) U. S. Army Environmental Center SFIM-AEC-ETD Aberdeen Proving Ground, MD 21010-5401		10. SPONSORING/MONITORING AGENCY REPORT NUMBER SFIM-AEC-ETD-CR-95028	
11. SUPPLEMENTARY NOTES Project Officer: Wayne Sisk, (410) 612-6851			
12a. DISTRIBUTION/AVAILABILITY STATEMENT Unlimited Local Reproduction Encouraged		12B. DISTRIBUTION CODE	
13. ABSTRACT (Maximum 200 words) The U.S. Army Environmental Center (USAEC) is evaluating treatment options, such as composting, for residual solids, or fines, from the production of nitrocellulose (NC), a highly substituted cellulose fiber used as a propellant. Previous testing by USAEC indicated that low levels of NC in soils can be treated by composting. USAEC has recently conducted reactivity testing to evaluate levels of NC which can be safely incorporated into compost. This Technology Identification Report (TIR) reviews other technologies for the treatment of NC fines. A literature review was conducted to identify potentially applicable technologies for NC fines treatment. Treatment technologies potentially applicable to NC fines at present include thermal destruction (incineration or open burning), alkaline hydrolysis, supplemental fuel firing and composting. Thermal destruction has been most extensively used in the past. This approach may come under tighter regulatory control due to nitrogen emissions and disfavor of open burning. Alkaline hydrolysis has been known for a number of years, but this approach has not been fully developed. Supplemental fuel firing and composting have promise based upon laboratory pilot testing. Further development is required for either approach. Supplemental fuel methods need to address air emissions. For composting, requirements for disposal of the final residue must be evaluated.			
14. SUBJECT TERMS Propellant, Nitrocellulose, Composting, Treatment		15. NUMBER OF PAGES 36	
		16. PRICE CODE	
17. SECURITY CLASSIFICATION OF REPORT Unclassified		18. SECURITY CLASSIFICATION OF THIS PAGE Unclassified	19. SECURITY CLASSIFICATION OF ABSTRACT Unclassified
		20. LIMITATION OF ABSTRACT	

TABLE OF CONTENTS

<u>Section</u>	<u>Title</u>	<u>Page</u>
ES	EXECUTIVE SUMMARY	ES-1
1	INTRODUCTION	1-1
	1.1 Background	1-1
	1.2 Characteristics of Nitrocellulose Fines	1-2
2	LITERATURE SEARCH	2-1
	2.1 Methodology	2-1
	2.2 Regulatory Status	2-2
	2.3 Technology Screening Criteria	2-4
	2.4 Identification of Candidate Technologies	2-5
3	REVIEW OF CANDIDATE TECHNOLOGIES	3-1
	3.1 Thermal Treatment	3-1
	3.1.1 Incineration	3-1
	3.1.2 Open Burning/Open Detonation	3-3
	3.2 Alkaline Hydrolysis	3-4
	3.3 Supplemental Fuel	3-8
	3.4 Biological Treatment by Composting	3-10
4	COMPARATIVE EVALUATION OF TECHNOLOGIES	4-1
5	CONCLUSIONS	5-1
6	REFERENCES	6-1



LIST OF FIGURES

<u>Figure</u>	<u>Title</u>	<u>Page</u>
3-1	Process Schematic for Fluidized Bed Incineration	3-2
3-2	Chronological NO _x -N Yield Relative to Alkali Form	3-5
3-3	Chronological NO _x -N Yield Relative to Alkali Dose	3-5
3-4	Chronological NO _x -N Yield Relative to Hydrolysis Temperature	3-5
3-5	Process Schematic for Alkaline Hydrolysis	3-7
3-6	Cross-Sectional Schematic of Compost Pile with Roof, Badger Army Ammunition Plant	3-11
3-7	Concentration of Nitrocellulose in Compost Pile 2	3-12
3-8	Concentration of Nitrocellulose in Compost Pile 3	3-13
3-9	Concentration of Nitrocellulose in Compost Pile 4	3-14

LIST OF TABLES

<u>Table</u>	<u>Title</u>	<u>Page</u>
1-1	General Characteristics of NC Fines Waste	1-3
4-1	Comparative Matrix of Selected Technologies	4-2



EXECUTIVE SUMMARY

The U.S. Army Environmental Center (USAEC) is evaluating treatment options for residual solids, or fines, derived from the production of nitrocellulose (NC), a highly substituted cellulose fiber used as a propellant in munitions and rocket motors. The material to be treated consists of fine NC particles with a nitrogen content on the order of 13.8% and very low inorganic fraction.

Previous testing by USAEC has indicated that low levels of NC in soils can be treated by composting. In addition, USAEC has recently conducted reactivity testing to evaluate levels of NC that can be safely incorporated into a compost operation. Based upon these studies, USAEC is now evaluating the technical and logistical feasibility of NC fines composting. As part of this effort, this Technology Identification Report (TIR) reviews other technologies that have been investigated for the treatment and disposal of NC fines.

A computerized literature search was conducted to identify potentially applicable technologies for NC fines treatment. Criteria used in evaluating technologies included the availability of test data to support the effectiveness of the technology, the overall status of development of the technology, and potential cost-effectiveness of the technology.

Based upon this evaluation process, the treatment technologies most applicable to NC fines at the present time include thermal destruction (incineration or open burning), alkaline hydrolysis, supplemental fuel firing, and biological treatment by composting. Of these technologies, thermal destruction has been most extensively used in the past; however, this approach may come under tighter regulatory control in the future as a result of concern over nitrogen emissions and general disfavor of open burning methods. The principle of alkaline hydrolysis has been well known for a number of years, but this approach has not been fully developed in part because of uncertainties with respect to the reaction products. Both supplemental fuel firing and composting may have promise based upon laboratory pilot testing to date, but further development is required for either approach. Similar to thermal destruction, supplemental fuel approaches may also need to address nitrogen air emission



requirements. For composting, the technical and regulatory requirements for disposal of the final residue must be evaluated.



SECTION 1 INTRODUCTION

1.1 BACKGROUND

The manufacture and handling of explosives and propellants at Army Ammunition Plants (AAPs) and Army Depots (ADs) have resulted in the production of various types of wastes that require appropriate treatment and management to minimize and control their environmental impact. The U.S. Army Environmental Center (USAEC), formerly the U.S. Army Toxic and Hazardous Materials Agency (USATHAMA), has responsibility for evaluating and developing cost-effective treatment technologies to meet the goals of the Army's environmental program.

One propellant waste for which USAEC is evaluating treatment options is the non-recoverable solid materials, or fines, derived from the production of nitrocellulose (NC). The solids to be treated result from both current and historical NC production at Radford Army Ammunition Plant (RAAP) and historical NC production at Badger Army Ammunition Plant (BAAP).

NC is a highly substituted cellulose fiber that is synthesized from cellulosic materials such as wood pulp or cotton, and used as a propellant in munitions and rocket motors. NC is produced by nitrating the cellulosic material with nitric and sulfuric acids and is refined by additional processes [1,2]. The degree of nitration can be controlled by adjusting acid strength and processing conditions. As a result, NC can contain from 11.11% nitrogen (cellulose dinitrate) to a theoretical level of 14.14% nitrogen (cellulose trinitrate). Munition NC typically contains 13.8% nitrogen, while nitrogen levels in industrial NC (used in inks, coatings, film, and adhesives) are lower [1,2,3,4].

Manufacture of NC results in the production of NC solids, which cannot be completely recovered or reused (NC fines). The Army is investigating options to maximize both the recovery of NC fines and the recycling of the NC fines into useful product [5].

USAEC is considering composting to convert and reuse NC fines into soil amendment material. USAEC previously conducted a pilot test for composting of soils containing low levels of NC [6]. In addition, USAEC has recently conducted reactivity testing to evaluate whether high levels of NC fines can be handled safely in a composting matrix [7]. Based upon these previous studies, USAEC is now evaluating the technical and logistical feasibility of NC fines composting. The first phase of this effort, presented in this report, is the identification and review of available alternative technologies that may be used to treat NC fines. A review and comparison of these technologies, as well as a description of the literature search that resulted in the identification of these technologies, is included in this Technology Identification Report (TIR).

1.2 CHARACTERISTICS OF NITROCELLULOSE FINES

A preliminary data search on the characteristics of NC fines was conducted as part of the USACE reactivity testing project [7]. Sources included published literature [1,4,5] and information provided by RAAP [7,8]. Available data derived from these sources are summarized in Table 1-1. In interpreting these data, it should be recognized that specific analyses for the actual NC fines production solids as they would be received for treatment are generally not available, simply because there has been little previous need for such characterization.

The data in Table 1-1 reflect published characteristics of the NC product itself, as well as approximations based upon RAAP records. For example, the shipping weight for NC products has been used to estimate the bulk density of NC fines sludge [8]. With respect to moisture level and bulk density, it should also be recognized that NC fines in settling pits may exhibit very high moisture levels. Dewatering of this slurry to minimal moisture levels required by safety criteria, however, would most likely be accomplished before treatment. It is also possible that a certain amount of lagoon soil would be entrained in the NC fines if excavation is used to remove the material from the lagoons.

**Table 1-1
General Characteristics of NC Fines Waste**

Property (units)	Value or Range	Comment
Source	Cellulose (wood pulp or cotton linters), nitrated with HNO ₃ /H ₂ SO ₄	Various sources, levels of nitration and other particulars depending upon product end use.
Nitrogen content (as N) in typical RAAP fines	12.4-13.05%	Pure products range from 11.11 to 14.14%
Moisture content, by weight, minimum	25-30%	Minimum allowable based upon safety/handling considerations. Fines in lagoons are liquid (pumpable). Can be pressed to ±25 to 30% safely.
Bulk density	22-24 lb/ft ³	Based upon verbal report on product shipping data.
Particle size distribution	<100μ	Preliminary information.
Inert (ash) content	0.4-1.0%	Estimated values. Ash content in product typically no more than 0.4%; NaCO ₃ added during processing at 0.5%.
Melting point	>135 °C	
Decomposition rate in water at 50 °C (percent available HNO ₃ liberated per hour)	1.11 X 10 ³	
Solubility Water Alcohol, ethers, esters	"insoluble" high, variable	Solubility varies with solvent and type of NC, but water solubility is low.

SECTION 2
LITERATURE SEARCH

Section 2 contains a listing of databases and keywords used to conduct the literature search for available technologies. Preliminary screening criteria and the selected technologies, as well as regulations pertaining to NC, are also included.

2.1 METHODOLOGY

In order to evaluate the currently available technologies for NC fines treatment, a search of the research and technical literature was conducted. To ensure a thorough, complete search, the following computerized databases were searched:

- Energy, Science, and Technology (U.S. Department of Energy).
- Scisearch (Institute for Scientific Information).
- Engineered Materials Abstract (ASM International).
- PASCAL (CNRS/INIST, Institute of Information, France).
- CA Search (Chemical Abstracts Service).
- Ei Compendex Plus (Ei Engineering Information, Inc.).
- NTIS Database (National Technical Information Service).

The following keywords were initially searched:

- Nitrocellulose.
- Nitrocellulose and regulations, or remediation, or technologies, or degradation, or disposal, or recovery.

In total, 37 articles were found using these keywords; however, articles evaluating the available technologies were limited, so the search was expanded using these additional keywords:

- Propellant.
- Contamination.
- Waste treatment.

- Waste disposal.
- Biological treatment.

This search resulted in 27 additional articles. Of the total of 64 articles, 19 were obtained and reviewed. The remaining 45 articles were considered to be nonapplicable to this evaluation based upon the capsule summaries provided in the literature search. No chronological limit was placed on the selection process, and an additional eight sources, obtained during previous NC composting work [6,7], were also reviewed. The results of the literature review are presented in Sections 4 and 5.

2.2 REGULATORY STATUS

The management of NC fines may be affected by its classification under environmental regulatory programs. Key distinctions would include whether the NC fines are considered solid wastes at the point of management and treatment and, if so, whether they are hazardous wastes under the Resource Conservation and Recovery Act (RCRA).

NC fines, which settle in the pits at the production facility, are potentially reusable in the production of certain propellant products. NC fines can be recycled and blended into those propellant products, at defined ratios, during the manufacturing process. In such cases the NC fines are not discarded and would not be considered wastes. The ability to use all of the NC fines produced would be determined by the demand for the particular products in which they are used, and by the acceptable ratio of their incorporation into those products. It is possible that, at least intermittently, some quantities of excess NC fines may have to be managed under conditions that would result in their being classified as wastes.

Based upon a preliminary review of RCRA waste classifications, it appears that, depending upon such factors as total NC level and moisture content, NC fines wastes, if any, could be reactive and therefore could be considered as Characteristic Wastes as a result of reactivity (Waste Code D003). In such a case, management, storage, and treatment of the waste NC fines would have to comply with RCRA requirements and be conducted under a RCRA permit. Specific requirements would depend on the type of system (i.e., treatment process)

used. In general, however, those specific standards would require provisions for control of waste migration during operation and for closure of the management unit at the end of its operating life.

Under the provisions of RCRA, characteristic hazardous wastes, following treatment such that they no longer exhibit the characteristic for which listed, can be considered no longer hazardous wastes and subsequently managed as solid (nonhazardous) wastes. Therefore, any waste NC fines would require treatment to ameliorate their reactivity. This would presumably be achieved by physical, chemical, thermal, or biological processes that destroy the energetic properties of NC.

Concurrently with the literature review process, regulatory agencies, including the Virginia Department of Environmental Quality (DEQ), the Wisconsin Department of Natural Resources (DNR), and the U.S. Environmental Protection Agency (EPA), were contacted in order to obtain information regarding the potential regulation of NC treatment methods and treated residue disposition. Wisconsin DNR and Virginia DEQ were contacted because these are the applicable state agencies for BAAP and RAAP, which are currently identified as having NC fines to be managed. Facility names, however, were not identified to the agencies during these contacts.

Representatives from both the Virginia DEQ and the Wisconsin DNR directed the search to specific sections within their respective waste regulations. These sections were searched using a personal computer and several keywords that pertained to the objective, namely:

- Composting
- Waste piles
- Land treatment
- Land application
- Land spreading

The Virginia regulation search resulted in information on how to design, operate, and close a waste pile system. It also listed the requirements for land treatment of waste. Both

sections had special requirements listed for ignitable or reactive wastes that must also be evaluated.

Wisconsin regulations, when examined, turned up no information specifically applicable to the treatment of NC. Basic permitting procedures for waste treatment units were listed, but no specific design, operating, or closure requirements were included. In areas in which state requirements are not definitive, guidance can be obtained from federal RCRA requirements.

In as much as these state regulations did not specifically address NC, they are not directly applicable to this TIR. Their requirements will be considered in the evaluation of compost disposal options under subsequent tasks.

2.3 TECHNOLOGY SCREENING CRITERIA

In evaluating the different technologies presented in this report, several criteria were developed to analyze the treatment alternatives. One criterion set by the USAEC was that treatment options without technical data supporting their applicability to NC would not be considered viable for purposes of this report. Therefore, such technologies are not included in this TIR. In evaluating of the technologies studied, further questions to be asked include:

- Is NC rendered nonhazardous by the technology?
- To what concentration is NC reduced?
- Is the technology ready for practical application?
- Are substantial data available to support performance?
- What disposal requirements are needed for process products?
- Is the technology economically feasible?

The technologies selected for evaluation are discussed in Section 3. The result of this screening process is summarized, in matrix form, in Section 4 of this report.

2.4 IDENTIFICATION OF CANDIDATE TECHNOLOGIES

Based upon review of the literature and preliminary analysis of applicability, the processes appearing most applicable to RAAP and BAAP's NC fines were:

- Thermal destruction by incineration or open burning/open detonation.
- Chemical treatment by alkaline hydrolysis.
- Destruction by supplemental fuels firing.
- Biological treatment by composting.

The list was compiled from an original list of the 14 possible techniques listed below:

- Open burning/open detonation.
- Biological (composting).
- Supplemental fuels firing.
- Chemical treatment (acid or alkaline hydrolysis).
- Wet air oxidation.
- Microwave plasma.
- High energy electrons.
- Gamma radiation.
- UV ozone.
- UV peroxide.
- X-ray.
- Pulsed laser.
- Incineration.
- Molton salt incineration.

As a result of a stipulation set by USAEC, any process that was a theoretical or paper study was disregarded. This narrowed the list significantly. The technologies selected all have at least laboratory studies performed specifically on the NC fines or wastes that occur at RAAP and/or BAAP. Therefore, the study results are assumed to be applicable. An explanation and review of testing completed on the selected technologies is included in Section 3.

SECTION 3**REVIEW OF CANDIDATE TECHNOLOGIES**

Section 3 outlines each of the selected technologies, i.e., thermal destruction, chemical treatment, supplemental fuel, and composting, and includes the information compiled from the reviewed literature.

3.1 THERMAL TREATMENT**3.1.1 Incineration**

Incineration would destroy NC fines by thermal oxidation at high temperatures. A variety of incinerator configurations are conventionally available. In a previous study conducted by USATHAMA, fluidized bed incineration was concluded to be the most viable incineration process to destroy NC fines safely and effectively as compared to various direct-fired or other indirect combustion systems [11]. Advantages attributed to the fluidized bed process included its ability to process high viscosity sludges and its indirect firing.

A process flow schematic is shown in Figure 3-1. A constant 10% NC slurry would be introduced to the combustion chamber, which is preheated by No. 2 fuel oil. The NC concentration in the feed is monitored by a density meter. Maintaining the desired feed concentration would require a pretreatment of the slurry because typical storage moisture content of NC is 25% to 30% (see Table 1-1). The emissions from the combustion process passed through a cyclone to a spray tower in which water is used to decrease the temperature of the gases from a temperature of 1,800 °F to 1,000 °F. A series of heat exchangers would be used, and the recovered hot air would be available for use. Process gas would then be filtered for particulates in the bag house. The filtered gas would be sent to the stack for release into the atmosphere [11]. Minimal ash is collected from the process, and it would presumably be sent to a landfill for disposal. The overall process would have a projected minimum destruction and removal efficiency of 99.99% [11].

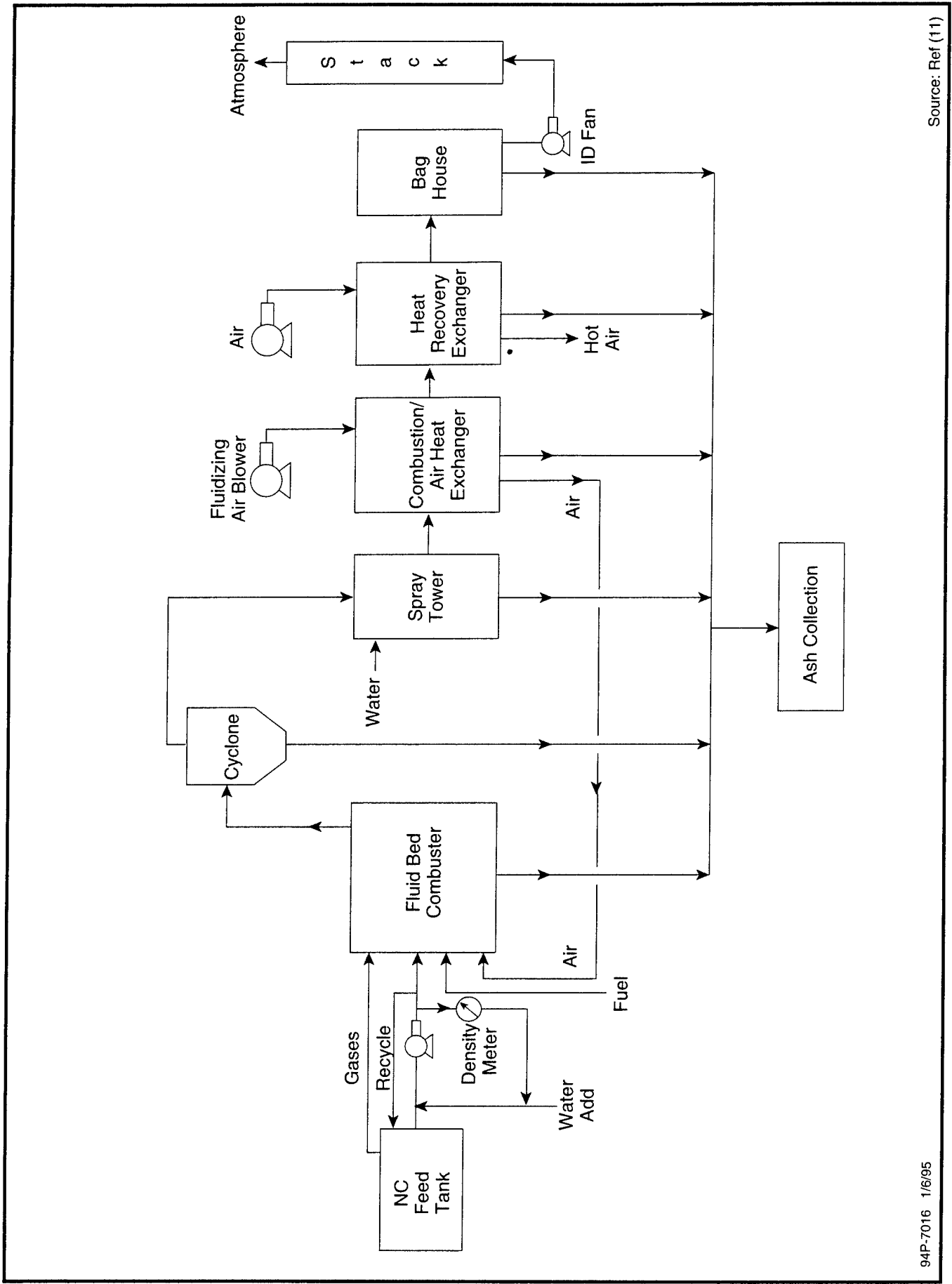

Source: Ref (11)

FIGURE 3-1 PROCESS SCHEMATIC FOR FLUIDIZED BED INCINERATION

94P-7016 1/6/95

One drawback of incineration is the high costs. In 1987, capital costs were estimated at \$2.8 million. Daily operational costs were estimated at \$7,611 [11]. As indicated above, process residuals from incineration would include ash/particulates and the exhaust gas. The relatively high nitrogen content of NC (up to 14.14% by weight) may make nitrogen emissions from the incinerator a source of future concern from the standpoint of air emissions permitting and control technologies.

3.1.2 Open Burning/Open Detonation

Open burning/open detonation(OB/OD) consists of the combustion of materials under relatively unconfined conditions. While there may be concerns about the efficiency of, and potential emissions from, OB/OD operations, there are classes of materials such as explosives and munitions for which no safe and practical destruction alternatives have been available, because of their reactivity. OB/OD has conventionally been used for propellants containing NC and is a relatively inexpensive process.

In an OB/OD process conducted by DuPont for a private explosives manufacturing facility located in New Jersey, the burn unit was prepared with a layer of dunnage followed by a 2-inch layer of NC to be destroyed [12]. Time was allowed for drainage of the excess moisture from the NC. A fuel (such as kerosene) was supplied, and the pile was electrically ignited remotely. The ash from the process was then disposed of at an off-site landfill. The total cost of the project was \$2.4 million to process 55,000 pounds of NC [12].

One major potential problem with open burning is the permitting requirements. OB/OD operations for hazardous wastes are generally considered under Resources Conservation and Recovery Act (RCRA) Subtitle C to be in the Miscellaneous Units category (40 CFR 264 Subpart X) for purposes of permitting. It should be noted that OB/OD is coming under closer scrutiny by regulatory agencies, and there is resistance to permitting OB/OD operations unless no alternative disposal method is available. On the DuPont project noted above, the permits proved not be a major problem. All of the necessary permits were obtained in 2 months, although process limitations were included within the permits [12].

3.2 ALKALINE HYDROLYSIS

Alkaline hydrolysis is the procedure in which an alkaline reagent is added to a NC slurry stream and is maintained at elevated temperature over a given retention time. During this process, the carbon structure of NC is attacked and oxidized, and the nitrogen is released. The whitish particulate NC is converted to a coffee-colored soluble product containing the denitrified and degraded cellulose polymer [10].

Alkaline hydrolysis was first identified as a method for degrading NC during the early twentieth century [10]; however, a variety of uncertainties were associated with this process. These include the incomplete removal of nitrogen, the incomplete conversion of the carbon backbone to CO₂, the unknown nature of the reaction products that resulted, and the possible formation of cyanide and ammonia as reduction products. The apparently incomplete degradation of NC in alkaline hydrolysis results in the requirement for further treatment and/or disposal of the hydrolysis process residue/reaction products. Biological treatment has been proposed to handle the liquid product stream from alkaline hydrolysis. This TIR focuses upon several recent studies that have been conducted under renewed interest in this technology.

Several alkaline reagents, e.g., potassium hydroxide (KOH), sodium hydroxide (NaOH), and calcium hydroxide (Ca(OH)₂), at different temperatures and concentrations were tested independently by Alleman, et al., to see which conditions yielded the best results [10]. Five to 10% concentrations of either KOH or NaOH at 50 °C over a retention time of 6 to 8 hours produced the greatest hydrolysis of NC. A maximum of approximately 90% of the total nitrogen (nitrite- and nitrate-nitrogen) was released during the process. Graphical presentation of the total nitrogen released over time for each test case are reproduced in Figures 3-2, 3-3, and 3-4.

Preliminary biodegradation tests conducted on the hydrolysis products, based upon oxygen consumption measurements, gave some indication that the products were degradable; however, the authors felt that oxidation of the residual nitrate to nitrite, rather than

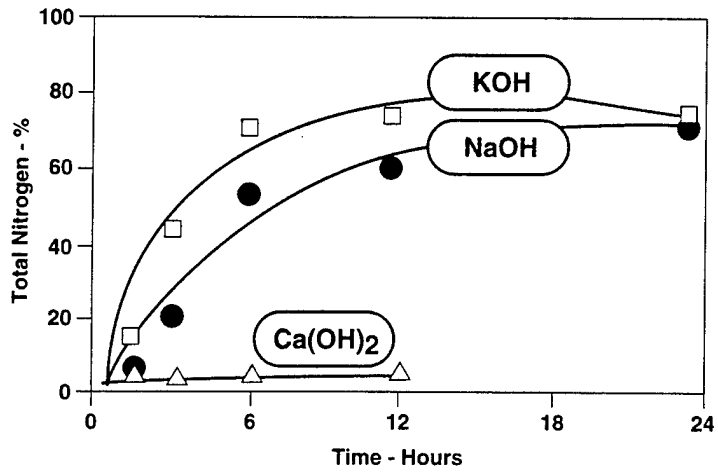

Figure 3-2 Chronological NO_x-N Yield Relative to Alkali Form

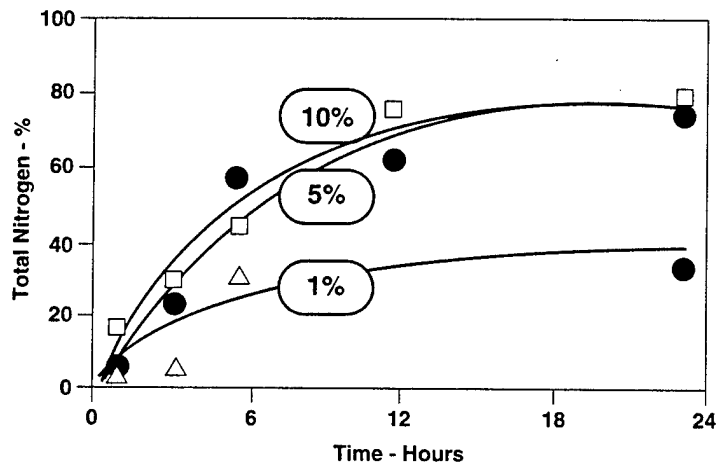

Figure 3-3 Chronological NO_x-N Yield Relative to Alkali Dose

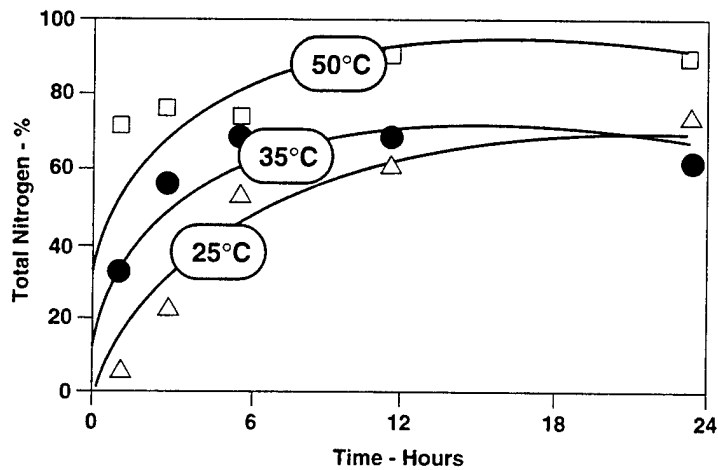

Figure 3-4 Chronological NO_x-N Yield Relative to Hydrolysis Temperature

oxidation of carbonaceous products, could account for a large portion of the apparent oxygen demand.

Experiments conducted by Arthur D. Little, Inc., showed that, at 5% caustic, 90 °C, and a retention time of 3 hours, NC would be rendered suitable for biodegradation [11]. The process tested is presented schematically in Figure 3-5. This is a two-stage process in which 10 or 25% NC solids sludge is added to a caustic solution and kept in a predigestion reactor for 1 hour to raise the temperature to 65 °C by the use of low pressure steam. The slurry is then passed through a jet cooker where the temperature is raised through direct steam injection to 95 °C. The serpentine reactor provides the necessary retention time of 3 hours. In a paper study conducted by the Atlantic Research Corporation (ARC), the hydrolysis process that was evaluated did not contain the predigestion reactor. Instead, it consisted of simply a mixing bin, a reactor, and a heat-exchanger, The rate at which the slurry was fed would determine the retention time of the process [20].

The product of the hydrolysis treatment needs to be neutralized and processed biologically before it is ready for disposal. This could possibly be accomplished in a conventional biological wastewater treatment plant. Typical additional BOD₅ loading to the biological treatment facility from the hydrolysis process would be approximately 1,700 mg/L [11]. In evaluating alkaline hydrolysis for use at RAAP, it was concluded that RAAP's existing biological wastewater treatment facility would need to be expanded in order to accommodate the additional BOD₅ load, but the NC digest would be beneficial to the nitrate-poor system at RAAP and, therefore, denitrification steps would be unnecessary [11].

Exclusive of any neutralizing or biological post-treatment, capital costs for the alkaline digestion process were estimated in 1987 dollars at \$349,651 with daily costs at \$958 [11].

In contrast to these tests using potassium or sodium hydroxide, studies were conducted by Bissett and Levasseur to see if NC could be treated with ammonium hydroxide (NH₄OH) to produce ammonium nitrate and nitrite, both of which are good fertilizers. Therefore, if

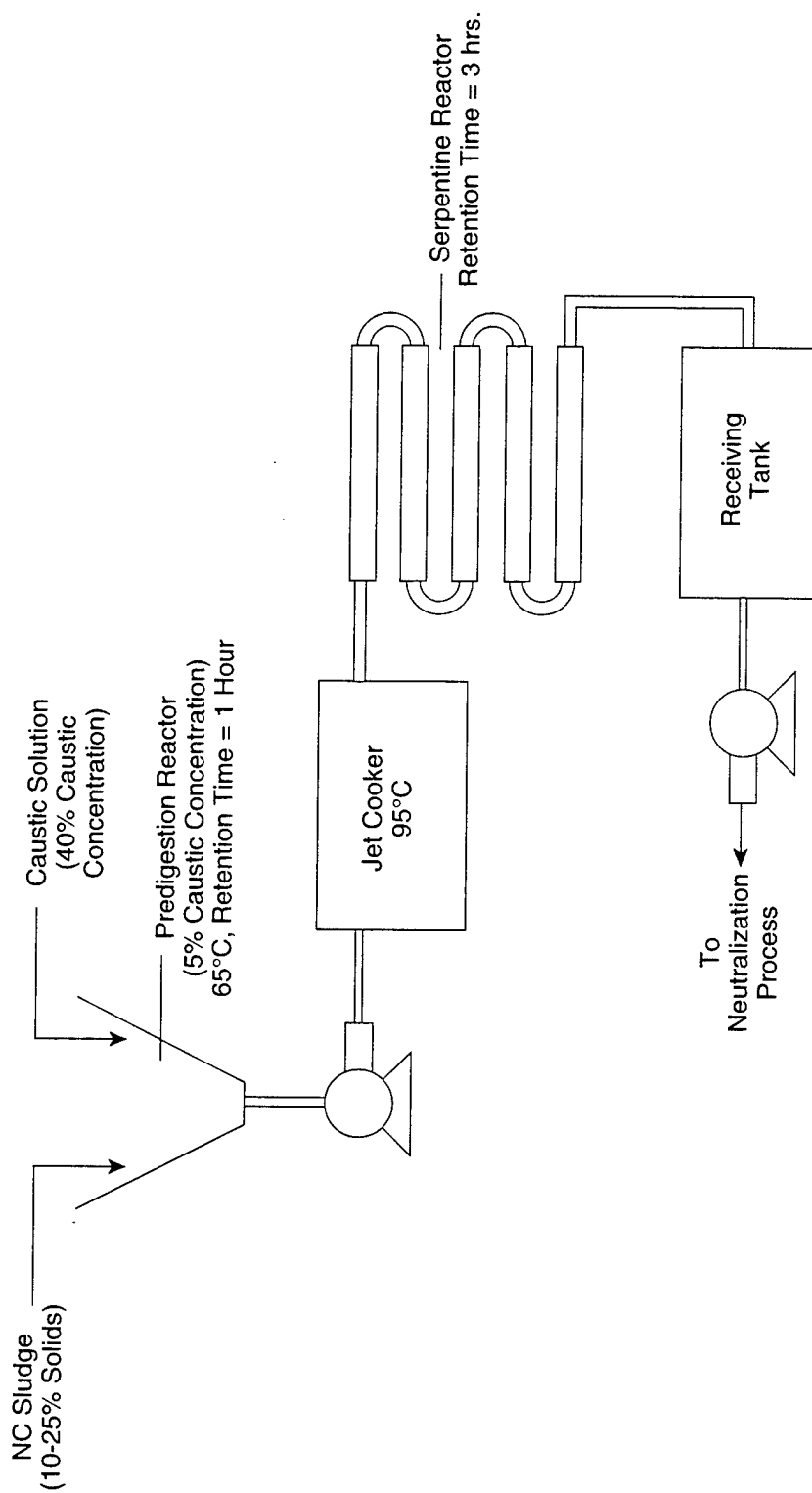

FIGURE 3-5 PROCESS SCHEMATIC FOR ALKALINE HYDROLYSIS

successful, it is possible that the processed NC could be applied to land, as a fertilizer, assuming it is proven to be nontoxic to plants and animals.

Two types of systems (open and closed) were tested. Using a 5% NC slurry suspended in a 10% NH_4OH , in an open system at an elevated temperature of 75 °C, 8 hours were required for nearly complete degradation. NH_4OH was lost through volatilization at the increased temperature, possibly interfering with the extent of the reaction. The same analysis was completed in a closed vessel system. Under these conditions, the time required for a complete reaction was reduced to 4 hours [15].

The small quantities of residual NC fines that remain in the product solution are insoluble and could be filtered for reprocessing [15]. The solution was analyzed by infrared spectroscopy, which produced bands indicating both ammonium nitrite and nitrate were present, along with various salts and organic acids [15]. If a suitable application were not found, this solution would require further treatment and disposal. As noted previously, the intended use of this product would be as a fertilizer. This study did not include demonstration of its suitability for that use. The cost, in 1994 dollars, for the NH_4OH needed to degrade 1 ton of NC is \$95. No other information was provided in equipment or operating requirements for large scale application. Therefore, a complete cost estimate for this process is not available.

As compared to destruction technologies (i.e., incineration or open burning), however, this approach (and possibly other hydrolysis approaches) offers some potential economic recovery if the resulting product is marketable or can be used by the Army to replace currently used fertilizers.

3.3 SUPPLEMENTAL FUEL

Recent research and testing have been conducted on the potential use of propellant compounds as supplemental fuels in firing, for example, boilers for power generation. In this process, the propellant compounds would be added to, and/or mixed with, the

conventional boiler fuel (such as fuel oil). The high energy content of the energetic component would thus be recovered in the form of useful heat energy.

Laboratory testing has been conducted by the Tennessee Valley Authority (TVA) for USAEC to evaluate the applicability of NC, nitroguanidine, or AA2 (a double-based propellant made from pyroxylin and nitroglycerin) propellants as an additive to No. 2 fuel oil [13,14]. The first study analyzed the properties of both the propellants and the resulting supplemental fuel mixtures, as well as the compatibility with, and performance in, existing combustion equipment. TVA's report also examined the economic feasibility of the supplemental fuels method. Results from the study showed that because it was insoluble, NC added to the viscosity of the fuel oil. The maximum level of NC that could be accommodated in a fuel oil burner on the basis of viscosity was considered to be 10% NC by weight, even with modifications to the burner.

With this upper concentration limit, testing conducted for the TVA study indicated that the NC fuel oil mixture was combustible, and therefore that use of the NC fuel oil mixture in a burner was feasible. Testing included measurements of flash points, heats of combustion, and emissions. Direct testing of the mixture in a burner was not conducted. Major emissions to be expected from this process included CO₂, H₂O, and smaller amounts of nitrogen oxides (NO_x), ammonia (NH₃), hydrogen (H₂), nitrogen (N₂), carbon monoxide (CO), and lead oxides.

The technical and economic analysis indicated a projected cost for supplemental fuel firing of 10% propellant-fuel oil slurries at \$350 per ton of propellant in 1990 dollars. This represents the incremental cost of the combustion system to destroy the propellants, and includes the potential fuel cost savings obtained by substituting the propellant for a portion of the fuel oil, to provide an equal total heating value. The additional net cost for the supplemental fuel operation is a result of equipment and labor costs for the feed preparation steps.

The second TVA study investigated the capacity of the test fuel to propagate a detonation. Evaluation of both static and dynamic conditions were conducted through the Zero Gap Test, and the results showed that at the given weight concentrations of the propellants, the supplemental fuels could be processed without the possibility of detonation [14].

3.4 BIOLOGICAL TREATMENT BY COMPOSTING

Composting, historically, has been used as a treatment process to biodegrade high organic materials, such as biosolids from wastewater treatment plants, municipal solid wastes (MSW), and agricultural or yard wastes. Typical objectives of conventional composting include:

- Stabilization of organic matter.
- Reduction in the waste volume.
- Reduction in moisture content.
- Destruction of pathogenic microorganisms.

By contrast, the purpose of composting hazardous materials is the rapid removal or destruction of the specific constituents or properties of the material that render it hazardous. Past work conducted at BAAP for composting NC-contaminated soils using the aerated static pile method [6]. A schematic of the system used by BAAP is shown in Figure 3-6. Given initial extractable NC concentrations of 3,039, 7,907, and 13,086 mg/kg, after 151 days for the first case, and 112 days of composting for the later two cases, extractable concentrations dropped to 54, 30, and 16 mg/kg, respectively. This results in mean percent reductions of 98%, 99.6%, and 99.9% [6]. These results are shown graphically in Figures 3-7, 3-8, and 3-9, respectively.

In addition to demonstrating that NC-contaminated soils can be composted, the BAAP pilot study provided preliminary evidence that NC can be degraded at high concentrations. Small portions of the compost matrix were spiked with pure NC at various concentrations up to 80% by weight, placed into porous nylon bags and incubated within the compost. Reduction in NC levels were observed at concentrations up to 60% NC by weight. This suggests that

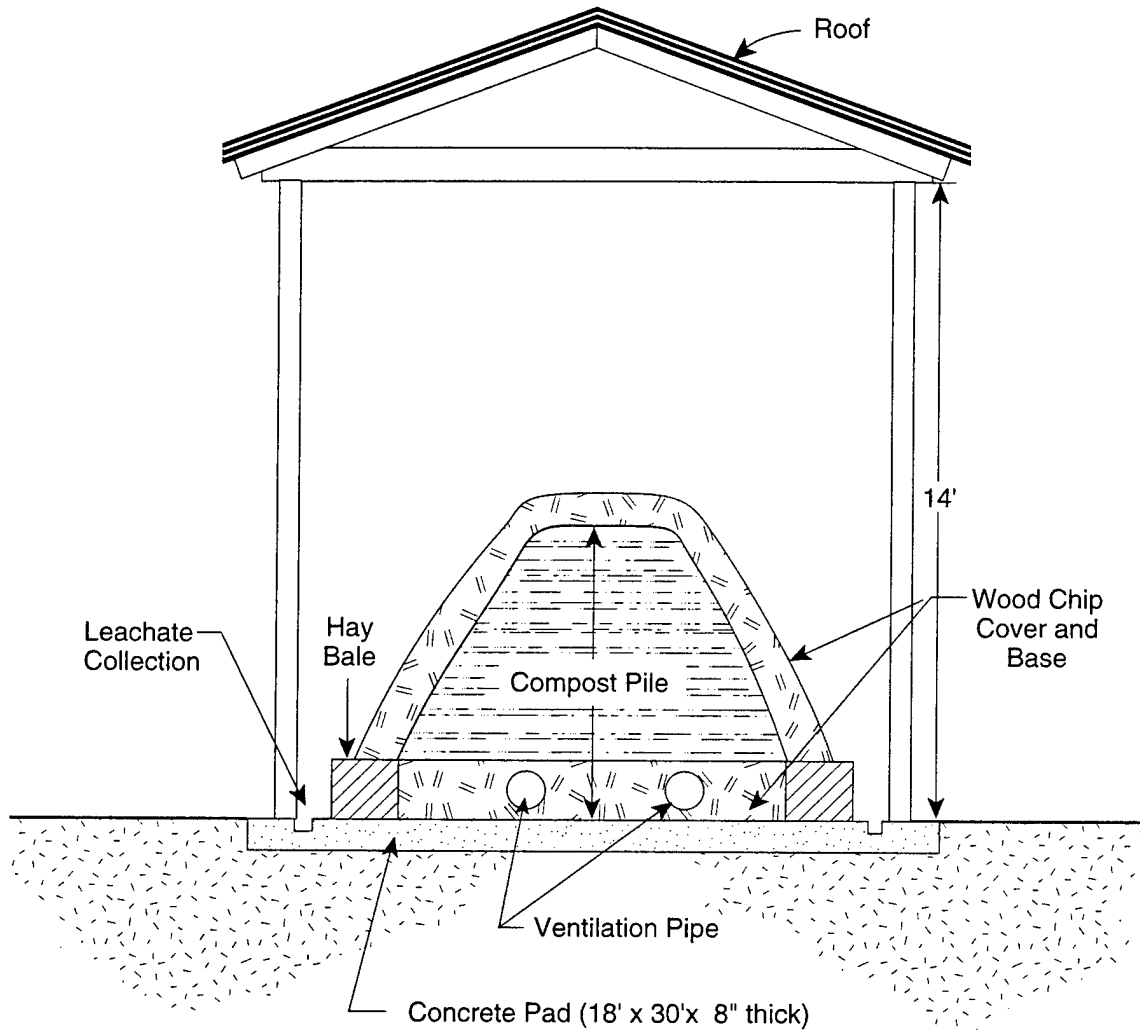

NOTE: Schematic only, not to scale.

FIGURE 3-6 CROSS-SECTIONAL SCHEMATIC OF COMPOST PILE WITH ROOF, BADGER ARMY AMMUNITION PLANT

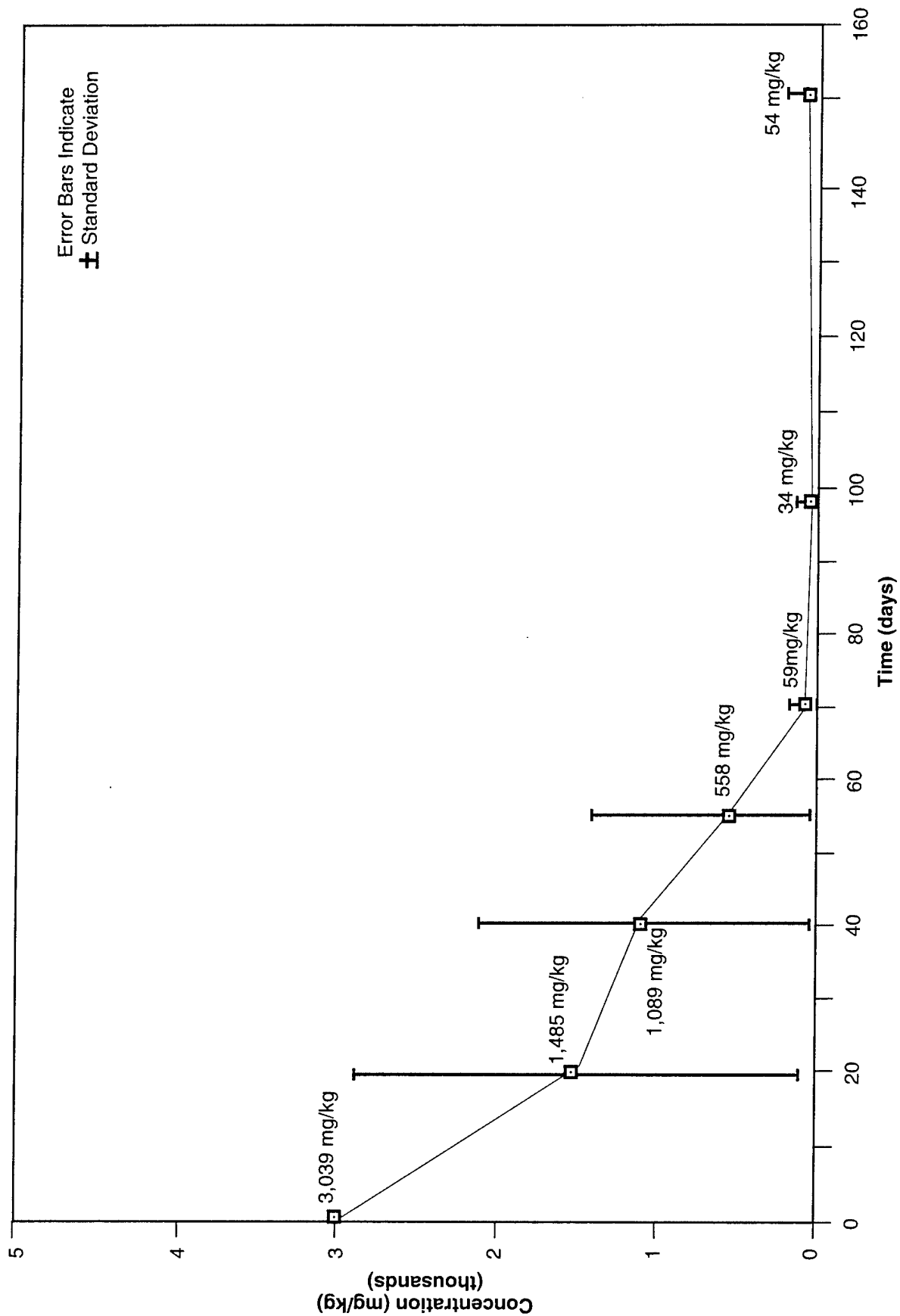

94P-7018 1/6/95

SOURCE: Ref (6)

**FIGURE 3-7 CONCENTRATION OF NITROCELLULOSE
IN COMPOST PILE 2**

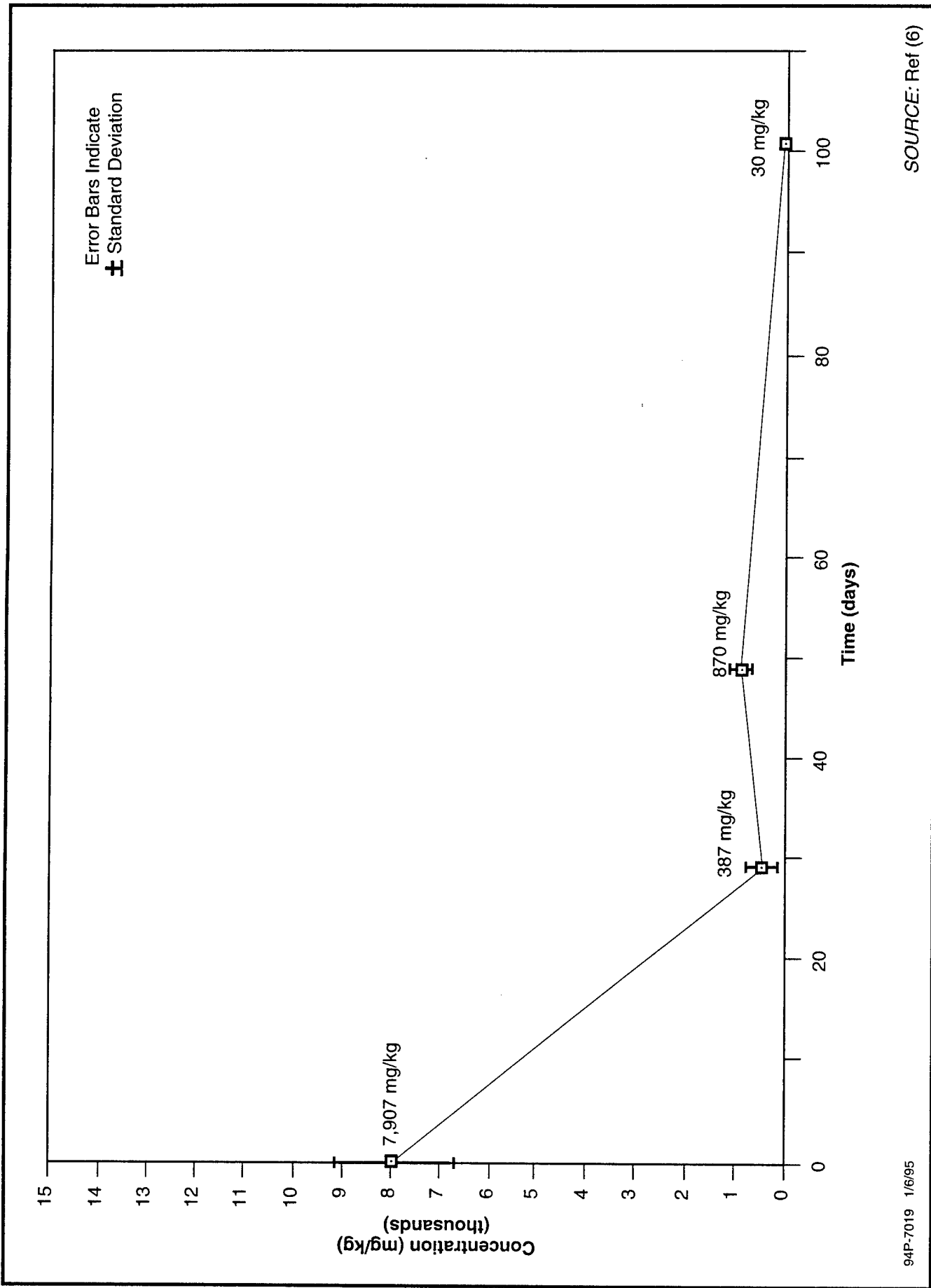
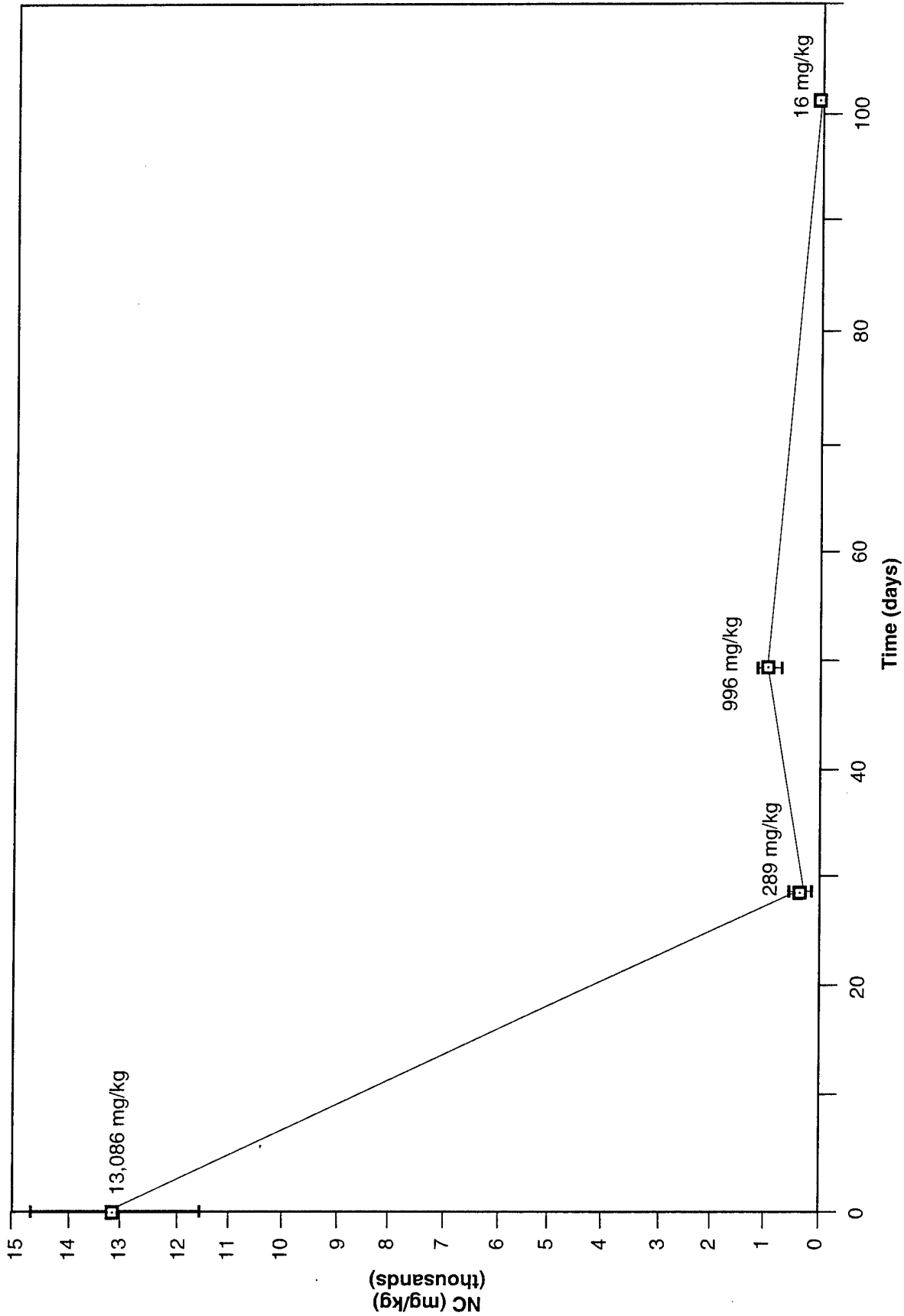

FIGURE 3-8 CONCENTRATION OF NITROCELLULOSE IN COMPOST PILE 3



94P-7020 1/6/95

SOURCE: Ref (6)

FIGURE 3-9 CONCENTRATION OF NITROCELLULOSE IN COMPOST PILE 4

high concentrations of NC can be treated when incubated under composting conditions. It has not as yet been established, however, that a high NC compost mixture will achieve and sustain composting conditions by itself [7].

TVA evaluated the economic feasibility of NC fines composting, using static pile or in-vessel systems [9]. Three representative in-vessel systems were evaluated: a Metcalf & Eddy (Paygrow) process in Baltimore, Maryland; a Fairfield process in Plattsburg, New York; and an Ebara process in Seven Springs, Pennsylvania. One aerated static pile system was also evaluated. All four systems evaluated by TVA had a capacity of 6,000 pounds per day wet basis (no exact moisture content was given) of the NC fines.

Results from the economic feasibility analysis showed that, in 1991 dollars, the capital costs of the static pile system would be approximately \$7.7 million, and the operational cost would be approximately \$455 per day. This compares to a range for capital cost of \$5.8 to \$12.2 million, and \$471 to \$772 per day for operational costs of the three in-vessel systems.

The study concluded that, based on the economic analysis, further testing to determine the lowest C:N ratio, effect of temperature, and proportions of amendments was warranted on both a laboratory and pilot-scale basis [9].

USAEC has recently conducted testing to determine whether high levels of NC fines can safely be handled within a composting matrix. As a propellant compound, pure NC poses potential reactivity problems under certain storage and handling situations. As noted in Subsection 1.2 and Table 1-1, pure nitrocellulose is always handled wet (>25% moisture) during production storage and shipment to control its reactivity. The USAEC reactivity testing program consisted of subjecting defined mixtures of NC fines/compost to standardized reactivity test procedures, to determine the ranges of NC levels and moisture contents that could be considered nonreactive in a compost matrix. Data from this study may determine not only the initial compost mixture characteristics, but may also establish safe operating ranges for moisture during the composting operation. Preliminary test data

suggest that at certain NC levels and moisture levels, NC fines compost will not be reactive using standard reactivity test procedures.

While previous pilot tests indicate that NC levels can be substantially reduced by composting, it is not known definitely whether the NC's cellulose backbone is degraded or simply denitrated. Although substituted cellulose compounds are generally considered resistant to direct biological attack [18], preliminary bench-scale composting tests conducted by USAEC indicated relatively high CO₂ evolution, suggestive of complete degradation [19]. Even if only denitration is achieved, the hazardous (reactive) nature of NC may be addressed, leaving a solid residue requiring further management.

The nonhazardous compost product derived from the composting process could be landfilled or land-applied. The use of conventional (i.e., agricultural or sludge) compost as a soil amendment is well known. It has value as a soil conditioner to improve texture and as a source of nutrients. Assuming that finished NC fines compost consists of the denitrated cellulose fragments in an agricultural byproduct matrix, it is possible that it would also be useful as a soil amendment. Although the phytotoxicity of NC does not appear to have been specifically tested, NC is not considered toxic to animals [17]. Furthermore, preliminary work has been conducted on the direct application of NC to soils for plant growth. One study showed up to a 68% mass increase in sorghum yield when single-based NC was applied [16]. Therefore, it appears likely that finished NC fines compost would not pose problems and may be beneficial when used as a soil amendment.

Although these preliminary evaluations suggest that land application of finished NC fines compost may be technically feasible, regulatory policies will need further evaluation in the subsequent Facility Compost Report analyses. In particular, the classification of NC fines and any resulting constraints on the composting and compost disposal operation must be considered.



SECTION 4

COMPARATIVE EVALUATION OF TECHNOLOGIES

In order to provide USAEC with a comparison of the technologies presented, the following criteria were applied to each treatment process:

- Is a nonhazardous product produced? (Yes/No)
- What is the percent of reduction of the NC concentration? (Range of percent)
- What testing scale has been completed on the process? (Bench scale/pilot scale/full scale)
- Are there data to support the conclusion of the studies? (Yes/No)
- What are the disposal options of the process products? (List of techniques)
- Are there economic data available for the process? (Yes/No)

The results of this analysis are summarized in matrix form in Table 4-1.

**Table 4-1
Comparative Matrix of Selected Technologies**

Technology	Percent Reduction of NC	Scale	Data Available	Products			Economic Data Available
				Type	Non-Hazardous	Disposal	
Composting	97.86% - 99.59%	Pilot	Yes	solid	Yes	landfill; land application reclamation	No for fines; Yes for contaminated soil
Alkaline Hydrolysis	up to 100%	Bench	Yes	liquid	Yes	neutralization biodegradation	Yes *
Incineration	99.99%	Full	Yes	solid	Yes	landfill	Yes *
OB/OD	N/A	Full	Yes	solid	Yes	landfill	Yes *
Supplemental Fuels	N/A	Bench	Yes	liquid	Yes	combusted/incinerated with end products landfill	Yes *

*Economic data are available, but not enough for a fair comparison.



SECTION 5

CONCLUSIONS

Based on the results of this Technology Identification effort, the following technologies appear to have relatively near-term application to the management of NC fines:

- Thermal destruction (incineration or open burning).
- Alkaline hydrolysis.
- Supplemental fuel firing.
- Biological treatment by composting.

Of these technologies, thermal destruction appears to have had the widest past application for destruction of materials containing high levels of NC. Open burning has been practiced, for example, for destruction of propellants containing high NC fractions; however, open burning for all types of materials is coming under stricter control as agencies seek to limit its use to situations where no reasonable alternative exists. Incineration of NC may also face tighter emissions standards, particularly on nitrogen emissions. The use of NC fines as a supplemental fuel for power generation holds some promise for disposal, although air emissions considerations must still be addressed.

The potential use of alkaline hydrolysis has been known for many years; however, full scale development has been lacking. In part this may be a result of the uncertainties concerning the final reaction products, as well as (historically) lower restrictions on the direct discharge of NC fines. Because this process produces an aqueous wastestream containing both organics and nitrogen compounds, additional treatment will be required as part of the final management approach, and additional development of aqueous phase treatment may be necessary.

Pilot test data suggest that composting may be useful in treating NC. Additional work would be required to evaluate the degree of destruction obtained (i.e., mineralization of the cellulose structure versus simple denitration), particularly in light of literature suggesting that substituted cellulose molecules resist biological attack. As with alkaline hydrolysis,



however, destruction of the NC configuration, even if by simple denitration, may effectively deal with the reactivity characteristic for which NC is considered hazardous. In contrast to alkaline hydrolysis, which produces an aqueous product stream, composting would result in a nonhazardous solid residue (finished compost), which would require further management.



SECTION 6

REFERENCES

1. Shreve and Brink, 1977. *Chemical Process Industries*, Fourth Edition, Chapter 22, McGraw Hill.
2. U.S. Army, September 1984. *Military Explosives*, Department of the Army Technical Manual TM 9-1300-214.
3. Meyer, Rudolf, 1987. *Explosives*, Third Edition, VCH Publishers, New York.
4. Hercules Incorporated, 1979. *Nitrocellulose, Chemical and Physical Properties*.
5. Kim, B.Y., and J.K. Park, November 1993. "Comprehensive Evaluation and Development of Treatment technologies for Nitrocellulose Fines in Process Wastewater," *Nitrocellulose Fines Separation and Treatment Workshop Proceedings*, U.S. Army-Purdue University.
6. WESTON (Roy F. Weston, Inc.), November 1993. "Composting of Nitrocellulose-Contaminated Soils at Badger Army Ammunition Plant (BAAP) U.S. Army Environmental Center (USAEC)," *Nitrocellulose Fines Separation and Treatment Workshop Proceedings*, U.S. Army-Purdue University.
7. WESTON, August 1994. *Composting of Nitrocellulose Fines - Hazards Analysis Combined Test Plan*, Final Report, prepared for USAEC, Report No. SFIM-AEC-TSD.
8. Hercules Incorporated and Radford Army Ammunition Plant, November 1993. Personal communication.
9. TVA (Tennessee Valley Authority), March 1991. *Process and Economic Feasibility of Using Composting Technology To Treat Waste Nitrocellulose Fines*, Final Report, prepared for USATHAMA, Report No. CETHA-TE-CR-91012.
10. Alleman, J.E., November 1993. "Alkaline Hydrolysis of Munitions-Grade Nitrocellulose," *Nitrocellulose Fines Separation and Treatment Workshop Proceedings*, U.S. Army-Purdue University.
11. Arthur D. Little, Inc., September 1987. *Engineering/Cost Evaluation of Options for Removal/Disposal of NC Fines*, Final Report, prepared for USATHAMA, Report No. AMXTH-TE-CR-87134.
12. Glowacki, Mary L., and Mary A. Thomas, 1993. "Explosives Remediation and Treatment," in *Proceedings of the Hazardous and Industrial Waste Conference*, of the

Mid-Atlantic Industrial Waste Conference, Bucknell University, University of Cincinnati, University of Delaware, Drexel University, Howard University, et al.

13. TVA, September 1991. *Technical and Economic Analyses To Assess the Feasibility of Using Propellant - No. 2 Fuel Oil Slurries as a Supplemental Fuel*, Final Report, prepared for USATHAMA, Report No. CETHA-TS-CR-91046.
14. TVA, January 1992. *Zero Gap Propagation Testing of Propellant - No. 2 Fuel Oil Slurries*, Final Report, prepared for USATHAMA, Report No. CETHA-TS-CR-92005.
15. Bissett, Frank H., and Lenard A. Levasseur, September 1976. *Chemical Conversion of Nitrocellulose for Fertilizer*, Final Report, prepared for U.S. Army Natick Research and Development Command, Report No. NATICK/TR-77/027.
16. TPL, Inc., November 1993. "Reuse of Nitrocellulose (NC)-Based Gun Propellants for Agriculture Applications," *Nitrocellulose Fines Separation and Treatment Workshop Proceedings*, U.S. Army-Purdue University.
17. EPA (U.S. Environmental Protection Agency) Office of Drinking Water, September 1987. *Nitrocellulose Health Advisory*. Final Report, prepared for U.S. Army Medical Research and Development Command, Report No. PB90-273541.
18. Wendt, T.M., and A.M. Kaplan, 1976. "A Chemical-Biological Treatment Process for Cellulose Nitrate Disposal," *Journal WPCF*, 48, 4,660.
19. ARC (Atlantic Research Corporation), 1986. *Composting Explosives/Organics Contaminated Soils*, Final Technical Report, prepared for USATHAMA, Report No. AMXTH-TE-CR-86077.
20. ARC, April 1982. *Engineering and Development Support of General Decon Technology for the U.S. Army Installation Restoration Program*, Final Report, prepared for USATHAMA, Report No. DAAK11-80-C-0027.