



US Army Corps
of Engineers®
Engineer Research and
Development Center

Infrastructure Technology Research Program

Simple Methods Used to Estimate the Limit-State Axial Load Capacity of Spillway Invert Slabs

Ralph W. Strom and Robert M. Ebeling

August 2004

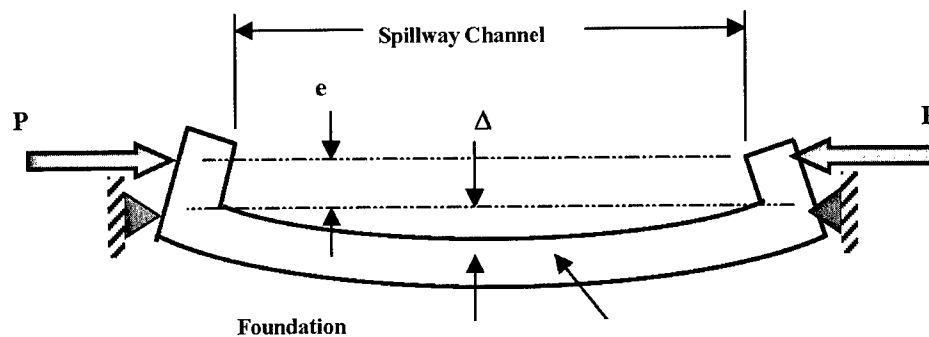
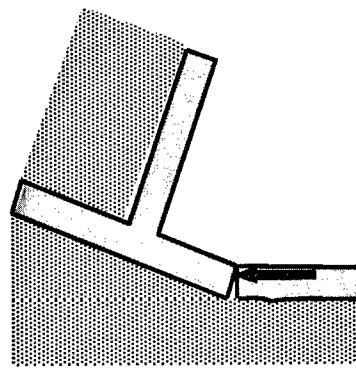

20041025 080

Simple Methods Used to Estimate the Limit-State Axial Load Capacity of Spillway Invert Slabs

Ralph W. Strom

9474 S.E. Carnaby Way
Portland, OR 97266

Robert M. Ebeling

Information Technology Laboratory
U.S. Army Engineer Research and Development Center
3909 Halls Ferry Road
Vicksburg, MS 39180-6199

Final report

Approved for public release; distribution is unlimited

Prepared for U.S. Army Corps of Engineers
Washington, DC 20314-1000

Under Work Unit 33215a

ABSTRACT: Invert spillway slabs provide an important contribution to the overall seismic stability of retaining walls, especially those earth-retaining L-walls and T-walls (sometimes referred to as cantilever retaining walls) that border spillway channels. Key to the seismic performance of spillway retaining walls is the stabilizing force that the channel invert slab exerts at the toe of the wall. The magnitude of this stabilizing force will depend on the limit state axial load capacity of the invert slab.

Invert slabs can be founded on earth or rock. Types of construction used by the Corps include an independent block plan and a continuous reinforcing plan. Invert slabs when loaded axially can exhibit either short column or long column behavior with the latter term referring to slabs whose axial capacity is reduced by second-order deformations (i.e., $P \cdot \Delta$ effects).

Slab capacity in terms of axial load-moment interaction is determined based on ultimate strength design principles and applied to both unreinforced (plain concrete) and reinforced concrete sections. Influences from the subgrade reaction, slab dead load, and axial load eccentricity are considered in the analyses to develop an understanding of invert slab behavior and the influence, if any, second-order deformations may have in reducing the axial load capacity.

DISCLAIMER: The contents of this report are not to be used for advertising, publication, or promotional purposes. Citation of trade names does not constitute an official endorsement or approval of the use of such commercial products. All product names and trademarks cited are the property of their respective owners. The findings of this report are not to be construed as an official Department of the Army position unless so designated by other authorized documents. **Destroy this report when no longer needed. Do not return it to the originator.**

Contents

Conversion Factors, Non-SI to SI Units of Measurement.....	vi
Preface	vii
1—Introduction	1
1.1 Background	1
1.2 A Note of Caution Regarding Simple Methods to Estimate Limit- State Axial Load Capacity of Spillway Invert Slabs	3
2—Invert Slabs Designed to Corps Standards	4
2.1 Corps Guidance.....	4
2.2 Spillway Chute Floors	4
2.3 Floor Slab Anchorage	6
2.4 Floor Slab Reinforcing.....	6
2.4.1 Independent block plan	7
2.4.2 Continuous reinforcing plan.....	9
2.5 Floor Slab Joint Details.....	11
3—Invert Slab Limit-State Performance	13
3.1 Short Column Behavior	14
3.2 Long Column Behavior	14
4—Invert Slab Properties	16
4.1 Concrete	16
4.1.1 Strength	16
4.1.2 Modulus of elasticity	17
4.2 Reinforcing Steel	17
4.3 Invert Slab/Foundation Interface	18
4.4 Eccentricity of Axial Load.....	19
4.5 Effective Stiffness.....	21
4.6 Invert Slab Stiffness at Contraction Joint Locations.....	22
5—Invert Slab Limit-State Capacity	23
5.1 Interaction Diagrams.....	23
5.2 Invert Slabs on Rock.....	24
5.3 Invert Slabs on Earth.....	30
6—Assessing System Behavior.....	35
6.1 Continuous Reinforcing Plan.....	37

6.2 Independent Block Plan	39
7— Second-Order Deflection Effects	47
8—Summary, Conclusions, and Recommendations	56
8.1 Summary and Conclusions	56
8.2 Research and Development Needs.....	58
References	58
SF 298	

List of Figures

Figure 1-1.	Spillway wall/invert slab system behavior	2
Figure 2-1.	Invert slab drain section per EM 1110-2-2400, 2 Nov 64.....	5
Figure 2-2.	Uplift resistance for anchored invert slabs	7
Figure 2-3.	Independent block plan	8
Figure 2-4.	Continuous reinforcing plan.....	10
Figure 2-5.	Retaining wall-invert slab joint	12
Figure 3-1.	Long column versus short column behavior	15
Figure 4-1.	Winkler springs force-deformation curve for rock and earth foundations.....	20
Figure 4-2.	Eccentricity of axial load.....	21
Figure 4-3.	Invert slab contraction joint stiffness model	22
Figure 5-1.	Invert slab interaction diagram construction	24
Figure 5-2.	Interaction diagrams and supporting calculations for invert slabs on rock	26
Figure 5-3.	Interaction diagrams and supporting calculations for invert slabs on earth.....	31
Figure 6-1.	Line of action, 60-ft-wide invert slab, positive eccentricity = $0.25 T$	36
Figure 6-2.	Continuous reinforcing plan, rock foundation, 60-ft-wide invert slab, Class C site, positive eccentricity = $0.25 T$	38
Figure 6-3.	Continuous reinforcing plan, earth foundation, 60-ft- wide invert slab, Class C site, positive eccentricity = $0.25 T$	39

Figure 6-4.	Independent block plan, rock foundation, 60-ft-wide invert slab, Class C site, positive eccentricity = 0.25 T	40
Figure 6-5.	Independent block plan, earth foundation, 60-ft-wide invert slab, Class C site, positive eccentricity = 0.25 T	41
Figure 6-6.	Independent block plan, earth foundation, 60-ft-wide invert slab, Class D site, positive eccentricity = 0.25 T	42
Figure 7-1.	Independent block plan on earth, moment magnification effects	48

Conversion Factors, Non-SI to SI Units of Measurement

Non-SI units of measurement used in this report can be converted to SI units as follows:

Multiply	By	To Obtain
cubic feet	0.02831685	cubic meters
cubic inches	0.00001638706	cubic meters
feet	0.3048	meters
foot-kips	1,355.8181	meter-newtons
inches	0.0254	meters
kips	4.448222	kilonewtons
kips per square foot	47.88026	kilopascals
pounds (force)	4.448222	newtons
pounds (force) per square inch	0.006894757	megapascals
pounds (mass) per cubic foot	16.01846	kilograms per cubic meter
square feet	0.09290304	square meters
square inches	0.00064516	square meters

Preface

The work described herein was sponsored by Headquarters, U.S. Army Corps of Engineers (HQUSACE), as part of the Infrastructure Technology Research Program. The Program Manager was Ms. Yazmin Seda-Sanabria, Structural Engineering Branch, Geosciences and Structures Division, Geotechnical and Structures Laboratory (GSL), Vicksburg, MS, U.S. Army Engineer Research and Development Center (ERDC). The research was performed under Work Unit 33215a, entitled "Soil-Structure Interaction for Seismic Evaluation and Rehabilitation of Earth-Retaining Lock and Cantilever Walls" for which Dr. Robert M. Ebeling, Engineering and Informatic Systems Division (EISD), Information Technology Laboratory (ITL), Vicksburg, MS, ERDC, was the Principal Investigator. The HQUSACE Technical Monitor is Ms. Anjana Chudgar, CECW-EW.

The research was performed and this report written by Dr. Ebeling and Mr. Ralph W. Strom, Portland, OR, under the general supervision of Dr. Charles R. Welch, Chief, EISD; Mr. David R. Richards, Technical Director for Computational Sciences and Engineering, ITL; Dr. Jeffery P. Holland, Director, ITL; Dr. Mary Ellen Hynes, Technical Director for Civil Works Infrastructure and Geosciences, GSL; and Dr. David W. Pittman, Acting Director, GSL.

Commander and Executive Director of ERDC was COL James R. Rowan, EN. Director was Dr. James R. Houston.

1 Introduction

1.1 Background

Invert spillway slabs provide an important contribution to the overall stability of retaining walls, especially those earth-retaining L-walls and T-walls (sometimes referred to as cantilever retaining walls) that border spillway channels. Key to the seismic performance of spillway retaining walls is the stabilizing force exerted by the channel invert slab at the toe of the wall. This report discusses simple methods that can be used to estimate this stabilizing force. The magnitude of this stabilizing force, considered to be the limit state axial load capacity of the invert slab, is needed to properly assess the overall seismic stability of spillway channel L-walls and T-walls. This need has led to the development of the engineering methodologies discussed in this report.

In general, reinforced concrete and massive concrete earth-retaining structures tend to respond to earthquake shaking in one of three ways: (a) sliding of the retaining wall along its foundation-to-concrete base or within a “weaker” plane within its foundation; (b) rotating about a point along the concrete wall base or toe; or (c) rocking in place on its foundation. The particular response to earthquake shaking by an earth-retaining structure is dependent upon (a) the severity of the earthquake; (b) the geometrical configuration and mass configuration of the retaining wall system; (c) the type (i.e., soil or rock) of material within the foundation; (d) the stiffness of the foundation, the structural retaining wall and the retained soil; and (e) the (shear) strengths of the retained soil, the wall-to-foundation interface, and regimes within the foundation.

Since 1992 the U.S. Army Corps of Engineers has had an engineering methodology and simplified calculation procedure for the rapid assessment of retaining walls that slide during earthquake shaking, described in Ebeling and Morrison (1992). For Corps retaining walls that have a potential to rotate during a design earthquake event, an engineering methodology was developed to assess the permanent deformations (i.e., wall rotation) as well as the seismically induced loadings acting on the retaining structure. This type of simplified seismic analysis procedure is important to the seismic stability assessment of spillway retaining walls that are buttressed by invert spillway slabs (Ebeling and White, in preparation). Their procedure of analysis centers on the use of a PC-based computer program $C_{\text{orps}}W_{\text{all}}\text{Rotate-“Dry”}$ (sometimes referred to as $CWR_{\text{otate-“Dry”}}$) to perform an earthquake acceleration time-history based numerical analysis. The engineering analysis procedure requires as input an estimate of the

force per unit length of run of the invert slab that resists the potential of the retaining wall to slide into the spillway during earthquake shaking. The spillway wall/invert slab system before and after a seismic-induced permanent rotation is idealized in Figure 1-1 for a CWRotate-“Dry” analysis.

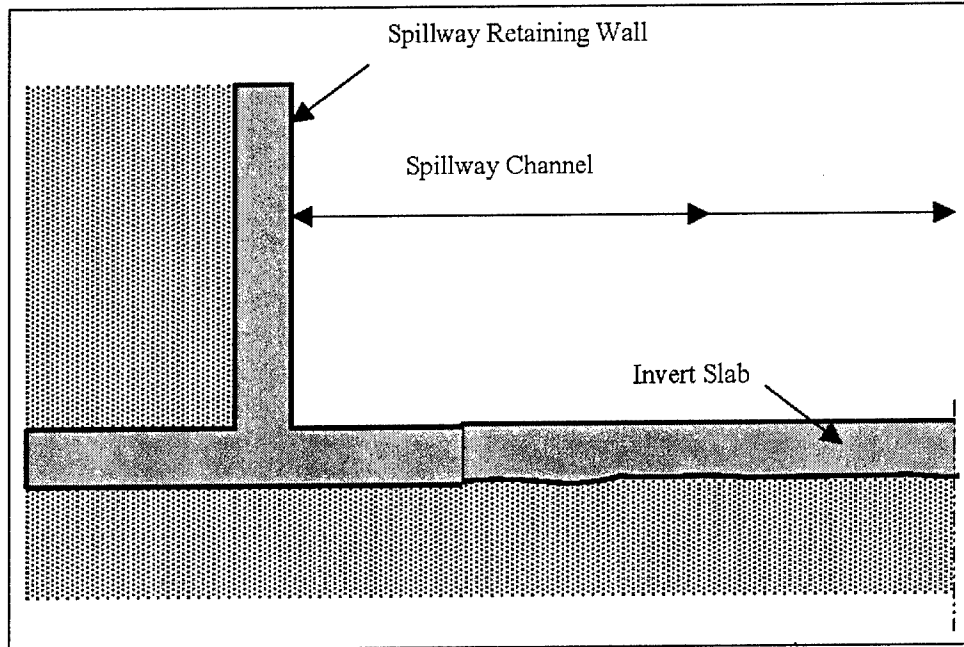

a. Prior to earthquake-induced permanent rotation

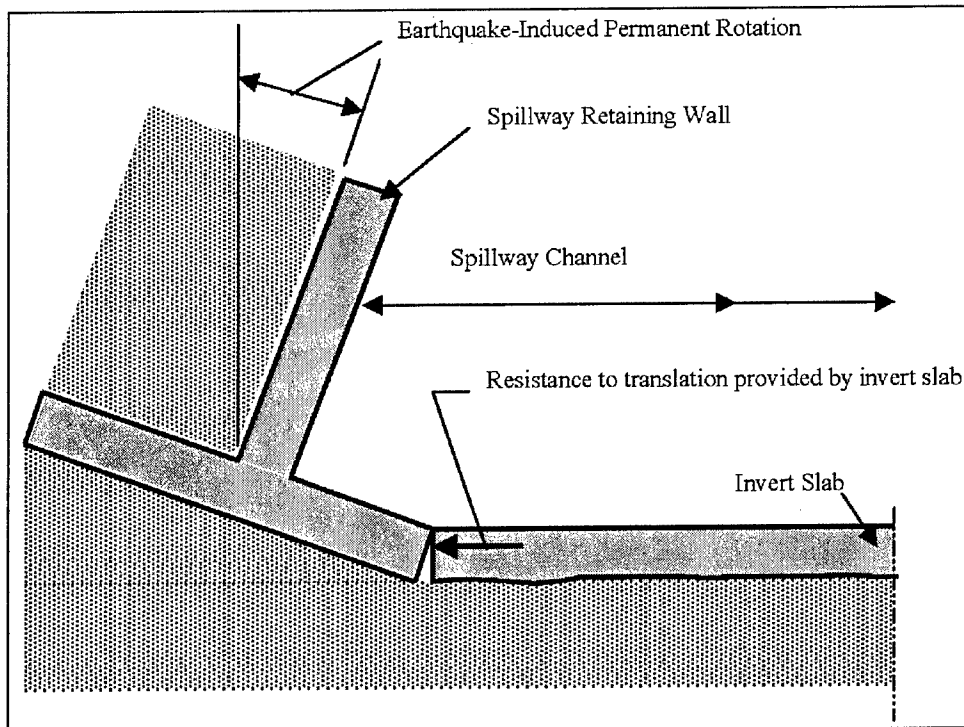

b. After earthquake-induced permanent rotation

Figure 1-1. Spillway wall/invert slab system behavior

The spillway wall/invert slab system is assumed to be symmetrical about the center line of the spillway channel, and the invert slab is assumed to act as a compression member subject to axial load combined with bending. Bending is due to eccentricity of the axial load with respect to the center line of the invert slab. This eccentricity is assumed to be positive, meaning the axial load line of action is always above the center line of the invert slab. This assumption is considered to be valid since the permanent rotation of the spillway wall is always toward the channel. Therefore, any contact between the spillway wall footing and the invert slab will always begin at their uppermost corners.

1.2 A Note of Caution Regarding Simple Methods to Estimate Limit-State Axial Load Capacity of Spillway Invert Slabs

It should be recognized that the behavior of systems involving structure-soil-foundation interaction, especially when subjected to time-varying earthquake ground motions, is complex. The procedures used herein to develop the limit-state axial load capacities of invert slabs are based on many simplifying assumptions, which to date have not been compared against the results of more sophisticated and comprehensive analytical studies or against the results of experimental model testing. Therefore, engineers are cautioned to assess and review the assumptions made in this report carefully to assure these assumptions are applicable to their particular retaining wall situation prior to application on their particular Corps project.

2 Invert Slabs Designed to Corps Standards

2.1 Corps Guidance

Design and construction details are important to invert slab performance. Therefore pertinent Corps guidance on invert slab design and construction is presented in this chapter.

On Corps projects, the design of existing spillway chute floors would most likely follow guidance provided in EM 1110-2-2400, "Structural Design of Spillways and Outlet Works," dated November 1964.¹ This guidance will form the basis for the parameters used in the research into the limit-state axial load capacity of spillway invert slabs. Based on Corps guidance, joint details and configurations, reinforcement details, and anchorage details typical to spillway invert slabs constructed on unyielding rock, yielding rock, and earth will be selected and used in the parametric studies to determine slab behavior and limit-state axial load capacity. Provisions from EM 1110-2-2400 important to the conduct of this research effort are presented in the following paragraphs.

2.2 Spillway Chute Floors (EM 1110-2-2400, paragraph 2-8b)

The design of a spillway chute floor depends on the foundation (i.e., unyielding rock, relatively yielding rock, or earth), velocity of flow, uplift head, and similar factors. Drainage to reduce uplift on spillway chute slabs is usually economical even though the reduction is relatively small. The probable hydrostatic uplift forces under adverse conditions, as partially relieved by the drainage system, should be estimated conservatively for the particular foundation and drainage system. Such a condition would be the empty channel after a rapid closure of the gates or drop in reservoir water level to the crest elevation of an ungated spillway with water in the foundation at maximum gradient under

¹ Spillway chute floor design guidance discussed in this chapter is taken from the 1964 version of EM 1110-2-2400 (superseded). References to EM 1110-2-2400 used throughout this chapter are to the superseded publication. The current EM 1110-2-2400 published in 2003 does not contain invert slab guidance.

reservoir conditions. If important differential foundation movement is anticipated, the effect thereof should be analyzed. If the slab is founded on rock and is anchored to the foundation, it is designed to withstand uplift and other probable forces with an ample factor of safety because of the uncertain magnitude of such forces.

Note that uplift pressures in rock foundations result from flow through discrete rock discontinuities (e.g., joints, faults and bedding planes). In some instances flow can occur along rock-to-concrete interfaces through gaps that develop to poor contact between the concrete slab and the rock foundation or differential slab movements. Uplift pressures as a result of flow within discrete discontinuities is discussed in Murphy, Ebeling, and Andersen (2002); Ebeling, Pace, and Morrison (1997); Ebeling and Pace (1996); and Stone and Webster Engineering Corporation (1992).

For a spillway chute slab anchored to rock without a drainage blanket where investigations do not indicate larger uplift pressures under adverse conditions, the slab combined with the anchorage system should be designed for at least 5 ft¹ of excess hydrostatic uplift at the invert. With such a slab, when the channel is empty after rapid closure of the gates or drop in reservoir to the crest of an ungated spillway, the pressure some distance from a drain will be relieved slowly even by a good drainage system and the effectiveness of the system may be reduced by plugging. A drainage system typically used for invert slabs on rock is illustrated in Figure 2-1.

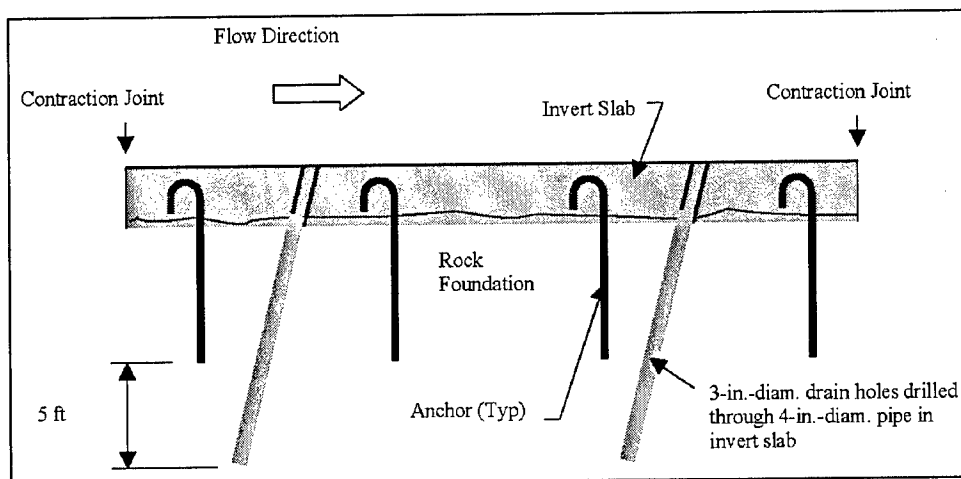

Figure 2-1. Invert slab drain section per EM 1110-2-2400, 2 Nov 64

The slab should be at least 12 in. thick on a rock foundation and should be thicker where required by foundation conditions and probable uplift forces. A slab on earth is usually thicker than one on rock (other conditions being similar) because the weight of the slab must be relied on to withstand uplift, possible vibration, and differential settlement without benefit of anchorage to the foundation. Potential uplift under a slab on earth with a drainage system under the slab generally will be less than for a slab in contact with rock under otherwise

¹ A table of factors for converting non-SI units of measure to SI units is found on page vi.

similar conditions, because of more rapid relief provided by the drainage system. However, forces resulting from differential settlement of the earth foundation usually will be greater. Therefore, a slab 2 ft thick that will withstand about 5 ft of hydrostatic uplift or equivalent generally is a minimum for earth foundations. Analysis of hydrostatic uplift or differential foundation movement may show a thicker slab is needed. Anchorage to rock foundations, drainage systems under the slab, and joints and reinforcement for spillway floor slabs are discussed in the following EM 1110-2-2400 paragraphs.

2.3 Floor Slab Anchorage (EM 1110-2-2400, paragraph 2-8f)

Anchorage is usually provided for spillway chute and stilling basin floor slabs on rock foundations by dowels grouted in holes drilled into the rock to a depth sufficient to engage a mass of rock the submerged weight of which will withstand the net upward forces, assuming the mass of rock bounded by a 90-deg apex angle at the bottom with allowance for overlap. Anchor resistance is illustrated in Figure 2-2 for this criterion.

This criterion applies to other anchorages also. Anchorage for a spillway chute floor slab without a drainage blanket should be provided for at least 5 ft of excess uplift at the invert when conditions are favorable. A larger uplift pressure should be used for anchorage design when investigations indicate higher values under natural or reservoir conditions. The uplift forces acting on a stilling basin floor slab are generally greater than the uplift on a chute floor.

Note: The aforementioned floor slab anchorage design requirements are assumed to apply to older designs. More recent designs may have followed similar guidance as presented in Chapter 9 of EM 1110-1-2908 (Headquarters, U.S. Army Corps of Engineers 1994). Additional guidance on tiedown design can be found in Paragraph 5.9 of Geotechnical Engineering Circular No. 4 (Sabatini, Pass, and Bachus 1999).

2.4 Floor Slab Reinforcing (EM 1110-2-2400, paragraph 2-8g)

In thick slabs on rock foundations normally covered with tailwater, horizontal reinforcement is not necessary except in the baffles. Uplift on a slab should be taken care of by adequate anchors.

Two general plans of reinforcement for crack control in spillway and stilling basin floor slabs are in common use. In one plan the slab is divided into approximately square blocks by contraction joints, parallel and perpendicular to the channel or basin center line and close enough to avoid serious shrinkage and temperature cracking with the use of nominal reinforcement, which does not extend across the joints. In the other plan the reinforcement steel is continuous through all joints (which thus become construction joints) and a somewhat larger

percentage of steel is used. Details of these two plans are discussed in the following paragraphs.

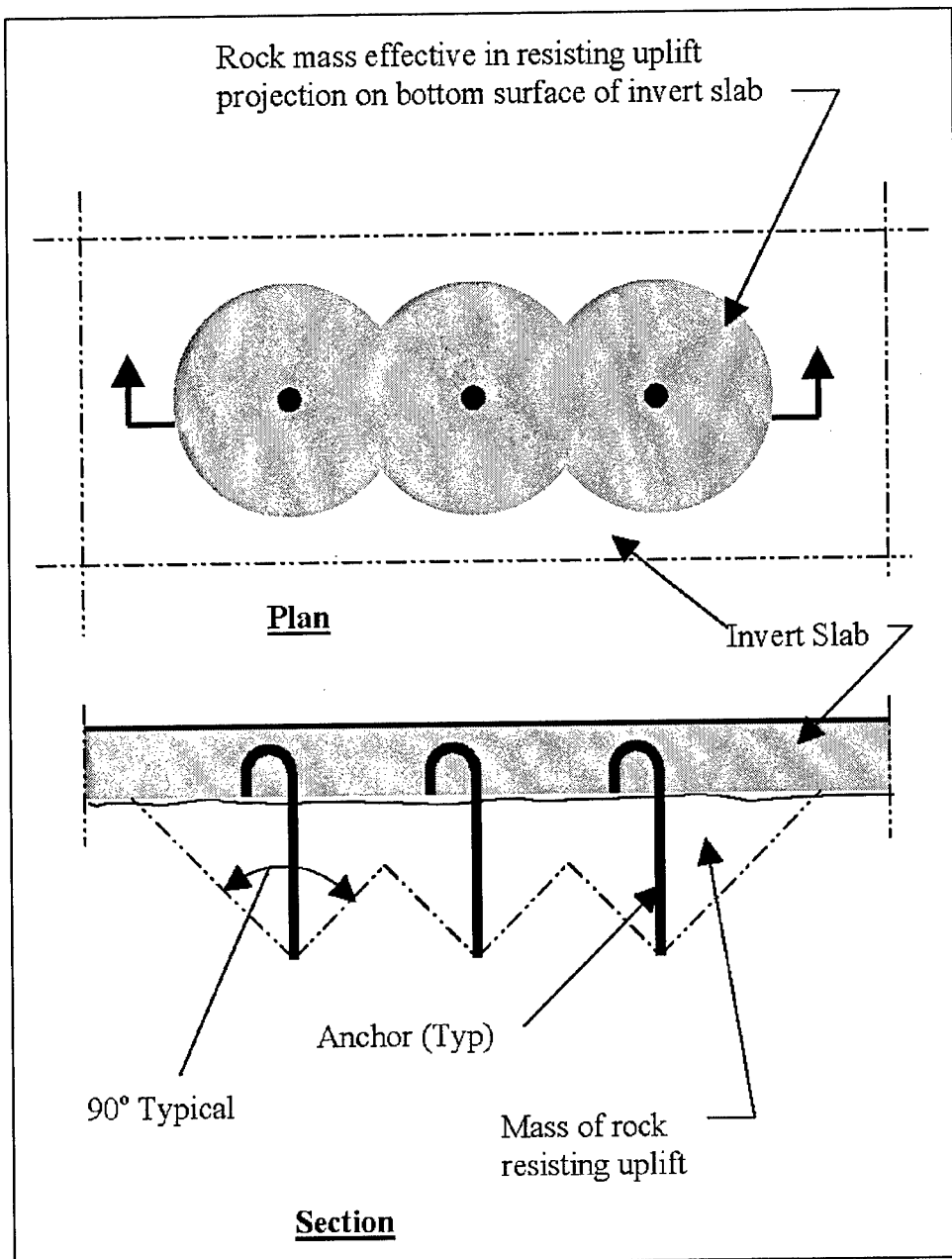

Figure 2-2. Uplift resistance for anchored invert slabs

2.4.1 Independent block plan

This plan provides satisfactory crack control with a minimum amount of reinforcement steel for slab on unyielding rock. However, on relatively yielding rock or earth foundations the independent floor blocks are subject to possible movement of adjacent blocks. With this system of reinforcement, a key at each transverse contraction joint (extending into the foundation under the joint,

attached to the slab downstream and supporting the slab from the upstream joint) is required on earth foundations and on some yielding rock. This key prevents the downstream side of the joint from being raised above the upstream side, as water at high velocity striking such a projection would increase the hydrostatic pressure in the joint and hence the uplift under the slab. The higher the velocity, the more serious will be the conditions resulting from such relative movement. The keys also increase resistance to possible downhill movement on an earth foundation and serve as seepage cutoffs downstream from transverse drains.

The independent blocks of a slab are reinforced with a small amount of steel to prevent harmful cracking resulting from shrinkage and temperature stresses not relieved by the contraction joints, and, on yielding foundations, to avoid possible cracking from differential settlement. Usually a slab on unyielding rock is reinforced in the top face only because bond between the concrete and rock on the bottom is relied on to distribute shrinkage cracks and to minimize bending stresses in the anchored slab for the assumed uplift head. A slab on earth is reinforced in both the top and bottom faces unless it is so thin that reinforcement is located in the center. The usual slab is thick enough for reinforcement in both faces. The independent blocks on unyielding rock are reinforced with a minimum of 0.15 percent steel in the top face each way with the maximum amount being #6 bars at 12-in. centers. Blocks on favorable earth foundations are reinforced with a minimum of 0.20 percent steel each way, approximately two-thirds in the top face and one-third in the bottom with a maximum consisting of #6 bars at 12-in. centers. Additional reinforcement should be provided for unfavorable foundation conditions or for high hydrostatic uplift pressures.

Details important to independent block plan construction are presented in Figure 2-3.

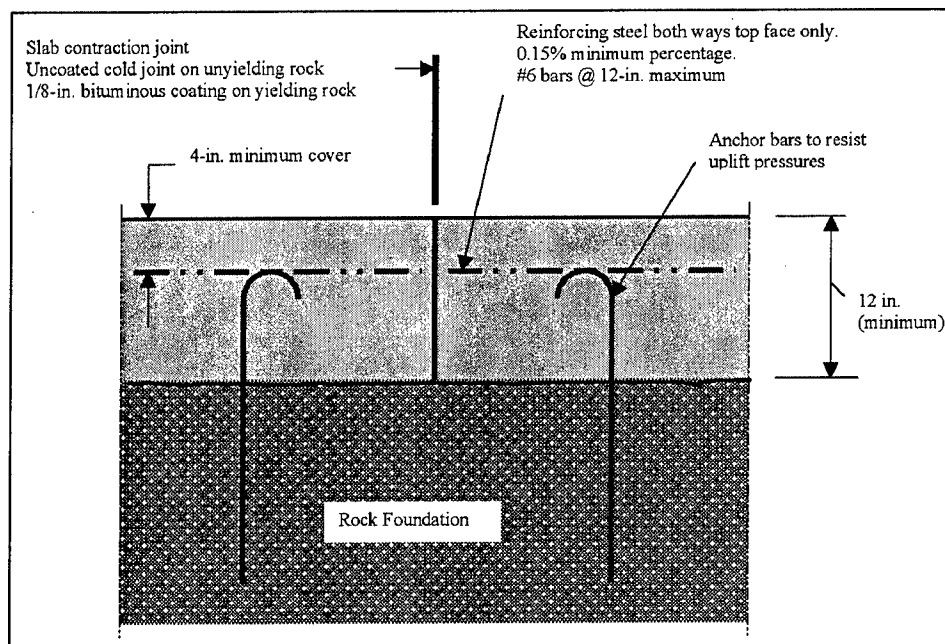

a. Invert slab on unyielding or yielding rock

Figure 2-3. Independent block plan (continued)

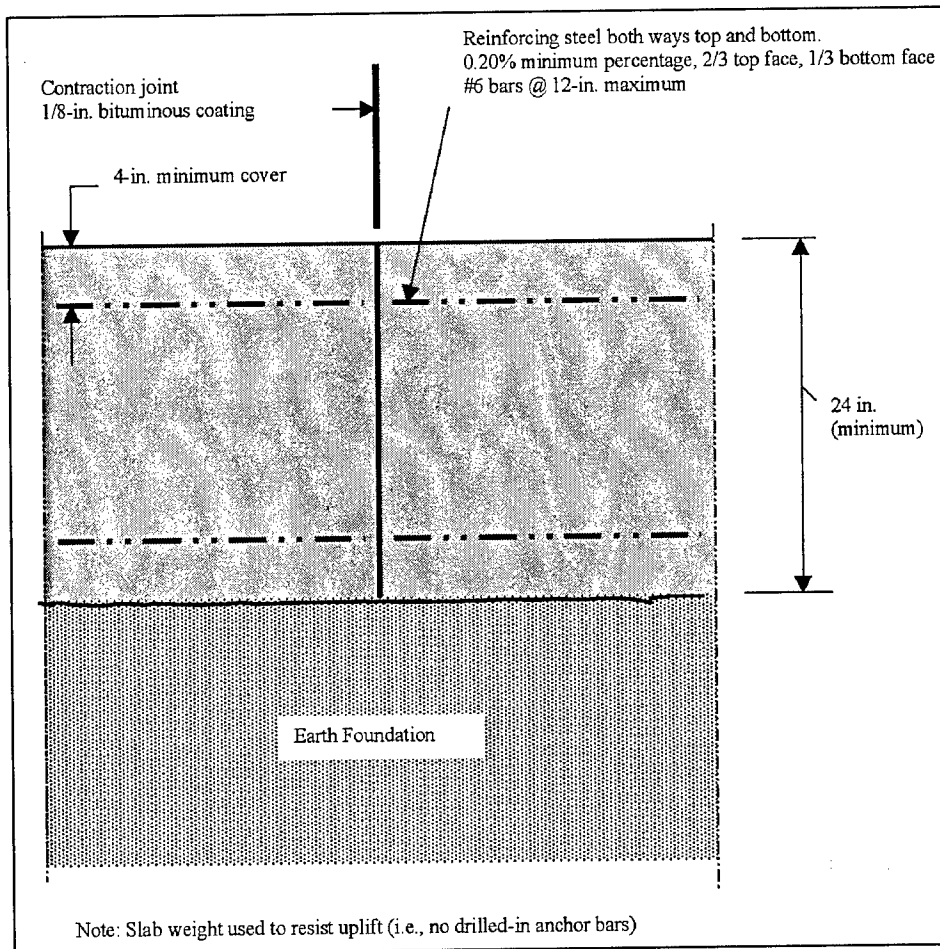

b. Invert slab on earth

Figure 2-3. (concluded)

2.4.2 Continuous reinforcing plan

With this type of reinforcing, as the entire floor is tied together, the differential movement of adjacent blocks is largely prevented and keys at the joints are not needed. Therefore, this plan is advantageous for a slab on relatively yielding rock or earth. According to EM 1110-2-2400 a rational method of design for a thin continuous floor slab on a yielding foundation has been outlined by Harza (1951) and others in this engineering manual. This method is acceptable for slabs approximately 12 in. thick or less. The following criteria for design are summarized therefrom:

- a. A slab of maximum flexibility that will accommodate itself to settlement without the formation of more than minute and harmless hairline cracks. In the interest of flexibility, the steel should be in the center of the slab and the slab should be no thicker than needed to protect the steel; hence the direct application is limited to a thin slab. The steel should be sufficient as beam reinforcement so that at its elastic limit the concrete would crush in bending rather than the steel elongating permanently.

- b. A slab that contains enough steel to permit the formation of only minute hairline cracks as the result of shrinkage. There should be sufficient steel so that the total tension in the steel at its elastic limit would exceed the total tension in the concrete at the breaking point to prevent concentration of shrinkage at the construction joints and accidental cracks, which would thereby be enlarged.

For this system of reinforcing it is economical to use hard grade reinforcing steel with a high yield point. Based on these criteria, with steel having a yield point of 50,000 psi and concrete with a tensile strength of 300 psi, the required cross-sectional area of the reinforcing steel is 0.6 percent of the cross-sectional area of the slab. Experience with such slabs that have been constructed and tested has shown that the computed amount of steel is greater than necessary and that reinforcing equal to 0.5 percent of the area is adequate.

The reinforcing steel percentage for continuous slabs thicker than 12 in. should be reduced still further. However, no rational method for design of thick continuously reinforced slabs on yielding foundations is available.

Details important to continuous reinforcing plan construction are presented in Figure 2-4.

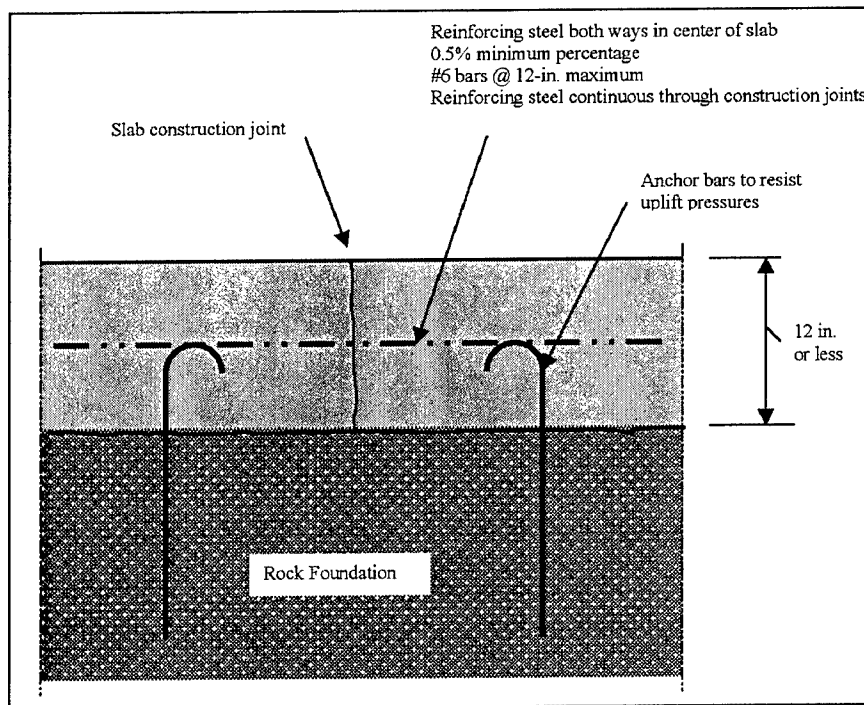

a. Invert slab on yielding rock

Figure 2-4. Continuous reinforcing plan (continued)

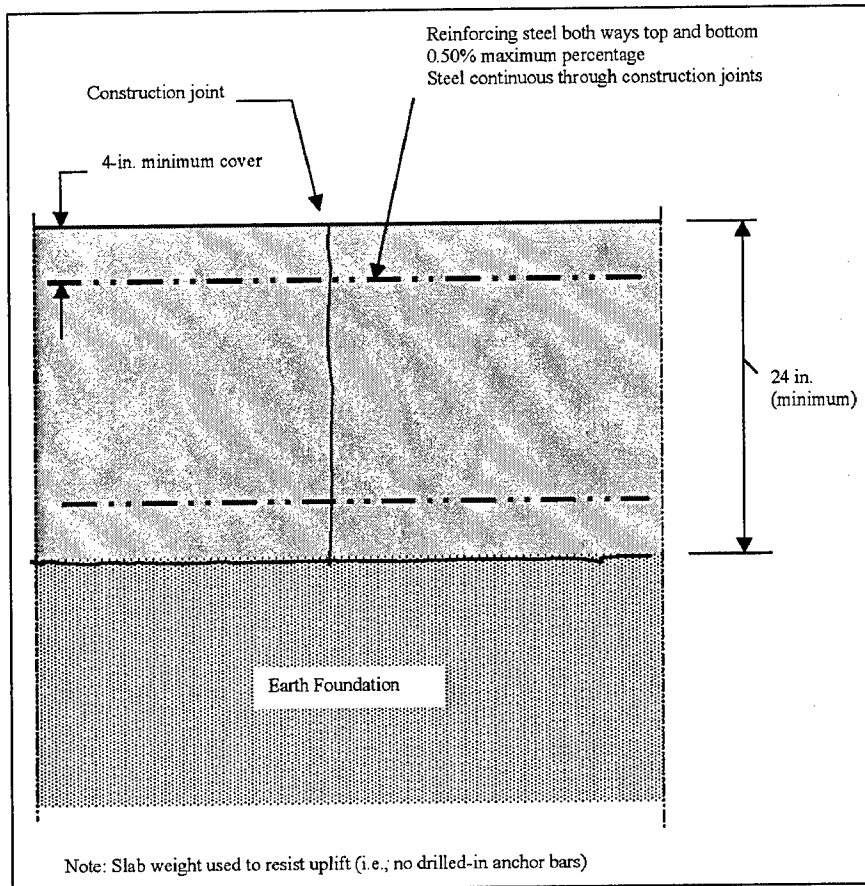

b. Invert slab on earth

Figure 2-4. (concluded)

The stress reinforcement of chute floor slabs should be protected with a minimum of 4 in. of concrete. The stress reinforcement of stilling basin floor slabs generally is protected with a minimum of 6 in. of concrete, and baffle blocks should have greater protection.

2.5 Floor Slab Joint Details (EM 1110-2-2400, paragraph 2-8h)

The spacing of contraction and construction joints will be controlled by the maximum width of a concrete slab that can be placed and finished without difficulty. Generally joint spacing is 20 to 30 ft. However, when keys are required at construction joints, it may be practicable to space them as much as 50 ft on center with one construction joint midway between each pair of contraction joints to reduce the number of keys.

The treatment of contraction joint surfaces in floor slabs varies with the amount of movement expected. For floor slabs on unyielding rock, contraction joints can be uncoated cold joints. A coating of 1/8-in. minimum thickness of bituminous mastic will provide for considerable differential settlement on an

earth foundation. Where this is insufficient to provide for expected movement resulting from differential settlement and expansion (exceeding initial shrinkage), an expansion joint with premolded expansion joint filler of the thickness needed can be used. Experience has proven cork filler to be unsatisfactory. An expansion joint may be needed between the floor slab and adjacent separate wall.

Generally, water stops are not required in contraction joints in chute floor slabs on unyielding rock, but are required in slabs on earth to minimize the water pressure in the slab drainage system. The contraction or expansion joint at the junction of the weir with the floor slab downstream is treated like a floor slab joint. Rubber or polyvinyl chloride water stops (dumbbell shape) are preferred. Water stops are not required in construction joints.

It is advantageous, especially if the velocity in the chute is high, to have the concrete surface downstream from each transverse joint a little lower (say 1/2-in.) than that upstream to overcome the effects of irregularities in finishing and assure that the downstream block will not project above the upstream one. Flowing water striking such a projection could increase materially the uplift under the slab.

Invert slab joint details for the longitudinal direction are shown in Figures 2-3 and 2-4. Either an expansion or contraction joint separates the spillway retaining wall from the invert slab. This detail is illustrated in Figure 2-5.

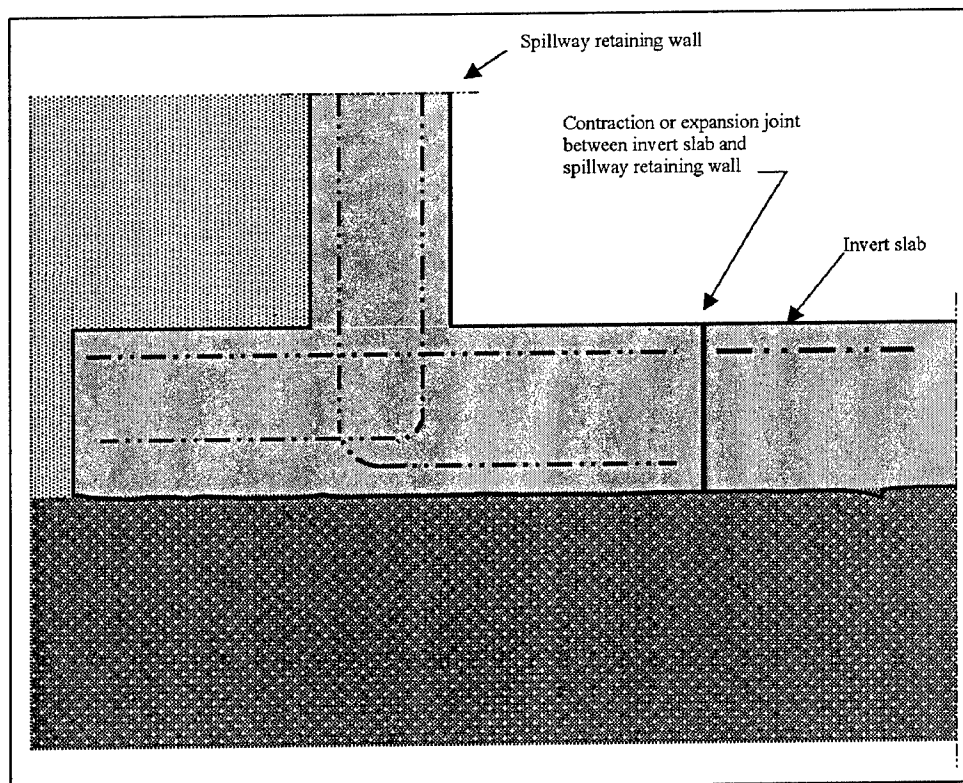

Figure 2-5. Retaining wall-invert slab joint

3 Invert Slab Limit-State Performance

The invert slab is essentially a beam on elastic foundation. The objective of this study is to determine its limit-state capacity when axially loaded by adjacent spillway retaining walls during a major seismic event. Seismic forces are delivered to the invert slab due to the inertial response of the wall-backfill system to earthquake ground motions. These seismic forces are considered to represent the total axial force demand on the invert slab. Inertial effects due to vertical and horizontal accelerations on the invert slab itself are not considered in this simple evaluation.

Horizontal acceleration effects on the invert slab were not considered, in part because lateral load transfer from the invert slab to the foundation by shear friction was also not considered. Since the axial load demand at the spillway wall-invert slab joint will have a positive eccentricity (thus bending the slab downward into the foundation), a transfer of axial load through shear friction into the foundation should occur. This positive benefit should more than offset any additional axial load demands on the invert slab due to horizontal acceleration.

Vertical acceleration of an invert slab due to earthquake ground motions was not considered, even though the associated inertial response could reduce the effective weight of the slab. For those slabs founded on earth this could result in a somewhat longer effective unsupported length. For slabs on rock, higher tensile stress demands at the slab-rock interface are possible. Peak vertical acceleration demands on a long, slender invert slab, however, are likely to be out of phase with the peak axial load demands generated by the dynamic response of the retaining wall system to earthquake ground motions. Since the resulting interaction of these two different system responses is unclear and given all of the other simplifying assumptions made, vertical acceleration effects related to the invert slab were not included.

As with columns, the axial load behavior of invert slabs can be categorized as either “short column” behavior or “long column” behavior.

3.1 Short Column Behavior

The short column category is used to identify those slabs on ground in which secondary moment effects due to column deflection (i.e., $P \cdot \Delta$ effects) can be disregarded. The short column designation is used to denote a slab with a strength equal to or greater than that computed for the cross section using the forces and moments obtained from a nominal analysis and the normal assumptions for combined bending and axial load (MacGregor, Breen, and Pfrang 1970).

For all practicable purposes, columns with L/t ratios less than 7.5 can be regarded as falling into the short column category (MacGregor, Breen, and Pfrang 1970) where L is the unsupported length (i.e., length of span subjected to $P \cdot \Delta$ effects) and t is the slab thickness.

Most slabs on ground will either be fully supported or have "effective" L/t ratios less than 7.5 because

- a. The foundation provides lateral support in the downward direction.
- b. For slabs on rock, bond between the slab and foundation provides resistance against lateral movement in the upward direction. (Note: This assumes competent rock foundations without significant joints, faults, or bedding planes that could prevent bonding between the invert slab and rock foundation and otherwise impair the ability of the slab-foundation system to act as a composite mass system and allow for tension transfer through the foundation.)
- c. For slabs on rock, anchors are often used to resist uplift, and these provide lateral support in the upward direction.
- d. For slabs on earth, the weight of the slab provides resistance against lateral movements in the upward direction.

3.2 Long Column Behavior

Slabs on ground falling into the "long column" category would be those slabs whose strength is reduced by second-order deformations. When end eccentricities are positive (i.e., eccentricity causes slab ends to curl upward), and where such bending displacements are not resisted by slab-foundation interface bond or by rock anchors, it is possible that second-order deformations could reduce the axial capacity of the invert slab. Under such conditions, a rational second-order analysis, one that considers the effect of slab dead load on reducing second-order deformations, may be required. Long column behavior can result in a material failure at axial loads less than that associated with a short column failure, or can lead to stability (i.e., buckling) failure. Short and long column conditions are illustrated on Figure 3-1.

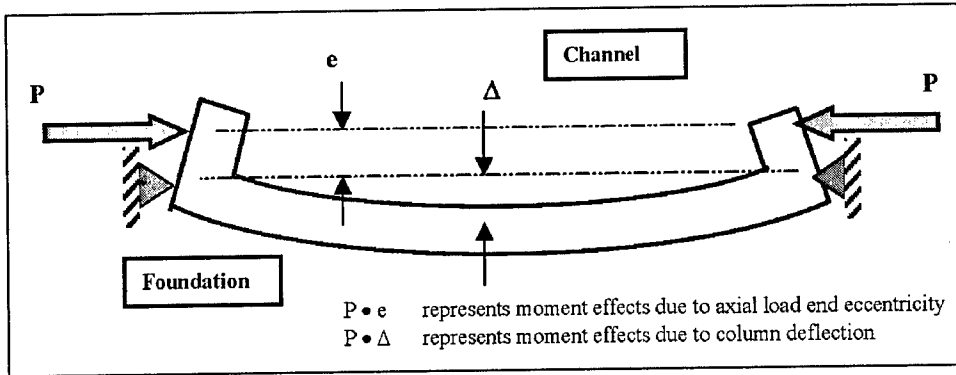

a. $(P \cdot e)$ and $(P \cdot \Delta)$ deflection effects for positive eccentricity condition; deflection into foundation

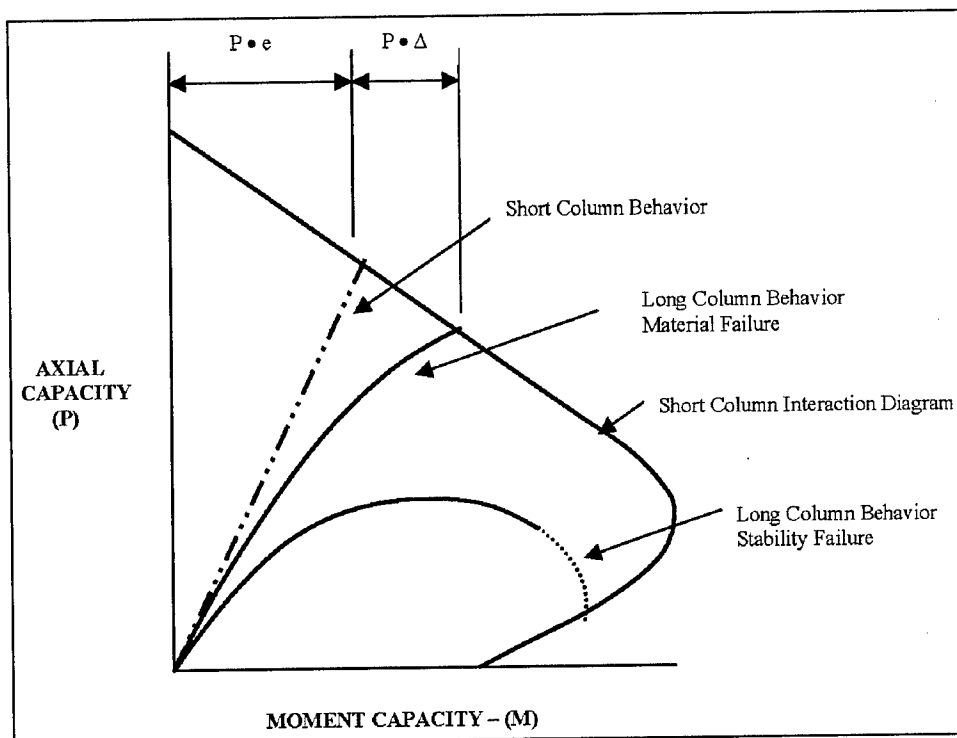

b. $(P \cdot e)$ and $(P \cdot \Delta)$ axial capacity reduction effects
 Figure 3-1. Long column versus short column behavior

Information is presented herein to identify conditions that can lead to possible "long column" behavior, and to provide guidance on the impact of "long column" behavior, if any, on the limit-state axial load capacity of spillway invert slabs on ground.

4 Invert Slab Properties

Two subsets of invert slabs will be assumed for the limit-state analyses: invert slabs constructed using the independent block plan and the continuous reinforcing plan. Parameters important to both subsets are described in the following text.

4.1 Concrete

All concrete invert slabs are reinforced. However, the percentage of reinforcement is low (i.e., 0.15 to 0.50 percent) and the steel can be limited to a single layer located at the upper face, or at the center of the slab. The cover that is provided to the reinforcing steel for protection can range from 4 to 6 in. The strength interaction diagram for invert slabs can be developed considering the flexural capacity provided by the reinforcing steel acting in tension or the flexural capacity provided by the concrete in tension (i.e., modulus of rupture). Simple techniques to construct both types of interaction diagrams will be demonstrated in subsequent sections of the report.

4.1.1 Strength

For analysis purposes the concrete used in invert slab construction is assumed to have a minimum compressive strength of 3,000 psi.

The tensile strength of concrete is strain rate sensitive with higher strain rates yielding higher tensile strength values. The tensile strength of concrete is determined by direct tensile tests, splitting tensile tests, or flexural tests (i.e., modulus of rupture tests). A description of each test and a discussion of the interrelationship of test results is described in the widely referenced Raphael (1984) report. With direct tensile testing, the line of failure is in the mortar with the strength of the mortar controlling the tensile strength of the concrete. With splitting tensile testing, the plane of failure is restricted to the line of split and goes through aggregate as well as mortar, thus providing higher tensile values than those determined by direct tensile testing. This issue is covered in Appendix E of EP 1110-2-12 (Headquarters, U.S. Army Corps of Engineers

1995b).¹ It should be noted that Raphael attributes the lower direct tensile strength results to drying shrinkage that takes place in the specimen, rather than to the different plane of failure conditions cited in Appendix E of EP 1110-2-12.

In the flexural test, a rectangular beam is loaded at the third points until a flexural failure occurs. The computed tensile stress at failure is termed the modulus of rupture. Since flexural performance is the quantity of interest with respect to invert slab behavior, the modulus of rupture is used when determining the flexural capacity of unreinforced concrete sections. The modulus of rupture used in the evaluation of flexural capacity is assumed to be equal to $7.5\sqrt{f'_c}$, where f'_c is the specified compressive strength of the concrete in psi, or 411 psi for concrete with a compressive strength of 3,000 psi. This value is consistent with ACI 318 (American Concrete Institute (ACI) 2002) with respect to determination of the moment that causes flexural cracking and is as suggested by Liu and McDonald (1978) as representative of the flexural tensile capacity of concrete at high strain rates.

4.1.2 Modulus of elasticity

The modulus of elasticity E_c is assumed to be a function of the concrete compressive strength. Using the methodology prescribed in ACI 318 (ACI 2002):

$$E_c = w^{1.5} 33\sqrt{f'_c} \text{ psi}$$

where w is the unit weight of concrete in pounds per cubic foot = 150 lb/cu ft. Thus for concrete with a compressive strength of 3,000 psi, the modulus of elasticity is equal to 3,320,000 psi (478,000 ksf).

4.2 Reinforcing Steel

Reinforcing steel is assumed to meet American Society for Testing and Materials (ASTM) A615 standards (ASTM 2003). The yield strength can be either 40,000 psi, 50,000 psi, or 60,000 psi. For most existing invert slabs the yield will be equal to 40,000 psi for slab constructed using the independent block plan, and equal to 50,000 psi for slabs constructed using the continuous reinforcing plan.

¹ Appendix E of this engineering publication was prepared by Robert W. Cannon and provides important information related to the tensile strength of concrete. Mr. Cannon is a nationally recognized and widely published expert in the field of concrete materials and a member of ACI committees on mass concrete, nuclear structures, anchorage to concrete, and the Concrete Material Research Council.

4.3 Invert Slab/Foundation Interface

All invert slabs, whether constructed on rock or earth, are capable of transmitting compressive stresses across the slab/foundation interface. Slabs constructed on rock can also transmit tensile stress across the slab/foundation interface, provided the rock foundations are competent (i.e., without significant joints, faults, or bedding planes that could prevent bonding between the invert slab and rock foundation system and allow for tension transfer through the foundation). Interaction effects (i.e., displacements and bearing pressures) along the interface boundary are approximated using a Winkler spring type analysis. The Corps computer program CBEAMC (Dawkins 1994) is used in subsequent sections of the report to evaluate interface boundary effects. Winkler soil and rock springs are assumed to be nonlinear with unlimited capacity to carry loads that put the invert slab/foundation interface in compression and a limited ability to carry loads that put the invert slab/foundation interface in tension. The Winkler springs were developed using Equation 4-6 of FEMA 356 (Federal Emergency Management Agency (FEMA) (2000)). Spring stiffnesses were determined for Class A (hard rock), Class C (very dense soil and soft rock), and Class D (stiff soil) site conditions. Classifications are in accordance with Paragraph 1.6.4.1 of FEMA (2000). These classifications likely cover the range of conditions at most Corps projects, although a site-specific project assessment is recommended by the authors of this report. Shear wave velocities selected are 5000 fps, 2000 fps, and 600 fps for Classes A, C, and D, respectively. These form the basis for soil and rock spring calculations.

For rock foundations the capacity of the invert slab/foundation interface to carry tension is based on an Electric Power Research Institute report (Stone and Webster Engineering Corporation 1992).

Stone and Webster Engineering Corporation (1992) indicates the average direct tensile strength of concrete-to-rock contacts is 162 psi (assumes rock foundations are competent without significant joints, faults, or bedding planes). Assuming the direct tensile strength will increase by 50 percent or more for rapid strain rates such as those that occur during earthquakes, a direct tensile strength of 250 psi (36 ksf) is used for the concrete-to-rock interface. Designers should determine site-specific interface tensile strengths for their particular Corps project to assure the behavior captured in this study is applicable.

Mathcad (Mathcad 1998) calculations for the Winkler spring coefficient k_v are illustrated as follows for a Class C site with a shear wave velocity of 2000 fps:

Mathcad Calculations:

File: Spillway Walls \ Winkler 1

June 8, 2003

Foundation Stiffness for Rock and Soil Sites

Shear modulus per Equation 4-6, FEMA 356

Shear wave velocity per Paragraph 1.6.1.4.1, Class C, Very dense soil or soft rock
"Prestandard and Commentary for the Seismic Rehabilitation of Buildings"

November 2000

$$\gamma := 120 \frac{\text{lbf}}{\text{ft}^3} \quad v_s := 2000 \frac{\text{ft}}{\text{sec}} \quad g = 32.174 \frac{\text{ft}}{\text{sec}^2}$$
$$G := \frac{\gamma \cdot v_s^2}{g} \quad G = 1.492 \cdot 10^7 \frac{\text{lbf}}{\text{ft}^2} \quad \nu := 0.30 \quad B := 20 \cdot \text{ft}$$

$$k_{sv} := \frac{(1.3 \cdot G)}{B \cdot (1 - \nu)} \quad k_{sv} = 1.385 \cdot 10^6 \frac{\text{lbf}}{\text{ft}^3} \quad k_{sv} = 801.691 \frac{\text{lbf}}{\text{in}^3}$$

Use subgrade modulus = 1385 kips / square foot / foot of displacement

The nonlinear Winkler springs used for rock and soil foundations (Class C sites) are illustrated in Figures 4-1a and 4-1b, respectively.

4.4 Eccentricity of Axial Load

Axial loads assumed in the various limit-state analyses are applied eccentrically to the invert slab. These loads are delivered to the invert slab by the retaining wall footing. Initial contact will occur between the uppermost corners of the retaining wall footing and the invert slab as seismic-induced rotation of the retaining wall takes place (i.e., rotation into the spillway invert channel). As corner yielding and possible spalling occur as the two corners bear against one another, the invert slab resistance line of action will move closer to the neutral axis. The line of action assuming plastic interface pressure distribution most likely will fall halfway between the neutral axis and top of slab as shown in Figure 4-2.

Therefore the eccentricity assumed for the limit-state analyses is set equal to $0.25 T$, where T is the slab thickness.

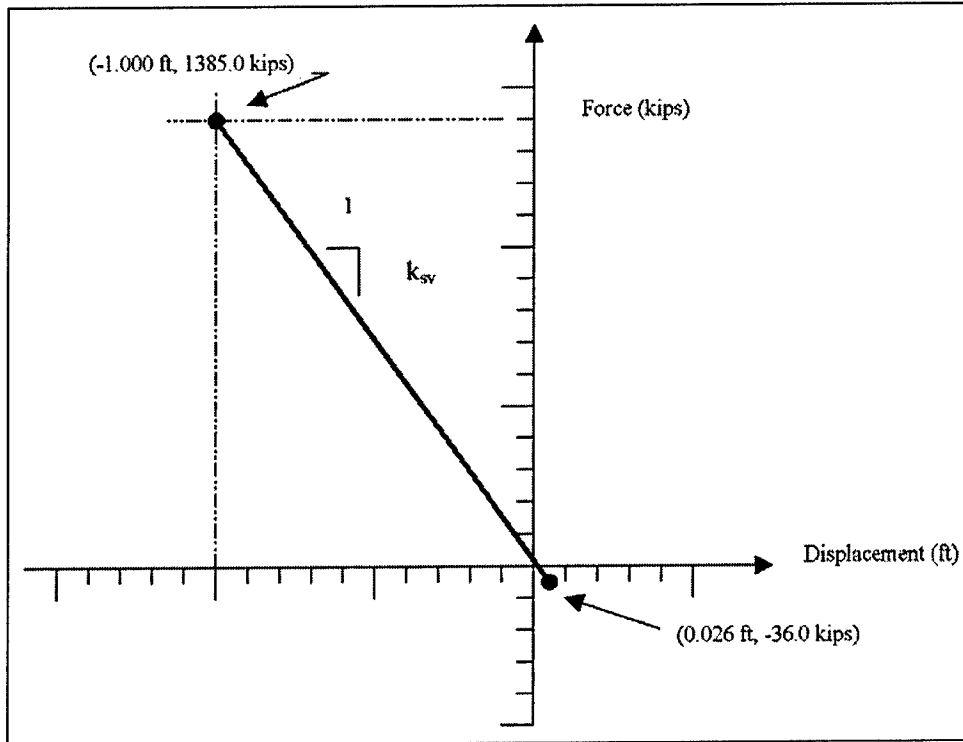

a. Rock foundation

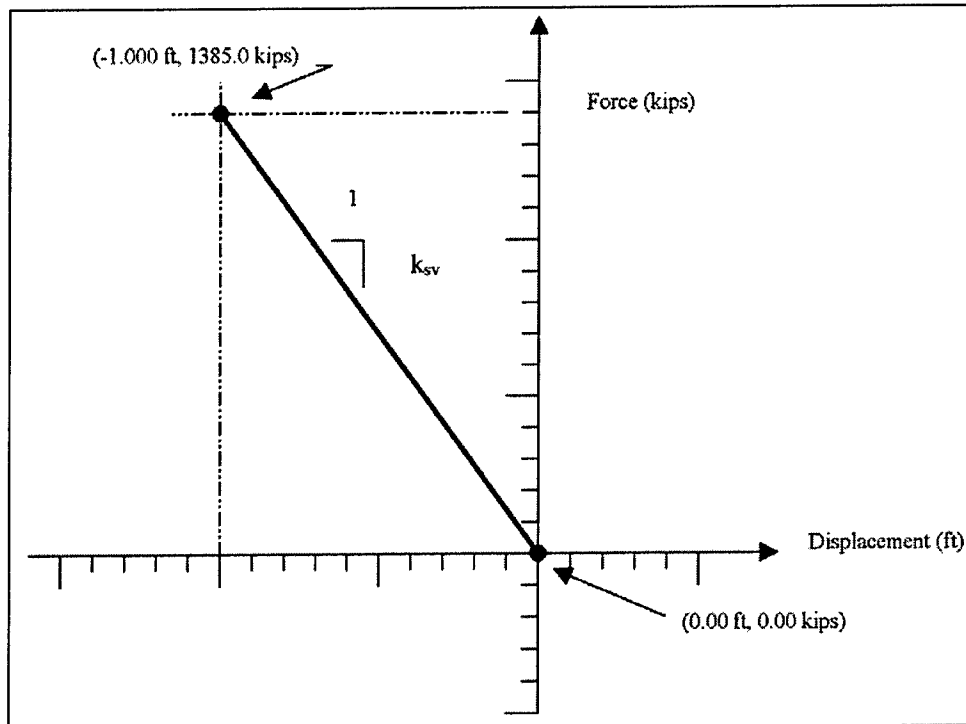

b. Earth foundation

Figure 4-1. Winkler springs force-deformation curve for rock and earth foundations

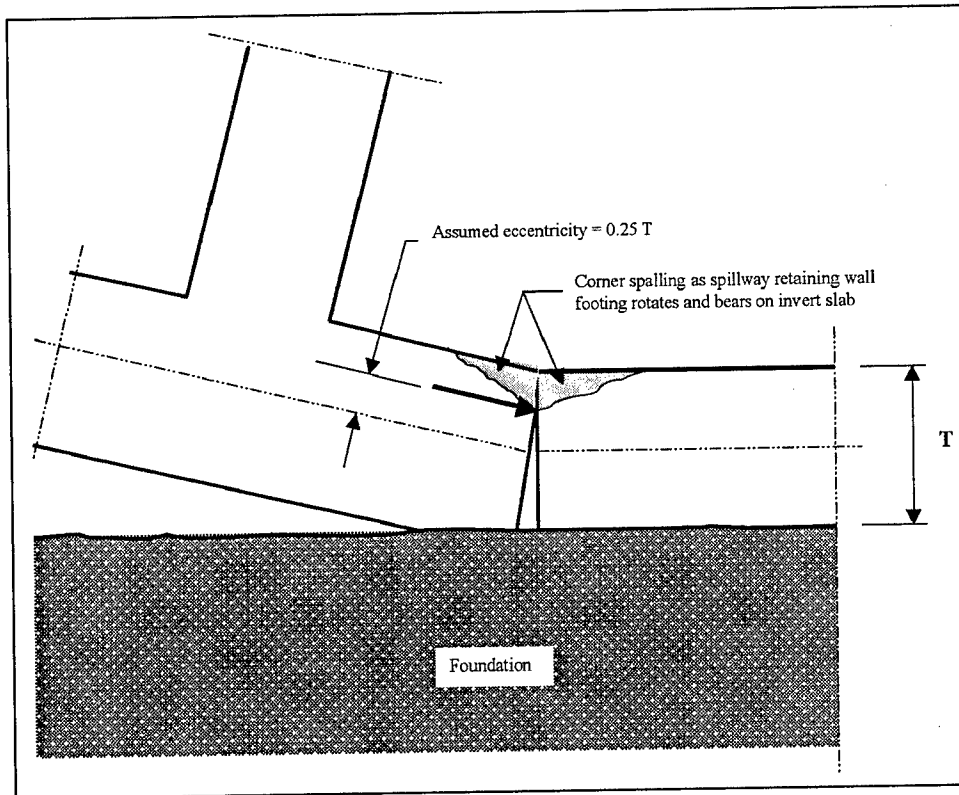

Figure 4-2. Eccentricity of axial load

4.5 Effective Stiffness

According to ACI 318 (ACI 2002) the stiffness (EI) used in an elastic analysis used for strength design (i.e., limit-state design) should represent the stiffness of members immediately prior to failure. This is particularly true for second-order analyses, which are used to predict lateral deflections at loads approaching ultimate. The effective stiffness (i.e., cracked section stiffness) is always less than the gross section stiffness with greater reductions occurring under conditions where cracking propagates extensively throughout the length of the member with crack orientation in a direction normal to the slab section. However, in the case of lightly reinforced invert slabs, with cracking moment capacities equal to or larger than nominal moment capacities, any cracking that occurs will be limited to discrete locations. At limit-state conditions single cracks in a direction normal to the slab section may appear at high tensile stress locations, but they will have little potential to spread throughout the slab. Therefore for analyses contained herein, the effective stiffness will be assumed equal to the gross stiffness.

4.6 Invert Slab Stiffness at Contraction Joint Locations

The invert slabs are considered to be incapable of transferring moments and shears across contraction joints. This behavior is approximated in the CBEAMC analyses for the various independent block plan systems by reducing the modulus of elasticity in a discrete region centered on each contraction joint location (0.05 ft each side of the contraction joint). The modulus of elasticity in this half-foot region is set equal to 478 ksf, or one one-thousandth of the modulus of nonjoint locations. The resulting stiffness (EI) at contraction joints is therefore one one-thousandth of the stiffness of nonjoint locations. This analytical model is illustrated in Figure 4-3.

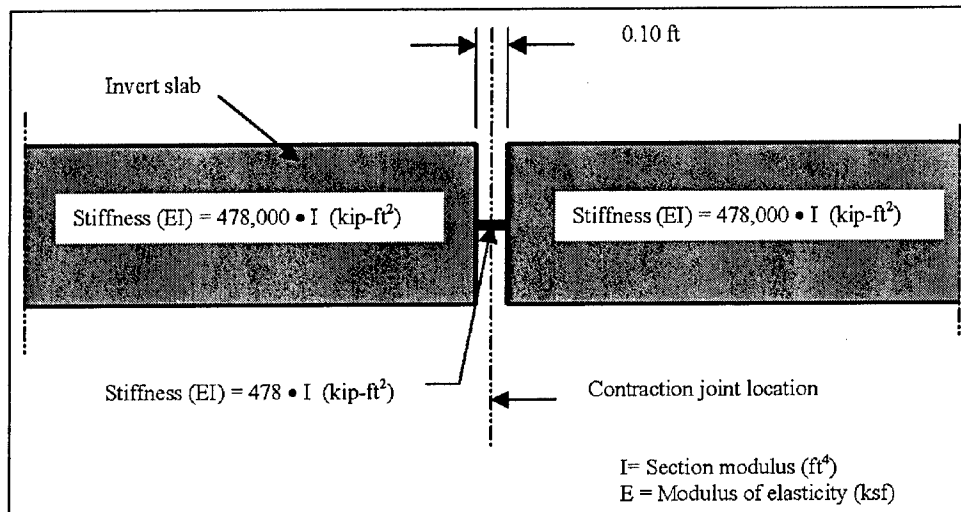

Figure 4-3. Invert slab contraction joint stiffness model

5 Invert Slab Limit-State Capacity

5.1 Interaction Diagrams

Interaction diagrams describing the capacity of reinforced and unreinforced concrete sections subjected to combined bending and axial load are common in strength design and limit-state capacity evaluation. Short column interaction diagrams (i.e., strength unreduced by second-order deformation effects) are provided herein for those minimum invert slab sections founded on rock and earth. Due to the positive eccentricity of the spillway wall loading, the invert slab bends upward at the cold joint where the spillway wall abuts the invert slab (Figure 3-1a). Since the primary slab reinforcement is in the top face, the flexural capacity benefits from reinforcing steel in tension are either nonexistent or less than that of the concrete in tension. Simple interaction diagrams are provided for reinforced concrete invert slab sections for those conditions where tension might occur in the top face. This is done only to illustrate construction of a reinforced concrete interaction diagram. Reinforced concrete interaction diagrams (tension in top face conditions) are constructed based on ACI 318 ultimate strength requirements (ACI 2002) assuming specified strain-strain relationships for pure axial load, pure bending, and balance point bending and axial load. Controlling strain conditions for each of the three aforementioned interaction diagram control points are illustrated in Figure 5-1a.

The strength interaction diagrams for unreinforced concrete are based on ultimate compressive and tensile stresses. These stress-based strength interaction diagrams are used in the report to determine the limit-state axial load capacity for flexural conditions that cause tension in the bottom face of the invert slab. Unreinforced concrete interaction diagrams are constructed based on ultimate compressive and tensile stress conditions for the same three points for reinforced concrete sections. Controlling stress conditions for each of the three interaction diagram control points as illustrated in Figure 5-1b.

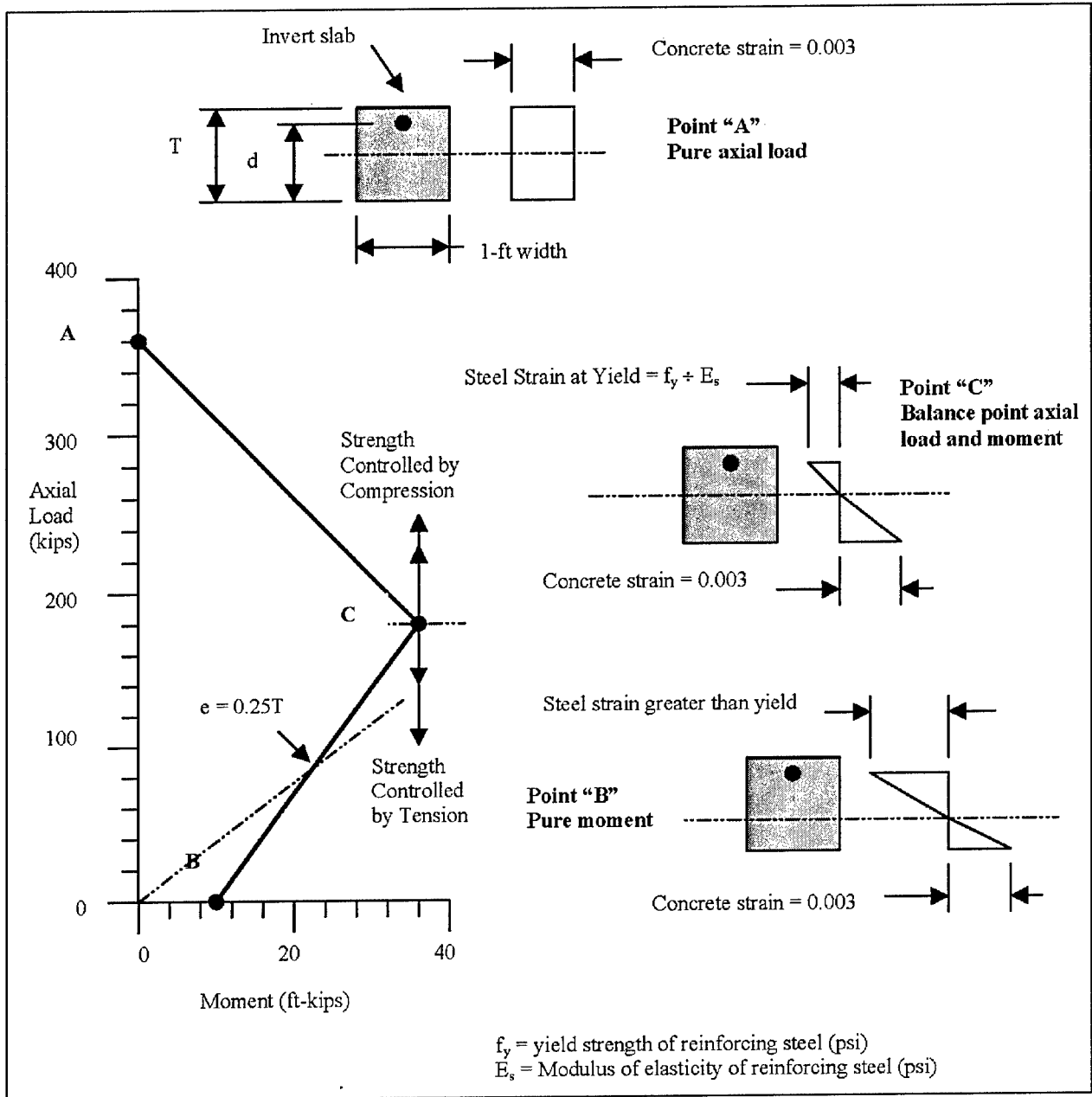

a. Reinforced concrete invert slab conditions

Figure 5-1. Invert slab interaction diagram construction (continued)

5.2 Invert Slabs on Rock

Short column interaction diagrams for minimum thickness invert slabs constructed on rock foundations (i.e., invert slabs with a 12-in. minimum thickness) are provided in Figure 5-2a for a reinforced section and in Figure 5-2c for an unreinforced section. Calculations used to construct the interaction diagrams are shown in Figures 5-2b and 5-2d.

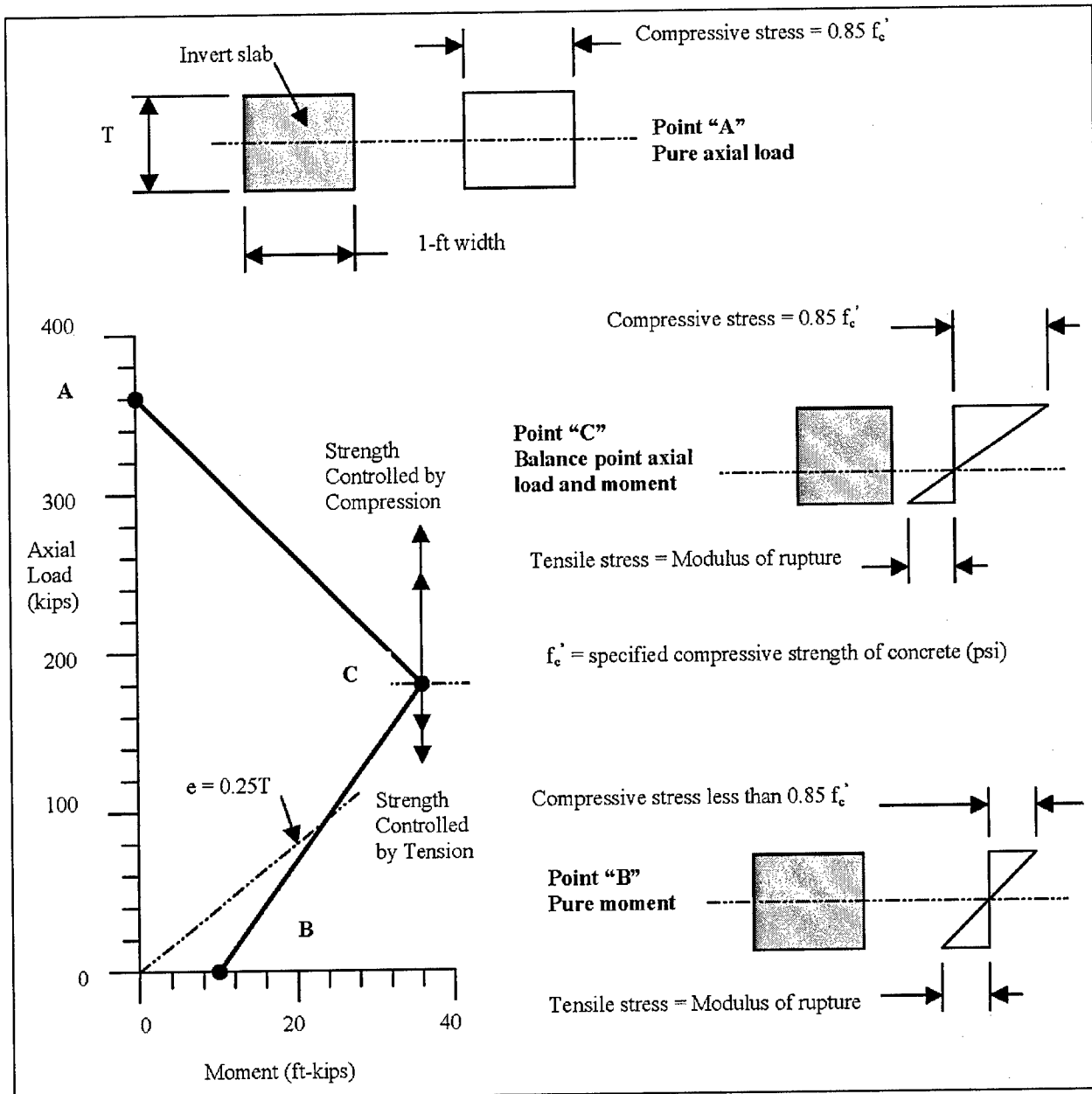

b. Unreinforced concrete invert slab conditions

Figure 5-1. (concluded)

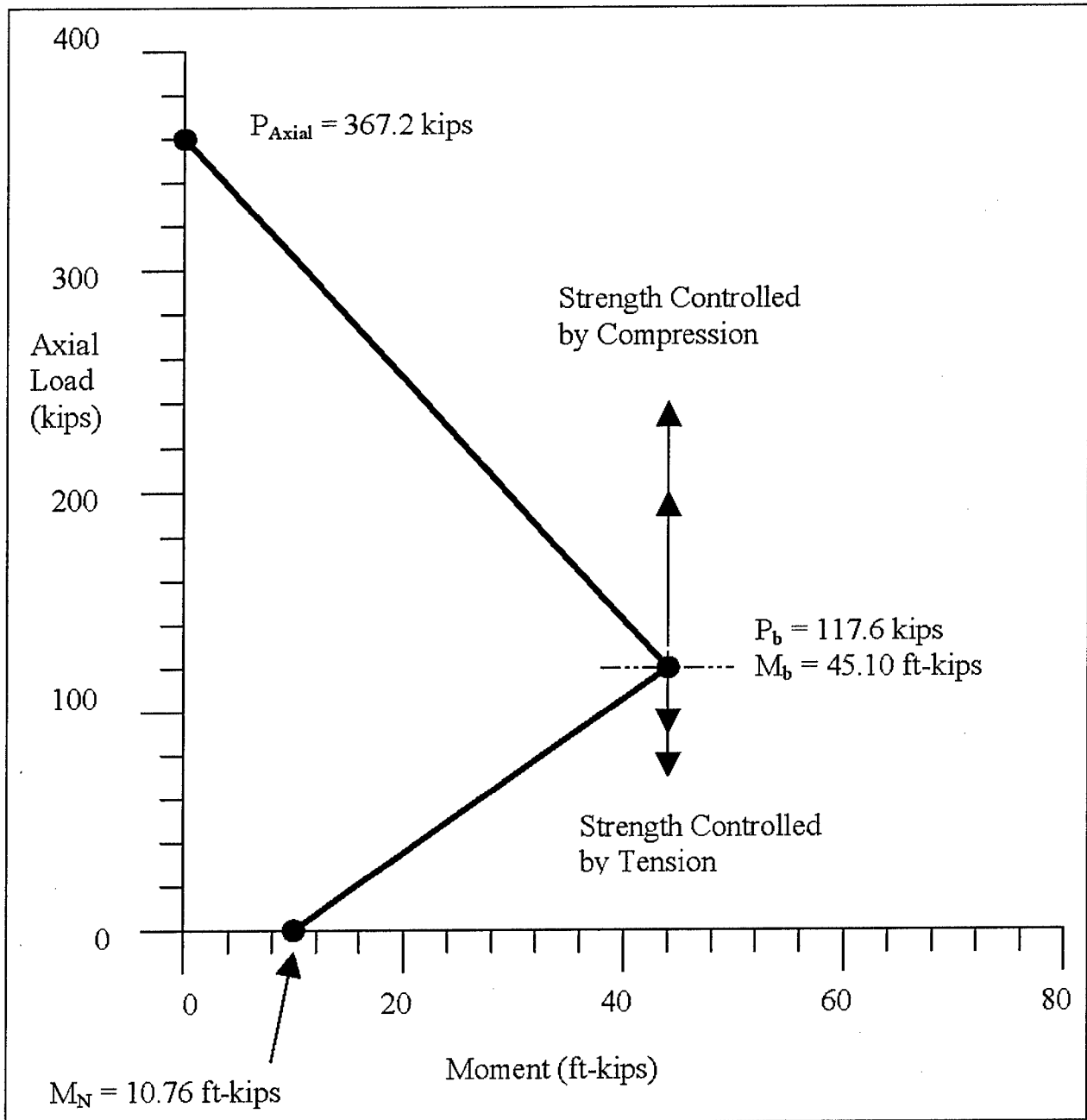

a. Reinforced concrete, 12-in.-thick slab on rock

Figure 5-2. Interaction diagrams and supporting calculations for invert slabs on rock (Sheet 1 of 5)

Develop Simplified Interaction Diagram for Invert Slab

Reinforced Concrete - Tension in Top Face Condition**Pure Axial Load** $b := 12 \text{ in}$ $t := 12 \text{ in}$ $f_c := 3000 \text{ psi}$

$$P_{\text{axial}} := 0.85 \cdot b \cdot t \cdot f_c \quad P_{\text{axial}} = 3.67210^5 \text{ lbf} \quad 367.2 \text{ kips}$$

Pure Bending $d_b := 0.75 \text{ in}$ $\text{cover} := 4 \text{ in}$ $A_s := 0.44 \text{ in}^2$

$$d := t - \text{cover} - \frac{d_b}{2} \quad d = 7.625 \text{ in} \quad f_y := 40000 \text{ psi}$$

$$M_N := \frac{A_s \cdot f_y}{b} \left[d - \frac{(A_s \cdot f_y)}{1.7 \cdot f_c \cdot b} \right] \quad M_N = 1.07610^4 \text{ lbf} \cdot \frac{\text{ft}}{\text{ft}} \quad 10.76 \text{ ft-kips}$$

Balanced Conditions

$$\varepsilon_c := 0.003 \quad \varepsilon_s := 0.0014 \quad N_A := \left(\frac{\varepsilon_c}{\varepsilon_c + \varepsilon_s} \right) \cdot d \quad N_A = 5.199 \text{ in}$$

Compression in concrete

$$a := 0.85 N_A \quad a = 4.419 \text{ in} \quad C_c := 0.85 f_c \cdot a \cdot b \quad C_c = 1.35210^5 \text{ lbf}$$

Tension in steel

$$T_s := A_s \cdot f_y \quad T_s = 1.7610^4 \text{ lbf}$$

Balance Point Axial Load

$$P_b := C_c - T_s \quad P_b = 1.17610^5 \text{ lbf} \quad 117.6 \text{ kips}$$

Balance Point Moment (Σ Moments about tension steel)

$$M_b := C_c \cdot \left(d - \frac{a}{2} \right) - P_b \cdot \left(d - \frac{t}{2} \right) \quad M_b = 4.51 \cdot 10^4 \text{ ft} \cdot \text{lbf} \quad 45.10 \text{ ft-kips}$$

Or taking moments about the centerline

$$M_b := C_c \cdot \left(\frac{t}{2} - \frac{a}{2} \right) + T_s \cdot \left(d - \frac{t}{2} \right) \quad M_b = 4.51 \cdot 10^4 \text{ ft} \cdot \text{lbf}$$

b. Mathcad calculations for Figure 5-2a

Figure 5-2 (Sheet 2 of 5)

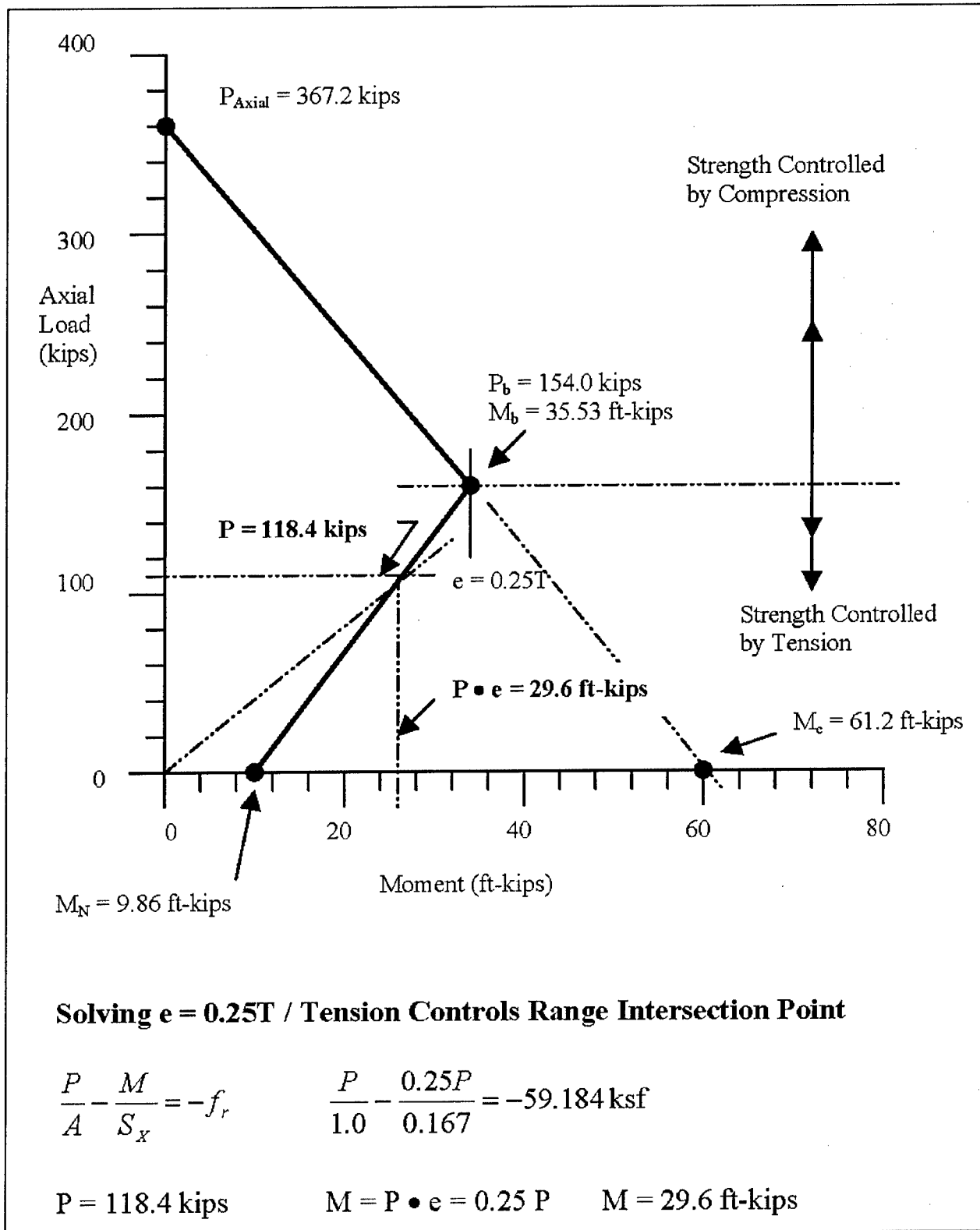

c. Unreinforced concrete, 12-in.-thick slab on rock

Figure 5-2. (Sheet 3 of 5)

Unreinforced Concrete

Pure Axial Load $b := 12 \cdot \text{in}$ $t := 12 \cdot \text{in}$ $f_c := 3000 \cdot \text{psi}$

$P_{\text{axial}} := 0.85 \cdot b \cdot t \cdot f_c$ $P_{\text{axial}} = 3.672 \cdot 10^5 \cdot \text{lbf}$ 367.2 kips

Pure Bending

$f_c := 3000$ psi

Modulus of Rupture $f_r := 7.5 \cdot \sqrt{f_c}$ $f_r = 410.792$ psi

$f_c := 3000 \cdot \text{psi}$ $f_r := 411 \cdot \text{psi}$

$S_x := \left(\frac{1}{6}\right) \cdot b \cdot t^2$ $S_x = 288 \cdot \text{in}^3$ $S_x = 0.167 \cdot \text{ft}^3$

$M := S_x \cdot f_r$ $M = 9.864 \cdot 10^3 \cdot \text{ft} \cdot \text{lbf}$ 9.86 ft-kips

Fictitious Pure Bending Compressive Stress Controls Point

$M_c := 0.85 \cdot f_c \cdot S_x$ $M_c = 6.12 \cdot 10^4 \cdot \text{ft} \cdot \text{lbf}$ 61.2 ft-kips

Equation 1

$$\frac{P_B}{P_A} + \frac{M_B}{M_C} = 1 \qquad \frac{P_B}{367.2} + \frac{M_B}{61.2} = 1 \qquad P_B + 6M_B = 367.2$$

Equation 2

$$\frac{P_B}{A} - \frac{M_B}{S_x} = -59.184 \qquad \frac{P_B}{1} - \frac{M_B}{0.167} = -59.184 \qquad P_B - 6M_B = -59.184$$

Solving Equations 1 and 2 Simultaneously

$P_B = 154$ Kips $M_B = 35.53$ Ft-Kips

d. Mathcad calculations for Figure 5-2c

Figure 5-2 (Sheet 4 of 5)

A	=	Cross-sectional area of section (unreinforced concrete)
f_r	=	Modulus of rupture of concrete (unreinforced concrete)
P	=	Axial load capacity at specified eccentricity of axial load (reinforced and unreinforced concrete)
P_{Axial}	=	Axial load capacity when concentrically loaded (reinforced and unreinforced concrete)
P_b	=	Balance point axial load capacity at simultaneous crushing of concrete and yielding of steel (reinforced concrete), or at the condition where compressive stress is at $0.85 f_c$ and the tensile stress is at the modulus of rupture (unreinforced concrete)
M_b	=	Balance point moment capacity at simultaneous crushing of concrete and yielding of steel (reinforced concrete), or at the condition where compressive stress is at $0.85 f_c$ and the tensile stress is at the modulus of rupture (unreinforced concrete)
M_N	=	Pure moment capacity of section (reinforced and unreinforced concrete)
M	=	Flexural capacity at specified eccentricity of axial load (reinforced and unreinforced concrete)
M_C	=	Fictitious pure moment capacity of section for compression controls condition (unreinforced concrete)
S_x	=	Section modulus of concrete section (unreinforced concrete)

e. Definition of terms

Figure 5-2. (Sheet 5 of 5)

5.3 Invert Slabs on Earth

Short column interaction diagrams for minimum thickness invert slabs constructed on earth foundations (i.e., invert slabs with a 24-in. minimum thickness) are provided in Figure 5-3a for a reinforced section, and in Figure 5-3c for an unreinforced section. Calculations used to construct the interaction diagrams are shown in Figures 5-3b and 5-3d.

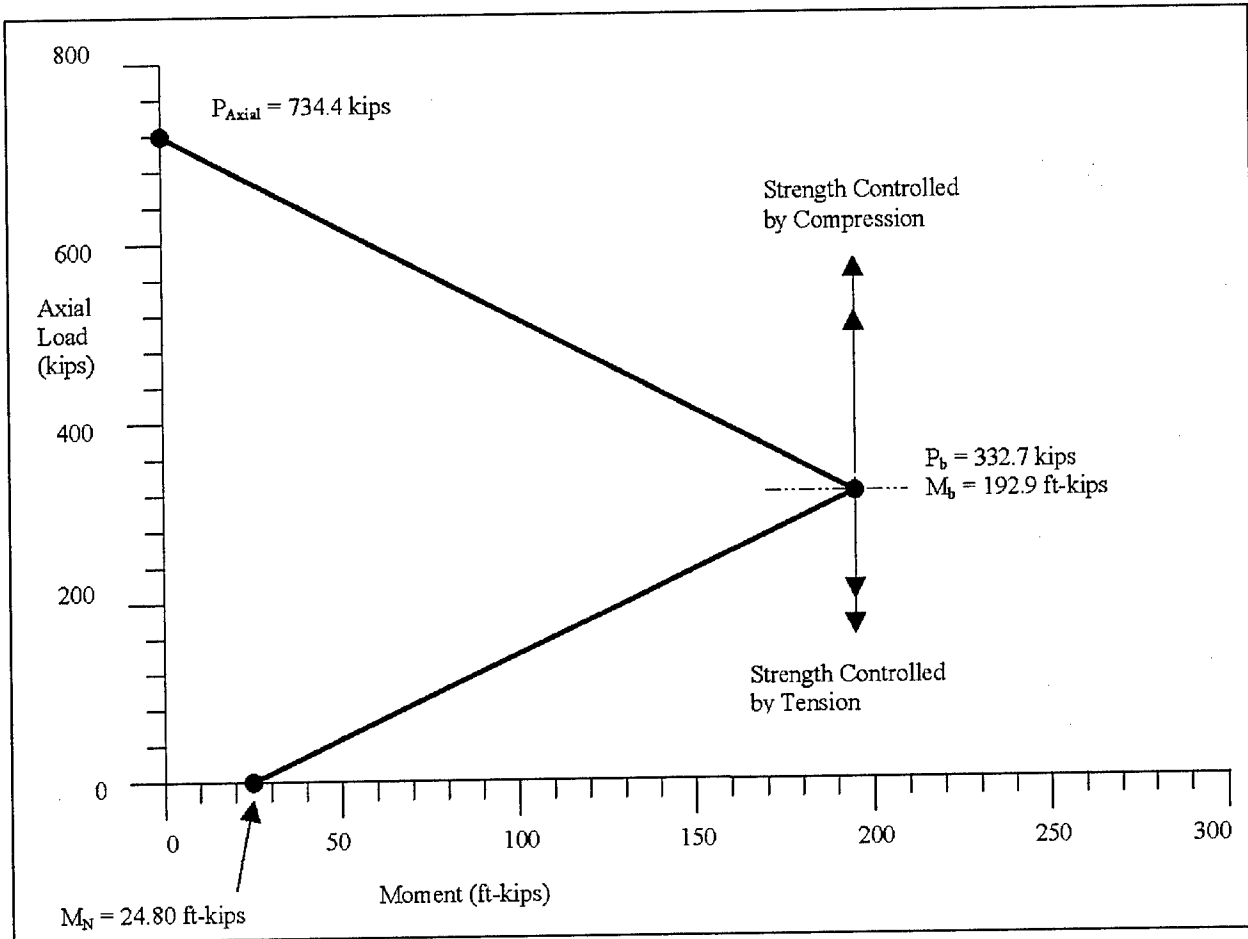

a. Reinforced concrete, 24-in.-thick slab on earth

Figure 5-3. Interaction diagrams and supporting calculations for invert slabs on earth (see Figure 5-2e for definition of terms) (Sheet 1 of 4)

Develop Simplified Interaction Diagram for Invert Slab

Reinforced Concrete - Tension in Top Face Condition**Pure Axial Load** $b := 12 \cdot \text{in}$ $t := 24 \cdot \text{in}$ $f_c := 3000 \cdot \text{psi}$

$$P_{\text{axial}} := 0.85 \cdot b \cdot t \cdot f_c \quad P_{\text{axial}} = 7.344 \cdot 10^5 \cdot \text{lb} \cdot \text{f} \quad 734.4 \text{ kips}$$

Pure Bending $d_b := 0.75 \cdot \text{in}$ $\text{cover} := 4 \cdot \text{in}$ $A_s := 0.384 \cdot \text{in}^2$

$$d := t - \text{cover} - \frac{d_b}{2} \quad d = 19.625 \cdot \text{in} \quad f_y := 40000 \cdot \text{psi}$$

$$M_N := \frac{A_s \cdot f_y}{b} \left[d - \frac{(A_s \cdot f_y)}{1.7 \cdot f_c \cdot b} \right] \quad M_N = 2.48 \cdot 10^4 \cdot \text{lb} \cdot \frac{\text{ft}}{\text{ft}} \quad 24.80 \text{ ft-kips}$$

Balanced Conditions

$$\varepsilon_c := 0.003 \quad \varepsilon_s := 0.0014 \quad N_A := \left(\frac{\varepsilon_c}{\varepsilon_c + \varepsilon_s} \right) \cdot d \quad N_A = 13.381 \cdot \text{in}$$

Compression in concrete

$$a := 0.85 \cdot N_A \quad a = 11.374 \cdot \text{in} \quad C_c := 0.85 \cdot f_c \cdot a \cdot b \quad C_c = 3.48 \cdot 10^5 \cdot \text{lb} \cdot \text{f}$$

Tension in steel

$$T_s := A_s \cdot f_y \quad T_s = 1.536 \cdot 10^4 \cdot \text{lb} \cdot \text{f}$$

Balance Point Axial Load

$$P_b := C_c - T_s \quad P_b = 3.327 \cdot 10^5 \cdot \text{lb} \cdot \text{f} \quad 332.7 \text{ kips}$$

Balance Point Moment (Σ Moments about tension steel)

$$M_b := C_c \cdot \left(d - \frac{a}{2} \right) - P_b \cdot \left(d - \frac{t}{2} \right) \quad M_b = 1.929 \cdot 10^5 \cdot \text{ft} \cdot \text{lb} \cdot \text{f} \quad 192.9 \text{ ft-kips}$$

Or taking moments about the centerline

$$M_b := C_c \cdot \left(\frac{t}{2} - \frac{a}{2} \right) + T_s \cdot \left(d - \frac{t}{2} \right) \quad M_b = 1.929 \cdot 10^5 \cdot \text{ft} \cdot \text{lb} \cdot \text{f}$$

b. Mathcad calculations for Figure 5-3a

Figure 5-3. (Sheet 2 of 4)

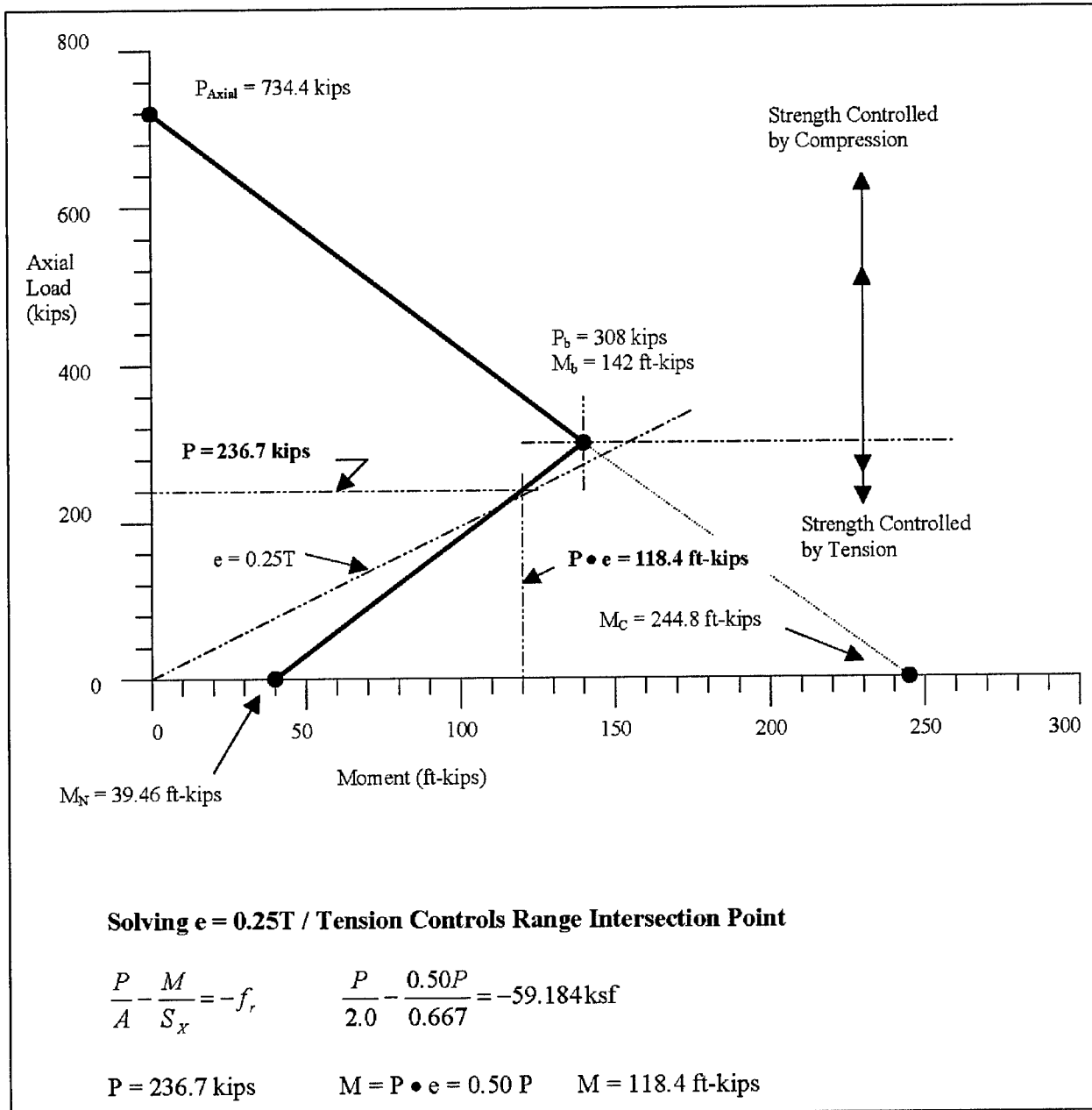

c. Unreinforced concrete, 24-in.-thick slab on earth

Figure 5-3. (Sheet 3 of 4)

Unreinforced Concrete

Pure Axial Load $b := 12 \cdot \text{in}$ $t := 24 \cdot \text{in}$ $f_c := 3000 \cdot \text{psi}$

$P_{\text{axial}} := 0.85 \cdot b \cdot t \cdot f_c$ $P_{\text{axial}} = 7.344 \cdot 10^5 \cdot \text{lb}$ 734.4 kips

Pure Bending

$f_c := 3000$ psi

Modulus of Rupture $f_r := 7.5 \cdot \sqrt{f_c}$ $f_r = 410.792$ psi

$f_c := 3000 \cdot \text{psi}$ $f_r := 411 \cdot \text{psi}$

$S_x := \left(\frac{1}{6}\right) \cdot b \cdot t^2$ $S_x = 1.152 \cdot 10^3 \cdot \text{in}^3$ $S_x = 0.667 \cdot \text{ft}^3$

$M := S_x \cdot f_r$ $M = 3.946 \cdot 10^4 \cdot \text{ft} \cdot \text{lb}$ 39.46 ft-kips

Fictitious Pure Bending Compressive Stress Controls Point

$M_c := 0.85 \cdot f_c \cdot S_x$ $M_c = 2.448 \cdot 10^5 \cdot \text{ft} \cdot \text{lb}$ 244.8 ft-kips

Equation 1

$$\frac{P_B}{P_A} + \frac{M_B}{M_C} = 1 \qquad \frac{P_B}{734.4} + \frac{M_B}{244.8} = 1 \qquad P_B + 3M_B = 734.4$$

Equation 2

$$\frac{P_B}{A} - \frac{M_B}{S_x} = -59.184 \qquad \frac{P_B}{2} - \frac{M_B}{0.667} = -59.184 \qquad P_B - 3M_B = -118.368$$

Solving Equations 1 and 2 Simultaneously

$P_B = 308$ Kips $M_B = 142$ Ft-Kips

d. Mathcad calculations for Figure 5-3c
Figure 5-3. (Sheet 4 of 4)

6 Assessing System Behavior

Short column interaction diagrams were developed previously for both cracked (reinforced) and uncracked (unreinforced) conditions. As indicated previously, uncracked conditions will govern since the eccentricity is positive, the reinforcement ratio is small, and most reinforcement will generally be located near the top of the invert slab where it is ineffective with respect to conditions where tension occurs in the bottom of the slab. Assuming a positive eccentricity equal to $0.25T$, the short column capacity was determined (Figures 5-2c and 5-3c). Since the short column capacity is assumed to be the maximum capacity of the invert slab, its associated axial load and moment will be applied to each end of the invert slab to assess invert slab behavior under the assumed limit-state conditions. The compression force representing the axial load is applied assuming a perfectly plastic interface pressure distribution (i.e., rectangular stress block). The invert slab behavior (i.e., displacements, moments, and bearing pressures) will be determined by a beam on nonlinear springs analysis using the Corps computer program CBEAMC. Foundation springs are as previously determined for rock and earth foundation conditions for Class C site conditions. Analyses are performed for a 1-ft-thick slab on rock and a 2-ft-thick slab on earth for both continuous reinforcing plan conditions and independent block plan conditions. A 1-ft width of slab is used for each analysis.

Preliminary analyses indicate invert slab behavior for earth foundation conditions will be similar to that shown on Figure 6-1.

Based on preliminary analyses it can be assumed that due to the eccentricity of the axial load the invert slab will attempt to lift off the foundation in a limited region adjacent to the spillway wall.

For rock foundations the extent of this lift-off region will depend on the direct tensile capacity along the slab-foundation interface. However a lift-off region will not exist for conditions where tensile demands on the interface region are less than the tensile capacity of the interface. Rock anchors used to resist uplift provide additional lift-off resistance. For the analyses contained in this report the tensile capacity of the interface was determined to provide adequate lift-off resistance without any contribution from rock anchors. This assumes the rock foundations are competent without significant joints, faults, or bedding planes that could prevent bonding between the invert slab and rock foundation system and allow for tension transfer through the foundation.

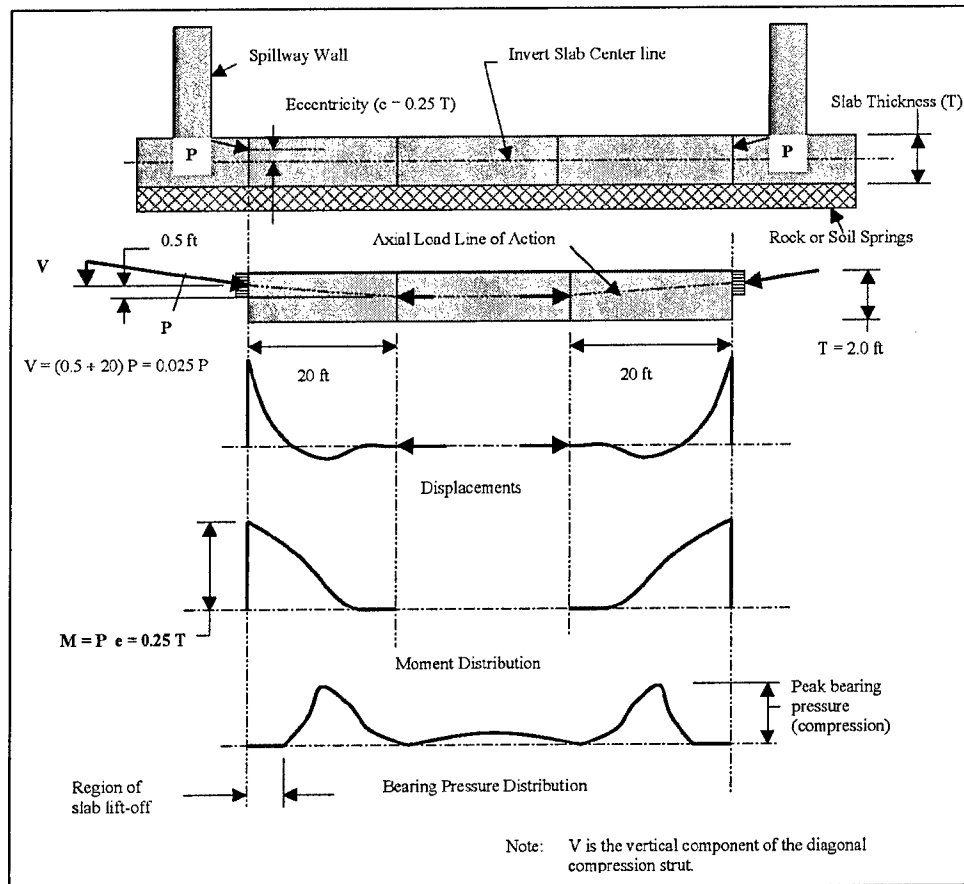

Figure 6-1. Line of action, 60-ft-wide invert slab, positive eccentricity = 0.25 T

For earth foundations the extent of this lift-off region is sensitive to the vertical component of a diagonal compression strut acting between the ends of the effective column section. The larger the vertical component, the smaller the lift-off region. The compression strut line of action is illustrated in Figure 6-1. The enhancement to lift-off resistance provided by the vertical component of a diagonal compression strut is adopted for the invert slab problem based on research described in Priestley, Verma, and Xaio (1984). This research demonstrates that column shear resistance is enhanced by the lateral component of an inclined compression strut acting along a line joining the centers of end region compressive stress blocks. This concept had been applied to the invert slab problem assuming the following:

- a. With respect to the slab section, the stress block center is located a distance of $0.25T$ from the slab center line at the end of the slab where the axial load is applied, or at the end where the slab abuts the retaining wall footing. This is per previously described end eccentricity assumptions.
- b. With respect to the slab section, the stress block center is assumed to be coincident with the slab center line at a specified point of fixity. The point of fixity will be at the point of zero slab rotation.

For earth foundation (site Class C) conditions, the CBEAMC analysis indicates an “effective” invert slab length of 14 ft (i.e., the distance between where the axial load is applied and point of fixity as described). The “effective” length is for convenience selected as the length of invert slab that can be replaced by an equivalent cantilever beam spanning between the wall-invert slab end (considered to be the free end) and the point of zero rotation end (considered to be the fixed end). To err on the side of conservatism a 20-ft effective length was selected. This was used with a “free end” eccentricity of 0.5 ft (eccentricity of $0.25T$ for a 2-ft-thick slab). Based on the aforementioned stress block assumptions the vertical component of the inclined compression strut is equal to $0.5 \div 20$, or 0.025 times the axial load P . This component force is included in the CBEAMC analyses for invert slabs founded on earth foundations.

The invert slab thicknesses selected for the CBEAMC analyses are a minimum for rock and earth foundation conditions. The resulting invert slab behavior will be reviewed to determine if slab moments could be amplified due to $P \cdot \Delta$ effects (i.e., second-order deformation effects). If moment magnification is possible, an analysis that considers second-order deformations will be performed.

6.1 Continuous Reinforcing Plan

Invert slab on nonlinear supports analysis results are provided in Figure 6-2 for the rock foundation and in Figure 6-3 for the earth foundation.

The rock foundation results indicate the tensile capacity at the rock-invert slab interface is adequate to prevent slab lift-off. Since continuous support against second-order displacement is provided by the rock (i.e., analogous to providing continuous lateral support to columns), short column behavior can be assumed. Therefore the limit-state axial capacity of invert slabs founded on rock can be based on short column interaction.

The earth foundation results indicate that slab lift-off is possible in a region immediately adjacent to the spillway wall footing. Therefore second-order effects should be considered. A second-order displacement effects analysis was performed for the independent block plan on earth foundation. The results, presented in the following section, indicate that the moment magnification due to second-order displacements will not reduce the limit-state axial load capacity determined using an appropriate short column interaction diagram. These results are also applicable to the continuous reinforcing plan on earth foundation.

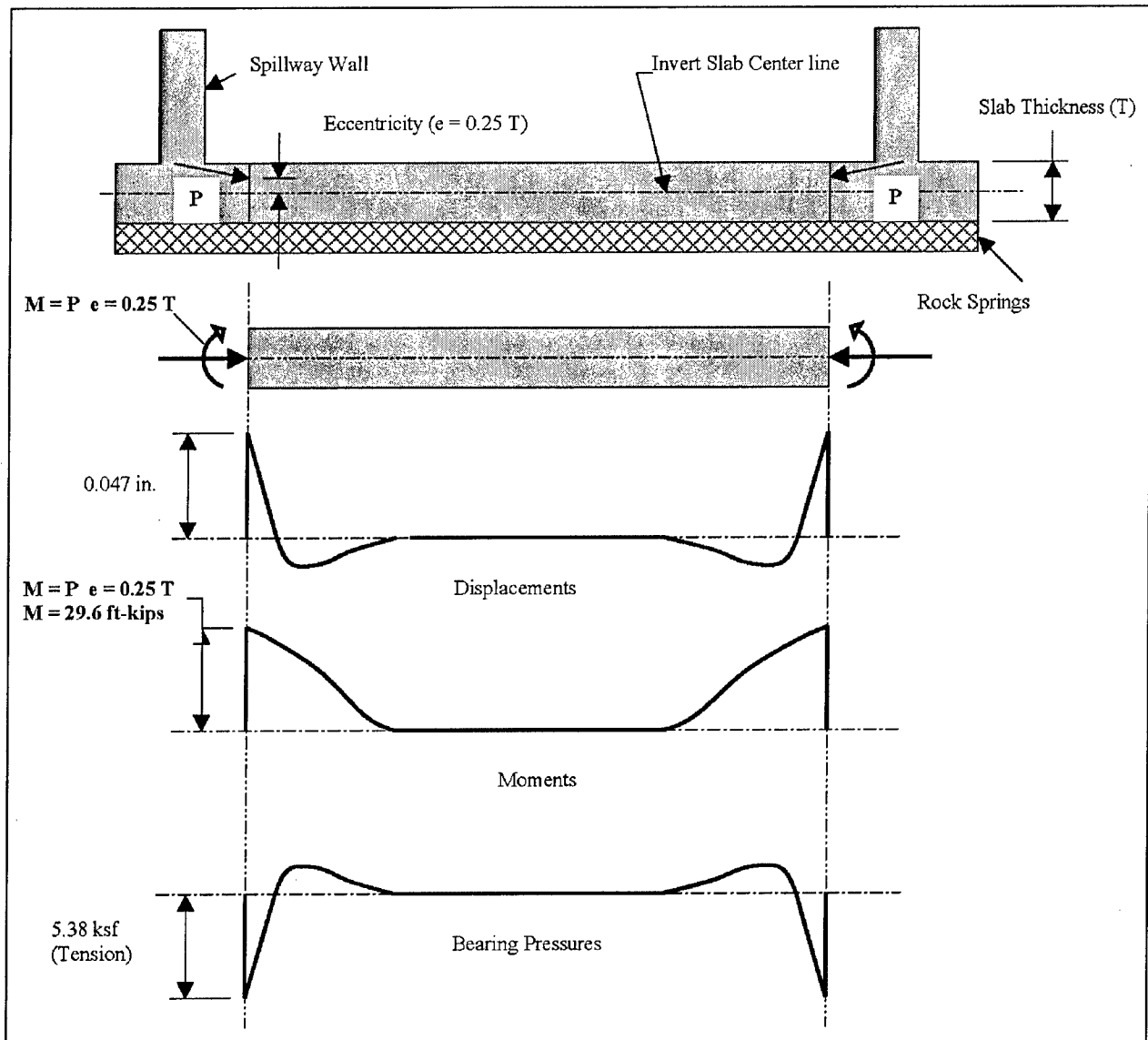

Figure 6-2. Continuous reinforcing plan, rock foundation, 60-ft-wide invert slab, Class C site, positive eccentricity = $0.25 T$

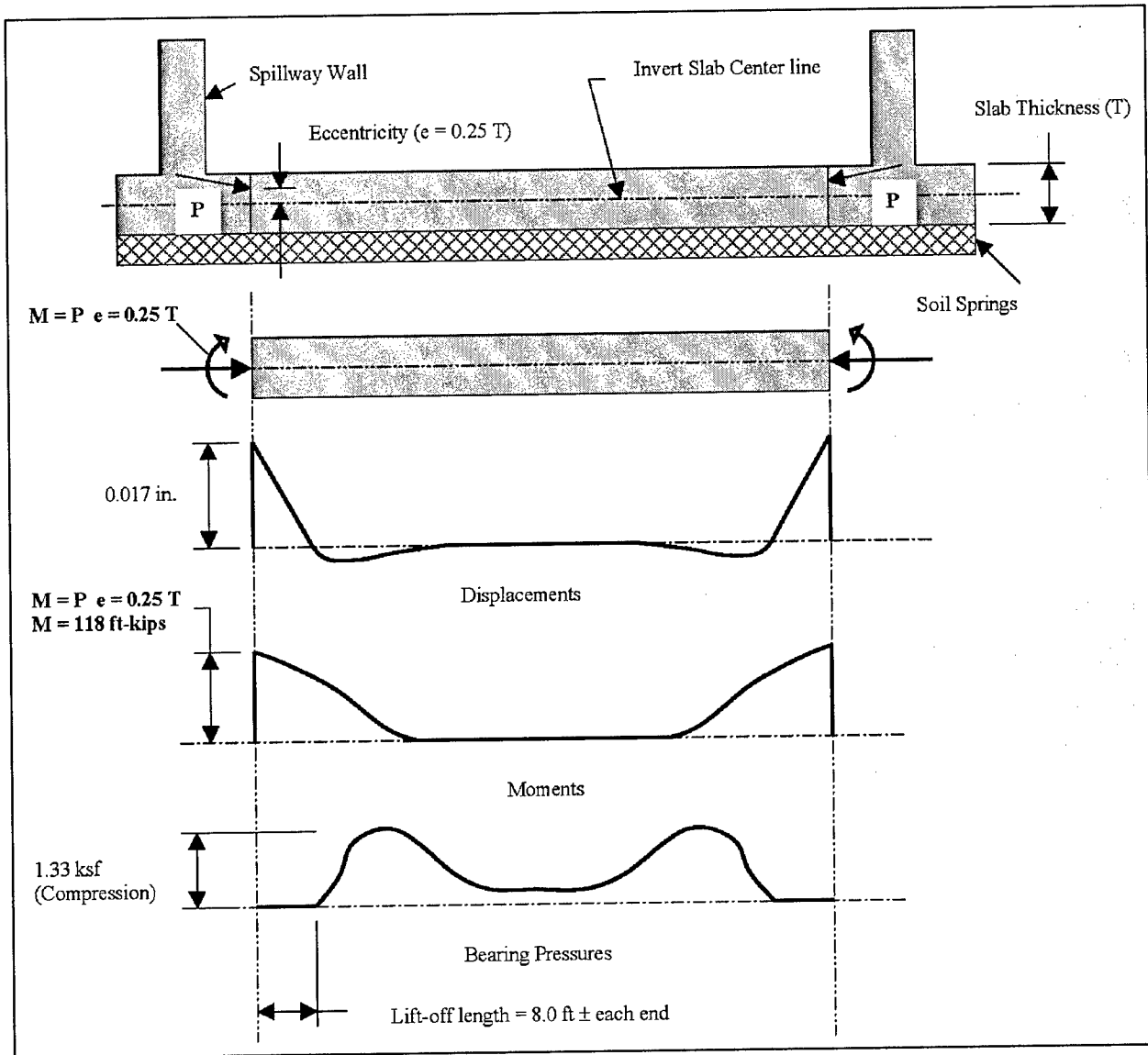

Figure 6-3. Continuous reinforcing plan, earth foundation, 60-ft-wide invert slab, Class C site, positive eccentricity = $0.25 T$

6.2 Independent Block Plan

Invert slab on nonlinear supports analysis results are provided in Figure 6-4 for the rock foundation and in Figure 6-5 for the earth foundation.

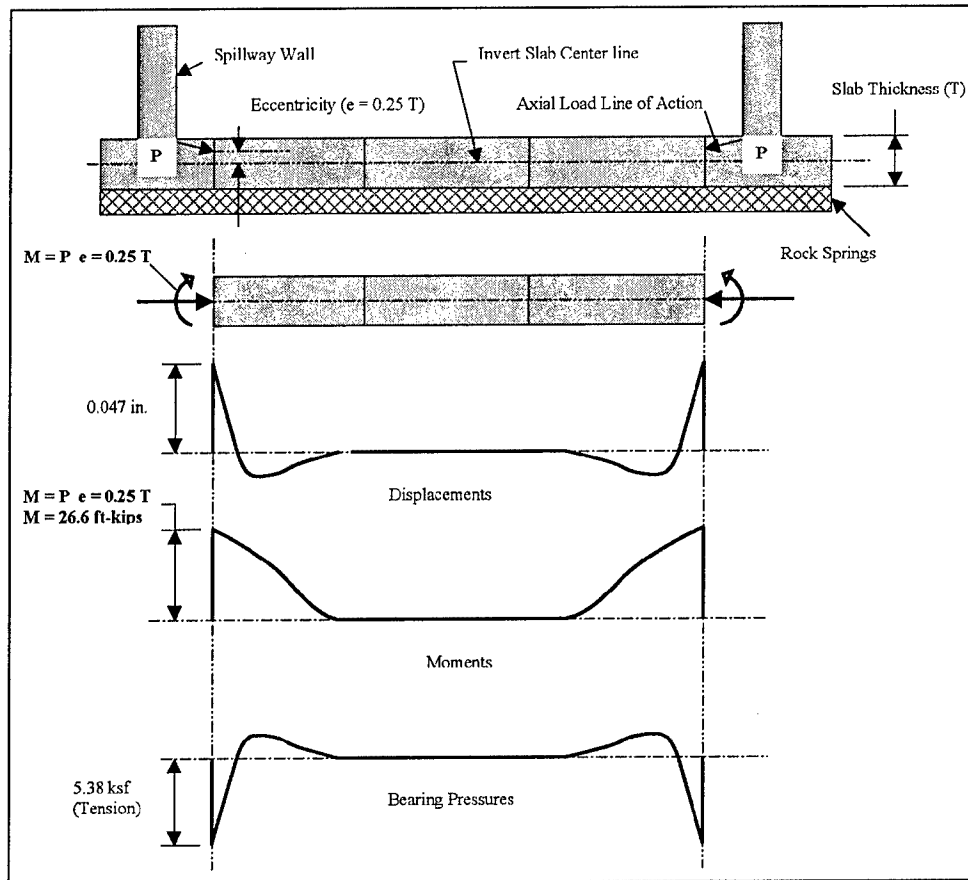

Figure 6-4. Independent block plan, rock foundation, 60-ft-wide invert slab, Class C site, positive eccentricity = 0.25 T

As with the continuous reinforcing plan, the rock foundation results indicate that the tensile capacity at the rock-invert slab interface is adequate to prevent slab lift-off, and the limit-state axial capacity can be based on short column interaction. Again, the analytical behavior captured for rock-founded invert slab systems assumes the rock foundations are competent (i.e., without significant joints, faults, or bedding planes that could prevent bonding between the invert slab and rock foundation system and allow for tension transfer through the foundation).

Figures 6-2, 6-3, 6-4, and 6-5 represent invert slab behavior for Class C site conditions. The hard rock site (Class A) performed in a similar fashion with respect to displacements, moments, and bearing pressure distributions. The stiff soil site (Class D) is considerably softer since a shear wave velocity of 600 fps was assumed for this particular site classification. Class D site performance is illustrated in Figure 6-6 for the independent block plan.

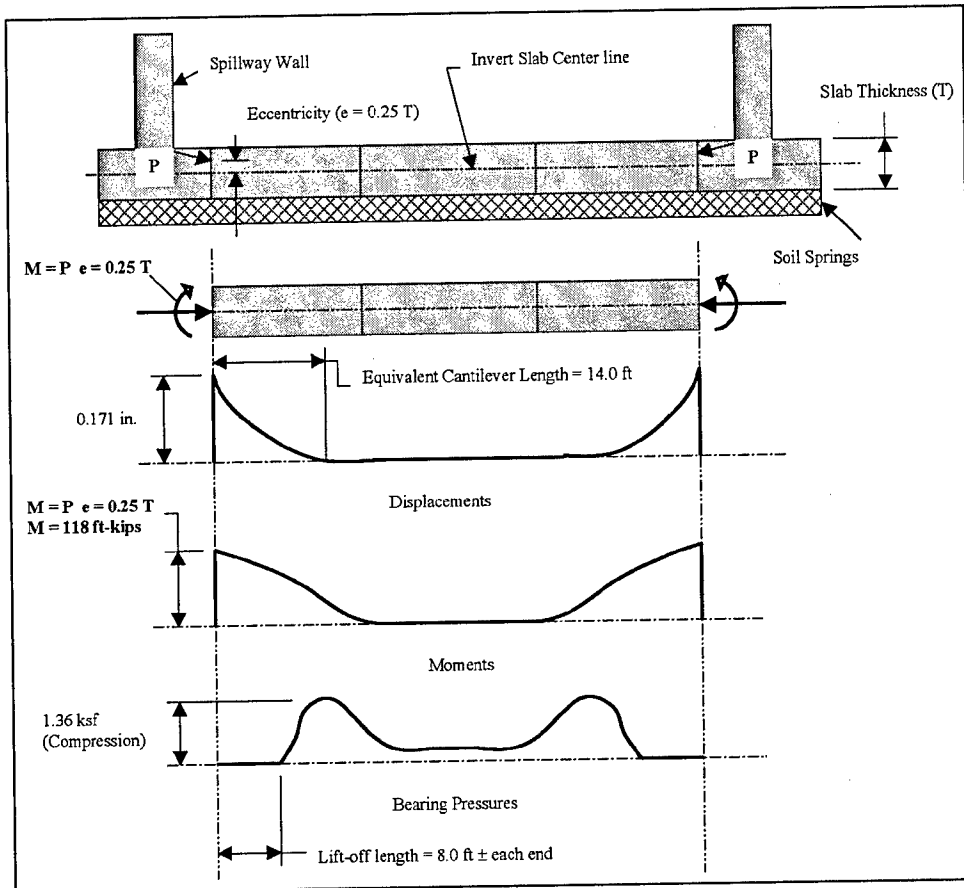

Figure 6-5. Independent block plan, earth foundation, 60-ft-wide invert slab, Class C site, positive eccentricity = $0.25 T$

It can be seen from Figure 6-6 that for the softer site the slab lift-off region is shorter and there is a more uniform distribution of bearing pressures. Results given in Figure 6-6 for an invert slab on a Class D earth foundation indicate a maximum bearing pressure of 0.761 ksf. The results from this particular analysis indicate that the usual dead load bearing pressures (0.300 ksf) increase only a small amount due to pseudo-static earthquake demands that have a potential to develop the limit-state axial load capacity of the invert slab. The increase in bearing pressure is attributed to end moments resulting from the specified positive eccentricity of the axial load. A check of the bearing pressure demands against allowable bearing pressures prescribed for a Class D earth foundation has not been provided as part of this analysis. The authors of this report assume that a site-specific check of the earth foundation bearing capacity has been conducted by the design engineer and determined to be adequate for the earthquake design loading.

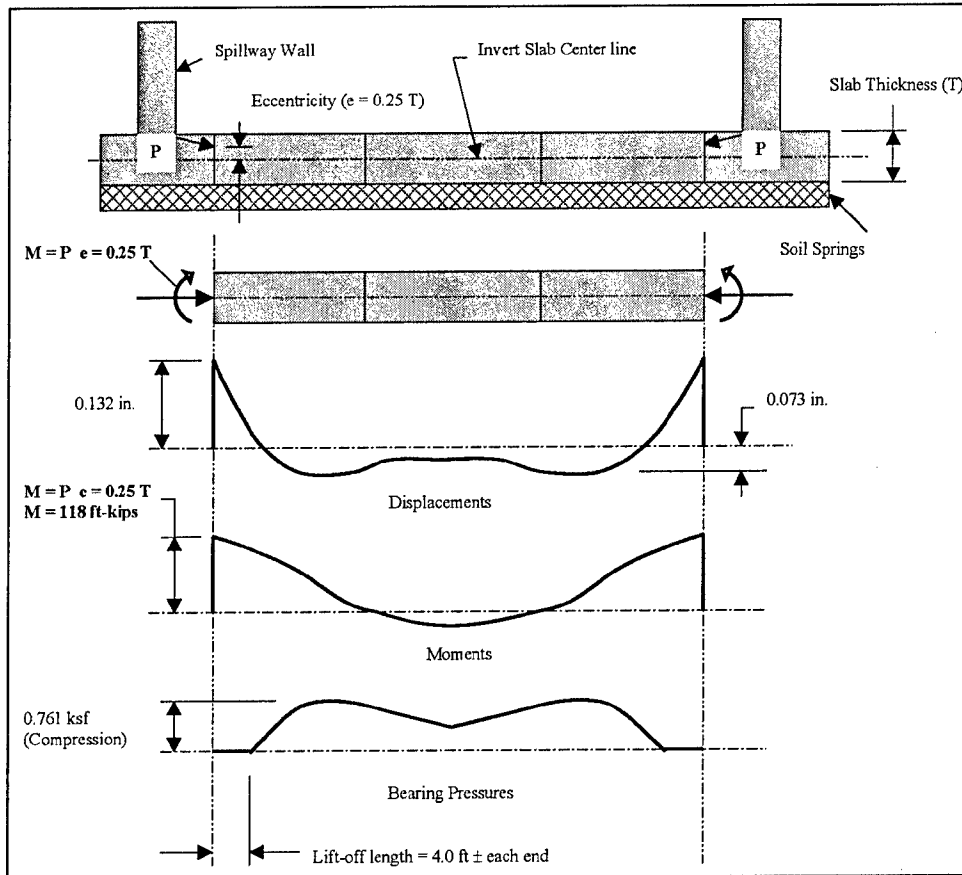

Figure 6-6. Independent block plan, earth foundation, 60-ft-wide invert slab, Class D site, positive eccentricity = 0.25 T

Results for the slab on earth foundation indicate that slab lift-off is possible in a region immediately adjacent to the spillway wall footing (see following CBEAMC analysis). Therefore, a second-order displacement effects analysis was performed. The second-order displacement analysis is presented in Chapter 7 for the independent block plan with the results illustrated in Figure 7-1. Results would be similar for the continuous reinforcing plan since the behavior of continuous reinforcing plan slab is similar to the independent block plan slab (Figures 6-3 and 6-5). The results to be discussed in Chapter 7 indicate that moment magnification due to second-order displacements is small and will not reduce the limit-state axial load capacity determined from the short column interaction diagram.

The input and output for an invert slab on nonlinear supports analysis (CBEAMC analysis) follows. This information represents the independent block plan on earth foundation for Class C site conditions.

CBEAMC INPUT FILE

```
'60 FOOT WIDE INVERT SLAB   FILE: IBP4  CJ AT 20 FEET EARTH FOUNDATION
'INDEPENDENT BLOCK PLAN POSITIVE ECCENTRICITY = 0.25T
BEAM  FT  KSF  FT
0     19.95  4.780E+05  2   0.667  2   0.667
19.95  20.05  4.780E+02  2   0.667  2   0.667
20.05  39.95  4.780E+05  2   0.667  2   0.667
39.95  40.05  4.780E+02  2   0.667  2   0.667
40.05  60.00  4.780E+05  2   0.667  2   0.667
NODES  FT  FT
0     60  2
LOADS  CONCENTRATED  FT  K  K-FT
0     0  -5.92  -118.4
59.95  0  -5.92  118.4
LOADS  DISTRIBUTED  FT  K/FT
0     0  -0.3  60  0  -0.3
FIXED  FT  FT
0     0.000  FREE  FREE
60    FREE  FREE  FREE
NONLINEAR DISTRIBUTED  FT  FT  K/F
Y  0  2  1  1
    -1  1385
    0  0
    60  2  1  1
    -1  1385
    0  0
FINISHED
```

CBEAMC OUTPUT FILE

PROGRAM CBEAMC - ANALYSIS OF BEAM-COLUMNS WITH NONLINEAR SUPPORTS

DATE: 20-JUNE-2003

TIME: 8:03:45

* SUMMARY OF RESULTS *

I.--HEADING

'60 FOOT WIDE INVERT SLAB FILE: IBP4 CJ AT 20 FEET EARTH FOUNDATION

'INDEPENDENT BLOCK PLAN POSITIVE ECCENTRICITY = 0.25T

II.--MAXIMA

	MAXIMUM POSITIVE	X-COORD (FT)	MAXIMUM NEGATIVE	X-COORD (FT)
AXIAL DISPLACEMENT (IN)	: 0.000E+00	0.00	0.000E+00	0.00
LATERAL DISPLACEMENT (IN)	: 1.712E-01	60.00	-1.179E-02	46.02
ROTATION (RAD)	: 2.965E-03	59.95	-2.970E-03	0.00
AXIAL FORCE (K)	: 0.000E+00	0.00	0.000E+00	0.00
SHEAR FORCE (K)	: 8.693E+00	50.00	-8.683E+00	9.98
BENDING MOMENT (K-FT)	: 1.184E+02	0.00	-1.657E+00	35.97

PROGRAM CBEAMC - ANALYSIS OF BEAM-COLUMNS WITH NONLINEAR SUPPORTS

DATE: 20-JUNE-2003

TIME: 8:03:45

* COMPLETE RESULTS *

I.--HEADING

'60 FOOT WIDE INVERT SLAB FILE: IBP4 CJ AT 20 FEET EARTH FOUNDATION

'INDEPENDENT BLOCK PLAN POSITIVE ECCENTRICITY = 0.25T

II.--DISPLACEMENTS AND INTERNAL FORCES

<-----DISPLACEMENTS----->			<-----INTERNAL FORCES----->		
X-COORD (FT)	LATERAL (IN)	ROTATION (RAD)	AXIAL (K)	SHEAR (K)	MOMENT (K-FT)
0.00	1.700E-01	-2.970E-03	0.000E+00	-5.920E+00	1.184E+02
2.00	1.075E-01	-2.267E-03	0.000E+00	-6.519E+00	1.060E+02
3.99	6.078E-02	-1.646E-03	0.000E+00	-7.117E+00	9.239E+01
5.99	2.793E-02	-1.114E-03	0.000E+00	-7.716E+00	7.760E+01
7.98	6.685E-03	-6.775E-04	0.000E+00	-8.314E+00	6.161E+01
9.98	-5.343E-03	-3.453E-04	0.000E+00	-8.683E+00	4.443E+01
11.97	-1.070E-02	-1.193E-04	0.000E+00	-7.331E+00	2.825E+01
13.97	-1.178E-02	1.586E-05	0.000E+00	-5.278E+00	1.564E+01
15.96	-1.047E-02	8.506E-05	0.000E+00	-3.283E+00	7.147E+00
17.96	-8.040E-03	1.128E-04	0.000E+00	-1.738E+00	2.232E+00
19.95	-5.245E-03	1.182E-04	0.000E+00	-8.046E-01	-1.972E-01
20.05	-5.145E-03	4.388E-05	0.000E+00	-7.747E-01	-2.761E-01
22.04	-4.150E-03	3.843E-05	0.000E+00	-3.068E-01	-1.314E+00
24.03	-3.341E-03	2.896E-05	0.000E+00	-4.782E-02	-1.636E+00
26.02	-2.772E-03	1.873E-05	0.000E+00	5.257E-02	-1.610E+00
28.01	-2.442E-03	9.040E-06	0.000E+00	4.996E-02	-1.495E+00
30.00	-2.336E-03	-7.798E-06	0.000E+00	-2.504E-03	-1.444E+00
31.99	-2.446E-03	-9.226E-06	0.000E+00	-5.453E-02	-1.505E+00
33.98	-2.782E-03	-1.900E-05	0.000E+00	-5.564E-02	-1.627E+00
35.97	-3.359E-03	-2.936E-05	0.000E+00	4.775E-02	-1.657E+00
37.96	-4.178E-03	-3.895E-05	0.000E+00	3.119E-01	-1.331E+00
39.95	-5.187E-03	-4.445E-05	0.000E+00	7.878E-01	-2.749E-01
40.05	-5.287E-03	-1.182E-04	0.000E+00	8.182E-01	-1.946E-01
42.04	-8.073E-03	-1.127E-04	0.000E+00	1.758E+00	2.262E+00
44.03	-1.049E-02	-8.472E-05	0.000E+00	3.306E+00	7.208E+00
46.02	-1.179E-02	-1.523E-05	0.000E+00	5.299E+00	1.572E+01
48.01	-1.069E-02	1.201E-04	0.000E+00	7.346E+00	2.834E+01
50.00	-5.329E-03	3.461E-04	0.000E+00	8.693E+00	4.450E+01
51.99	6.683E-03	6.778E-04	0.000E+00	8.323E+00	6.165E+01
53.98	2.787E-02	1.113E-03	0.000E+00	7.726E+00	7.762E+01
55.97	6.061E-02	1.644E-03	0.000E+00	7.129E+00	9.240E+01
57.96	1.071E-01	2.264E-03	0.000E+00	6.532E+00	1.060E+02
59.95	1.694E-01	2.965E-03	0.000E+00	5.935E+00	1.184E+02
59.95	1.694E-01	2.965E-03	0.000E+00	1.500E-02	-3.750E-04
60.00	1.712E-01	2.965E-03	0.000E+00	-1.482E-08	-1.964E-09

Point of zero rotation.
Used to establish the "effective"
slab length for the P • Δ analysis

IV.--FORCES IN NONLINEAR DISTRIBUTED SPRINGS

X-COORD (FT)	AXIAL (K/FT)	LATERAL (K/FT)
0.00	0.000E+00	0.000E+00
2.00	0.000E+00	0.000E+00
3.99	0.000E+00	0.000E+00
5.99	0.000E+00	0.000E+00
7.98	0.000E+00	0.000E+00
9.98	0.000E+00	6.167E-01
11.97	0.000E+00	1.235E+00
13.97	0.000E+00	1.360E+00
15.96	0.000E+00	1.208E+00
17.96	0.000E+00	9.280E-01
19.95	0.000E+00	6.054E-01
20.05	0.000E+00	5.939E-01
22.04	0.000E+00	4.790E-01
24.03	0.000E+00	3.856E-01
26.02	0.000E+00	3.200E-01
28.01	0.000E+00	2.819E-01
30.00	0.000E+00	2.696E-01
31.99	0.000E+00	2.823E-01
33.98	0.000E+00	3.210E-01
35.97	0.000E+00	3.876E-01
37.96	0.000E+00	4.822E-01
39.95	0.000E+00	5.987E-01
40.05	0.000E+00	6.102E-01
42.04	0.000E+00	9.318E-01
44.03	0.000E+00	1.211E+00
46.02	0.000E+00	1.361E+00
48.01	0.000E+00	1.234E+00
50.00	0.000E+00	6.151E-01
51.99	0.000E+00	0.000E+00
53.98	0.000E+00	0.000E+00
55.97	0.000E+00	0.000E+00
57.96	0.000E+00	0.000E+00
59.95	0.000E+00	0.000E+00
60.00	0.000E+00	0.000E+00

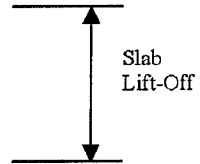
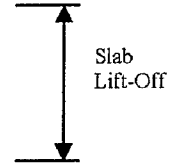

7 Second-order Deflection Effects

Using the deflected shape information from the preceding CBEAMC analysis, an equivalent invert slab cantilever section was selected for the second-order analysis. The equivalent cantilever section is assumed free to translate at the end adjacent to the spillway wall and assumed to be fixed at a point where the slope of the deflected shape is zero. This point occurs a distance of 14.0 ft from the free-to-translate end. (Note from the CBEAMC analysis that the rotation is equal to zero at $X = 14$ ft.) An axial load based on the short column interaction capacity at an eccentricity of $0.25T$, a moment due to axial load eccentricity, a vertical end force due to the vertical component of the diagonal compression strut, and slab dead load were all input as loads to the analysis. Analyses were performed using the SAP90 software (Wilson and Habibullah 1990) for the condition with no $P \cdot \Delta$ effects and the condition with $P \cdot \Delta$ effects. The input and output results for both conditions follow. Invert slab moments with and without $P \cdot \Delta$ effects for site Class C conditions are compared in Figure 7-1.

It can be seen from Figure 7-1 that moment magnifications due to $P \cdot \Delta$ effects are insignificant.

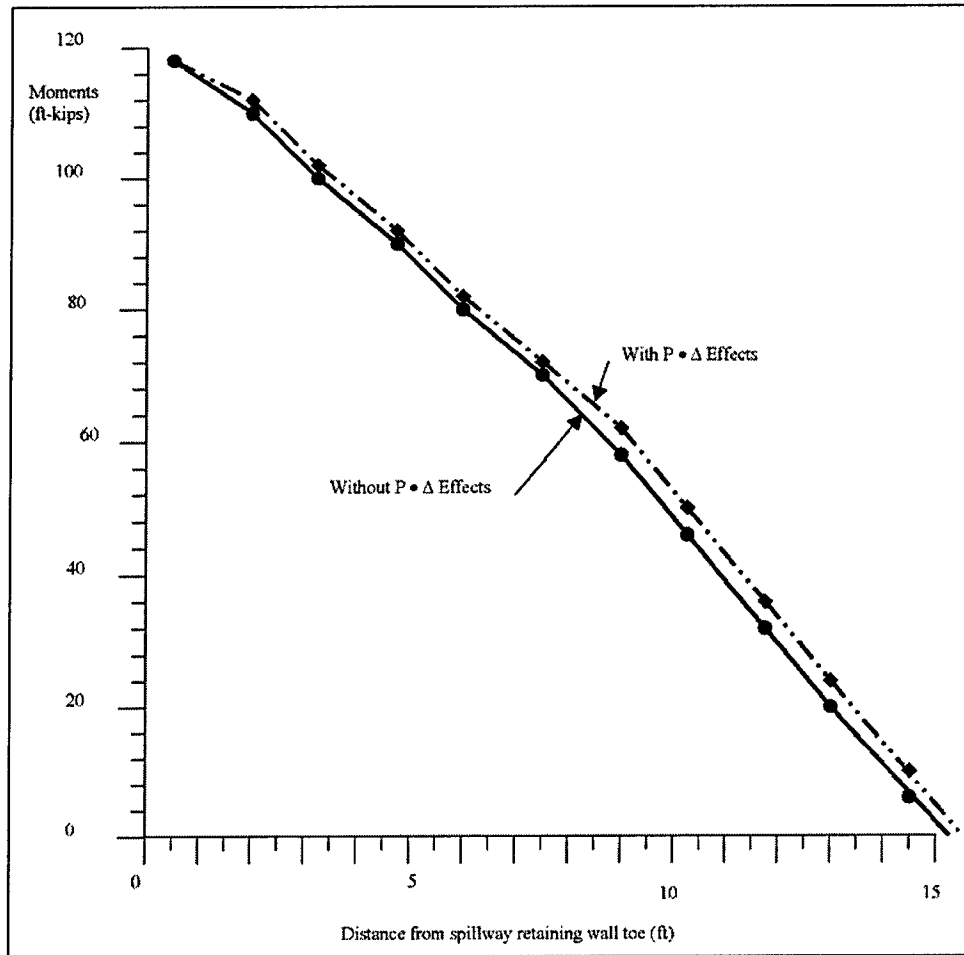

Figure 7-1. Independent block plan on earth, moment magnification effects

SAP90 INPUT FILE -- NO P • Δ EFFECTS

NPD4 - INVERT SLAB - 14 FOOT UNSUPPORTED LENGTH - NO P-DELTA EFFECTS
C ECCENTRICITY AT 0.25T
C AXIAL LOAD AT 236.7 KIPS
C EFFECTIVE CANTILEVER LENGTH = 14.0 FEET
C COMPRESSION STRUT SHEAR COMPONENT = 5.92 KIPS
C UNITS ARE KIPS FEET

SYSTEM
L=1

JOINTS
1 X=0 Y=0 Z=0
11 X=14 Y=0 Z=0 G=1,11,1

FRAME
NM=1 NL=1
1 SH=R T=2,1 E=478200
1 WG=0,-0.30
1 1 2 M=1 LP=1,0 NSL=1 G=9,1,1,1

RESTRAINTS
1 R=0,0,1,1,1,0
2 10 1 R=0,0,1,1,1,0
11 R=1,1,1,1,1,1

LOADS
1 L=1 F=236.7,-5.92,0,0,0,-118.4

SAP90 OUTPUT FILE - NO P • Δ EFFECTS

PROGRAM: SAP90/FILE: NPD4 . SOL

NPD4 - INVERT SLAB - 14 FOOT UNSUPPORTED LENGTH - NO P-DELTA EFFECTS

J O I N T D I S P L A C E M E N T S

LOAD CONDITION 1 - DISPLACEMENTS "U" AND ROTATIONS "R"

JOINT	U(X)	U(Y)	R(Z)
1	0.003465	0.014526	-0.002949
2	0.003118	0.010781	-0.002448
3	0.002772	0.007712	-0.001986
4	0.002425	0.005263	-0.001565
5	0.002079	0.003375	-0.001188
6	0.001732	0.001984	-0.000858
7	0.001386	0.001022	-0.000578
8	0.001039	0.000419	-0.000349
9	0.6930E-03	0.1004E-03	-0.1747E-03
10	0.3465E-03	-0.1208E-04	-0.5755E-04
11	0.000000	0.000000	0.000000

R E A C T I O N S A N D A P P L I E D F O R C E S

LOAD CONDITION 1 - FORCES "F" AND MOMENTS "M"

JOINT	F(X)	F(Y)	M(Z)
1	236.7000	-5.9200	-118.4000
2	0.0000	0.0000	0.0000
3	0.0000	0.0000	0.0000
4	0.0000	0.0000	0.0000
5	0.0000	0.0000	0.0000
6	0.0000	0.0000	0.0000
7	0.0000	0.0000	0.0000
8	0.0000	0.0000	0.0000
9	0.0000	0.0000	0.0000
10	0.0000	0.0000	0.0000
11	-236.7000	10.1200	6.1200
TOTAL	0.0000E+00	0.4200E+01	-0.1123E+03

FRAME ELEMENT FORCES

ELT ID	LOAD COND	DIST ENDI	1-2 PLANE		AXIAL FORCE
			SHEAR	MOMENT	
1	1	0.000			-236.700
		0.000	-5.920	118.400	
		1.400	-6.340	109.818	
		1.400			-236.700
2	1	0.000			-236.700
		0.000	-6.340	109.818	
		1.400	-6.760	100.648	
		1.400			-236.700
3	1	0.000			-236.700
		0.000	-6.760	100.648	
		1.400	-7.180	90.890	
		1.400			-236.700
4	1	0.000			-236.700
		0.000	-7.180	90.890	
		1.400	-7.600	80.544	
		1.400			-236.700
5	1	0.000			-236.700
		0.000	-7.600	80.544	
		1.400	-8.020	69.610	
		1.400			-236.700
6	1	0.000			-236.700
		0.000	-8.020	69.610	
		1.400	-8.440	58.088	
		1.400			-236.700
7	1	0.000			-236.700
		0.000	-8.440	58.088	
		1.400	-8.860	45.978	
		1.400			-236.700
8	1	0.000			-236.700
		0.000	-8.860	45.978	
		1.400	-9.280	33.280	
		1.400			-236.700
9	1	0.000			-236.700
		0.000	-9.280	33.280	
		1.400	-9.700	19.994	
		1.400			-236.700
10	1	0.000			-236.700
		0.000	-9.700	19.994	
		1.400	-10.120	6.120	
		1.400			-236.700

SAP90 INPUT FILE - P • Δ EFFECTS INCLUDED

YPD3 - INVERT SLAB - 14 FOOT UNSUPPORTED LENGTH - P-DELTA EFFECTS
C ECCENTRICITY AT 0.25T
C AXIAL LOAD AT 236.7 KIPS
C EFFECTIVE CANTILEVER LENGTH = 14 FEET
C COMPRESSION STRUT SHEAR COMPONENT = 5.92 KIPS
C UNITS ARE KIPS FEET

SYSTEM
L=1

JOINTS
1 X=0 Y=0 Z=0
11 X=14 Y=0 Z=0 G=1,11,1

FRAME
NM=1 NL=1
1 SH=R T=2,1 E=478200
1 WG=0,-0.30
1 1 2 M=1 LP=1,0 NSL=1 G=9,1,1,1

RESTRAINTS
1 R=0,0,1,1,1,0
2 10 1 R=0,0,1,1,1,0
11 R=1,1,1,1,1,1

LOADS
1 L=1 F=236.7,-5.92,0,0,0,-118.4

PDELTA
M=10 TOLD=0.005
L=1 SF=1

SAP90 OUTPUT FILE - P • Δ EFFECTS INCLUDED

PROGRAM: SAP90/FILE: YPD3.SOL

YPD3 - INVERT SLAB - 14 FOOT UNSUPPORTED LENGTH - P-DELTA EFFECTS

JOINT DISPLACEMENTS

LOAD CONDITION 1 - DISPLACEMENTS "U" AND ROTATIONS "R"

JOINT	U(X)	U(Y)	R(Z)
1	0.003465	0.015545	-0.003068
2	0.003118	0.011631	-0.002565
3	0.002772	0.008400	-0.002097
4	0.002425	0.005800	-0.001667
5	0.002079	0.003775	-0.001279
6	0.001732	0.002264	-0.000936
7	0.001386	0.001203	-0.000641
8	0.001039	0.000521	-0.000397
9	0.6930E-03	0.1457E-03	-0.2070E-03
10	0.3465E-03	-0.7636E-06	-0.7372E-04
11	0.000000	0.000000	0.000000

REACTIONS AND APPLIED FORCES

LOAD CONDITION 1 - FORCES "F" AND MOMENTS "M"

JOINT	F(X)	F(Y)	M(Z)
1	236.7000	-5.9200	-118.4000
2	0.0000	0.0000	0.0000
3	0.0000	0.0000	0.0000
4	0.0000	0.0000	0.0000
5	0.0000	0.0000	0.0000
6	0.0000	0.0000	0.0000
7	0.0000	0.0000	0.0000
8	0.0000	0.0000	0.0000
9	0.0000	0.0000	0.0000
10	0.0000	0.0000	0.0000
11	-236.7000	10.1200	9.7995
TOTAL	0.0000E+00	0.4200E+01	-0.1086E+03

F R A M E E L E M E N T F O R C E S

ELT ID	LOAD COND	DIST ENDI	1-2 PLANE		AXIAL FORCE
			SHEAR	MOMENT	
1 -----					
			ACTING P-DELTA AXIAL FORCE:		-236.700
1	0.000				-236.700
	0.000		-5.920	118.400	
	1.400		-6.340	110.744	
	1.400				-236.700
2 -----					
			ACTING P-DELTA AXIAL FORCE:		-236.700
1	0.000				-236.700
	0.000		-6.340	110.744	
	1.400		-6.760	102.339	
	1.400				-236.700
3 -----					
			ACTING P-DELTA AXIAL FORCE:		-236.700
1	0.000				-236.700
	0.000		-6.760	102.339	
	1.400		-7.180	93.197	
	1.400				-236.700
4 -----					
			ACTING P-DELTA AXIAL FORCE:		-236.700
1	0.000				-236.700
	0.000		-7.180	93.197	
	1.400		-7.600	83.330	
	1.400				-236.700
5 -----					
			ACTING P-DELTA AXIAL FORCE:		-236.700
1	0.000				-236.700
	0.000		-7.600	83.330	
	1.400		-8.020	72.754	
	1.400				-236.700
6 -----					
			ACTING P-DELTA AXIAL FORCE:		-236.700
1	0.000				-236.700
	0.000		-8.020	72.754	
	1.400		-8.440	61.483	
	1.400				-236.700
7 -----					
			ACTING P-DELTA AXIAL FORCE:		-236.700
1	0.000				-236.700
	0.000		-8.440	61.483	
	1.400		-8.860	49.534	
	1.400				-236.700

8	-----			
	ACTING P-DELTA AXIAL FORCE:			-236.700
	1	0.000		-236.700
		0.000	-8.860	49.534
		1.400	-9.280	36.925
		1.400		-236.700
9	-----			
	ACTING P-DELTA AXIAL FORCE:			-236.700
	1	0.000		-236.700
		0.000	-9.280	36.925
		1.400	-9.700	23.674
		1.400		-236.700
10	-----			
	ACTING P-DELTA AXIAL FORCE:			-236.700
	1	0.000		-236.700
		0.000	-9.700	23.674
		1.400	-10.120	9.799
		1.400		-236.700

8 Summary, Conclusions, and Recommendations

8.1 Summary and Conclusions

Investigations based on minimum recommended sections for invert slabs constructed on rock and earth and for both continuous reinforcing plans and independent block plans indicate the limit-state axial load capacity of the slab can be estimated based on short column interaction. Based on the assumptions contained in the simple method used in this report to estimate the limit-state axial load capacity of spillway invert slabs:

- a. A 1-ft-thick invert slab on rock has a limit-state axial load capacity of 118.4 kips per foot width of slab. The point of application of the axial load is midway between the slab neutral axis and the top surface (i.e., positive eccentricity equal to $0.25 T$).
- b. A 2-ft-thick invert slab on earth has a limit-state axial load capacity of 236.7 kips per foot width of slab. Also, the point of application of the axial load is midway between the slab neutral axis and the top surface (i.e., positive eccentricity equal to $0.25 T$).

The limit-state axial load capacity of invert slab sections other than those of minimum thickness can be estimated using the analytical procedures described previously.

It should be noted that the simplifying assumptions used in the analyses of rock-founded invert slabs did not consider the benefits of rock anchors that are usually provided to resist uplift. This means the procedure is applicable to invert slab on rock foundations with or without rock anchor tie-downs. It should also be noted that invert slab moments due to axial load eccentricity reduce to zero a short distance (20 ft or less) from the spillway wall footing-invert slab interface. This means the axial load for usual contraction joint arrangements will be concentric before reaching the first contraction joint location. Thus invert slab behavior for 20-, 25-, and 30-ft spacings will be similar. This is also true for channels of various widths (other than the 60-ft width used in analyses in this report).

As mentioned in Section 1.2, the behavior of systems involving structure-soil-foundation interaction, especially when subjected to time-varying earthquake ground motions, is complex. The procedures used herein to develop the limit-state axial load capacities of invert slabs are based on many simplifying assumptions, which to date have not been supported by experimental testing or comprehensive analytical studies. Therefore, engineers are cautioned to assess and review applicability of the assumptions made in this report carefully to assure that these assumptions are applicable to their particular situation prior to their application on their Corps project. Additionally, the simplified analysis of invert slabs on earth foundations presumes there is an adequate factor of safety against liquefaction, and against seismically induced pore-water pressures that might develop in the earth foundation supporting the invert slab. This is a performance requirement for all design earthquakes selected for project design or evaluation. Per Corps of Engineers requirements (Headquarters, U.S. Army Corps of Engineers 1995a), design earthquakes would include the operational basis earthquake (OBE) and the maximum design earthquake (MDE). The authors of this report assume that performance evaluations for liquefaction and seismically induced pore-water pressures are made for the project by the design engineer.

In the design of buildings it is sometimes acceptable to use the axial loads and moments from a conventional structural analysis in combination with a simple moment magnifier approach to approximate slender column secondary moment ($P \bullet \Delta$) effects. The moment magnifier factor for the design of columns (ACI 318 (ACI 2002)) is a function of the ratio of the column load to the critical buckling load. The critical buckling load represents the applied compressive end force(s) determined by Euler equation to cause an ideal column (slender weightless column with round pin-connected ends) when bent in single curvature and restrained against lateral movement at the loaded ends (i.e., side sway prevented) to reach a condition of elastic instability. The critical buckling load for the ideal column is modified in ACI 318 to approximate secondary moment effects for deflected shapes other than those occurring under ideal conditions (i.e., different end conditions and/or side sway). This is accomplished by using a prescribed "effective" column length rather than the "actual" column length. This type of approximation is strongly discouraged by MacGregor, Breen, and Pfrang (1970) for special column conditions such as those that might occur in unbraced or partially braced frames. Instead, MacGregor, Breen, and Pfrang (1970) recommend using a rational second-order structural analysis to estimate $P \bullet \Delta$ effects. Invert slab systems have a unique deflected shape, one that is influenced by slab dead load effects and foundation resistance (i.e., resistance that develops as the slab deflects downward into the foundation). Therefore, a moment magnifier approach should be discouraged according to the logic posed by MacGregor, Breen, and Pfrang (1970). Additional factors not common to typical columns and affecting the behavior of invert slabs are discussed in Section 3.1. As demonstrated in this report, a beam on elastic foundation analysis can be used, in conjunction with several simplifying assumptions, to approximate the deflected shape of invert slabs, and moment magnification effects can be estimated by rational second-order analysis (i.e., $P \bullet \Delta$ analysis).

8.2 Research and Development Needs

The next step in research will be to perform comprehensive analytical studies using sophisticated, finite-element-based, earthquake time-history analysis tool(s) for the seismic response of Corps T-walls buttressed by invert spillway slabs. Computed results would be compared with those from the simplified methods used to estimate the limit-state axial load capacity of spillway invert slabs described herein. The research should be directed toward validating the use of the simple design procedures described herein and used in conjunction with CWRotate-“Dry.”

References

- American Concrete Institute. (2002). "Building code requirements for structural concrete (ACI 318-02) and commentary (ACI 318-R-02)," American Concrete Institute, Farmington Hills, MI.
- American Society for Testing and Materials. (2003). "Standard specification for deformed and plain billet-steel bars for concrete reinforcement," ASTM A615/A615M-03a, West Conshohocken, PA.
- Dawkins, W. P. (1994). "User's guide: Computer program for analysis of beam-column structures with nonlinear supports (CBEAMC)," Instruction Report ITL-94-6, U.S. Army Engineer Waterways Experiment Station, Vicksburg, MS.
- Ebeling, R. M., and Morrison, E. E. (1992). "The seismic design of waterfront retaining structures," Technical Report ITL-92-11, U.S. Army Engineer Waterways Experiment Station, Vicksburg, MS.
- Ebeling, R. M., and Pace, M. E. (1996). "Uplift pressures resulting from flow along tapered rock joints," *REMR Bulletin*, U.S. Army Engineer Waterways Experiment Station, Vicksburg, MS, 13 (1).
- Ebeling, R. M., and White, B. C. "The rotational or sliding response to earthquake ground motions of toe-restrained walls retaining moist backfills," in preparation, U.S. Army Engineer Research and Development Center, Vicksburg, MS.
- Ebeling, R. M., Pace, M. E., and Morrison, E. E. (1997). "Evaluating the stability of existing massive concrete gravity structures founded on rock," Technical Report REMR-CS-54, U.S. Army Engineer Waterways Experiment Station, Vicksburg, MS.
- Federal Emergency Management Agency. (2000). "Prestandard and commentary for the seismic rehabilitation of buildings," FEMA 356, Washington, DC.
- Harza, L. F. (1951). "Analysis of design-Fort Randall Reservoir Spillway-Stage II," with letter report entitled "Supplementary report on monolith slab," Report to U.S. Army Engineer District, Omaha, October 1951, L. F. Harza Engineering Company, Chicago, IL.

- Headquarters, U.S. Army Corps of Engineers. (1994). "Rock foundations," EM 1110-1-2908, Washington, DC.
- Headquarters, U.S. Army Corps of Engineers. (1995a). "Earthquake design and evaluation for civil works projects," ER 1110-2-1806, Washington, DC.
- Headquarters, U.S. Army Corps of Engineers. (1995b). "Seismic design provisions for roller compacted concrete dams; Appendix E, Tensile strength of roller compacted concrete," EP 1110-2-12, Washington, DC.
- Liu, T. G., and McDonald, J. E. (1978). "Prediction of tensile strain capacity of mass concrete," *ACI Journal*, 192-197.
- MacGregor, J. G., Breen, J. E., and Pfrang, E. O. (1970). "Design of slender concrete columns," *ACI Journal*, 6-28.
- Mathsoft, Inc. (1998). "Mathcad 8," Cambridge, MA.
- Murphy, W. L., Ebeling, R. M., and Andersen, J. M. (2002). "Assessment of geology as it pertains to modeling uplift in jointed rock: A basis for inclusion of uncertainty in flow models," Technical Report ERDC TR-02-2, U.S. Army Engineer Research and Development Center, Vicksburg, MS.
- Priestley, M. J. N., Verma, R., and Xiao, Y. (1984). "Seismic shear strength of reinforced concrete columns," *ASCE Journal of Structural Engineering* 120(8), 2310-2329.
- Raphael, J. M. (1984). "Tensile strength of concrete," Technical Paper No. 81-17, *ACI Journal*, 158-165.
- Sabatini, P. J., Pass, D. G., and Bachus, R. C. (1999). "Geotechnical Engineering Circular No. 4, Ground anchors and anchored systems," Report No. FHWA-IF-99-015, Federal Highway Administration, Washington, DC.
- Stone and Webster Engineering corporation. (1992). "Uplift pressures, shear strengths, and tensile strengths for stability analysis of concrete gravity dams," Report TR-100345, Volume 1, Project 2917-05, Final Report, Denver, CO, prepared for Electric Power Research Institute, Palo Alto, CA.
- Wilson, E. L., and Habibullah, A. (1990). "SAP90 – A series of computer programs for the finite element analysis of structures," Computers and Structures, Inc., Berkley, CA.

REPORT DOCUMENTATION PAGE

Form Approved
OMB No. 0704-0188

Public reporting burden for this collection of information is estimated to average 1 hour per response, including the time for reviewing instructions, searching existing data sources, gathering and maintaining the data needed, and completing and reviewing this collection of information. Send comments regarding this burden estimate or any other aspect of this collection of information, including suggestions for reducing this burden to Department of Defense, Washington Headquarters Services, Directorate for Information Operations and Reports (0704-0188), 1215 Jefferson Davis Highway, Suite 1204, Arlington, VA 22202-4302. Respondents should be aware that notwithstanding any other provision of law, no person shall be subject to any penalty for failing to comply with a collection of information if it does not display a currently valid OMB control number. PLEASE DO NOT RETURN YOUR FORM TO THE ABOVE ADDRESS.

1. REPORT DATE (DD-MM-YYYY) August 2004		2. REPORT TYPE Final report		3. DATES COVERED (From - To)					
4. TITLE AND SUBTITLE Simple Methods Used to Estimate the Limit-State Axial Load Capacity of Spillway Invert Slabs				5a. CONTRACT NUMBER					
				5b. GRANT NUMBER					
				5c. PROGRAM ELEMENT NUMBER					
6. AUTHOR(S) Ralph W. Strom, Robert M. Ebeling				5d. PROJECT NUMBER					
				5e. TASK NUMBER					
				5f. WORK UNIT NUMBER 33215a					
7. PERFORMING ORGANIZATION NAME(S) AND ADDRESS(ES) 9474 S.E. Carnaby Way, Portland, OR 97266; U.S. Army Engineer Research and Development Center, Information Technology Laboratory, 3909 Halls Ferry Road, Vicksburg, MS 39180-6199				8. PERFORMING ORGANIZATION REPORT NUMBER ERDC/ITL TR-04-3					
9. SPONSORING / MONITORING AGENCY NAME(S) AND ADDRESS(ES) U.S. Army Corps of Engineers Washington, DC 20314-1000				10. SPONSOR/MONITOR'S ACRONYM(S)					
				11. SPONSOR/MONITOR'S REPORT NUMBER(S)					
12. DISTRIBUTION / AVAILABILITY STATEMENT Approved for public release; distribution is unlimited									
13. SUPPLEMENTARY NOTES									
14. ABSTRACT <p>Invert spillway slabs provide an important contribution to the overall seismic stability of retaining walls, especially those earth-retaining L-walls and T-walls (sometimes referred to as cantilever retaining walls) that border spillway channels. Key to the seismic performance of spillway retaining walls is the stabilizing force that the channel invert slab exerts at the toe of the wall. The magnitude of this stabilizing force will depend on the limit state axial load capacity of the invert slab.</p> <p>Invert slabs can be founded on earth or rock. Types of construction used by the Corps include an independent block plan and a continuous reinforcing plan. Invert slabs when loaded axially can exhibit either short column or long column behavior with the latter term referring to slabs whose axial capacity is reduced by second-order deformations (i.e., $P \bullet \Delta$ effects).</p> <p>Slab capacity in terms of axial load-moment interaction is determined based on ultimate strength design principles and applied to both unreinforced (plain concrete) and reinforced concrete sections. Influences from the subgrade reaction, slab dead load, and axial load eccentricity are considered in the analyses to develop an understanding of invert slab behavior and the influence, if any, second-order deformations may have in reducing the axial load capacity.</p>									
15. SUBJECT TERMS <table style="width: 100%; border: none;"> <tr> <td style="width: 50%;">Limit-state axial load capacity</td> <td style="width: 50%;">Seismic stabilizing force contribution</td> </tr> <tr> <td>Second-order deformation effects</td> <td>Spillway invert slabs</td> </tr> </table>						Limit-state axial load capacity	Seismic stabilizing force contribution	Second-order deformation effects	Spillway invert slabs
Limit-state axial load capacity	Seismic stabilizing force contribution								
Second-order deformation effects	Spillway invert slabs								
16. SECURITY CLASSIFICATION OF:			17. LIMITATION OF ABSTRACT	18. NUMBER OF PAGES	19a. NAME OF RESPONSIBLE PERSON				
a. REPORT UNCLASSIFIED	b. ABSTRACT UNCLASSIFIED	c. THIS PAGE UNCLASSIFIED			70	19b. TELEPHONE NUMBER (include area code)			