

OCT 11 2004

REPORT DOCUMENTATION PAGE

Form Approved  
OMB No. 0704-0188

The public reporting burden for this collection of information is estimated to average 1 hour per response, including the time for reviewing instructions, searching existing data sources, gathering and maintaining the data needed, and completing and reviewing the collection of information. Send comments regarding this burden estimate or any other aspect of this collection of information, including suggestions for reducing the burden, to Department of Defense, Washington Headquarters Services, Directorate for Information Operations and Reports (0704-0188), 1215 Jefferson Davis Highway, Suite 1204, Arlington, VA 22202-4302. Respondents should be aware that notwithstanding any other provision of law, no person shall be subject to any penalty for failing to comply with a collection of information if it does not display a currently valid OMB control number.

PLEASE DO NOT RETURN YOUR FORM TO THE ABOVE ADDRESS.

1. REPORT DATE (DD-MM-YYYY) 05-01-2004		2. REPORT TYPE Final		3. DATES COVERED (From - To) 05-01-2003 - 05-01-2004	
4. TITLE AND SUBTITLE Scale-Time offset Robust Modulation (STORM) Foundational Analysis Final Report				5a. CONTRACT NUMBER	
				5b. GRANT NUMBER N00014-03-0130	
				5c. PROGRAM ELEMENT NUMBER	
6. AUTHOR(S) Dr. Randy K Young Peters, Wyckoff				5d. PROJECT NUMBER 09504	
				5e. TASK NUMBER 01	
				5f. WORK UNIT NUMBER	
7. PERFORMING ORGANIZATION NAME(S) AND ADDRESS(ES) Applied Research Laboratory The Pennsylvania State University P.O. Box 30 State College, PA 16804				8. PERFORMING ORGANIZATION REPORT NUMBER	
9. SPONSORING/MONITORING AGENCY NAME(S) AND ADDRESS(ES) ONR 313 Philemon Johnson 800 North Quincy Street Arlington, VA 22217-5660				10. SPONSOR/MONITOR'S ACRONYM(S) ONR 313	
				11. SPONSOR/MONITOR'S REPORT NUMBER(S)	
12. DISTRIBUTION/AVAILABILITY STATEMENT Unlimited					
13. SUPPLEMENTARY NOTES 20041021 144					
14. ABSTRACT The STORM Foundational Analysis Final Report documents the research performed quantifying the performance of the STORM modulation.					
15. SUBJECT TERMS STORM, Modulation, Robust					
16. SECURITY CLASSIFICATION OF:			17. LIMITATION OF ABSTRACT UU	18. NUMBER OF PAGES 23	19a. NAME OF RESPONSIBLE PERSON Dr Randy K Young
a. REPORT Unclass	b. ABSTRACT Unclass	c. THIS PAGE Unclass			19b. TELEPHONE NUMBER (include area code) 814-865-1493

## INSTRUCTIONS FOR COMPLETING SF 298

- 1. REPORT DATE.** Full publication date, including day, month, if available. Must cite at least the year and be Year 2000 compliant, e.g. 30-06-1998; xx-06-1998; xx-xx-1998.
- 2. REPORT TYPE.** State the type of report, such as final, technical, interim, memorandum, master's thesis, progress, quarterly, research, special, group study, etc.
- 3. DATES COVERED.** Indicate the time during which the work was performed and the report was written, e.g., Jun 1997 - Jun 1998; 1-10 Jun 1996; May - Nov 1998; Nov 1998.
- 4. TITLE.** Enter title and subtitle with volume number and part number, if applicable. On classified documents, enter the title classification in parentheses.
  - 5a. CONTRACT NUMBER.** Enter all contract numbers as they appear in the report, e.g. F33615-86-C-5169.
  - 5b. GRANT NUMBER.** Enter all grant numbers as they appear in the report, e.g. AFOSR-82-1234.
  - 5c. PROGRAM ELEMENT NUMBER.** Enter all program element numbers as they appear in the report, e.g. 61101A.
  - 5d. PROJECT NUMBER.** Enter all project numbers as they appear in the report, e.g. 1F665702D1257; ILIR.
  - 5e. TASK NUMBER.** Enter all task numbers as they appear in the report, e.g. 05; RF0330201; T4112.
  - 5f. WORK UNIT NUMBER.** Enter all work unit numbers as they appear in the report, e.g. 001; AFAPL30480105.
- 6. AUTHOR(S).** Enter name(s) of person(s) responsible for writing the report, performing the research, or credited with the content of the report. The form of entry is the last name, first name, middle initial, and additional qualifiers separated by commas, e.g. Smith, Richard, J, Jr.
- 7. PERFORMING ORGANIZATION NAME(S) AND ADDRESS(ES).** Self-explanatory.
- 8. PERFORMING ORGANIZATION REPORT NUMBER.** Enter all unique alphanumeric report numbers assigned by the performing organization, e.g. BRL-1234; AFWL-TR-85-4017-Vol-21-PT-2.
- 9. SPONSORING/MONITORING AGENCY NAME(S) AND ADDRESS(ES).** Enter the name and address of the organization(s) financially responsible for and monitoring the work.
- 10. SPONSOR/MONITOR'S ACRONYM(S).** Enter, if available, e.g. BRL, ARDEC, NADC.
- 11. SPONSOR/MONITOR'S REPORT NUMBER(S).** Enter report number as assigned by the sponsoring/monitoring agency, if available, e.g. BRL-TR-829; -215.
- 12. DISTRIBUTION/AVAILABILITY STATEMENT.** Use agency-mandated availability statements to indicate the public availability or distribution limitations of the report. If additional limitations/ restrictions or special markings are indicated, follow agency authorization procedures, e.g. RD/FRD, PROPIN, ITAR, etc. Include copyright information.
- 13. SUPPLEMENTARY NOTES.** Enter information not included elsewhere such as: prepared in cooperation with; translation of; report supersedes; old edition number, etc.
- 14. ABSTRACT.** A brief (approximately 200 words) factual summary of the most significant information.
- 15. SUBJECT TERMS.** Key words or phrases identifying major concepts in the report.
- 16. SECURITY CLASSIFICATION.** Enter security classification in accordance with security classification regulations, e.g. U, C, S, etc. If this form contains classified information, stamp classification level on the top and bottom of this page.
- 17. LIMITATION OF ABSTRACT.** This block must be completed to assign a distribution limitation to the abstract. Enter UU (Unclassified Unlimited) or SAR (Same as Report). An entry in this block is necessary if the abstract is to be limited.

PENNSTATE



Applied Research Laboratory

## Scale-Time Offset Robust Modulation (STORM) Foundational Analysis Final Report

Peter S. Wyckoff, Randy K. Young  
*Applied Research Laboratory  
The Pennsylvania State University*

### Sponsor

*Dr. Dennis McGregor  
ONR 313*

*Office of Naval Research Grant No. N00014-03-1-0130*

### **Abstract**

Scale Time Offset Robust Modulation (STORM) is a unique modulation technique that enables highly flexible multi-resolution processing of signals through time variant multi-path channels. STORM may be used as a stand-alone modulation technique or it can be used in conjunction with more conventional systems that require rapid and robust synchronization. STORM combines time scaling and transmitted reference spread spectrum modulation. This innovation enables variable time resolution, variable processing rates, and controllable non-coherent multi-path gain.

Potential STORM applications are HF ALE systems, wireless MANET's, spread spectrum communication, and navigation systems. STORM is well suited to applications which emphasize simple acquisition over excellent noise performance.

This STORM foundational analysis examined the robustness, performance, processing efficiency, and potential applications. Robust performance is examined for fading channels in space and time. Performance analysis begins with the AWGN channel benchmark and then compares STORM and matched filtering over frequency selective channels. Next STORM processing efficiency is detailed and synchronization applications are explored. The appendix to this final report contains three FY03 IEEE STORM publications.

This foundational analysis concludes that STORM is a unique supplement to existing and future communications systems that offers the potential for better overall communications systems performance at a low cost. Each specific communications system may employ STORM for different features; however, STORM's ability to enable "dial-up" trade-offs between link throughput and link security offers immediate transition paths to some existing and about-to-exist communications systems.

TABLE OF CONTENTS

<b>INTRODUCTION</b> .....	<b>1</b>
<b>MODULATION DESCRIPTION</b> .....	<b>2</b>
TIME OFFSET MODULATION BACKGROUND.....	2
STORM TRANSMIT SIGNAL DESIGN .....	4
STORM DEMODULATION .....	5
<b>PERFORMANCE</b> .....	<b>5</b>
ROBUST DETECTION .....	6
SYNCHRONIZATION .....	8
<i>Perfect Synchronization</i> .....	8
<i>Asynchronous Reception</i> .....	9
PROCESSING RATE .....	11
MULTI-PATH RECEPTION.....	12
<i>Matched Filter Receiver</i> .....	14
<i>Storm Demodulator</i> .....	15
<i>Comparing STORM and Matched Filtering Output SNR</i> .....	15
<i>Multi-path Summary</i> .....	16
<b>APPLICATIONS</b> .....	<b>16</b>
STORM ASSISTED COMMUNICATION ACQUISITION .....	16
<b>CONCLUSION</b> .....	<b>19</b>
<b>REFERENCES</b> .....	<b>19</b>

TABLE OF FIGURES

FIGURE 1 TIME OFFSET MODULATION .....	3
FIGURE 2 STORM MODULATOR.....	4
FIGURE 3 STORM MODULATION.....	4
FIGURE 4 STORM CORRELATION RECEIVER.....	5
FIGURE 5 BER PERFORMANCE FOR SPREADING RATIOS 1024, 2048, AND 32768 .....	6
FIGURE 6 OFFSET SIGNALS PROVIDE ROBUST DETECTION.....	7
FIGURE 7 VISUALIZING HIGHLY OVERLAPPED STORM SIGNALS.....	8
FIGURE 8 SYNCHRONOUS RECEPTION .....	9
FIGURE 9 UNSYNCHRONIZED DEMODULATION .....	10
FIGURE 10 COMPARISON OF TIME RESOLUTION AND PROCESSING RATES .....	11
FIGURE 11 FLEXIBLE MULTI-PATH ENERGY STACKING .....	12
FIGURE 12 MULTI-PATH RECEPTION .....	13
FIGURE 13 STORM ASSISTED DS-CDMA ACQUISITION.....	17
FIGURE 14 SIMULTANEOUS DETECTIONS WITH PERFECT SYNCHRONIZATION .....	18
FIGURE 15 STORM DETECTION WITH 100 CHIP MISALIGNMENT .....	18

## ABSTRACT

Scale Time Offset Robust Modulation is a unique modulation technique that enables highly flexible multi-resolution processing of signals through time variant multi-path channels. STORM may be used as a stand-alone modulation technique or it can be used in conjunction with more conventional systems that require rapid and robust synchronization. STORM combines time scaling and transmitted reference spread spectrum modulation. This innovation enables variable time resolution, variable processing rates, and controllable non-coherent multi-path gain.

Potential STORM applications are HF ALE systems, wireless MANET's, spread spectrum communication, and navigation systems. STORM is well suited to applications which emphasize simple acquisition over excellent noise performance.

This foundational analysis examined the robustness, performance, processing efficiency, and potential applications. Robust performance is examined for fading channels in space and time. Performance analysis begins with the AWGN channel benchmark and then compares STORM and matched filtering over frequency selective channels. Next STORM processing efficiency is detailed and synchronization applications are explored. The appendix contains three FY03 IEEE STORM publications.

This foundational analysis concludes that STORM is a unique supplement to existing and future communications systems that offers the potential for better overall communications systems performance at a low cost. Each specific communications system may employ STORM for different features; however, STORM's ability to enable "dial-up" trade-offs between link throughput and link security offers immediate transition paths to some existing and about-to-exist communications systems.

## INTRODUCTION

Scale time offset robust modulation is a novel modulation technique that essentially adds time scaling to transmitted reference modulation techniques [1-4,6]. Transmitted reference, TR, modulation enables spreading with a truly random sequence that is not predictable and reception with instant synchronization.

Prior systems have used TR signal pairs which are offset in frequency [2] or time [3,4,6] but not time scale. More complex systems have used a mechanism such as stored reference spreading to secure the reference transmission [1]. TR systems which offset the signals in frequency can be difficult to match and require additional bandwidth. Furthermore, multi-path propagation de-correlates two different channels when the frequency offset exceeds the channel coherence bandwidth or the time offset exceeds the channel coherence time. De-correlating the received reference and offset waveforms reduces the available detection energy which ultimately increases the BER. Signals which use time offset alone often appear identical to multi-path signals.

The STORM transmit signal is also created using a pair of relatively offset signals. These signals are called the base and offset signals. The base signal may be random noise, colored noise, a PN sequence, or QAM. The offset signal is created from a copy of the base signal that is offset in time, time scale, phase, and/or amplitude depending on the current data symbol. Setting the time scale close to one produces similar base and offset signals; thus, each signal is distorted similarly

by transmission and channel degradations when these are highly overlapped in time and frequency. Summing the offset and base signal produces the transmitted waveform.

In practice, relative motion does not time scale wideband electromagnetic signals significantly since the speed of light is  $3 \times 10^8$  m/s. Extreme relative motion at 3 km/s time scales signals by only  $1 + 10^{-5}$ . Since significant time scaling does not naturally occur, this modulation is distinct from multi-path. While the received waveform may be de-correlated with the transmit waveform, the received base and offset signals may remain relatively correlated. Therefore robust rapid detection is possible despite an unknown channel, receiver frequency offset, and arrival time.

The simplest complete STORM system consists of a modulator and demodulator. The modulator and demodulator appear similar to time offset and DCSK systems with the addition of time scaling. STORM demodulation may also be explained as an extension of time offset demodulation.

The STORM signal design offers a number of attractive features. First, the signal may be robustly detected even when the transmit and receive signals are de-correlated provided the base and offset signals are distorted similarly. Second, while using a fixed bandwidth the multi-path resolution may be varied by changing the scale parameter. Thus the demodulator can automatically perform non-coherent stacking of multi-path energy for communications applications without using the rake architecture, or it may independently resolve multi-path components for localization and radar applications. Finally, processing rates are typically orders of magnitude lower than a comparable bandwidth matched filter receiver when the scale parameter is known in advance.

## **Modulation Description**

STORM is similar to time offset modulation. Time offset modulation is a transmitted reference spread spectrum technique that has been used to some degree in RF and fiber optic applications. This material is briefly reviewed. Then the modulation and demodulation processes for STORM are explained.

### ***TIME OFFSET MODULATION BACKGROUND***

When the STORM time scale parameter is equal to one the signal becomes similar to time offset modulation which is a familiar transmitted reference spread spectrum modulation. Time offset modulation creates a base signal and a modulated version of the base signal [3,4,6].

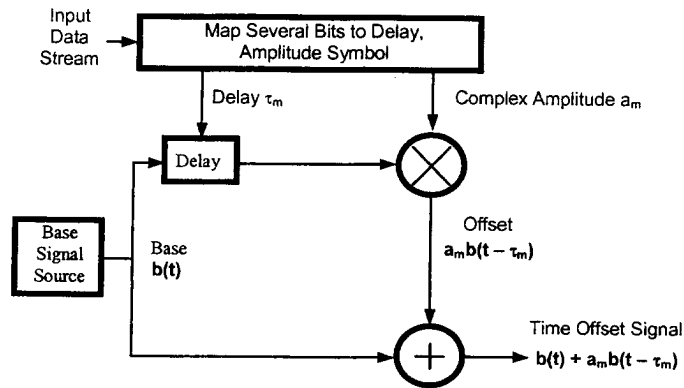

**Figure 1** Time Offset Modulation

The base signal may be wideband short duration, narrow band long duration, or wideband long duration. Examples include noise, PN sequences, BPSK, FSK, QAM, and chaotic signals. Narrow band short duration signals typically have ambiguous correlation features.

Time offset modulation information is conveyed by the relative time offset and complex amplitude offset between the reference and modulated versions of the base signal source. Figure 1 contains a modulator schematic. First a base signal is created. Next the base signal is delayed in time. Finally the delayed signal is multiplied by the complex amplitude offset and the result is summed with the original base signal. The delay and amplitude offset may be a function of the data symbol to be transmitted. The transmit signal is,

$$x(t) = b(t) + a_m b(t - \tau_m)$$

when the base signal is  $b(t)$  and the amplitude offset is  $a_m$  while the applied delay is  $\tau_m$ .

Time offset demodulators estimate the received signal auto-correlation at one or more specified lags. This approach has recently been applied to FM-DCSK [4] where the received signal is multiplied by a time delayed version of itself. Integrating the product signal yields an estimate of the receive signal auto-correlation at the chosen delay. A common operator which estimates the autocorrelation over the symbol period  $T$  is:

$$\hat{\phi}_{xx}(t_o, \tau) = \frac{1}{T} \int_{t_o}^{t_o+T} x(t)x^*(t-\tau)dt$$

If the demodulator delay matches the modulator delay, the reference and offset signal will show a high degree of correlation when present. A recent publication details this approach using real amplitude offsets from  $\{-1, +1\}$  [4] while another paper detailed complex amplitude offsets [3] and another applies time hopping delays [6]. When more than one delay is used, multiple time offset correlations are required. The largest correlation magnitude typically determines the transmitted symbol.

## STORM TRANSMIT SIGNAL DESIGN

STORM extends transmitted reference modulation using time scaling. STORM modulation data is conveyed in the relative time offset, time scale offset, and complex amplitude offset between the base and the offset signals.

As shown in Figure 2, an input data stream creates the information symbol in delay, time scale, and amplitude. Delay simply shifts the signal in time. Time scaling dilates or compresses the signal in time. Multiplication by the complex amplitude offset determines the phase and amplitude difference between the base and offset signals.

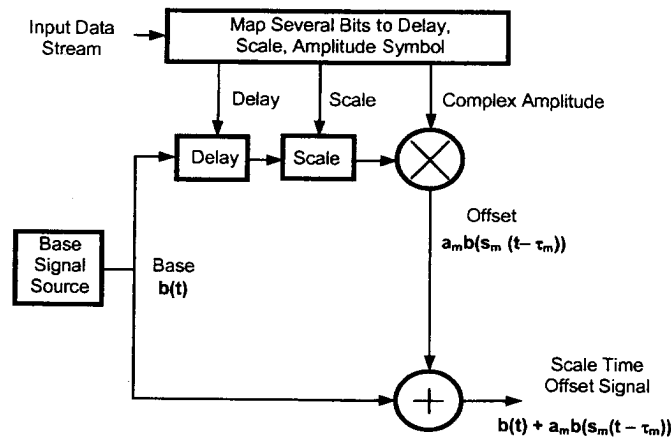

Figure 2 STORM Modulator

Figure 3 illustrates four steps used to create the STORM signal. First the base signal is delayed by  $\tau_m$ . Then the delayed base signal is time scaled by  $s_m$ . Finally the time-scaled offset signal is multiplied by the complex amplitude offset,  $a_m$ , and this result is added to the original base signal. The STORM signal is,

$$x(t) = b(t) + a_m b(s_m(t - \tau_m))$$

using the base signal  $b(t)$  with applied amplitude, time scale, and delay offsets  $a_m$ ,  $s_m$ , and  $t_m$  respectively.

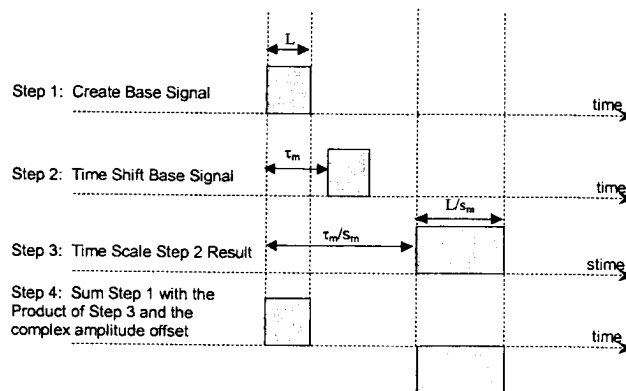

Figure 3 STORM Modulation

The offset signal can also be created by time scaling before applying the delay which changes the equations but leads to identical signal qualities. Also, the complex amplitude offset  $a_m$  can be a function of time in certain instances. This brief introduction only considers the constant value case however.

## STORM DEMODULATION

One STORM demodulation technique requires time scaling the received base signal to provide correlation with the received offset signal. Of course scaling the received offset signal to correlate with the received base signal is also possible. In Figure 4 the received signal is correlated with a delayed and time scaled version of itself. When the scale  $s_i$  matches the modulator scale  $s_m$ , a high degree of correlation is integrated at one or more lags.

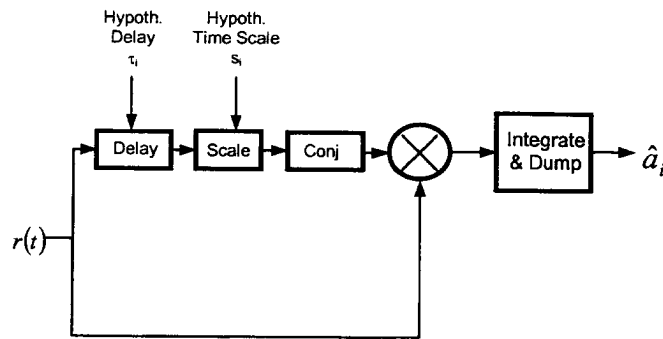

Figure 4 STORM Correlation Receiver

Defining a wideband auto ambiguity estimator [5] for  $x(t)$  from Figure 4:

$$\hat{\phi}_{xx}(t_o, s_i, \tau_i) = \frac{1}{T} \int_{t_o}^{t_o+T} x(t)x^*(s_i(t-\tau_i))dt$$

When the time scale,  $s_i$ , equals one this reduces to the previous autocorrelation estimator. The beginning of the hypothesized symbol period is  $t_o$  and the hypothesized scale-delay pair is defined by  $s_i$  and  $\tau_i$ . One or more estimates of the wideband auto-ambiguity function of  $x(t)$  may yield an estimate for  $a_m$ ,  $s_m$ , and  $\tau_m$ . One or more of these values contain the modulated information.

## STORM Quantified Performance Analysis

Based on the previous description of the STORM modulation and demodulation processes the performance is explained. Robust detection is achieved using relatively offset signals. This material is reviewed. Then STORM temporal resolution is derived. The temporal resolution drives processing rate requirements and communication synchronization estimate precision. The temporal resolution of STORM is compared to matched filtering and time offset modulation.

Finally multi-path reception is detailed. STORM is compared to matched filtering over a frequency selective channel.

Transmitted reference BER performance for the AWGN channel is clearly worse than coherent antipodal signaling schemes like DS-CDMA in terms of  $E_b/N_0$  since the reference waveform is also corrupted by noise. Stored reference systems, such as DS-CDMA, utilize a noise free reference signal at demodulator. Each time the TR symbol period is doubled the performance typically improves by 1.5 dB in terms of SNR when the AWGN channel is the dominant interference source. Thus TR methods can operate successfully at negative SNR's, but TR techniques offer poor efficiency in terms of  $E_b/N_0$  when compared to matched filtering for AWGN channels. The performance of TR methods has been analyzed for specific applications[2,3,4,6].

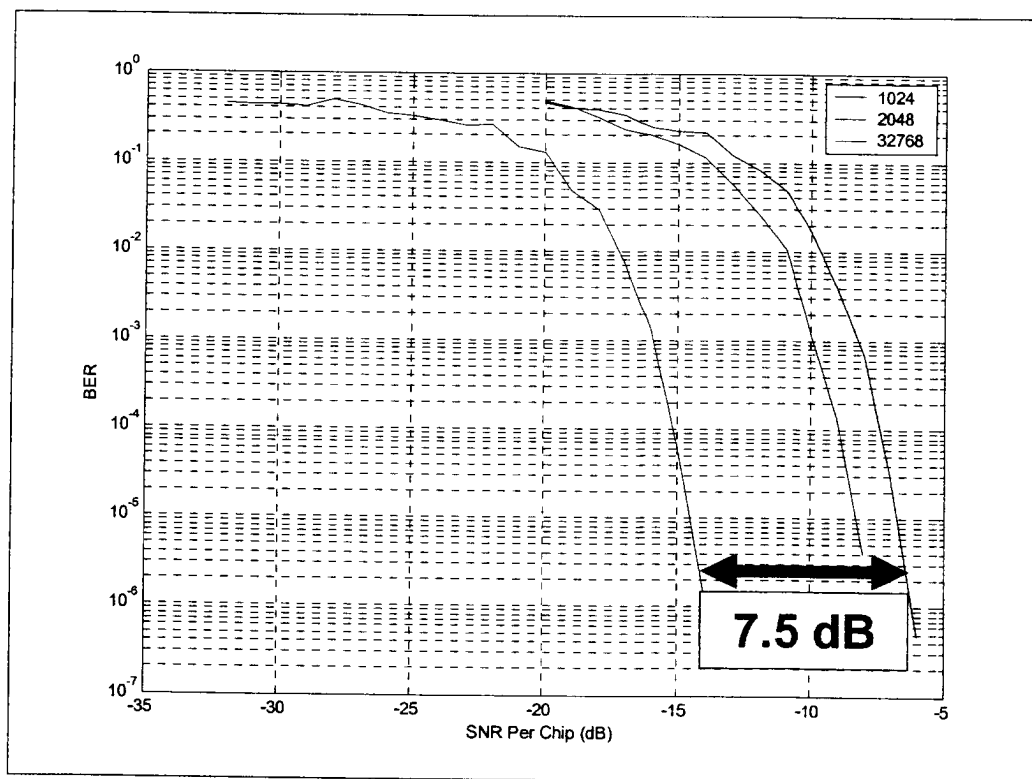
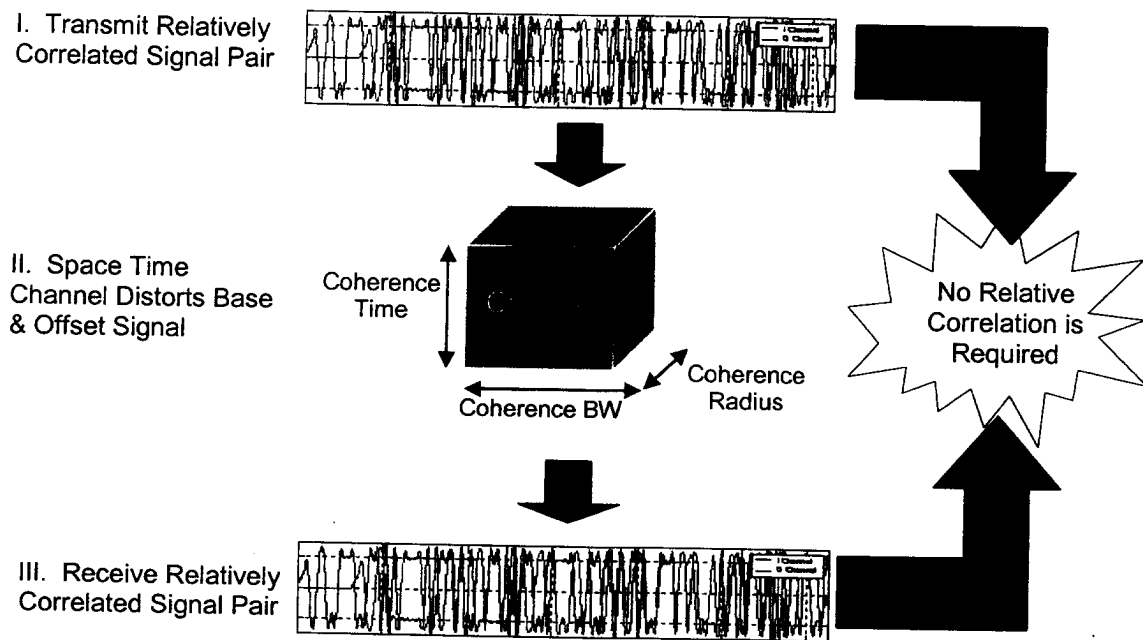

Figure 5 BER Performance for Spreading Ratios 1024, 2048, and 32768

## ROBUST DETECTION

Maximum correlation between the base and offset signal is maintained when each signal is distorted identically. For time-variant multi-path channels this condition is approximated when the scale is close to one and the delay offset is nearly zero, or equivalently the signals are highly overlapped in time and frequency. Therefore the base and offset signals are subject to relatively the same distortion. The figures depict exaggerated scales and delay offsets that are often too large but provide clear visualization. In practice, the base and offset signals are typically more highly overlapped especially when the symbol period exceeds the channel coherence time. The base and offset signals must be offset in time by less than the channel coherence time and offset in time scale by less than the channel coherence scale in order to maintain relative correlation between the received base and offset signals.



**Figure 6** Offset Signals Provide Robust Detection

Figure 6 illustrates robust detection with offset signals. First a pair of relatively offset signals are transmitted. The relatively correlated signals are shown in red and blue. The red signal is a copy of the blue signal that is delayed and time scaled. The relatively correlated signal pair propagates through the channel but the red and blue signals are distorted identically provided they are offset in time by less than the coherence time, in frequency by less than the coherence bandwidth, and in space by less than the coherence radius. The relatively correlated signals are received, but the received signals may have extremely weak correlation with the transmit signals. Reception is still robust since the receive signal shows a high degree of correlation when the received base signal is matched to the received offset signal.

Figure 7 illustrates three overlapped STORM signal examples. The upper signal is a highly overlapped STORM signal with an amplitude offset equal to 1. The second example is the same signal except the amplitude offset is -1. In this case the offset signal is inverted relative to the base.

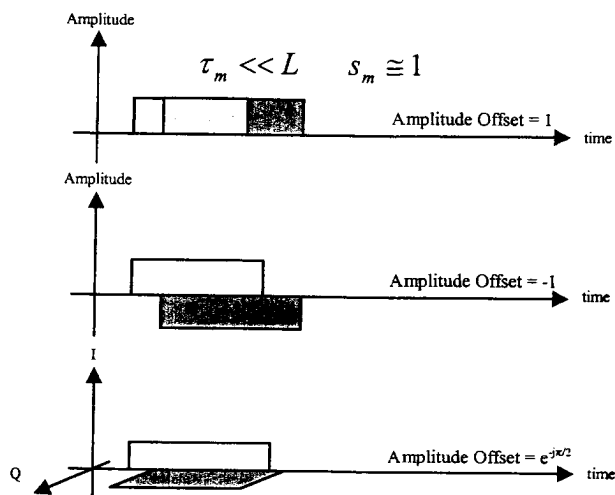

Figure 7 Visualizing Highly Overlapped STORM Signals

The third example depicts a STORM signal using a complex amplitude offset. In this case the base signal is transmitted orthogonally to the offset signal. The signals are shown on orthogonal carriers 'I' and 'Q'. In this case the base and offset signals are nearly completely overlapped in time and frequency and they are orthogonal. Since the base and offset are separated by a minimal amount of time and bandwidth, the received base and offset signals will maintain relative correlation after propagating through a rapidly time variant channel with a narrow coherence bandwidth.

## STORM's RAPID SYNCHRONIZATION

Synchronization enables efficient communication in the context of DSP resources, network capacity and often channel state information. Achieving synchronization normally requires the reception of a sounding sequence, training sequence, or beacon signal. If the desired signal has wide bandwidth and an extremely long period the signal detection process requires extreme processing capabilities. On the other hand, a narrowband and/or extremely short period signal is too simple to detect, jam, and exploit. STORM provides flexible temporal resolution which means wideband signals with long periods may be used for acquisition with completely adjustable processing requirements. STORM provides automatic non-coherent multi-path gain without estimating individual rake taps. These properties are attractive for HF-ALE radios and spread spectrum MANET's which may use conventional modulations in addition to the STORM channel sounding sequence or acquisition aid.

## Perfect Synchronization

Perfect demodulator synchronization requires exact knowledge of the signal arrival. Most practical applications cannot assume perfect synchronization but this case is a logical analytical starting point. Demodulation without perfect synchronization is developed later. Then, demodulator operation during multi-path reception is analyzed using multiple arrival times without perfect synchronization.

Figure 8 illustrates four signal processing steps performed by the demodulator from Figure 4. The top axis in Figure 8 depicts the received signal which is comprised of a base signal with duration 'L' and an offset signal that is delayed and scaled. The offset signal is scaled by  $s_m$  resulting in the duration  $L/s_m$ .

The second axis of Figure 8 depicts a delayed version of the received signal. On the third axis the demodulator time scales the delayed signal by  $s_m$ . The scaled signal base duration is now  $L/s_m$  while the offset signal duration is  $L/s_m^2$ .

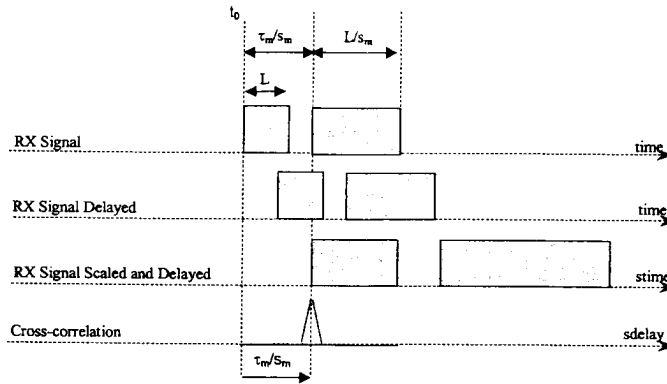

Figure 8 Synchronous Reception

The demodulator cross-correlates the received signal on the top axis with the signal on the third axis. The cross-correlation may be computed at all delays but one peak in the cross-correlation energy occurs when the time scaled received base signal aligns with the received offset signal and  $s$  equals  $s_m$ :

$$\hat{\phi}_{xx}(t_o, s_m, \tau) = \frac{a_m}{s_m} \hat{\phi}_{bb}(t_o, 1, s_m(\tau - \tau_m)) + a_m^* \hat{\phi}_{bb}(t_o, s_m^2, \tau + \frac{\tau_m}{s_m}) + \hat{\phi}_{bb}(t_o, s_m, \tau) + \frac{|a_m|^2}{s_m} \hat{\phi}_{bb}(t_o, s_m, s_m(\tau_m(\frac{1}{s_m} - 1) + \tau))$$

When the base chosen has wideband auto-ambiguity function side-lobes that are much less than the base signal energy:

$$\hat{\phi}_{xx}(0, s_m, \tau_m) \cong \frac{a_m}{s_m} \hat{\phi}_{bb}(0, 1, 0)$$

The cross correlation between the received signal and the correctly time scaled received signal peaks when  $\tau = \tau_m$ . The cross-correlation function is shown on the bottom axis of Figure 8 in a scaled reference frame. The cross-correlation peak magnitude provides an estimate of  $a_m$ .

## Asynchronous Reception

Typically the demodulator will not have perfect prior knowledge of the signal arrival time. Figure 9 illustrates the essential processing steps when the signal arrives  $d$  seconds late relative to the receiver time frame.

The top axis in Figure 9 is identical to the received signal in Figure 8 except the entire signal is delayed by  $d$  seconds:

$$x(t) = b(t - d) + a_m b(s_m(t - d - \tau_m))$$

First the received signal is delayed by  $\tau$ . Next, scaling the delayed signal by ' $s_m$ ' provides the signal shown on the third axis of Figure 9. Now the signal is delayed by  $d/s_m + \tau/s_m$ . The scaled base signal duration is  $L/s_m$  while the scaled offset signal duration becomes  $L/s_m^2$ . Next the demodulator cross-correlates the received signal with the delayed and time scaled received signal. A peak in the cross-correlation energy results when the delay is equal to  $\tau/s_m = \tau_m/s_m - d(1/s_m - 1)$ . Since the signal arrives at  $t_0$  but the estimator begins integration  $d$  seconds early. In term of the wideband auto-ambiguity estimate:

$$\hat{\phi}_{xx}(t_0 + d, s_m, \tau) = \frac{a_m}{s_m} \hat{\phi}_{bb}(t, 1, s_m(\tau - \tau_m + d(\frac{1}{s_m} - 1))) + a_m \hat{\phi}_{bb}(t, s_m^2, \tau + \frac{\tau_m}{s_m} + d(\frac{1}{s_m} - 1)) + \hat{\phi}_{bb}(t_0, s_m, \tau + d(\frac{1}{s_m} - 1)) + \frac{|a_m|^2}{s_m} \hat{\phi}_{bb}(t, s_m, s_m(\tau_m(\frac{1}{s_m} - 1) + \tau + d(\frac{1}{s_m} - 1)))$$

Perfect synchronization placed the cross-correlation peak at  $\tau_m$  while imperfect synchronization places the cross-correlation peak at  $\tau_m - (1/s_m - 1)d$ . When  $s_m$  is close to one,  $d$  has very little impact. When  $d$  is quite large the signal is still readily detected at a lag adjacent to  $\tau_m$  provided that a significant portion of the received signal energy is contained in the interval from  $t_0 + d$  to  $t_0 + d + T$  for successful detection.

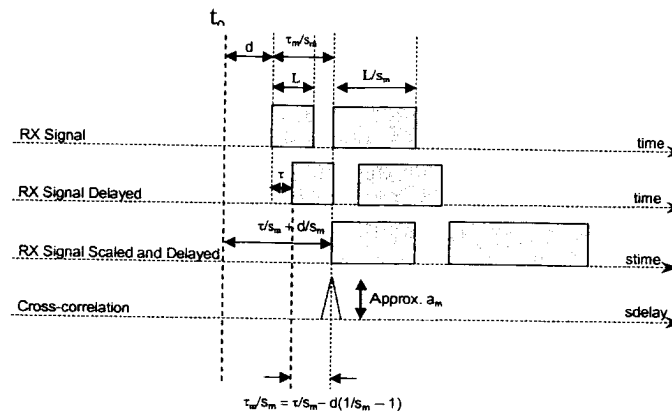
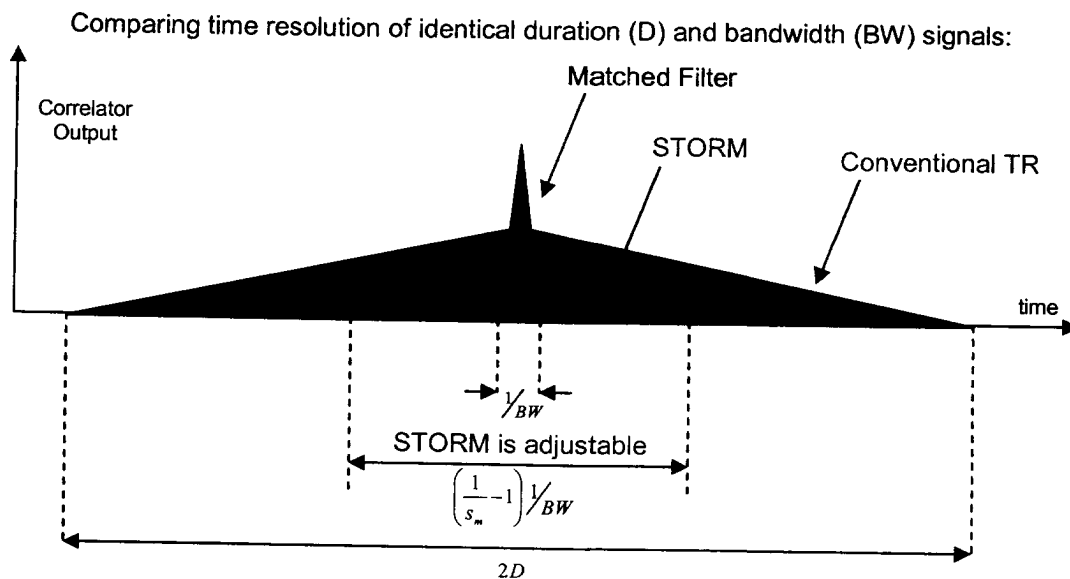

Figure 9 Unsynchronized Demodulation

Time scaling controls the effect of uncertain delay. Therefore the receiver processing rate is also effected by varying the time scale. Also, the delay spread over which multi-path energy is combined is also impacted by the time scale since multi-path reception can be described as multiple signal arrivals at uncertain delays. The receiver processing rate is also reduced by time scaling. The remaining sections explain processing rate and multi-path energy combination features in detail.

## STORM's REDUCED PROCESSING RATE

The STORM demodulator architecture provides instant synchronization for reliable signal detections. A synchronization error occurs when the demodulator begins processing the received signal at a time other than the exact time of arrival. Synchronization errors simply move the cross-correlation peak by  $(1/s_m - 1)d$ . The impact of a misaligned receiver hypothesis is reduced by  $(1/s_m - 1)$  which is a function of time scaling. More significant misalignment moves the peak cross correlation energy to an adjacent delay. Only  $(1/s_m - 1)L$  time-scaled cross-correlation lags must be computed each symbol duration to provide robust detection. When the scale is 0.999 the processing is about 1000 times less than matched filtering since approximately one cross-correlation must be computed for every one thousand received independent samples.



**Figure 10** Comparison of Time Resolution and Processing Rates

Figure 10 compares the temporal resolution of conventional transmitted reference, matched filtering, and STORM for signals with identical duration and bandwidth. Conventional TR provides resolution on the order of the signal duration. Therefore conventional TR provides little resolution and enables low processing rates. At the other extreme matched filtering temporal resolution is approximately the inverse signal bandwidth or chip period. Matched filtering provides high temporal resolution and therefore acquisition can be computationally intensive. STORM temporal resolution is a function of time scale. Setting the scale close to one approach conventional TR with low processing rate requirements and low temporal resolution. Moving the time scale farther from one increases the temporal resolution and increases the processing requirements until the temporal resolution approaches matched filtering.

STORM enables highly flexible temporal resolution and processing rate requirements without changing the signal bandwidth. Therefore wideband signals may be designed for any moderate temporal resolution and processing rate that is desired.

## MULTI-PATH RECEPTION

The previous section explained how STORM can trade-off temporal resolution and processing rate by changing the applied time scale. Now, Figure 11 illustrates the multi-path combination as a function of time scale. The time scale equals 0.9 in the top of this figure. This time scale independently resolves four paths at four distinct delays. Increasing the time scale to 0.99 produces the middle axis of Figure 11. In this case the energy from three paths with similar delays is stacked automatically while the fourth path remains distinct. Note that energy stacks and the relative phase of each path is irrelevant which will be derived subsequently. Finally the scale is increased to 0.999 which stacks even more multi-path energy. In this case all four paths are combined. Stacking energy from different multi-path delays is useful for communication applications. The individual delays and their relationship may be unknown yet the power is stacked. Increasing the time scale toward one decreases the temporal resolution, decreases the processing rate, and automatically stacks multi-path energy over increasing delay spreads.

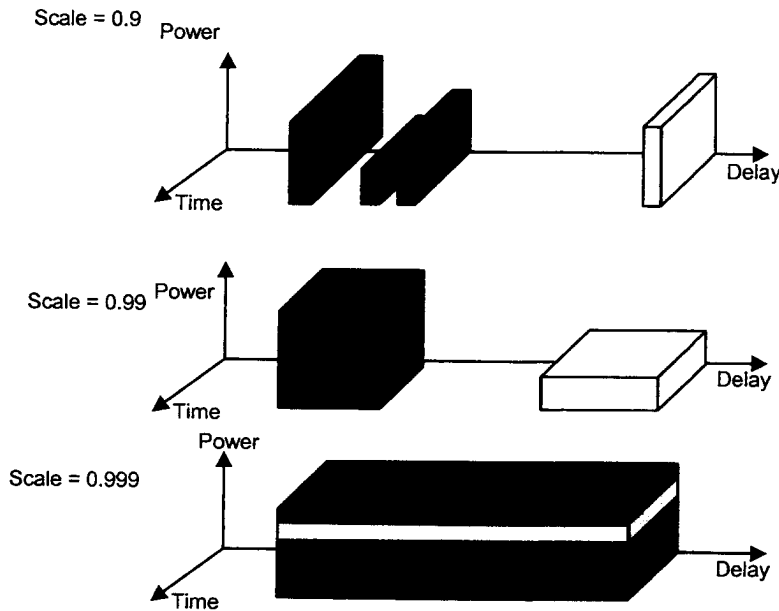

Figure 11 Flexible Multi-path Energy Stacking

Next the analytical basis for Figure 11 is examined. Multi-path propagation provides multiple signal arrival times. The simplest case involves two paths. Figure 11 illustrates the arrival of one STORM signal with complex path amplitude  $A_1$  which arrives  $d_1$  after the receiver expects the signal. A second STORM signal from another propagation path with complex amplitude  $A_2$  arrives  $d_2$  after the receiver expects the signal. Therefore the delay between the two paths must be  $d_2 - d_1$ .

Using the result from Figure 9, the first path causes a cross-correlation peak at  $\tau_m/s_m - d_1(1/s_m - 1)$ . Equivalently, the second propagation path causes a cross-correlation peak at  $\tau_m/s_m - d_2(1/s_m - 1)$ . The difference between these peaks is  $|(1/s_m - 1)(d_2 - d_1)|$ . The width of each peak is approximately the offset signal inverse bandwidth, see Figure 12.

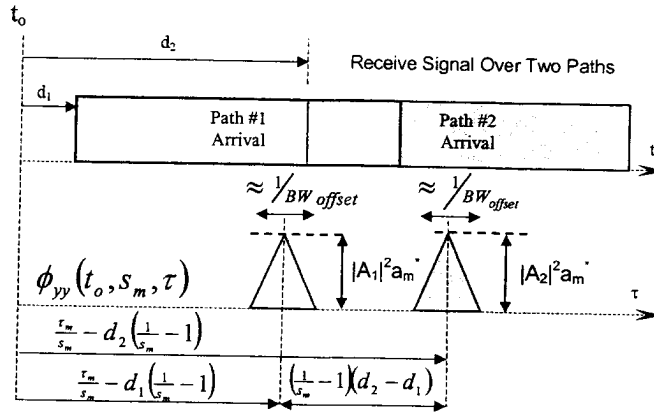

Figure 12 Multi-path Reception

When  $|(1/s_m - 1)(d_2 - d_1)|$  is greater than the offset signal inverse bandwidth, distinct peaks for each path exist in the cross-correlation function. Alternatively, when  $|(1/s_m - 1)(d_2 - d_1)|$  is less than the offset signal inverse bandwidth the cross-correlation energy from each path is stacked. The energy stacks since the correlation peaks are proportional to the magnitude squared of the respective path complex amplitude. The magnitude squared of a complex number is always positive and real.

In general, the STORM signal  $x(t)$  received over  $N$  paths each with complex magnitude  $A_i$  and delay  $d_i$  is  $y(t)$ :

$$y(t) = \sum_{i=1}^N A_i x(t - d_i)$$

The wideband auto-ambiguity estimate for  $y(t)$ ,

$$\hat{\phi}_{yy}(t_o, s, \tau) = \int_{t_o}^{t_o+T} \sum_{i=1}^N A_i x(t - d_i) \sum_{j=1}^N A_j^* x^*(s(t - d_j) - \tau) dt$$

The inter-path correlations are normally small when  $b(t)$  and  $s_m$  are chosen so that the auto-ambiguity function side lobes are small, thus:

$$\hat{\phi}_{yy}(t_o, s, \tau) \cong \int_{t_o}^{t_o+T} \sum_{i=1}^N |A_i|^2 x(t - d_i) x^*(s(t - d_i) - \tau) dt$$

which is the summation of WBAAF's for each resolvable path:

$$\hat{\phi}_{yy}(t_o, s, \tau) \cong \sum_{i=1}^N |A_i|^2 \hat{\phi}_{xx}(t_o + d_i, s, \tau)$$

Substituting:

$$\hat{\phi}_{xx}(t_o + d, s, \tau) = \frac{a_m}{s_m} \hat{\phi}_{bb}\left(t, 1, s_m \left(\tau - \tau_m + d \left(\frac{1}{s_m} - 1\right)\right)\right)$$

results in the WBAAF for the multi-path signal,

$$\hat{\phi}_{yy}(t_o, s, \tau) \cong \frac{a_m}{s_m} \sum_{i=1}^N |A_i|^2 \hat{\phi}_{bb}\left(t, 1, s_m \left(\tau - \tau_m + d_i \left(\frac{1}{s_m} - 1\right)\right)\right)$$

Thus the demodulator non-coherently combines, or rakes, the multi-path energy from the  $i^{\text{th}}$  and  $j^{\text{th}}$  path when:

$$\left| d_i \left( \frac{1}{s_m} - 1 \right) - d_j \left( \frac{1}{s_m} - 1 \right) \right| < \frac{1}{BW_{offset}}$$

When this magnitude is greater than the offset signal inverse bandwidth the detected lag is resolved in an adjacent delay bin.

## Matched Filter Receiver

The matched filter receiver is used in the optimum receiver for the AWGN channel. Multi-path channels are either flat fading or frequency selective. Flat fading channels are normally narrowband while WLAN applications utilize broadband channels that are frequency selective [7]. Multi-path propagation cannot improve matched filter performance since the received signal no longer matches the transmitted signal.

Provided the signal is received with average power  $|A_1|^2$  and  $\|c\|^2$  is the spreading ratio or norm of the matched filter vector with elements from  $\{-1,+1\}$ , the matched filter output SNR of an antipodal binary transmission over the AWGN channel is derived in [8]:

$$\left( \frac{S}{N} \right)_{MF} = \frac{|A_1|^2 \|c\|^2}{N}$$

If received signal  $y(t)$  arrives over  $N_p$  paths and the receiver introduces AWGN:

$$y(t) = \left( \sum_{k=1}^{N_p} A_k e^{j\phi_k} x(t - \tau_k) \right) + n(t)$$

Each path has a random magnitude and random phase which is uniformly distributed on  $[0, 2\pi)$ . Using a spread spectrum technique each of the  $N_p$  paths may be resolved provided two paths never arrive within one chip period. When this does occur a particular delay will experience fading. Assuming resolvable paths simplifies the following equations and provides a useful performance upper bound. This can be used to demonstrate that resolvable multi-path propagation degrades matched filter performance but improves STORM performance.

The performance in this multi-path channel may be computed assuming that the interference from each path is Gaussian [9]. First, the signal to interference ratio is the ratio of the power received over one path,  $|A_1|^2$ , to the power of the  $N_p-1$  other received paths plus the power of AWGN,  $N$ , at the receiver:

$$\left( \frac{S}{N+I} \right)_o = \frac{|A_1|^2 \|c\|^2}{N + \sum_{k=2}^{N_p} |A_k|^2}$$

where  $\|c\|^2$  is the norm of the matched filter response vector and  $A_1$  is the average received amplitude per path. Increasing the number of resolvable multi-paths degrades performance since the additional power adds to the noise power in the denominator. Of course more sophisticated demodulators exist such as coherent or non-coherent rake demodulators [10]. Rake demodulators require more computation and the demodulator must correctly hypothesize the

proper waveform signature and each correct multi-path delay to sub-chip accuracy. This adds cost and complexity which becomes even worse if the multi-path is time variant.

## STORM Demodulator

The STORM demodulator follows the performance of transmitted reference systems for the AWGN channel is derived in [8]:

$$\left(\frac{S}{N}\right)_{TR} = \frac{\|c\|^4}{N(N+2\|c\|^2)}$$

Multi-path propagation creates the signal  $c'$  which is the convolution of the transmit waveform with the channel impulse response. The STORM correlator output SNR can be defined for a multi-path channel:

$$\left(\frac{S}{N+I}\right)_{TR} = \frac{\|c'\|^4}{N(N+2\|c'\|^2)}$$

Applying the multi-path channel model for  $c'$ :

$$\left(\frac{S}{N+I}\right)_{TR} = \frac{\left(\|c\|^2 \sum_{i=1}^{N_p} |A_i|^2\right)^2}{N\left(N+2\|c\|^2 \sum_{i=1}^{N_p} |A_i|^2\right)}$$

When  $N$  is large:

$$\left(\frac{S}{N+I}\right)_{TR} \cong \frac{\left(\|c\|^2 \sum_{i=1}^{N_p} |A_i|^2\right)^2}{N^2} \quad \text{Large Noise Case}$$

When  $N$  is small:

$$\left(\frac{S}{N+I}\right)_{TR} \cong \frac{\|c\|^2 \sum_{i=1}^{N_p} |A_i|^2}{N} \quad \text{Small Noise Case}$$

In each case the multi-path energy adds in the numerator. Therefore, the STORM correlation output SNR is proportional to the sum of received resolvable multi-path energy. Resolvable multi-path improves STORM performance. Note that the border between the small noise and large noise case is a function of the spreading ratio and the noise power.

## Comparing STORM and Matched Filtering Output SNR

While the matched filter can achieve optimum performance for an AWGN channel, the STORM correlator compares well when the channel provides multi-path propagation. First, the STORM correlator output SNR may be expressed in terms of the matched filter output as derived in [8]:

$$\left(\frac{S}{N}\right)_{TR} = \left(\frac{S}{N}\right)_{MF} \left(\frac{1}{2 + \frac{N}{\|c\|^2}}\right)$$

Clearly the STORM correlator output SNR will be worse than a matched filter for the AWGN channel. This is expected since matched filtering is optimal for the AWGN channel. Most practical wireless applications utilize multi-path channels.

In the presence of multi-path there are two cases. If  $N^2 \ll 2N\|c\|^2$ , then:

$$\left(\frac{S}{N+I}\right) \cong \left(\frac{S}{N}\right)_{MF} \sum_{i=1}^{N_p} |A_i|^2 \quad \text{Small Noise Case}$$

Therefore the STORM correlator output SNR improves by the sum of multi-path magnitudes squared compared to matched filtering in the presence of only AWGN. When  $N^2$  is much greater than the total multi-path energy times the norm of  $c$ , then:

$$\left(\frac{S}{N+I}\right)_{TR} = \left(\frac{S}{N}\right)_{MF}^2 \left(\sum_{i=1}^{N_p} |A_i|^2\right)^2 \quad \text{Large Noise Case}$$

In this case the STORM correlator output signal to noise ratio is still improved by adding multi-path energy. However, the output SNR of the STORM correlator is now proportional to the matched filter output SNR squared. Since this is proportional to the matched filter output SNR squared, increasing the spreading ratio enables operation at increasingly negative input SNR's which illustrates process gain. Increasing the spreading ratio directly increases the norm of  $c$ . When received noise power dominates received multi-path energy the channel is approximately AWGN so the matched filter delivers much higher output SNR than the STORM correlation.

## Multi-path Summary

STORM combines multi-path energy to improve detection performance. Conventional matched filtering typically acquires each path individually, although the paths may be combined after acquisition. STORM may combine multi-path energy over a short delay spread when the scale is 0.99 to 0.9 or it can combine multi-path energy over a substantially longer delay spread when the scale is close to one. Frequency selective multi-path improves the STORM correlator output SNR whereas the matched filter output SNR includes frequency selective multi-path components in the noise energy.

## Applications

STORM could overlay DS-CDMA signal to simplify acquisition. This could be applied in a DS-CDMA modem, MANET application, or HF ALE system.

### **STORM Assisted Communication Acquisition**

STORM could be used to assist the acquisition of conventional DS-CDMA signals. Figure 10 illustrated that DS-CDMA signals have very high temporal resolution since the inverse bandwidth is very small. Consequently the matched filter receiver must hypothesize PN sequence alignment very often to acquire this signal. Figure 10 also shows the variable temporal resolution STORM

characteristic. Choosing a scale around 0.99 provides temporal resolution of about one hundred chips. In this case the STORM detector only makes one hypothesis for every one hundred chip periods whereas the matched filter must make at least one hundred hypotheses for every one hundred chip periods.

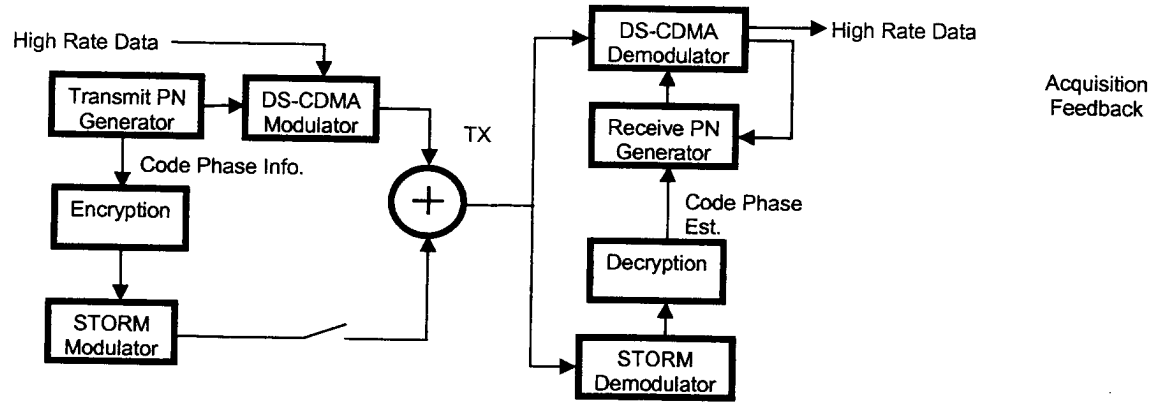
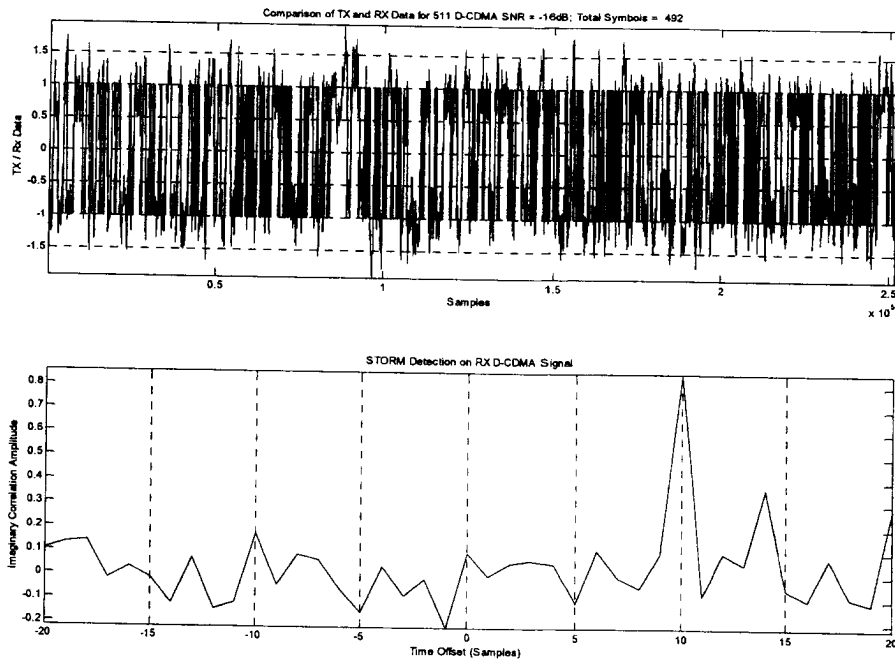

Figure 13 STORM Assisted DS-CDMA Acquisition

It may be advantageous to overlay a STORM signal on a DS-CDMA transmission to assist acquisition, see Figure 13. Consider an example case where a BPSK DS-CDMA signal is the STORM base signal. If the receiver magically hypothesizes the correct PN code phase, both the DS-CDMA signal and the STORM signal are detected. The top of Figure 14 illustrates the transmitted data in blue and the depredd receive data in red. There is an excellent match, so the BER is low. The bottom of Figure 14 shows a simultaneous STORM detection on this signal with 0.99 as the time scale. The peak occurs at  $\tau = 10$ .



**Figure 14** Simultaneous Detections with Perfect Synchronization

Since many receivers lack prior precision synchronization information, typically the first hypothesized PN phase will not match the received signal. In Figure 15 the transmit data is once again shown in blue while the despread receive data is shown in red. The receive data is just noise since the receiver PN sequence is not aligned with the received signal. No additional information is provided so the receiver searches for a new alignment. This blind search could be repeated millions to billions of times. Fortunately embedding the STORM signal in this transmission provides additional information to reduce the search space substantially. The bottom of Figure 15 shows a simultaneous STORM detection on the received signal with time scale equal to 0.99 at  $\tau = 9$ . Given this scale and delay detection and prior information about codebook used to encrypt code phase onto the STORM signal this detection instructs the receiver to advance the PN search approximately one hundred chips.

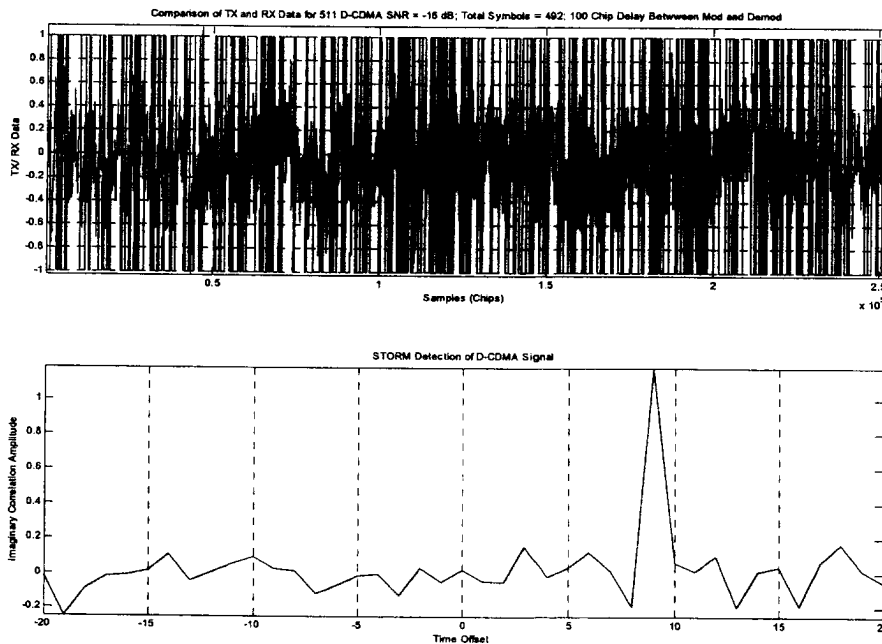

**Figure 15** STORM Detection with 100 Chip Misalignment

In this application STORM provides a method to acquire the DS-CDMA signal at a much lower processing rate. Lower processing rates provide less temporal resolution and the system designer can elect to choose the time scale that provides a small but computationally manageable search space. Finally, resolvable multi-path energy is discovered in separate applications of the matched filter. Normally rake receivers are used to combine energy from resolvable multi-path, but each path is usually acquired individually. STORM detection non-coherently rakes multi-path energy which means acquisition can process all received energy and maintain a comparatively low processing rate.

## CONCLUSION

Scale Time Offset Robust Modulation is an extension of TR spread spectrum modulation techniques. STORM may utilize a wide variety of base signals including random noise and conventional communication signals. STORM provides instant synchronization communications, automatic selectable multi-path energy combination, and processing rates which are often orders of magnitude lower than matched filtering when the time scale parameter is known in advance. This is delivered at the expense of  $E_b/N_0$  performance. Since STORM may be used with a variety of base signals the technique may be applied as a robust modulation technique or the STORM signal may be used to acquire synchronization on a higher data rate signal.

This foundational analysis indicates that STORM could find useful applications in DS-SS or other systems that require simplified acquisition. STORM can be used as a modulation technique for robust low rate communication over radio channels with little coherence, or it could overlay a high rate signal to assist with recognition and synchronization.

## REFERENCES

- [1] Simon, Marvin K., Omura, Jim K., Scholtz, Robert A., Levitt, Barry K., *Spread Spectrum Communications Handbook*, p. 9, McGraw-Hill, Inc., New York, 1994.
- [2] Batani, N.; Performance Analysis of Direct Sequence Spread Spectrum with Transmitted Code Reference, *Proceedings of the 32nd Midwest Symposium on Circuits and Systems*, Aug 1989, Vol. 2, pp. 731 -735.
- [3] Batani, N.; Performance Analysis of Direct Sequence Spread Spectrum System with Transmitted Code Reference on Quadrature Carrier, *Proceedings of the 34th Midwest Symposium on Circuits and Systems*, May 1991, Vol.1, pp. 239-244.
- [4] Kennedy, Michael Peter; Kolumbán, Géza; Kis, Gábor; Jákó, Zoltán; Performance Evaluation of FM-DCSK Modulation in Multipath Environments, *IEEE Transactions on Circuits and Systems*, December 2000, Vol. 47, No. 12, pp. 1702 – 1711
- [5] Young, Randy, K., *Wavelet Theory and its Applications*, Boston, MA: Kluwer Academic Publishers, 1993.
- [6] Hoober, Ralph; Tomlinson, Harold; Delay Hopped Transmitted Reference RF Communications, 2002 IEEE Conference on UWB Systems and Technologies, pp. 265-269.
- [7] Durgin, G.D.; Kukshya, V.; Rappaport, T.S.; Wideband Measurements of Angle and Delay Dispersion for Outdoor and Indoor Peer-to-peer Radio Channels at 1920 MHz, *Antennas and Propagation, IEEE Transactions on*, Volume: 51 Issue: 5, May 2003, pp. 936-944.
- [8] Gagliardi, A Geometrical Study of Transmitted Reference Communication Systems, *IEEE Transactions on Communication Technology*, Volume: 12 Issue: 4, Dec 1964, pp. 118-123

[9] Proakis, J.G., *Digital Communications*, New York: McGraw-Hill, 1996, pp. 716-717.

[10] Rappaport, T.S., *Wireless Communications*, Upper Saddle River, NJ, 1996, pp.336-338.

## **APPENDIX**

Three STORM IEEE publications