

**Captain
Per Brodd
UAV-Mission commander**



**Life regiment hussars K3
Past five years with UAVs
10 years in the Signal Corps**

Tel: +46505451276

mobile: +46706734309

per.brodd@k3.mil.se

Report Documentation Page

Form Approved
OMB No. 0704-0188

Public reporting burden for the collection of information is estimated to average 1 hour per response, including the time for reviewing instructions, searching existing data sources, gathering and maintaining the data needed, and completing and reviewing the collection of information. Send comments regarding this burden estimate or any other aspect of this collection of information, including suggestions for reducing this burden, to Washington Headquarters Services, Directorate for Information Operations and Reports, 1215 Jefferson Davis Highway, Suite 1204, Arlington VA 22202-4302. Respondents should be aware that notwithstanding any other provision of law, no person shall be subject to a penalty for failing to comply with a collection of information if it does not display a currently valid OMB control number.

1. REPORT DATE 02 SEP 2003		2. REPORT TYPE N/A		3. DATES COVERED -	
4. TITLE AND SUBTITLE Ugglan Update				5a. CONTRACT NUMBER	
				5b. GRANT NUMBER	
				5c. PROGRAM ELEMENT NUMBER	
6. AUTHOR(S)				5d. PROJECT NUMBER	
				5e. TASK NUMBER	
				5f. WORK UNIT NUMBER	
7. PERFORMING ORGANIZATION NAME(S) AND ADDRESS(ES) Swedish Defence Forces				8. PERFORMING ORGANIZATION REPORT NUMBER	
9. SPONSORING/MONITORING AGENCY NAME(S) AND ADDRESS(ES)				10. SPONSOR/MONITOR'S ACRONYM(S)	
				11. SPONSOR/MONITOR'S REPORT NUMBER(S)	
12. DISTRIBUTION/AVAILABILITY STATEMENT Approved for public release, distribution unlimited					
13. SUPPLEMENTARY NOTES See also ADM001676, UAV 2002 Conference & Exhibition., The original document contains color images.					
14. ABSTRACT					
15. SUBJECT TERMS					
16. SECURITY CLASSIFICATION OF:			17. LIMITATION OF ABSTRACT	18. NUMBER OF PAGES	19a. NAME OF RESPONSIBLE PERSON
a. REPORT unclassified	b. ABSTRACT unclassified	c. THIS PAGE unclassified			

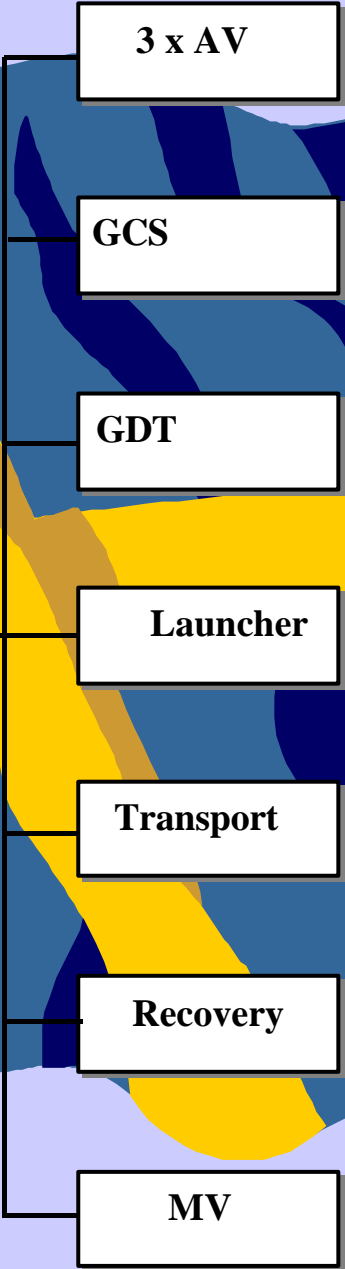
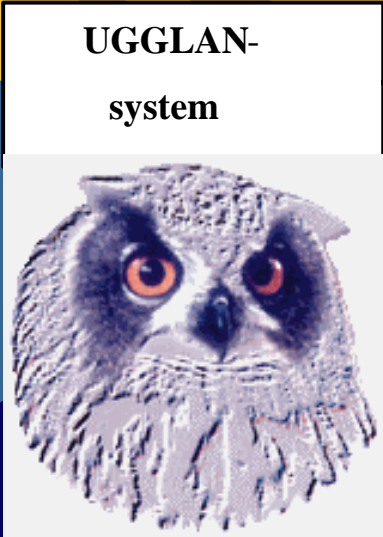

Ugglan update

68 flights

110 hours

Flight conditions:

-30 to + 20 C

No crashes or de

One hard landing after engine failure

One AV dragged in the parachute, due to a malfunction in the parachute releaser.



UAV Flight Areas today

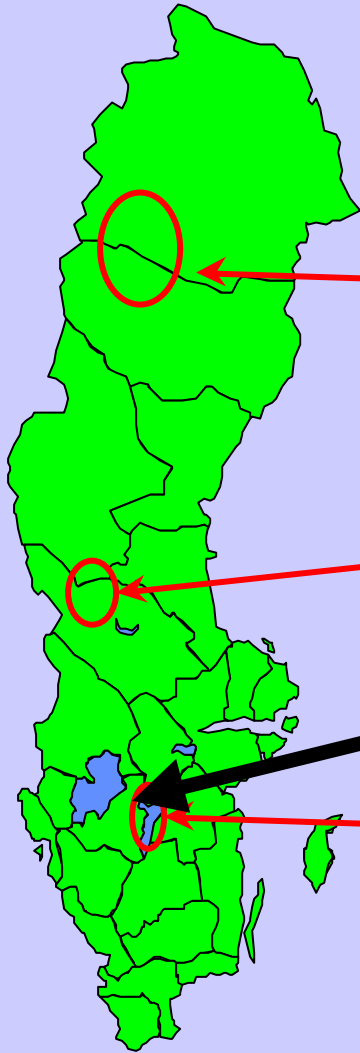

**Vidsel (FMV Test Range,
40 x 100 km) 44 flights**



UGGLAN

Sensor to Shooter



Command and order process.

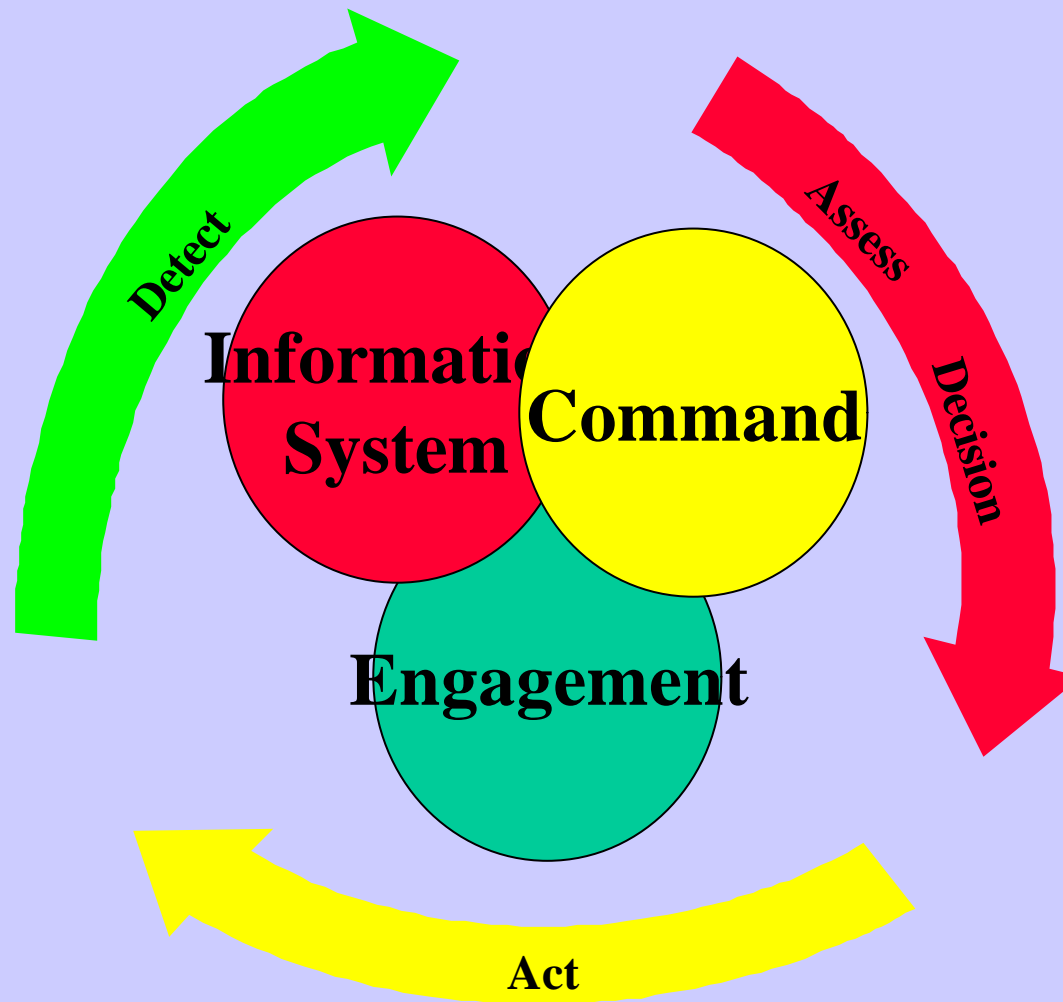

Priority list

1. HQ
2. Artillery
3. Armoured bn
4.

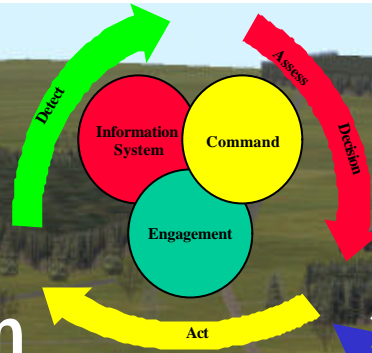

Intel Rep
BDA rep

Adjustment
Order Fire Mission



- 20 to -28 deg C



Windy



1.2 m snow



**Arctic
Conditions**

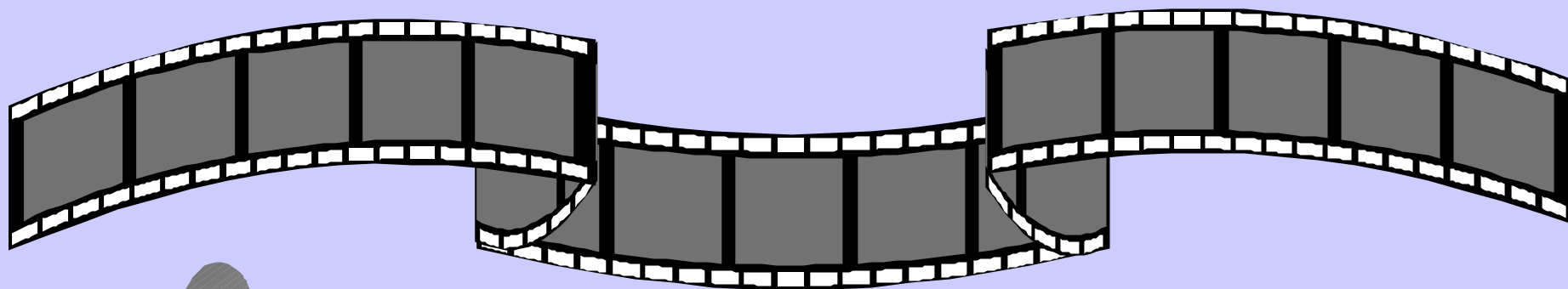

SANSON TO SHOOT

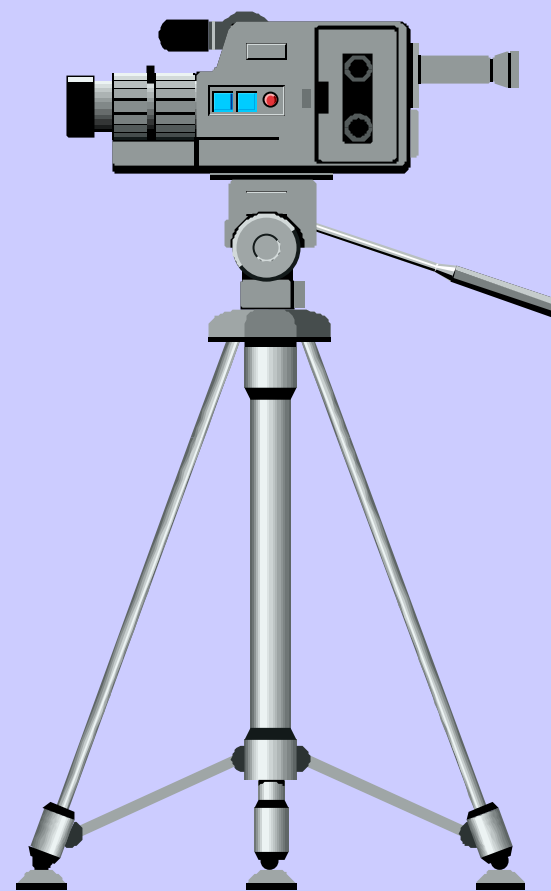

Operational experience / Lessons learned

From target detection to impact 3 min

1 min- Target detection and filling in artillery formats

1 min- Transmission, loading and aiming

1 min - Ballistic phase

Accuracy: A number of
with varying CEP values
than one fire adjustment

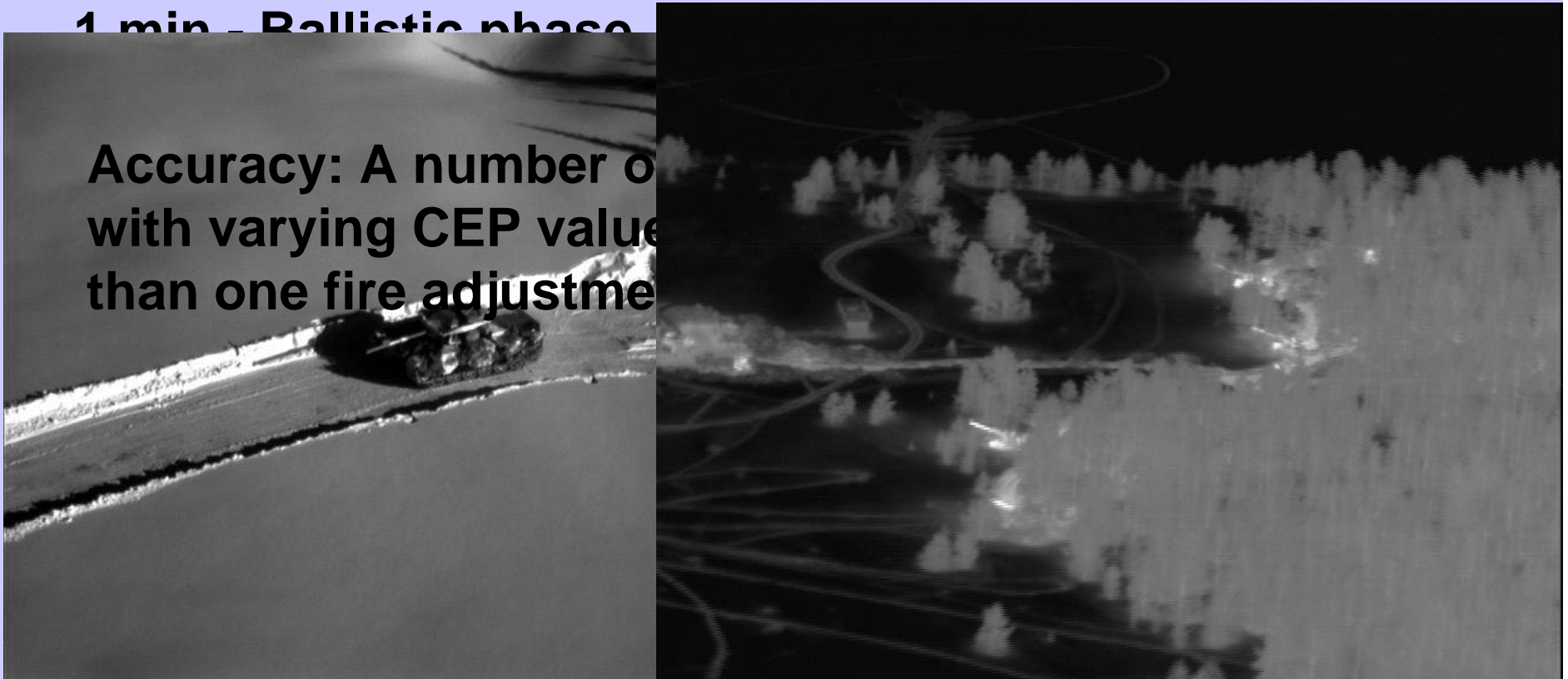

Method:

Acquire the coordinates of the target (with as good CEP as possible).

Move the AV away while the coordinates are transmitted, in order to be in a favourable position, upon impact.

Set FOV to WIDE in order to be able to have the target in view, as well as the impact bursts.

Make necessary adjustment, or if the first result was good, perform BDA.

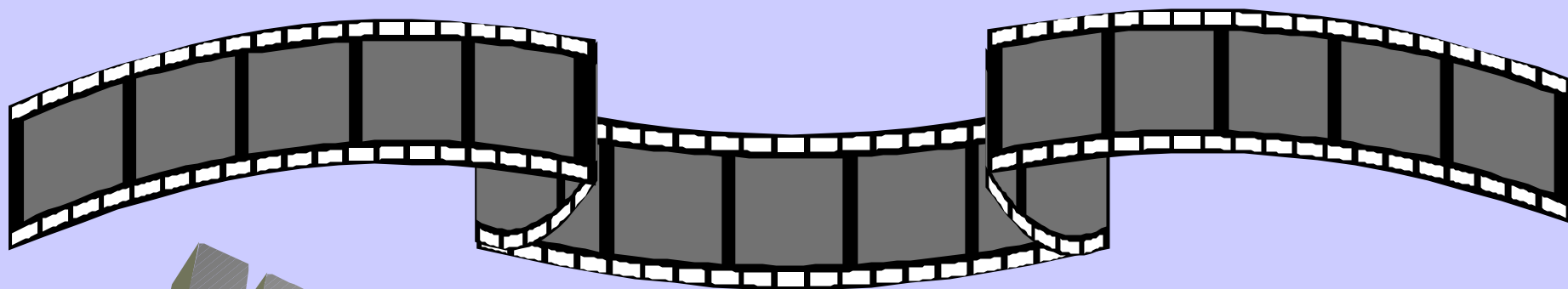

Video Production

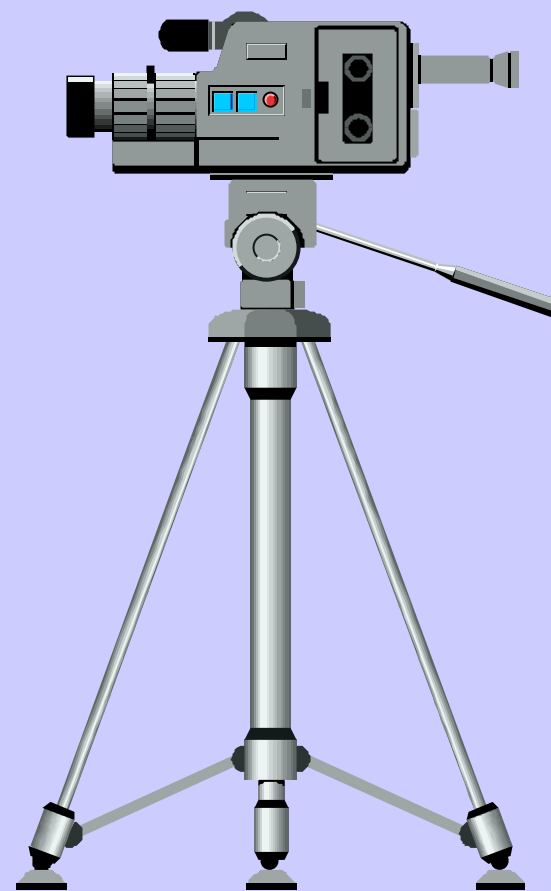

Mine detection

Tests in snow and on bare ground, with mines that have been on the site for several days, have been made.

Results: Mines on roads or in open terrain is no problem to detect, whether it is snow or not.

Detecting mines in the snow or in terrain with lot of stones and/or small bushes, or terrain with foliage cover is very difficult or even impossible.

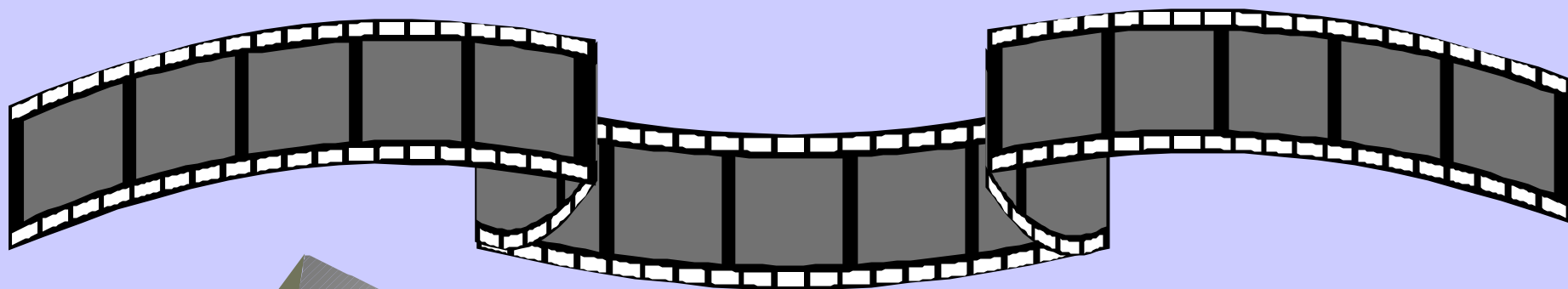

LEGIONS

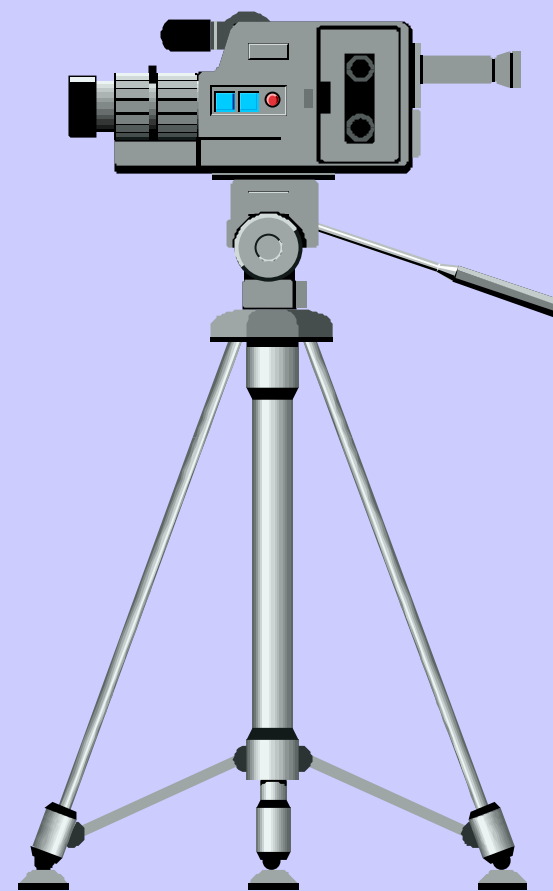

Decoys

These decoys were detected due to lack of :

- additional and personnel equipment.**
- heat signature on wheels.**
- antennas.**
- etc.**

Other means of detecting decoys is:

- Track picture (or lack of...)**

Effect of decoys:

- Time delay**

In order to be effective, decoys needs to be as detailed as possible, in all spectra.

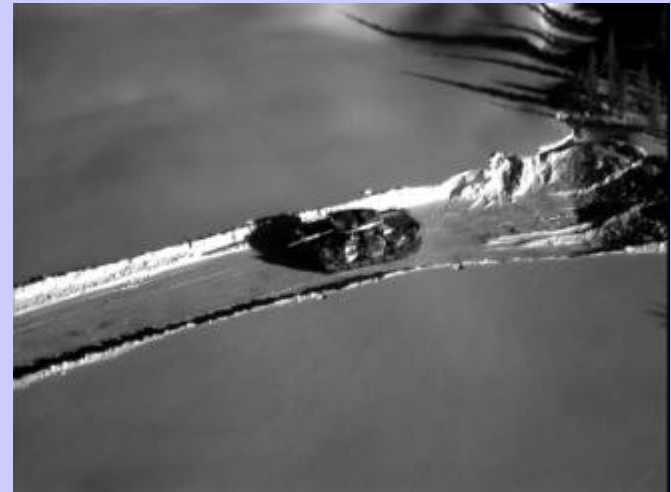

Radiac sensor

During the PfP exercise “Barents Rescue” (Sep 2001), one AV was equipped with a radiac sensor and measurements were sent to the SSI (the Swedish Radiation Institute) using an ordinary GSM telephone and then presented on the Internet, as shown in the picture.

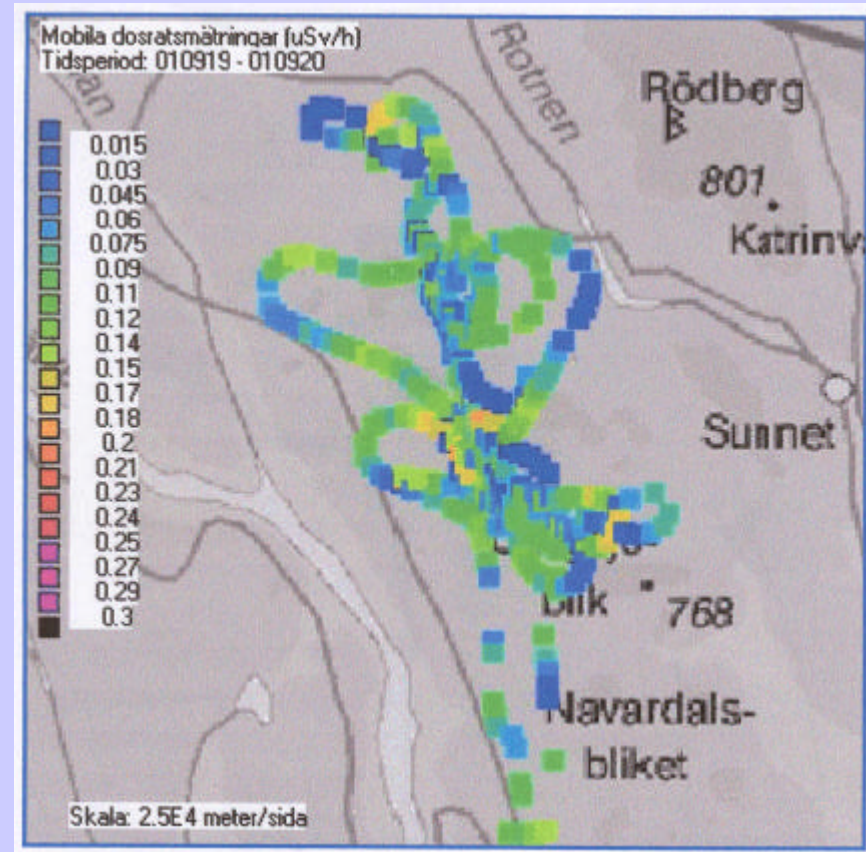

Lessons learned - General

A UAV is not a sensor system, it is a flying system with a multirole capability.

It costs money and time in terms of:

- maintenance**
- airworthiness**
- documentation**
- spare parts**
- operator training (pilots, mission commanders,
sensor operators and technicians)**

General acceptance of unmanned systems?

Unmanned = Uncontrollable = Unreliable

Airworthy?

QUESTIONS?

