

# Joint Unmanned Aerial Vehicles Joint Test & Evaluation

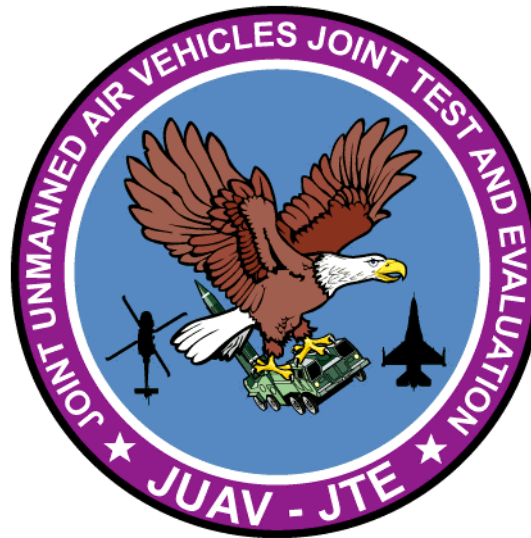

Presenter: CAPT Roy Rogers  
775-426-4653

# Report Documentation Page

*Form Approved*  
*OMB No. 0704-0188*

Public reporting burden for the collection of information is estimated to average 1 hour per response, including the time for reviewing instructions, searching existing data sources, gathering and maintaining the data needed, and completing and reviewing the collection of information. Send comments regarding this burden estimate or any other aspect of this collection of information, including suggestions for reducing this burden, to Washington Headquarters Services, Directorate for Information Operations and Reports, 1215 Jefferson Davis Highway, Suite 1204, Arlington VA 22202-4302. Respondents should be aware that notwithstanding any other provision of law, no person shall be subject to a penalty for failing to comply with a collection of information if it does not display a currently valid OMB control number.

1. REPORT DATE <b>02 SEP 2003</b>	2. REPORT TYPE <b>N/A</b>	3. DATES COVERED <b>-</b>	
4. TITLE AND SUBTITLE <b>Joint Unmanned Aerial Vehicles Joint Test &amp; Evaluation</b>		5a. CONTRACT NUMBER	
		5b. GRANT NUMBER	
		5c. PROGRAM ELEMENT NUMBER	
6. AUTHOR(S)		5d. PROJECT NUMBER	
		5e. TASK NUMBER	
		5f. WORK UNIT NUMBER	
7. PERFORMING ORGANIZATION NAME(S) AND ADDRESS(ES) <b>JUAV/JTE, USA</b>		8. PERFORMING ORGANIZATION REPORT NUMBER	
9. SPONSORING/MONITORING AGENCY NAME(S) AND ADDRESS(ES)		10. SPONSOR/MONITOR'S ACRONYM(S)	
		11. SPONSOR/MONITOR'S REPORT NUMBER(S)	
12. DISTRIBUTION/AVAILABILITY STATEMENT <b>Approved for public release, distribution unlimited</b>			
13. SUPPLEMENTARY NOTES <b>See also ADM001676, UAV 2002 conference &amp; Exhibition., The original document contains color images.</b>			
14. ABSTRACT			
15. SUBJECT TERMS			
16. SECURITY CLASSIFICATION OF:			17. LIMITATION OF ABSTRACT
a. REPORT <b>unclassified</b>	b. ABSTRACT <b>unclassified</b>	c. THIS PAGE <b>unclassified</b>	<b>UU</b>
			18. NUMBER OF PAGES <b>15</b>
			19a. NAME OF RESPONSIBLE PERSON



# Briefing Contents

---

- **NAS Fallon History/Missions**
- **JT&E Basics**
- **UAV Problem Background**
- **Our Proposed Test**
- **Our Legacy**



# Where is Fallon and why is the Navy in Nevada?





# **NAS Fallon**

## **Missions/Functions**

---

- **USN/Fallon history dates to 1942**
- **STRIKE U/Air Wing Training in 1984**
- **NSAWC (Naval Strike & Air Warfare Center) established July '96 with merger of "STRIKE", "TOPGUN", "TOPDOME"**
- **Primary authority for graduate level aviation strike warfare training**
  - \* Air Wing Training
  - \* Individual Training
- **Real World Operational Support**
- **3000 Pers, 68 AC, 42K Sorties/Year**



# Range Ops/Capability

---

- **57 Threat Systems - Operators in the loop**
- **Tracking/Instrumentation (TACTS)**
- **FAA Waiver for UAVs**
- **6.5 million acres, 600 people**





# “JTE 101”

---

- **Chartered by OSD Acquisition, Tech & Logis. (ATL) Senior Advisory Council (SAC)**
  - 5 SES-5s from OSD
  - 6 Flag/General Officers (1/2 star)
- **“Do better with what we have”**
  - Joint Tactics, Techniques & Procedures
  - Lead service commits for infrastructure
  - All services commit for people
  - Typically a 3 year test – Approx \$13M
- **8 JTEs in existence (JUAV plus:)**
  - Theater Distribution
  - Close Air Support
  - Ship/Helo Integration
  - BDA
  - GPS Countermeasures
  - Cruise Missile Defense
  - C2ISR



# Why a Joint Test?

---

- **USA Initiatives**
  - Hunter Stand-off Killer Team (HSKT) ACTD
  - Shadow OpEval/IOC
- **USN/USMC Initiatives**
  - UAV/Air Wing TACD&E
  - Pioneer/USMC (CAX)
- **AF Initiatives**
  - Predator Hellfire Demo
  - Hunter Night CAS Demo
  - FAC/A Role (15th RS)





## **JUAV - JTE Test Objective:**

# **Develop Joint Tactics, Techniques and Procedures for UAVs in a Tactical Role**

### **Standardized**

- **Command & Control**
- **Deconfliction**
- **Target Designation**
- **Mission Procedures**





# JUAV-JTE Focus

---

- **Tactical and above classes of vehicles**  
(No micro, mini, small)
- **Mission Areas**
  - **Air Interdiction/Armed Reconnaissance**
  - **Fire Support**
  - **Special Operations (NEO and CSAR)**

**Tactical**



**MAE**



**HAE**





# JUAV Test Concept

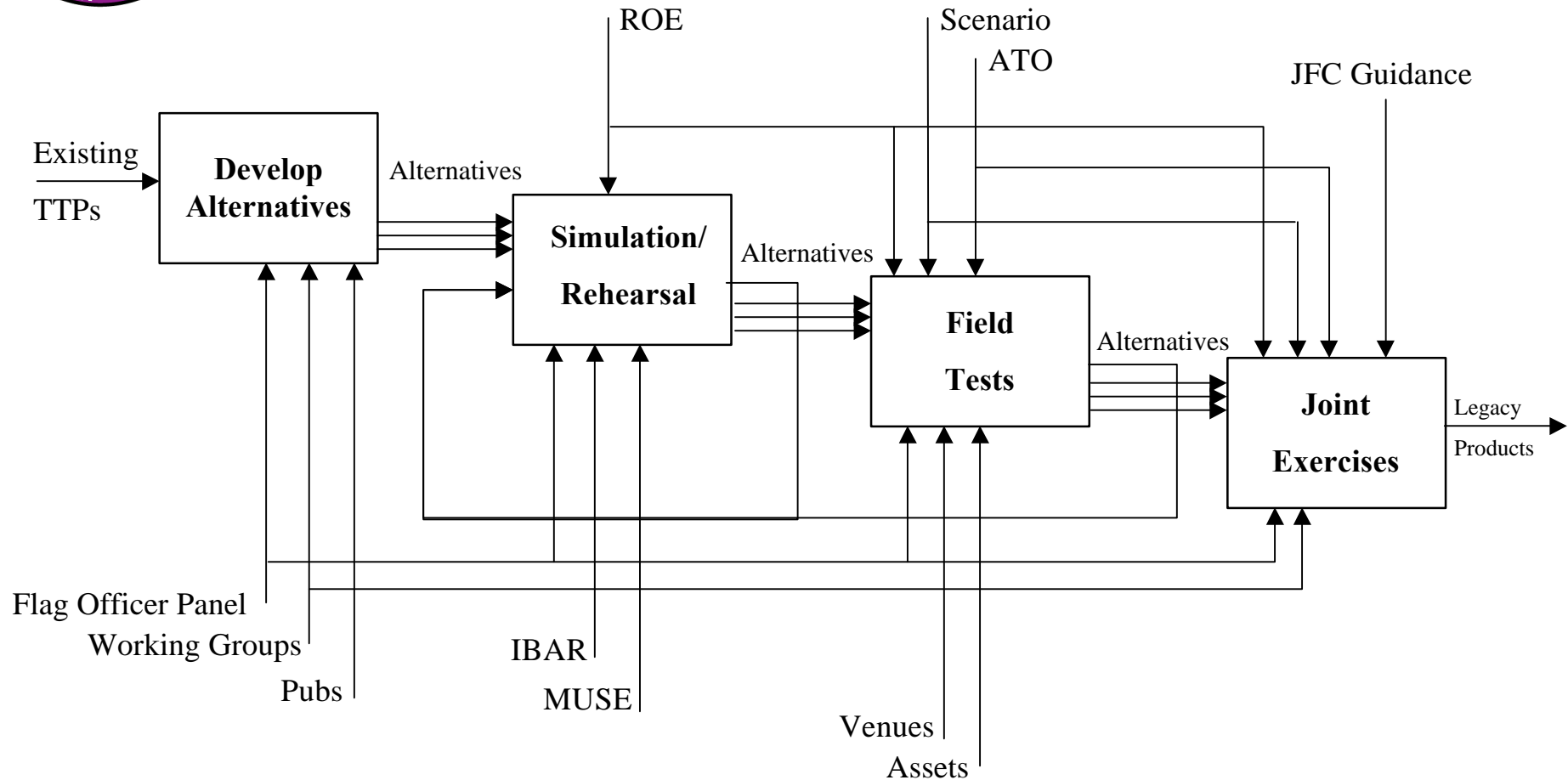



# Test Schedule

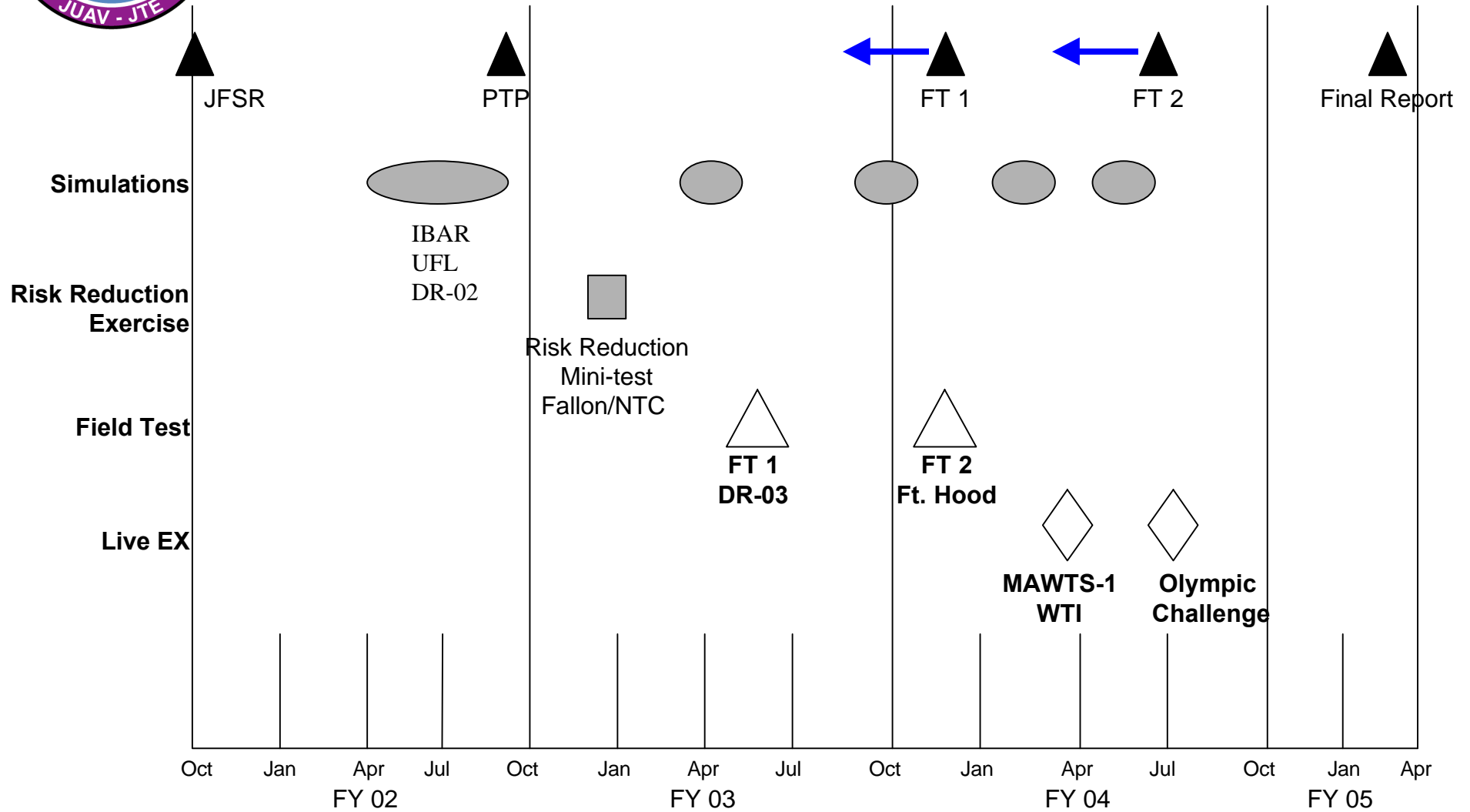



# OEF UAV C2

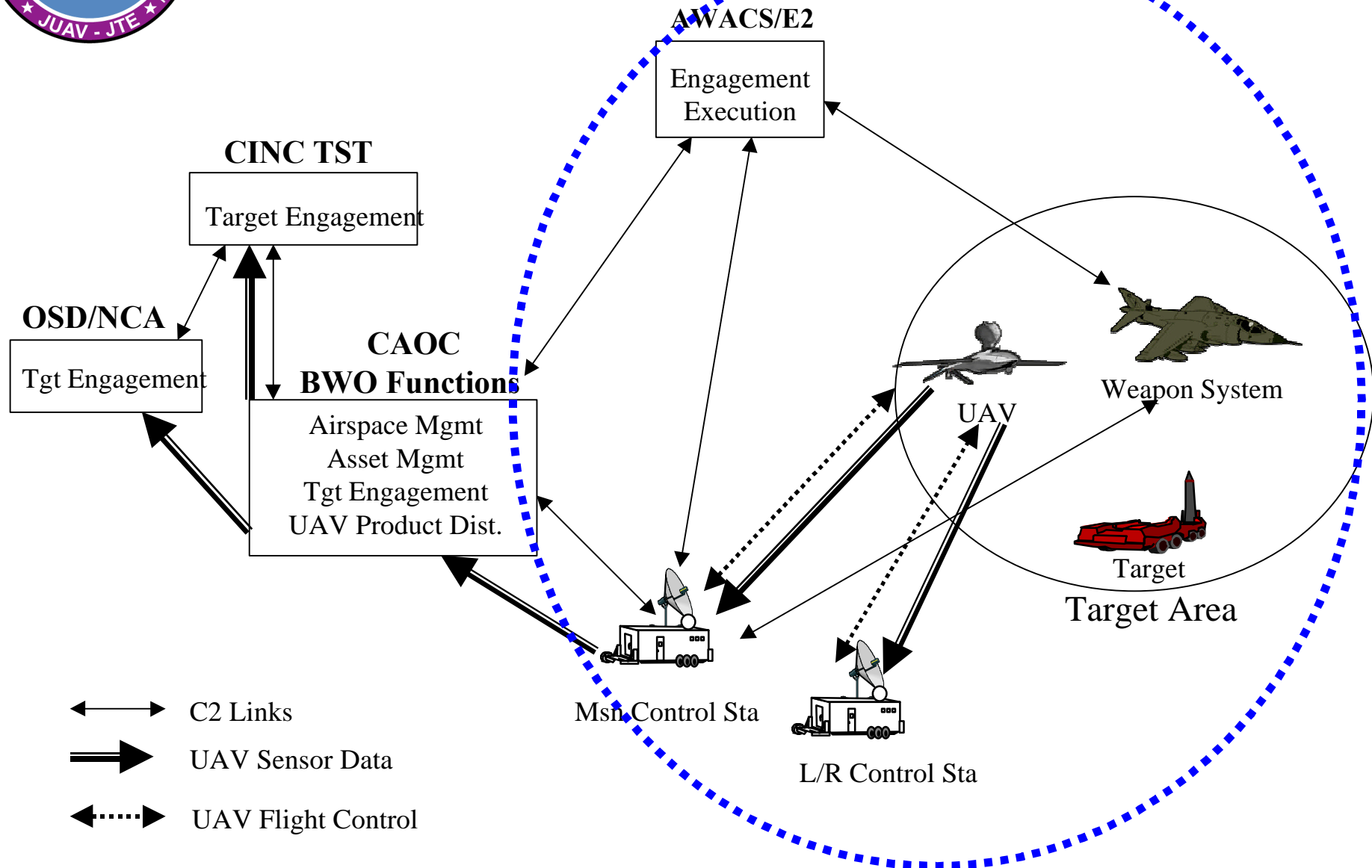



# Theater Numbers

(as of 1 June)

---

- **1200+ UAV sorties**
- **12 UAVs in theater (2 losses)**
- **700+ targets destroyed with UAV in a tactical role**
  - **Hellfire**
  - **Laser for TacAir**
  - **TacAir "Talk-Ons"**



# JUAV Products/Customers

	Selected Applicable Joint Publications	Doctrine Authorities	Trainers
	<p><b>2-01.1: Intel Support to</b></p> <p><b>2-01.3: JTTP for Joint Intel Preparation of the Battlefield</b></p> <p><b>3-07.5: JTTP for NEO</b></p> <p><b>3-09.1: JTTP for Laser Design Ops</b></p> <p><b>3-09.3: JTTP for CAS</b></p> <p><b>3-50.21: JTTP for CSAR</b></p> <p><b>3-56.1: Joint Air Operations</b></p>		<p><b>Army Warfighting</b></p> <p><b>-1</b></p> <p><b>USAF Red Flag</b></p> <p><b>USAFSOS</b></p>



# Summary

---

- **UAVs in a tactical role are here to stay**
- **By Fall 2002 USAF Predators will be Laser Design and Hellfire equipped**
- **Shadow IOC is early 2003 (4 Systems)**
- **Interim Deliverables by 31 Dec 2002 (Sim Results)**
- **JUAV-JTE as a Joint TTP clearinghouse**
- **Must do better with UAV before we get to UCAV**
  
- **Contact Info: CAPT D.A. Roy Rogers**  
**rogers.roy@fallon.navy.mil**  
**775-426-4653**