

# REPORT DOCUMENTATION PAGE

*Form Approved*  
OMB No. 0704-0188

Public reporting burden for this collection of information is estimated to average 1 hour per response, including the time for reviewing instructions, searching data sources, gathering and maintaining the data needed, and completing and reviewing the collection of information. Send comments regarding this burden estimate or any other aspect of this collection of information, including suggestions for reducing this burden to Washington Headquarters Service, Directorate for Information Operations and Reports, 1215 Jefferson Davis Highway, Suite 1204, Arlington, VA 22202-4302, and to the Office of Management and Budget, Paperwork Reduction Project (0704-0188) Washington, DC 20503.

**PLEASE DO NOT RETURN YOUR FORM TO THE ABOVE ADDRESS.**

<b>1. REPORT DATE (DD-MM-YYYY)</b> 08-20-2004			<b>2. REPORT TYPE</b> Final Report			<b>3. DATES COVERED (From - To)</b> 10/01/02-09/30/04		
<b>4. TITLE AND SUBTITLE</b>  Protein-Semiconductor Integrated Photoreceivers					<b>5a. CONTRACT NUMBER</b>			
					<b>5b. GRANT NUMBER</b> N00014-03-1-0064			
					<b>5c. PROGRAM ELEMENT NUMBER</b>			
<b>6. AUTHOR(S)</b>  Pallab Bhattacharya					<b>5d. PROJECT NUMBER</b>			
					<b>5e. TASK NUMBER</b>			
					<b>5f. WORK UNIT NUMBER</b>			
<b>7. PERFORMING ORGANIZATION NAME(S) AND ADDRESS(ES)</b> Solid State Electrical Laboratory Department of Electrical Engineering and Computer Science University of Michigan, Ann Arbor, MI 48109-2122						<b>8. PERFORMING ORGANIZATION REPORT NUMBER</b>		
<b>9. SPONSORING/MONITORING AGENCY NAME(S) AND ADDRESS(ES)</b> Office of Naval Research 800 North Quincy Street Arlington, VA 22217-5660						<b>10. SPONSOR/MONITOR'S ACRONYM(S)</b>		
						<b>11. SPONSORING/MONITORING AGENCY REPORT NUMBER</b>		
<b>12. DISTRIBUTION AVAILABILITY STATEMENT</b> Approved for public release; distribution unlimited								
<b>13. SUPPLEMENTARY NOTES</b> The views, opinions and/or findings contained in the report are those of the author(s) and should not be construed as an official Department of the Army position, policy or decision, unless so designated by other documentation.								
<b>14. ABSTRACT</b>  Bacteriorhodopsin (bR) is a light harvesting protein in the purple membrane of microorganism called Hallobacterium Salunarum. Its high internal resistance and very small current have limited the possible applications with semiconductors. One possible solution is to apply bR with field effect transistors (FETs) for FETs' high input resistance. We have demonstrated monolithically integrated bR-semiconductor transimpedance amplifier polarization sensitive photoreceivers and phototransceivers with light emitting lasers of the 655nm peak wavelength. The transient nature of the bio-transceiver output is observed to be similar to that of intrinsic bR photoelectric resoponse.								
<b>15. SUBJECT TERMS</b>								
<b>16. SECURITY CLASSIFICATION OF:</b>			<b>17. LIMITATION OF ABSTRACT</b>	<b>18. NUMBER OF PAGES</b>	<b>19a. NAME OF RESPONSIBLE PERSON</b>			
<b>a. REPORT</b>	<b>b. ABSTRACT</b>	<b>c. THIS PAGE</b>			<b>19b. TELEPHONE NUMBER (Include area code)</b>			
Unclassified	Unclassified	Unclassified	UL	9				

## Final Report

1. **Title of the Project:** "Protein-Semiconductor Integrated Photoreceiver"

2. **Grant Number:** N00014-03-1-0064

3. **Period Covered by Report:** 10/01/02-09/30/04

4. **Name of Institution:** University of Michigan

5. **Principal Investigator:** Pallab Bhattacharya

6. **Scientific Progress and Accomplishments:**

### **Bacteriorhodopsin-Semiconductor Phototransceivers**

#### • **Introduction**

The objective of this research program was to integrate ultra-light sensitive and polarization sensitive proteins and organic materials *monolithically* with inorganic semiconductor based circuits for these highly demanding applications. Bacteriorhodopsin (bR) is a light-driven protein-chromophore complex in the cell membrane of the archae *Halobacterium salinarum*. The protein occurs naturally in the cell membrane in an ordered two-dimensional crystal array, usually referred to as the purple membrane (PM) sheet. The absorption of visible light generates a photovoltage across the membrane with the large quantum efficiency (0.65). The high photosensitivity can also be made polarization sensitive.

The first opto-electronic integrated circuit (OEIC) to be investigated was a *bacteriorhodopsin* (bR) based transimpedance amplifier polarization sensitive photoreceiver. Monolithically integrated photoreceivers consisting of the three-stage transimpedance amplifier, capacitor, thin film resistor and BR/FET photodetector were designed and fabricated. The second OEIC, demonstrated for the first time, was a monolithically integrated bacteriorhodopsin-semiconductor phototransceiver. In this novel biophotonic optical interconnect, the input photoexcitation is detected by selectively deposited bR on the gate of a GaAs-based field-effect transistor. The photovoltage developed across bR is converted by the transistor into an amplified photocurrent, which drives an integrated light emitting diode with a  $\text{Ga}_{0.37}\text{Al}_{0.63}\text{As}$  active region. The input and output wavelengths are 594nm and 655nm, respectively. The transient response of the optoelectronic circuit to modulated input light has also been studied.

#### • **Photoelectric Deposition of Oriented BR Film**

Electrophoretic deposition is a simple but effective technique that orients PM patches in applied electrical fields and deposits them onto the surface of the anode, as shown in Fig. 1. BR film prepared with this method exhibits the largest photoelectric response so far, and has been used

in the preparation of most of our samples in this study. The oriented samples have been prepared on conductive ITO (indium-tin-oxide), Au covered glass slides, or even on conductive semiconductor substrates, acting as the anode during the deposition process (Fig. 1(a)). The cathode is a Platinum disc. The suspension is in contact with both electrodes, which are at a distance of 1-3 mm. An electric field of 20-40 V/cm orients the purple membranes by their permanent electric dipole moment and deposits them on the anode by electrophoresis due to their negative charge.

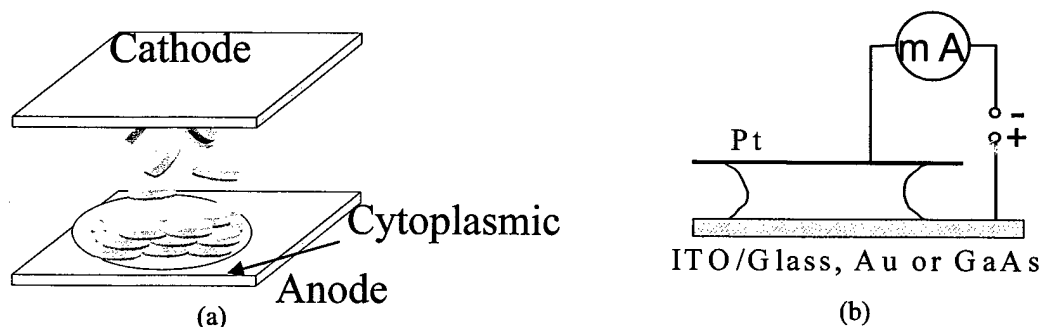

Figure 1: (a) Mechanism, and (b) set-up of the electrophoretic deposition technique.

After dehydration, a layer of  $\sim 20\text{-}50\ \mu\text{m}$  thick oriented BR film is left on the surface of the glass or semiconductor substrate. Upon light excitation, the photovoltage generated within each BR molecule will accumulate constructively, and a large photoelectric signal will, therefore, develop across the BR film. Dried BR films prepared with this method are structurally robust, and a number of laboratories have reported undiminished photoelectrical response in thin BR films for as long as two years after preparation.

The photovoltage developed across a  $50\ \mu\text{m}$ -thick oriented BR film, sandwiched between two indium tin oxide (ITO) electrodes, was measured with varying input resistance, from 16 to  $96\ \text{M}\Omega$ . A 3.5 sec. square light pulse of wavelength 594.1 nm was used for photoexcitation. The incident power was 1 mW. The BR photoresponse exhibits a differential nature with a fast rise time and a relatively slow decay time, as illustrated in Fig. 2(a). Figure 2(b) shows the measured peak-to-peak photovoltage as a function of the wavelength of the incident light. It exhibits a peak photoelectric response at 570 nm, a cut-off below 700 nm, and a residual photovoltaic response at 400 nm.

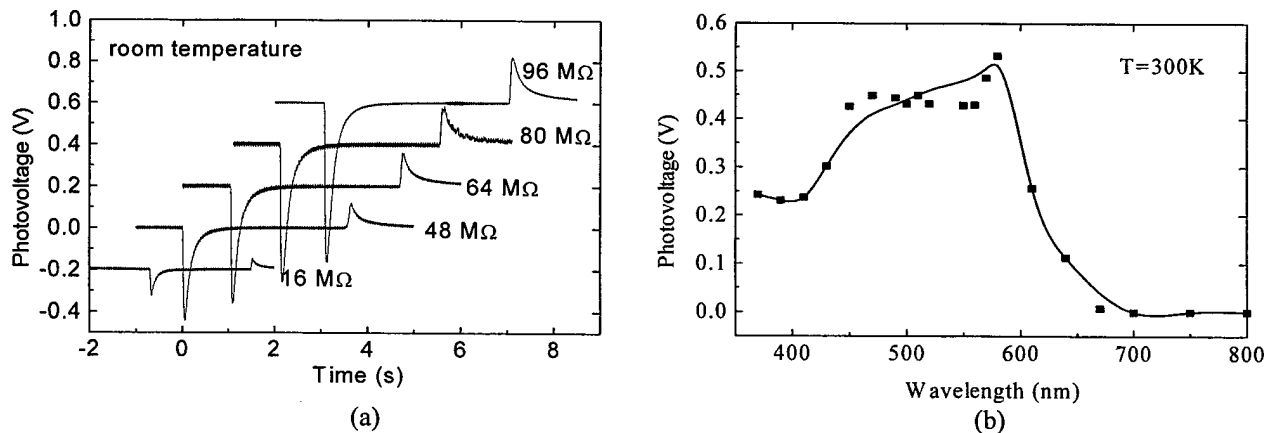

Figure 2: (a) Temporal photoelectric response and (b) action spectrum of oriented BR film.

These features are, to a large extent, consistent with the measured absorption spectrum of BR. The relatively large shoulder at  $\sim 475$  nm is probably caused by the simultaneous excitation of intermediate states by the rather long excitation pulse. The spectral nature of the electrical response indicates that the photovoltaic effect observed here originates from BR. A series of interference filters were used to provide long square light pulses ( $\sim 30$  seconds) at different wavelengths in the measurement. The photoelectric response of the BR film originates from the charge displacement within the BR molecules and their intermediates. Since each intermediate state is characterized with unique polarity and magnitude of the dipole change during the photochemical cycle, the temporal variations of the concentrations of BR intermediates in the membrane will, therefore, contribute to temporal waveform of the BR photovoltage.

• **BR-FET Monolithically Integrated Photoreceiver**

Based on our previous research experience in the design, fabrication, and characterization of BR/gallium arsenide field-effect transistor (FET) monolithically integrated photoreceivers, we have recently designed and fabricated MODFET based amplifier circuits to integrate with BR detectors for bio-phototransceiver circuits. Figure 3(a) and (b) show the circuit diagram and the integration cross section of the photoreceiver circuit, respectively. It consists of a BR/FET integrated detector unit and a three-stage transimpedance amplifier circuit with a feedback resistor.

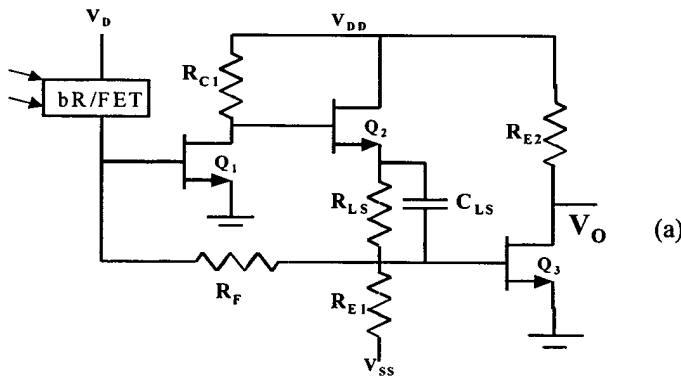
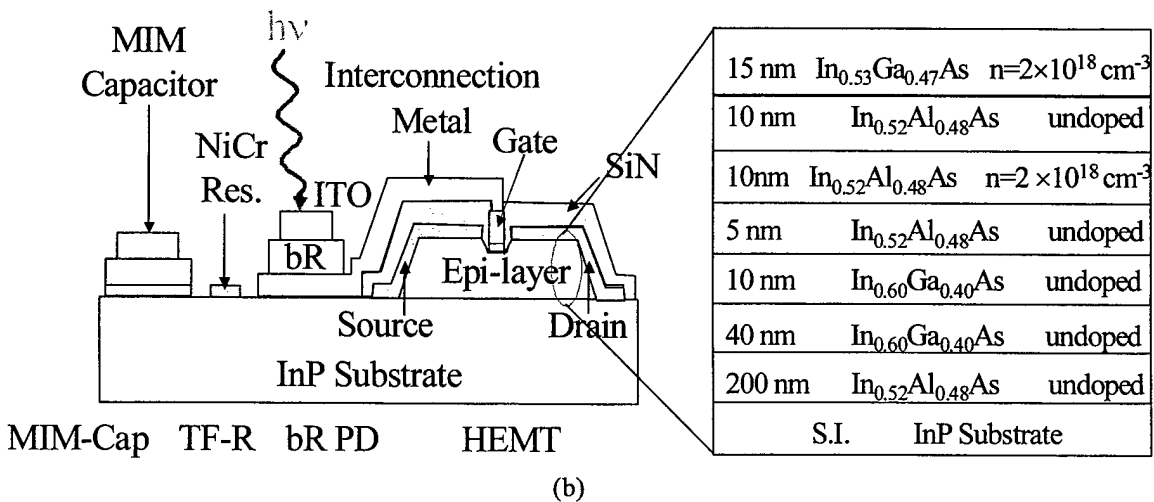

Figure 3:

(a) Schematic of a bio-photoreceiver based on hybrid integration of BR and an amplifier circuit

(b) Schematic of the integration cross section and the MODFET heterostructure



The first stage consists of the feedback amplifier which is designed to stabilize the operation points and increase the bandwidth of the circuit. The second stage is the buffer stage. It consists of a source follower serving to match the impedance between the input and output stages. The third stage has a common drain structure for further voltage amplification and output coupling. The three-stage amplifier is realized with modulation doped pseudomorphic InGaAs/InAlAs field effect transistors. The feed back resistor and bias resistors are designed to optimize the circuit performance, mainly the bandwidth, circuit gain and the noise characteristics. A capacitor is inserted at the source follower stage to enhance the amplifier bandwidth. The same pseudomorphic InGaAs/InAlAs field effect transistor structure is used to integrate with BR detector monolithically. However, a special recess etch step is applied to its fabrication to minimize the gate leakage current for higher signal coupling efficiency between BR and the embedding transistor device.

Three stage transimpedance amplifiers were designed and fabricated with InGaAs/InAlAs pseudomorphic MODFETs with 1  $\mu\text{m}$ - gate length. The amplifier S-parameters were measured in the frequency range of 0.45 to 25.5 GHz and the effective electrical transimpedance gain,  $Z_{\text{eff}}=50 |S_{21}| / |1-S_{11}|$ , was derived. The fabricated amplifiers have a -3dB bandwidth of 6 GHz and a gain of 49 dB $\Omega$  at  $V_{\text{cc}}=4$  V,  $V_{\text{ss}}=2.5$  V, as shown in Fig. 4(a). The total power dissipation of the fabricated amplifier is 250 mW at the above DC bias.

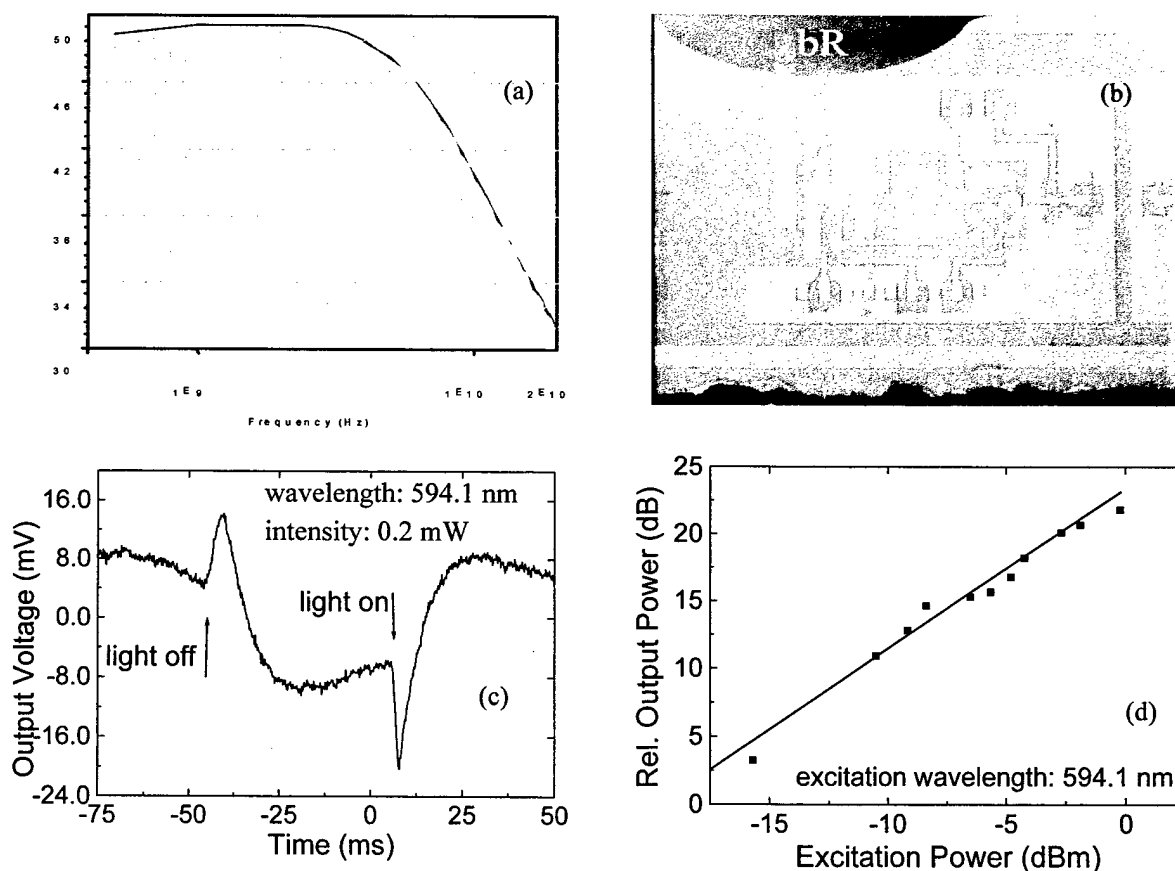

Figure 4: (a) Measured transimpedance amplifier performance; (b) micrograph of the bio-photoreceiver circuit; (c) measured bio-photoreceiver temporal response to long square light pulses. (d) linear relationship between photoreceiver output power and incident light power.

Monolithically integrated photoreceivers consisting of the three-stage transimpedance amplifier, capacitor, thin film resistor and BR/FET photodetector were designed and fabricated, as shown in Fig. 4(b). The amplifier circuit occupies a surface area of  $1.1 \times 1.8 \text{ mm}^2$ , while the BR film deposited on the chip has a circular shape with a diameter of 1 mm. Measurements on the photoreceivers were done with a Tektronix 100 MHz digital oscilloscope and with unpolarized 594.1 nm (yellow) light from a He-Ne laser incident onto an ITO electrode placed on top of the bR film. This lasing wavelength is close to 577 nm at which bR exhibits a peak in the absorption spectra. The incident light was modulated with a mechanical chopper at a frequency of 20 Hz. A variable neutral density filter is used to control the incident power, which varied from  $0.01 \text{ mW/mm}^2$  to  $1 \text{ mW/mm}^2$ . Upon excitation, the transient photovoltage developed across the bR biases the gate of the integrated MODFET, which converts it to an photocurrent. The photocurrent is subsequently amplified by the three stage transimpedance amplifier circuit and output a large voltage response. The temporal photoresponse characteristics of the photoreceiver are shown in Fig.4(c). The transient nature of the amplifier output is similar to that of the photovoltage shown in Fig.1. A photoresponsivity of  $175 \text{ V/W}$  is achieved. The photocurrent also increases linearly with incident power, as shown in Fig. 4(d). A dynamic range of 16 dB was observed in our measurement. Since our measurement is limited by the 1 mW maximum output power of the He-Ne laser, the photoreceiver is expected to have a larger dynamic range.

#### • Circuit Fabrication of bR-integrated Phototransceiver

The bR-integrated phototransceiver was fabricated using electron beam lithography and photolithography, metallization, lift-off and wet etching techniques. The heterostructure and integration schematic of phototransceiver is shown in Fig. 5(a). The process was initiated with evaporation of the top p-ohmic contact metallization ( $\text{Pd/Zn/Pd/Au} = 100/200/200/2500 \text{ \AA}$ ). The LED mesa was then formed by the wet etching in a  $\text{H}_3\text{PO}_4:\text{H}_2\text{O}_2:\text{H}_2\text{O}$  (1:1:20) solution. The undoped GaAs and AlAs layers were selectively removed with subsequent etching in  $\text{NH}_4\text{OH}:\text{H}_2\text{O}_2$  and buffered HF to expose the n-type ohmic contact layer of the MODFET. During this process, the AlAs layer was used as an etch-stop layer. The n-ohmic contact metallization ( $\text{Ni/Ge/Au/Ti/Au} = 250/325/650/200/2000 \text{ \AA}$ ) for the FET and LED was evaporated at the same time, followed by thermal annealing.

A crucial step in the processing of the OEIC is the recessing of the gate region of the transistor before the gate metal is deposited. The gate recess controls the input gate-source impedance of the transistor, which must match the large resistance of bR for successful application of the bR photovoltage onto the gate terminal. A mixture of citric acid and tripotassium citrate ( $0.5 \text{ M C}_6\text{H}_8\text{O}_7 \cdot \text{H}_2\text{O} : 0.5 \text{ M K}_3\text{C}_6\text{H}_5\text{O}_7 \cdot \text{H}_2\text{O} : \text{H}_2\text{O}_2 = 5:5:1.5$ ) was used for this purpose.<sup>8</sup> Interconnect metal ( $\text{Ti/Al/Ti/Au}$ ) with a total thickness of  $1.5 \mu\text{m}$  was deposited to electrically connect the two monolithically integrated devices. The fabrication is completed with the selective deposition of the oriented bR film. The two extended gate regions, designed as large pads, serve as the anode for immobilization of the  $1 \mu\text{m}$  thick bR film during electrophoretic deposition. The transistor gate dimension are  $2 \mu\text{m}$  (length)  $\times$   $100 \mu\text{m}$  (width). The gate metal is Ti/Au. The LED and MODFET were planarized and passivated by polyimide deposition. A photomicrograph of the completed OEIC is shown in Fig. 5.

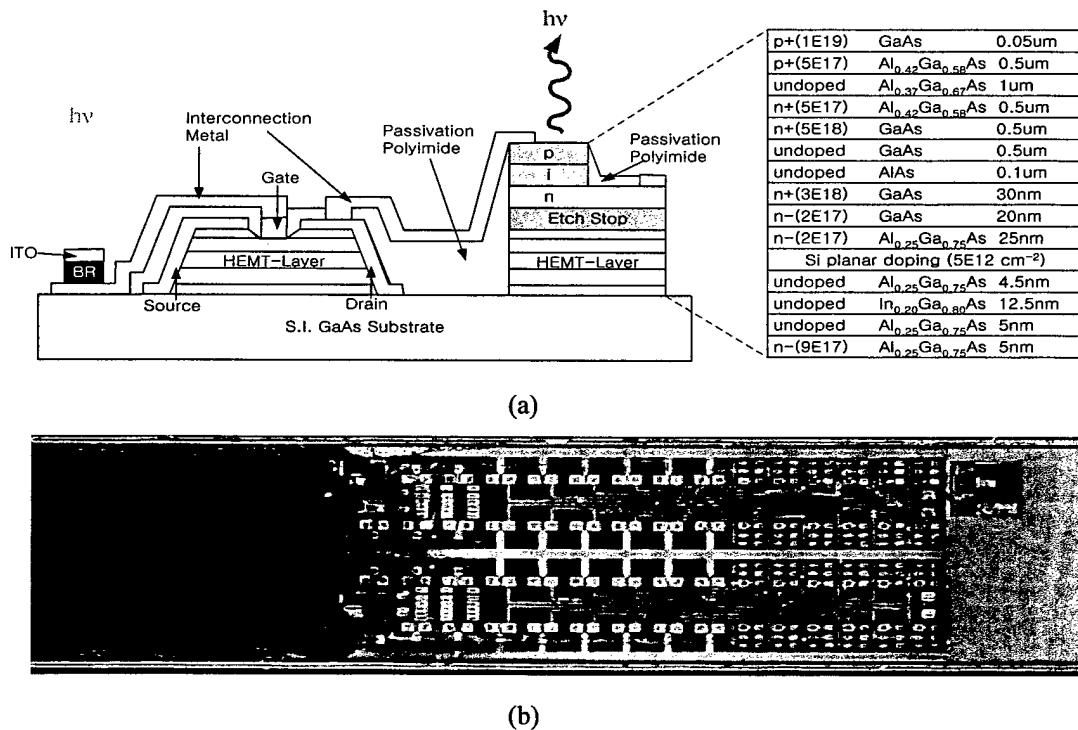

Figure 5. (a) Schematic cross-section of integrated devices with GaAs-based heterostructure with which transistors and LEDs are fabricated; (b) photomicrograph of a monolithically integrated phototransceiver showing the bR deposited on the left side of the circuit.

### • Device Characteristics and the Performance of bR-integrated Phototransceiver

In most studies, the bR film is deposited onto an indium tin oxide (ITO) glass plate, and is then put into contact with a thin, aqueous electrolyte gel to construct an electrochemical sandwich-type photocell. There are also some studies on the photoelectric response of a dried bR film sandwiched between two solid electrodes. Such structures exclude the possibility of incorporating the bR film as an active part of an integrated semiconductor circuit. However, there are some difficulties to be overcome. BR is a biomaterial with very high internal resistance and very small photocurrent on the scale of pA to nA ranges. One possible solution is to couple the bR with field effect transistors (FETs). The high input resistance of FETs will allow the photovoltage of bR to be applied to the gate of an FET and amplified to a useful photocurrent. We had succeeded in fabricating and characterizing a BR/gallium arsenide field-effect transistor (FET) monolithically integrated bio-phototransceiver in which the photovoltage developed across the bR is converted to an amplified and useful photo-induced current signal. The induced current drives the LED.

The characteristics of the individual transistors and LEDs were first measured to ascertain their suitability in the operation of the integrated phototransceiver. As mentioned earlier, the gate leakage current of the MODFET, which determines the input impedance of the device, must be extremely small (~100nA). A maximum transconductance gain  $G_{gs} = 240\text{mS/mm}$  and a pinch-off voltage of  $-1.0\text{V}$  were measured for the transistors. The electroluminescence peak output wavelength is at  $655 \pm 2\text{nm}$ . The light-current characteristics of a  $20 \times 20 \text{mm}^2$  LED are shown in

Fig. 6(a). The output power increases almost linearly with injection current. Devices of two other cross-sectional areas also exhibit identical behavior.

The characteristics of the bR-FET photoreceiver were measured. The circuit was biased for DC operation of the MODFET with  $V_{DS} = 0.7$  V. Input photoexcitation on the bR was provided with unpolarized and focused 594nm light from a He-Ne laser. Figure 6(b) depicts the measured transient and amplified photocurrent generated by the MODFET, modulated by the differential photovoltage of bR. The transient response is similar to the differential photovoltage response of bR. The maximum measured responsivity is 1.2 A/W. It should be noted that a photocurrent of the opposite polarity, to that shown in Fig. 6(b), is produced if the channel region of the MODFET is inadvertently photoexcited by scattered light. Therefore, careful alignment and small incident power are required during the measurements to eliminate or minimize undesired photoexcitation of the MODFETs.

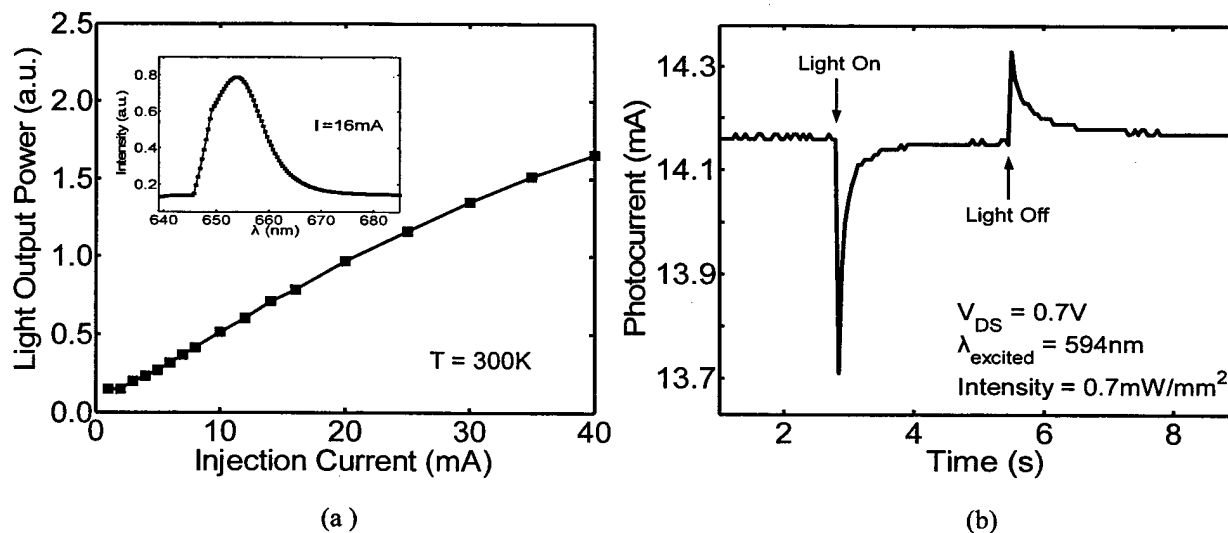

Figure 6. (a) Measured light-current characteristics of  $Al_{0.37}Ga_{0.63}As$  light emitting diode. Inset shows the output spectral characteristics; (b) temporal photocurrent response of the bR-MODFET photoreceiver to pulsed photoexcitation on the bR photodetector.

The complete phototransceiver was next characterized. In the integrated scheme, the output of bR-MODFET is directly connected to LEDs for the light modulation shown in Fig. 7(a). In order to eliminate the interference of the incident light (594nm) with the output of the LED (655nm), a 10nm bandpass filter centered at 650nm was placed at the output. Incident light pulses of 10ms and 3s duration were used for the modulation of the light output. The 10ms light pulses with a repetition rate of 1.67Hz are obtained by placing a suitable chopper in front of the He-Ne laser. Measurements were made with a Newport silicon detector and a Tektronix 200MHz digital oscilloscope. The transient modulated 655nm light output from the LED, in response to 3s incident light pulses on the bR, is depicted in Fig. 7(b). The variation of the peak output power, indicated in Fig. 7(b), with input incident power is shown in Fig. 7(c). A linear response of the phototransceiver is observed. Results from the same measurements with a 10ms duration incident light pulse are shown in Fig. 7(d). It may be noted that for longer durations of the incident light pulse, the output of the LED exactly resembles the transient response of bR. This is the first demonstration of a phototransceiver, or an optical interconnect, in which the protein bacteriorhodopsin is used as the

light detection device. Also, the fact that a monolithically integrated bR-semiconductor OEIC can be designed and fabricated opens up possibilities for more complicated integration schemes and applications.

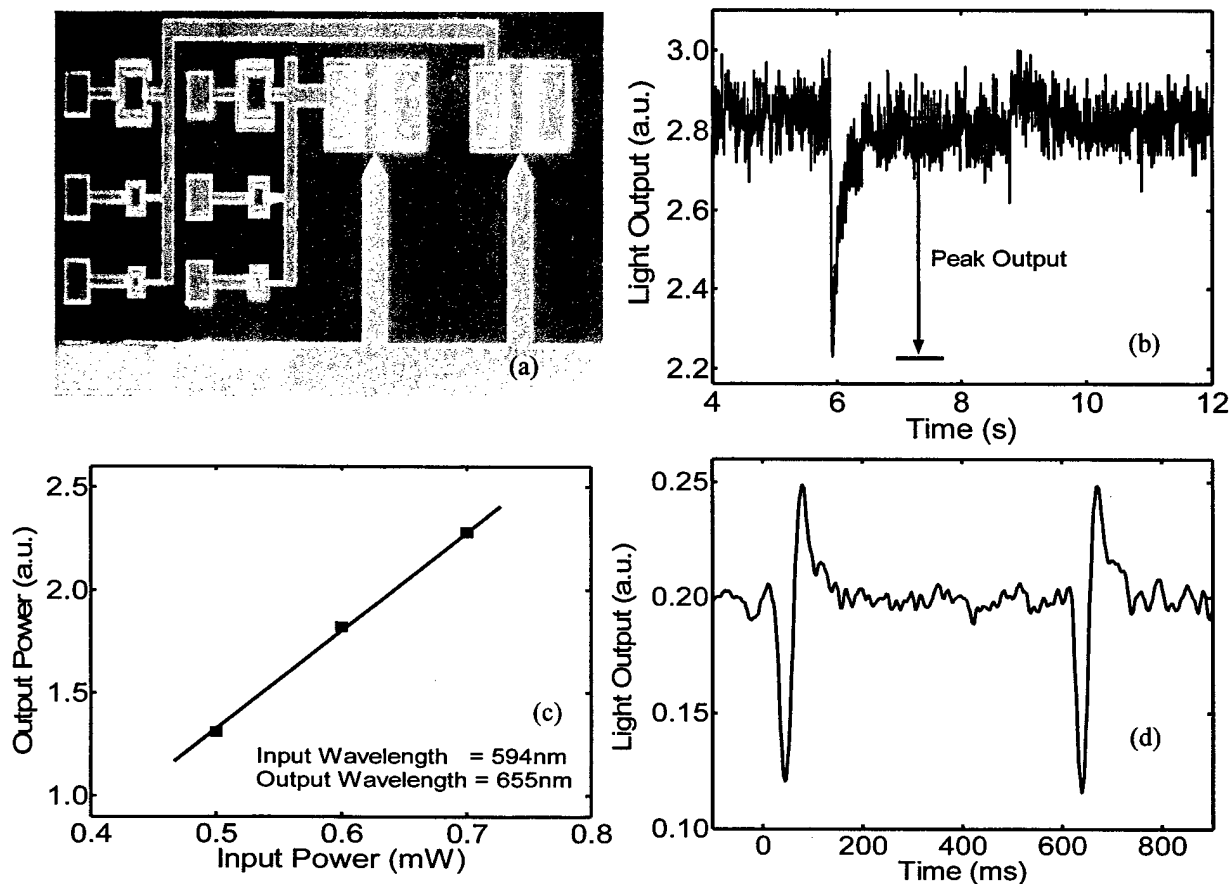

Figure 7 (a) The photomicrograph of the integrated MODFET and the LED; (b) measured temporal light output characteristics of LED with 3s optical pulses incident on bR; (c) variation of output LED light power with input photoexcitation power; (d) LED output with 10ms input light pulses.

#### 7. Technology Transfer/Initiatives:

None

#### 8. Report of Inventions:

None

#### 9. Scientific Personnel ( Honors/Awards/Degrees Received):

Graduate Student Research Assistant: J. Shin

P. Bhattacharya received the International Quantum Devices Award in 2003

#### 10. List of Manuscripts:

1. "Direct Measurement of the Photoelectric Response Time of Bacteriorhodopsin Via Electro-Optic Sampling", J. Xu, A. B. Stickrath, P. Bhattacharya et al, *Biophysics Journal*, **85**, 2003.

2. "Monolithically Integrated Bacteriorhodopsin/Semiconductor Opto-Electronic Integrated Circuit for a Bio-Photoreceiver", J. Xu, P. Bhattacharya, G. Varo, *Biosensors and Bioelectronics*, **19**, 885, 2004.
3. "Photoelectric Response of Polarization Sensitive Bacteriorhodopsin Films", Qun Li, Jeffrey A. Stuart, Robert R. Birge, Jian Xu, Andrew Stickrath, and Pallab Bhattacharya, *Biosensors and Bioelectronics* **19**, 869, 2004.
4. "A Monolithically Integrated Bacteriorhodopsin-GaAs/GaAlAs Phototransceiver" J. Shin, P. Bhattacharya, J. Xu, and G. Varo, *Optics Letters*, **29**, 2264, 2004.