

# LISA: THE LASER INTERFEROMETER SPACE ANTENNA

Masimo Tinto

Jet Propulsion Laboratory, California Institute of Technology

## Abstract

*The Laser Interferometer Space Antenna (LISA) is a deep-space mission, jointly proposed to the National Aeronautics and Space Administration (NASA), for detecting and studying gravitational radiation in the millihertz frequency band [1]. An overview of this new, exciting, and technologically challenging mission is presented, giving special emphasis to its frequency and timing requirements.*

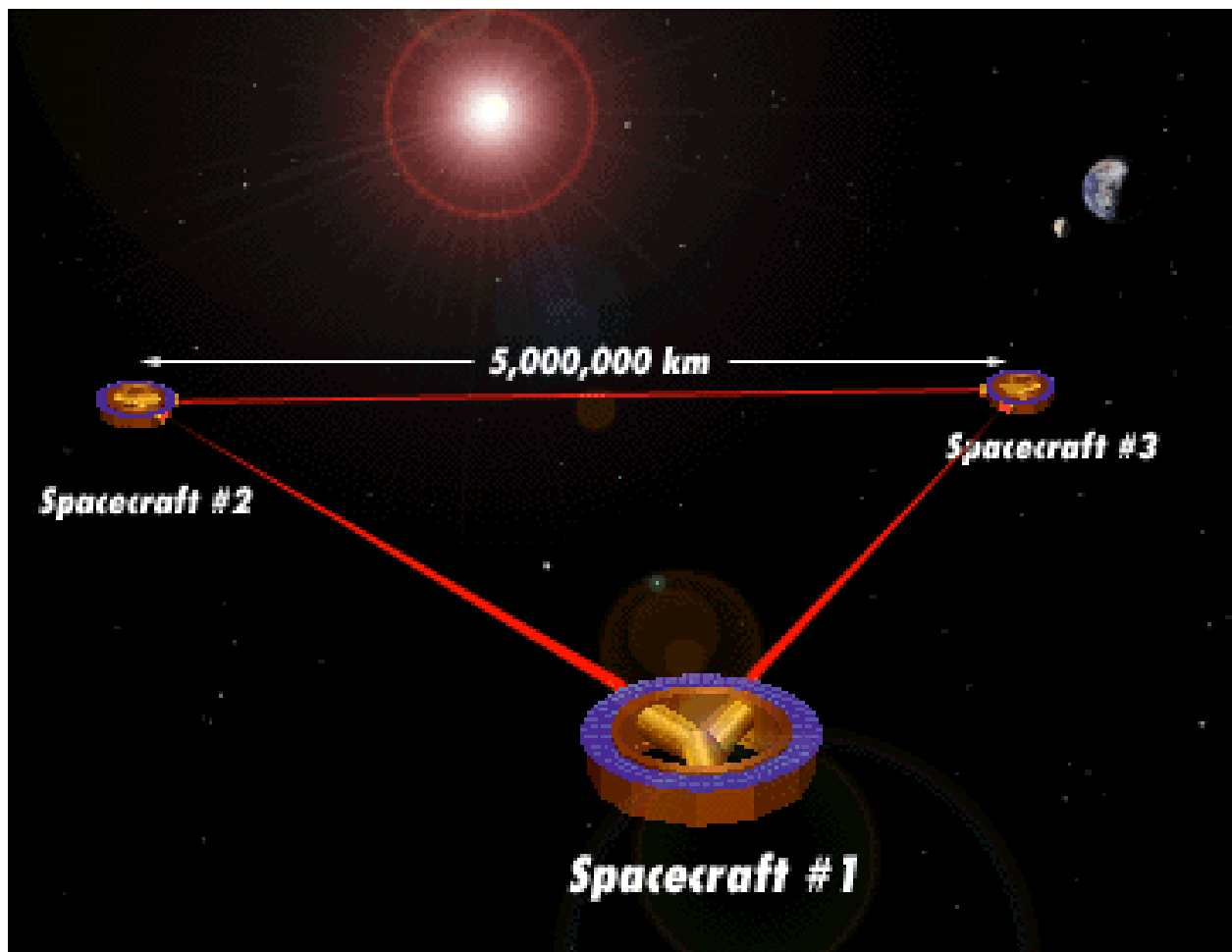

# Report Documentation Page

Form Approved  
OMB No. 0704-0188

Public reporting burden for the collection of information is estimated to average 1 hour per response, including the time for reviewing instructions, searching existing data sources, gathering and maintaining the data needed, and completing and reviewing the collection of information. Send comments regarding this burden estimate or any other aspect of this collection of information, including suggestions for reducing this burden, to Washington Headquarters Services, Directorate for Information Operations and Reports, 1215 Jefferson Davis Highway, Suite 1204, Arlington VA 22202-4302. Respondents should be aware that notwithstanding any other provision of law, no person shall be subject to a penalty for failing to comply with a collection of information if it does not display a currently valid OMB control number.

1. REPORT DATE <b>00 SEP 2004</b>		2. REPORT TYPE <b>N/A</b>		3. DATES COVERED <b>-</b>	
4. TITLE AND SUBTITLE <b>LISA: The Laser Interferometer Space Antenna</b>				5a. CONTRACT NUMBER	
				5b. GRANT NUMBER	
				5c. PROGRAM ELEMENT NUMBER	
6. AUTHOR(S)				5d. PROJECT NUMBER	
				5e. TASK NUMBER	
				5f. WORK UNIT NUMBER	
7. PERFORMING ORGANIZATION NAME(S) AND ADDRESS(ES) <b>Jet Propulsion Laboratory, California Institute of Technology</b>				8. PERFORMING ORGANIZATION REPORT NUMBER	
9. SPONSORING/MONITORING AGENCY NAME(S) AND ADDRESS(ES)				10. SPONSOR/MONITOR'S ACRONYM(S)	
				11. SPONSOR/MONITOR'S REPORT NUMBER(S)	
12. DISTRIBUTION/AVAILABILITY STATEMENT <b>Approved for public release, distribution unlimited</b>					
13. SUPPLEMENTARY NOTES <b>See also ADM001690, Proceedings of the 35th Annual Precise Time and Time Interval (PTTI) Meeting., The original document contains color images.</b>					
14. ABSTRACT					
15. SUBJECT TERMS					
16. SECURITY CLASSIFICATION OF:			17. LIMITATION OF ABSTRACT	18. NUMBER OF PAGES	19a. NAME OF RESPONSIBLE PERSON
a. REPORT <b>unclassified</b>	b. ABSTRACT <b>unclassified</b>	c. THIS PAGE <b>unclassified</b>			

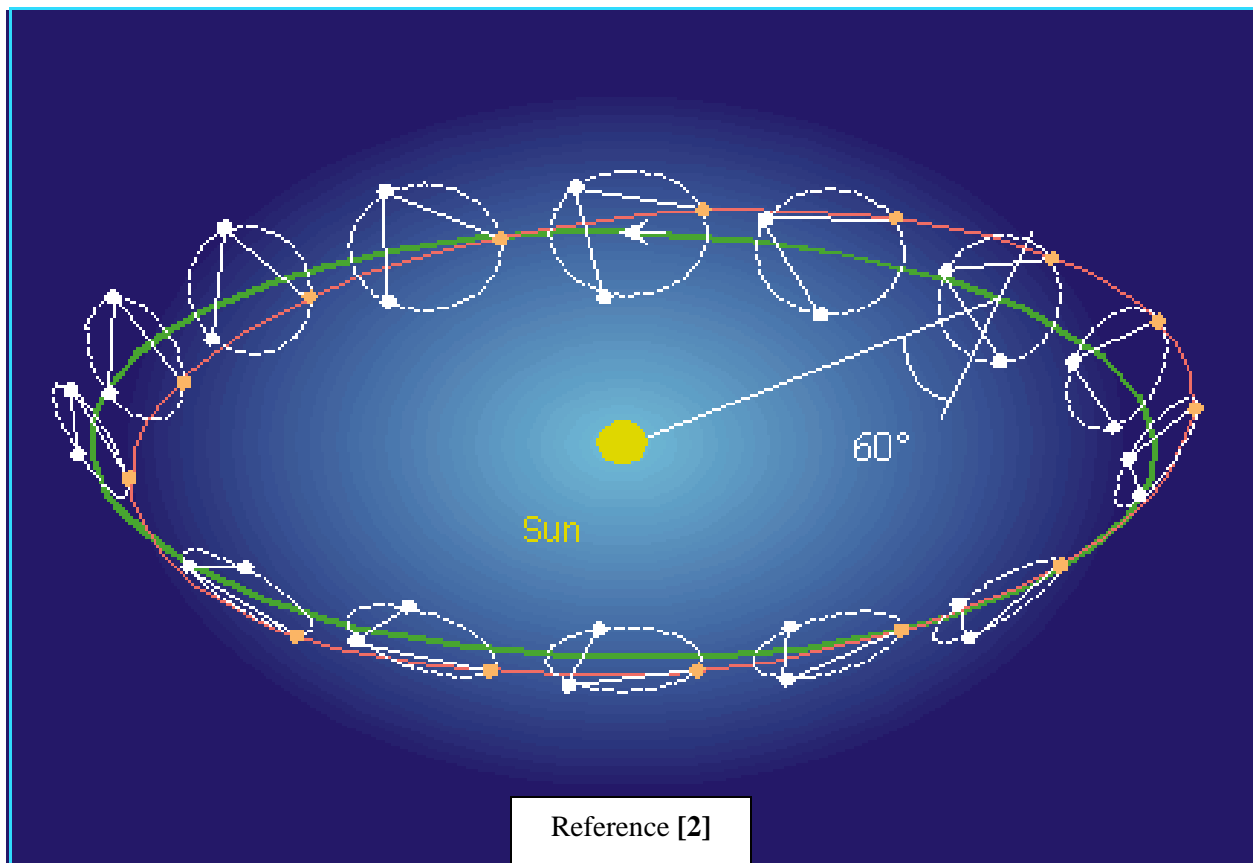
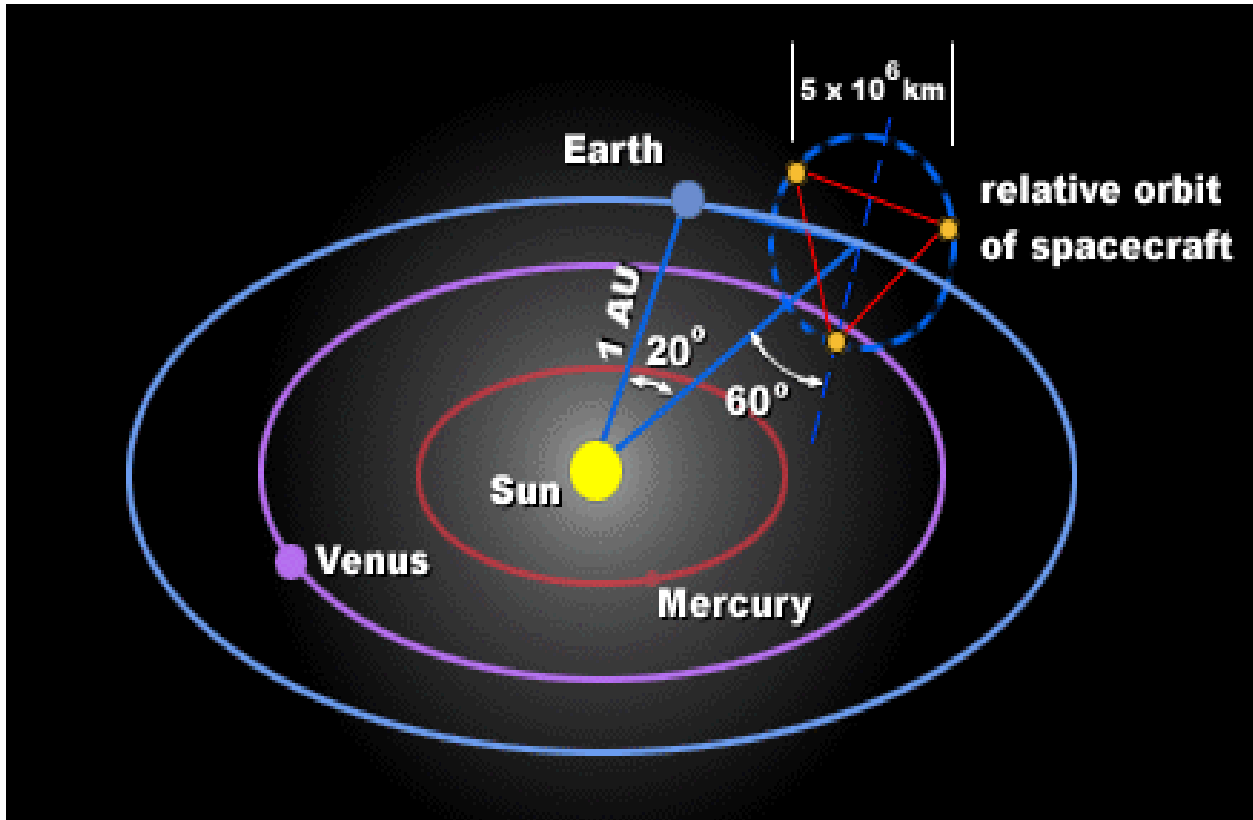

## TIME-DELAY INTERFEROMETRY

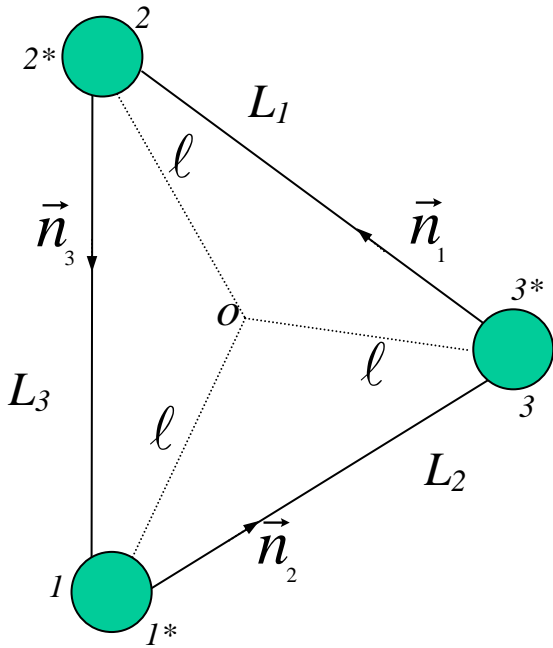

It is best to think of LISA as a closed array of six one-way delay lines between the test masses. This approach allows one to construct several interferometric data combinations. It offers advantages in hardware design, in robustness to failures of single links, and in redundancy of data [3-5].

## INTERFEROMETRIC DATA COMBINATIONS

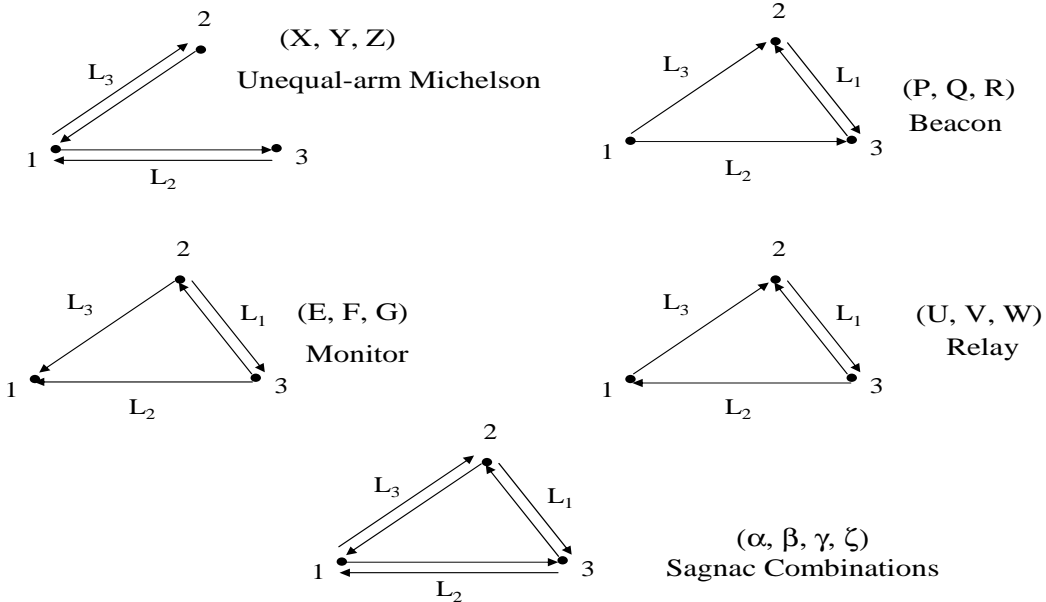

## SENSITIVITIES

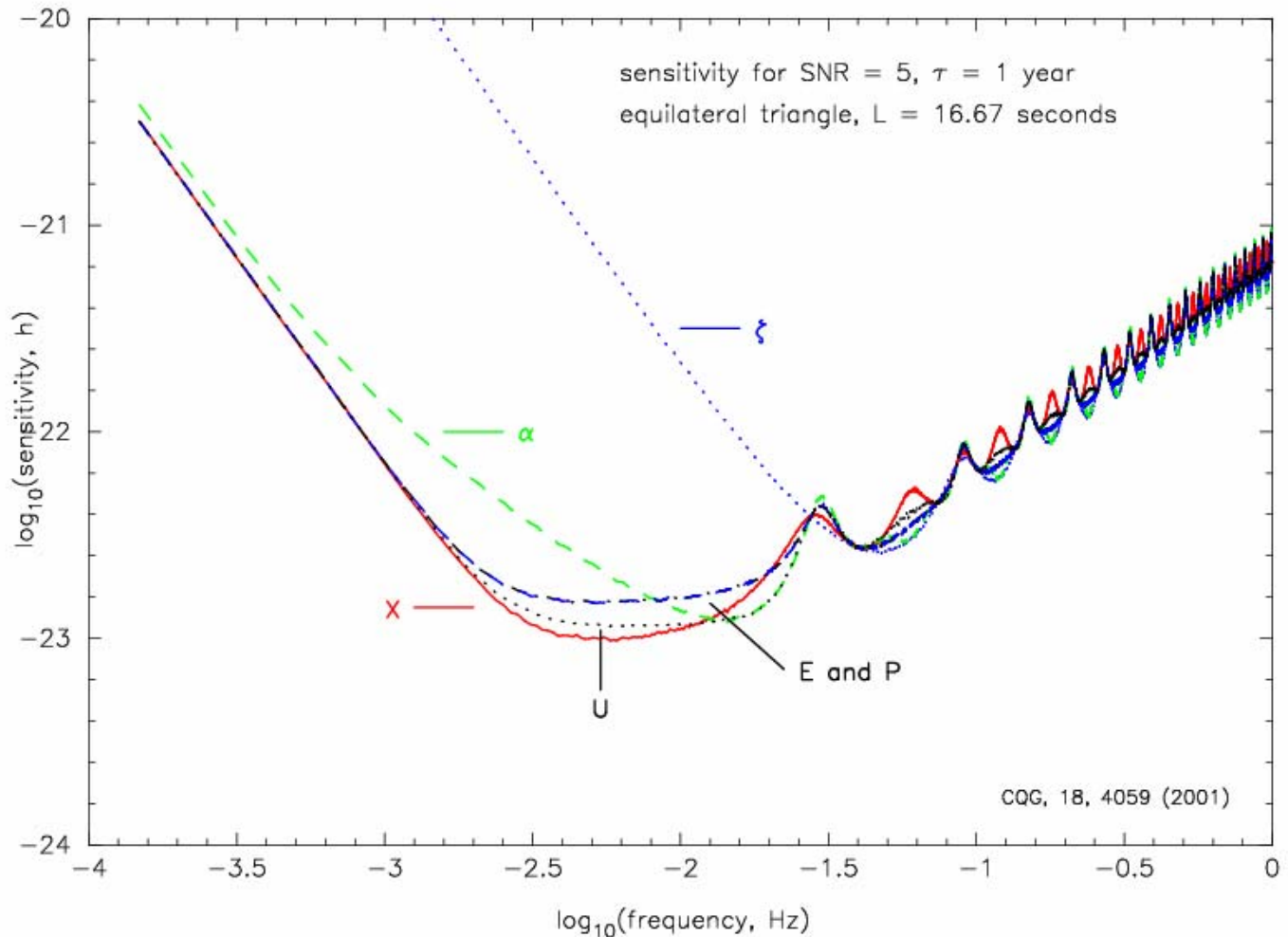

## MOVING SPACECRAFT ARRAYS AND CLOCKS SYNCHRONIZATION

The clocks onboard the LISA S/Cs ought to be synchronized to each other with an accuracy of 40 ns or better in order to suppress the lasers frequency fluctuations below the level of the remaining noise sources. In a rotating reference frame, the Sagnac effect prevents the implementation of the Einstein's Synchronization Procedure, i.e. synchronization by transmission of electromagnetic signals (GPS is a good example of this problem!) To account for the Sagnac effect, one introduces a *hypothetical* inertial reference frame, and time in this frame is the one adopted by the spacecraft clocks! In other words, the onboard receivers have to convert time information received from Earth to time in this inertial reference frame (SSB) [6-7].

In the SSB frame, the differences between back-forth delay times are very much larger than has been previously recognized. The reason is in the aberration due to motion and changes of orientation in the SSB frame. With a velocity  $V=30$  km/s, the light-transit times of light signals in opposing directions ( $L_i$  and  $L'_i$ ) will differ by as much as  $2VL$  (a few thousands km). They will also change in time due to rotation (0.1 m/s); this however is significantly smaller than the spacecraft relative velocity (10 m/s). The arm lengths need to be known with an accuracy of 100 m or better for suppressing the lasers frequency fluctuations below the level of the remaining noises [8-9].

The laser frequencies *are* different, and the spacecraft *are not* stationary. Both frequency offsets between lasers, and Doppler drifts, now bring in noise from the onboard oscillators (USO=ultra stable oscillators) used in the down-conversion of phototube fringe rates [10].

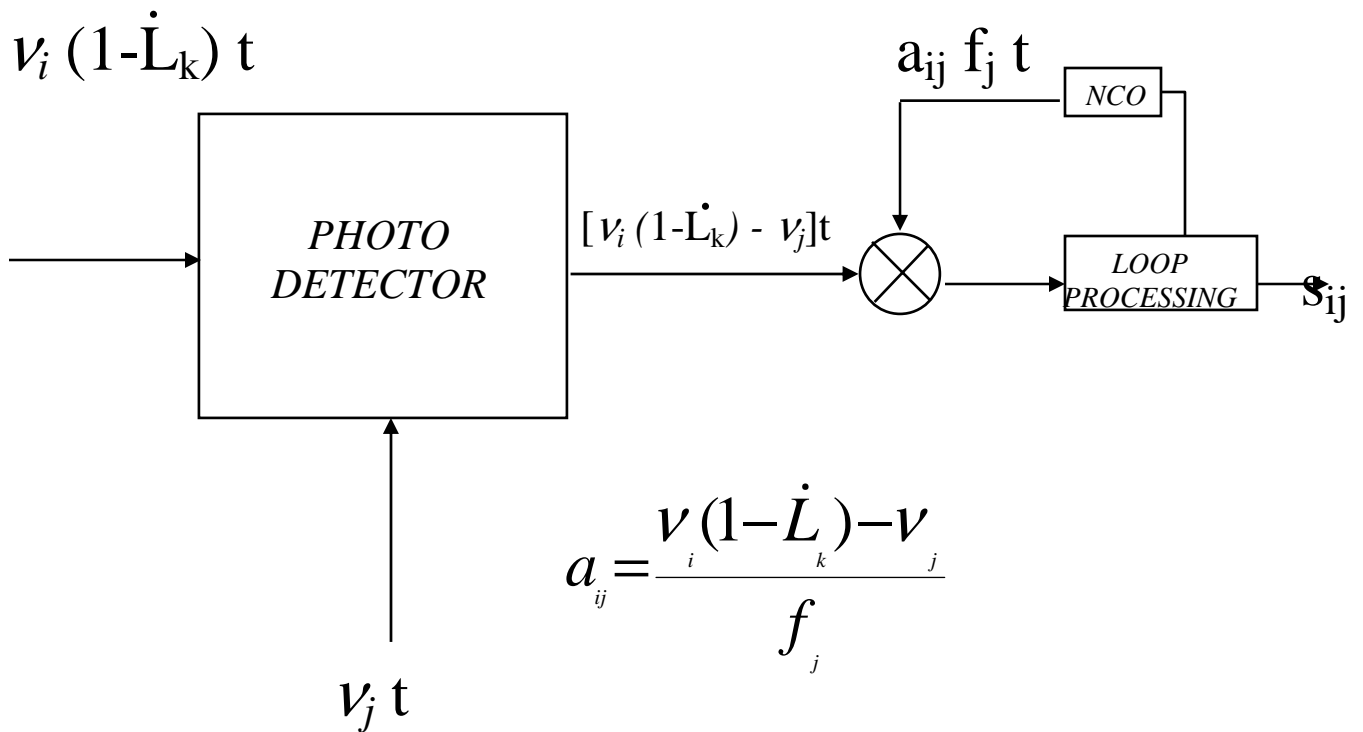

## INTERFEROMETRIC COMBINATIONS

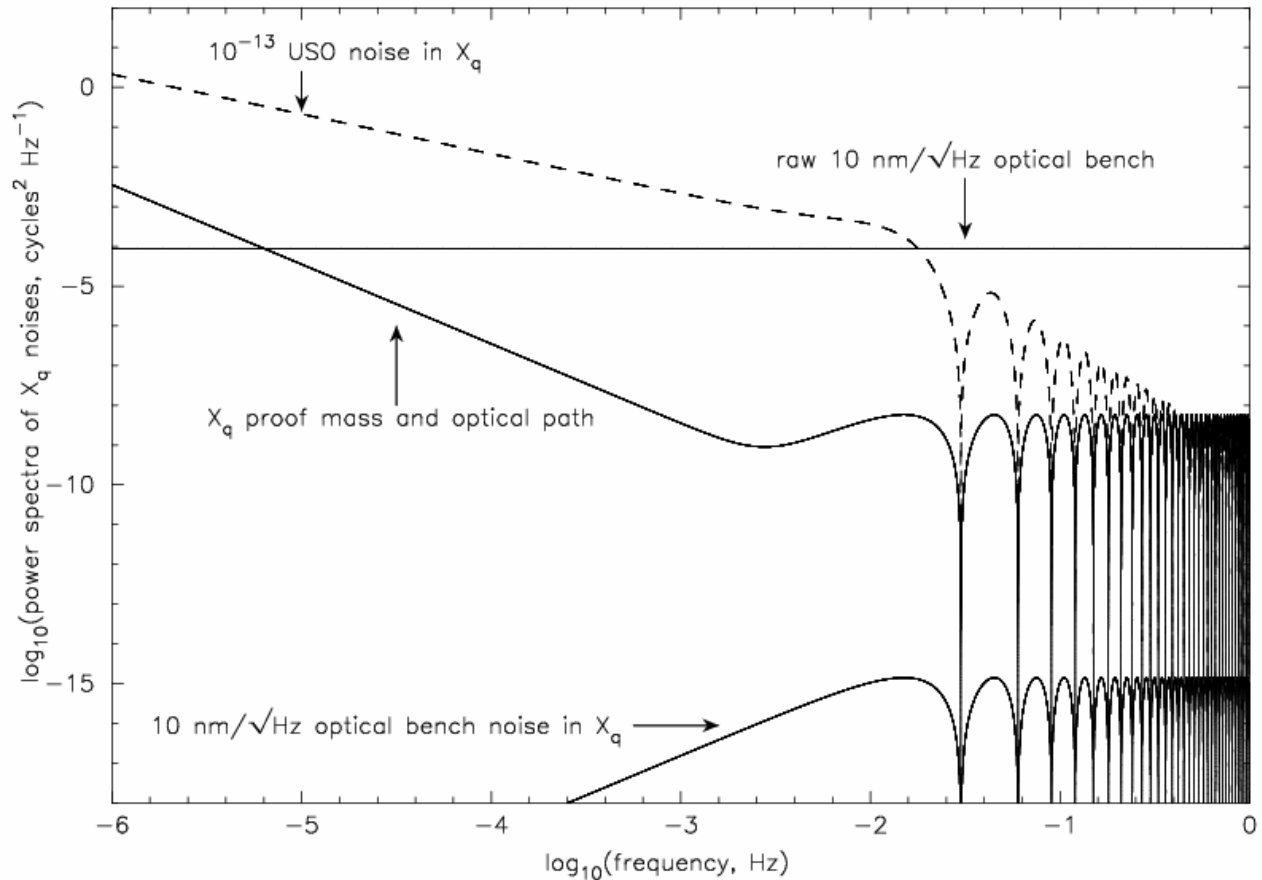

## USO NOISE CALIBRATION

In the scheme first proposed by Hellings et al. [11], in addition to the six main laser signals of frequencies  $n_i$ , a second laser signal is superimposed on each beam by either modulating it at the frequency  $f_i$  of its USO (two main side-bands), or by combining each beam with a coherent second signal at  $n_i + f_i$ .

The transmitted second signals are heterodyned against the local second signal, and independently down converted with coefficients, say  $b_{ij}$  (different from the  $a_{ij}$  introduced earlier!) to give six additional data records,  $s'_{ij}$ . By introducing the observables  $r_{ij} = (s_{ij} - s'_{ij})/f_k$ , USO phase noise can be measured and calibrated-out from the interferometric combinations.

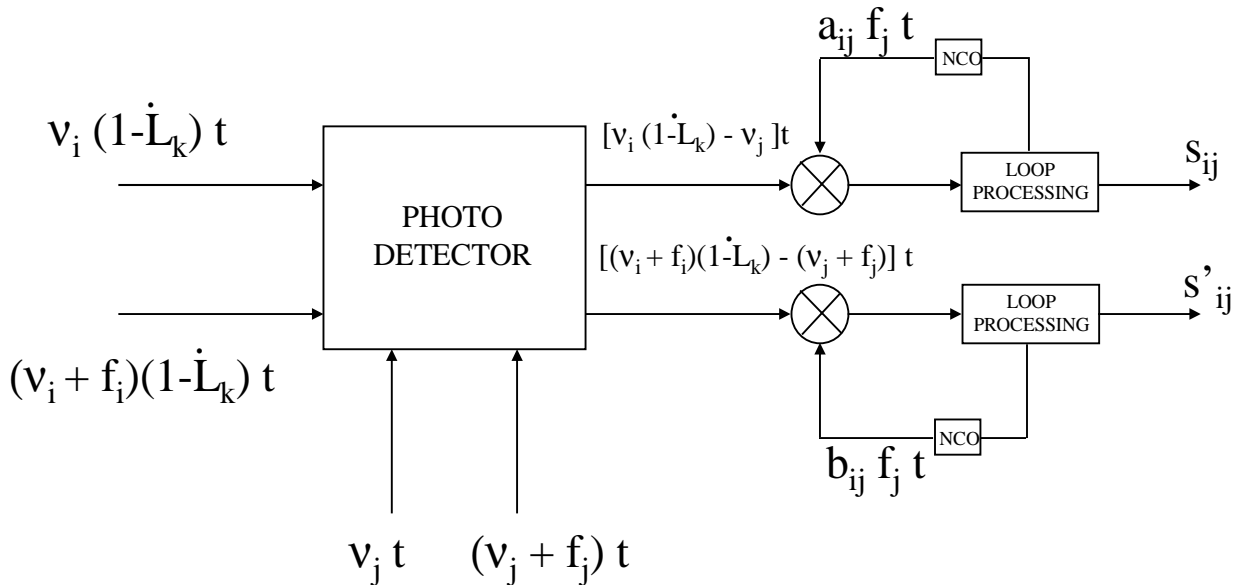

$$a_{ij} = \frac{v_i(1-\dot{L}_k) - v_j}{f_j} \quad ; \quad b_{ij} = \frac{(v_i + f_i)(1-\dot{L}_k) - (v_j + f_j)}{f_j}$$

## CONCLUSIONS

- T.D.I. provides a robust method for canceling the leading noise source – laser phase fluctuations – in an interferometer with unequal, time-variable arms.
- The onboard clocks have to be synchronized with an accuracy of 40 ns or better in order to synthesize interferometric measurements.
- The heterodyne phase measurements require an onboard USO on each spacecraft, and a highly precise and accurate Phase Meter.

## REFERENCES

- [1] P. Bender, K. Danzmann, and the LISA Study Team, 1998, “*Laser Interferometer Space Antenna for the Detection of Gravitational Waves*,” Pre-Phase A Report, MPQ233 (Max-Planck-Institut für Quantenoptik, Garching).
- [2] W. M. Folkner, F. Hechler, T. H. Sweetser, M. A. Vincent, and P. L. Bender, 1997, “LISA Orbit Selection and Stability,” **Quantum and Classical Gravity**, **14**, 1405-1410.
- [3] M. Tinto, 1996, “*Spacecraft Doppler tracking as a xylophone detector of gravitational radiation*,” **Physical Review**, **D53**, 5354-5364; 1998, **Physical Review**, **D58**, 102001.
- [4] J. W. Armstrong, F. B. Estabrook, and M. Tinto, 1999, “*Time Delay Interferometry*,” **Astrophysical Journal**, **527**, 814-826.
- [5] M. Tinto, D. A. Shaddock, J. Sylvestre, and J. W. Armstrong, 2003, “*Implementation of Time Delay Interferometry for LISA*,” **Physical Review** **D67**, 122003.
- [6] N. Asbby, “*The Sagnac effect in the GPS System*,” <http://digilander.libero.it/solciclos/>
- [7] M. Tinto, F.B. Estabrook, and J.W. Armstrong, abstract gr-qc/0310017, 6 October 2003.
- [8] D. A. Shaddock, **Physical Review D**, to appear; abstract gr-qc/0306125.
- [9] N. J. Cornish and R. W. Hellings, “*The Effects of Orbital Motion on LISA Time Delay Interferometry*,” abstract gr-qc/0306096.
- [10] M. Tinto, F.B. Estabrook, and J. W. Armstrong, 2002, “*Time-delay interferometry for LISA*,” **Physical Review** **D65**, 082003.
- [11] R. Hellings, G. Giampieri, L. Maleki, M. Tinto, K. Danzmann, J. Hough, and D. Robertson, 1996, “*Heterodyne Laser Tracking at High Doppler Rates*,” **Optics Communications**, **124**, 313-320.

## QUESTIONS AND ANSWERS

**TOM CLARK (Syntonics):** The solar system has many, many bodies in it, each one of which has some natural periodicity in its gravity signature. I would think that the one over F noise in that combined set of thousands of bodies would have quite a bit of power at these low frequencies like 200 seconds that you were describing for the gravity signature.

**MASSIMO TINTO:** You are talking in terms of as a gravitational receiver or as a perturbation to this system?

**CLARK:** Just as gravitational noise.

**TINTO:** Something that I didn't mention actually, but in our galaxy there are hundreds of millions of binary systems, white dwarf binaries, which, actually, we allow to appear incoherently to the measurements, in at least a weaker form. In balancing, in a sense, it will provide the gravitational wave confusion noise. They will sit above the sensitivity level that we estimated.

So, from one point of view, it can be regarded as a beautiful signal so you will detect it and you will see it. If you are able to discriminate it against the noise, you will have a detection. But at the same time, if you want to observe other kinds of signals, then you have to account for it and perhaps try to remove it.

