

Final Report on

**High-Order Hybrid Finite Element Technology for Simulation of  
Large-Scale Array Antennas Embedded in  
Inhomogeneous Media**

ONR Award No.: N00014-01-1-0210

*Jianming Jin, PI*  
Center for Computational Electromagnetics  
Department of Electrical and Computer Engineering  
University of Illinois at Urbana-Champaign  
Urbana, Illinois 61801-2991

November 1, 2004

**DISTRIBUTION STATEMENT A**  
Approved for Public Release  
Distribution Unlimited

20041115 035

Final Report on

**High-Order Hybrid Finite Element Technology for Simulation of  
Large-Scale Array Antennas Embedded in  
Inhomogeneous Media**

ONR Award No.: N00014-01-1-0210

*Jianming Jin, PI*  
Center for Computational Electromagnetics  
Department of Electrical and Computer Engineering  
University of Illinois at Urbana-Champaign  
Urbana, Illinois 61801-2991

November 1, 2004

REPORT DOCUMENTATION PAGE			Form Approved OMB No. 0704-0188	
<small>The public reporting burden for this collection of information is estimated to average 1 hour per response, including the time for reviewing instructions, searching existing data sources, gathering and maintaining the data needed, and completing and reviewing the collection of information. Send comments regarding this burden estimate or any other aspect of this collection of information, including suggestions for reducing the burden, to Department of Defense, Washington Headquarters Services, Directorate for Information Operations and Reports (0704-0188), 1215 Jefferson Davis Highway, Suite 1204, Arlington, VA 22202-4302. Respondents should be aware that notwithstanding any other provision of law, no person shall be subject to any penalty for failing to comply with a collection of information if it does not display a currently valid OMB control number.</small> <b>PLEASE DO NOT RETURN YOUR FORM TO THE ABOVE ADDRESS.</b>				
1. REPORT DATE (DD-MM-YYYY) 30/09/04		2. REPORT TYPE Final Report		3. DATES COVERED (From - To) 01/09/00 - 30/09/04
4. TITLE AND SUBTITLE Higher-Order Hybrid Finite Element Technology for Simulation of Large-Scale Array Antennas Embedded in Inhomogeneous Media			5a. CONTRACT NUMBER N00014-01-1-0210	
			5b. GRANT NUMBER	
			5c. PROGRAM ELEMENT NUMBER	
			5d. PROJECT NUMBER	
			5e. TASK NUMBER	
			5f. WORK UNIT NUMBER	
6. AUTHOR(S)  Jianming Jin				
7. PERFORMING ORGANIZATION NAME(S) AND ADDRESS(ES) University of Illinois 1406 W. Green St. Urbana IL 61801			8. PERFORMING ORGANIZATION REPORT NUMBER	
9. SPONSORING/MONITORING AGENCY NAME(S) AND ADDRESS(ES) Office of Naval Research Ballston Centre Tower One 800 North Quincy St. Arlington VA 22217-5660			10. SPONSOR/MONITOR'S ACRONYM(S)  ONR	
			11. SPONSOR/MONITOR'S REPORT NUMBER(S)	
12. DISTRIBUTION/AVAILABILITY STATEMENT Distribution unlimited.				
<b>DISTRIBUTION STATEMENT A</b> Approved for Public Release Distribution Unlimited				
13. SUPPLEMENTARY NOTES				
14. ABSTRACT This report summarizes our research effort on the development of higher-order hybrid finite element techniques that are capable of simulating large array antennas embedded in inhomogeneous media. The effort led to the development of a suite of FEM-based simulation tools to deal with a variety of array antennas, which include (i) infinitely large periodic phased arrays, (ii) array antennas that are finite in one dimension and infinitely periodic in the other dimension, (iii) finite array antennas with arbitrary array elements, and (iv) conformal array antennas mounted on a large complex platform. The simulation techniques have the following important characteristics: (i) higher-order geometrical modeling, (ii) higher-order field discretization, (iii) hybridization with surface integral equations using fast algorithms, (iv) a highly effective preconditioner, and (v) accurate antenna feed modeling.				
15. SUBJECT TERMS Finite element method, conformal array antennas, antenna feed modeling, hybrid techniques, fast algorithms, higher-order methods.				
16. SECURITY CLASSIFICATION OF:			17. LIMITATION OF ABSTRACT  UU	18. NUMBER OF PAGES 22
a. REPORT U	b. ABSTRACT U	c. THIS PAGE U		
			19a. NAME OF RESPONSIBLE PERSON Jianming Jin	
			19b. TELEPHONE NUMBER (Include area code) 217-244-0756	

Final Report on

# High-Order Hybrid Finite Element Technology for Simulation of Large-Scale Array Antennas Embedded in Inhomogeneous Media

ONR Award No.: N00014-01-1-0210

*Jianming Jin, PI*

Center for Computational Electromagnetics  
Department of Electrical and Computer Engineering  
University of Illinois at Urbana-Champaign  
Urbana, Illinois 61801-2991

## I. Introduction

The objective of this work is to develop a high-order hybrid finite element technique that is capable of simulating large array antennas embedded in inhomogeneous media. Modern air and land combat vehicles and warships are usually equipped with array antennas for a variety of communication, detection, tracking, and surveillance purposes. To reduce the radar signature and any adverse effect on the aerodynamic design, the antennas are often conformal to the surface of the platform and sometimes embedded in layered dielectric media. Placing these antennas on a platform inevitably introduces distortion in their radiation patterns and causes mutual coupling. The distortion in the radiation patterns may reduce the desired coverage for effective communications and compromise the accuracy for isolating and locating targets. The existence of mutual coupling, caused by space waves, surface waves, and scattering by the platform, reduces the electromagnetic isolation between the array elements and consequently makes it difficult to operate the array antennas simultaneously. Therefore, it is important to develop accurate numerical prediction tools to characterize the radiation patterns and mutual coupling of array antennas mounted on a complex, often large, platform. As a first step, it is necessary to develop efficient tools that can be used to simulate and optimize the design of conformal array antennas, and this is the objective of the proposed research.

## II. Performed Research

Because of its capability of modeling complex structures and inhomogeneous materials, the finite element method (FEM) is best suited to simulating complex array antennas embedded in dielectric media. During the past four years and under the support of this project, we have developed a suite of simulation tools based on the FEM to deal with a variety of array antennas. These include (i) infinitely large periodic phased arrays, (ii) array antennas that are finite in one dimension and infinitely periodic in the other dimension, (iii) finite array antennas with arbitrary array elements,

and (iv) conformal array antennas mounted on a complex, often large, platform. These are described in more details below.

**A. Infinitely large periodic phased arrays.** The analysis of large finite array antennas is usually very time-consuming and costly. Fortunately, the characteristics of an array element in a large array are similar to that in an infinite array. Hence, our first step was to develop a numerical technique that could analyze infinitely large periodic phased arrays embedded in a dielectric medium. In this case, the Floquet theorem is employed to reduce the domain of analysis to a single unit cell. Periodic boundary and radiation conditions are enforced on the surface of a single unit cell. The asymptotic waveform evaluation (AWE) technique is combined with the FEM to perform fast frequency and angular sweeps. The computed antenna parameters are compared with previously published results and good agreement is obtained. One example concerns with a circular patch array fed with coaxial lines. The periodic lengths are given by  $T_x = 34$  mm and  $T_y = 36.1$  mm, and the patch radius is  $a = 14.29$  mm. The outer and inner radii of the coaxial line used in the simulation are 1.492 and 0.456 mm, respectively. The  $S_{11}$  parameter at the coaxial port is shown in Figure 1. Both the magnitude and phase of the calculated  $S_{11}$  parameter agree with the results obtained by the hybrid generalized scattering matrix (GSM) and the FEM.

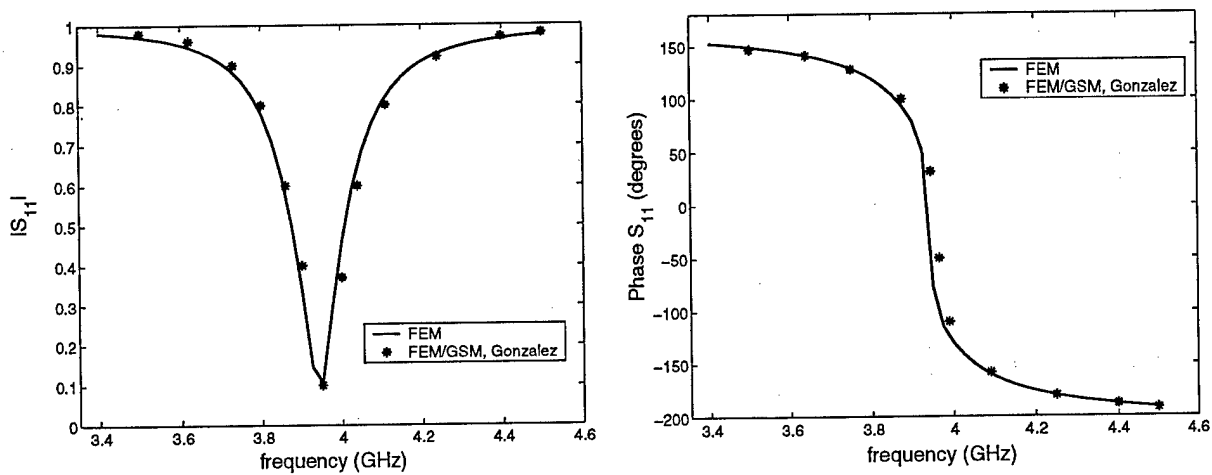

Figure 1: Magnitude and phase of the  $S_{11}$  parameter for the microstrip patch array consisting of circular patches with radius  $a = 14.29$  mm, substrate thickness  $h = 0.79$  mm, and relative permittivity of 2.33. The feed is modeled using a precise coaxial line model.

**B. Finite-by-infinite array antennas.** In this case, the array is infinite and periodic in one dimension and finite and arbitrary in the other dimension. The analysis of this type of array is important because it enables fast and efficient investigation of the truncation (or edge) effect of a finite array, which distinguishes a finite array from an infinite array. Here, the Floquet theorem is employed to reduce the domain of analysis to one row of array elements. Again, periodic boundary and radiation conditions are formulated for a unique FEM solution of the fields inside the domain of analysis. As an example, consider a 5 x infinite vivaldi array antenna. Figure 2 shows the unit cell geometry of the antenna and the normalized radiation power pattern in the E-plane as a function of the receiving angle at 3, 4, and 5 GHz.

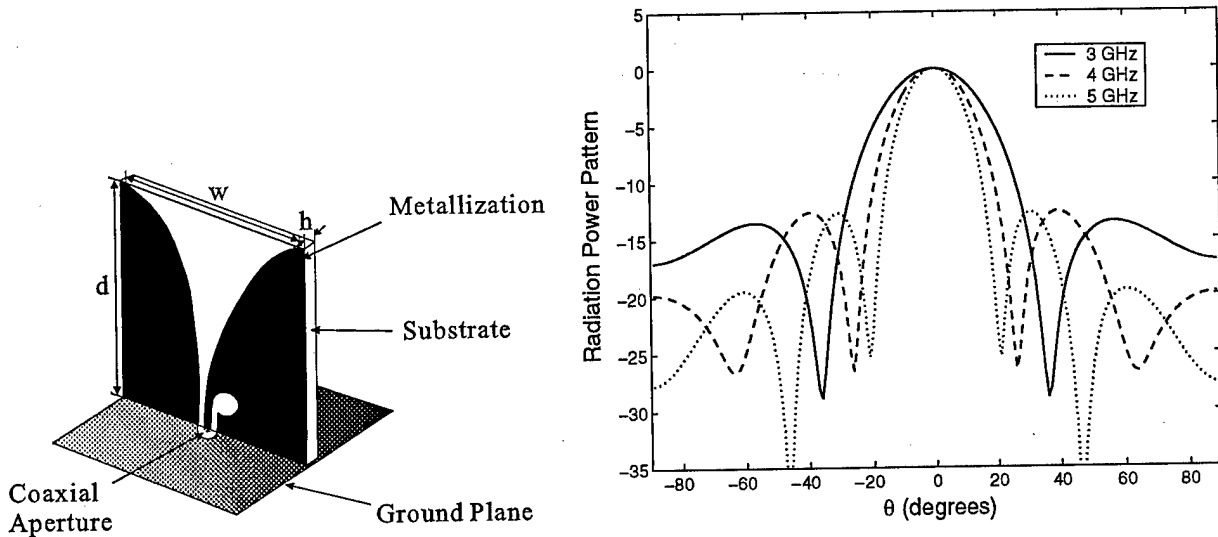

Figure 2: Geometry of the vivaldi array antenna (a single element) and the E-plane radiation pattern of the 5 x infinite vivaldi array antenna.

**C. Arbitrary finite array antennas.** Among the three types of arrays considered here, this is most challenging because even for an array antenna of moderate size, the computational requirements become very excessive. This is particularly true when the computational domain is truncated using a boundary integral equation, which yields a fully populated submatrix for the fields over the entire aperture of a finite array. To alleviate this problem, the adaptive integral method (AIM) is employed to efficiently evaluate the boundary integrals with the aid of the fast Fourier transform (FFT). Figure 3 shows the calculation of the mutual coupling (S-parameters) among a 2 x 2 microstrip patch array antenna. More specifically, it gives the plots of the 4 x 4 scattering matrix from 1 to 3 GHz. The FEM results obtained with the boundary integral truncation (circles) compared very well with the results (lines) of another calculation by the time-domain FEM using perfectly matched layers for mesh truncation.

**D. Conformal antennas mounted on a large, complex platform.** All the antennas are eventually mounted on a platform such as air and sea-going vehicles. The interaction between the antennas and platform is a critical factor in the antenna design; unfortunately, it also represents one of the most challenging problems faced by the computational electromagnetics community. In this project, we have developed a hybrid technique that couples the finite element method and a surface integral equation for evaluating conformal antennas on a large, complex platform. High-order curvilinear elements were employed to accurately represent the electric and magnetic fields as well as the antenna geometry. The high computational complexity associated with the solution of the surface integral equation was alleviated by the use of the multilevel fast multipole algorithm (MLFMA). A physical-based preconditioner was designed to drastically decrease the number of iterations required for convergence. Figure 4 shows a conformal microstrip patch antenna housed in a cavity that resides on a platform consisting of a conducting circular cylinder and a conducting plate (wing). Also shown are the measured data by Mission Research Corporation, and it is seen that the numerical results agree well with the measurement for both co- and cross-polarizations. Using the physical-based preconditioner, the final solution was obtained with only 10 iterations.

This example clearly demonstrates the significant effect of the platform on the antenna's radiation patterns.

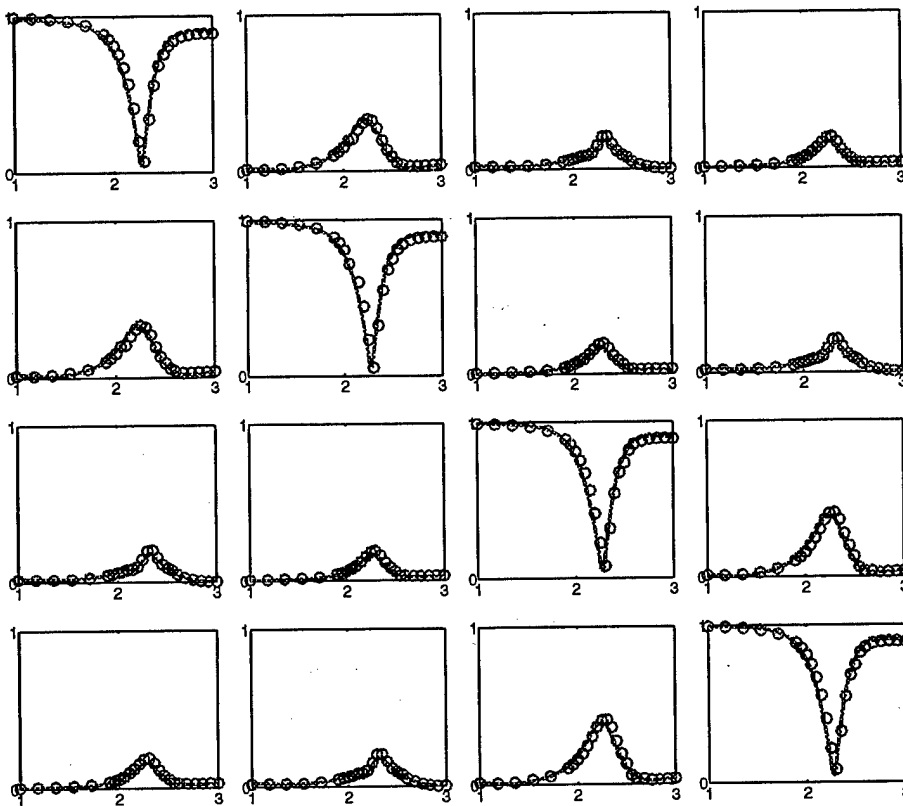

Figure 3: Scattering matrix  $S(f)$  of the  $2 \times 2$  microstrip patch array antenna. The graph on the  $i$ -th row and  $j$ -th column shows  $|S_{ij}(f)|$  for the frequency band from  $f = 1$  to  $3$  GHz.

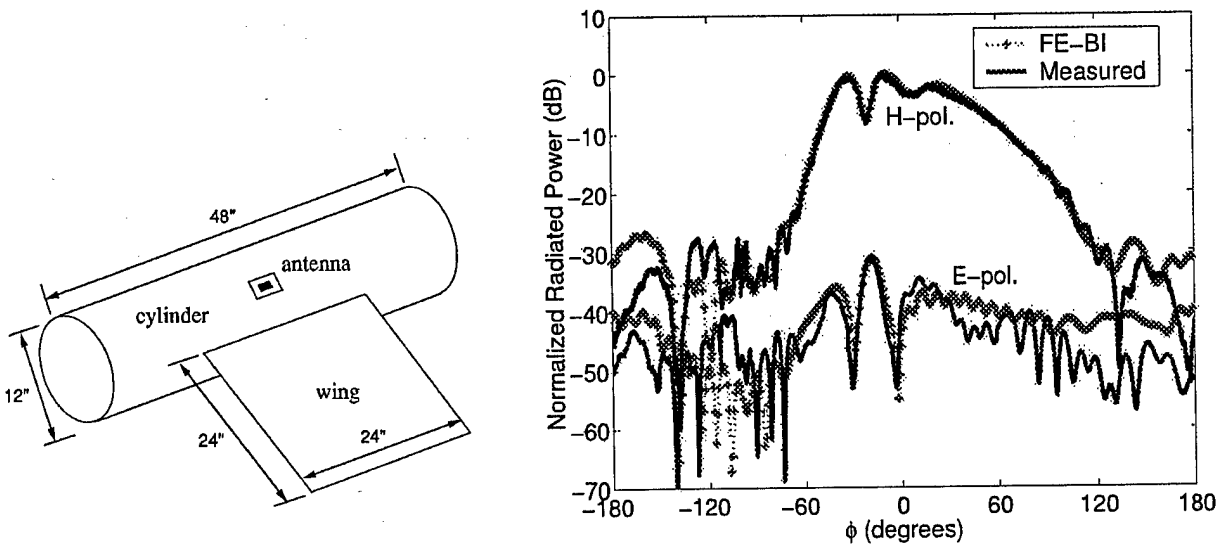

Figure 4: (a) Cavity-backed patch antenna mounted on a cylinder with a wing. (b) H-plane radiation pattern at 3.3 GHz. The simulation is performed using the higher-order, hybrid FEM/MLFMA method.

The numerical techniques developed in this project all have the following important characteristics: (i) higher-order geometrical modeling, (ii) higher-order field discretization, (iii) hybridization with surface integral equations using fast algorithms, (iv) a highly effective preconditioner, and (v) accurate antenna feed modeling. These are described in more details below.

**E. Higher-order geometrical modeling.** Higher-order geometrical modeling is important in order to model curved surfaces accurately so that surface waves can be simulated with a high accuracy. Fortunately, higher-order geometrical modeling can be achieved rather easily using parametric mapping, which can transform a planar triangular patch into a quadratic or cubic curved triangle. The same holds for tetrahedral elements. This allows the field expansion and discretization to be carried out on a regular planar triangular patch or inside a regular tetrahedron in the transformed space.

**F. Higher-order field discretization.** Higher-order field discretization is critical for achieving a higher-order convergence; or in other words, to obtain a highly accurate solution with a minimum number of unknowns, which translates to a better efficiency. Higher-order field discretization is particularly important for simulating wave phenomena because it can greatly suppress the accumulative grid dispersion error. In this work, we employed both higher-order interpolatory and hierarchical vector basis functions in the implementation of the FEM. We have performed a systematic convergence study, which confirmed higher-order convergence as expected. The use of hierarchical basis functions permits the future application of hp-adaptive refinement schemes that would yield optimal convergence for specified accuracy.

**G. Hybridization with surface integral equations using fast algorithm.** As is well known, the most challenging problem for the FEM to model unbounded electromagnetic problems is the mesh truncation. Although the use of absorbing boundary conditions (ABC), including perfectly matched layers (PML), is straightforward, the resulting solution becomes approximate because no ABC and PML can simulate a perfect absorbing boundary (which has no non-physical reflection). The best approach is to use surface integral equations that are exact and can be placed directly on the surface of the object to minimize the computational domain (thus the accumulative grid dispersion error). However, the use of a surface integral equation on the truncation surface results in a full submatrix, whose computation becomes very expensive. If we let  $N$  to denote the number of unknowns associated with the surface integral equation, the computational complexity of the submatrix is proportional to  $O(N^2)$ . This has long been regarded as the bottleneck of the surface integral equation. In this work, we removed this bottleneck and reduced the computational complexity to  $O(N \log N)$  by using either AIM or MLFMA, depending on the specific type of antennas to be analyzed.

**H. A highly effective preconditioner.** As mentioned earlier, the use of a surface integral equation on the truncation surface results in a full submatrix, which, when combined with the FEM matrix, yields a partly sparse and partly full system matrix. This system matrix is rather ill conditioned and a direct application of an iterative algorithm, such as those based on the Krylov subspace, converges very slowly. We have tested a few algebraic preconditioners; but the improvement was not significant enough to yield an efficient solution. For this work, we developed a novel, physical-based preconditioner, which turned out to be very highly effective.

This preconditioner is based on our discovery that the spectrum of a FEM/ABC system is very similar to that of the FEM/CFIE, where CFIE stands for the combined surface integral equation, which is the most accurate surface integral equation used for the mesh truncation. As a result, the FEM/ABC system serves as a very effective preconditioner for the FEM/CFIE matrix equation. With this, convergence is usually achieved within a few iterations. This preconditioner applies to both antenna and scattering problems, and its development is considered a major progress in the FEM analysis of unbounded electromagnetic problems.

**I. Accurate antenna feed modeling.** One of the very critical aspects in the development of any numerical methods for accurate antenna analysis is the modeling of antenna feeds. Although reasonably accurate results for radiation patterns can be obtained using simplified feed models, accurate characterization of input impedance and mutual coupling (mutual impedances or S-parameters) can only be obtained using accurate feed models. In practice, most antennas are fed by coaxial lines. However, most numerical analyses use simplified models to make the problem more tractable. For example, in the integral equation based method of moments (MoM) and differential equation based FEM, the delta voltage gap and current probe/filament are often used to excite an antenna. Although these simple models are capable of generating accurate radiation patterns and in some cases input impedances for simple wire and patch antennas, they often do not work well for complex antennas and, worst of all, their modeling errors cannot be systematically reduced (controllable). Although the use of a magnetic frill model improves the accuracy of impedance calculation for wire antennas, its practical application is still very limited. In this work, we have developed an accurate method to model a variety of antenna feeds. This model is directly based on the full-wave analysis of electric and magnetic fields in the feed structures, instead of using the voltage and current concepts. This model involves a reference surface, often chosen to be close to the coaxial or waveguide opening, and then represents the total field as the superposition of the incident and reflected waves (including higher-order modes excited by the structures in the vicinity of the feed). An exact boundary condition can then be derived, which can be incorporated into the FEM solution of the antenna problem. As a result, the input for the numerical analysis is the incident field in the feed line and the output is the reflection coefficient ( $S_{11}$ ), from which the input impedance can be readily calculated. In the case for multiple antennas, which is of particular interest in this project, a full S-parameter matrix can be computed by exciting each antenna. This model is applicable to most antenna feeds (coaxial lines, waveguides, and other transmission lines). Except for numerical discretization, the model is exact and its numerical solution is error controllable. More important, since this model calculates the reflected waves in the feed lines, one can incorporate the effect of feed structures, such as corporate feed, into the array antenna analysis. All the results shown above were obtained using this feed model.

### III. Beyond the Proposed

In addition to the work described above, which has successfully fulfilled the proposed objective, we have started to explore two topics that are closely related to the proposed project. (1) As we mentioned earlier, an efficient and accurate mesh truncation technique is critical to the FEM analysis of large-scale antenna problems. In this work, we have employed surface integral equations with fast algorithms for this purpose. Researchers in computational acoustics, however,

reported better performance of infinite elements over surface integral equations. This has also led some researchers in computational electromagnetics to pursue the development of infinite elements for the mesh truncation. We have developed infinite elements and conducted a detailed comparative study against the FEM with a surface integral equation and concluded that the second approach is more accurate and efficient than the first one using infinite elements. We also discovered that for three-dimensional electromagnetic problems, infinite elements can only be developed for a spherical surface because of the vectorial nature of the field wave equation, although for the acoustic field infinite elements have been developed for spheroidal surfaces. The use of spherical truncation surfaces is highly inefficient and has little practical use for large-scale antenna problems, whereas surface integral equations can be placed right on the surface of the antenna to be simulated. (2) Recognizing the importance and urgent need to develop computational techniques to simulate ultra-wide band antennas, we started to develop the higher-order time-domain finite element method (TDFEM). Beside its capability to perform a broadband analysis, the TDFEM can effectively model nonlinear and inhomogeneous devices/components/medium. Its geometrical modeling capability is excellent and the time-stepping can be made unconditionally stable. Hence, this method overcomes all the shortcomings of the frequency-domain and FDTD techniques. Its major drawbacks are (i) the need to solve a large sparse matrix equation in each time step and (ii) the implementation of perfectly matched layers (PML) becomes very complicated. However, the development of large, sparse matrix solvers has partially alleviated the first drawback. We have concentrated our effort to develop a stable PML formulation for the mesh truncation of the TDFEM. We are convinced that the TDFEM offers a promising approach to the simulation of ultra wide band antennas with nonlinear active devices.

#### IV. Journal Publications Resulting from This Grant:

1. J. Liu and J. M. Jin, "A novel hybridization of higher order finite element and boundary integral methods for electromagnetic scattering and radiation problems," *IEEE Trans. Antennas Propagat.*, vol. 49, no. 12, pp. 1794-1806, Dec. 2001.
2. J. Liu and J. M. Jin, "A highly effective preconditioner for solving the finite element--boundary integral matrix equation of 3-D scattering," *IEEE Trans. Antennas Propagat.*, vol. 50, no. 9, pp. 1212-1221, Sept. 2002.
3. J. Liu and J. M. Jin, "Analysis of conformal antennas on a complex platform," *Microwave Opt. Tech. Lett.*, vol. 36, no. 2, pp. 139-142, Jan. 2003.
4. Z. Lou and J. M. Jin, "High-order finite element analysis of periodic absorbers," *Microwave Opt. Tech. Lett.*, vol. 37, no. 3, pp. 203-207, May 2003.
5. Z. Lou and J. M. Jin, "Analysis of 3-D frequency selective structures using a high-order finite element method," *Microwave Opt. Tech. Lett.*, vol. 38, no. 4, pp. 259-263, Aug. 2003.
6. Z. Lou and J. M. Jin, "Finite element analysis of phased array antennas," *Microwave Opt. Tech. Lett.*, vol. 40, no. 6, pp. 490-496, March 2004.
7. Z. Lou and J. M. Jin, "Higher-order finite element analysis of finite-by-infinite arrays," *Electromagn.*, vol. 24, no. 7, 2004.
8. J. K. Byun and J. M. Jin, "A comparative study of infinite elements for two-dimensional electromagnetic scattering analysis," *Electromagn.*, vol. 24, no. 4, pp. 219-236, 2004.
9. J. K. Byun and J. M. Jin, "Finite-element analysis of scattering from a complex BOR using spherical infinite elements," *Electromagn.*, submitted for publication, June 2004.

10. M. M. Botha and J. M. Jin, "On the variational formulation of hybrid finite element-boundary integral techniques for electromagnetic analysis," *IEEE Trans. Antennas Propagat.*, accepted for publication, Dec. 2003.
11. M. M. Botha and J. M. Jin, "Adaptive finite element-boundary integral analysis for electromagnetic fields in 3D," *IEEE Trans. Antennas Propagat.*, submitted for publication, June 2004.
12. T. Rylander and J. M. Jin, "Stable coaxial waveguide port algorithm for the time domain finite element method," *Microwave Opt. Tech. Lett.*, vol. 42, no. 2, pp. 115-119, July 2004.
13. T. Rylander and J. M. Jin, "Perfectly matched layers for the time domain finite element method applied to Maxwell's equations," *J. Comput. Physics*, accepted for publication, 2004.
14. T. Rylander and J. M. Jin, "Perfectly matched layers in three dimensions for the time-domain finite element method applied to radiation problems," *IEEE Trans. Antennas Propagat.*, accepted for publication, 2004.

#### V. Conference Publications Resulting from This Grant:

1. J. Liu and J. M. Jin, "A novel hybridization of higher order finite element and boundary integral methods for electromagnetic scattering and radiation problems," IEEE Antennas and Propagation Society International Symposium, Boston, MA, July 2001.
2. J. Liu and J. M. Jin, "A novel, highly effective preconditioner for solving the finite element-boundary integral matrix equation of 3-D scattering," IEEE Antennas and Propagation Society International Symposium, Boston, MA, July 2001.
3. J. M. Jin and J. Liu, "A highly efficient higher-order hybrid finite element-boundary integral method for large-scale scattering analysis," XXVII-th General Assembly of the International Union of Radio Science, Maastricht, Netherlands, Aug. 2002.
4. J. Liu and J. M. Jin, "Analysis of conformal antennas on a complex platform," IEEE Antennas and Propagation Society International Symposium, Columbus, OH, June 2003.
5. Z. Lou and J. M. Jin, "High-order finite-element analysis of electromagnetic scattering from periodic structures," IEEE Antennas and Propagation Society International Symposium, Columbus, OH, June 2003.
6. T. Rylander and J. M. Jin, "Stable waveguide ports for the time-domain finite element method," IEEE Antennas and Propagation Society International Symposium, Columbus, OH, June 2003.
7. T. Rylander and J. M. Jin, "Conformal perfectly matched layers for the time-domain finite element method," IEEE Antennas and Propagation Society International Symposium, Columbus, OH, June 2003.
8. Z. Lou and J. M. Jin, "Higher-order finite element analysis of finite-by-infinite arrays," IEEE Antennas and Propagation Society International Symposium, Monterey, CA, June 2004.
9. J. K. Byun and J. M. Jin, "A comparative study of infinite elements for two-dimensional electromagnetic scattering analysis," IEEE Antennas and Propagation Society International Symposium, Monterey, CA, June 2004.
10. M. M. Botha and J. M. Jin, "A stationary FE-BI formulation for 3D electromagnetic analysis," IEEE Antennas and Propagation Society International Symposium, Monterey, CA, June 2004.
11. M. M. Botha and J. M. Jin, "A posteriori error indicators for 3D electromagnetic FE-BI analysis," IEEE Antennas and Propagation Society International Symposium, Monterey, CA, June 2004.

12. T. Rylander and J. M. Jin, "Perfectly matched layers in three dimensions for the time-domain finite element method," IEEE Antennas and Propagation Society International Symposium, Monterey, CA, June 2004.
13. T. Rylander and J. M. Jin, "Stability and accuracy of coaxial waveguide port algorithm for the time-domain finite element method," IEEE Antennas and Propagation Society International Symposium, Monterey, CA, June 2004.
14. Z. Lou, K. Mao, and J. M. Jin, "Finite element analysis of conformal array antennas," 2004 International Symposium on Antennas and Propagation, Sendai, Japan, Aug. 2004.

## **VI. Appendix**

Attached is a set of viewgraphs, which illustrate some of the work performed under this grant.



# Finite Element Analysis of Conformal Array Antennas

Z. Lou, K. Mao, and J.-M. Jin

Center for Computational Electromagnetics  
Department of Electrical and Computer Engineering  
University of Illinois at Urbana-Champaign  
Urbana, Illinois 61801-2991

\*This work is supported by a grant from ONR under contract number N00014-01-1-0210.

**ECE-ILLINOIS**  
Electrical and Computer Engineering  
University of Illinois at Urbana-Champaign



**ECE-ILLINOIS**  
Electrical and Computer Engineering  
University of Illinois at Urbana-Champaign

## Introduction

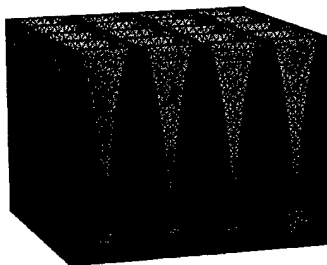

### Technical Significance:

- Fast and accurate numerical simulation is critical to the design of advanced complex array antennas embedded in dielectric media
- Characterization of the mutual coupling is required for the design of multifunction (transmitter/receiver) antenna systems

### Impact:

- Simulation of large, complex antenna systems for navy and other applications
- Advancement of knowledge in computational electromagnetics for complex geometries
- Development of new techniques and algorithms that hybridize different numerical methods
- Methodologies also applicable to scattering, wave interaction, and circuits problems

## Introduction

A complete set of FEM-based numerical simulation techniques has been developed for a systematic analysis of:

- **Infinite periodic phased arrays**
  - Single unit cell analysis for basic characteristics
- **Finite-by-infinite array antennas**
  - Study of truncation (edge) effects
- **Arbitrary finite array antennas**
  - Highly challenging for a large finite array
- **Conformal antennas mounted on a platform**
  - The ultimate goal – Antenna/platform interaction modeling

## Introduction

Common characteristics of the FEM-based numerical simulation techniques developed here:

- **Higher-order geometrical modeling**
- **Higher-order field discretization**
- **Accurate antenna feed modeling**
- **Boundary integral equations (BIE) as exact mesh truncation**
- **Fast algorithms (FMM & AIM) for BIE evaluation**
- **Effective preconditioner to accelerate convergence of iterative solution**

## Feed Modeling

- > Accurate feed modeling is critical for antenna simulation (especially for characterization of input impedance, mutual coupling, & S-parameter).
- > Feeding structure included by coaxial cables with waveguide ports (rigorous formulation).

⇒ Full-wave computation.

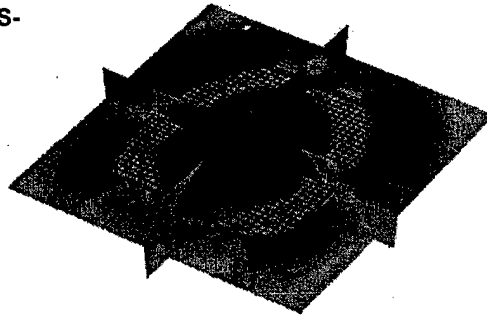
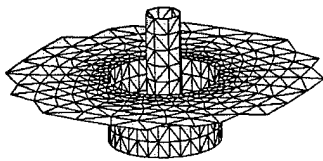

Color: snap shot of electric field magnitude around single patch antenna on a finite ground plane.

## Typical Feed Structures

⇒ Antenna element (opened for visualization of interior structures)

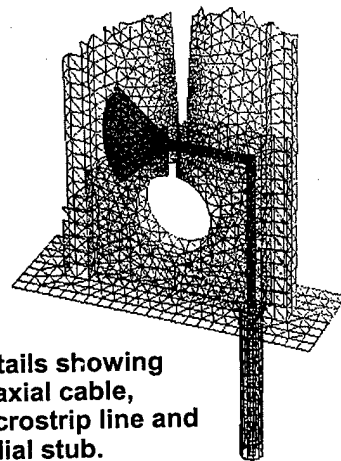
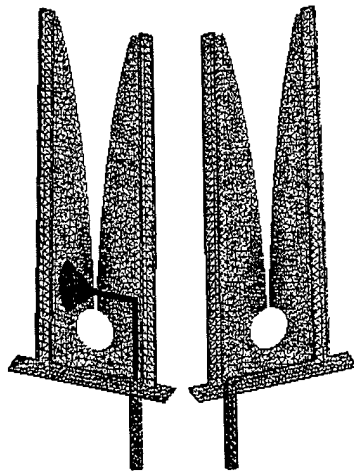

⇒ Details showing coaxial cable, microstrip line and radial stub.

1. Probe model (Simple & approximate)

2. Coaxial model (Accurate)

At the port:

$$\mathbf{E}(x, y, z) = \mathbf{E}^{\text{inc}}(x, y, z) + \sum_{m=0}^{\infty} \sum_{n=0}^{\infty} a_{mn} \mathbf{e}_{mn}(x, y) e^{\gamma_{mn} z}$$

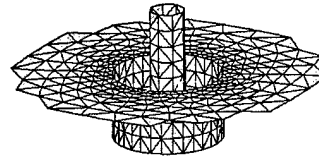

Using mode orthogonality:

$$a_{mn} = e^{-\gamma_{mn} z_1} \int_0^a \int_0^b \mathbf{e}_{mn} \cdot [\mathbf{E} - \mathbf{E}^{\text{inc}}]_{z=z_1} dx dy$$

Taking a curl:  $\hat{n} \times \nabla \times \mathbf{E} = \hat{n} \times \nabla \times \mathbf{E}^{\text{inc}} + \sum_m \sum_n a_{mn} \gamma_{mn} \mathbf{e}_{mn}(x, y) e^{\gamma_{mn} z}$

Mixed boundary condition:

$$\hat{n} \times \nabla \times \mathbf{E} + P(\mathbf{E}) = \mathbf{U}^{\text{inc}}$$

Magnitude and phase of the  $S_{11}$  parameter for a microstrip patch array consisting of circular patches with radius  $a = 14.29$  mm, substrate thickness  $h = 0.79$  mm, and relative permittivity of 2.33.

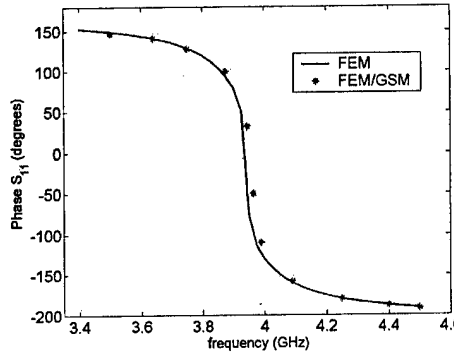
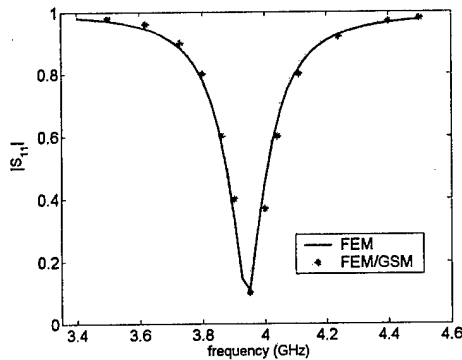

\* M. A. Gonzalez, J. A. Encinar, J. Zapata, and M. Lambea, "Full-wave analysis of cavity-scattering and probe-fed microstrip patch arrays: a hybrid mode-matching generalized scattering matrix and finite-element method," *IEEE Trans. Antennas Propagat.*, vol. 46, pp. 234-242, Feb. 1998.

### Infinite Periodic Array

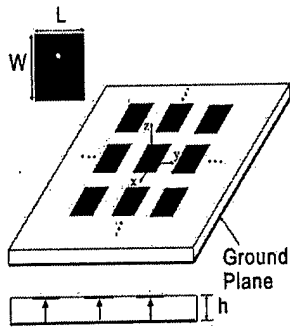

$$L = W = 0.25\lambda$$

$$T_x = T_y = 0.5\lambda$$

$$\epsilon_r = 2.5$$

### FE-BI analysis

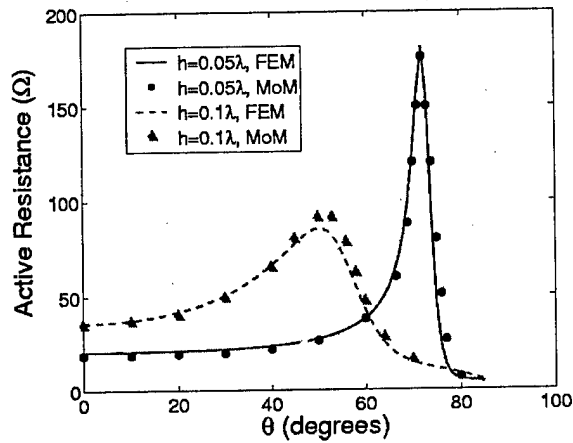

### Infinite Periodic Array

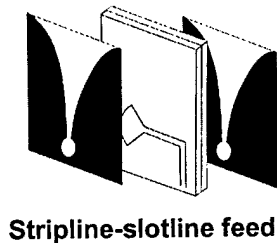
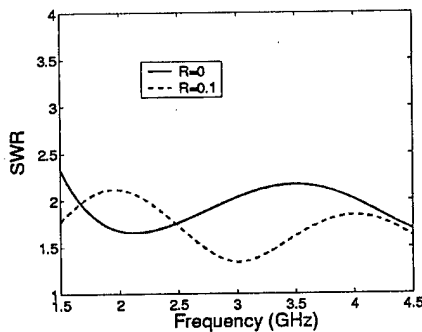

Stripline-slotline feed

### Current probe feed

R: Curvature of the flare

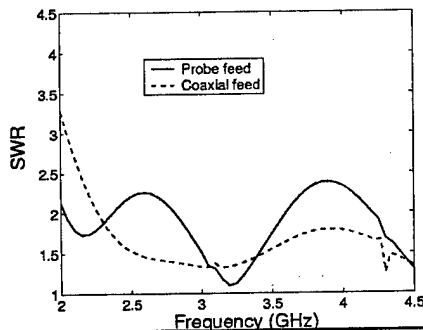
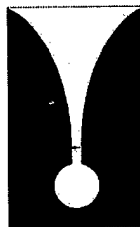

## Infinite Periodic Array

Coplanar waveguide-slotline feed:

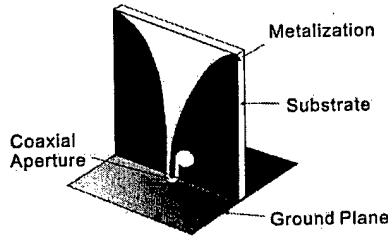

E-plane scan

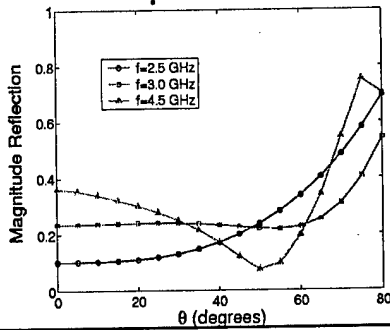

H-plane scan

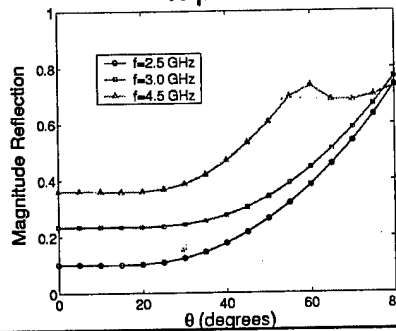

## Finite-by-Infinite Array

### Why investigate finite by infinite (FBI) arrays?

- A good model to study the effects of array truncation
- Numerically less demanding compared to finite by finite arrays
- Approximation to some realistic applications

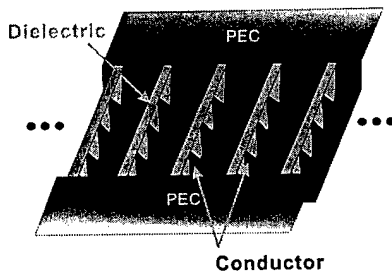

Spectral domain formulation:

$$\mathbf{H}^{scat}(r) = \frac{-jk_0 Y_0}{\pi} \sum_{p=-\infty}^{\infty} e^{-jk_x x} \int_{-\infty}^{\infty} \tilde{\mathbf{G}}(k_{xp}, k_y) \cdot \tilde{\mathbf{M}}(k_{xp}, k_y) e^{-jk_y y} dk_y$$

Mixed spectral-spatial domain formulation:

$$\mathbf{H}^{scat}(r) = -2jk_0 Y_0 \sum_{p=-\infty}^{\infty} e^{-jk_x x} \int_{\Gamma_y} \tilde{\mathbf{G}}(k_{xp}, y; y') \cdot \tilde{\mathbf{M}}(k_{xp}, y') dy'$$

## Finite-by-Infinite Array

- Frequency: 5 GHz
- Unit cell dimension: 32 X 34 X 33.3 mm
- Reflection calculated at individual coaxial ports for E-plane scan

$d = 33.3 \text{ mm}$   
 $w = 30 \text{ mm}$   
 $h = 1.27 \text{ mm}$   
 $\epsilon_r = 6.0$

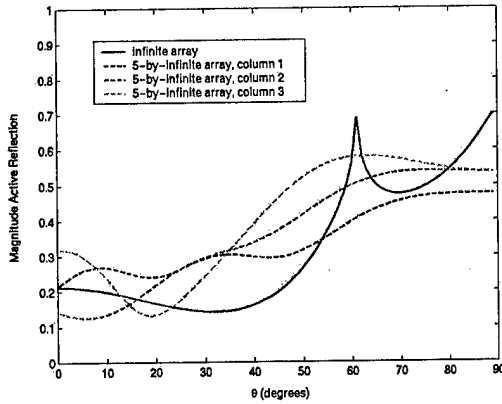
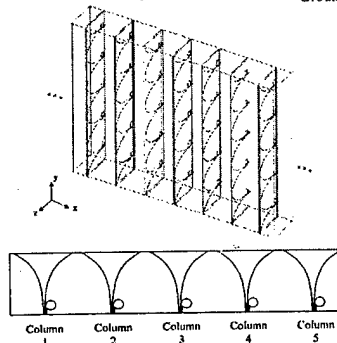
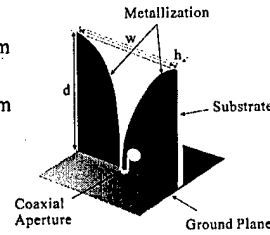

## Finite-by-Infinite Array

- Reflection calculated at individual coaxial ports for broadside radiation

$d = 33.3 \text{ mm}$   
 $w = 30 \text{ mm}$   
 $h = 1.27 \text{ mm}$   
 $\epsilon_r = 6.0$

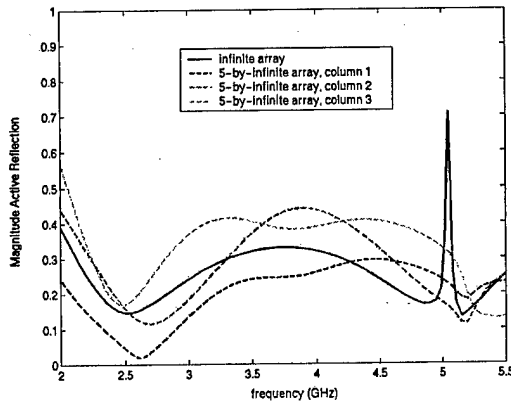
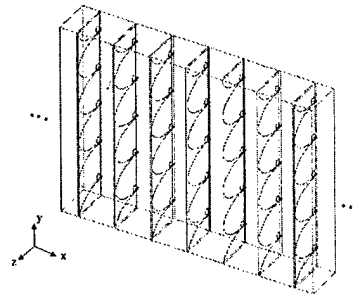
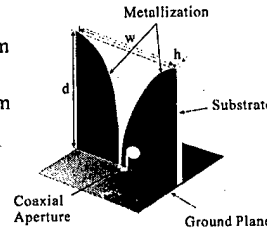

## Finite-by-Infinite Array

- Geometry of the vivaldi array antenna (a single element) and the E-plane radiation pattern of the 5 x infinite vivaldi array antenna

$d = 33.3 \text{ mm}$   
 $w = 30 \text{ mm}$   
 $h = 1.27 \text{ mm}$   
 $\epsilon_r = 6.0$

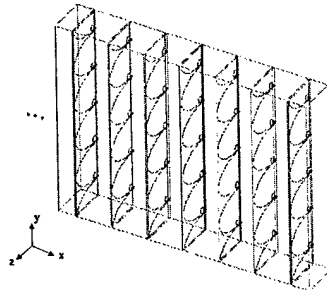
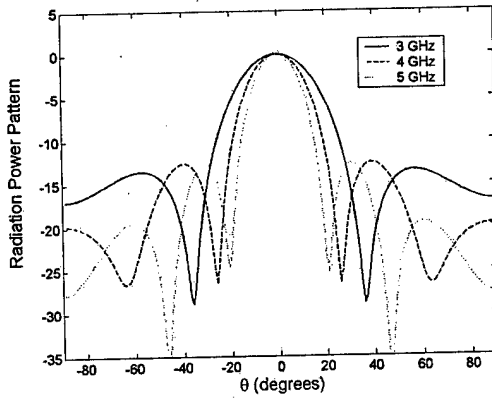
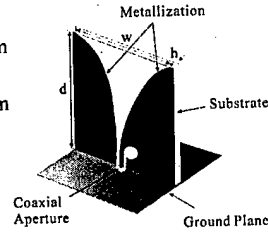

## Finite Array Antennas

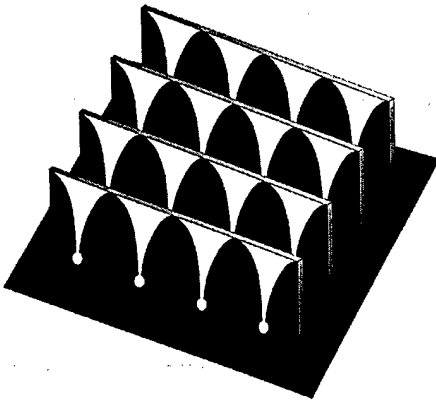

Flared notch (vivaldi) antenna array

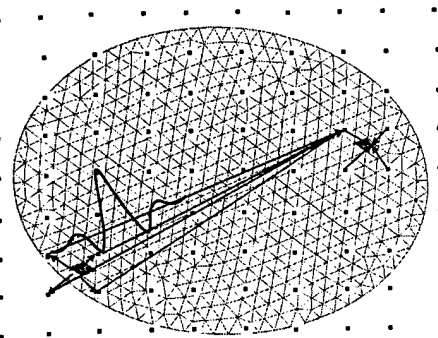

Adaptive integral method:

- Two sets of meshes
- Auxiliary sources equivalently represent the unknowns
- Use of FFTs

## Finite Array Antennas

- ⇒ Radiation pattern from antenna element #1
- ⇒ Normalized Poynting vector extends from origin to the colored surface

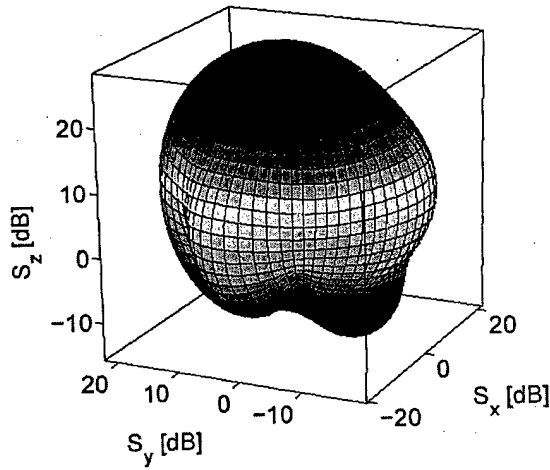
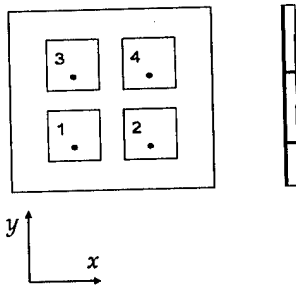

## Finite Array Antennas

- > 4x4 scattering matrix: full characterization of mutual coupling between antenna elements
- >  $S_{ij}$  computed for frequency range from 1 GHz to 3 GHz

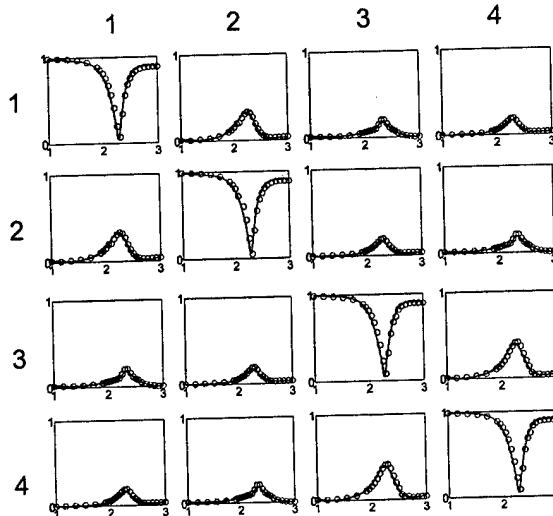
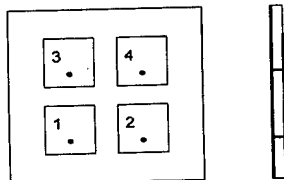

## Antenna/Platform Interaction

### Final combined matrix system:

1. The system is usually very large; hence, iterative solution is the only choice.
2. Unfortunately, convergence is very slow.

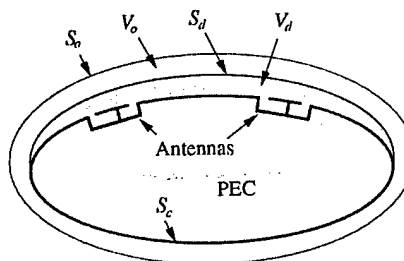

$$\begin{bmatrix}
 A_{(H_{S_c}, H_{S_c})} & 0 & 0 & 0 & A_{(H_{S_c}, H_{V_o})} & A_{(H_{S_c}, H_{S_o})} & 0 & 0 \\
 0 & A_{(E_{V_d}, E_{V_d})} & A_{(E_{V_d}, E_{S_d})} & 0 & 0 & 0 & 0 & 0 \\
 0 & A_{(E_{S_d}, E_{V_d})} & A_{(E_{S_d}, E_{S_d})} & A_{(E_{S_d}, H_{S_d})} & 0 & 0 & 0 & 0 \\
 0 & 0 & A_{(H_{S_d}, E_{S_d})} & A_{(H_{S_d}, H_{S_d})} & A_{(H_{S_d}, H_{V_o})} & A_{(H_{S_d}, H_{S_o})} & 0 & 0 \\
 A_{(H_{V_o}, H_{S_c})} & 0 & 0 & A_{(H_{V_o}, H_{S_d})} & A_{(H_{V_o}, H_{V_o})} & A_{(H_{V_o}, H_{S_o})} & 0 & 0 \\
 A_{(H_{S_o}, H_{S_c})} & 0 & 0 & A_{(H_{S_o}, H_{S_d})} & A_{(H_{S_o}, H_{V_o})} & A_{(H_{S_o}, H_{S_o})} & A_{(H_{S_o}, E_{S_o})} & 0 \\
 B_{(E_{S_o}, H_{S_c})} & 0 & B_{(E_{S_o}, E_{S_d})} & B_{(E_{S_o}, H_{S_d})} & 0 & A_{(E_{S_o}, H_{S_o})} & A_{(E_{S_o}, E_{S_o})} & 0
 \end{bmatrix}
 \begin{bmatrix}
 x_{H_{S_c}} \\
 x_{E_{V_d}} \\
 x_{E_{S_d}} \\
 x_{H_{S_d}} \\
 x_{H_{V_o}} \\
 x_{H_{S_o}} \\
 x_{E_{S_o}}
 \end{bmatrix}
 =
 \begin{bmatrix}
 0 \\
 b_{E_{V_d}} \\
 0 \\
 0 \\
 0 \\
 0 \\
 0
 \end{bmatrix}$$

$\swarrow$        $\nwarrow$        $\swarrow$        $\nwarrow$        $\swarrow$        $\nwarrow$        $\swarrow$        $\nwarrow$   
 BIE full matrices

## Antenna/Platform Interaction

### ABC-Based Preconditioner:

Replace CFIE by 1<sup>st</sup>-order ABC:

$$\hat{n}_o \times \mathbf{E}(\mathbf{r}) + Z_0 \hat{n}_o \times \hat{n}_o \times \mathbf{H}(\mathbf{r}) = 0 \quad \mathbf{r} \in S_o$$

Combined system becomes:

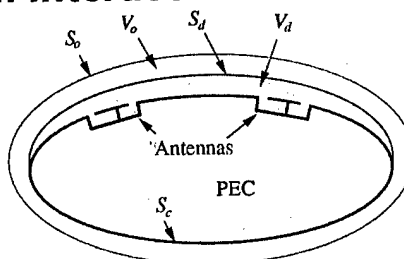

$$\begin{bmatrix}
 A_{(H_{S_c}, H_{S_c})} & 0 & 0 & 0 & A_{(H_{S_c}, H_{V_o})} & A_{(H_{S_c}, H_{S_o})} & 0 & 0 \\
 0 & A_{(E_{V_d}, E_{V_d})} & A_{(E_{V_d}, E_{S_d})} & 0 & 0 & 0 & 0 & 0 \\
 0 & A_{(E_{S_d}, E_{V_d})} & A_{(E_{S_d}, E_{S_d})} & A_{(E_{S_d}, H_{S_d})} & 0 & 0 & 0 & 0 \\
 0 & 0 & A_{(H_{S_d}, E_{S_d})} & A_{(H_{S_d}, H_{S_d})} & A_{(H_{S_d}, H_{V_o})} & A_{(H_{S_d}, H_{S_o})} & 0 & 0 \\
 A_{(H_{V_o}, H_{S_c})} & 0 & 0 & A_{(H_{V_o}, H_{S_d})} & A_{(H_{V_o}, H_{V_o})} & A_{(H_{V_o}, H_{S_o})} & 0 & 0 \\
 A_{(H_{S_o}, H_{S_c})} & 0 & 0 & A_{(H_{S_o}, H_{S_d})} & A_{(H_{S_o}, H_{V_o})} & A_{(H_{S_o}, H_{S_o})} & A_{(H_{S_o}, E_{S_o})} & 0 \\
 \cancel{B_{(E_{S_o}, H_{S_c})}} & 0 & \cancel{B_{(E_{S_o}, E_{S_d})}} & \cancel{B_{(E_{S_o}, H_{S_d})}} & 0 & A_{(E_{S_o}, H_{S_o})} & A_{(E_{S_o}, E_{S_o})} & 0
 \end{bmatrix}
 \begin{bmatrix}
 x_{H_{S_c}} \\
 x_{E_{V_d}} \\
 x_{E_{S_d}} \\
 x_{H_{S_d}} \\
 x_{H_{V_o}} \\
 x_{H_{S_o}} \\
 x_{E_{S_o}}
 \end{bmatrix}
 =
 \begin{bmatrix}
 0 \\
 b_{E_{V_d}} \\
 0 \\
 0 \\
 0 \\
 0 \\
 0
 \end{bmatrix}$$

$\swarrow$        $\nwarrow$        $\swarrow$        $\nwarrow$        $\swarrow$        $\nwarrow$        $\swarrow$        $\nwarrow$   
 Sparse matrices

- Note:
1. A large, purely sparse matrix.
  2. A very effective preconditioner.

### ABC-Based Preconditioner

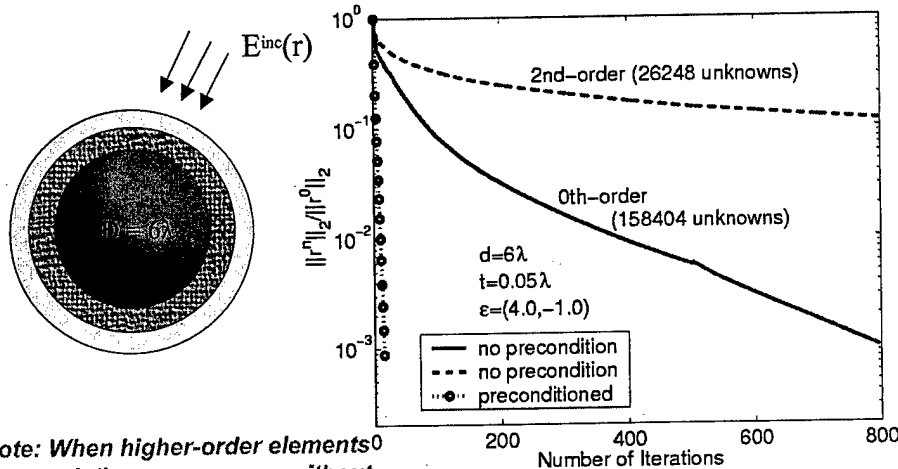

Note: When higher-order elements<sup>0</sup> are used, the convergence without preconditioning is even slower, whereas the convergence with preconditioning remains the same.

Unknowns = 158,404  
 0<sup>th</sup>-order prism elements

### Antenna/Platform Interaction

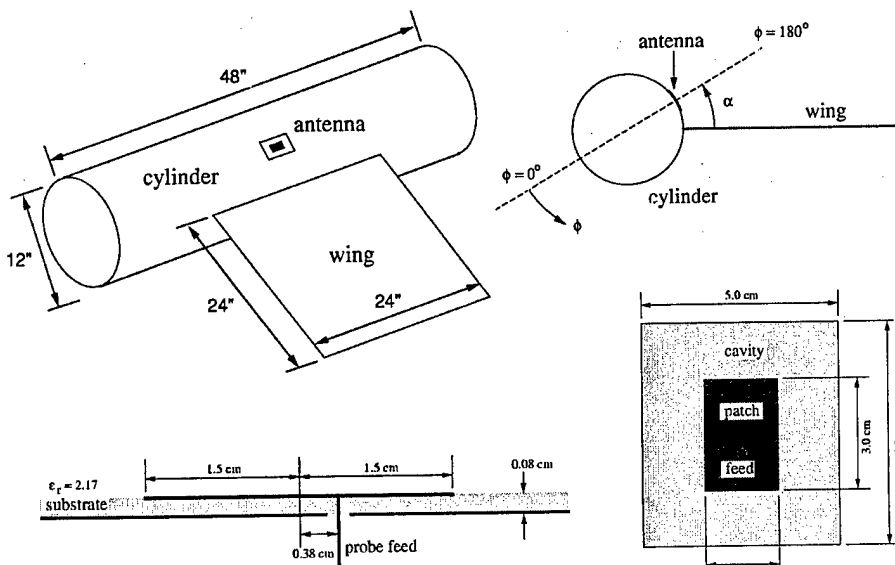

### Antenna/Platform Interaction

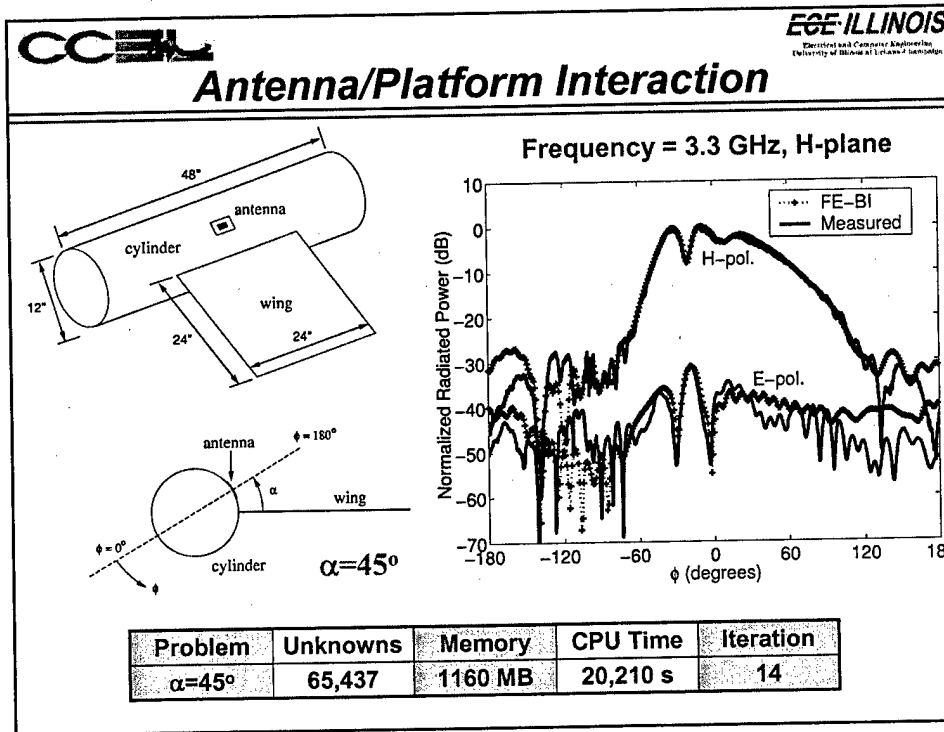
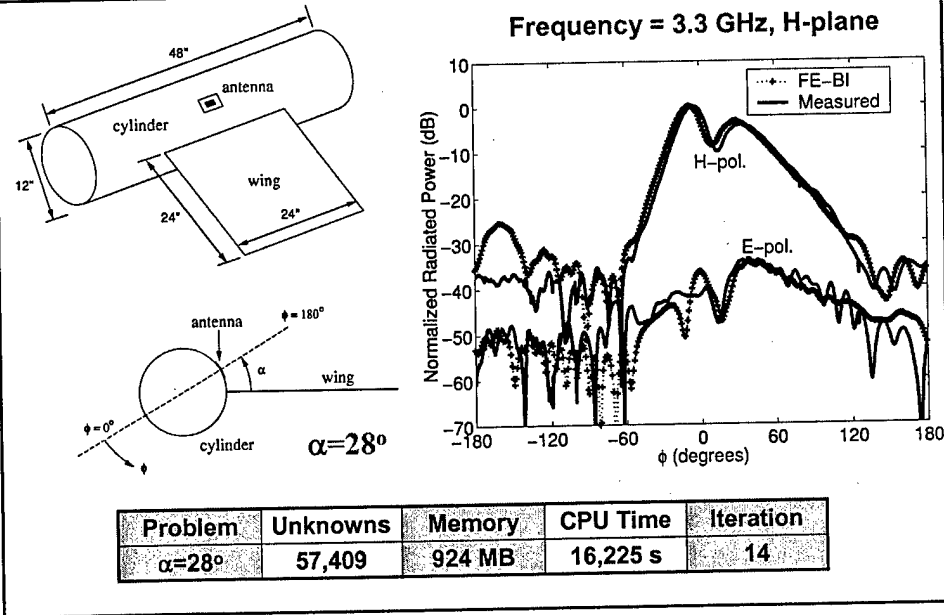

## Conclusion

A complete set of FEM-based simulation techniques:

- Infinite periodic phased arrays
- Finite-by-infinite array antennas
- Arbitrary finite array antennas
- Conformal antennas mounted on a platform

Common characteristics:

- Higher-order geometrical modeling
- Higher-order field discretization
- Accurate antenna feed modeling
- BIE as exact mesh truncation
- FMM & AIM for BIE evaluation
- Effective preconditioner