

APPLICATION		REVISION HISTORY			
NEXT ASS'Y	USED ON	REV	DESCRIPTION	DATE	APPROVED
MODIOS	ASWETS	--	INITIAL RELEASE RN C58295-2	11-4-04	C. Ireland

Copyright © 2004 General Dynamics ALL RIGHTS RESERVED.

ALL SHEETS ARE THE SAME REVISION STATUS

	CONTR N61339-04-C-0051	GENERAL DYNAMICS DECISION SYSTEMS ORLANDO, FLORIDA 32826			
	ISS C58295-2 (-) 11-4-04	TITLE			
	APPROVALS	ADVANCE SOLDIER WEARABLE EMBEDDED TRAINING SYSTEM (ASWETS) FINAL REPORT			
	DWN: D. Hong				
	TPS LIC: G. Hall, PL				
	SQA: E. Bray				
	MATL: NA				
	MNF: NA	SIZE	CAGE CODE	DWG NO.	
	ENG: G. Hall, PL	A	1VNY6	98-P59921E	
	CUST:	SCALE: NONE			SHEET 1 OF 56

Approved For Public Release, Distribution is unlimited.

Advanced Soldier Wearable Embedded Training System Final Report

Contract Number N61339-04-C-0051



CDRL A002
October 21, 2004

Prepared for:
RDECOM Simulation and Training Center
12350 Research Parkway
Orlando, Florida 32826

Prepared by:
General Dynamics Decision Systems
Battle Management Systems Division
12424 Research Parkway Suite 390
Orlando, Florida 32826

Report Documentation Page

Form Approved
OMB No. 0704-0188

Public reporting burden for the collection of information is estimated to average 1 hour per response, including the time for reviewing instructions, searching existing data sources, gathering and maintaining the data needed, and completing and reviewing the collection of information. Send comments regarding this burden estimate or any other aspect of this collection of information, including suggestions for reducing this burden, to Washington Headquarters Services, Directorate for Information Operations and Reports, 1215 Jefferson Davis Highway, Suite 1204, Arlington VA 22202-4302. Respondents should be aware that notwithstanding any other provision of law, no person shall be subject to a penalty for failing to comply with a collection of information if it does not display a currently valid OMB control number.

1. REPORT DATE 21 OCT 2004	2. REPORT TYPE N/A	3. DATES COVERED -			
4. TITLE AND SUBTITLE Distributed Medical Training for Force Mobilization and Disaster Reponse		5a. CONTRACT NUMBER N61339-04-C-0051			
		5b. GRANT NUMBER			
		5c. PROGRAM ELEMENT NUMBER			
6. AUTHOR(S)		5d. PROJECT NUMBER			
		5e. TASK NUMBER			
		5f. WORK UNIT NUMBER			
7. PERFORMING ORGANIZATION NAME(S) AND ADDRESS(ES) General Dynamics Decision Systems, Battle Management Systems Div., 12424 Research Parkway Suite 390, Orlando, FL 32826		8. PERFORMING ORGANIZATION REPORT NUMBER			
9. SPONSORING/MONITORING AGENCY NAME(S) AND ADDRESS(ES)		10. SPONSOR/MONITOR'S ACRONYM(S)			
		11. SPONSOR/MONITOR'S REPORT NUMBER(S)			
12. DISTRIBUTION/AVAILABILITY STATEMENT Approved for public release, distribution unlimited					
13. SUPPLEMENTARY NOTES The original document contains color images.					
14. ABSTRACT					
15. SUBJECT TERMS					
16. SECURITY CLASSIFICATION OF:			17. LIMITATION OF ABSTRACT UU	18. NUMBER OF PAGES 56	19a. NAME OF RESPONSIBLE PERSON
a. REPORT unclassified	b. ABSTRACT unclassified	c. THIS PAGE unclassified			

Table of Contents

1	Introduction.....	6
1.1	Summary of Tasks	7
1.2	Summary of Results.....	7
1.3	Conclusion and Lessons Learned.....	8
1.4	Plans for the Future.....	10
2	Advanced Soldier Wearable Embedded Training System.....	12
2.1	Background.....	12
2.2	Hardware Diagrams	13
2.2.1	Hardware Components.....	13
2.2.2	Hardware Interfaces	17
2.2.3	Hardware Specifications	19
2.2.4	Operating Systems	26
2.3	Software Diagrams.....	26
2.3.1	Software Components.....	27
2.3.2	Software Interfaces	33
2.3.3	User Interfaces	34
2.3.4	Software Type.....	35
2.3.5	Programming Languages	35
2.3.6	Information Classification	35
2.3.7	Licensing.....	35
2.4	Using the ASWETS System	35
2.4.1	Starting the System	35
2.4.2	Using the System	37
3	3D Mission Planning.....	41
3.1	Introduction.....	41
3.2	Software Components.....	41
3.2.1	Architecture.....	41
3.2.2	Software Type.....	42
3.2.3	Programming Languages	42
3.2.4	Information Classification	42
3.2.5	Licensing.....	42
3.3	Using the 3D Mission Planner Plug-In	43
3.3.1	Loading/Unloading the 3D Mission Planner Plug-in.....	43
3.3.2	Movement and View Modes.....	44
3.3.3	Creating Entities and Points of Interest	44
3.3.4	Creating Routes and Waypoints.....	45
3.3.5	Assigning Routes to Entities.....	46
3.3.6	Selecting and Moving Objects	46
3.3.7	Network and Remote Objects	47
3.3.8	Following Routes	48
3.3.9	Follow the Leader	48
3.3.10	Saving/Restoring Mission Planner Files.....	49
4	Appendix.....	50
4.1	Monthly Report Summary	50

4.1.1	April Status Report	50
4.1.2	May Status Report.....	52
4.1.3	June / July Status Report.....	54

Table of Tables

Table 1: ASWET Tasks	7
----------------------------	---

Table of Figures

Figure 1: ASWETS System	6
Figure 2: DSS Wireless System during Culminating Event	9
Figure 3: ModIOS Dismounted Soldier Simulator	13
Figure 4: High Level Hardware Diagram	13
Figure 5: ASWETS Wearable Front View	14
Figure 6: ASWETS Wearable Rear View	15
Figure 7: Soldier Control Unit (SCU).....	16
Figure 8: Weapon Controller	16
Figure 9: Joystick Buttons	17
Figure 10: DSS Detailed Hardware Diagram	19
Figure 11 Tracker Electronics Board.....	24
Figure 12 Sensor Battery Charger.....	25
Figure 13: Leader Tablet Display	26
Figure 14: High Level DSS Software Block Diagram.....	26
Figure 15: Detailed DSS Software Block Diagram	27
Figure 16: ModIOS Niu Shortcut	36
Figure 17: ModIOS NIU	36
Figure 18: ASWETS Program Shortcut.....	36
Figure 19: ASWETS Program Window	37
Figure 20: ASWETS Graphical Display.....	38
Figure 21: Joystick Button Configuration.....	39
Figure 22: Simulated Land Warrior View	40
Figure 23: High Level Software Architecture	41
Figure 24: Detailed Level Software Architecture	42
Figure 25: 3D Mission Planner Plug-In Properties.....	44
Figure 26: 3D Mission Planner Plug-In View Mode Icons	44
Figure 27: 3D Mission Planner Plug-In Create Menu	45
Figure 28: A selected Entity	45
Figure 29: Route Menu	46
Figure 30: An Entity with an assigned route	46
Figure 31: Remote Route, Entity, and Point of Interest.....	47
Figure 32: Follow Route popup menu	48
Figure 33: Saving a Mission Planner file.....	49

1 Introduction

General Dynamics enhanced their existing man wearable system, the Dismounted Soldier Simulation (DSS), to bring advanced training capabilities and realism into the existing dismounted embedded simulation environment at RDECOM's Simulation and Training Technology Center. System enhancements combined with immersive hardware provides virtual reality IC's (Individual Combatants) with body and weapon tracking, head mounted displays and options including body worn CPU and graphics processors for fully wireless virtual reality. The result of this research and development was the Advanced Soldier Wearable Embedded Training System or ASWETS.

Research included packaging of smaller/lighter computer systems, investigation of new wearable six Degree of Freedom (6-DOF) body/weapon tracking systems, and new software interfaces and capabilities. Software capabilities such as, increased weapon accuracy, increased virtual character realism, and incorporation of Land Warrior C4ISR sensor data into the system were developed. The goal of the resulting development was to provide a train anywhere capability to the soldier.

The General Dynamics S2Focus Tool Suite was also enhanced, via a plug-in module, with 3D Mission Planning and Rehearsal capability. The 3D Mission Planning and Rehearsal Plug-In allows the squad leader to move around in a virtual database, create scenarios for mission rehearsal and lay down points of interests in real time along with controlling the viewpoint or camera of other users. This software is loaded on a Tablet PC, which acts as the leader's display on the future Land Warrior System.

Both the ASWETS simulator and 3D Mission Planner Plug-In both utilize commercial off the shelf software (COTS) and were designed, both in hardware and software, to be configurable and extendable to meet a wide range of simulation and training objectives.



Figure 1: ASWETS System

1.1 Summary of Tasks

General Dynamics executed the following high-level tasks under the ASWETS Project.

DSS and Thermite Integration
Wearable 6–DOF Tracking System
Thermite Performance Enhancements
Increased Weapon Accuracy and Aiming
Land Warrior Like Capabilities & Sensor Feeds
Support at Fort Benning for Culminating Event
3D Mission Planning/Rehearsal Capability

Table 1: ASWETS Tasks

1.2 Summary of Results

- DSS and Thermite Integration
 - The ASWETS software and hardware components were successfully integrated on both the pre-production and post-production Thermite Systems.
- 6 – DOF Tracking System
 - The new wearable 6 – DOF Tracking system (Ascension Technologies) was successfully integrated into the ASWETS software and hardware interfaces. The system independently tracks the head, leg (for determining the user’s stance), and weapon. This system was integrated with a 3-DOF inertia sensor (Intersense InertiaCube2) to provide a reference orientation for the 6-DOF system.
- Thermite™ Performance Enhancements
 - Numerous enhancements were made to the ASWETS software to optimize its performance on the Thermite wearable computer system. Major enhancements included, but were not limited to:
 - Intersection enhancements
 - Clamping / Terrain Intersection enhancements
 - Graphical overlay enhancements
 - Bumper Labels / Soldier Tag enhancements for rendering
- Increased Weapon Accuracy and Aiming
 - 6 – DOF Sensors were used to track the weapon in the virtual scene. This allowed the weapon to support changes in heading, pitch, and roll, but also movements in the X, Y, and Z planes (location). The goal was to allow realistic aiming of the virtual weapon.
 - Enhanced M4 Gun model with Sight, Enhanced M203 Grenade Launcher, and standard M4 Gun models were developed.

- Land Warrior Like Capabilities
 - Look Around Corners with simulated weapon day camera
 - Successfully added ability to display 2nd Viewport.
 - Utilized 2nd Viewport to display the weapon's camera viewpoint or point of view, so the user can effectively use the weapon sight to look around corners. This also required the integration of a 6-DOF tracker to track the weapon's position.
- Supported Culminating Event at Fort Benning, GA
 - Successfully supported Culminating Event at Fort Benning
 - Created smoke models for ground smoke (green, blue, red, etc)
 - Made code modifications to make it easier to traverse terrain and move in and out of doorways.
 - Had minimal system failures / system downtimes. Failures were mostly hardware related due to cables becoming disconnected.
 - Made code modifications to support existing SVS simulators implementation of stance, walking, etc.
 - Interoperable with both OneSAF TestBed and SVS simulators running at Fort Benning simulation facilities.
- 3D Mission Planning Capability
 - Successfully created 3D Mission Planning and Rehearsal Plug-In for S2Focus Viewer component
 - Allows rotation of placement of virtual objects in the scene (entities, tanks, infantry, points of interest) in a drag and drop manner.
 - Provides creation and assignment of waypoints to entities.
 - Provides capability to export a scenario in the S2Focus Mission Planner (.mpl) file format.
 - Uses the simulation network to distribute points of interest (POI), waypoints, entities, and routes among all users. This allows a remote 3D Mission Planning Plug-In to display entities, routes and POIs that other leaders are creating.
 - Can slave remote S2Focus 3D Mission Planning Plug-Ins off the leader's display. (Slave View mode)

1.3 Conclusion and Lessons Learned

General Dynamics learned valuable lessons by participating in the culminating event at Fort Benning, GA. We learned that different companies and different systems still interpret the Distributed Interactive Simulation (DIS) standard in different ways. An example of this is how one represents walking, kneeling, crawling, etc. We noticed that the existing SVS™ systems from Advanced Interactive Systems, Inc. did not update corresponding Stance codes (DIS

appearance bits) out on the simulation network to represent their state when entering the walking, running or crawling state. Thus, to be interoperable with the current system, code had to be modified to not only to support the stance code bits, but also the way the SVS represented the different states. This was not a problem for the ASWETS system since we had the opportunity to do some pre-integration work at the RDECOM facility in Orlando, FL prior to the culminating event. The pre-integration was invaluable to making the culminating event a success.



Figure 2: DSS Wireless System during Culminating Event

In addition, many of the systems experienced database problems that led to soldiers falling through the floor and jumping to the roof. This may be in part due to the fact that the systems were using a relatively new database and not fully tested.

Another invaluable lesson that we realized was the need for locking connectors for all cable connects. Many soldiers would forcefully move in the system, sometimes causing cable connections to disconnect and result in the system having to be restarted. Future versions of the DSS system should be developed with better connectors for this reason.

Finally, another observation was made against the processing power of the Quantum 3D Thermite™. While this miniaturized and rugged computer has an extremely small form factor, it was evident that this machine did not have the processing power found in most high-end laptops today. This limitation seemed to be the driving force that affected the number of entities and animations, the complexity of the terrain database, and the overall frame rate of the system. The main limitation today is the processing power of the current 1.0 GHz Transmeta® Crusoe® CPU. Also the limitation of on 512MB of system memory was a factor

with large terrain databases or large exercises. Hopefully as technology advances and more research is completed, a more powerful Thermite or similar system will be available.

The value of the increased weapon accuracy was also accessed during the event. Soldiers were questioned to whether having the ability to aim the virtual weapon as they would a real weapon was of added benefit. This capability was provided due to the new 6-DOF tracking system that was incorporated into the DSS system. The result of the trial was a determination that, because of the limited field of view of current wearable helmet mounted displays (HMDs) (< 30 degrees), the display of the weapon site (to allow proper weapon aiming) greatly limited the user's field of view. The availability of new HMDs with larger fields of view should lessen this drawback. Some users also experienced tracking or accuracy errors in the weapon's perceived location. Improving the tracking accuracy will be invested in the future to reduce the perceived error.

Another goal of the culminating event was to provide simulated voice/radio communication for all players, including the existing SVS projection systems and the new wireless systems from General Dynamics, Quantum3D, and AIS. The Ft. Benning simulation facility currently uses the ASTi simulated radio system. General Dynamics provided our ModIOS® Voice Communicator software to all participants. The ModIOS Voice software can run on a standard Windows™ system with no special hardware necessary other than a standard sound card. The ModIOS Voice software running on the General Dynamics DSS system was configured and interoperable with the ASTi radios at the Ft. Benning simulation center. However, due to integration difficulties and delays not all vendors were able to integrate the Voice software on their systems prior to the trials with the soldiers. Therefore, simulated voice/radio communication was not used during the event.

Overall, the culminating event was a success. The DSS/ASWETS system had minimal software and hardware failures and was interoperable with the SAF, SVS stand up simulators, SVS desktop simulators, and the other two wireless IC systems. The soldiers seemed to be able to learn the functionality of the wireless simulators so that they could provide valuable mission rehearsal and training capabilities.

1.4 Plans for the Future

General Dynamics plans to utilize its knowledge obtained through the 2004 culminating event, and past simulation experience to build upon technologies and capabilities developed by General Dynamics under RDECOM's Embedded Training & Simulations for Dismounted Soldiers (ETS-DS) STO in FY04.

The goal is provide a complete embedded training system, with Mission Rehearsal and After Action Review capabilities, that closely resembles the operational systems being developed on the Land Warrior and Future Force Warrior programs and integrated with Future Combat System (FCS) prototype vehicles at RDECOM's STTC facility. This will allow the capability to conduct advanced embedded dismounted and mounted training research and provides a test-bed for studying advanced embedded training technologies.

IC Improvements include but are not limited to:

- Integration of the existing ASWETS system with the vest, harness belt and cables currently being using on the LW-SI program along with the common single battery type being used on the LW-SI program. This also includes the reuse of the actual Soldier Control Unit (SCU) and Weapon User Interface (WUI) components of the LW-SI ensemble. The goal being to closely resemble the actual LW-SI ensemble to demonstrate the capability for embedded training on an operational system
- Provide the capability for the embedded soldier to provide targeting and target handoff to mounted and/or robotic embedded system.
- Investigation and integration of dual/stereo version of the LW-SI Monocle to provide both LW situational awareness and video display along with the increased field of view and stereo virtual representation of the battlefield.
- Enhance the software related to 6-DOF tracking system to provide increased weapon to head aiming accuracy and reduce the system's form factor.
- Add capability to the DSS software to allow users to physically kick down doors and throw virtual grenades.
- Increased representation of other fully immersed participants in the virtual environment. This provides accurate visual representation of participants using fully immersed wearable systems by using the actual position of each immersed participant's head and weapon system.
- Provide enhanced dismounted/mounted interoperability allowing dismounted soldiers to mount and dismount (or attach/detach) to other simulation models/entities (such as the ICV) during a simulation.
- Improve the realism of the system by adding more weapon types and equipment (XM8, OICW, flares, flash-bangs, etc).
- Enhanced realism by changing the virtual physical performance model in the DSS software to account for the player's current health and endurance.
- Enhancement of sensory feedback to provide more realism with new types of sensors.

Mission Planning Improvements include but are not limited to:

- Develop a common public interface specification and protocol for performing distributed Mission Rehearsal and AAR/Debrief

- Enhance the current 3D Mission Planning capability developed on the ETS-DS STO based on the final MR/AAR message and protocol specification.
 - Complete the remote control using the new message specification within the DSS system.
 - Add display of overlays in S2Focus' existing 2D map visualization mode.
 - Add the ability to inject events during a rehearsal.
 - Demonstrate interoperability with the Stryker Embedded Training Module (ETM) computer system.
- Build upon the existing ModIOS/S2Focus AAR and 3D MR components and capabilities to provide embedded AAR/Debrief capability.
 - Remote control of data recorder playback within 3D leader display.
 - Selection of saved quick jump-to views/bookmarks (captured during live play).
 - Instructor selection/highlighting of objects or points of interest on the displays of all embedded participants during AAR.
 - Replay of voice communications to all embedded participants.
 - Display of key statistics to embedded participants.

2 Advanced Soldier Wearable Embedded Training System

2.1 Background

General Dynamics C4 Systems has developed a robust COTS system for training of dismounted soldiers in a wireless immersive environment. This system was designed to be interoperable with common simulation protocols like DIS and HLA and database formats like OpenFlight™. The system provides the capability to allow the user to move freely while completely immersed in a realistic virtual environment (with a properly tracked weapon system) without the restraint of cables or wires. The system uses the APEX™ advanced gaming-rendering engine for high performance and realistic visual environment. The man wearable system is highly extendable and flexible to allow the easy addition of new capabilities and features.

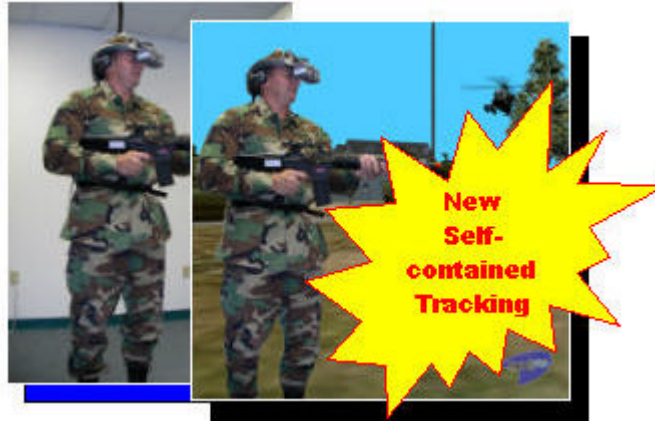

Figure 3: ModIOS Dismounted Soldier Simulator

2.2 Hardware Diagrams

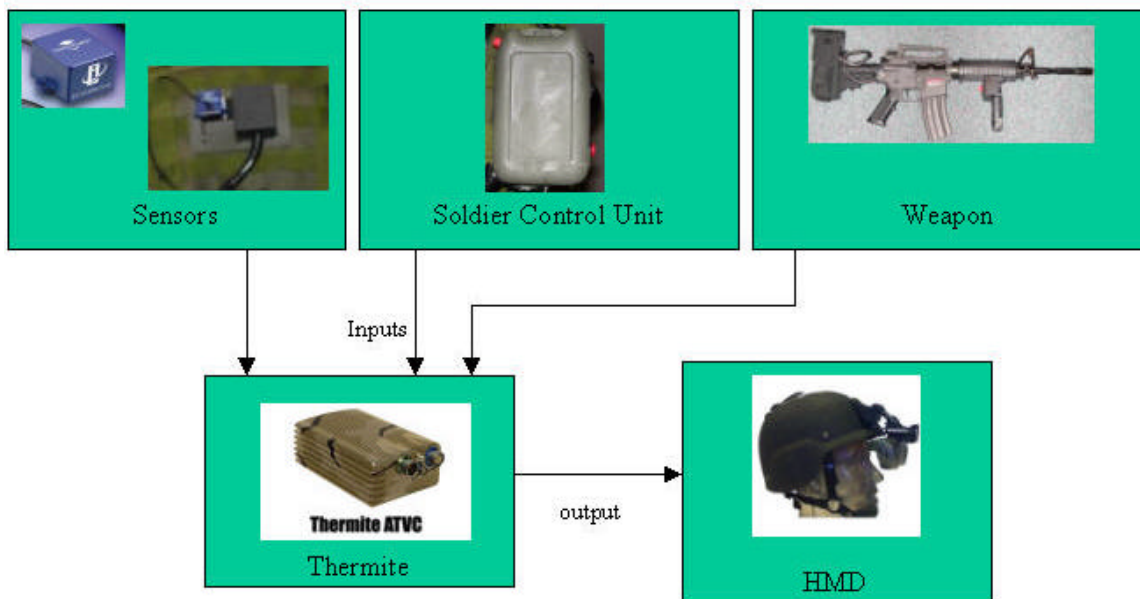

Figure 4: High Level Hardware Diagram

2.2.1 Hardware Components

2.2.1.1 ASWETS

The ASWETS system is composed of the following hardware pieces:

1. Computer sub-assembly
 - a. Quantum 3D Thermite Computer

- b. Thermite Batteries
 - c. 4-port Powered USB Hub powered via Thermite External Power connector.
 - d. Thermite Video cables, Thermite I/O cables, Thermite power cable
 - e. USB License Dongle (Advanced Visualization Extension)
 - f. PS2 Keyboard
2. Sensor sub-assembly (6 DOF Tracker)
- a. Ascension 6-DOF (Degrees of Freedom) Sensor Controller Card and Tracker
 - b. 3 Sensors (Helmet, Weapon, Leg/Stance)
 - c. Intersense Inertiacube2 (USB) (3-DOF)
 - d. 6-DOF Tracker Batteries

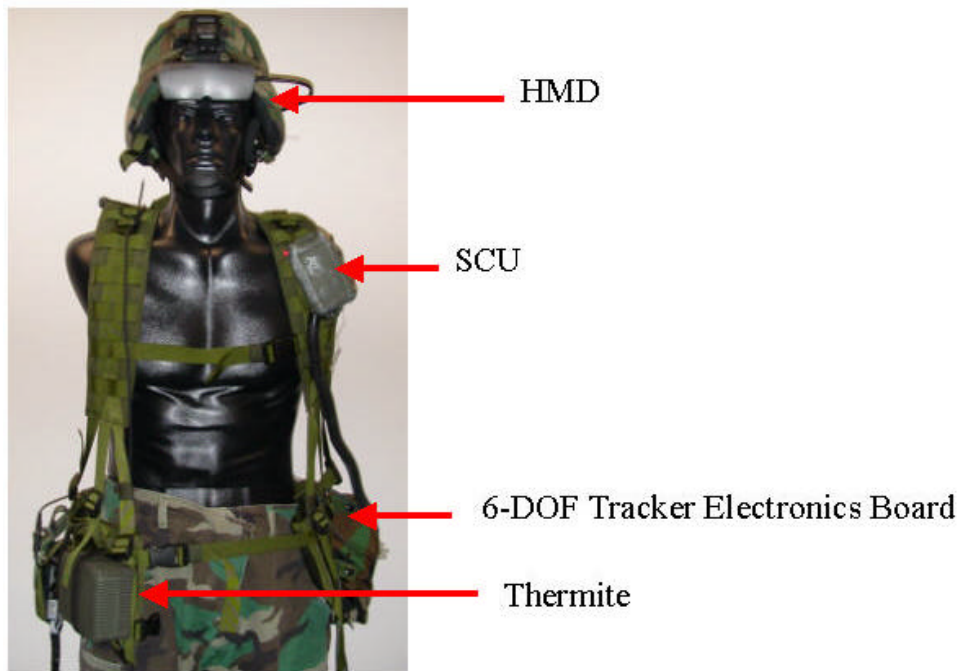

Figure 5: ASWETS Wearable Front View

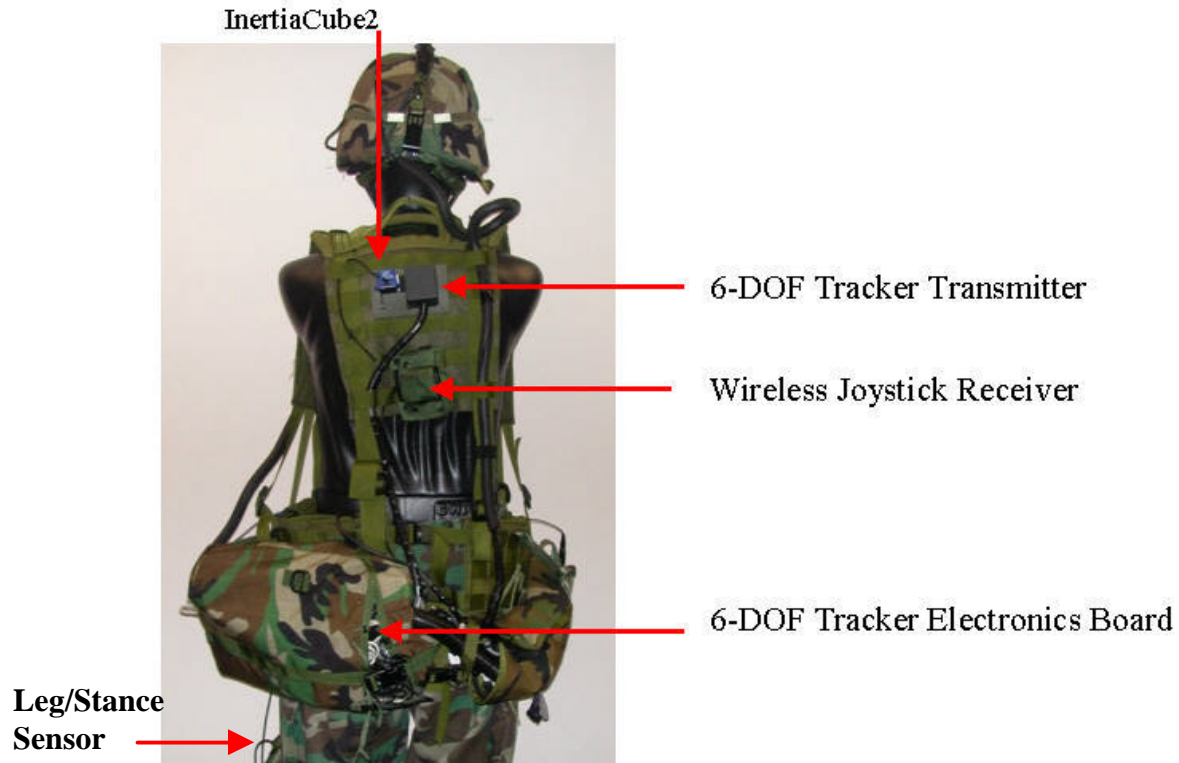

Figure 6: ASWETS Wearable Rear View

3. Helmet sub-assembly
 - a. Integrated Speakers
 - b. Integrated Microphone
 - c. I-O Glasses HMD with NVG (Night Vision Goggle) mount.

4. Soldier Control Unit (SCU) sub-assembly
 - a. Volume Control Knob
 - b. Push to Talk Button
 - c. Mouse Thumb pad
 - d. Right mouse and Left mouse buttons
 - e. VOX Switch

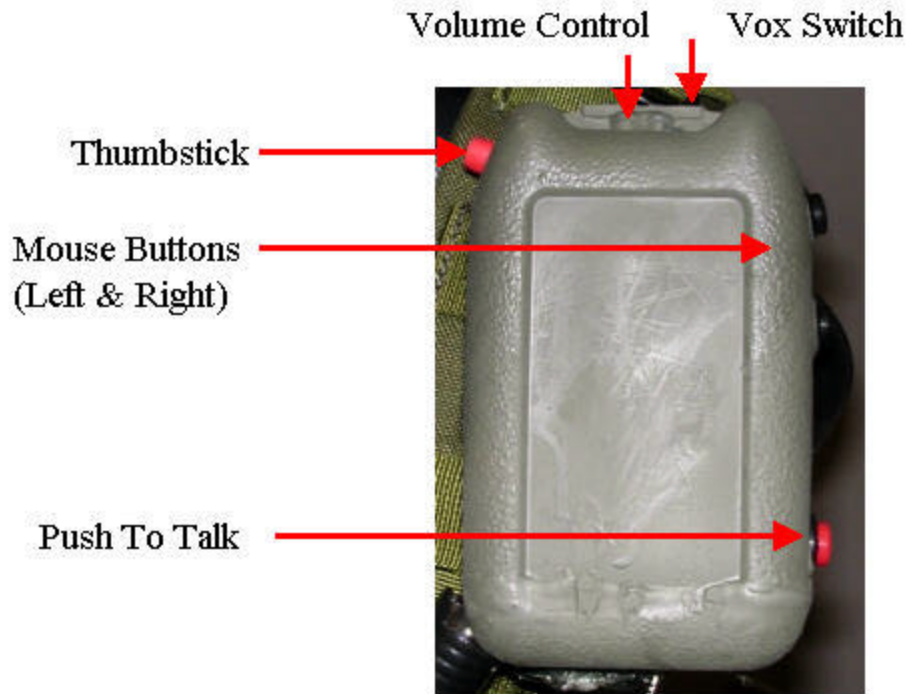
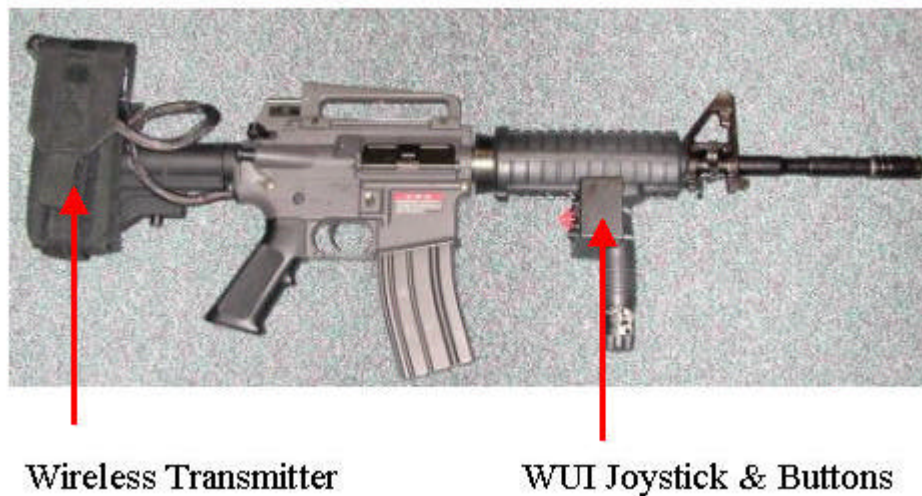

Figure 7: Soldier Control Unit (SCU)

5. Weapon sub-assembly
 - a. Integrated Wireless Controller (Logitech Wingman Gamepad)
 - b. Wireless Receiver (Logitech Wingman Gamepad)
 - c. Mock M4A1 Weapon
 - d. 4 AA Batteries
 - e. Configurable Joystick button assignments



Wireless Transmitter

WUI Joystick & Buttons

Figure 8: Weapon Controller

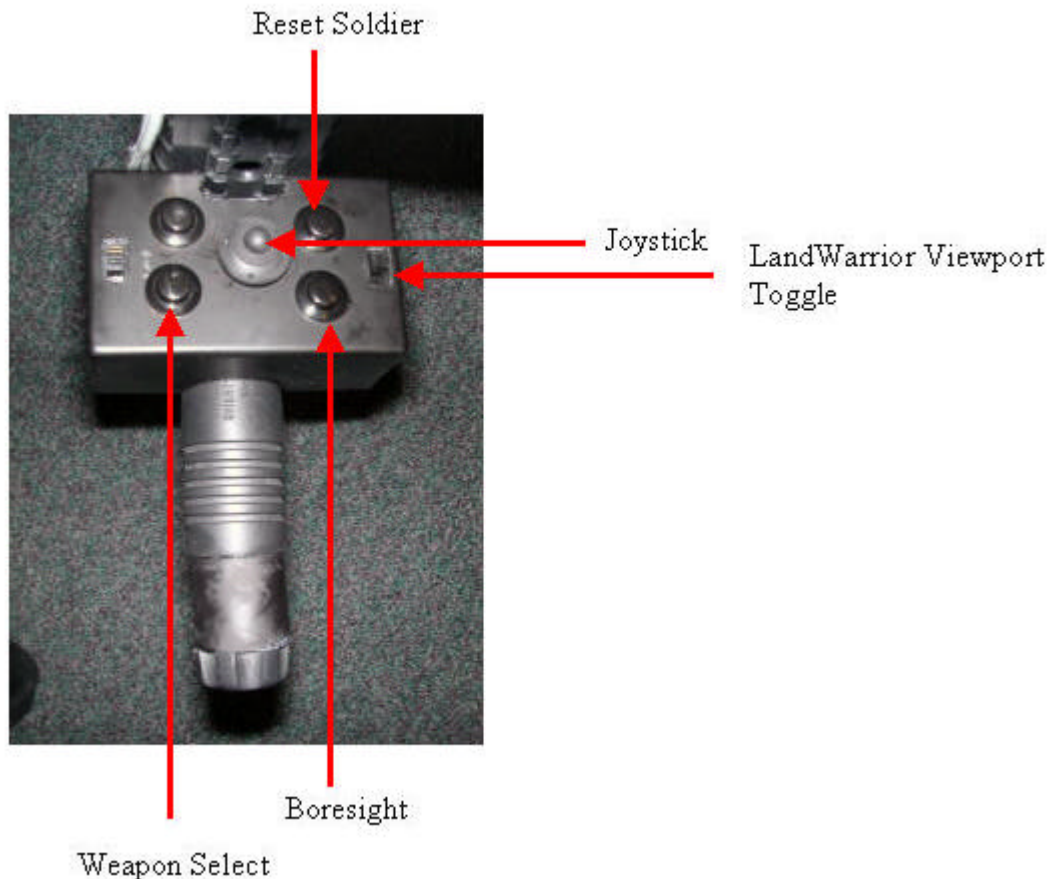

Figure 9: Joystick Buttons

2.2.2 Hardware Interfaces

External Hardware Interfaces

External hardware interfaces consist of:

ASWETS

1. Wireless networking (802.11b) links to connect to simulation

Internal Hardware Interfaces:

Internal hardware interfaces consist of:

ASWETS System

1. Power Cable with voltage regulator is connected to the Thermite's auxiliary power connector that comes out of the Thermite's main power connector. This cable is used to feed power to the 4-port USB Mini-Hub
2. The 4-port USB Mini-Hub is connected to the Thermite's USB external port using a 5V voltage regulator.

3. The Logitech Wireless Wingman Receiver USB connection is connected to the 4-port USB Mini-Hub. This unit is powered by its USB connection.
4. The USB Extension cord and USB Apex License Dongle connects to the 4-port USB Mini-Hub.
5. The Intersense Inertiacube USB connector is connected to the Thermites USB external port. This sensor is powered via its USB connection.
6. The Sensor sub-assembly connects to the Thermite via the serial cable which connects to the Thermite's serial connection (RS-232). The Sensor sub-assembly is powered by the sensor batteries.
7. The HMD connects to the Thermite using the Thermites VGA port and receives power from the HMD Battery.
8. The integrated headphone in the Helmet sub-assembly connects to the audio out port of the Thermite.
9. The integrated microphone in the Helmet sub-assembly connects to the microphone in port of the Thermite.
10. The Solder Control Unit (SCU) has a Serial Cable connection that is converted to a PS2 connection and then connected to the Thermites PS2 Mouse port.
11. A PS2 keyboard plugs into the Thermite's PS2 keyboard port.
12. The Wireless Joystick control in the mock M4A1 weapon is powered by 4 AA batteries.

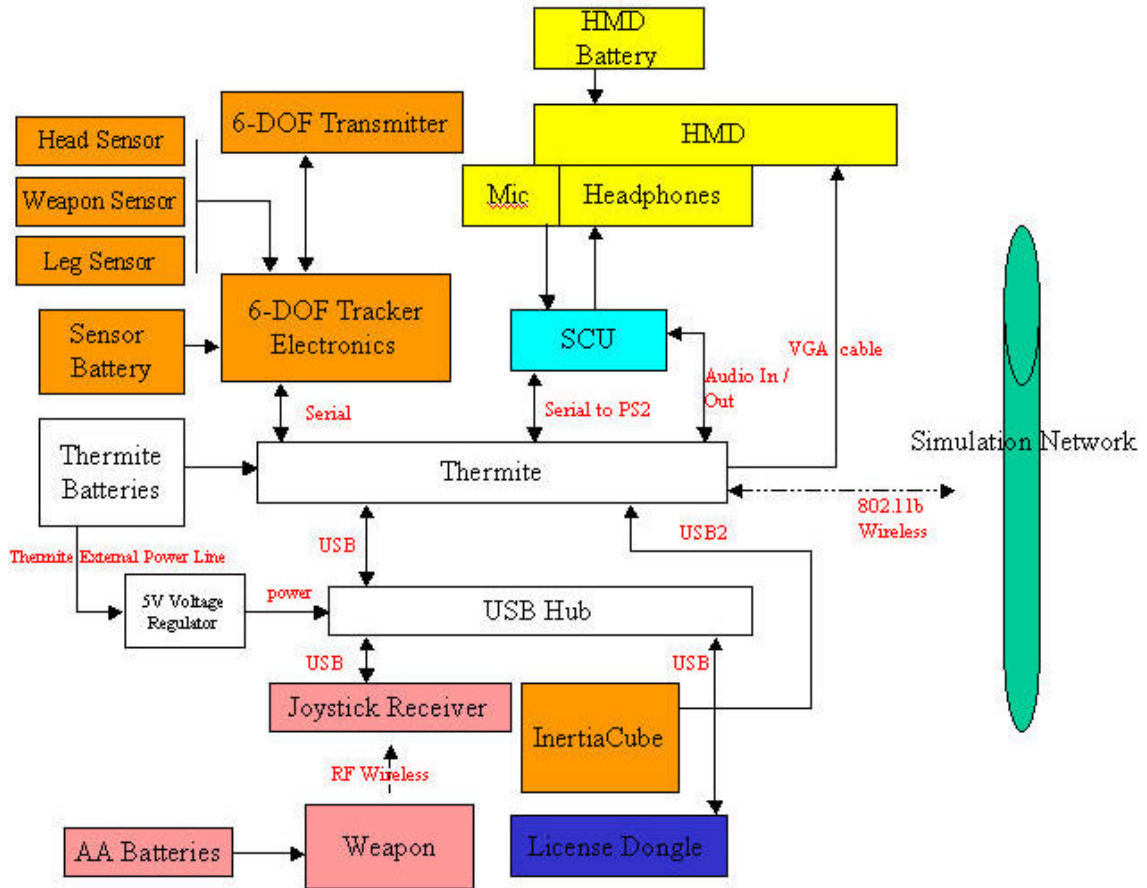

Figure 10: DSS Detailed Hardware Diagram

2.2.3 Hardware Specifications

2.2.3.1 Computer Sub-Assembly

1. [Quantum3D Thermite Tactical Visual Computer](#)
 - CPU: Transmeta Crusoe 5800 1GHz+ with 512Kb L2 Cache
 - Memory: 256 – 512 Mb DDR
 - Operating System: Microsoft Windows 2000 Professional Standard
 - Graphics:
 - nVIDIA GeForceFX Go 5200 GPU with 64Mb DDR memory
 - nView architecture provides dual independent analog computer video outputs up to QXGA (2048 x 1536) with 16 or 32-bit RGBA and Z-buffering (digital requires different configuration).
 - Video output formats: RS-170A, NTSC, PAL, S-Video



- Video input formats: RS-170A, NTSC, PAL, S-Video
- Sync Support for Stereo

- Disk Drive:
 - Shock Resistant 2.5" ATA-6 60Gb HDD
 - 7200 RPM Rotational Speed
 - 100 Mb/sec interface transfer rate
 - Connectivity (LEMO F Series Connectors):
 - 2 x USB 2.0
 - 1 x Serial I/O (RS-232C)
 - 2 x PCMCIA Type II Slots or 1 x PCMCIA Type III. Current configuration uses a [Cisco Aironet 350](#) IEEE 802.11b PCMCIA Card with External Antenna

- Networking:
 - Network Type: Wireless
 - Network Device: PCMCIA Type II
 - Wireless Medium: Direct Sequence Spread Spectrum (DSSS)
 - Device Model: [Cisco Aironet 350](#) AIR-LMC35x
 - Data Rates Supported: 1, 2, 5.5, and 11 Mbps
 - Standard: 802.11b
 - Frequency Band: 2400 MHz to 2489.7 MHz
 - Supported Networks: Infrastructure and Ad Hoc
 - Indoor Range: 40mt @ 11 Mbps , 107mt @ 1 Mbps
 - Outdoor Range: 244mt @ 11Mbps, 610mt @ 1 Mbps
 - OS Compatibility (Relevant): Windows 2000/XP, Linux
 - Antenna: Two MMCX connectors
 - Encryption Key: 128-bit
 - Size: 54mm x 84mm x 3mm [W x L x H]
 - Weight: 40g
 - Operational Temperature: -30°C to 70°C (10%-90% non-condensing)
 - Power: +5V DC +/-5%
 - Power Consumption: 450mA Max

- DC Power Operations:
 - Compatible with BA5590 tactical battery
 - Available Smart Li-Ion commercial battery
 - Redundant Battery Operation Enables Hot-Swap Operation
 - Ships with AC Power Adapter and Charger

- Operational Temperature:
 - -10° C to +55° C with Standard Disk drive
 - Conductively cooled thermal design



- Operational Shock/Vibration
 - Impact-resistant light-weight alloy case
 - Shock 20 Gs with Standard Disk Drive
 - Vibration 2.2 Gs with Standard Disk Drive

 - Operational Altitude
 - 0 to 10,000 ft.

 - Moisture / Contaminants
 - Sealed unit resists particulate and liquid intrusion even when momentarily immersed to 1 meter depth
 - Sealed unit provides immunity to corrosion and contamination from salt spray, fungus, and NBC decontamination
 - Size: 152mm x 99mm x 40.6mm [W x L x H]
 - Weight: 765.4g (not including PCMCIA cards or battery)
2. Thermite Video cables
 - LEMO F Series Connector
 - Primary PC Video Output using DB15 connector
 - Secondary PC Video Output using DB15 connector

 3. Thermite I/O cables
 - LEMO F Series Connector
 - Primary USB 2.0 connector
 - Secondary USB 2.0 connector
 - PS/2 Keyboard connector
 - PS/2 Mouse connector
 - RS-232 Serial DB9 connector

 4. Thermite power cable
 - LEMO F Series Connector
 - Primary External Input Power connector
 - Secondary External Input Power connector
 - Tertiary External Input Power connector
 - Accessory's Output Power connector

 5. Power distribution cable
 - Connects to Thermite's Accessory Output Power connector: 10.8V DC
 - Power Output Connector using 5V Voltage regulator provides 5.0V DC for USB Hub

 6. Power Sub-assembly
 - Dual Rechargeable Battery Packs
 - Battery Chemistry: Lilon



CONTRACT NO.
N61339-04-C-0051

PART NUMBER
98-P5921E

REV
-

Approved For Public Release, Distribution is unlimited.

- Nominal Voltage: 10.8V DC
- Capacity: 5400 mAh
- Size: 139.8mm x 89mm x 19.5mm [W x L x H]
- Weight: 340g
- Dual Battery connection cables attached to primary and secondary external input connectors on Thermite power cable.

7. Targus Mini-Hub

- Color: Silver
- Compliance: FCC, CE
- Size: 2.4"x 1.5"x 0.88" (6 x 3.8 x 2.2 cm)
- USB: USB 2.0
- Weight: 1.4 oz (0.04 kilograms)
- Per-Port Current: 500 mA (with the AC power adapter or "Y" power cable)
- External Power - AC Power Adapter
- DC 5 Volt

2.2.3.2 Head Mounted Display (HMD)

1. Head Mounted Display (HMD) I-Glasses SVGA 3D Pro w/ NVG Mount
 - Resolution: 800 x 600
 - Pixels: 1.44 Million per Display
 - Input: VGA / SVGA / XGA scaled to 800 x 600
 - Field of View: 26 Degrees Diagonal
 - Color Depth: 24 Bit
 - IPD Adjustments: None Required
 - Focus: 13' TBR
 - Eye Relief: 25mm
 - Exit Pupil: 17mmH x 6mmV
 - Convergence: 7'10", 100% Overlap, TBR
 - Connection: Standard 15 Pin VGA
 - Refresh Rate: Flicker Free 120hz display rate
 - Input Frequency: 60 Hz to 120 Hz
 - Audio: Full Stereo
 - Weight: < 7 Ounces
 - Adjusts to Fit all Individuals
 - Power: Barrel connector
 - Cable Configuration: VGA / RCA Audio / Power
 - Power Supply: Power Cube
 - Controls: On/Off, Volume, OSD
 - LCD Contrast Ratio: Minimum 100 to 1
 - Compatible with nVidia-based graphics cards
 - On-Screen-Display: Adjusts Contrast, Brightness, Audio Balance, RGB Color and Horizontal Centering

2.2.3.3 Sensor Sub-Assembly

2.2.3.3.1 Inertiacube

- Degrees of Freedom 3 (Yaw, Pitch and Roll)
- Angular Range Full 360° - All Axes
- Maximum Angular Rate* 1200° per second
- Minimum Angular Rate* 0° per second
- Accuracy* 1° RMS at 25°C
- Angular Resolution* 0.01° RMS
- Serial Interface Update Rate 180 Hz
- Minimum Latency 2 ms for RS-232 (PC host OS dependent)
- Prediction up to 50 milliseconds
- Serial Rate 115.2 kbaud
- Ethernet w/ Windows Control Software
- Size 1.137 in x 0.960 in x 1.335 in
(28.89 mm x 24.38 mm x 33.91 mm)
- Weight 0.88 ounces (25.00 grams)
- Cable Length 15 ft. (4.572 m) - Max. 75 ft (22.86 m)
- Power 6 VDC, 100 milliamps via AC adapter
- Operating Temperature Range 0° to 50° C
- O/S Compatibility .dll for Windows 98/2k/NT/XP/CE
- .so for Linux and SGI IRIX
- libisense.dylib for Mac OS X
- Software Support SDK with full InterSense API
- Windows Control & Connectivity Software
- Optional Heading Calibration Software
- *Measurements with perceptual enhancement algorithm turned off (= 0)

- InterSense USB Update Rate Windows 98/2000 up to 150 Hz
- Windows XP 70 Hz
- Macintosh OS X 40 Hz
- USB Interface Minimum Latency 4 ms for USB direct (PC host OS dependent)
- Power Source Direct from Host USB Port
- USB Adapter Size 2.36 in x 1.38 in x 0.79 in
(60 mm x 35 mm x 20 mm)
- Cable Length 9.84 feet (3 meters)

2.2.3.3.2 Ascension Sensor Array

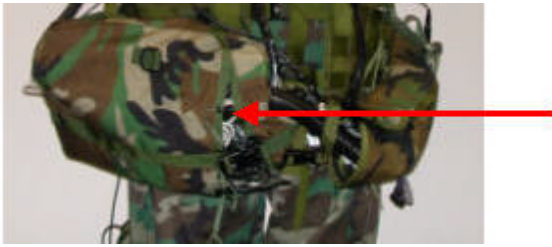

Figure 11 6-DOF Tracker Electronics Board

- Degrees of Freedom: 6 (Position and Orientation)
 - Translational range: 5 feet
 - Angular range: Unlimited: $\pm 180^\circ$ in azimuth & roll; $\pm 90^\circ$ in elevation.
 - *Static Accuracy –Position 0.3 inch RMS
 - *Static Accuracy – Orientation 1.3 degree RMS
 - Static Resolution Position: 0.5mm @ 30.5cm
 - Static Resolution Orientation: 0.1° @ 30.5cm
 - Update rate: 120 Hz one sensor; 60 Hz for each of two; 40 Hz for each of three, 30 Hz for each of four sensors
 - Outputs: X, Y, Z position, Euler angles, rotation matrix or quaternions.
 - Interface: RS-232
 - Software: Commands are compatible with existing Flock Bird and MotionStar products.
 - Format: Binary data records
 - Number of sensors/card: Up to four.
 - Sensor size: 1.3 inch X 1.1 inch X 0.8 inch with 6 feet of cable; sensor head weight: 1 ounce.
 - Electronics Unit: PCB. 14 inches long X 4.75 inches high X 1.25 inch thick. (max thickness in area of mezzanine pcb)
 - Transmitter: 1.75 inches X 1.75 inches X 2 inches; transmitter head weight: 6 ounces
 - Power: Rechargeable NiMH battery: 9.6V 3700mAH; 12 W:
Operating time: 2hours 50 minutes approx. Battery dimensions: 5.25 inches X 0.75 inches X 2.75 inches; 16.7 ounces
 - Environmental: 10 to 40° C, 95% non-condensing humidity.
- *Accuracy verified over range from 10 inches to 28.2 inches.

2. Power Sub-assembly

- Battery Chemistry: NiMH
- Nominal Voltage: 12V DC / 2.0 A



Figure 12 Sensor Battery Charger

2.2.3.4 Weapon Sub-Assembly

1. Logitech® Cordless Rumble Pad
 - Cordless 2.4 GHz Dual Analog Stick Logitech Wingman Game-pad
 - USB Connection
 - Eight-way D-Pad, 11 programmable buttons, Slide Throttle
 - Up to 7 Game pads can be used with no radio interference
 - 20 – Foot Range
 - Can Connect up to 8 game pads to a single PC
 - 50+ hours of game play provided by 4 AA Batteries
 - One-Year warranty
2. M4-A1 Carbine AirSoft Weapon

2.2.3.5 Soldier Control Unit (SCU)

1. Deskstick (Thumb pad)
 - Product Number: VP-6000
 - Cursor Control: Continuous 360-degree cursor control with speed proportional to applied force
 - Range: DeskStick includes 6 foot cable to serial 9-pin connector
 - Operation: A Microsoft compatible two-button mouse
 - System: IBM PC or compatible: Serial or PS/2 mouse port, DOS, Windows 3.X, 95, 98
 - Warranty: Limited lifetime from manufacturer

2.2.3.6 Leader Display Tablet PC

A COTS Tablet PC provides the leader display capability. The current system is based on the Hewlett Packard TC-1100 Tablet PC. It provides good 3D graphics capability for a tablet computer. The Leader display is loaded with and runs the General Dynamics S2Focus™ Software with the Mission Planning and Rehearsal extension as described in section 3.



Figure 13: Leader Tablet Display

2.2.4 Operating Systems

ASWETS software will run on either the Microsoft Windows 2000 or XP Professional™ Operating System.

2.3 Software Diagrams

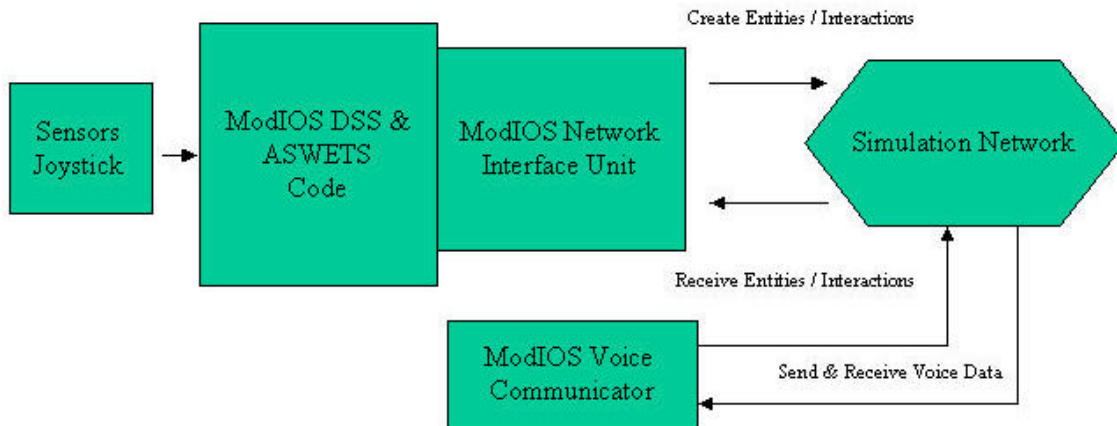

Figure 14: High Level DSS Software Block Diagram

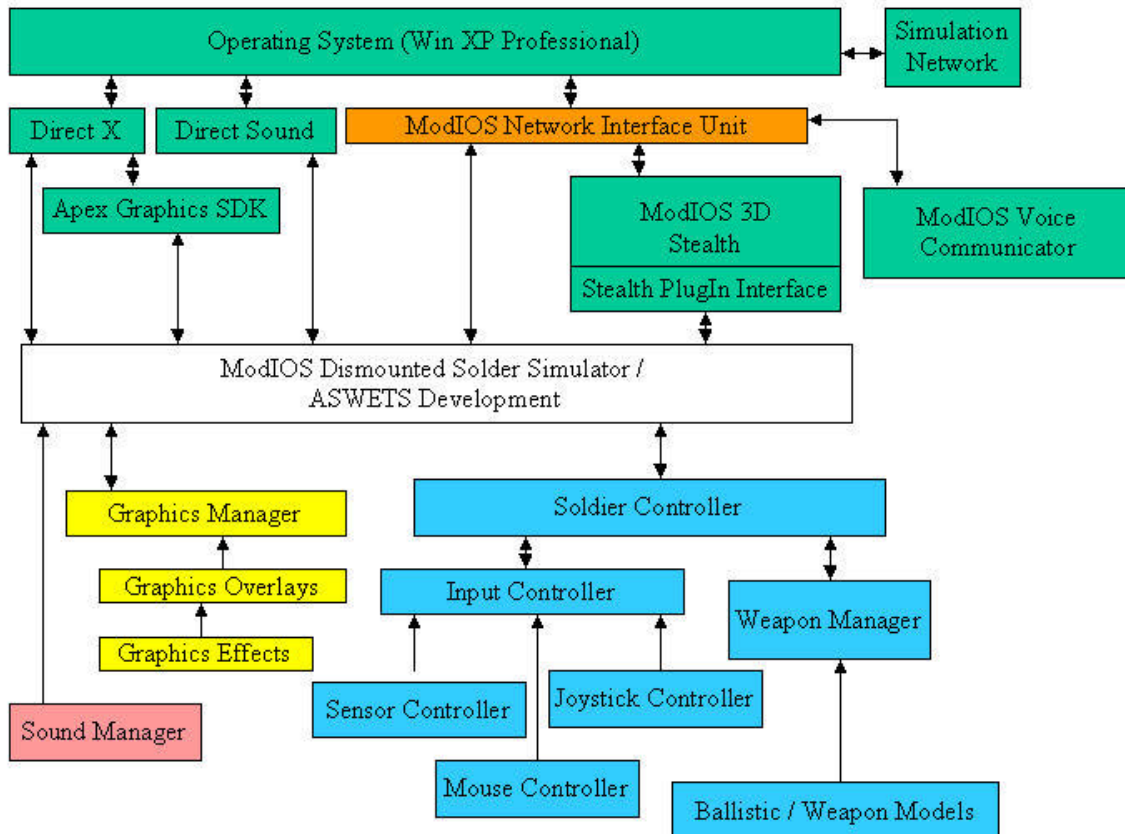

Figure 15: Detailed DSS Software Block Diagram

2.3.1 Software Components

The following is a description of the different software components that make up the ASWETS system and their function within the system:

ModIOS Network Interface Unit (NIU)

ModIOS[®] is one of the most comprehensive exercise management software packages commercially available. ModIOS provides the network interface to the simulation, exercise control functions, 2D and 3D views, recording and playback of simulated exercises, voice communications and after action review debriefs/reports. It is Commercial-off-the-shelf (COTS) software that works in conjunction with computer generated forces (CGF) packages and simulators.

The ModIOS Network Interface Unit connects multiple simulation applications to the DIS/HLA exercise using a common simulation API. It is Interoperable with ModSAF, OneSAF Test Bed (OTB), JCATS, STAGE, ITEMS, STRIVE and any IEEE DIS simulation

ModIOS® Network Interface Unit (NIU) connects multiple simulation applications to DIS/HLA exercises using a common API. The NIU offloads all DIS and HLA network processing.

- Client/Server architecture
- Supports DIS and HLA exercises utilizing plug-in network interface modules
- Offloads all DIS and HLA network processing from client to server
- Supports geocentric, geodetic, UTM, UTM Local and topocentric coordinate systems
- Manages virtually an unlimited number of DIS entities and HLA objects
- Implements all 9 DIS dead reckoning algorithms
- Performs automatic collision detection
- Performs automatic object attribute updates to the network
- Performs object smoothing
- Includes multiple multi-cast functionality for DIS
- Provides API interface for simulation management
- Allows for user configurable filtering
- Example client source code provided

ModIOS Voice Communicator (Voice over IP)

ModIOS® Voice Communicator allows the user to transmit and receive radio communication on a simulation network. Each instance of the ModIOS Voice Communicator has the capability to monitor up to 25 channels or simulated frequencies simultaneously, reproducing the radio traffic as it occurs across the network.

- Acts as an operator intercom
- Includes remote push to talk capability
- Allows for logging of voice notes
- Monitors radio communications
- Receives 25 frequencies and can simultaneously play back up to 10 channels/frequencies
- Transmits audio via push-to-talk or voice-on-transmit (VOX)
- Supports MuLaw, CVSD, and PCM audio modes
- Allows for user configuration during runtime via the graphical user interface (GUI)

- Interoperable with ASTi Radios

ModIOS 3D Stealth Viewer (STEALTH)

ModIOS 3D Stealth Viewer is a comprehensive visualization tool that presents a real-time, 3D perspective of the DIS/HLA battlefield. It allows the user to interact with and move about a 3D visual database without any interference or effect on the environment or the entities/objects involved in the DIS/HLA exercise. The 3D Stealth Viewer allows the user to virtually move through the DIS/HLA battlefield, view an entity/object or group of entities/objects, or attach to a specific entity/object.

The ASWETS project is currently using the ModIOS 3D Stealth Viewer with the APEX Graphics SDK. The APEX Graphics SDK is a 3rd Party Direct X based graphical rendering engine.

ModIOS Dismounted Soldier Simulator (DSS)

Dismounted Soldier Simulator (DSS) is a configurable set of hardware and software components enabling Individual Combatants (**IC's**) to participate in a simulation environment, while also offering the ability to control the simulation and capture event data for analysis and After Action Review (AAR).

1. Uses

- Dismounted Simulation Participant(s)
- Leader Training
- Wargaming
- Forward Observer Training
- Individual/Squad-level Mission Trainer
- Mission Rehearsal
- Simulation Based Acquisition (SBA)
- Virtual Reality Prototyping

2. Benefits

- Measuring the effects of prototype Soldier Technologies on mission performance
- Test, Verification and Validation of Soldier Platforms
- Low Cost Solution for Individual and Squad Level Mission Training Systems
- Leading Edge Technology Enabling Soldiers to be more Lethal and Less Vulnerable

3. Functional Description

The DSS provides the capability to add dismounted Individual Combatants (IC's) into a training system via Desktop and/or Immersive Simulators.

- **Desktop Simulator** – DSS software runs on a standard PC allowing low cost desktop IC's.
 - **Semi-Immersed Simulator** – DSS software runs on a standard PC with the video interfaced to low cost virtual reality glasses and a head tracker allowing low cost Semi-Immersed IC's.
 - **Immersive Simulator** – DSS software combined with immersive hardware provides virtual reality IC's with head, body and weapon tracking, head mounted displays and options including body worn processors for fully wireless virtual reality.
4. Other Features
- **Dynamic Urban Terrain** – Generates dynamic Wall Segments, Windows, Doors and other terrain objects where all participants on the distributed network are able to see changes that occur when these objects are opened, damaged or breached providing for more realistic simulations.
 - **ModIOS[®] Voice (licensed separately on Desktop and Semi-Immersed versions)** – ModIOS[®] Voice provides digital voice communications integrated into the simulation providing the ability for IC/IC and instructor/student interaction. The voice data is recorded via DIS for integration into the exercise analysis and AAR. Speech Recognition allows measurement and analysis of IC performance to include voice communications.
 - **Network Interface** –DIS and HLA simulation networking protocols provide IC's the ability to participate in distributed simulation exercises and interface to virtual and constructive simulations.
 - **Semi-Automated Forces (SAF)** – Virtual forces are provided by the SAF application. The system is also extensible to easily allow the use of third party SAF's including JCATS and OneSAF.
5. Applications
- **Forward Observer/Individual Mission Trainer** – DSS may be used for teaching individual skills such as procedure or part-task trainers. Desktop Simulators allow implementation of very low cost training systems. Immersive Simulators provide an advanced training experience via the virtual reality hardware.
 - **Leader/Squad-level Mission Trainer** – Squad-level training may be conducted by placing the Squad Leader in the Immersive Simulator with computer generated Squad members or role players participating on Desktop DSS's. Providing the Squad with intelligence data and situation reports, allows Mission Rehearsal with the ability to immediately analyze performance, including IC/IC voice communications, which are recorded and become part of the exercise analysis and After Action Review.
 - **Simulation Based Acquisition (SBA)** – DSS supports test, verification and validation prior to production and deployment of soldier systems with special emphasis on sensors, communications, lethality, survivability, mobility, and sustainability.

New solutions may be tested under varying conditions with repeatability and improvements made as needed, resulting in reduced cycle time and cost.

- **Virtual Reality Prototyping**– DSS provides a low cost method for rapid prototyping without having to bend metal, enabling measurement and understanding of the effects of next generation Soldier Technologies on mission performance.

Specifications

1. Dismounted Participant (Desktop)
 - Requires one Windows® 2000 or Windows® XP PC per Individual Combatant (IC)
 - High Performance PC Gaming Style User Interface using mouse and keyboard
 - Joystick/Gamepad Interface
 - PC and Joystick/Gamepad provided as a separate option
 - Multiple sensor and view modes including
 - Night Vision
 - Infrared Vision
 - Extendible to add new weapons, overlays, etc.
2. Dismounted Participant (Semi-Immersed)
 - Requires one Windows® 2000 or Windows® XP PC per Individual Combatant (IC)
 - Enhanced version of the Desktop configuration by replacing a conventional desktop monitor with virtual reality glasses and adding a head tracker to allow the user to change perspective by turning/moving their head
3. Dismounted Participant (Immersive)

Wireless Option

- Integrated vest with high performance PC providing processing, graphics, audio, sensor and 802.11G LAN
- Tracking system interfaced via 802.11G wireless LAN or optional self contained tracking
- Can also run Instructor Control software and SAF allowing for standalone operation
- Extensible to allow the addition of user I/O
- Multiple sensor and view modes including
 - Night and Infrared Vision, binocular and scope views
 - Tracking System
 - Head Position, Angle, Direction
 - Body Position (prone, kneeling, standing), Direction
 - Weapon Position, Angle, Direction
 - Additional Trackers may be added
 - Simulated Weapon

- Look, feel & weight similar to actual weapon
 - Trigger Switch (firing)
 - Magazine removal/insertion switch (reload)
 - Mini-Joystick to control motion
 - Configurable Switches to control initialization, view mode, zoom, sensor views & weapon type
 - Integrated headset and microphone for 3D Audio and voice Communications
 - Head Mounted Display (HMD) with dual LCD's
4. Audio
 - Windows® DirectSound 3D Audio
 5. Simulation Database
 - OpenFlight™ compliant
 6. ModIOS® Instructor Control Station (licensed separately on Desktop and Semi-Immersed versions)
 - Start, stop, freeze, position, orientation, weather and time of day control
 - Sensor control of individual DSS systems including multiple sensor views (IR, NV, Zoom, Scope)
 - Generate and report special events and messages
 - 2D/3D Visualization
 - Multiple Sensor and View modes
 - Extendible
 - Remotely controllable
 - Logger/Player
 - Records training exercises, experiments and tests
 - Plays back all recorded data
 - Marks events as they occur with a time stamp on an event timeline
 - Customizable
 - Exercise Analysis & After Action Review (AAR)
 - Integrated Event Tracking
 - Immediate Statistical Analysis
 - Integrated After Action Review Reports and Debriefs
 - Instructor Operator Station Controls
 - Report Generation Tool
 7. ModIOS® Voice (licensed separately on Desktop and Semi-Immersed versions)

Digital capture and playback via PC audio hardware

 - Simulates Radio Comms
 - Up to 10 simultaneous receive channels / frequencies
 - Push To Talk and VOX Capability
 - Instructor/Student Intercom
 - Comms captured for integration into AAR
 8. Network Interface
 - DIS / HLA protocol compliant
 9. Semi-Automated Forces (SAF)

- Provides virtual vehicles, troops and obstacles to the simulation exercise
- Extensible to incorporate third party and DOD SAF's including JCATS and OneSAF.

10. O/S Compatibility

- Windows® 2000 / XP® Professional

S2Focus™ Simulation Tool Suite

S2Focus™ is an all-encompassing Distributed Simulation Tool Suite for project development and run-time. S2Focus™ is object-oriented software specifically designed to run on the Windows® Operating System and specifically for High Level Architecture (HLA), with continuing support for Distributed Interactive Simulation (DIS) interoperability. Tool components are integrated in a cohesive and easy to use windowing environment that includes the following features:

- Network Interface Layer
- 2D and 3D Visualization (Viewer)
- Terrain Generation Option (Viewer Add-On)
- Data Capture, Analysis and Debrief (Recorder, Analyzer & AAR)
- Exercise Control (Manager)
- Mission Planning

S2Focus Tool Suite is run on the Tablet PC (or leader display) and provides the framework for the 3D Mission Planning and Rehearsal Plug-In for the 2D/3D Viewer component.

ASWETS Specific Enhancements

1. Contains wearable 6-DOF Tracker System allowing the combatant to walk around in an un-tethered system.
2. Increased Weapon Accuracy to aim / shoot weapon by looking down the 3D simulated weapon.
3. Soldier Control Unit for interfacing with mouse and headset / microphone.
4. Land Warrior camera view.
5. WUI – like Land Warrior control on weapon controller.
6. 3D Mission Planning and Rehearsal Plug-In for S2Focus.

2.3.2 Software Interfaces

The following are the internal interfaces to the 3rd party hardware:

1. Sensor Interface
 - a. Intertiacube Interface
 - i. Provides absolute orientation data. Sensor interface was established via it's provided SDK.

- ii. Connected to the Thermite via the USB port.
- b. Ascension Sensor Interface
 - i. Provides position and orientation data (6 degrees of freedom) for the head, weapon, and leg sensor. Sensor interface was established via it's provided SDK.
 - ii. Connected to the thermite by the COM / Serial port.
- 2. Weapon / Joystick Interface
 - a. Provides movement, weapon interaction (reload, change weapons, toggle displays).
 - b. Uses a standard joystick controller driver to interface with the hardware.
 - c. Connected to the thermite via the USB port.

2.3.3 User Interfaces

The primary viewing device for the ASWETS system is through the head mounted display (HMD). By looking through the HMD, the user will be able to look around in the virtual database, see on screen overlays and graphics, and interact with other combatants, simulators, and SAF entities provided they are compatible with the simulation protocol (DIS).

Though use of on the embedded stereo headphones the combatant is able to hear 3D environmental sound effects (weapon fire, explosions, engine noise). The combatant also has the capability of using radio comms by using the ModIOS Voice Communicator software. This software is a DIS compliant radio communication package that is interoperable with simulation radios such as the ASTi system. The combatant has the capability to transmit voice either by using VOX mode or using push to talk. The controls for volume and push to talk are located on the Soldier Control Unit (SCU), which is affixed to the vest.

The combatant controls his/her view of the virtual environment by turning their head and / or their bodies in the direction they wish to view. Sensors located on top of the HMD track the orientation, pitch, and roll of the combatant's head. In addition a leg sensor strapped to the lower thigh provides input on whether the user is standing, kneeling, or prone. A third sensor (6 DOF) attaches to the mock weapon to provide position and orientation on where the combatant has his/her weapon. A fourth sensor is available for future capabilities.

One moves in the virtual environment by using the joystick located on the mock weapon. This joystick allows the user to move forward, backward, and strafe left or right. To modify one's heading, one merely rotates his / her body in the direction he / she wishes to move in. In addition, the WUI provides several buttons to toggle on various graphical displays, fire weapon, change weapons, bore sight sensors, etc.

One fires rounds by pulling on the actual weapon trigger. To reload the simulated weapon one needs to release and reload the actual clip. The sensor (6 DOF) attached to the weapon provides orientation and positional updates. This allows the combatant to put the weapon out in front of him / her and see the simulated weapon in the scene.

2.3.4 Software Type

The ASWETS project's primary software was implemented by extending the ModIOS Dismounted Soldier System. The DSS software is proprietary, commercial-off-the-shelf (COTS) software that is provided under a restricted rights use license.

2.3.5 Programming Languages

The software used by the ASWETS project is written in the C++, DirectX, and OpenGL programming languages.

2.3.6 Information Classification

There are no requirements concerned with security and privacy for classified/unclassified data.

2.3.7 Licensing

The ASWETS project licensing is provided under a commercial limited-rights software license. The ModIOS Dismounted Soldier Simulator is licensed in a "node-lock" fashion and each copy is restricted to operate on a single host computer.

2.4 Using the ASWETS System

2.4.1 Starting the System

ASWETS is started by first turning on the Thermite computer and insuring that all cables (USB, power, video, etc) are securely fastened. System startup involves starting the ModIOS Network Interface Unit (NIU) and then starting the ModIOS 3D Stealth with ASWETS Plug-In.

2.4.1.1 Starting the ModIOS NIU

Double clicking on the ModIOS NIU Shortcut starts the ModIOS NIU. This shortcut can be accessed by selecting the Windows Start Button -> Programs

-> ModIOS 2.3 -> NIU DIS shortcut. The shortcut can also be found on the desktop in the ASWETS Project Shortcut folder.



Figure 16: ModIOS Niu Shortcut

The following console will appear indicating that the ModIOS Niu has been started.

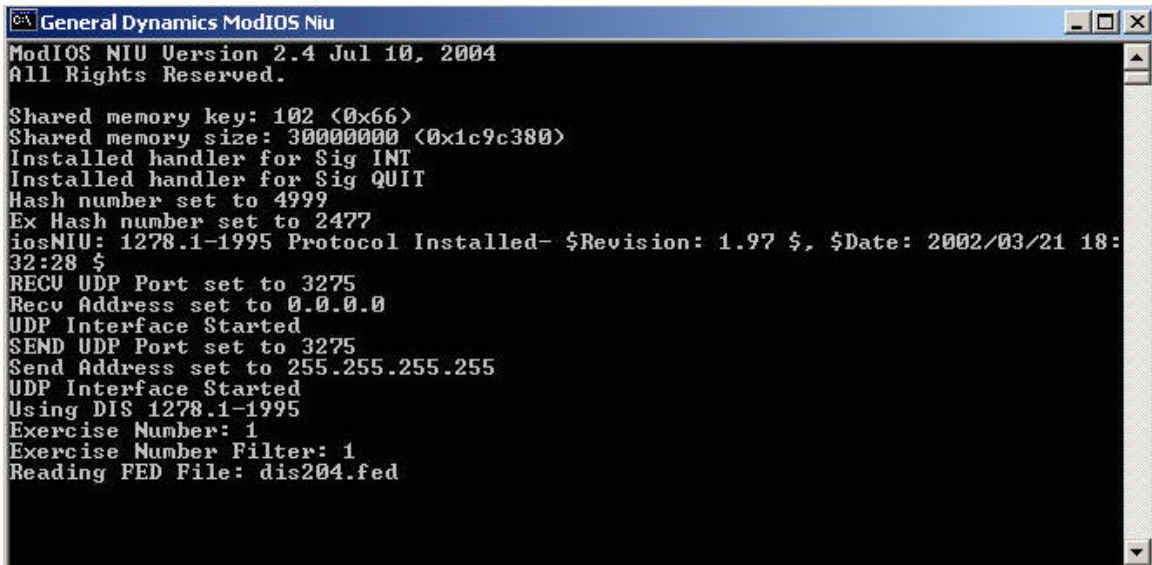

Figure 17: ModIOS NIU

2.4.1.2 Starting the ASWETS System

ASWETS may be started after the ModIOS NIU has been started. ASWETS is started by clicking on the ASWETS Program Shortcut located in the ASWETS Program Shortcut folder on the Windows Desktop.

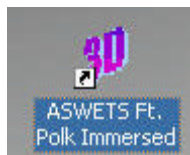

Figure 18: ASWETS Program Shortcut



Figure 19: ASWETS Program Window

2.4.2 Using the System

2.4.2.1 Graphical Display

The Graphical Display is used to visualize the virtual terrain and players, show soldier stance (standing, kneeling, prone, walking, running), and provide weapon and health information.



Figure 20: ASWETS Graphical Display

2.4.2.2 Bore sighting the System

ASWETS must be bore-sighted or calibrated prior to usage. Bore sighting initializes all the sensors with initial reference points and orientations so that the system tracks movement and orientation properly. The soldier should stand upright, hold the weapon as though he / she was going to fire the weapon and then press the bore-sight button on the joystick. Bore sighting is performed via “CTRL + B” or by pressing the bore-sight button on the mock weapon. See the mock weapon joystick buttons diagram for the button layout.

2.4.2.3 Moving Around in the Virtual Environment

Movement in the virtual environment is performed by using the joystick attached to the mock weapon and by orienting your body. Absolute orientation (e.g. heading) is read from the sensor on your vest. Thus one changes orientation by rotating your physical body. Forward, backward, strafe left, and strafe right operations are accomplished by using the direction joystick located on the mock weapon. Pressing up on the joystick pad causes movement in the current direction of the soldier. One can also change pitch and heading by rotating your head in the direction you wish to view. Forward movement occurs in the direction of the body, however you can also change heading and pitch offsets by looking upwards or downwards or to the left or the right.

2.4.2.4 Using the Weapon

2.4.2.4.1 Firing the Weapon

The user fires the weapon by pulling the trigger located on the mock weapon

2.4.2.4.2 Reloading the Weapon

The currently selected weapon is reloaded by releasing and reloading the clip on the mock weapon.

2.4.2.4.3 Button Controls

The mock weapon is used for moving around, sighting, and providing input to ASWETS. The weapon buttons are configurable, however a few of the default functions are depicted below.

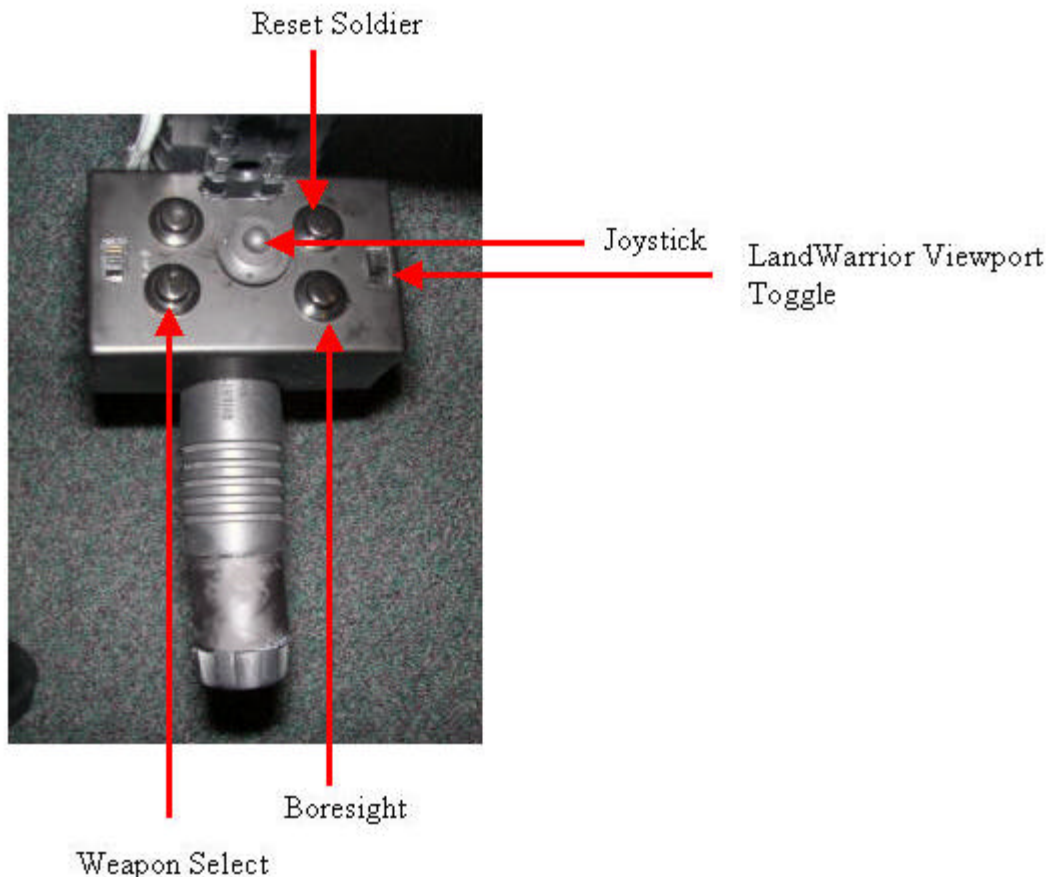

Figure 21: Joystick Button Configuration

- The Joystick is used to strafe and move forward and backwards.

- The Reset Soldier button is used to reconstitute the soldier in the event that the soldier was killed. Reconstituting also results in resetting the ammo counts and soldier location.
- The Land Warrior Viewport Toggle is used to enable / disable the 2nd Viewport used to represent the weapon view found on the Land Warrior System. Pressing the switch up and then down results in the toggle.
- The Bore sight button is used for bore sighting and aligning the sensors.
- The Weapons Select button is used to rotate through available weapons (e.g. M4, Smoke, Grenade Launcher).

2.4.2.5 Using the Land Warrior View

The Land Warrior View simulates the weapon's camera on the Land Warrior system. The Land Warrior View effectively represents where the weapon is looking. Thus one can use this feature to effectively look around corners with the weapon without making one susceptible to enemy fire.

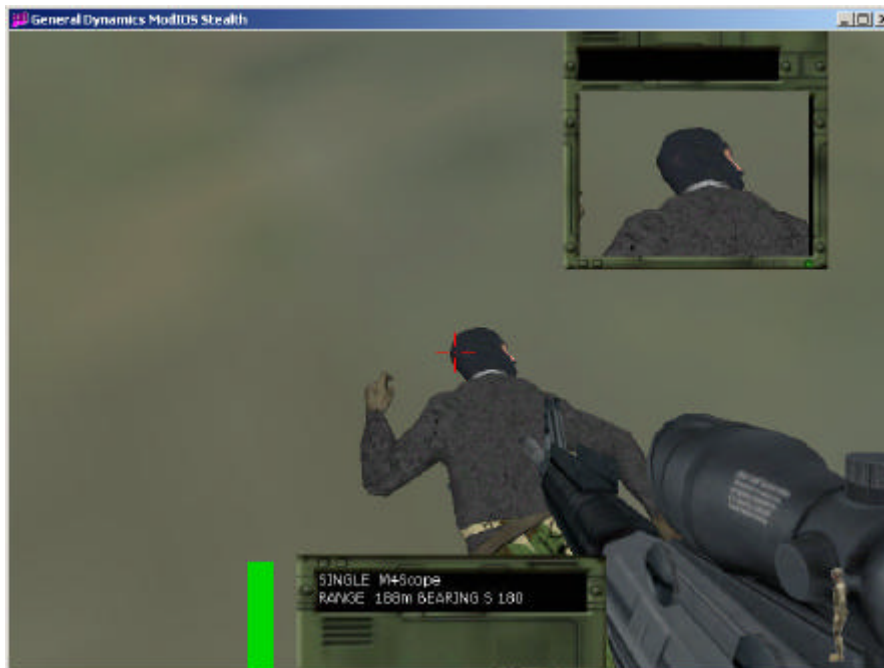

Figure 22: Simulated Land Warrior View

3 3D Mission Planning

3.1 Introduction

General Dynamics 3D Mission Planning Component was made possible by extending the Viewer Component Interface of the General Dynamics S2Focus Tool Suite. By using the S2Focus Viewer Components API, the 3D Mission Planning Component was able to re-use and take advantage of invaluable graphics and simulation APIs already present in the S2Focus product.

3.2 Software Components

3.2.1 Architecture

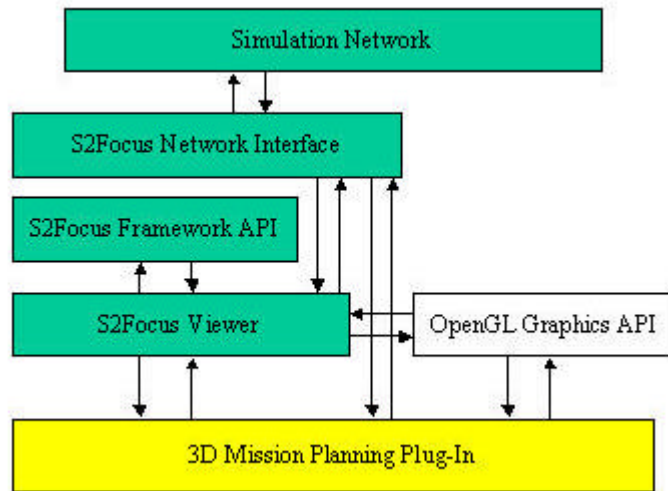

Figure 23: High Level Software Architecture

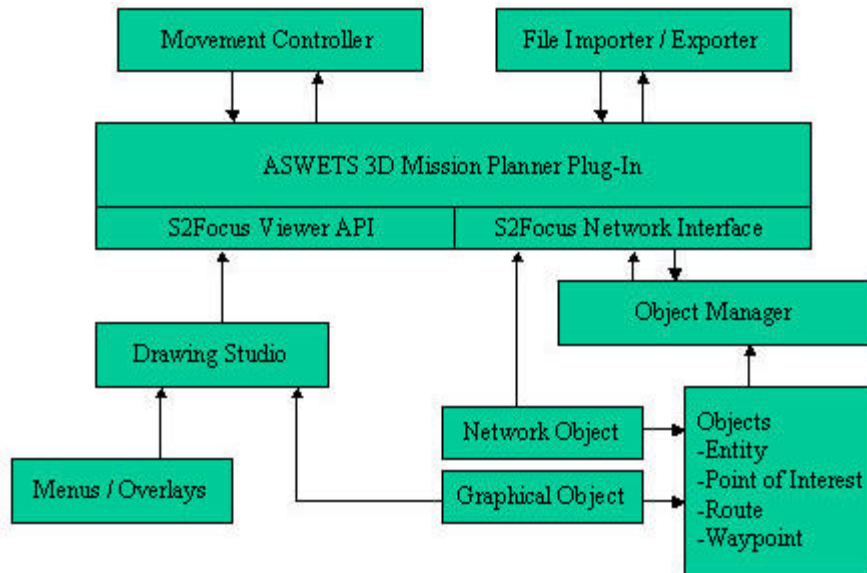

Figure 24: Detailed Level Software Architecture

Utilizing the Plug-In architecture of the S2Focus Component and S2Focus Network Interface, the 3D Mission Planning Plug-In is capable of utilizing graphics API calls (OpenFlight model support), network support (such as DIS and HLA simulation protocol support), and basic GUI support (mouse movement, click, etc).

3.2.2 Software Type

The 3D Mission Planner Plug-In's primary software was developed by extending the S2Focus Viewer Component. This software is proprietary, commercial-off-the-shelf (COTS) and is provided under a restricted rights use license.

3.2.3 Programming Languages

The software used by the 3D Mission Planner Plug-In project is written in the C++ and OpenGL programming languages.

3.2.4 Information Classification

There are no requirements concerned with security and privacy for classified/unclassified data.

3.2.5 Licensing

The 3D Mission Planner Plug-In project licensing is provided under a commercial limited-rights software license. S2Focus is licensed in a "node-lock" fashion and each copy is restricted to operate on a single host computer.

3.3 Using the 3D Mission Planner Plug-In

The 3D Mission Planner Plug-In requires a valid S2Focus Tool Suite License. In addition a high performance video card should be used for optimal performance. Additional information and requirements for S2Focus can be found in the S2Focus Help.chm file located in the installed S2Focus \ Mod \ Help directory.

3.3.1 Loading/Unloading the 3D Mission Planner Plug-in

To load the plug-in, first open a viewer document, either new or existing. From the Viewer menu select Configurations->Plug-Ins (or click the plug-ins icon on the viewer menu bar). You will now see the viewer plug-ins dialog. Unload any plug-ins, which may be loaded on the right, and select and load the "Viewer Mission Plug In" on the left.

Zoom into the area of the world that contains your 3D terrain and wait for it to load. Switch to 3D mode. From the camera pull down, select the Planner camera. By default this will place you at the origin of the database, this may not be desired if the database origin isn't within the bounds of the database. To fix a view position problem, if it occurs, switch to the hover camera press "r" to reset you to the middle of the database then switch to the free camera. By switching cameras after you are at your desired location the location used by the mission planner plug-in will be reset. You can now switch back to the Planner camera and will be positioned at the location of the last camera switch.

When the plug-in is loaded you must configure the Entity Id of the entities, which will be produced by this plug-in. To do so: open the plug-ins dialog as above and highlight the Mission Planner plug-in. When the plug-in is selected the properties button below will be enabled. Click the properties button, enter a unique Site and Host number and press "OK".

For later use you can save the document, *File->Save As*, this will keep your current plug-in location, orientation and site and host numbers.

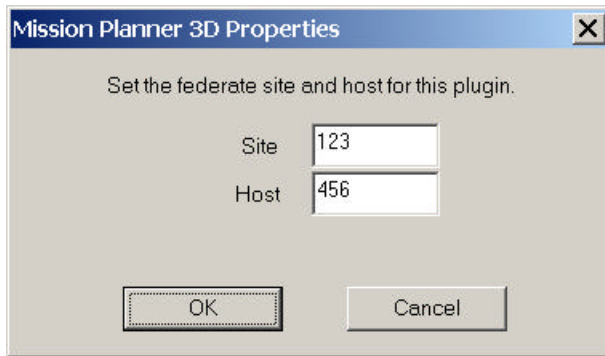

Figure 25: 3D Mission Planner Plug-In Properties

3.3.2 Movement and View Modes

There are two basic movement models. The first is Hover. When in Hover mode moving the mouse to the edge of the screen will cause your viewpoint to move in the corresponding direction. Clicking the left mouse button and moving the mouse will cause your viewpoint to rotate about your current position. The second major view mode is Fixed Point, this mode orbits around a single point. Moving the mouse with the left button clicked causes the view angle to change just like before but the view remains centered on the same point so your position will change. Moving the mouse to the screen borders moves your viewpoint left, right, and toward and away from the fixed point.

Switching between primary view modes is done using the icon in the upper left corner of the screen; the icon displays the currently active view mode. Clicking on the icon will switch you to the next view mode. The Icons are:



Figure 26: 3D Mission Planner Plug-In View Mode Icons

Your Movement speed can be adjusted by pressing the “[” and “]” keys on the keyboard. Be careful though, or you will move so fast that you will fly right off the database. If this happens use the information in the loading and unloading plug-ins section to reset your view position.

3.3.3 Creating Entities and Points of Interest

To create an entity use the right most menu bar. Left click on the object that you wish to create. The object will then appear on the terrain at the point beneath the mouse cursor. To rotate an entity use the scroll wheel, to place it use the right

mouse button. When an Entity or Point Of Interest is selected and able to be placed it has a yellow halo drawn around it for identification.



Figure 27: 3D Mission Planner Plug-In Create Menu



Figure 28: A selected Entity

3.3.4 Creating Routes and Waypoints

Routes are created by placing individual waypoints on the terrain. As the waypoints are placed on the terrain, a green line representing the route connects them. A waypoint is represented as a rotating orange flag. Like entities, waypoints are positioned by right clicking on the terrain. When selected they have a yellow halo for identification. To stop placing new waypoints for a route, click on the second icon (circle with a diagonal line) in the route menu.



Figure 29: Route Menu

3.3.5 Assigning Routes to Entities

Assigning a route to an entity is performed by creating a new route while that entity is still selected. With an entity selected click on the route menu item and right click on the terrain to place the first waypoint. The Entity will be placed along with the first waypoint and subsequent waypoints can then be added just as if you were creating a normal route. Stop adding to the route by clicking on the stop route menu item, just as before.

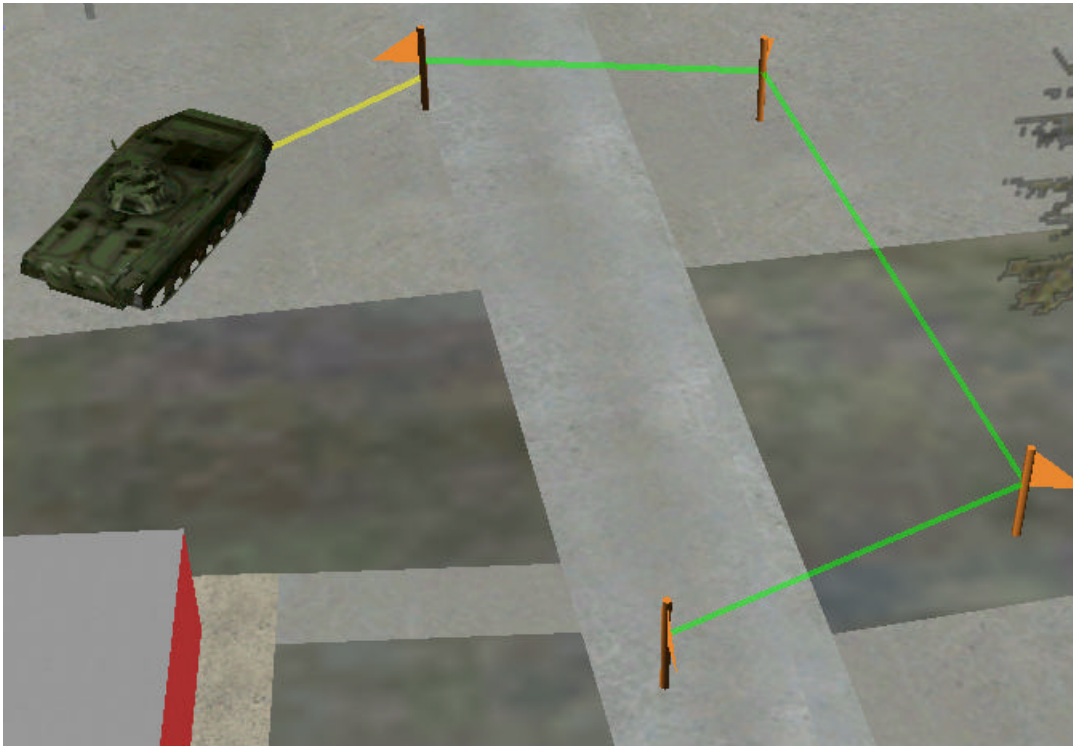

Figure 30: An Entity with an assigned route

3.3.6 Selecting and Moving Objects

Objects that have already been placed can be moved and rotated by right clicking next to them. This will cause them to be selected and display a yellow halo. They can then be manipulated just as when they were placed initially. Waypoints are a special case when selecting objects: because of the ability to follow a route waypoints are selected by right clicking as before but instead of being selected immediately a submenu is presented, when the new menu is displayed click select.

Be aware that right clicking to select an entity will select the closest entity, which may be behind your view. There is also a maximum range that an entity can be picked from, if you click too far away from the entity then nothing will be selected. When attempting to click on an object, distance measurements are calculated from the objects origin, which is typically at ground height. To be sure you are selecting the object you desire, click on the ground immediately in front of the object you wish to select.

3.3.7 Network and Remote Objects

When local objects are created a network object which represents your object is also created. This allows other people participating on the network to see what you are doing. Entities placed on the terrain will be seen by all other network participants in real-time. Newly created routes, waypoints, and points of interest (POI) will only be seen by those who have the Mission Planner Plug-in loaded.

Remote objects (except entities) are displayed with an orange route line or an orange halo. You are not able to select or modify remote objects, only the owner of an object may perform modifications.

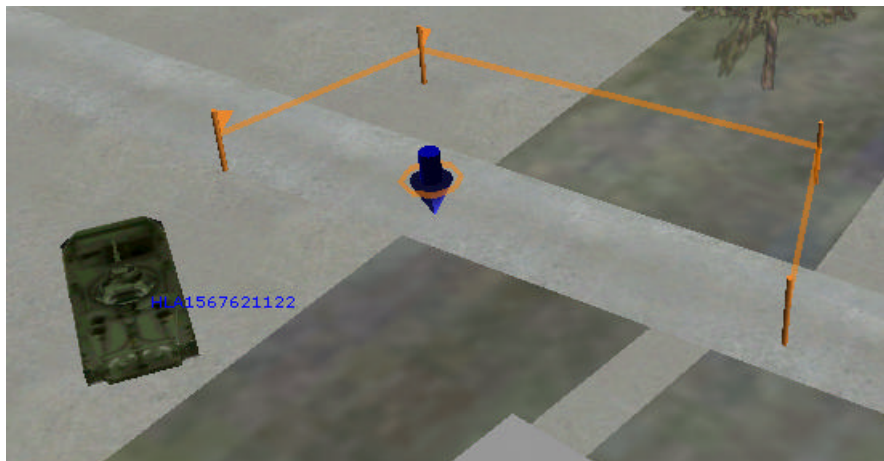

Figure 31: Remote Route, Entity, and Point of Interest

3.3.8 Following Routes

Following routes is done by right clicking on a waypoint and selecting follow from the popup menu. The view is now changed to route following. By clicking the left mouse button and moving the mouse the view angle can be changed. Moving the cursor to the top of the portion of the 3D window will move your viewpoint forward through the route, the bottom of the screen will move the viewpoint backwards through the route. Forward and backward are based only on the route direction, not on the view heading. When either end of the route is reached movement will stop. You will be able to travel in the opposite direction only. To return to a standard view mode click on the view menu in the upper right of the screen.

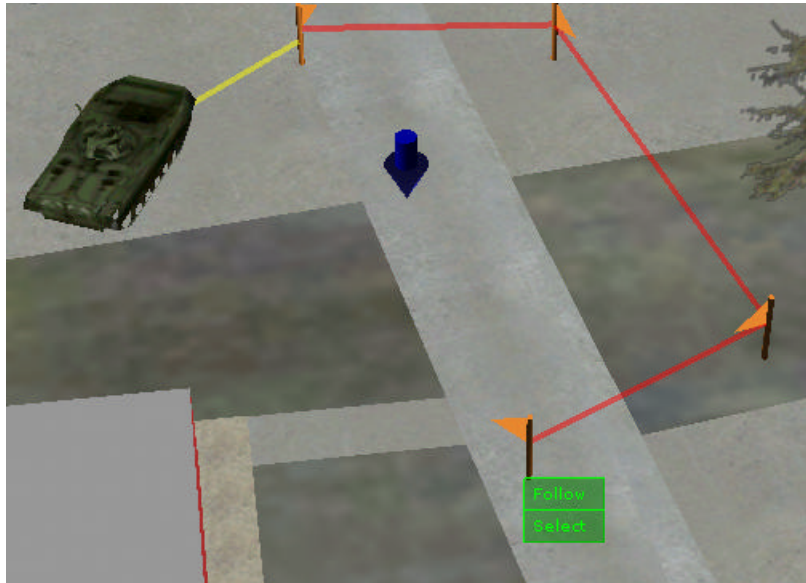

Figure 32: Follow Route popup menu

3.3.9 Follow the Leader

Each Mission Planner plug-in has the ability to ask other to follow it. Pressing the “F” key will send a follow command to any other Mission Planner plug-ins on the network. When this is done other viewpoints will move with yours and see exactly the same thing seen by your view. You can have them stop following you by pressing “G”. Anyone previously following you will now be free to move as they please. Pressing “F” then “G” is a good way to get everyone back to a common location.

If your mission planner is currently following another, and you don't wish for this, you may switch view modes using the view menu in the upper right of the screen this will switch you back to independent movement.

3.3.10 Saving/Restoring Mission Planner Files

S2Focus Mission Planner documents can be saved from the Mission Planner plug-in. To save a Mission Planner document press the "S"(save) key. You will be presented with a save dialog, save the file as a *.mpl file. The Mission Planner file is a skeleton file which may then be opened either by Mission Planner or in the future by the Mission Planner 3D plug-in. To open an existing Mission Planner file from within the Mission Planner 3D plug-in press the "O"(open) key, browse to and select the file you wish to open and press OK. The mission planner routes and entities will then be displayed in your 3D view.

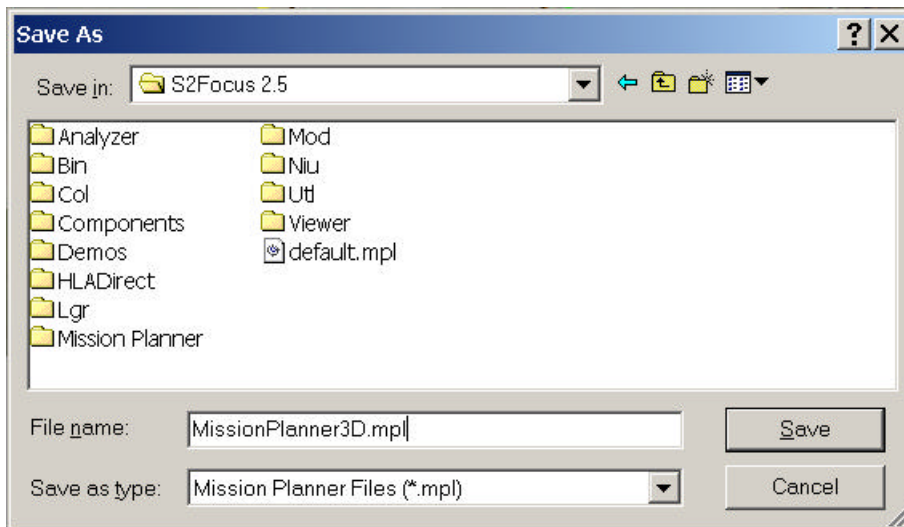

Figure 33: Saving a Mission Planner file

4 Appendix

4.1 Monthly Report Summary

4.1.1 April Status Report

4.1.1.1 Work Performed

- Software
 - Dismounted Soldier Simulator
 - Coded up performance enhancements with regards to intersection testing for multi-level line of sight tests. Improved overall frame rate by approximately 1 fps on the average
 - Coded up performance enhancements with regards to intersection testing used in 3D Recticle
 - Performed miscellaneous code enhancements to speed up performance and cut down processor usage
 - Started 2nd Viewport integration
 - Modified intersection test handling to allow easier traversal in the database and walking up / down stairs.
 - 3D Mission Planning
 - Held initial kickoff and planning meetings
 - Started investigating handheld displays/tablets to use as leader's planning interface. Needs to support at least 800x600 and touch or pen interface.
 - Started initial development
 - ▶ DSS / UFO Style movement camera completed in S2Focus Viewer Plug-In
 - ▶ Started loading 3D Models for dynamic placement
 - OneSAF
 - Requested OneSAF 2.0 from RDECOM
 - Started install and initial testing of OneSAF 2.0 on Linux (borrowed CD's from another project)
- Hardware
 - Thermite
 - Acquired Thermite Unit
 - Installed General Dynamics Dismounted Soldier Simulator and Network Interface
 - Ran initial tests with Dismounted Soldier Simulator
 - Mock Weapon
 - Ordered pack and pouches. Pack has arrived. Pouches should arrive in the next couple of weeks.
 - Ordered initial parts for mock weapons build. Materials should be arriving in the next couple of week

4.1.1.2 Findings and Issues

- Software

- Dismounted Soldier Simulator
 - Will need to continue performance increases to make database and rendering accommodate the usage of the slower processor and graphics capability of the Thermite.
 - Hardware
 - Thermite
 - Did not have wireless antenna, which prevented us from getting a strong signal with our Wireless router. – Received the antenna so this is no longer an issue.
 - Only has 1 USB connector that is active. This poses a problem since we require 4 USB devices (license dongle, usb wireless joystick, wireless keyboard, possible USB inertia tracker). With our previous system we used a USB hub that would be powered by both USB ports. Possible solution will be to run a USB hub powered by the external power outputs of the Thermite.
 - Still waiting on documentation on the Thermite and electric specifications.
 - Looking to see if we can get an 802.11g PC card for Thermite from Q3D.
 - Motion Trackers
 - Placed order with Ascension for wearable tracking system. Waiting for vendor to complete tracker implementation. Expected delivery date of mid-June. Testing with existing hardware for now.
 - Mock Weapon
 - Waiting for mock weapon and parts to arrive, currently on order.
 - Looking at emulating LWSI weapon user interface (WUI) and soldier control unit (SCU).

4.1.1.3 Description of Work Planned for Next Month

- Dismounted Soldier Simulator
 - Performance enhancements
 - 2nd Viewport / Land Warrior viewport
 - Integration with new Motion Trackers if delivered
 - Target Handoff Ability (Meeting planned for 5/6/04)
 - Continue testing / verification on Thermite with new Dismounted Soldier Simulator
 - Enhance Joystick movement
- 3D Mission Planning
 - Ability to draw waypoints
 - Initial menu functionality, texture loading, callbacks, orthographic overlays
 - Develop 3D Model framework, portable between ModIOS and S2Focus
 - Position and Rotate Objects in 3D space
 - Create and modify routes
 - Add object ,waypoint, route render callbacks and implementations

- Create network instances for all created objects
- Network interface for creating and modifying data interactions for routes, and points of interest

4.1.1.4 Specific Actions Needed from RDE Command STC

- Need to obtain release / non pre-production Thermite as soon as possible.
- Requested from Bruce Knerr to get a copy of DIVAARS to integration testing
- Waiting for official OneSAF 2.0 version.

4.1.2 May Status Report

4.1.2.1 Work Performed

- Software
 - Dismounted Soldier Simulator
 - Initial build of Land Warrior display renders second viewport
 - Able to attach viewport to entity as well as modify heading and pitch of secondary viewport.
 - Andrew Jarvis and Gary had meeting at RDECOM to discuss target handoff.
 - 3D Mission Planning
 - Created new camera movement model
 - Ability to laydown 4 different types of entities on the terrain
 - Contains clickable buttons overlays
 - Can draw waypoints with connector lines
 - OneSAF Test Bed
 - Installed OTB 2.0 on lab machine
 - Installed Ft. Polk CTDB and created simple scenario to use with DSS.
- Hardware
 - Thermite
 - Ran tests with Dismounted Soldier Simulator on newer version of Thermite. CG2 let us borrow their test unit for a few hours.
 - Mock Weapon
 - Received mock AirSOFT weapon
 - Started production / integration of controls into the mock weapon
 - Working with LW program to get WUI and SCU mockups, however they are under pressure to get production systems out the door.
 - Tracking System
 - Started Prototyping with existing Flock of Birds Tracker until wearable tracking system is received mid-June.
 - HMD
 - Ordered io-glasses HMD and Inertia Sensor along with strap to attach the HMD directly to the Helmet.

4.1.2.2 Findings and Issues

- Software
 - Dismounted Soldier Simulator
 - Will need to continue performance increases to make database and rendering accommodate the usage of the slower processor and graphics capability of the Thermite.
 - Land Warrior Viewport doesn't properly use the orientation of the attached entity
 - Still need to add configuration items to land warrior display
 - Land Warrior Display and current viewport must be looking in the same direction in order to see entities in 2nd viewport.
 - Started working on enhance weapon precision task.
- Hardware
 - Thermite
 - Still having to do initial tests on pre-production Thermite
 - Waiting for final Thermite with 512MB RAM and 2 USB ports.
 - Motion Trackers
 - Waiting for Ascension trackers (due June 18th, 2004). Prototyping with FOB system in the mean time.
 - Mock Weapon
 - Started creating joystick / weapon.
 - Looking at emulating LWSI weapon user interface (WUI) and soldier control unit (SCU).
- Ft. Polk Terrain Issues
 - Buildings now Black in S2Focus (VTREE)
 - Trees, Tower, and Light Pole.(VTREE)
 - Terrain Heights seem different from version receive in February.

4.1.2.3 Description of Work Planned for Next Month

- Dismounted Soldier Simulator
 - Performance enhancements
 - Integration with new Motion Trackers if delivered
 - Continue testing / verification on Thermite with new Dismounted Soldier Simulator
 - Enhance Joystick movement
 - Enhanced 3D character/soldier model.
- 3D Mission Planning
 - Create and modify routes
 - Add object, waypoint, route render callbacks and implementations
 - Create network instances for all created objects
 - Network interface for creating and modifying data interactions for routes, and points of interest
 - Looking to purchase high-end tablet (HP) or hand held display to provide 3D Planning platform and mockup CRIS for Squad leader. Need to discuss.

4.1.2.4 Specific Actions Needed from RDE Command STC

- Need to obtain release / non pre-production Thermite as soon as possible. Last report from Q3D was around June 14th.
- Requested from Bruce Knerr to get a copy of DIVAARS to integration testing (outstanding from April)
- Any updated scenarios/plans for event in July.
- GD has offered to provide our voice software for the event for embedded voice communications, but have not gotten a response.

4.1.3 June / July Status Report

4.1.3.1 Work Performed

- Software
 - Dismounted Soldier Simulator
 - Completed Land Warrior display to display where weapon is looking. Allows user to look around the corner with weapon.
 - Completed interface to new wearable sensor package and inertia cube.
 - Completed implementation of Soldier Tags
 - Completed mapping of US Helmet and AK47 and M4A1 models to soldiers,
 - Increased performance (fps) of 2D / 3D Drawing (soldier tags, health meter, weapon information overlay).
 - Increased performance (fps) of text drawing by combing text displays into a single string.
 - Made modifications to display correct stance (walking, running, crawling, etc) when receiving entities from AIS - SVS systems.
 - Integrated new civilian, opfor, and diguy models. This included new animations for dying, crawling, etc.
 - 3D Mission Planning
 - Create and modify routes
 - Add object, waypoint, route render callbacks and implementations
 - Create network instances for all created objects
 - Network interface for creating and modifying data interactions for routes, and points of interest
 - Looking to purchase high-end tablet (HP) or hand held display to provide 3D Planning platform and mockup CRIS for Squad leader. Need to discuss.
 - Assigning routes to entities
 - Export Scenario as S2Focus Mission Planner File
 - Follow Route Fly Through capability in S2Focus Viewer.
- Hardware
 - Thermite
 - Integrated into our soldier vest to prepare for Culminating event at Fort Benning.

- Mock Weapon and SCU
 - Completed mock weapon
 - Completed SCU (Soldier Control Unit) used for Push To Talk, Volume control, and Mouse control.
 - Tracking System
 - Integrated with new tracking system
 - Events
 - Attended EDTS STO Culminating Event at Ft. Benning
 - Provided ModIOS Voice Software, however not all vendors got it working at event.
 - Overall system performed well during all exercises. Most of the critical problems experienced by our system were hardware related, mainly batteries running out and cables getting disconnected.
 - Had issues with performance (update rate) of Ft. Polk Database on the Thermite. Ran between 10-15 Hz with around 40-45 entities.
 - Some soldiers preferred just having the reticle on the screen rather than the gun model, however some of them preferred seeing the weapon as well.

4.1.3.2 Findings and Issues

- Software
 - Dismounted Soldier Simulator
 - Had to make several code changes to support interoperability with SVS Standup machines at Fort Benning. The AIS – SVS machines would not send out the proper stance codes for their modeled entity. When the soldier would be walking it would send out a velocity and set the stance to standing, when it should send out the stance enumeration for walking. This also caused us to modify code to display the proper animations.
- Hardware
 - Thermite
 - Periodic problems with USB connection not detecting devices that are connected. Workaround is to reboot the Thermite.
 - Periodic problems with Thermite not outputting video to monitor on boot-up. Workaround is to reboot the Thermite.
 - Mock Weapon
 - Seems to drain battery power faster than expected.
- Ft. Polk Terrain Issues
 - Ft. Polk Database has some terrain problems, which results in DSS falling through building floor or jumping to roof. This was also an issue for some SVS systems as well.
 - Performance issues due to the size of the database and limited CPU/graphics performance of the Thermite computer.

4.1.3.3 Description of Work Planned for Next Month

- Dismounted Soldier Simulator
 - Sensor Weapon Accuracy improvements.

- Complete Target Handoff Task
- Complete Video Feed Task by switching among UAV/UGV vehicle views.
- 3D Mission Planning
 - Master / Slave Camera Following within DSS.
 - Improvements to user interface.
- Hardware
 - Investigate Weapon power drain issue
 - Clean up cables on harness
 - Purchase final Thermite for system delivery (still waiting for delivery schedule from Q3D and new performance upgrades). Remaining funding is tight. Need to discuss possibilities.
- Reports
 - Complete Architecture Document
 - Complete Final Report

4.1.3.4 Specific Actions Needed from RDE Command STC

- None