

ARMY RESEARCH LABORATORY



Hardening and Testing the Video Transmitter and Camera for the Shoulder-Fired Video Imager

by Michael L. Nair

ARL-TR-3353

November 2004

NOTICES

Disclaimers

The findings in this report are not to be construed as an official Department of the Army position unless so designated by other authorized documents.

Citation of manufacturer's or trade names does not constitute an official endorsement or approval of the use thereof.

DESTRUCTION NOTICE—Destroy this report when it is no longer needed. Do not return it to the originator.

Army Research Laboratory

Aberdeen Proving Ground, MD 21005-5069

ARL-TR-3353

November 2004

Hardening and Testing the Video Transmitter and Camera for the Shoulder-Fired Video Imager

Michael L. Nair

Weapons and Materials Research Directorate, ARL

REPORT DOCUMENTATION PAGE			<i>Form Approved OMB No. 0704-0188</i>		
Public reporting burden for this collection of information is estimated to average 1 hour per response, including the time for reviewing instructions, searching existing data sources, gathering and maintaining the data needed, and completing and reviewing the collection information. Send comments regarding this burden estimate or any other aspect of this collection of information, including suggestions for reducing the burden, to Department of Defense, Washington Headquarters Services, Directorate for Information Operations and Reports (0704-0188), 1215 Jefferson Davis Highway, Suite 1204, Arlington, VA 22202-4302. Respondents should be aware that notwithstanding any other provision of law, no person shall be subject to any penalty for failing to comply with a collection of information if it does not display a currently valid OMB control number.					
PLEASE DO NOT RETURN YOUR FORM TO THE ABOVE ADDRESS.					
1. REPORT DATE (DD-MM-YYYY) November 2004		2. REPORT TYPE Final		3. DATES COVERED (From - To) August 2003 to August 2004	
4. TITLE AND SUBTITLE Hardening and Testing the Video Transmitter and Camera for the Shoulder-Fired Video Imager			5a. CONTRACT NUMBER		
			5b. GRANT NUMBER		
			5c. PROGRAM ELEMENT NUMBER		
6. AUTHOR(S) Michael L. Nair (ARL)			5d. PROJECT NUMBER 1L162318H80		
			5e. TASK NUMBER		
			5f. WORK UNIT NUMBER		
7. PERFORMING ORGANIZATION NAME(S) AND ADDRESS(ES) U.S. Army Research Laboratory Weapons and Materials Research Directorate Aberdeen Proving Ground, MD 21005-5069			8. PERFORMING ORGANIZATION REPORT NUMBER ARL-TR-3353		
9. SPONSORING/MONITORING AGENCY NAME(S) AND ADDRESS(ES)			10. SPONSOR/MONITOR'S ACRONYM(S)		
			11. SPONSOR/MONITOR'S REPORT NUMBER(S)		
12. DISTRIBUTION/AVAILABILITY STATEMENT Approved for public release; distribution is unlimited.					
13. SUPPLEMENTARY NOTES					
14. ABSTRACT In support of the U.S. Army Research Laboratory's effort to develop and test a shoulder-fired video imager, the Southern California Microwave video nano-transmitter (VNTX) and Supercircuits PC182XS and PC72XS cameras were hardened (i.e., made to withstand shocks as great as 8000 g's) and shock tested. The components were tested at an acceleration that exceeds the maximum acceleration to be seen during the video imager tests on a bunker defeat munition. Shock testing revealed that filling the case of the transmitter with glass beads enabled it to sufficiently support the electronic components and allow a shock level of 8085 g's with no adverse effects. The PC182XS camera survived an equal shock level in a dedicated shock fixture but failed at a similar shock level when mounted in the imager round. The PC72XS survived shock at 7347 g's after replacement of the standard crystal oscillator with a surface-mounted crystal. Both the VNTX transmitter and PC72XS camera have been sufficiently prepared and tested to allow for use on the shoulder-fired video imager project. Further work can be done to qualify these two components for higher acceleration gun launches if desired.					
15. SUBJECT TERMS camera; hardening; shock testing; shoulder-fired video imager; transmitter					
16. SECURITY CLASSIFICATION OF:			17. LIMITATION OF ABSTRACT UL	18. NUMBER OF PAGES 40	19a. NAME OF RESPONSIBLE PERSON Michael L. Nair
a. REPORT UNCLASSIFIED	b. ABSTRACT UNCLASSIFIED	c. THIS PAGE UNCLASSIFIED			19b. TELEPHONE NUMBER (Include area code) 410-306-1051

Contents

List of Figures	iv
List of Tables	iv
Acknowledgments	v
1. Introduction	1
2. Components	2
3. Fixture and Part Design	4
4. Test Criteria	7
5. Experimental Procedures	8
6. Conclusion	18
7. References	19
Appendix A. Mechanical Drawings	21
Distribution List	32

List of Figures

Figure 1. VNTX transmitter.....	2
Figure 2. PC182XS camera.....	3
Figure 3. PC72XS camera.....	3
Figure 4. Camera shock figure, bottom plate.....	4
Figure 5. Camera mounted in shock fixture.....	5
Figure 6. Transmitter shock mount.....	5
Figure 7. The PC182XS camera mounted in the camera mounting plate and mounting box.....	6
Figure 8. Solid model showing the camera installed in the imager warhead.	6
Figure 9. BDM nominal acceleration.....	7
Figure 10. Southern California Microwave VNTX transmitter.....	9
Figure 11. Encapsulated camera showing the RTC sealant around the CCD.....	10
Figure 12. Camera fixture mounted to MTS shock table.....	10
Figure 13. Imager round mounted to shock table.	11
Figure 14. Recorded shock pulse during test of video imager.....	12
Figure 15. Displacement graph of the camera mounting plate from FEA.....	13
Figure 16. Displacement graph of the mounting box from FEA.....	14
Figure 17. PC72XS camera circuit board with Statek crystal.	15
Figure 18. Displacement of revised mounting box.....	16
Figure 19. Displacement of the camera mounting box in dynamic analysis.	17
Figure 20. Pre-shock video image.	18
Figure 21. Post-shock video image.....	18

List of Tables

Table 1. VNTX series transmitter specifications.....	2
Table 2. Supercircuits PC182XS specifications.	3
Table 3. Supercircuits PC72XS specifications.	4

Acknowledgments

The author would like to thank Jamie King of Dynamic Science, Inc. (DSI), for his invaluable assistance with soldering and help with the spectrum analyzer and Robert Wert of the Oak Ridge Institute for Science and Education, Tennessee, for his help in evaluating the performance of the transmitter. Special thanks to Keith Dougherty of the U.S. Army Research Laboratory (ARL) machine shop and Ron Wayne of DSI for machining the parts and fixtures used in these experiments. John Condon of ARL is especially appreciated for sharing his experience with the hardening of cameras and transmitters from previous projects. John Connor of Talley Defense Systems is thanked for providing needed information about the performance of the bunker-defeating munition.

INTENTIONALLY LEFT BLANK

1. Introduction

The U.S. Army Research Laboratory (ARL) has begun a mission program to build and test a shoulder-fired munition that carries a video camera and transmitter to test the feasibility of such a system for real-time reconnaissance imagery for use by Soldiers deployed in the field. The bunker-defeating munition (BDM), manufactured by Talley Defense Systems¹, was selected as the baseline weapon to be modified for use with the test because of its flight characteristics and availability. The BDM is a shoulder-fired recoilless rifle that is currently fielded by the U.S. Army. At launch, the BDM round experiences a maximum acceleration of approximately 6800 g's. To survive the acceleration, a transmitter and camera must be shock-hardened and tested to ensure that the imager round will function as desired during live fire testing.

The transmitter selected for the shoulder-fired video imager is the Southern California Microwave² video nano-transmitter (VNTX) series, which is used in ARL's silent operating aerial reconnaissance (SOAR) program. Despite its use in the SOAR program, this transmitter has not been tested for shock survivability. This report details the process of "hardening" the transmitter (i.e., making it to withstand shocks as great as 8000 g's), shock testing the transmitter to various levels, and then testing the transmitter to ensure that it was still functional. Testing showed that the hardened transmitter is able to withstand shock loads as great as 8085 g's without failure. Two cameras, both from Supercircuits³, were also tested during this work. Also detailed here is the hardening, shock testing, and evaluation of the two cameras. The PC182XS camera was filled with encapsulation material and shock tested. When mounted in the video imaging round, the camera failed at a shock level of 7532 g's. Because of this failure, finite element analysis (FEA) tools were used to try to determine the cause of the failure and ways to redesign the associated parts to ensure survivability of the camera. A second camera, the PC72XS, was hardened by replacement of the can-type crystal oscillator with a surface mount crystal and encapsulation of the camera. With the redesigned camera mounts, the hardened PC72XS camera in the imager round survived shock testing to 7347 g's.

Testing indicates that the efforts to harden the camera and transmitter were successful and that the components will function properly following launch with the BDM rocket motor. The hardening and testing of the transmitter can also be applied to the SOAR program. Current work on the SOAR vehicle includes launch testing in a variety of manners in which the transmitter can be used without failure.

¹Talley Defense Systems, P.O. Box 34299, Mesa, AZ 85277-4299.

²Southern California Microwave, 2732 Via Orange Way, Suite E, Spring Valley, CA 91978.

³Supercircuits, Inc., One Supercircuits Plaza, Liberty Hill, TX 78642.

2. Components

The transmitter selected for the imager is the VNTX series, shown in figure 1, manufactured by Southern California Microwave for use in law enforcement. This transmitter is used by Aerovironment⁴ in ARL's SOAR unmanned aerial vehicle (UAV). The transmitter was built to the specifications given by Aerovironment for the SOAR UAV. See table 1 for the specifications of the transmitter.

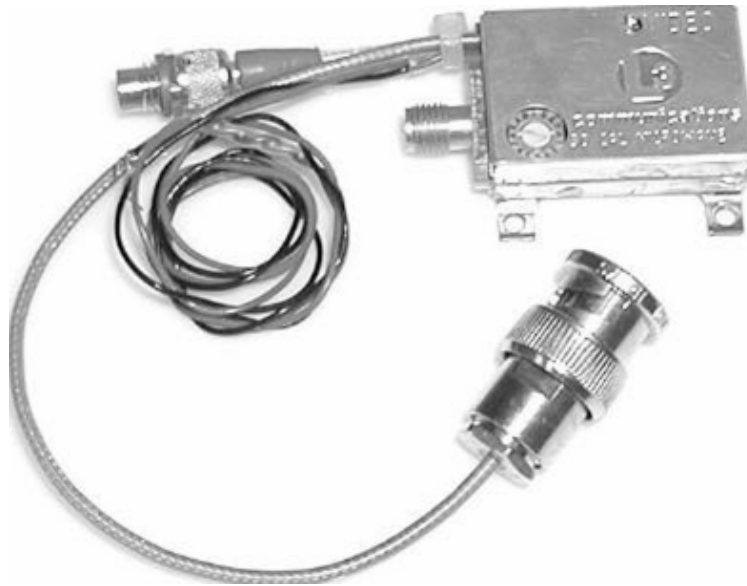

Figure 1. VNTX transmitter.

Table 1. VNTX series transmitter specifications.

VNTX Transmitter Specifications	
Frequency	1710 to 1850 MHz
Output Power	250 mW
Input Voltage	+9 to +16 volts direct current (VDC)
Typical Current Draw	110 mA
Subcarrier Frequency	7.5 MHz, transistor-transistor logic modulation
Subcarrier frequency Response	DC – 20 KHz
Temperature (Operating)	-20 to +70 °C base plate
Size	0.880 in. x 1.260 in. x 0.37 in. (0.41 cu in.)
Weight	1.27 ounces
RF Connector	Subminiature version A (SMA) female
Power Connector	Flying Leads
Video Connector	BNC* male on 12 inches of RG178
Audio Connector	Microtech 3-pin DR-3S-3

*BNC, which is not an acronym, is a connector (usually on a hub) that accommodates thin coaxial cable.

⁴ Aerovironment, Inc., 825 S. Myrtle Dr., Monrovia, CA 91016.

The camera intended for use is the Supercircuits PC182XS. This camera uses Sony's new Ex-View charged-coupled device (CCD) chip set which allows for low light visibility and high resolution. The camera uses a 3.6-mm lens and includes an electronic shutter that can vary the exposure from 1/60 to 1/100,000 second. The camera and its specifications are shown in figure 2 and table 2.



Figure 2. PC182XS camera.

Table 2. Supercircuits PC182XS specifications.

Light Rating	0.0003 lux
Pixels	411,988
Resolution	600 lines
Input Voltage	12 VDC
Current Draw	100 mA
Size	0.98 x 0.98 x 1.2 inches
Video Format	National Television Standards Committee (NTSC)

Because of the failure of the camera during shock tests, as detailed in the following sections, a second camera was selected and tested. The Supercircuits PC72XS camera, shown in figure 3, was successfully used by John Condon of ARL in a separate gun-launched application (Condon, McLaughlin, & Mitchell, 2001). For this application, the 4.5-mm micro-lens model was used. The PC72XS camera specifications are listed in table 3.



Figure 3. PC72XS camera.

Table 3. Supercircuits PC72XS specifications.

Light Rating	0.05 lux
Resolution	420 lines
Input Voltage	9 to 15 VDC
Current Draw	100 mA
Size	0.984 x 0.984 x 1.112 inches
Video Format	NTSC

3. Fixture and Part Design

Two fixtures were produced for testing the camera and transmitter. The fixtures were made from AL 7075-T6. The first fixture is made of two parts that clamp the camera between them. The bottom plate, shown in figure 4, has a pocket cut to hold the camera in the vertical position so that the shock axis is along the axis of the camera lens. A deep groove, which acts as a wire tray for the camera leads, extends from the pocket to the edge of the base. The four holes immediately around the pocket are 10-24⁵ tapped holes used to secure the top piece to the bottom plate. A 10-24 tapped hole permits mounting of an accelerometer for measuring the shock pulse during testing. The other four holes are for mounting the fixture to the shock table.

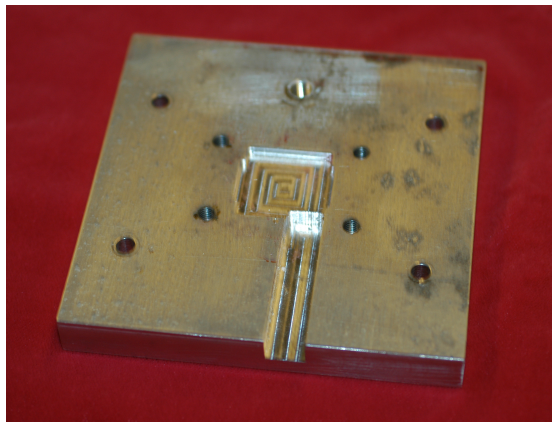

Figure 4. Camera shock figure, bottom plate.

The top piece is a plate with a clearance hole for the lens and four holes for mounting the top piece to the bottom plate. The two parts were held together with four 10-32 cap screws, as shown in figure 5.

The second fixture, shown in figure 6, is an L-shaped piece used for shock testing the transmitter. Two separate hole patterns permit mounting the transmitter so that the long axis of the transmitter is either horizontal or vertical. The transmitter is mounted to the fixture with four 2-56 machine screws. The bottom side of the fixture has a 10-24 threaded hole for the accelerometer as well as

⁵10-24 indicates a gauge size of 10 with 24 threads per inch.

four clearance holes for mounting the fixture to the shock table. The extra holes in the upright part of the fixture are for shock testing an antenna splitter used in the imager.

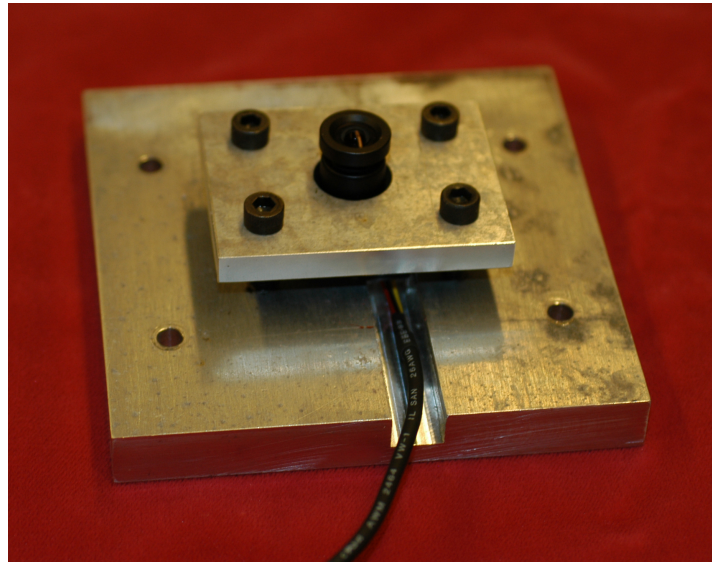

Figure 5. Camera mounted in shock fixture.

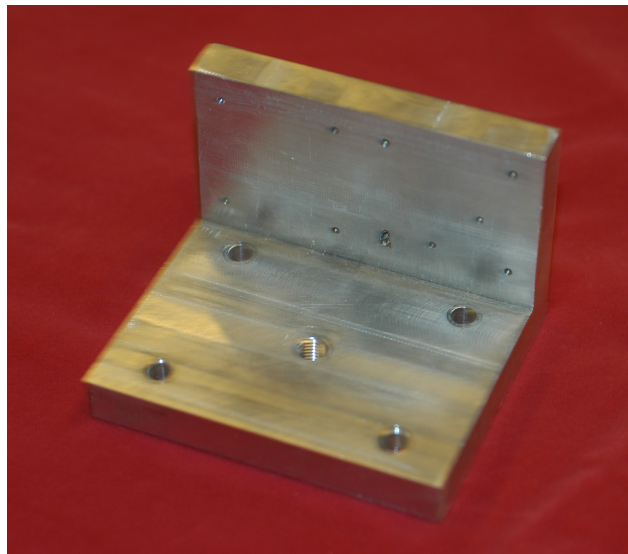

Figure 6. Transmitter shock mount.

During the evaluation of the transmitter and camera, four of the imager round bodies were manufactured at the ARL machine shop. Five camera mounting plates and five camera mounting boxes designed for the PC182XS camera were completed at approximately the same time. After completion of these parts, they were used to test the camera while installed in the imager round. When mounted in the round, the camera is held by clamps between the camera mounting plate and the mounting box, much like it is in the shock fixture. The clamping force is

applied to the camera immediately around the protrusion for the lens. The PC182XS camera mounted to the camera mounting plate and mounting box are shown in figure 7.

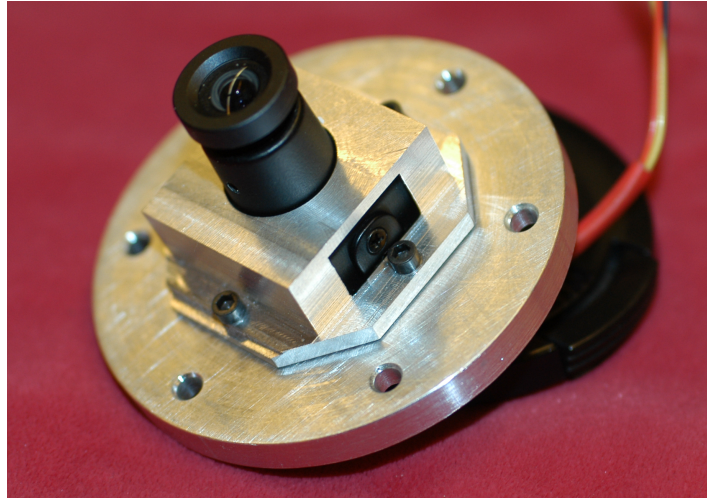

Figure 7. The PC182XS camera mounted in the camera mounting plate and mounting box.

After we decided to use the PC72XS camera, the camera mounting plate and mounting box were redesigned to accommodate the geometrical differences in cameras. Instead of having a clearance hole in the mounting box, a pocket was milled through the mounting box to secure the camera around the exterior of the small step exterior to the lens protrusion. Only two sets of the revised parts were produced because two of the rounds are mass simulators and do not require functioning cameras. Figure 8 shows the solid model of the round with the PC72XS camera, revised camera mounting plate, and mounting box installed.

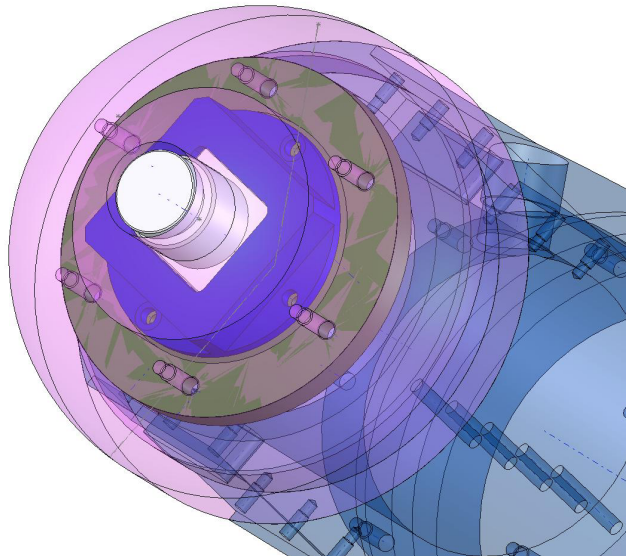

Figure 8. Solid model showing the camera installed in the imager warhead.

4. Test Criteria

The acceleration data for the BDM were provided by their manufacturer, Talley Defense Systems. Figure 9 shows the time history of the acceleration of the standard BDM.

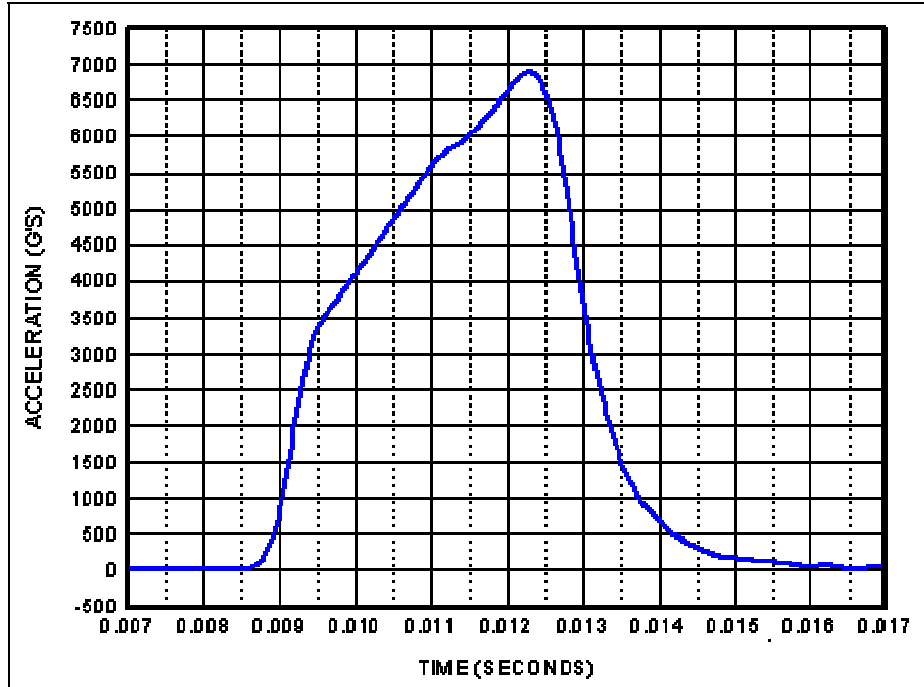

Figure 9. BDM nominal acceleration.

Since the imager warhead is heavier than the standard BDM warhead, the peak acceleration experienced by the components should be lower than the 6800 g's shown in figure 9. With the basic formula for force

$$F = ma$$

in which F is the force, m is the mass, and a is the acceleration, an estimate of the acceleration load can be calculated. The mass of the standard BDM mock warhead is 1745 grams. The replacement warhead is approximately 2050 grams, according to the solid model. By using the peak acceleration shown in the graph, we calculated the maximum force to be approximately 12,040 newtons. With that same force, the maximum acceleration experienced by the imager warhead should be approximately 5870 g's. Based on these numbers, it can be assumed that the 7000-g shock test will be sufficient to demonstrate survivability of the components in the launch environment.

5. Experimental Procedures

To harden the VNTX transmitter, it was planned to fill the interior of the transmitter with STYCAST⁶ encapsulation in order to provide the structural support needed for the components to survive launch. Before proceeding with this plan, we contacted the manufacturer of the transmitter, Southern California Microwave, and they reported that the use of encapsulation would have a high likelihood of de-tuning some of the components, thus resulting in a malfunction of the transmitter. This effect has been seen in unsealed inductors and capacitors during other projects at ARL. Since the encapsulation surrounds the components, the dielectric constant can be altered and the broadcast frequency of the transmitter potentially altered. To prevent this problem, glass beads were chosen to fill the transmitter case instead of the STYCAST encapsulation material. Experience has shown that glass beads can help electronic components survive lower acceleration environments without negative effects on the functionality of the components.

To verify that the transmitter was built to the specifications required, the transmitter was taken to California where it was tested with the Aerovironment ground control unit (GCU) to ensure that the unit was able to transmit the video image to the GCU. After the transmitter was returned to ARL, it was tested on a spectrum analyzer. The transmitter power at the center frequency of 1787 MHz was measured at 24.57 dBm with a 12-volt DC input. During testing, the transmitter output was attached to the spectrum analyzer with a 50-ohm load. At steady state, the transmitter draws 92 mA. Before the transmitter was filled with glass beads, several openings in the transmitter case were sealed with Dow Corning⁷ Silastic⁸ 734 room temperature vulcanizing (RTV) self-leveling adhesive sealant. The end of the transmitter case opposite the SMA connector was un-soldered to unfold the flaps. The glass beads available for use were No. 8 class 5A Microbeads⁹. The Microbeads measure 270 microns in diameter and are composed of soda lime glass. The glass beads were poured in the transmitter and as the case was filled, it was shaken to ensure that the glass was filling all open voids. After the case was entirely filled and soldered closed, the transmitter was tested again on the spectrum analyzer and the power transmitted was 24.58 dBm at 1787 MHz with the same power input.

The transmitter was mounted to the transmitter shock fixture oriented with the long axis of the transmitter in the vertical direction. The fixture was mounted to an MTS¹⁰ shock test system and subjected to an 8085-g acceleration as measured by an accelerometer mounted to the shock fixture. The transmitter was un-powered during the shock test. To ensure that the transmitter

⁶STYCAST[™], which is not an acronym, is a trademark of Emerson & Cuming.

⁷Dow Corning[®] is a registered trademark of Dow Corning Corporation, Midland MI 48606-0994.

⁸Silastic[®] is a registered trademark of Dow Corning Corporation, Midland MI 48606-0994.

⁹Microbeads[®] is a registered trademark of Cataphote, Inc., P.O. Box 2369, Jackson, MS 39225-2369.

¹⁰Not an acronym; MTS Systems Corporation, 1400 Technology Dr., Eden Prairie, MN 55344-2290.

was functional, it was again taken to Aerovironment's facility where it was successfully tested with the GCU. The test showed that the transmitter survived the expected launch acceleration without failure. The second transmitter was filled with glass beads according to the same process just described; however, it malfunctioned after the glass beads were inserted and the case was soldered. Testing showed that the center frequency was now at approximately 1550 MHz. After the transmitter case was opened (see figure 10), no obvious causes of the problem were seen and the unit was returned to Southern California Microwave for investigation. Southern California Microwave reported that several components were disconnected from the circuit board, which was likely caused by the heat from the case being un-soldered. Southern California Microwave repaired the unit and returned it with the transmitter case open, which allowed for easy filling of the case with the glass beads. After we re-soldered the case, the unit was retested on the spectrum analyzer and the center frequency was measured at 1787 MHz.

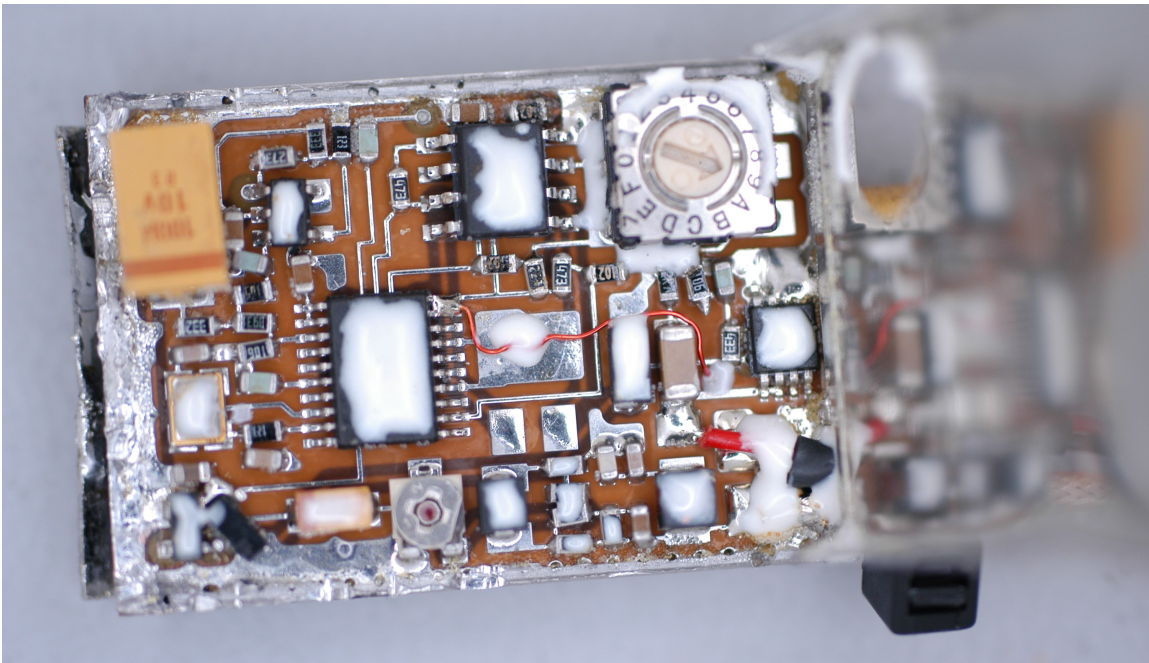

Figure 10. Southern California Microwave VNTX transmitter.

To survive the acceleration of gun launch, the camera was modified to prevent failure. To harden the camera, the PC182XS camera was disassembled. The camera is composed of four sections: the lens assembly, the camera body, the rear cover, and the circuit board. A bead of Dow Corning Silastic 734 RTV self-leveling adhesive sealant was laid around the edge of the CCD on the circuit board to form a seal with the camera body and prevent the CCD from being covered by the encapsulation material. Four holes were drilled in both the camera body and the rear cover with a No. 45 drill bit to allow for filling the case with encapsulation. The camera was re-assembled and then filled with Emerson & Cuming¹¹ STYCAST 1090SI encapsulation

¹¹Emerson & Cuming, 46 Manning Rd., Billerica, MA 01821-3916.

mixed with LV23 catalyst in a 100:25.4 ratio. The encapsulated camera is shown in figure 11 without the lens assembly; note the bead of sealant around the CCD.

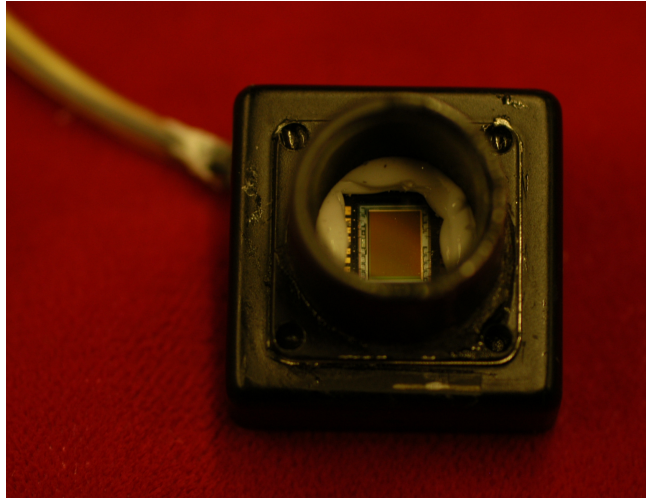

Figure 11. Encapsulated camera showing the RTV sealant around the CCD.

The camera was mounted to the shock table in its shock fixture, shown in figure 12, and shock tested to a peak acceleration of 8085 g's, as measured by an accelerometer mounted to the fixture. The video output of the camera was observed on a black-and-white monitor during the shock event. The camera survived the shock event, as noted by the clear video image on the monitor after the test.



Figure 12. Camera fixture mounted to MTS shock table.

After both the transmitter and camera successfully passed the survivability tests, the components were installed in the imager round and the round was mounted to the shock table, as seen in figure 13. The transmitter signal was received by a GCU which includes a small screen displaying the video signal.

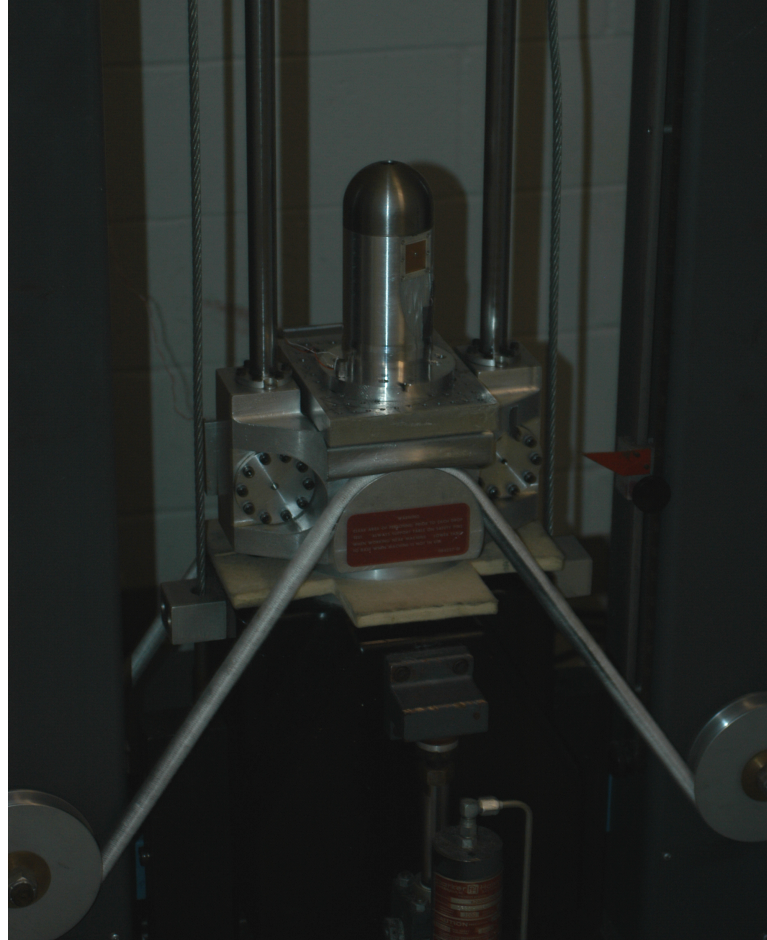

Figure 13. Imager round mounted to shock table.

The imager round was subjected to a shock test in which the peak acceleration was measured at 7532 g's. During the shock event, the video stopped and the video output of the GCU turned black. The GCU controller showed some type of white streaks but no intelligible images. The imager round was disassembled to determine the cause of failure. We removed the camera from the round and tested it by connecting it to a 12-volt power supply and a small black-and-white monitor. Testing of the individual components revealed that the camera was no longer functional and had failed during the shock test. To ensure that the transmitter was not damaged, a new camera was connected to the transmitter and a normal video signal was received by the GCU. To ensure that the camera failure was not an anomaly, another test of the imager at a similar shock level was conducted; the recorded shock is shown in figure 14. This camera was also slightly modified in that the connector for the video and power leads was removed and leads

were soldered directly to the through-holes on the circuit board before encapsulation. Again, the camera failed in exactly the same way; replacement of the camera indicated that the transmitter was undamaged.

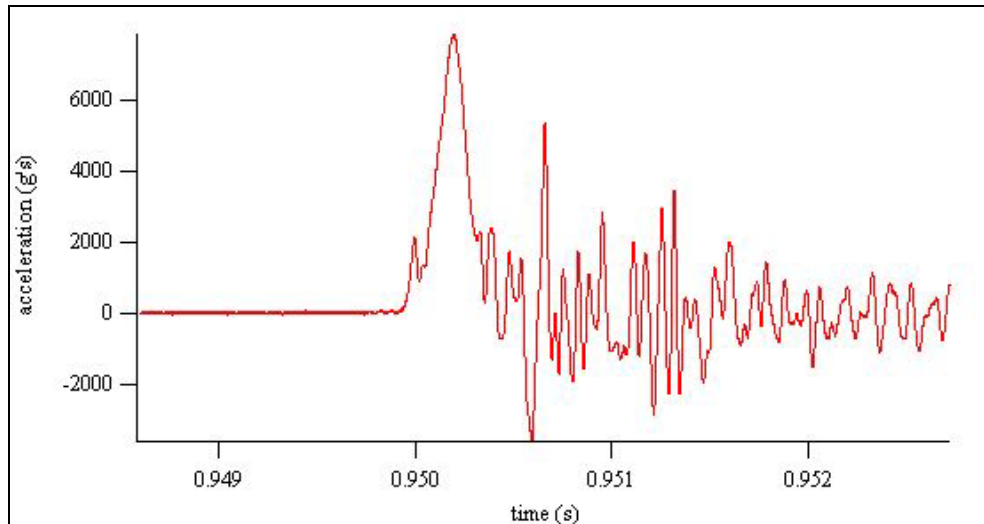

Figure 14. Recorded shock pulse during test of video imager.

To eliminate any possibility that other components contributed to the camera failure, a third shock test was conducted. In this test, the camera was attached to the shock table frame with wire leads running into the video imager round where the power supply and transmitter were connected. The round was shock tested at a maximum shock of approximately 7500 g's. During this test, all the components functioned during shock, which indicated that the camera failure was probably attributable to the physical mounting in the modified round.

In an attempt to determine the cause of failure, FEA was performed on both the camera mounting plate and the camera mounting box with ALGOR¹². A static analysis was conducted on the camera mounting plate. The plate was constrained from movement in the axial direction of the round by the screw holes. A force of 525 newtons was applied to the pocket where the camera sits. The analysis, shown in figure 15, predicts that the maximum deflection of the plate in the axial direction occurs at the center of the pocket and is equal to 1.228×10^{-5} m.

Several different analyses of the mounting box were conducted. To simplify the calculations, a static analysis was used. The force applied to the piece is equal to 1/3 the launch acceleration multiplied by the mass of the camera. This analysis assumes that the force applied to the mounting box will be at a maximum as the round leaves the barrel. This acceleration can be assumed to be approximately an order of magnitude less than the launch acceleration (Barrett, 2004). To ensure that sufficient loading is applied, the set-forward acceleration is assumed to be 1/3 the launch acceleration. The analysis indicates that a deflection of 2.57×10^{-5} m is possible,

¹² ALGOR®, which is not an acronym, is a registered trademark of ALGOR, Inc., 150 Beta Dr., Pittsburgh, PA, 15238-2932.

given the specified acceleration. A graph showing the displacements in the axial direction is presented in figure 16.

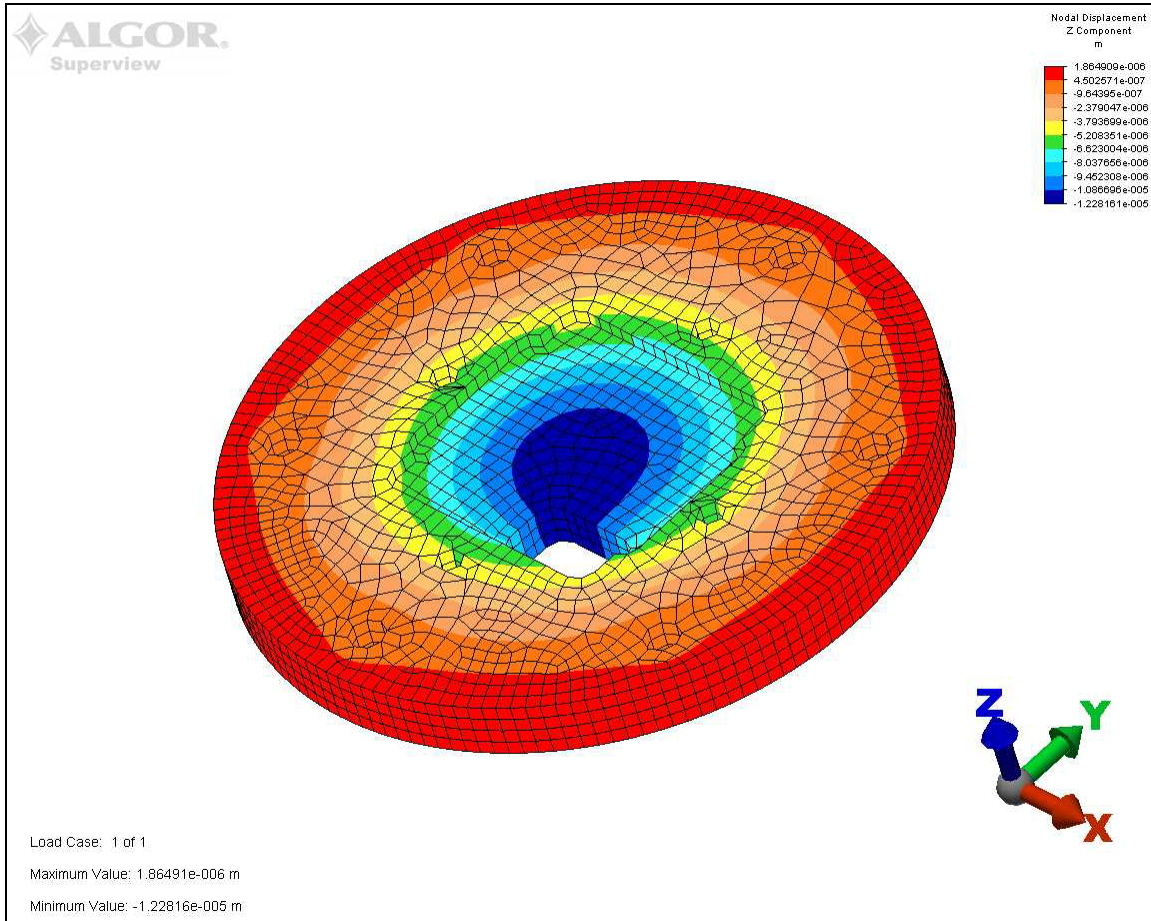

Figure 15. Displacement graph of the camera mounting plate from FEA.

The top piece of the camera shock fixture was analyzed and ALGOR predicted a displacement of 9.9×10^{-7} m. The difference in displacement is apparently the cause for the camera failure. While the deflection of the camera mounting plate and mounting box is small, a component of the acceleration present in these parts, which was not present in the more rigid shock fixture, likely caused a failure of one or more of the camera components.

The author was then referred to an ARL report (Condon et al., 2001), which detailed a similar problem that was encountered during the shock testing of a Polaris Industries camera. To harden the camera for gun launch, the authors replaced a can-type crystal oscillator with a surface mount crystal before encapsulating the camera. This change allowed the camera to survive much higher accelerations than possible with the original component. Originally, the intention was to procure surface mount crystals for the PC182XS camera and try the same approach to harden the cameras. Dove Electronics was contacted about the possibility of acquiring new crystals but the clock frequency of 28.563 Mhz for the camera is a non-standard frequency. In order to acquire crystals

at that frequency, approximately four months would be required for development and testing. To avoid the delay, a faster path was chosen. During further work by one of the authors of ARL-MR-510 (John Condon of ARL), it was discovered that a second camera, the Supercircuits PC72, uses the same clock frequency as the Polaris Industries camera. The PC72 camera is slightly larger than the PC182 but shares a similar form factor. To determine if the PC72 camera would meet the requirements for the concept, several copies of the PC72XS camera were obtained and tested. To harden the camera, the procedure described in ARL-MR-510 was followed. The can-type crystal in the camera was replaced with the Statek¹³ surface mount crystal (part I.D. 4AT-4520-ASXI; description: CX4HGSM1-18.869-MHz crystal oscillator) which was available from parts from work done by John Condon (see figure 17).

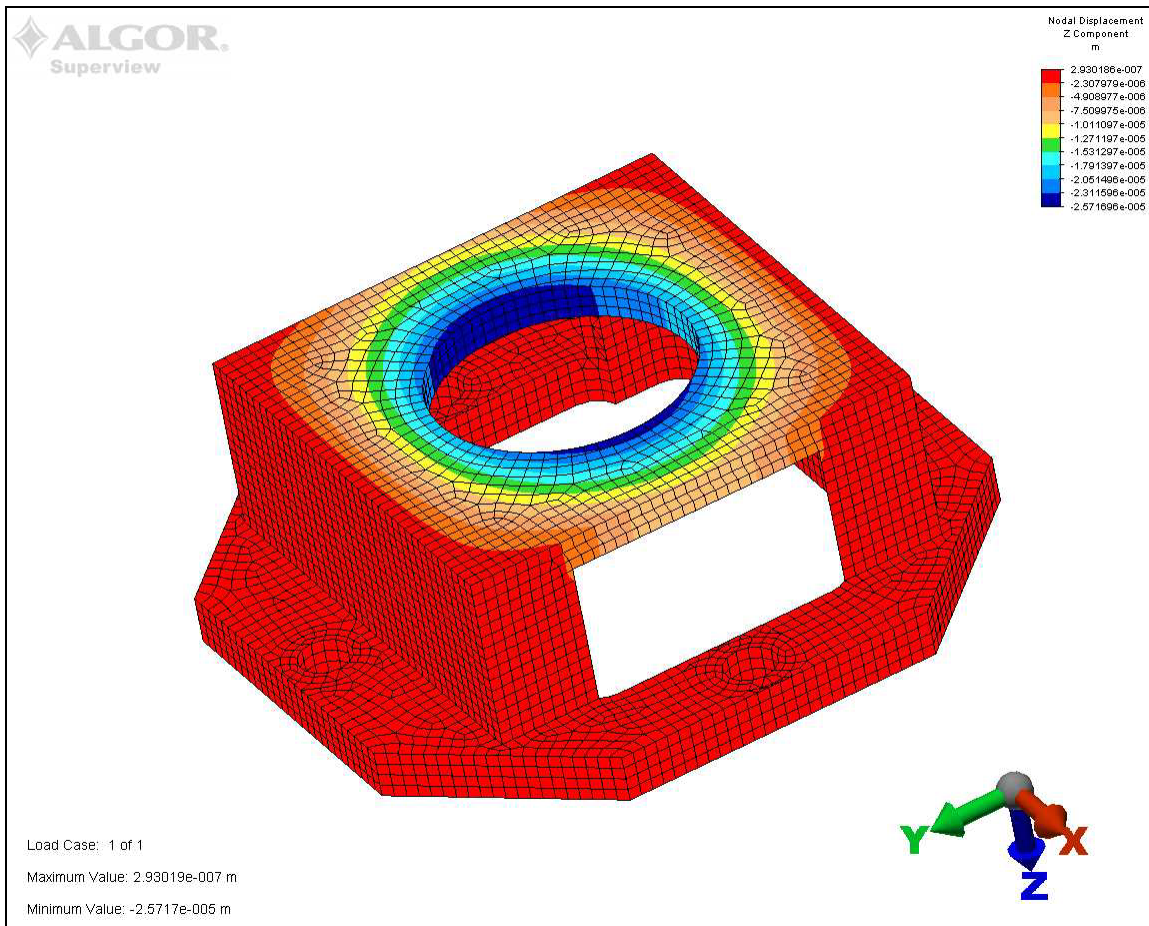

Figure 16. Displacement graph of the mounting box from FEA.

¹³Statek™ is a trademark of Statek Corporation, 512 North Main Street Orange, CA 92868.

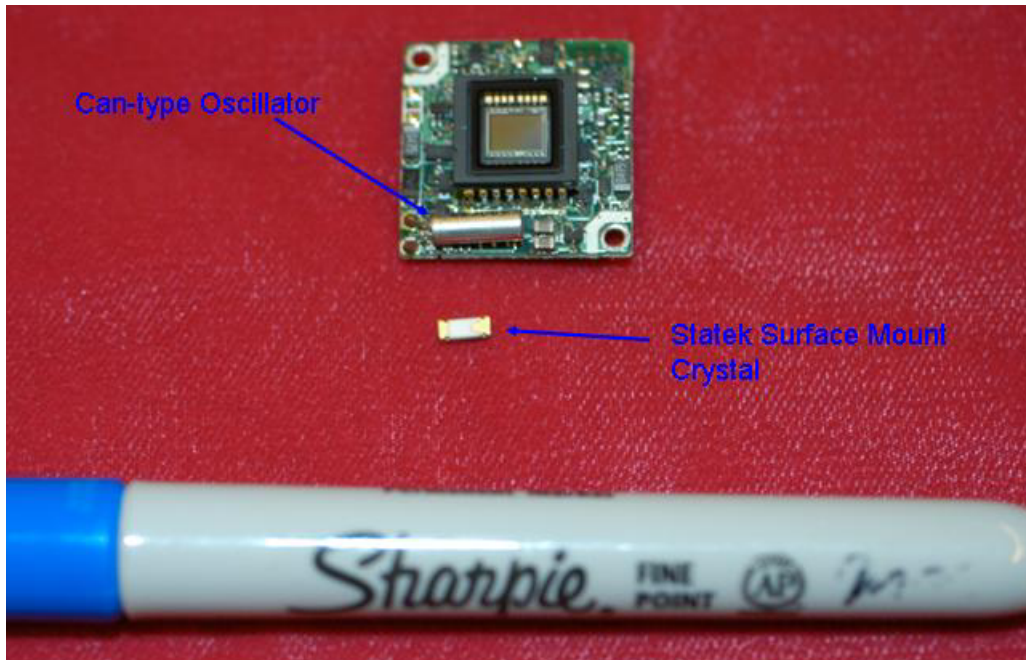

Figure 17. PC72XS camera circuit board with Statek crystal.

As with the previous test, the power and video connector was replaced with wires directly soldered to the circuit board. The CCD was sealed to the lens housing with Dow Corning RTV and the camera was encapsulated with STYCAST 1090SI with an LV23 catalyst. To allow for the installation of the PC72XS camera in the imager round, the camera mounting plate and mounting box designs were modified to fit the new camera (see appendix A). The only change in the camera mounting plate was the shape of the pocket, which was assumed to have a negligible effect on the stress in the plate under load. The mounting box (mounting box rev1) was redesigned to better distribute the clamping force on the camera (see appendix A). Several analyses of the revised mounting box were conducted to ensure that the displacement of the mounting box is smaller than the original version. Figure 18 shows the nodal displacement in the axial direction of the revised mounting box under the same loading conditions in figure 16. The maximum displacement in the axial direction of the revised part is approximately half the displacement of the original.

A second analysis was conducted to simulate the dynamic effects of the actual situation. This analysis was a quarter symmetry model which used a square block to simulate the mass of the camera. The starting position of the mass was 0.004 inch from the mounting box and the mass was driven toward the mounting box with an acceleration equal to that experienced by the BDM at launch. This analysis simulates an acceleration that is significantly more than what should be experienced. The maximum acceleration of the camera toward the mounting box occurs as the round leaves the barrel. Again, the acceleration was assumed to be 1/3 the launch acceleration. Any results from this analysis can be assumed to be significantly higher than that experienced.

The dynamic analysis predicts that the maximum displacement of the mounting box is 2.22×10^{-6} m. Figure 19 shows the graph of the displacement of the mounting box.

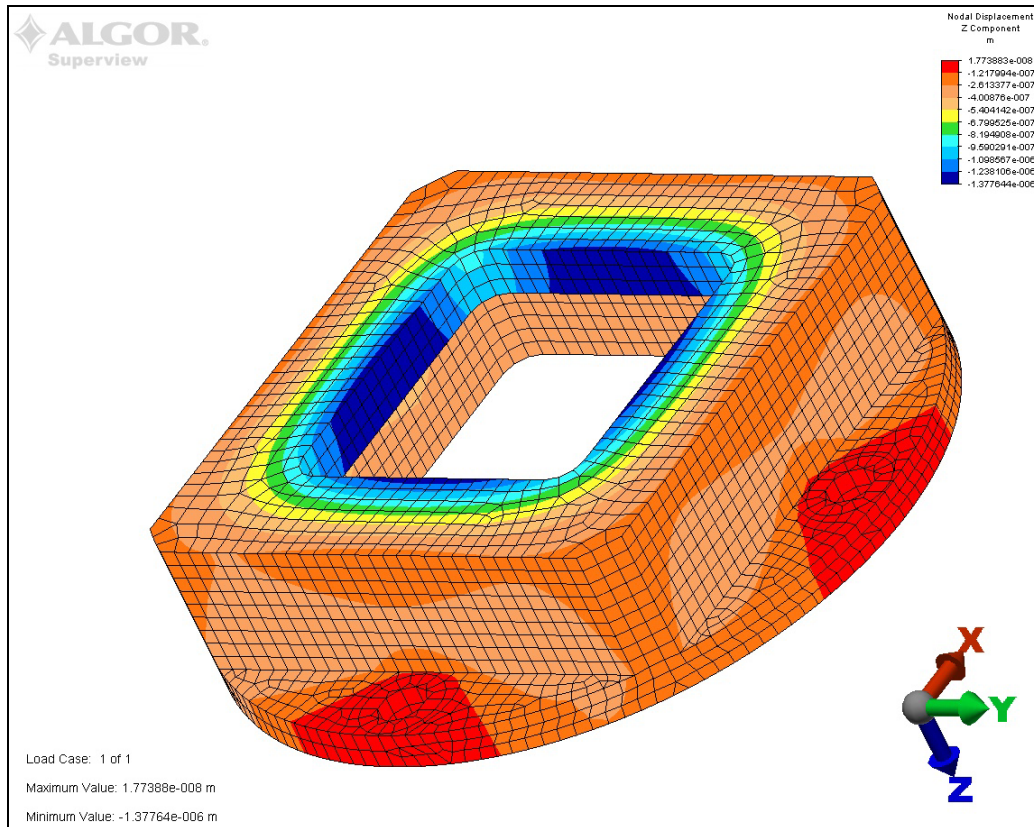

Figure 18. Displacement of revised mounting box.

After manufacture of the revised mounting box and camera mounting plate, the camera was mounted in the round. The camera was supplied with power from a DC power source, and the video leads were connected to an analog-to-digital (A/D) converter and laptop to record the image. The round was shock tested at a maximum acceleration of 8071 g's. The camera functioned successfully through the entire shock event.

The rest of the components including the transmitter were installed in the round and the entire unit was shock tested. The maximum acceleration reached in this test was approximately 8600 g's. The GCU was connected to the A/D converter and the laptop as before. The camera and transmitter both survived the shock event, but two problems were encountered. The camera lens assembly failed in two locations; the outer lens and the lens closest to the CCD both cracked. This was probably because of the unexpectedly high acceleration that was greater than intended. For this reason, no action was taken to solve this problem. The second failure was the transmitter case. The case separated from the base plate and the glass beads fell out. Despite this, the transmitter was fully functional. To solve the two problems, a new lens assembly was mounted in the camera and the transmitter case was soldered together and refilled with glass

beads. After assembly, the transmitter holes and openings were sealed with J-B weld¹⁴ instead of RTV. This was done because previous tests have shown that the RTV can separate from the case and allow small amounts of the glass beads to fall out of the case.

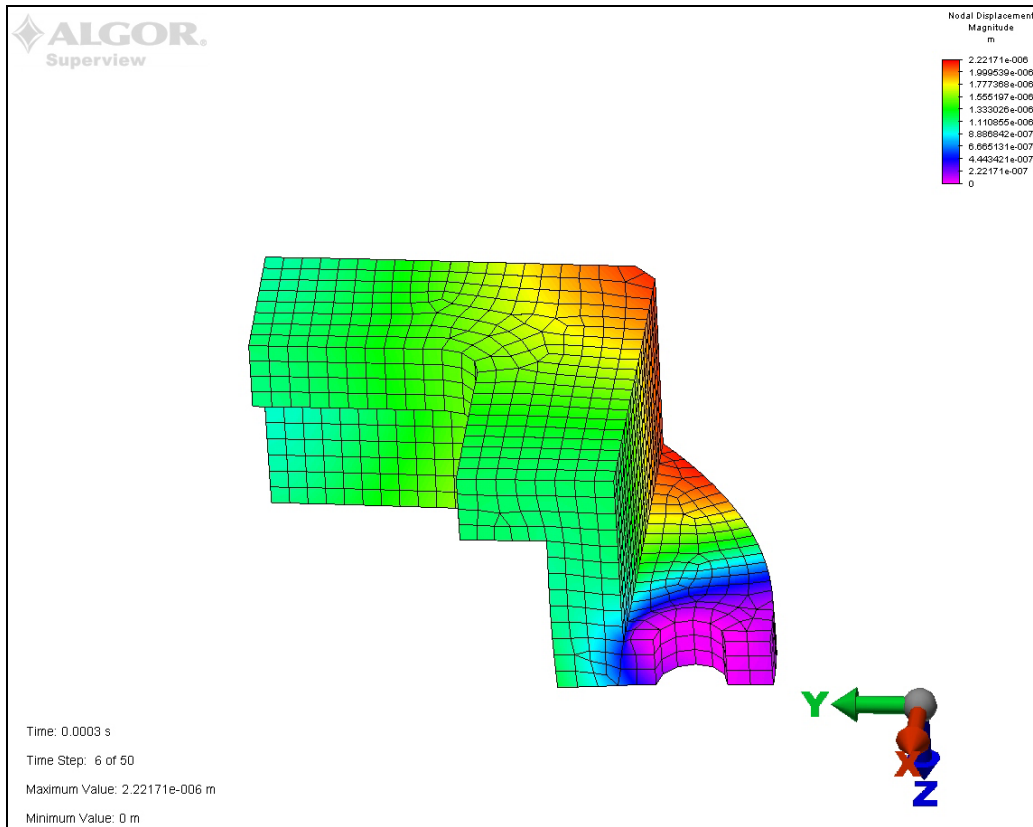

Figure 19. Displacement of the camera mounting box in dynamic analysis.

Another shock test was conducted of the entire unit after assembly. The maximum acceleration of this test was 7347 g's. As before, the video output was recorded and the pre-shock and post-shock images are shown in figures 20 and 21.

These images are seemingly identical, indicating that the camera and transmitters survived shock without failure. The second video imager unit was similarly assembled and tested and the transmitter and camera survived the shock without incident.

¹⁴J-B Weld Company, P.O. Box 483, Sulphur Springs, TX 75483.

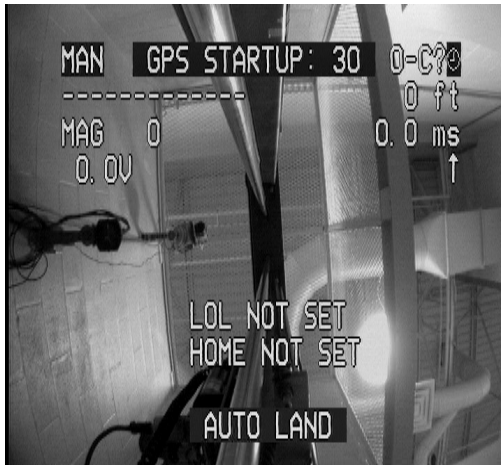

Figure 20. Pre-shock video image.



Figure 21. Post-shock video image.

6. Conclusion

The preparation and testing detailed in this report have allowed for reliable use of the PC72XS camera and VNTX transmitter in gun-launched applications with launch accelerations as great as 7347 g's. With some effort to find a suitable lens able to withstand the acceleration, the camera electronics are able to survive loads at least as great as 8600 g's. The transmitter has demonstrated an ability to withstand accelerations as great as 8600 g's as long as some work is done to ensure that the case is reliably soldered so that it will not separate at shock.

Based on this testing, the two components here are suitably hardened for use in the shoulder-fired video imager project. Further work could be done to test the maximum survivability of these two items if need be. It is also suggested that the same approach to replacing the crystal be attempted with the PC182XS camera to determine its ability to withstand shock since this camera has a unique low light and high resolution capability that may be of use in future projects.

7. References

- Barrett, R. *Design and Testing of Piezoelectric Flight Control Actuators for Hard-Launched Munitions*; Technical University Delft: Netherlands, March 2004.
- Condon, J.A.; McLaughlin, J.T.; Mitchell, C.E. *Shock Hardening and Testing of Munition-Deployed Video Imager Subassembly Components*; ARL-MR-510; U.S. Army Research Laboratory: Aberdeen Proving Ground, MD, 2001.

INTENTIONALLY LEFT BLANK

DESIGNER	DATE	APPROVED

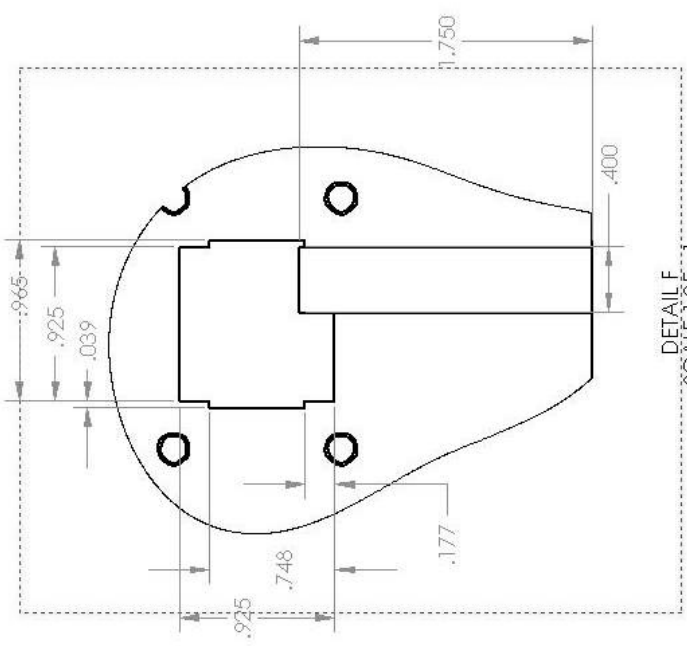
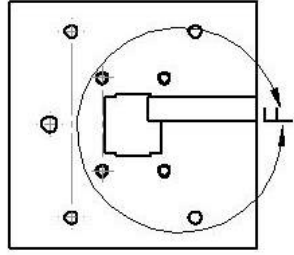

DETAIL F
SCALE 1.35:1

UNLESS OTHERWISE SPECIFIED:		NAME	DATE	ARMY RESEARCH LABORATORY	
DIMENSIONS ARE IN INCHES		MLN	13.11.03	TITLE: CAMERA TEST MOUNT BASE	
TOLERANCES:		DRAWN		SIZE DWG. NO. A REV	
FRACTIONAL: .015		CHECKED		SCALE: 1:2 WEIGHT: SHEET 2 OF 2	
DECIMAL: .001		BYG APPR.			
HOLE POSITION: .005		MFG APPR.			
THREE PLACE DECIMAL: .001		Q.A.			
HOLE LOCATING TOLERANCE REF.		COMMENTS:			
MATERIAL: AL 6061-T6					
FINISH:					
DO NOT SCALE DRAWING					
PROPERTY AND CONFIDENTIALITY INFORMATION CONTAINED HEREIN IS UNCLASSIFIED EXCEPT WHERE SHOWN OTHERWISE. REPRODUCTION IN PART OR AS A WHOLE WITHOUT THE WRITTEN PERMISSION OF THE ARMY RESEARCH LABORATORY IS PROHIBITED.		APPLICATION			
NEEDESTY		BEDON			
5		4		3	
				2	
				1	

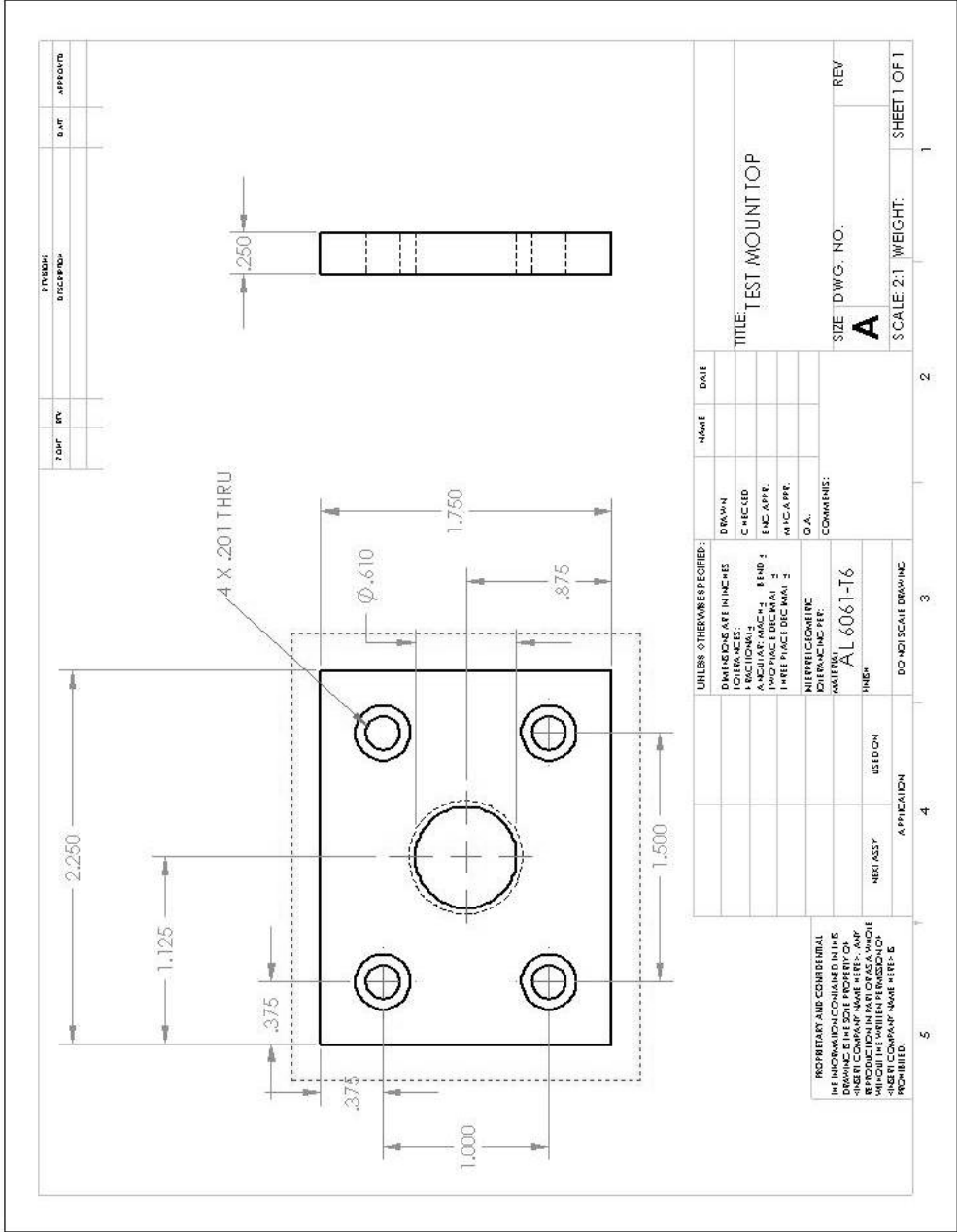

7.DWG	REV	DATE	APPROVED

UNLESS OTHERWISE SPECIFIED:		NAME	DATE
DIMENSIONS ARE IN INCHES	DRAWN		
TOLERANCES:	CHECKED		
ANGULAR	ENG. APP.		
FRACTIONS	DATE		
DECIMALS	SCALE		
THREE PLACE DECIMAL	DATE		
FOUR PLACE DECIMAL	DATE		
FIVE PLACE DECIMAL	DATE		
SIX PLACE DECIMAL	DATE		
SEVEN PLACE DECIMAL	DATE		
EIGHT PLACE DECIMAL	DATE		
NINE PLACE DECIMAL	DATE		
TEN PLACE DECIMAL	DATE		
ELEVEN PLACE DECIMAL	DATE		
TWELVE PLACE DECIMAL	DATE		
THIRTEEN PLACE DECIMAL	DATE		
FOURTEEN PLACE DECIMAL	DATE		
FIFTEEN PLACE DECIMAL	DATE		
SIXTEEN PLACE DECIMAL	DATE		
SEVENTEEN PLACE DECIMAL	DATE		
EIGHTEEN PLACE DECIMAL	DATE		
NINETEEN PLACE DECIMAL	DATE		
TWENTY PLACE DECIMAL	DATE		
PROPRIETARY AND CONFIDENTIAL	DATE		
THE INFORMATION CONTAINED IN THIS	DATE		
DRAWING IS THE SOLE PROPERTY OF	DATE		
AND IS NOT TO BE REPRODUCED OR	DATE		
TRANSMITTED IN ANY FORM OR BY	DATE		
ANY MEANS, ELECTRONIC OR MECHANICAL,	DATE		
INCLUDING PHOTOCOPYING, RECORDING,	DATE		
OR BY ANY INFORMATION STORAGE AND	DATE		
RETRIEVAL SYSTEM, WITHOUT THE WRITTEN PERMISSION	DATE		
OF THE COMPANY NAME HEREIN.	DATE		
PROHIBITED	DATE		

TITLE TEST MOUNT TOP

SIZE DWG. NO. REV

A

SCALE: 2:1 WEIGHT: SHEET 1 OF 1

PROPRIETARY AND CONFIDENTIAL
 THE INFORMATION CONTAINED IN THE
 DRAWING IS THE SOLE PROPERTY OF
 AND IS NOT TO BE REPRODUCED OR
 TRANSMITTED IN ANY FORM OR BY
 ANY MEANS, ELECTRONIC OR MECHANICAL,
 INCLUDING PHOTOCOPYING, RECORDING,
 OR BY ANY INFORMATION STORAGE AND
 RETRIEVAL SYSTEM, WITHOUT THE WRITTEN PERMISSION
 OF THE COMPANY NAME HEREIN.
 PROHIBITED

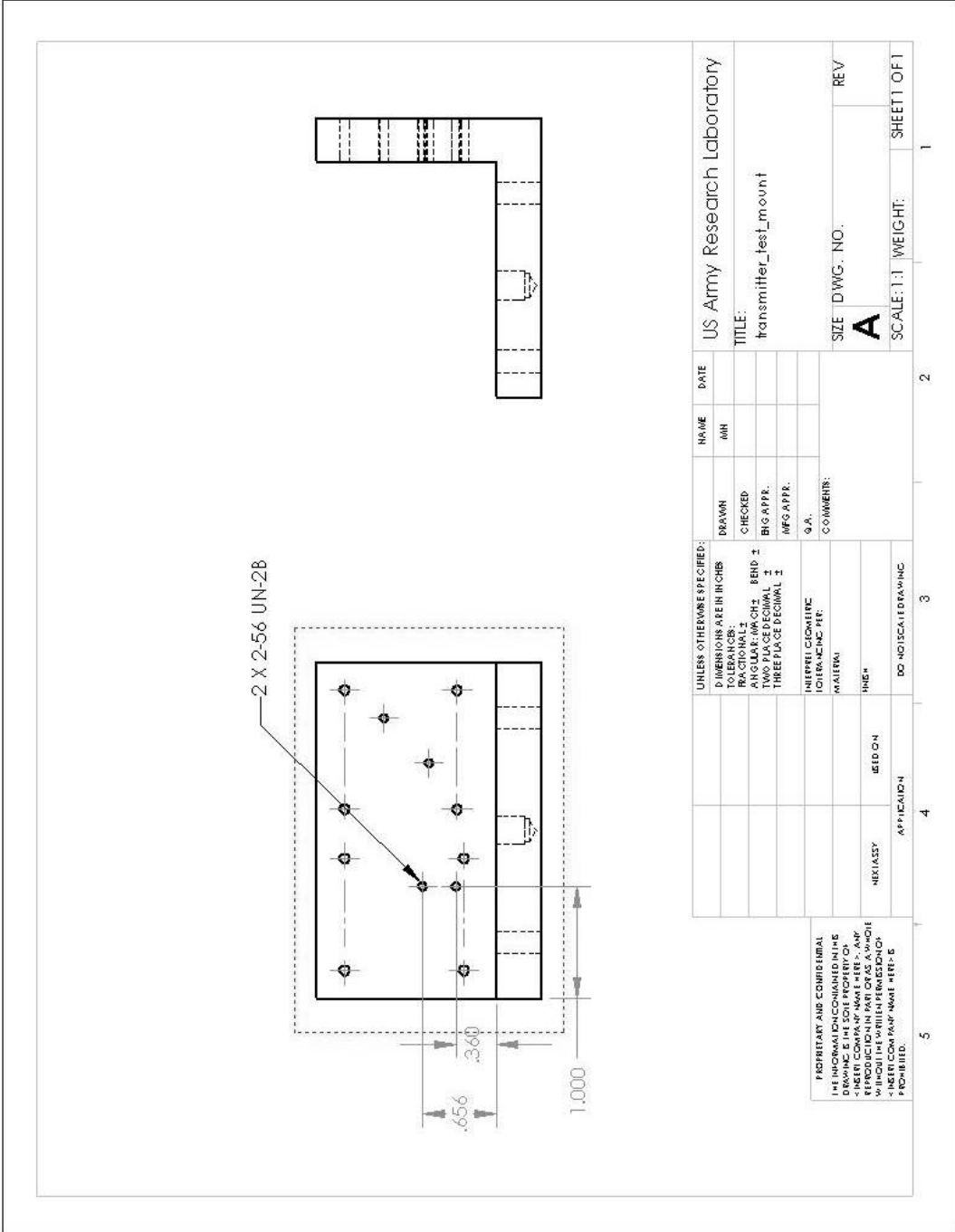

2 X 2-56 UN-2B

1.000
0.656
0.360

UNLESS OTHERWISE SPECIFIED:		NAME	DATE	US Army Research Laboratory	
DIMENSIONS ARE IN INCHES		MR		TITLE:	
TOLERANCES:		DRAWN		transmitter_test_mount	
FRACTIONAL		CHECKED		SIZE DWG: NO.	
DECIMALS		BIG APPR.		A	
THREE PLACE DECIMALS		MFG APPR.		SCALE: 1:1 WEIGHT:	
		Q.A.		SHEET 1 OF 1	
		COMMENTS:			
INTERPRETATION:					
MATERIAL:					
FINISH:					
APPLICATION					
NEXT ASSY					
BED ON					
DO NOT SCALE DRAWING					

PROPRIETARY AND CONFIDENTIAL
 THE INFORMATION CONTAINED IN THIS
 DRAWING IS THE SOLE PROPERTY OF
 AMERICAN COMPAQ COMPUTER COMPANY
 AND IS TO BE USED ONLY FOR THE
 PROJECT AND FOR WHICH IT WAS
 WITHOUT THE WRITTEN PERMISSION
 PROHIBITED.

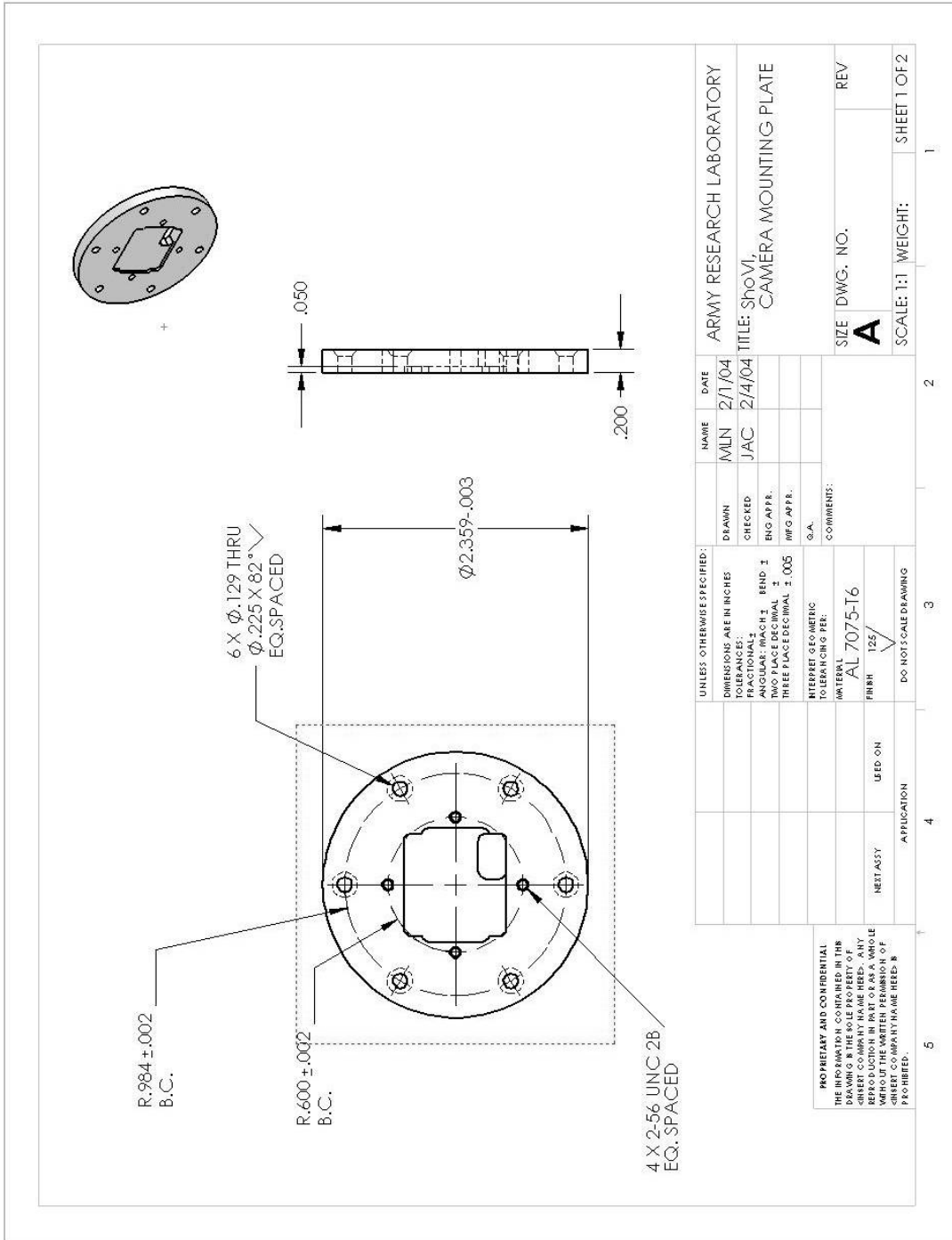

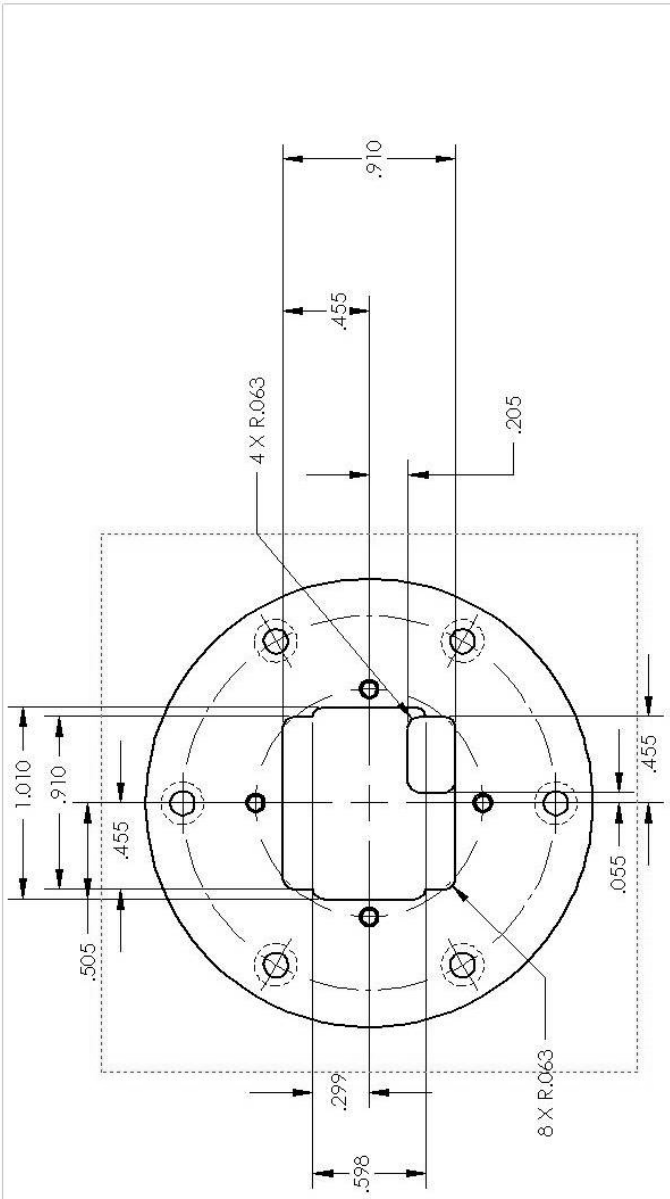

UNLESS OTHERWISE SPECIFIED:		NAME	DATE	ARMY RESEARCH LABORATORY
DIMENSIONS ARE IN INCHES		MLN	2/1/04	
TOLERANCES:		JAC	2/4/04	TITLE: SHOVI
FRACTIONS: THRU 1/16				CAMERA MOUNTING PLATE
ANGULAR: MACH 1 FEND 1				
TWO PLACE DECIMAL 3				
THREE PLACE DECIMAL 1.003				
INTERNET GEOMETRIC TOLERANCING PER:				
MATERIAL: AL 7075-T6				SIZE DWG. NO. REV
FINISH: 125				A
NET/ASSY	USED ON			SCALE: 1:1 WEIGHT: SHEET 2 OF 2
APPLICATION	DO NOT SCALE DRAWING			
5	4	3	2	1

PROPRIETARY AND CONFIDENTIAL
 THIS DRAWING IS THE PROPERTY OF THE ARMY RESEARCH LABORATORY. ANY REPRODUCTION IN PART OR AS A WHOLE WITHOUT THE WRITTEN PERMISSION OF THE ARMY RESEARCH LABORATORY IS PROHIBITED.

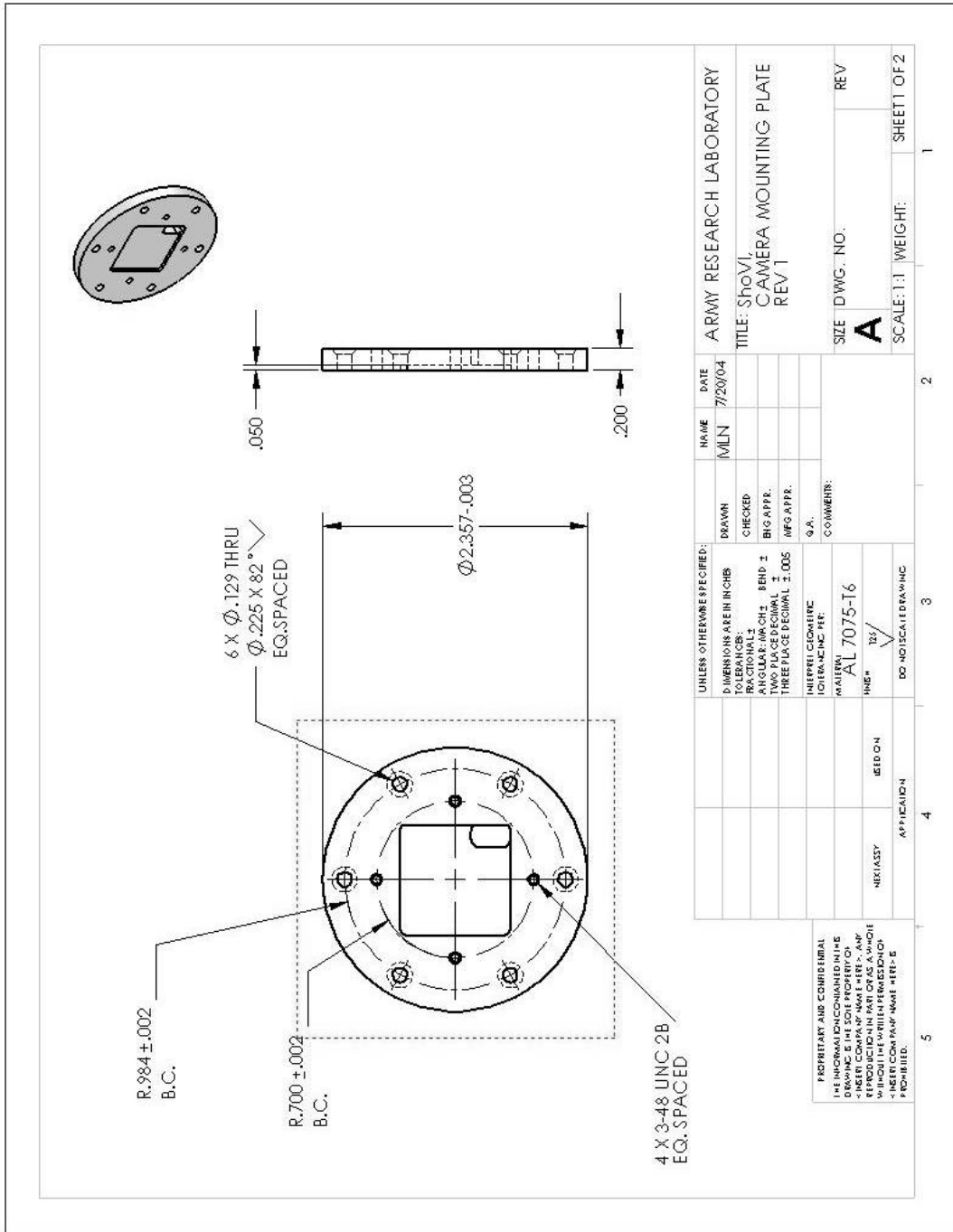

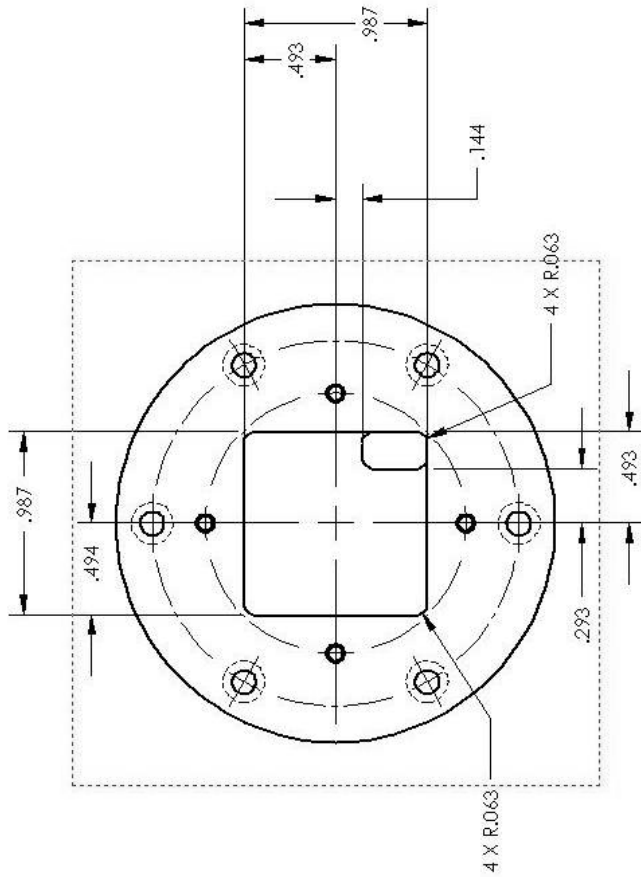

UNLESS OTHERWISE SPECIFIED:		NAME	DATE	ARMY RESEARCH LABORATORY
DIMENSIONS ARE IN INCHES	DRAWN	MLN	2/1/04	TITLE: SpOVI,
FRACTIONAL	CHECKED	JAC	2/4/04	CAMERA MOUNTING PLATE
ANGULAR: MAX CHG - BEND ±	BIG APPR.			
TWO PLACE DECIMAL ±	MFG APPR.			
THREE PLACE DECIMAL ± .003	O.A.			
INTERPREL COUNTRY:	COMMENTS:			SIZE DWG. NO. REV
INTER-ACNC REF.	AL 7075-16			A
MATERIAL:	INCH			SCALE: 1:1 WEIGHT: SHEET 2 OF 2
NEXT ASSY	BEZEL ON			
APPLICATION	DO NOT SCALE DRAWING			

PROPRIETARY AND CONFIDENTIAL
 THE INFORMATION CONTAINED IN THIS
 DRAWING IS THE SOLE PROPERTY OF
 AMERICAN COMPOSITE MATERIALS, AND
 IS NOT TO BE REPRODUCED, COPIED,
 OR TRANSMITTED IN ANY FORM OR BY
 ANY MEANS, WITHOUT THE WRITTEN PERMISSION
 OF AMERICAN COMPOSITE MATERIALS, INC.
 PROHIBITED.

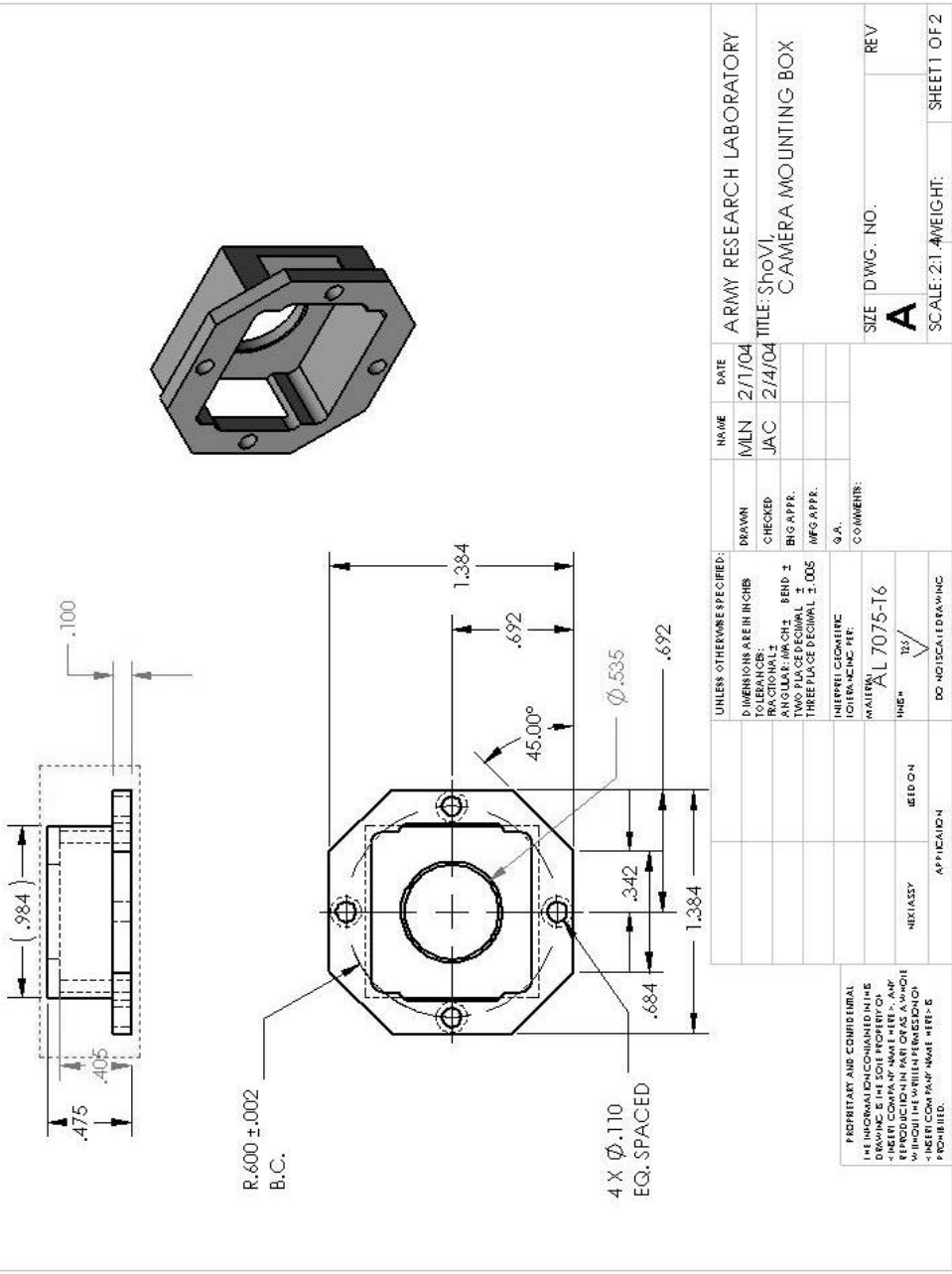

UNLESS OTHERWISE SPECIFIED:		NAME	DATE	ARMY RESEARCH LABORATORY
DIMENSIONS ARE IN INCHES	DRAWN	MLN	2/1/04	TITLE: ShoVI,
FRACTIONAL	CHECKED	JAC	2/4/04	CAMERA MOUNTING BOX
ANGULAR: IN/CH	BIG APPR.			
TWO PLACE DECIMAL	MFG APPR.			
THREE PLACE DECIMAL	O.A.			
INTERPRELICATION:	COMMENTS:			SIZE DWG. NO. REV
INTER-NC NC				A
MATERIAL	AL 7075-T6			SCALE: 2:1
FINISH	TS/			WEIGHT:
DO NOT SCALE DRAWING				SHEET 1 OF 2

PROPRIETARY AND CONFIDENTIAL
 THE INFORMATION CONTAINED IN THIS
 DRAWING IS THE SOLE PROPERTY OF
 AMERI COMPA NY NAME HEREIN, AND
 IS NOT TO BE REPRODUCED, COPIED,
 OR TRANSMITTED IN ANY FORM OR BY
 ANY MEANS, WITHOUT THE WRITTEN PERMISSION
 OF AMERI COM PA NY NAME HEREIN. THIS
 PROHIBITION IS NOT TO BE INTERPRETED AS
 PROHIBITING THE REPRODUCTION OF
 INFORMATION CONTAINED HEREIN THAT IS
 NECESSARY TO THE PRODUCTION OF
 EQUIPMENT IDENTICAL TO THAT
 IDENTIFIED IN THIS DRAWING.

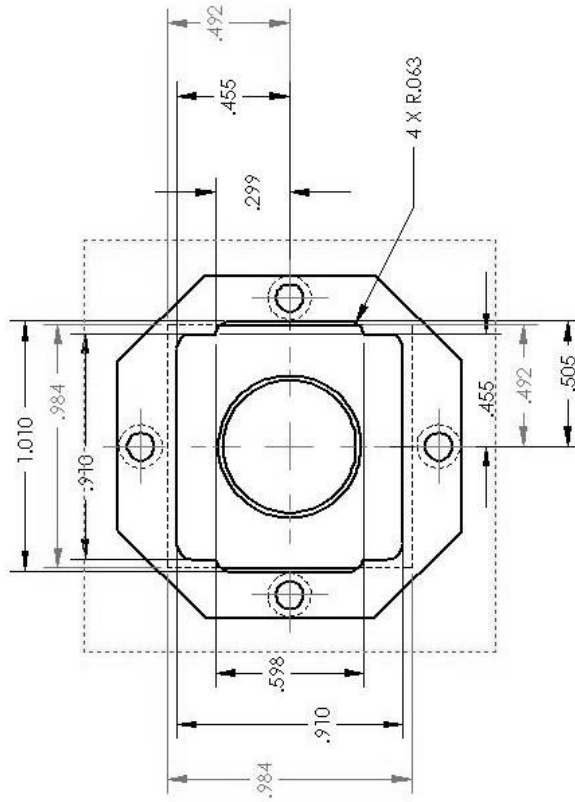

UNLESS OTHERWISE SPECIFIED:		NAME	DATE	ARMY RESEARCH LABORATORY	
DIMENSIONS ARE IN INCHES	DRAWN	MLN	2/1/04	TITLE: SHOVI CAMERA MOUNTING BOX	
FRACTIONAL	CHECKED	JAC	2/4/04	SIZE DWG. NO. REV	
ANGULAR: MM CH1 BEND 1	BIG APPR.			A	
TWO PLACE DECIMAL 1	MFG APPR.			SCALE: 2:1 WEIGHT: SHEET 2 OF 2	
THREE PLACE DECIMAL 1.000	Q.A.				
INTERPREL COUNTRY	COMMENTS:				
INTER-NC NC					
MATERIAL	AL 7075-T6				
FINISH	TY				
NECESSARY	BEZEL ON				
APPLICATION					

PROPRIETARY AND CONFIDENTIAL
 THE INFORMATION CONTAINED IN THIS
 DRAWING IS THE SOLE PROPERTY OF
 AMERI COMPANY NAME HERE, AND
 IS NOT TO BE REPRODUCED, COPIED,
 OR TRANSMITTED IN ANY FORM OR BY
 ANY MEANS, WITHOUT THE WRITTEN PERMISSION
 OF AMERI COMPANY NAME HERE, IS
 PROHIBITED.

NO. OF
COPIES ORGANIZATION

* ADMINISTRATOR
DEFENSE TECHNICAL INFO CTR
ATTN DTIC OCA
8725 JOHN J KINGMAN RD STE 0944
FT BELVOIR VA 22060-6218
*pdf file only

1 DIRECTOR
US ARMY RSCH LABORATORY
ATTN IMNE AD IM DR MAIL & REC MGMT
2800 POWDER MILL RD
ADELPHI MD 20783-1197

1 DIRECTOR
US ARMY RSCH LABORATORY
ATTN AMSRD ARL CI OK TECH LIB
2800 POWDER MILL RD
ADELPHI MD 20783-1197

2 DIRECTOR
US ARMY RSCH LABORATORY
ATTN AMSRD ARL SE RL M DUBEY
B PIEKARSKI
2800 POWDER MILL RD
ADELPHI MD 20783-1197

2 DIRECTOR
US ARMY RSCH LABORATORY
ATTN AMSRD ARL SE RM
AMSRD ARL SE SS LADAS
2800 POWDER MILL RD
ADELPHI MD 20783-1197

1 PROGRAM MGR ITTS
STRICOM
ATTN AMFTI EL D SCHNEIDER
12350 RESEARCH PKWY
ORLANDO FL 32826-3276

1 US ARMY CECOM RDEC
ATTN AMSEL RD NV AS UEA
G KLAUBER
10221 BURBECK ROAD
FORT BELVOIR VA 22060-5806

2 AEROVIRONMENT INC
ATTN C MIRALLES
4685 3H INDUSTRIAL ST
SIMI VALLEY CA 93063

1 CDR USARDECOM ARDEC
ATTN AMSRD AAR AEM L M FRANZ
BLDG 65S
PICATINNY ARSENAL NJ 07806-5000

NO. OF
COPIES ORGANIZATION

ABERDEEN PROVING GROUND

1 DIRECTOR
US ARMY RSCH LABORATORY
ATTN AMSRD ARL CI OK (TECH LIB)
BLDG 4600

2 CDR USA AMSAA
ATTN AMXSY EF
AMXSY EV
BLDG 392

1 US ARMY EVALUATION CMD
ATTN USA CSTE EAC AZ R MIRABELLE
BLDG 4120

2 CDR US ARMAMENT RD&E CTR
ATTN AMSTA AR FST T J MATTS
J WHITESIDE
BLDG 120

1 CDR USA DTC
ATTN CSTE DTC TTM J SCHNELL
RYAN BLDG

3 DIR USARL
ATTN AMSRD ARL WM J SMITH
AMSRD ARL WM SG T ROSENBERGER
H WALLACE
BLDG 4600

2 DIR USARL
ATTN AMSRD ARL WM B D LYON
W CIEPIELLA
BLDG 4600

10 DIR USARL
ATTN AMSRD ARL WM BA T BROWN
F BRANDON J CONDON
M CHILDERS R MCGEE
M NAIR (5 CYS)
BLDG 4600

1 DIR USARL
ATTN AMSRD ARL WM BC P PLOSTINS
BLDG 390

2 DIR USARL
ATTN AMSRD ARL WM BF H EDGE T HAUG
BLDG 390

2 DIR USARL
ATTN AMSRD ARL WM RP J BORNSTEIN
C SHOEMAKER
BLDG 1121