

# Using Visualization to Address Human Capacity Limitations

## Syndicate 3

**Justin G. Hollands**

**Reinert Korsnes**

**James Llinas**

**Geir Ovsttun**

**Thomas Porathe**

**Joanne Treurniet**

### **ABSTRACT**

*An intriguing aspect of visualization as a technology is that it offers the potential to improve the functional capacity of the human operator. In this report, we discuss how this can be done in a variety of ways: by recoding information, by using multimodal displays, by training, or by using intelligent interfaces, agents, and ontologies. In doing so, we argue that the capacity of the human-machine system should be defined as **distributed working memory** – at information shared between the human and machine when performing a dynamic task. We also discuss how the system design process can be structured to incorporate human capacity.*

### **INTRODUCTION**

We have known for a long time that the main bottleneck in human information processing is not how much of the environment we can perceive using our various sensory systems, nor in how much knowledge we can accumulate. Rather, the tightest constraint lies in how much information we can process simultaneously. This constraint has two key sources: an attentional bottleneck (e.g., Pashler, 1998), and as a constraint in working memory (Baddeley, 1995) or limited mental resources (e.g., Wickens, 1984). In this paper, we attempt to define capacity by briefly reviewing the literature on attention, limitations on our information processing, chunking, working memory, multiple resource theory, and long-term working memory. In so doing, we examine the effects of combining modalities (vision, audition, haptics, kinesthetics). Then we consider technology as a method for increasing capacity, both in terms of improved interface design and by using intelligent systems. We present a model of task demands on working memory, leading to a model of *distributed working memory*. Finally we discuss how the system design process can be structured to incorporate human capacity.

### **Attentional Constraints**

The notion of attention as a spotlight is a useful metaphor. It highlights some of problems we have with attention; sometimes the spotlight is in the wrong place (problem of selective attention), sometimes the spotlight is set too broadly so that irrelevant information intrudes (problem of focused attention); and sometimes it is difficult to broaden the spotlight sufficiently to process all task-relevant information (problem of divided attention) (Wickens & Hollands, 2000). Because it seems most relevant to the process of visualization, we consider here the situation where a task cannot be performed without particular task-relevant information being displayed to the operator. In this context, there appear to be two fundamental problems related to capacity and visual attention. The first is that attention needs to be allocated to task-relevant source or sources. If this fails, and no task relevant information is identified, the operator will fail. To the extent that the operator can identify task-relevant information in the scene, performance will improve. If spatial attention is allocated to inappropriate data sources (the problem of selective attention)

*Paper presented at the RTO IST Workshop on "Massive Military Data Fusion and Visualisation: Users Talk with Developers", held in Halden, Norway, 10-13 September 2002, and published in RTO-MP-105.*

# Report Documentation Page

*Form Approved  
OMB No. 0704-0188*

Public reporting burden for the collection of information is estimated to average 1 hour per response, including the time for reviewing instructions, searching existing data sources, gathering and maintaining the data needed, and completing and reviewing the collection of information. Send comments regarding this burden estimate or any other aspect of this collection of information, including suggestions for reducing this burden, to Washington Headquarters Services, Directorate for Information Operations and Reports, 1215 Jefferson Davis Highway, Suite 1204, Arlington VA 22202-4302. Respondents should be aware that notwithstanding any other provision of law, no person shall be subject to a penalty for failing to comply with a collection of information if it does not display a currently valid OMB control number.

1. REPORT DATE <b>00 APR 2004</b>	2. REPORT TYPE <b>N/A</b>	3. DATES COVERED <b>-</b>	
4. TITLE AND SUBTITLE <b>Using Visualization to Address Human Capacity Limitations Syndicate 3</b>		5a. CONTRACT NUMBER	
		5b. GRANT NUMBER	
		5c. PROGRAM ELEMENT NUMBER	
6. AUTHOR(S)		5d. PROJECT NUMBER	
		5e. TASK NUMBER	
		5f. WORK UNIT NUMBER	
7. PERFORMING ORGANIZATION NAME(S) AND ADDRESS(ES) <b>Halden Norway</b>		8. PERFORMING ORGANIZATION REPORT NUMBER	
9. SPONSORING/MONITORING AGENCY NAME(S) AND ADDRESS(ES)		10. SPONSOR/MONITOR'S ACRONYM(S)	
		11. SPONSOR/MONITOR'S REPORT NUMBER(S)	
12. DISTRIBUTION/AVAILABILITY STATEMENT <b>Approved for public release, distribution unlimited</b>			
13. SUPPLEMENTARY NOTES <b>See also ADM001665, RTO-MP-105 Massive Military Data Fusion and Visualization: Users Talk with Developers., The original document contains color images.</b>			
14. ABSTRACT			
15. SUBJECT TERMS			
16. SECURITY CLASSIFICATION OF:			17. LIMITATION OF ABSTRACT
a. REPORT <b>unclassified</b>	b. ABSTRACT <b>unclassified</b>	c. THIS PAGE <b>unclassified</b>	<b>UU</b>
			18. NUMBER OF PAGES <b>19</b>
			19a. NAME OF RESPONSIBLE PERSON

performance will degrade. This may happen because irrelevant data are highly salient, for example. In some cases, the operator may be able to perform the task even if not all task relevant information is identified (by deduction from obtained information, for example). However it will serve to increase the amount of processing that working memory must do later. If attention is guided using specific display techniques (e.g., Muller & Rabbitt, 1989), then detection of task-relevant information may be aided. Even the best sensor data, data fusion algorithms, and display technology will not aid the operator if the data being collected, fused, and displayed is not relevant to the operator's task. Visualization software is most effective when it presents task-relevant information.

If other data are also portrayed with task-relevant information, the operator should still be able to perform the task. However, this leads to the second problem for capacity and visual attention. If there are too many data sources, performance tends to degrade given attentional limitations. The operator must filter the irrelevant data from the relevant data (producing the problem of focused attention described above), or may find it too difficult to broaden the attentional spotlight sufficiently to attend to all task-relevant information sources (producing the problem of divided attention). What is necessary is to detect task-relevant information in the environment and dynamically allocate attention to those sources. The less irrelevant data there are, the better the operator's performance. Visualization software will be maximally effective when it presents task-relevant information only.

Sometimes however, we are not aware of the location of the task-relevant information and need to search for it. In *visual search* (where an observer searches for a particular target symbol among a set of distractor symbols) there is evidence that some targets can be found very quickly with no penalty for an increase in the number of distractors (efficient search, or *pop out*) (Wolfe, 1997). For example, it is easy to find the sole red symbol in a field of blue symbols. In contrast, visual search for other symbols is less efficient, with search time increasing with the number of distractors (e.g., finding an O in a set of Qs). Careful formatting and well-designed symbology can lead to more efficient search on maps and tactical displays. Some information can be processed with little attentional demand, whereas efficient search reflects a preattentive capacity – bypassing the attentional bottleneck altogether (Treisman & Gelade, 1980). In contrast, controlled search taps attentional resources for the duration of the search. Thus, efficient search has the potential to increase our attentional capacity in terms of bandwidth – reducing the time to find what we seek.

In summary, effective visualization is better realized when task relevant information is presented without extraneous data, or when the task-relevant information is made more salient. If search is necessary, it is better to make the target of that search preattentive, by using unique stimulus levels or dimensions.

### Some Constraints on our Ability to Process Information

In his classic paper, Miller (1956) summarized the large literature on absolute judgment by showing how our capacity to classify alternatives was relatively constant regardless of stimulus type (shapes, sizes, tastes, odors, etc). The magical number was approximately 7 alternatives ( $7 \pm 2$ ). In the absolute judgment task, an observer is presented with a set of stimuli and asked to classify them by name or number. As the number of alternatives in the set is increased, so does the information that a human observer can transmit, but errors start to occur between 2 and 3 bits (4 or 8 stimulus alternatives), with an asymptote of 2.6 bits (7 alternatives).

Later work combining multiple dimensions (e.g., Egeth & Pachella, 1969) showed that this capacity could be increased by having people classify alternatives varying on multiple stimulus dimensions (e.g., length, width, and color). With this technique, capacity can be increased: for example observers can transmit 5.8 bits (or approximately 100 positions) for the spatial position of a dot in a square (two dimensions of length and width). As the number of dimensions is increased beyond two, the amount of information transmitted asymptotes at about 6.8 bits.

The nature of the different dimensions being combined is also important for capacity. Work on multiple resource theory showed that it is possible to perform multiple tasks simultaneously (good *time-sharing*) if they drew upon different resource pools (Wickens & Hollands, 2000). We can divide attention between eye and ear better than between two auditory or visual channels, for example. We can also perform simultaneously a verbal task and a spatial task better than two verbal tasks or two spatial tasks.

In related work, Baddeley (1986, 1995) proposed that *working memory* (WM) can be subdivided into a number of component systems (*articulatory loop* for verbal/phonological processing; *visuospatial sketchpad* for visuospatial processing, and a *central executive* component). There is also evidence for an additional kinaesthetic component used for maintaining information about body position (Woodin & Heil, 1996). Evidence in support of this separation of WM activity is provided by experiments where participants perform multiple tasks simultaneously. As with the multiple resource experiments, interference is observed when two tasks draw on the same component system, but not when the tasks draw on different systems. In summary, results from multiple resource and WM research indicate that capacity can potentially be increased beyond the 6.8 bits limit if we take advantage of different sensory modalities, or different types of processing codes.

Limits on WM capacity are also affected by stress. In particular, although moderate arousal levels can be beneficial to performance, high stress reduces working memory capacity and tends to produce attentional narrowing or cognitive tunnelling (Wickens & Hollands, 2000). The user tends to focus on specific characteristics of the situation and has difficulty switching the focus of attention (*perseveration*). If irrelevant data are presented in a salient manner, this can heighten to focused attention problem for the operator. Increase in stress levels has been shown to interfere with situation awareness, also (Orasanu, 1997). It appears especially important, therefore, to find display techniques that present all task-relevant information to reduce the need for computation, and present task-relevant information to the exclusion of irrelevant data (to reduce the need for attentional filtering).

It is evident that the background or expertise of the user influences processing capacity. For example, it is well known that when a procedure becomes well learned it becomes *automatized*; that is, it requires fewer processing resources, thereby making it easier to perform that task with another task. Thus, expertise in a task domain offers a method for improving performance by reducing WM demands. A second advantage of expertise is that the contents of WM change. Consider, for example, the chess master who can memorize the position of chess pieces after brief presentation (Chase & Simon, 1973). Experts can group or *chunk* relevant information together based on meaning (e.g., chess pieces into chess positions), allowing the operator to maintain much more information in WM (Miller, 1956). Thus, WM capacity is better indexed by chunks than bits. This offers an alternative solution to increasing WM capacity. Indeed, these two processes work together so that using WM contents to access long-term memory may become automatized with sufficient practice or training, offering a *long-term working memory* (LTWM) with immense capacity (Ericsson & Kintsch, 1995). We speculate that since Generation Y are pre-trained on many basic computer interface techniques the current generation of soldiers can take advantage of a wider variety of innovative interfaces to accomplish a task. If a particular response device (e.g., joystick) is highly automatized for a member of Generation Y, its use will not tap WM resources and will not preclude good performance on concurrent tasks.

### FACTORS AFFECTING WORKING MEMORY LOAD

We argue that a variety of factors can serve to reduce demand on working memory resources. These are illustrated in Figure 1, which plots working memory load as a function of a variety of capacity-enhancing strategies. Each vector represents a particular strategy, which we outline below. Because effective visualization designs would probably employ the various strategies in combination, we represent the effect of the strategies on two tasks, A and B, using a hyperplane surface. The effect of each strategy is to

## Using Visualization to Address Human Capacity Limitations

decrease working memory load, although different strategies may have differential effects for particular tasks. The figure depicts Task A as generally requiring greater working memory resources than Task B, although the use of capacity-enhancing strategies could allow WM load for Tasks A and B to be equal.

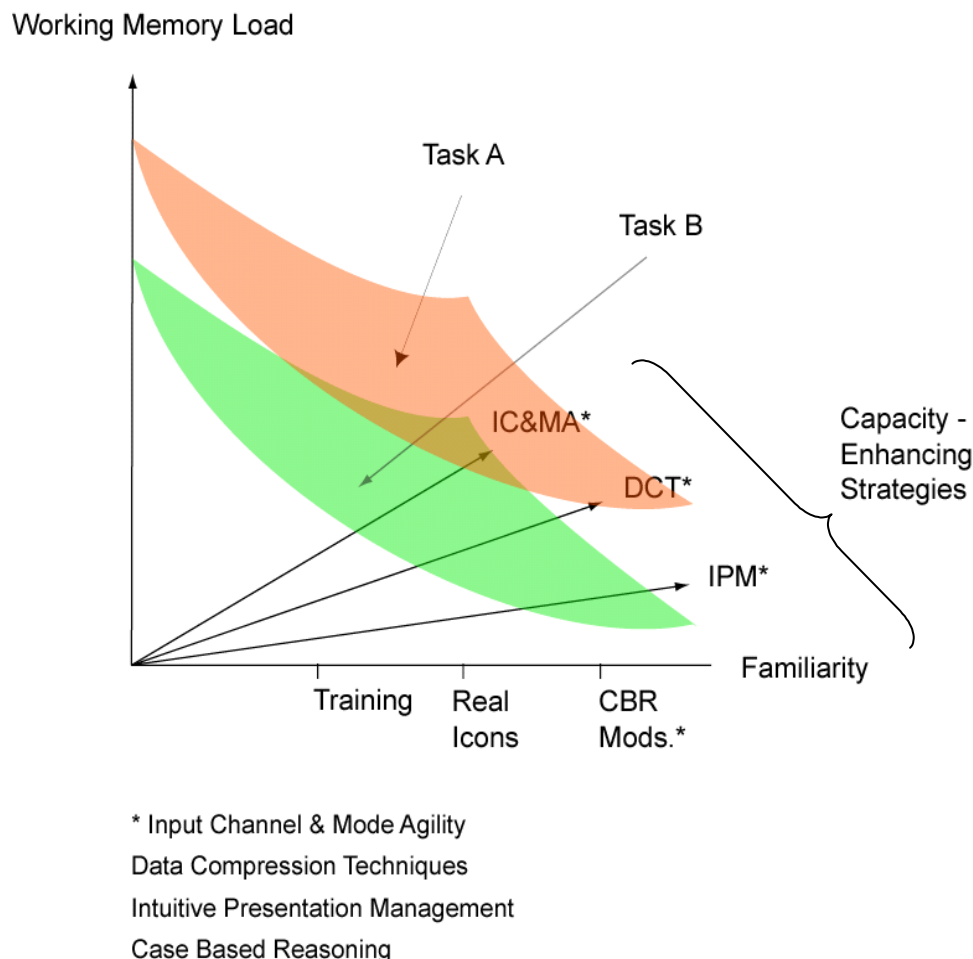

**Figure 1: Working Memory Load as a Function of Several Capacity Enhancing Strategies.**

*Familiarity and case-based reasoning.* As discussed earlier, working-memory load is influenced by familiarity. Familiarity on a task has three key benefits: automaticity, chunking, and automatized long-term memory access (LTWM). Automaticity is typically produced from repetitive experience (training) in the work environment, which can be tremendously useful for repetitive tasks but is also highly specific to particular situations (Schneider & Shiffrin, 1977). The use of LTWM allows for *recognition-primed decision-making*, which asserts that decision options are quickly selected on the basis of familiarity; that is, similarity of the current situation (that portrayed on the display) to previously experienced situations (Klein, 1989). The model in Figure 1 was also influenced by Commanders' (Cols Johansen and Alward, 2002 this workshop) remarks regarding the need for familiarity in all display aspects for efficiency and stress reduction. In the figure, we use the term *case-based reasoning* to indicate more directly the change in the nature of mental processing that occurs with expertise. We view this as a greater change along the familiarity magnitude because it is more flexible and of broader utility.

By finding familiar metaphors in visualization, decision making or problem solving can be reduced to "an already encountered problem", and thus dealt with in a known way. A simple example would be to depict abstract non-spatial data using a familiar spatial technique (e.g., depicting intrusion detection data

by plotting file transfer activity as a function of time and server location using a 3D surface and allowing the user to fly over the surface looking for the region with the highest mountains).

Response modality also plays a role here. By taking away buttons, handles and sticks, and moving controls into digital displays where the same buttons have different mode-dependent meanings, it puts strain on WM resources and does not allow automaticity to develop.

*Input channel and mode agility.* Particular input channels may be better suited to particular tasks. For example, there is a well recognized relationship between mode of input (visual vs. auditory) and the nature of the person's output (spatial vs. verbal), part of the concept of *stimulus-response compatibility* (Wickens & Hollands, 2000). Moreover, an implication of the work on multiple resource theory (Wickens 1984) is that capacity can be enhanced (i.e., working memory load can be reduced) when two tasks draw on different resource types. This has implications for how information is displayed to the user. Results from absolute judgment experiments indicate that using multiple stimulus dimensions can increase working memory capacity – whether this advantage is greater when multiple modalities are used has not to our knowledge been well investigated. Particular individuals may be better able to switch between different modalities as they perform tasks, an attribute we call *mode agility*. (We speculate that Generation Y may have particular advantages in this regard, due to gaming experience). The use of different display modalities would presumably be more effective for these individuals. Whether this is trainable is also not well investigated to our knowledge.

The nature of the response method is also important and must be considered in visualization. For example, by allowing users to point to a location of interest on the battlefield using gesture recognition, little demand is placed on WM (consider Colonel Johansen's idea behind "the table", this workshop). In contrast, by designing displays in such a way that users forced to define locations verbally, WM resources are diverted to an unnecessary task.

*Data compression techniques.* Most sensors collect vast quantities of data and their output needs to be summarized and co-ordinated through various *data fusion* techniques (Waltz & Llinas, 1990). We argue that such techniques can serve to reduce working memory load relative to processing data in rawer form and thereby offer a tremendous benefit to the user. For example, it has been demonstrated that sonar data are best presented to the operator after filtering and other integration techniques have been conducted.

*Intuitive presentation management.* Here we argue for visualization systems to ensure that task-relevant information is displayed. Information should correspond to the mental processing required to perform task-related activities with respect to a particular work domain. Further, we argue that intuitive displays decrease the amount of mental processing required to perform the task, reducing working memory load. One might argue that the computer can perform the necessary computation using RAM and cached storage so that the user does not use limited working memory resources to that end. For example, by re-orienting the viewpoint location on a three-dimensional (3D) geographic terrain model the user can perceive the correspondence between terrain elements on a PDA display and the forward field of view (FFOV). In contrast, the use of a fixed viewpoint can lead to left-right reversals with respect to terrain elements and could require mental rotation to determine which display object corresponds to objects in the FFOV. Porathe (2002, this workshop) describes a similar design solution for a display on a ferry bridge.

This strategy may also be enhanced through the use of intelligent agents or ontologies. For example, Zeltzer (2002, this workshop) demonstrated software that depicted planned routes through terrain given current conditions and intelligence information. The route was plotted on a 3D terrain model and could be viewed from multiple orientations.

If task-relevant information is not present at point of gaze, the user must search for it, requiring allocation of attention over available display space, and may also require command input to the computer to change

the nature of the displayed information to address task requirements. Both activities should increase working memory load, although certain display characteristics can reduce attentional demand, and highly overlearned command sequences can be issued automatically (without controlled processing). In the former case, the search for certain kinds of targets among certain kinds of distractors can lead to highly efficient search in which the number of objects on the display has no effect on search time (Wolfe, 1997). In the latter case, command sequences must be used consistently and repeatedly to produce automatic processing with training. The use of keyboard commands has been shown to be more efficient than long menu searches for this purpose (Raskin, 2000).

### DISTRIBUTED WORKING MEMORY

Consider the Turing test (Turing, 1950). If the mechanism for intelligent activity is hidden from the observer, and the observer believes it to be acting intelligently, it does not matter whether the behavior was generated by a human, a machine, or some combination thereof. In a human-computer or human-machine system, we argue that the activity of working memory can be shared between the information displayed by the interface (visual, auditory, haptic, etc) and the human operator. We call this model distributed working memory (DWM). DWM is thus conceived of as task relevant displayed information and the contents of a user's working memory.

The simplest version of the DWM model is depicted in Figure 2. Here, DWM is depicted as a stacked bar whose sum represents the information in the system. At the top of the bar is data stored in the computer or in the world via sensor information. Below that is information portrayed on a display device, including visual displays, auditory displays, or kinaesthetic information from controls such as joysticks, buttons, mice, etc. The line just below this represents the interface. Below that WM contents are represented. At the bottom is a large long-term memory store (LTM).

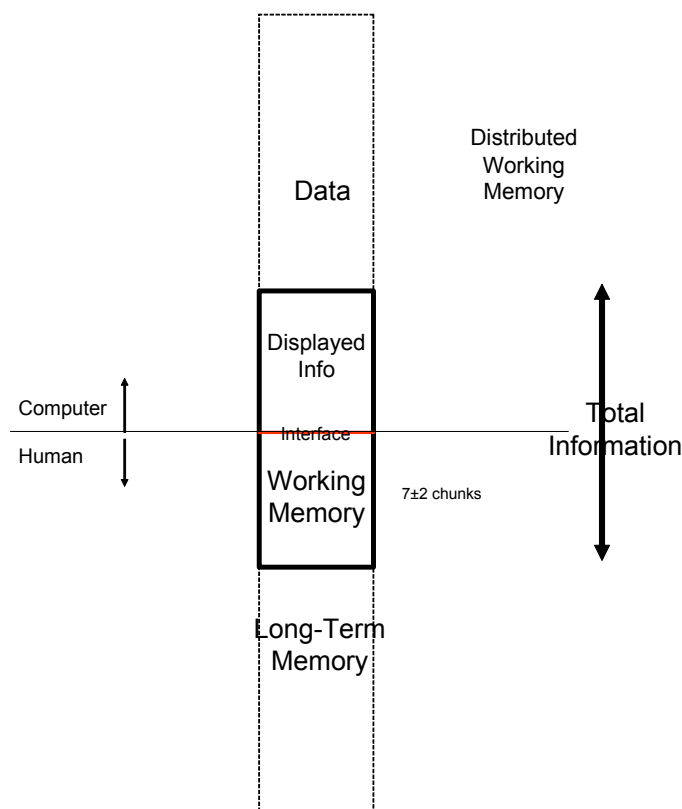

Figure 2: A Model of Distributed Working Memory (DWM).

We focus on two capacity limitations in this system, both on the human side. The first capacity limitation in this system is the attentional bottleneck. Attention is portrayed as the interface of working memory and information on the display(s). If the contents of the display are highly related to the user’s current task, as shown in Figure 2, there is little need for attentional selection or broadening. If only some display contents are related to the task, as shown in Figure 3, there is need for attentional selection. If task relevant information is not at the point of gaze, visual search is necessary, which may require attentional resources. If some information is not currently available in the display, working memory resources may be required to issue a series of commands to the computer to change the displayed information to correspond (unless the command sequence is automatized).

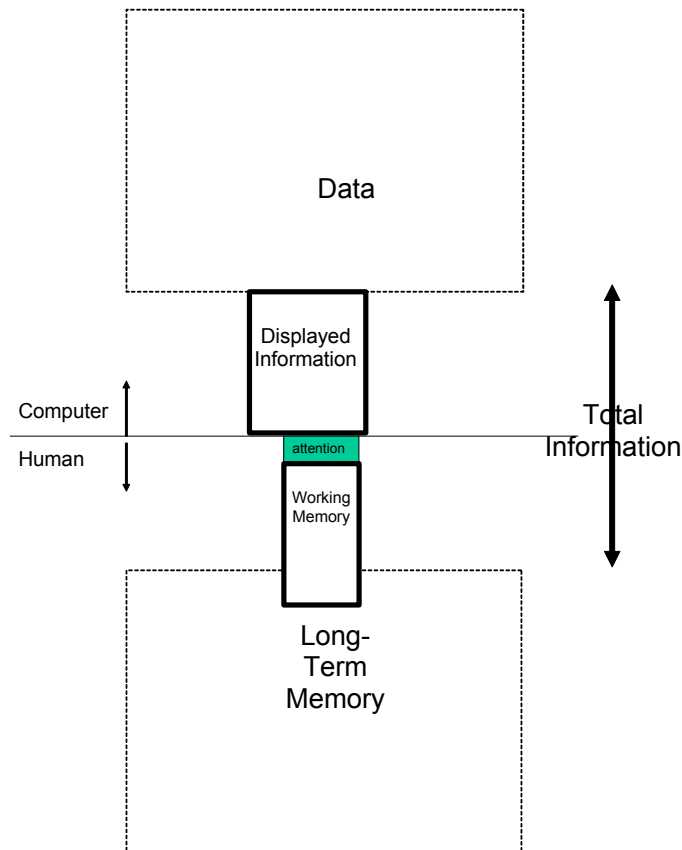

Figure 3: DWM as a Function of Changes in the Allocation of Attention.

The second capacity limitation is WM capacity. Performing a task will typically require WM resources. Units of WM capacity are chunks, to allow for domain expertise due to recoding or training. For example, a commander may be monitoring the altitudes of and distances between multiple aircraft over time using a tactical display. If the commander knows that the formation being flown specifies relatively fixed distances between aircraft, one value can be maintained in working memory rather than multiple values, freeing up WM resources. If the orientation of two tactical displays is inconsistent, forcing the observer to mentally rotate one or the other (or to make L-R reversals) this will require greater WM resources than if the two displays are aligned. If information from a surveillance aircraft indicates that all altitudes were incorrect and need to be doubled, extra computation will be required every time the observer must communicate altitude information to other members of the command team, demanding WM resources.

We assume computer memory capacity is infinite, or at least so large with respect to human WM that increases in displayed information have minimal effect on the processing capacity of the computer.

## Using Visualization to Address Human Capacity Limitations

Intuitive presentation management can be accomplished using dynamic memory allocation – that is, better designed or intelligent interfaces can perform some of the computation that otherwise the human would do, freeing up WM resources. As noted above, intelligent interfaces and ontologies that depict planned routes through terrain given current conditions and intelligence information serve this role. Effective data fusion and compression techniques can similarly be effective. Consider the system developed by Jungert et al. (2002, this workshop). Their design ensures that it is not necessary for the user to specify the precise level of sensor data to formulate a query.

Figure 4 depicts an augmentation to the model to allow for different processing resources as a function of modality. We have discussed the notion of a WM subsystem, identified a distinction between spatial and verbal processing, and noted that a verbal-spatial task combination will be performed better than a verbal-verbal or spatial-spatial. Similarly, we may consider that our mental resources are differentiable by modality (e.g., visual, auditory, tactile) or processing stage (Wickens, 1984). Another way of thinking about the shift from physical buttons handles and sticks to virtual controls described earlier is that we have shifted from taking advantage of a different (output, or late processing stage) to drawing on already overtaxed WM resources.

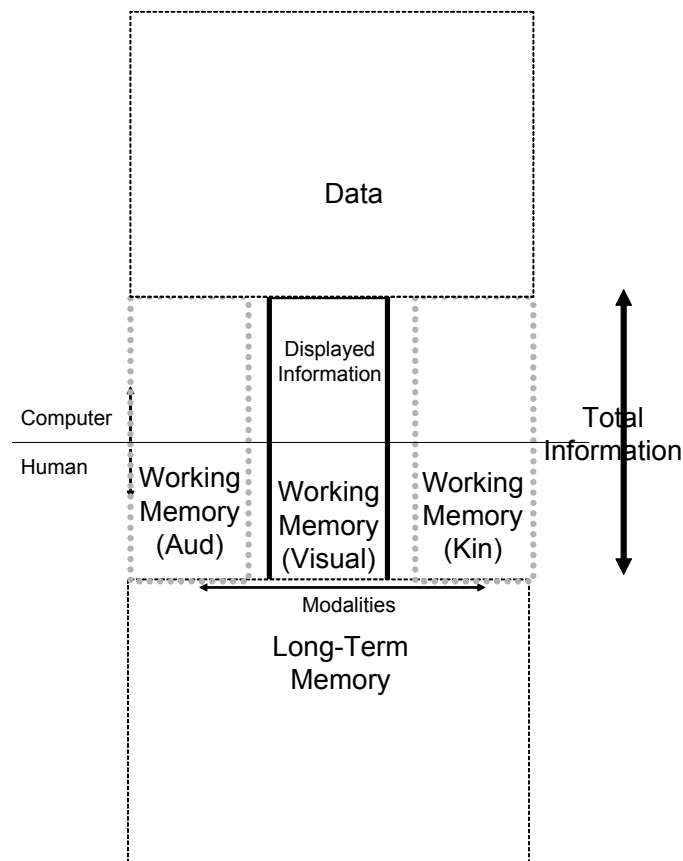

**Figure 4: DWM Modified to Incorporate Multiple Sensory Modalities.**

## DESIGN RECOMMENDATIONS

Figure 5 asserts that the capacity-enhancing aspects of any visualization design is a “system” problem. The box at the top of the figure describes components of system design that must be considered with respect to the human user, the work domain, and the task. The design problem starts with the assessment of the human role in any computer-aided system, and that is at the “Functional Allocation” step in which

the human-machine roles are defined and characterized. The second stage is to prototype the system incorporating information gained from cognitive task analysis and cognitive work analysis approaches, which allow better understanding of the user's task and work domain, respectively. The achievement of intuitive presentation management (central oval in the figure) depends on consideration of the many design-influencing factors surrounding that oval. If these components are incorporated into the design process, the result should be a system that allows the user to visualize task-relevant information in a quick, efficient way.

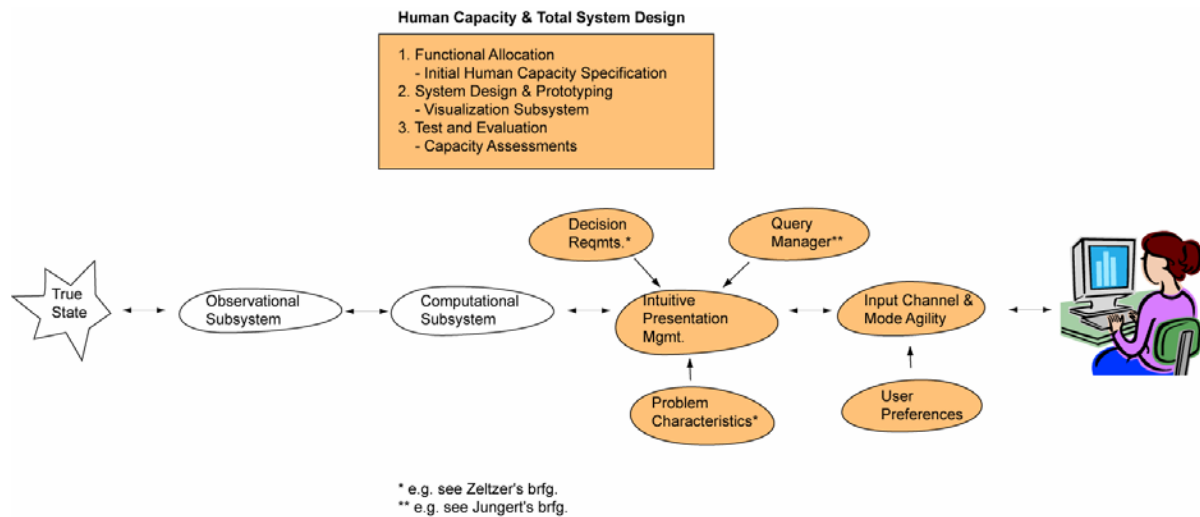

Figure 5: Capacity-Enhancing Strategies Incorporated into Design.

## RESEARCH RECOMMENDATIONS

We make the following recommendations for research topics:

- 1) Examine/explore whether capacity can be increased by using coding dimensions from different modalities
- 2) Determine how can we design systems that adapt to:
  - a) Limitations of the human--Increasing "capacity" by design: navigation engines etc.
  - b) Flow of information to correspond to situational demands
- 3) Examine whether Generation Y has increased mental capacity given their early exploration of computers.

## REFERENCES

Baddeley, A.D. (1995). *Working Memory*. Oxford, England: Clarendon.

Baddeley, A.D. (1995). Working Memory. In M.S. Gazzaniga et al. (Eds.), *The Cognitive Neurosciences* (pp. 755-784). Cambridge, MA: MIT Press.

Chase, W.G., & Simon, H.A. (1973). The Mind's Eye in Chess. In W.G. Chase (Ed.), *Visual Information Processing*. New York: Academic Press.

Egeth, H. & Pachella, R. (1969). Multidimensional Stimulus Identification. *Perception & Psychophysics*, 5, 341-346.

## Using Visualization to Address Human Capacity Limitations

---

Ericsson, K.A., & Kintsch, W. (1995). Long-Term Working Memory. *Psychological Review*, 102, 211-245.

Klein, G. (1989). Recognition-Primed Decision Making. *Advances in Man-Machine Systems Research*, 5, 47-92.

Miller, G.A. (1956). The Magical Number Seven Plus or Minus Two: Some Limits on Our Capacity for Processing Information. *Psychological Review*, 63, 81-97.

Muller, H.J., & Rabbitt, P.M. (1989). Reflexive and Voluntary Orienting of Visual Attention: Time Course of Activation and Resistance to Interruption. *Journal of Experimental Psychology: Human Perception & Performance*, 15, 315-330.

Pashler, H.E. (1998). *The Psychology of Attention*. Cambridge, MA: MIT Press.

Orasanu, J. (1997). Stress and Naturalistic Decision Making: Strengthening the Weak Links. In R. Flin, E. Salas, M. Strub, & L. Martin (Eds.), *Decision Making Under Stress: Emerging Themes and Applications* (pp. 43-66). Brookfield, VT: Ashgate.

Raskin, J. (2000). *The Humane Interface: New Directions for Designing Interactive Systems*. Boston: Addison-Wesley.

Schneider, W., & Shiffrin, R. M. (1977). Controlled and Automatic Human Information Processing I: Detection, Search, and Attention. *Psychological Review*, 84, 1-66.

Treisman, A.M. and Gelade, G. (1980). A Feature-Integration Theory of Attention. *Cognitive Psychology*, 12, 97-136.

Turing, A.M. (1950). Computing machinery and intelligence. *Mind*, 59, 433-460.

Waltz, E.L., & Llinas, J. (1990). *Multisensor Data Fusion*. Artech House Radar/Electronic Warfare Library.

Wickens, C.D. (1984). Processing Resources in Attention. In R. Parasuraman & R. Davies (Eds.), *Varieties of Attention* (pp. 63-101) New York: Academic Press.

Wickens, C.D., & Hollands, J.G. (2000). *Engineering Psychology and Human Performance* (3rd Ed.). Upper Saddle River, NJ: Prentice-Hall.

Wolfe, J.M. (1997). Visual Search. In H. Pashler (Ed.), *Attention* (pp.13-73). Hove, England: Psychology Press/Erlbaum.

Woodin, M.E., & Heil, J. (1996). Skilled Motor Performance and Working Memory in Rowers: Body Patterns and Spatial Positions. *Quarterly Journal of Experimental Psychology*, 49A, 357-378.

## SYMPOSIA DISCUSSION – SYNDICATE 3

**Comment:**

With expertise and learning, people can develop long-term memory that can function as working memory.

**Comment:**

It would be interesting to integrate the findings of vast numbers of small experiments that have been done to compile the evidence that exists in areas such as human cognitive architecture, as well as parallel and motor human possessors.

**Question:**

Research that suggests that different people think in different ways, should the same modalities be presented to every user, or can you exploit the capabilities of the individual?

**Response:**

Research into the system learning about the capabilities of the user and knowledge the user's preferences and abilities and provide info accordingly.

## Using Visualization to Address Human Capacity Limitations

---



*Using Visualization to Address  
Human Capacity Limitations*

Syndicate 3

IST-036/RWS-005

Halden Norway

Sept. 10-14 2002

# Problem Statement

- Problem: how can we use visualization to overcome human capacity limitations

# Findings

- Background: Defining capacity
  - Updating  $7 \pm 2$  chunks
  - Effect of combination of modalities (vision, audition, haptic, kinesthetic)
- Generation “I”: pre-trained
- Better displays; displays that don’t require mental transformation
- “Don’t give me symbology”
- Dataflood problem
- Recognition-primed decision making
- Intelligence: navigation engines, agents, ontology
- Teams and collaboration: Trade-off between comm and vis

Working Memory Load

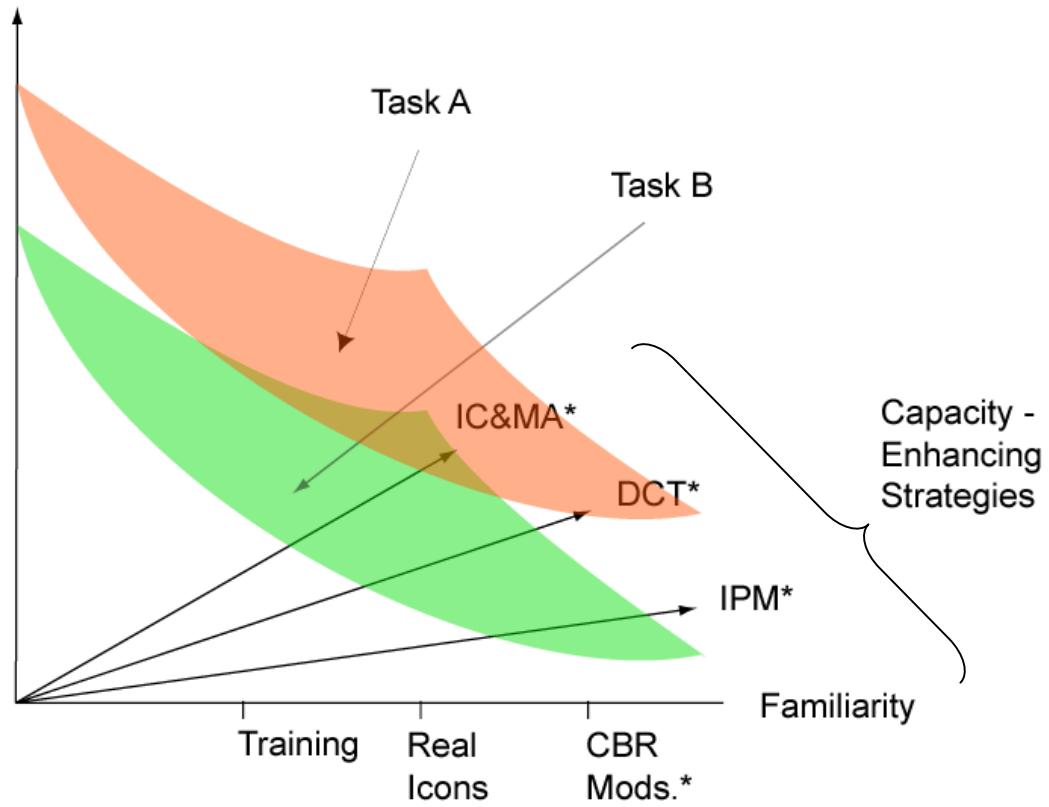

\* Input Channel & Mode Agility  
Data Compression Techniques  
Intuitive Presentation Management  
Case Based Reasoning

### Human Capacity & Total System Design

1. Functional Allocation
  - Initial Human Capacity Specification
2. System Design & Prototyping
  - Visualization Subsystem
3. Test and Evaluation
  - Capacity Assessments

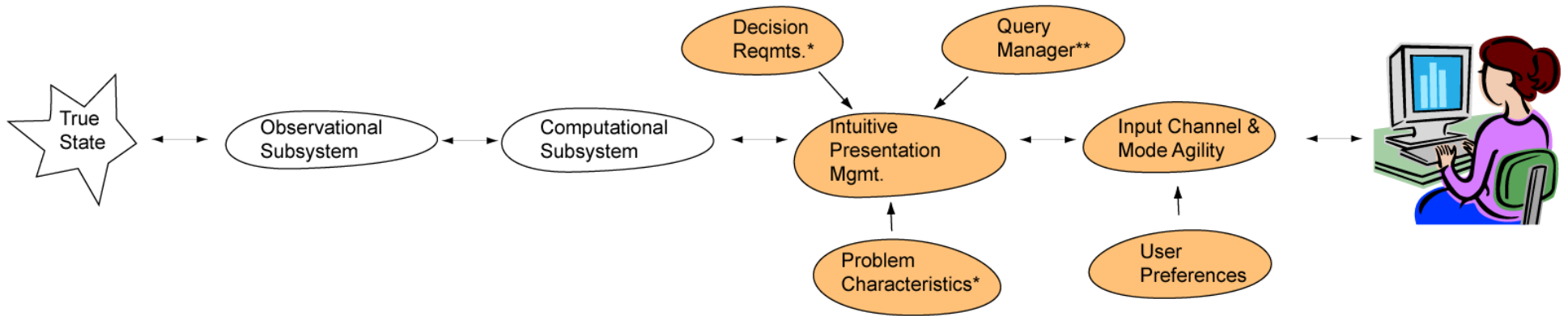

\* e.g. see Zeltzer's brfg.

\*\* e.g. see Jungert's brfg.

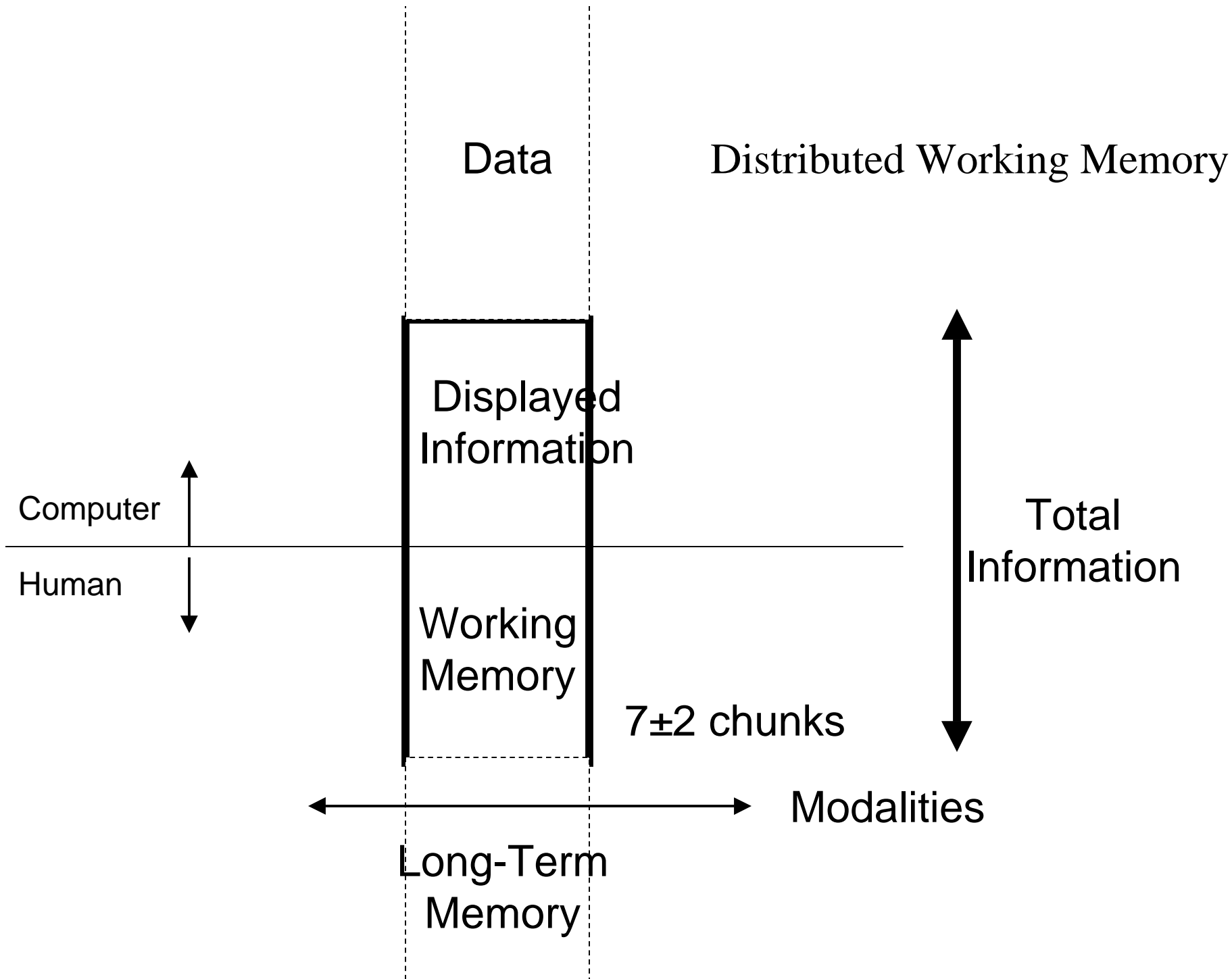

# Research Recommendations

- Examine/explore whether capacity can be increased by using coding dimensions from different modalities
- How can we design systems that adapt to:
  - Limitations of the human--Increasing “capacity” by design: navigation engines etc.
  - Flow of information to correspond to situational demands
- Examine whether Generation “I” has increased mental capacity given their early exploration of computers