



## **Simulation of Heating of an Oil-Cooled Insulated Gate Bipolar Transistors Converter Model**

**by Gregory K. Ovrebo**

---

**ARL-MR-599**

**October 2004**

## **NOTICES**

### **Disclaimers**

The findings in this report are not to be construed as an official Department of the Army position unless so designated by other authorized documents.

Citation of manufacturer's or trade names does not constitute an official endorsement or approval of the use thereof.

Destroy this report when it is no longer needed. Do not return it to the originator.

**Army Research Laboratory**

Adelphi, MD 20783-1197

---

---

**ARL-MR-599**

**October 2004**

---

---

**Simulation of Heating of an Oil-Cooled Insulated Gate  
Bipolar Transistors Converter Model**

**Gregory K. Ovrebo**  
**Sensors and Electron Devices Directorate, ARL**

---

---

**Approved for public release; distribution unlimited.**

---

---

**REPORT DOCUMENTATION PAGE**

*Form Approved*  
*OMB No. 0704-0188*

Public reporting burden for this collection of information is estimated to average 1 hour per response, including the time for reviewing instructions, searching existing data sources, gathering and maintaining the data needed, and completing and reviewing the collection information. Send comments regarding this burden estimate or any other aspect of this collection of information, including suggestions for reducing the burden, to Department of Defense, Washington Headquarters Services, Directorate for Information Operations and Reports (0704-0188), 1215 Jefferson Davis Highway, Suite 1204, Arlington, VA 22202-4302. Respondents should be aware that notwithstanding any other provision of law, no person shall be subject to any penalty for failing to comply with a collection of information if it does not display a currently valid OMB control number.

**PLEASE DO NOT RETURN YOUR FORM TO THE ABOVE ADDRESS.**

<b>1. REPORT DATE (DD-MM-YYYY)</b> October 2004		<b>2. REPORT TYPE</b> Interim		<b>3. DATES COVERED (From - To)</b> January to April 2004	
<b>4. TITLE AND SUBTITLE</b> Simulation of Heating of an Oil-Cooled Insulated Gate Bipolar Transistors Converter Model				<b>5a. CONTRACT NUMBER</b>	
				<b>5b. GRANT NUMBER</b>	
				<b>5c. PROGRAM ELEMENT NUMBER</b>	
<b>6. AUTHOR(S)</b> Gregory K. Ovrebo				<b>5d. PROJECT NUMBER</b>	
				<b>5e. TASK NUMBER</b>	
				<b>5f. WORK UNIT NUMBER</b>	
<b>7. PERFORMING ORGANIZATION NAME(S) AND ADDRESS(ES)</b> U.S. Army Research Laboratory ATTN: AMSRD-ARL-SE-DP 2800 Powder Mill Road Adelphi, MD 20783-1197				<b>8. PERFORMING ORGANIZATION REPORT NUMBER</b>  ARL-MR-599	
<b>9. SPONSORING/MONITORING AGENCY NAME(S) AND ADDRESS(ES)</b> U.S. Army Research Laboratory 2800 Powder Mill Road Adelphi, MD 20783-1197				<b>10. SPONSOR/MONITOR'S ACRONYM(S)</b>	
				<b>11. SPONSOR/MONITOR'S REPORT NUMBER(S)</b>	
<b>12. DISTRIBUTION/AVAILABILITY STATEMENT</b> Approved for public release; distribution unlimited.					
<b>13. SUPPLEMENTARY NOTES</b>					
<b>14. ABSTRACT</b> I used SolidWorks, a three-dimensional modeling software, and FloWorks, a fluid dynamics analysis tool, to simulate oil flow and heat transfer in a heat sink structure attached to three insulated gate bipolar transistors. My objective was to estimate the cooling properties of the oil-cooled heat sink during a range of operating conditions. I calculated steady state temperatures of the heat sink and plotted heat contours on its surface. I also calculated the temperature, pressure, and velocity of the oil as it flowed through the heat sink.					
<b>15. SUBJECT TERMS</b> Simulation, heat transfer, IGBT, heat sink, SolidWorks					
<b>16. SECURITY CLASSIFICATION OF:</b>			<b>17. LIMITATION OF ABSTRACT</b> UL	<b>18. NUMBER OF PAGES</b> 18	<b>19a. NAME OF RESPONSIBLE PERSON</b> Gregory K. Ovrebo
<b>a. REPORT</b> Unclassified	<b>b. ABSTRACT</b> Unclassified	<b>c. THIS PAGE</b> Unclassified			<b>19b. TELEPHONE NUMBER (Include area code)</b> (301) 394-0814

---

## Contents

---

<b>List of Figures</b>	<b>iv</b>
<b>List of Tables</b>	<b>iv</b>
<b>1. Introduction</b>	<b>1</b>
<b>2. IGBT Converter Module</b>	<b>1</b>
<b>3. FloWorks Simulation</b>	<b>4</b>
3.1 Surface Temperature .....	4
3.2 Oil Temperature .....	7
3.3 Oil Pressure .....	8
3.4 Oil Velocity .....	8
<b>4. Conclusions</b>	<b>10</b>
<b>Distribution List</b>	<b>11</b>

---

## List of Figures

---

Figure 1. IGBT converter module, as rendered in SolidWorks. ....	1
Figure 2. Lower plate of heat sink, showing inserts that increase turbulence in oil flow.....	2
Figure 3. Middle heat sink plate, including oil inlet and outlet ports. ....	3
Figure 4. Top plate of heat sink. ....	3
Figure 5. Temperature contours from simulation of 50 °C oil flowing at 2 gpm. ....	5
Figure 6. Temperature contours from simulation of 80 °C oil flowing at 3 gpm. ....	5
Figure 7. Temperature contours from simulation of 80 °C oil flowing at 2 gpm. ....	6
Figure 8. Temperature contours from simulation of 50 °C oil flowing at 3 gpm. ....	6
Figure 9. Oil temperature as it flows through the heat sink, for the case of 80 °C oil flowing at 2 gpm. ....	7
Figure 10. Oil pressure in the heat sink, for 50 °C oil flowing at 3 gpm.....	8
Figure 11. Oil velocity through the heat sink with a 2-gpm flow.....	9
Figure 12. Oil velocity through the heat sink with a 3-gpm flow.....	10

---

## List of Tables

---

Table 1. Thermal properties of Castrol 399 oil.....	4
Table 2. Maximum temperature and temperature differential for FloWorks simulations.....	7
Table 3. Maximum oil pressure for FloWorks simulations. ....	8
Table 4. Maximum oil velocity for FloWorks simulations.....	9

---

## 1. Introduction

---

SolidWorks modeling software can render three-dimensional representations of solid objects and can perform an engineering analysis of those objects. Among its analytical tools is FloWorks, a computational fluid dynamics code used for fluid flow and thermal transfer simulation. We used FloWorks to simulate heat transfer and predict steady state temperature in a power converter module being developed by the U.S. Army Research Laboratory (ARL).

---

## 2. IGBT Converter Module

---

The power converter module we are simulating uses three insulated gate bipolar transistors (IGBT) side by side on a printed circuit board. Each IGBT produces approximately 20 W of heat in operation. The module will be cooled by a heat sink mounted on the IGBTs and fluid circulating through the heat sink. Modules like this one will be used in automotive applications so that engine oil is available as a cooling fluid. Figure 1 is a rendering of the converter module as modeled in SolidWorks; the three IGBTs lie sandwiched between the printed circuit board and the rectangular heat sink. This assembly, including the heat sink, was designed by Don Porschet of ARL.

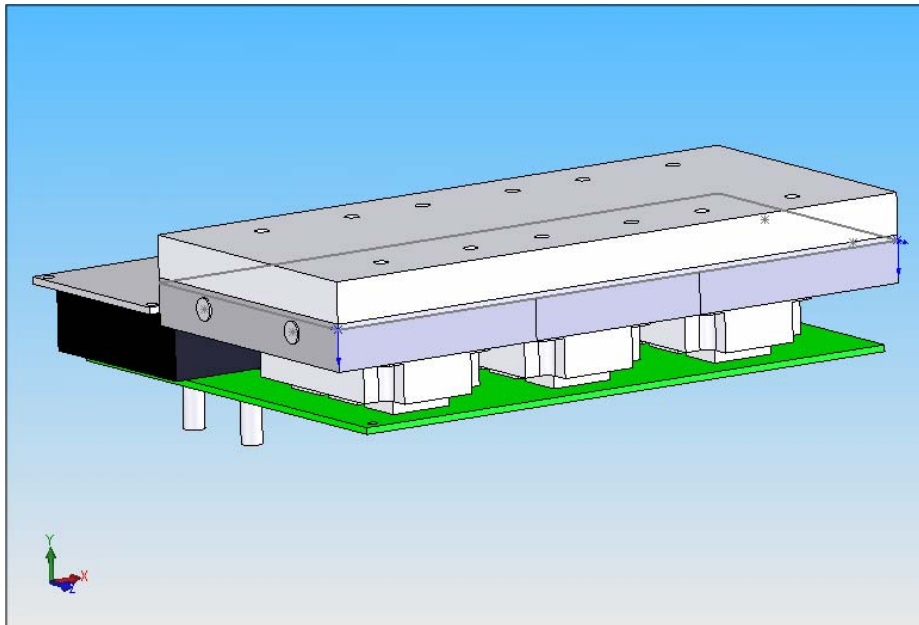

Figure 1. IGBT converter module, as rendered in SolidWorks.

The goal of our simulations will be to determine the steady state temperature of the converter module, taking into account the heat produced by the IGBTs and the convective heat transfer provided by the circulating oil. We wish to keep module temperatures below 125 °C to prevent heat-induced damage in our silicon components, and we need to determine whether the heat sink design is adequate to accomplish this. Our simulations included four combinations of oil volume flow and oil temperature as parameters in the calculation of the module temperature.

The heat sink attached to the IGBTs is made of oxygen-free copper. It has two inlet ports and two outlet ports for the motor oil. A chamber is machined into the heat sink below each IGBT and oil is pumped into the chamber from either end. In the chamber, oil must pass through an array of thin vertical spines that promote turbulent flow and improve heat transfer from the heat sink to the oil. Oil exits the chamber through a hole in the top of the chamber and flows through a channel in the top of the heat sink to the outlet ports. Figure 2 shows a rendering of the bottom portion of the heat sink, with the “turbulator inserts” which increase turbulent flow through the chambers. Figure 3 shows the middle plate of the heat sink, with inlet and outlet ports and chambers. Figure 4 shows the bottom plate of the heat sink, with channeling for the outlet ports.

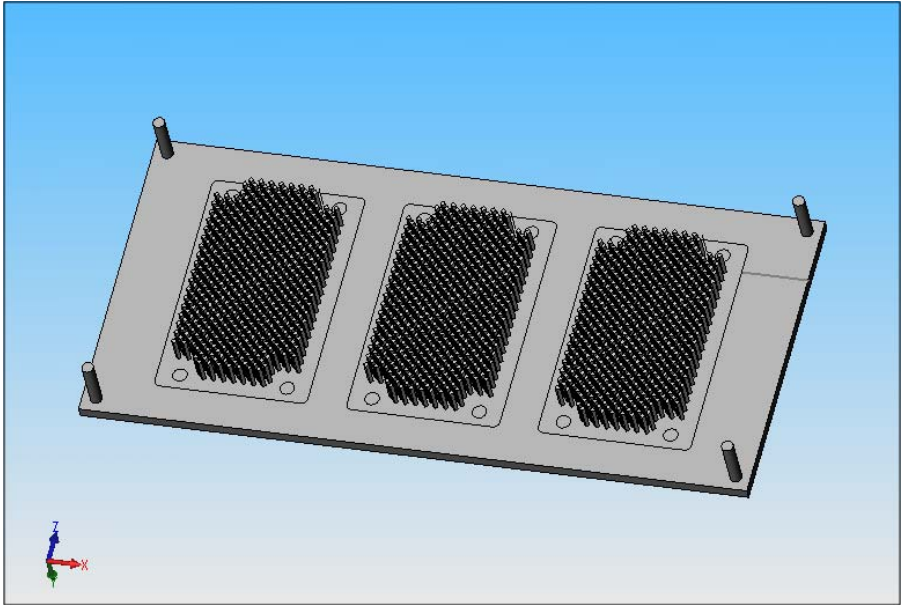

Figure 2. Lower plate of heat sink, showing inserts that increase turbulence in oil flow.

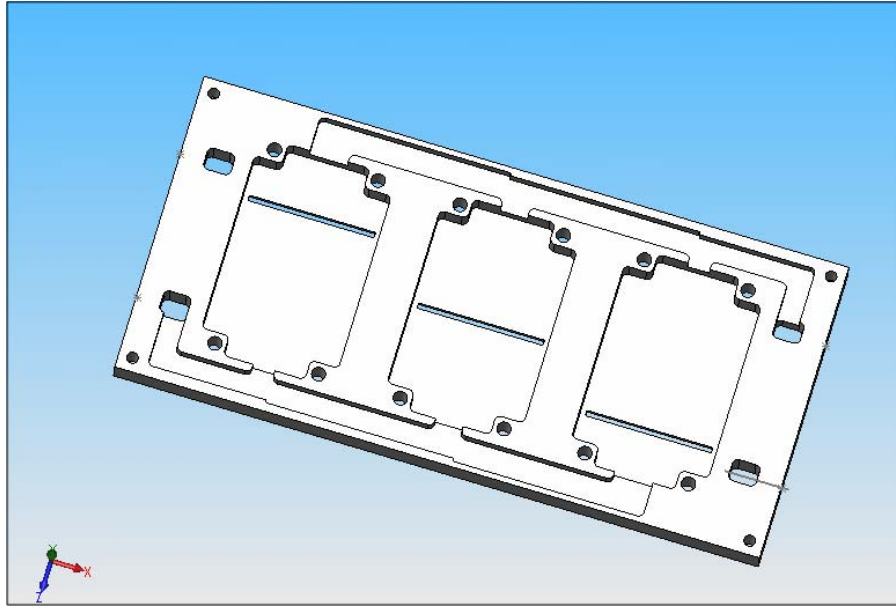

Figure 3. Middle heat sink plate, including oil inlet and outlet ports.

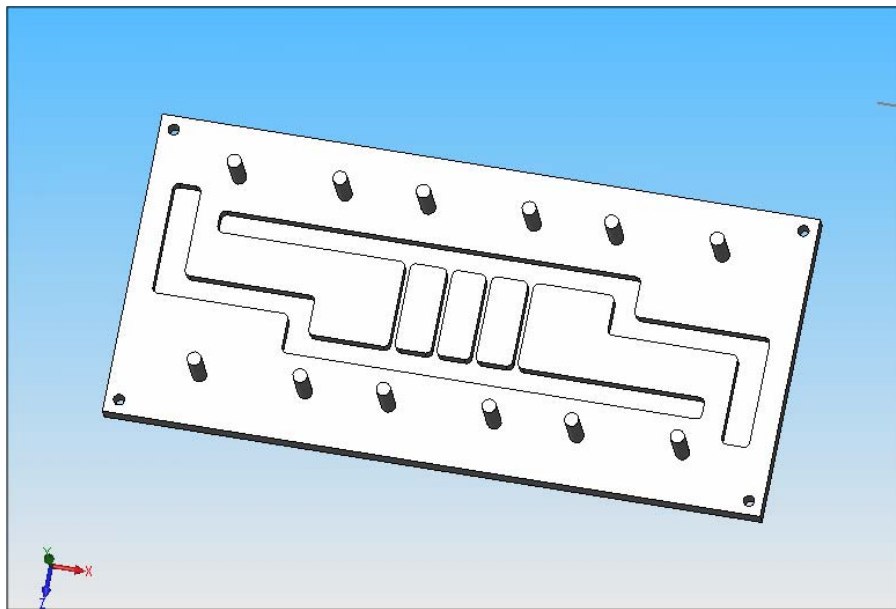

Figure 4. Top plate of heat sink.

The particular oil used in our simulation was Castrol 399. The physical properties of this oil were included in a materials database accessed by FloWorks. The properties used by the fluid dynamics simulation were density, dynamic viscosity, specific heat, and thermal conductivity. The values used in this simulation are listed in table 1.

Table 1. Thermal properties of Castrol 399 oil.

Density (kg/m <sup>3</sup> )	
950	
Dynamic Viscosity (Pascal·s)	Temperature (K)
120.65	222.15
0.1184	313.15
0.0303	373.15
Thermal Conductivity (W/(m·K))	Temperature (K)
0.151	310.93
0.144	477.59
Specific Heat (J/(kg·K))	Temperature (K)
1858	310.93
2063	366.48
2230	422.04
2364	477.59

---

### 3. FloWorks Simulation

---

Simulation in FloWorks requires specification of boundary conditions, which in this case are the temperature of the oil at the inlet port and the rate of flow in gallons per minute (gpm). The initial configuration of the FloWorks simulation was done by Tim Barker of TriMech Solutions. After we discovered that the properties of the Castrol 399 oil (kinematic viscosities, specific heat, and thermal conductivity) used in this configuration were incorrect, we made corrections and performed our own simulations.

We chose combinations of two different oil temperatures and two different flow rates, for a total of four simulation configurations. Oil temperature was specified at either 50 °C or 80 °C, and flow rate at each inlet port was specified at either 2 gpm or 3 gpm. Pressure at the outlet ports was specified at atmospheric pressure, 14 psi.

Individual simulations required about 12 hours for completion. The fine structure in the heat sink chambers requires FloWorks to set a finer mesh in those areas; a finer mesh means more computation time.

#### 3.1 Surface Temperature

Figures 5 through 8 show contour plots of surface temperatures on the IGBTs and the heat sink to which they are attached. The printed circuit board and capacitor have been hidden to simplify the computation.

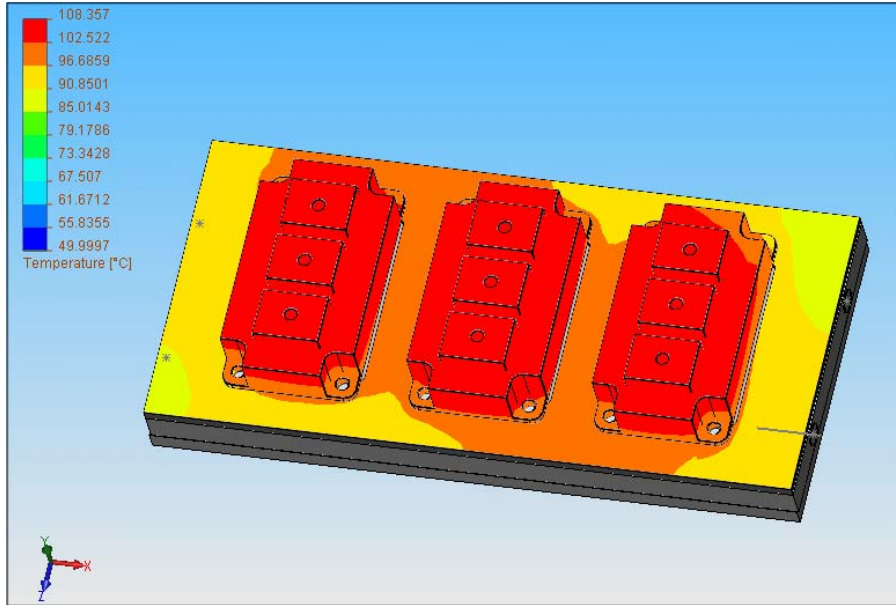

Figure 5. Temperature contours from simulation of 50 °C oil flowing at 2 gpm.

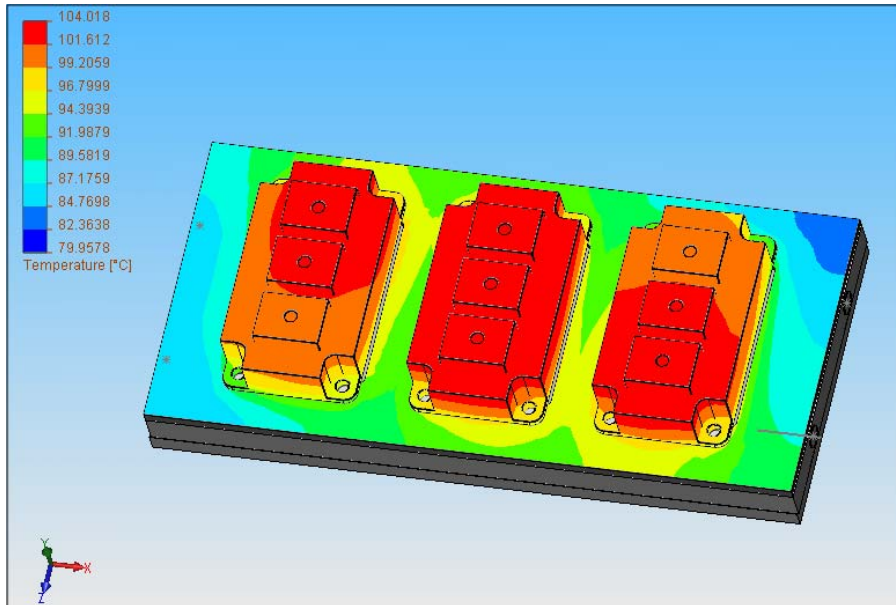

Figure 6. Temperature contours from simulation of 80 °C oil flowing at 3 gpm.

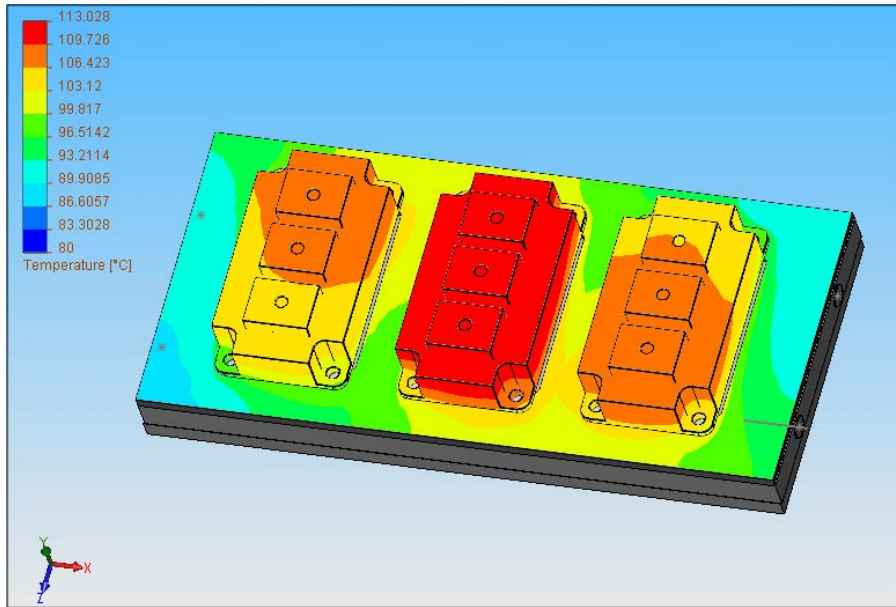

Figure 7. Temperature contours from simulation of 80 °C oil flowing at 2 gpm.

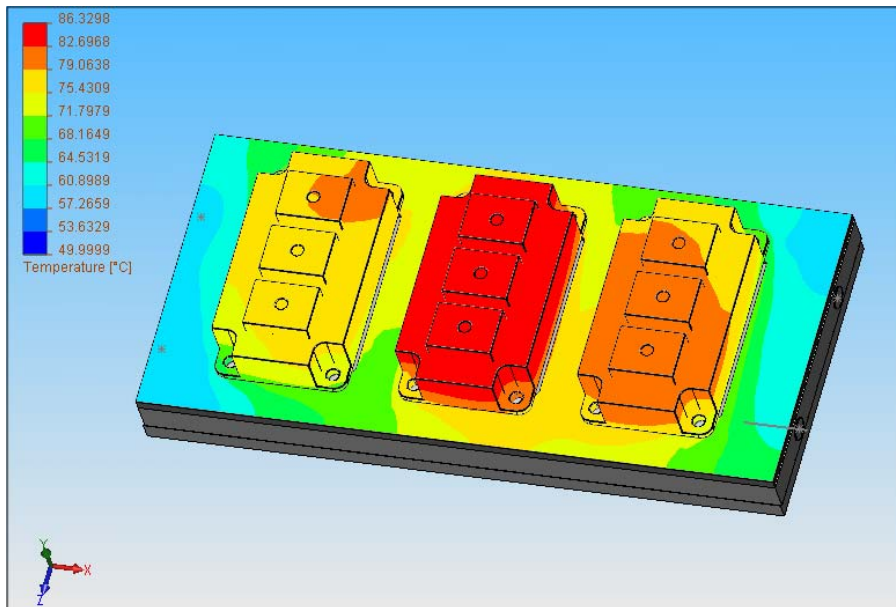

Figure 8. Temperature contours from simulation of 50 °C oil flowing at 3 gpm.

Table 2 summarizes the maximum temperature and the temperature differential (the difference between the oil temperature and maximum module temperature) calculated for each of the four cases.

Table 2. Maximum temperature and temperature differential for FloWorks simulations.

Oil Temperature (°C)	Flow Rate (gpm)	Maximum Temperature (°C)	Temperature Differential (°C)
50	2	108	58
50	3	86	36
80	2	113	33
80	3	104	24

The highest temperature reached anywhere on the surface of the module, in any simulation, is 113 °C. As we would expect, this result came from the configuration with the warmest oil and the lowest coolant flow. Similarly, the case with the lowest maximum temperature was the one with the lowest oil temperature and the highest flow rate. Higher flow rates lowered the temperature differential, but the effect was modest with 80 °C oil. Because the heat sink has one inlet port at each end, the center of the module has the highest temperature; areas near the inlet ports, at the lower left and upper right of the heat sink, have the lowest temperature.

### 3.2 Oil Temperature

Figure 9 shows trajectories for the oil passing from inlet to outlet; the color indicates the temperature. The temperature of the oil changes little as it passes through the heat sink, except for a few hot spots. This particular plot is for 80 °C oil flowing at 2 gpm, but plots for the other cases are very similar.

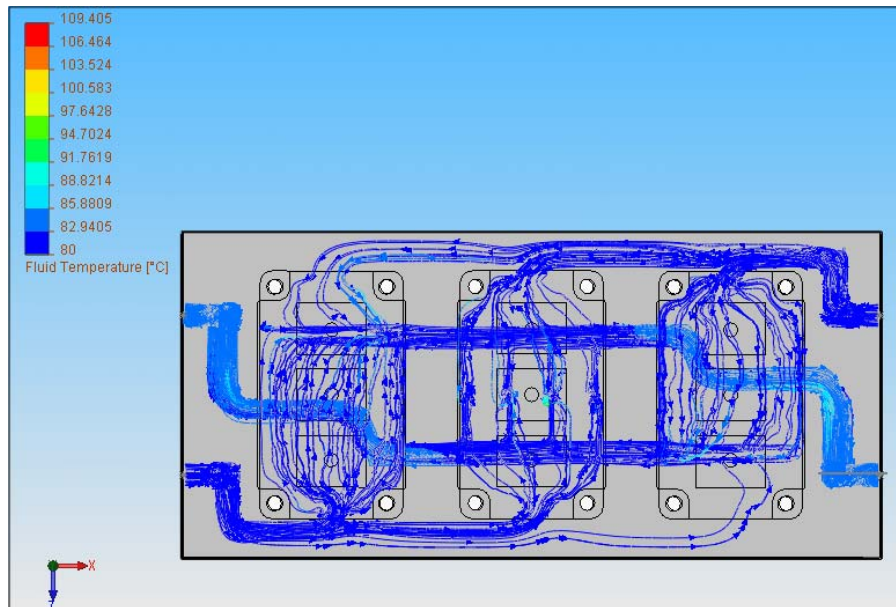

Figure 9. Oil temperature as it flows through the heat sink, for the case of 80 °C oil flowing at 2 gpm.

### 3.3 Oil Pressure

Trajectory plots can also be used to illustrate the pressure drop between inlet and outlet ports. Figure 10 shows trajectories for the oil as it flows through the heat sink, with the color indicating the oil pressure at different points in the flow. This figure corresponds to the case of 50 °C oil flowing at 3 gpm. Table 3 summarizes the results of oil pressure calculations for the four simulations.

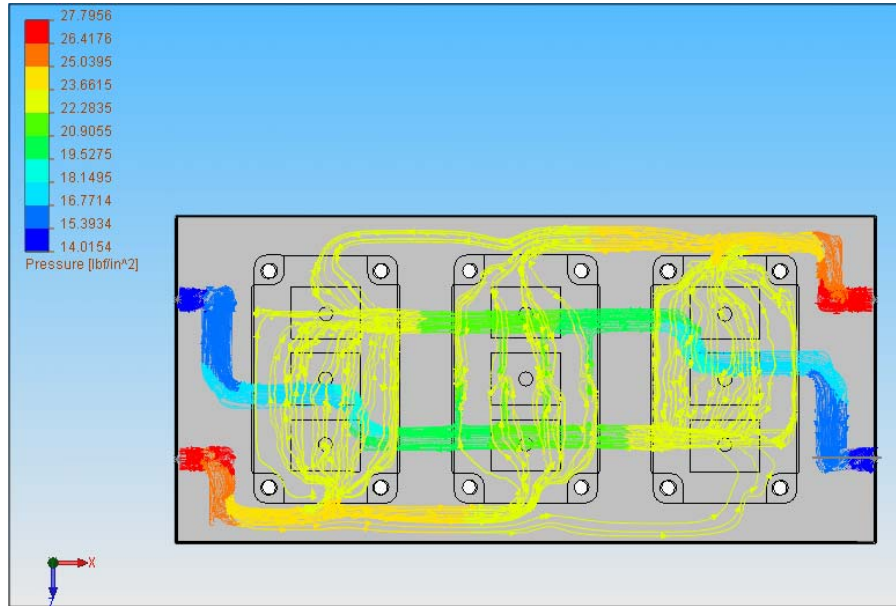

Figure 10. Oil pressure in the heat sink, for 50 °C oil flowing at 3 gpm.

Table 3. Maximum oil pressure for FloWorks simulations.

Oil Temperature (°C)	Flow Rate (gpm)	Maximum Oil Pressure (psi)
50	2	22.3
50	3	27.8
80	2	19.7
80	3	23.7

### 3.4 Oil Velocity

The FloWorks simulation also calculates the velocity of the oil as it passes through the heat sink. Table 4 summarizes the calculated maximum oil velocity in the heat sink channels for each of

the four simulation cases. Figure 11 shows fluid trajectories through the heat sink, color coded to chart changes in fluid velocity. This plot is for the 2-gpm flow case. Notice how the oil velocity is reduced as the oil emerges from the narrow inlet passage and enters the wider cavities below the IGBT. Inlet ports are at the lower left and upper right of these diagrams.

Table 4. Maximum oil velocity for FloWorks simulations.

Oil Temperature (°C)	Flow Rate (gpm)	Maximum Oil Velocity (m/s)
50	2	4.1
50	3	6.1
80	2	4.0
80	3	5.9

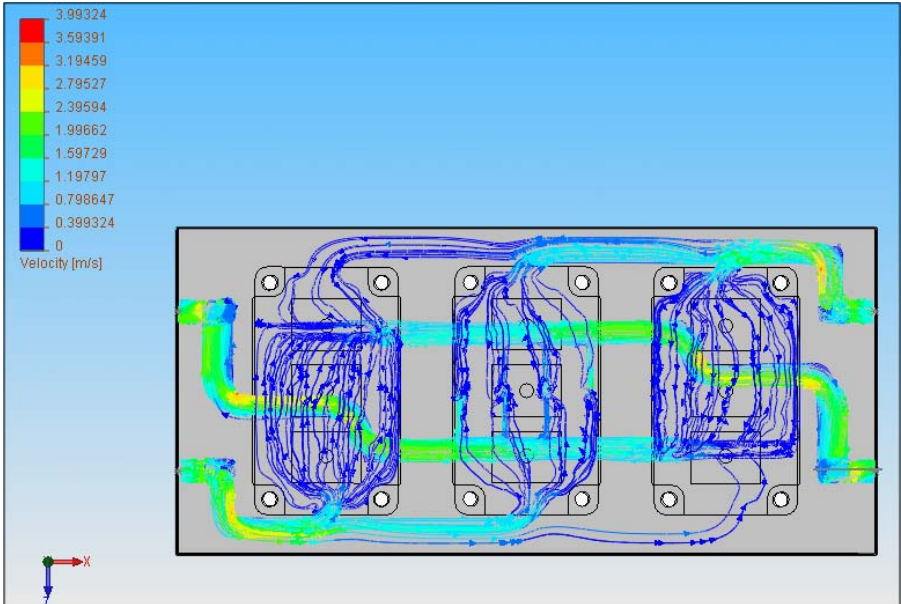

Figure 11. Oil velocity through the heat sink with a 2-gpm flow.

Figure 12 shows a similar plot for the case of a 3-gpm flow. Maximum velocity is about 50% higher in the case of 3 gpm than for the 2-gpm oil flow.

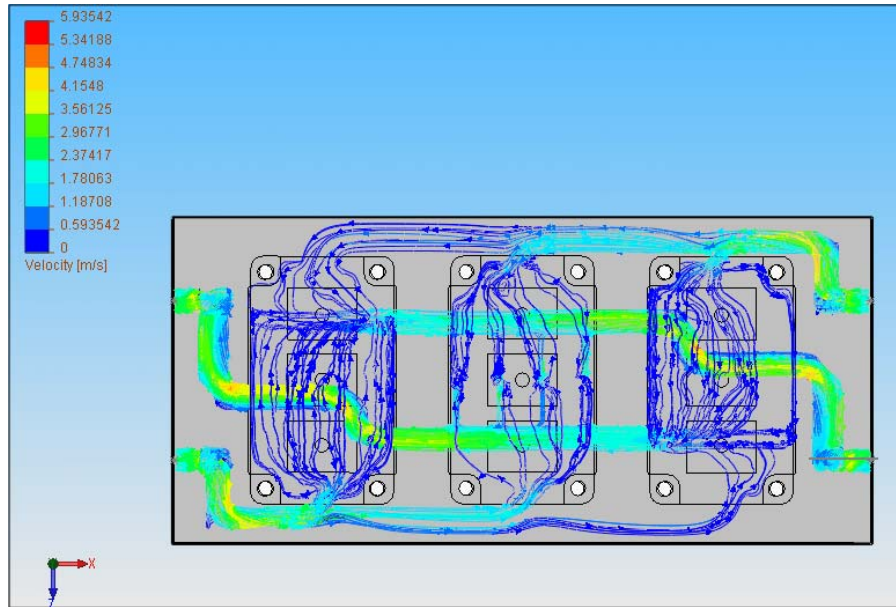

Figure 12. Oil velocity through the heat sink with a 3-gpm flow.

---

## 4. Conclusions

---

Simulations indicate that we can achieve our goal of keeping module temperatures below approximately 125 °C and preventing heat-induced damage in the silicon electronic components. Our worst case simulation was a system with 80 °C oil flowing at 2 gpm, assuming that each of the IGBTs generates 20 W of heat. This simulation yielded a maximum surface temperature of 113 °C. Other simulations, with lower oil temperatures or higher flow rates, yielded lower module temperatures.

---

## Distribution List

---

ADMNSTR  
DEFNS TECHL INFO CTR  
ATTN DTIC-OCP (ELECTRONIC COPY)  
8725 JOHN J KINGMAN RD STE 0944  
FT BELVOIR VA 22060-6218

US MILITARY ACDMY  
MATHEMATICAL SCI CTR OF EXCELLENCE  
ATTN LTC T RUGENSTEIN  
THAYER HALL RM 226C  
WEST POINT NY 10996-1786

PALISADES INST FOR RSRCH SVC INC  
ATTN E CARR  
1745 JEFFERSON DAVIS HWY STE 500  
ARLINGTON VA 22202-3402

DIRECTOR  
US ARMY RSRCH LAB  
ATTN AMSRD-ARL-RO-EN W D BACH  
PO BOX 12211  
RESEARCH TRIANGLE PARK NC 27709

US ARMY RSRCH LAB  
ATTN AMSRD-ARL-CI-OK-T TECHL PUB (2 COPIES)  
ATTN AMSRD-ARL-CI-OK-TL TECHL LIB (2 COPIES)  
ATTN AMSRD-ARL-D J M MILLER  
ATTN AMSRD-ARL-SE-DP B GEIL  
ATTN AMSRD-ARL-SE-DP C SCOZZIE  
ATTN AMSRD-ARL-SE-DP D PORSCHET  
ATTN AMSRD-ARL-SE-DP G OVREBO (10 COPIES)  
ATTN AMSRD-ARL-SE-DP J HOPKINS  
ATTN AMSRD-ARL-SE-DP W TIPTON  
ATTN IMNE-AD-IM-DR MAIL & RECORDS MGMT  
ADELPHI MD 20783-1197

INTENTIONALLY LEFT BLANK.