



**Development and Evaluation of a Surface-Mount,
High-G Accelerometer**

by Philip J. Peregino II and Edward Bukowski

ARL-TR-3331

September 2004

NOTICES

Disclaimers

The findings in this report are not to be construed as an official Department of the Army position unless so designated by other authorized documents.

Citation of manufacturer's or trade names does not constitute an official endorsement or approval of the use thereof.

Destroy this report when it is no longer needed. Do not return it to the originator.

Army Research Laboratory

Aberdeen Proving Ground, MD 21005-5066

ARL-TR-3331

September 2004

Development and Evaluation of a Surface-Mount, High-G Accelerometer

**Philip J. Peregino II and Edward Bukowski
Weapons and Materials Research Directorate, ARL**

REPORT DOCUMENTATION PAGE			<i>Form Approved</i> OMB No. 0704-0188	
Public reporting burden for this collection of information is estimated to average 1 hour per response, including the time for reviewing instructions, searching existing data sources, gathering and maintaining the data needed, and completing and reviewing the collection information. Send comments regarding this burden estimate or any other aspect of this collection of information, including suggestions for reducing the burden, to Department of Defense, Washington Headquarters Services, Directorate for Information Operations and Reports (0704-0188), 1215 Jefferson Davis Highway, Suite 1204, Arlington, VA 22202-4302. Respondents should be aware that notwithstanding any other provision of law, no person shall be subject to any penalty for failing to comply with a collection of information if it does not display a currently valid OMB control number. PLEASE DO NOT RETURN YOUR FORM TO THE ABOVE ADDRESS.				
1. REPORT DATE (DD-MM-YYYY) September 2004		2. REPORT TYPE Final		3. DATES COVERED (From - To) January 2002–July 2004
4. TITLE AND SUBTITLE Development and Evaluation of a Surface-Mount, High-G Accelerometer			5a. CONTRACT NUMBER	
			5b. GRANT NUMBER	
			5c. PROGRAM ELEMENT NUMBER	
6. AUTHOR(S) Philip J. Peregino II and Edward Bukowski			5d. PROJECT NUMBER 1L1622618.H80	
			5e. TASK NUMBER	
			5f. WORK UNIT NUMBER	
7. PERFORMING ORGANIZATION NAME(S) AND ADDRESS(ES) U.S. Army Research Laboratory ATTN: AMSRD-ARL-WM-BA Aberdeen Proving Ground, MD 21005-5066			8. PERFORMING ORGANIZATION REPORT NUMBER ARL-TR-3331	
9. SPONSORING/MONITORING AGENCY NAME(S) AND ADDRESS(ES)			10. SPONSOR/MONITOR'S ACRONYM(S)	
			11. SPONSOR/MONITOR'S REPORT NUMBER(S)	
12. DISTRIBUTION/AVAILABILITY STATEMENT Approved for public release; distribution is unlimited.				
13. SUPPLEMENTARY NOTES				
14. ABSTRACT The Endevco model 7270A high-g accelerometer has been used successfully in numerous flight tests at the U.S. Army Research Laboratory. The accelerometer is available in ranges as low as 6,000 g's and up to 200,000 g's, so they can be used in a variety of situations to measure setback, setforward, and balloting in artillery rounds, mortars, and tank projectiles, to name a few. However, one of the disadvantages of the model 7270A is its physical size. In the area of die level and surface mount components, the 7270A is relatively large. The sensing element is packaged inside a metal case with screw holes for mounting to a rigid surface. In addition, there are wires protruding from the case for electrical connections. In the area of munitions, small cavities don't always afford the room for a large gage. It was desirable to repack the die in a smaller container and make it a surface mount component for a printed circuit board. A contract was awarded to Endevco to repack the existing die and to develop a triaxial version using that repackaged die. The newly developed accelerometers were tested and evaluated at the U.S. Army Research Laboratory.				
15. SUBJECT TERMS accelerometer, high-g, Endevco, surface mount				
16. SECURITY CLASSIFICATION OF:			17. LIMITATION OF ABSTRACT UL	18. NUMBER OF PAGES 44
a. REPORT UNCLASSIFIED	b. ABSTRACT UNCLASSIFIED	c. THIS PAGE UNCLASSIFIED		
			19b. TELEPHONE NUMBER (Include area code) 410-306-0857	

Contents

List of Figures	iv
Acknowledgments	v
1. Introduction	1
2. Single Axis Accelerometer	1
3. Single Axis Accelerometer Shock Tests	2
4. Triaxial Accelerometer	6
5. Triaxial Accelerometer Shock Tests	7
6. Conclusion	15
Appendix A. Model 70 Gage Specifications	17
Appendix B. Model 73 Gage Specifications	23
Distribution List	29

List of Figures

Figure 1. Endevco model 7270A accelerometer.....	1
Figure 2. Model 70 accelerometer vs. 7270A.....	2
Figure 3. MTS shock table.....	3
Figure 4. Accelerometers on PCB and test fixture.	4
Figure 5. Accelerometers mounted to shock table.....	5
Figure 6. Shock pulse from test 1 of the model 70 accelerometer.....	5
Figure 7. Shock pulse from test 2 of the model 70 accelerometer.....	6
Figure 8. Model 73 triaxial accelerometer.....	7
Figure 9. Triaxial accelerometer and PCB.....	7
Figure 10. Triaxial accelerometer and reference accelerometer.....	8
Figure 11. Test 1 of the triaxial accelerometer (z axis).	8
Figure 12. Test 1 of the triaxial accelerometer (x and y axis).	9
Figure 13. Test 2 of the triaxial accelerometer (z axis).	9
Figure 14. Test 2 of the triaxial accelerometer (x and y axis).	10
Figure 15. Accelerometer secured with Stycast epoxy.....	10
Figure 16. Test 1 of the triaxial accelerometer and Stycast epoxy (z axis).	11
Figure 17. Test 1 of the triaxial accelerometer and Stycast epoxy (x and y axis).	11
Figure 18. Test 2 of the triaxial accelerometer and Stycast epoxy (z axis).	12
Figure 19. Test 2 of the triaxial accelerometer and Stycast epoxy (x and y axis).	12
Figure 20. Test 3 of the triaxial accelerometer and Stycast epoxy (z axis).	12
Figure 21. Test 3 of the triaxial accelerometer and Stycast epoxy (x and y axis).	13
Figure 22. Test 4 of the triaxial accelerometer and Stycast epoxy (z axis).	13
Figure 23. Test 4 of the triaxial accelerometer and Stycast epoxy (x and y axis).	13
Figure 24. Test 5 of the triaxial accelerometer and Stycast epoxy (z axis).	14
Figure 25. Test 5 of the triaxial accelerometer and Stycast epoxy (x and y axis).	14
Figure 26. Test 6 of the triaxial accelerometer and Stycast epoxy (z axis).	14
Figure 27. Test 6 of the triaxial accelerometer and Stycast epoxy (x and y axis).	15

Acknowledgments

The author would like to thank Charlie Goodwin, Dennis Schneider, Bob Carpenter, and Ron Colangelo at PEO-STRI, Orlando, FL, for financial support, program management, and contract management. Bob Sill, Paul Casucci, Kathy Parziale, and Tom Connolly at Endevco were instrumental in developing the accelerometers.

In addition, Barry Bolton and Ken McMullen from the U.S. Army Aberdeen Test Center provided necessary assistance with the design of the accelerometer test boards.

INTENTIONALLY LEFT BLANK.

1. Introduction

The Endevco model 7270A high-g accelerometer has been used successfully in numerous flight tests at the U.S. Army Research Laboratory (ARL). The accelerometer is available in ranges as low as 6,000 g's and as high as 200,000 g's, so they can be used in a variety of situations to measure setback, setforward, and balloting in artillery rounds, mortars, and tank projectiles, to name a few. However, one of the disadvantages of the model 7270A is its physical size. In the area of die level and surface mount components, the 7270A is relatively large. The sensing element is packaged inside a metal case with two clearance holes for no. 2 screws to mount the gage to a rugged surface. From this metal case, wires protrude to make the electrical connections. A photo of the gage can be seen in figure 1.



Figure 1. Endevco model 7270A accelerometer.

With the small cavities available in the area of munitions, a gage of this size will often consume a lot of valuable real estate and in some situations will not fit at all. The intent was to repackage the gage in a surface mount component that could be mounted directly to a printed circuit board (PCB). It was desirable to use the existing die, or one with similar electrical characteristics, and replace the metal housing and mounting scheme with a much smaller package that would consume considerably less space. Endevco was contacted and it was determined that repackaging the die in a smaller surface mount package was an achievable effort. Through the Hardened Subminiature Telemetry and Sensor System program, a contract was awarded to Endevco for this effort, with testing and evaluation at ARL.

2. Single Axis Accelerometer

The die from the existing 7270A accelerometer was repackaged in a small plastic carrier and a surface mount, high-g accelerometer, the model 70, was developed by Endevco. The 7270A is $\sim 0.565 \times 0.275 \times 0.110$ in, whereas the model 70 accelerometer is $\sim 0.250 \times 0.125 \times 0.075$ in. Since the model 70 is a surface mount component, there are no wires extending from it. A photo of the two gages side by side is shown in figure 2. The model 70 gage was made in three

different g's levels: 6,000, 20,000 and 60,000 g's. The specifications of the model 70 gage are listed in appendix A.

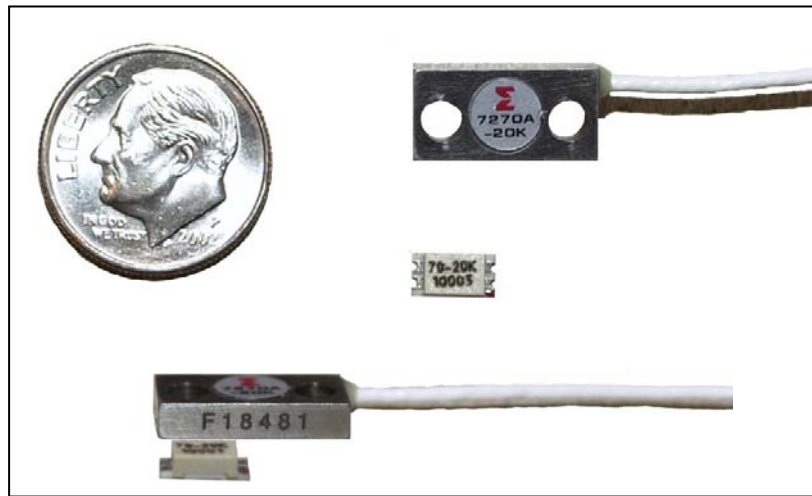

Figure 2. Model 70 accelerometer vs. 7270A.

Endevco, independent of this contract, was redesigning the die used in the 7270A gages. Leveraging that effort, the die used in the model 70, 60,000 g's accelerometer is the new design, whereas, the 6,000-g's and 20,000-g's gages use the existing die. The new die was designed to be transparent to the user in that it had the same or similar electrical and mechanical properties. The main differences are that it is easier and less time consuming to assemble. The existing design requires eight wire bonds, four on the top and four on the bottom, whereas, assembly of the new die requires only four wire bonds and all of them on top.¹

3. Single Axis Accelerometer Shock Tests

Shock table tests were performed on the gages to determine if they performed according to the specifications in the contract. An MTS shock table at ARL was used to perform the tests. The shock table is capable of imparting from a very small shock with a relatively long duration up to a shock as high as 30,000 g's with a short (microsecond) duration. As the shock load increases, the maximum duration obtainable decreases.

To operate the shock table, the device tested is rigidly mounted on a table and, as a unit, the table and device are raised to a given height and held in place via a set of brakes. A bungee cord, attached to the table, applies force in the direction of the base. The higher the table is raised, the more the bungee cord stretches and the load is increased. To impart the shock, the brakes are

¹Sill, B. Endevco, San Juan Capistrano, CA. Private communication, 2002.

released and the table slams down on a solid base. A buffer material, such as felt, is placed on the solid base to program the level of shock. The duration and level of shock is determined by the height of the table and the thickness and makeup of the buffer material. To increase the shock duration, a thicker and/or softer buffer material is used; however, this reduces the maximum shock load for a given height. To obtain a given shock load with a thicker material the table height has to be increased. The trade-off between shock duration and shock pulse is controlled by the table height and buffer material. Figure 3 is a photo of the shock table.

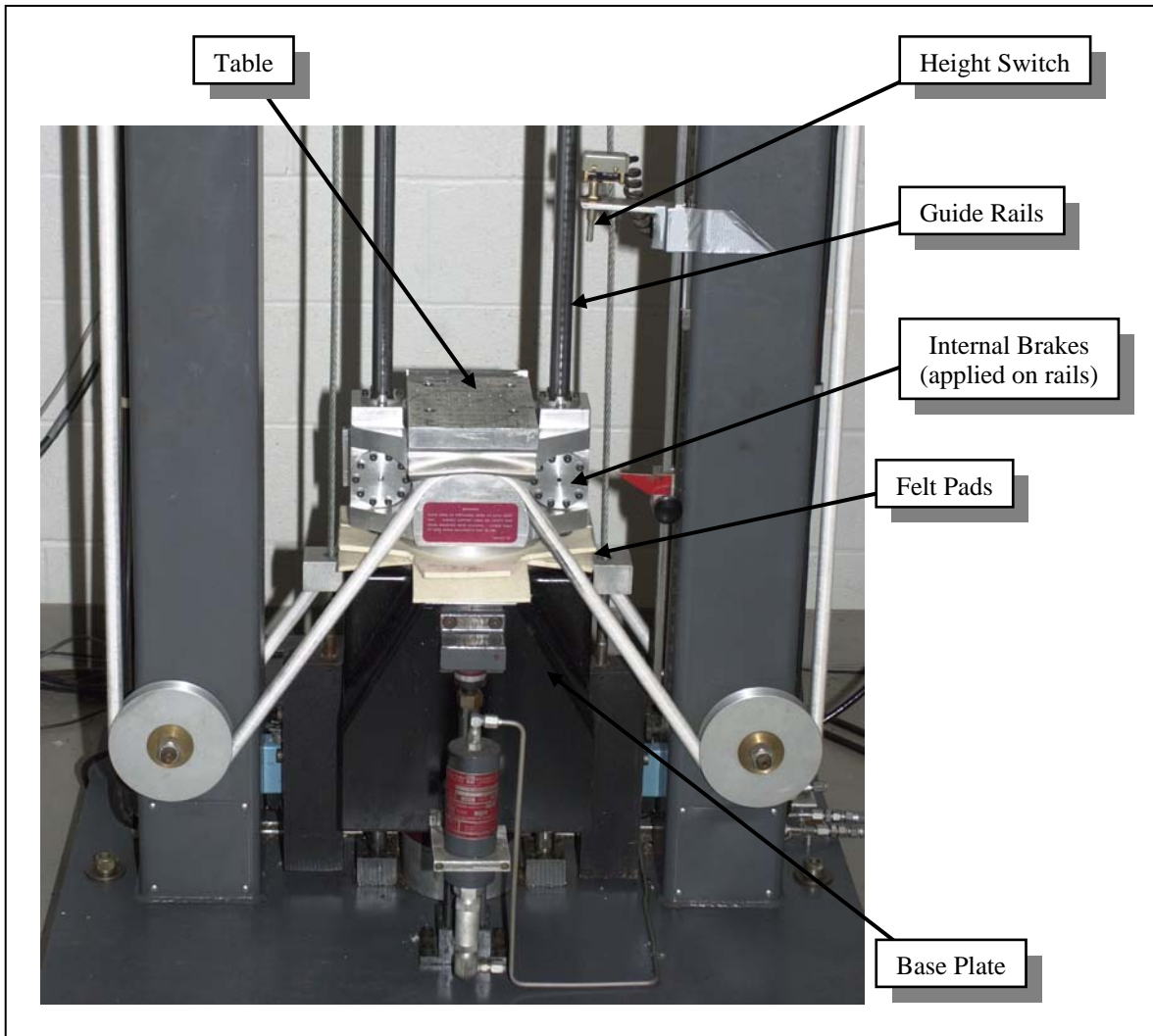

Figure 3. MTS shock table.

Due to several variables on the shock table, it does not always give an identical shock. In order to compare the 7270A gage and the model 70 gage, it was desirable to test them at the same time on the shock table and observe the response of each one. A circuit board was designed and developed that would provide the power regulation for both gages. Figure 4 shows the circuit board with both the 7270A and the model 70 gage mounted on the board. Note that one side of

the 7270A gage was cutoff in order to make it fit on the circuit board. This procedure is used frequently to fit the gage in small locations. Instead of securely mounting it with screws, it was glued to the board with 5-min epoxy and the entire board was bolted to an aluminum plate later mounted to the shock table. With this setup, the two gages are as close together as possible, allowing for a good comparison on the shock table. Figure 5 shows the accelerometers and fixture mounted to the shock table.

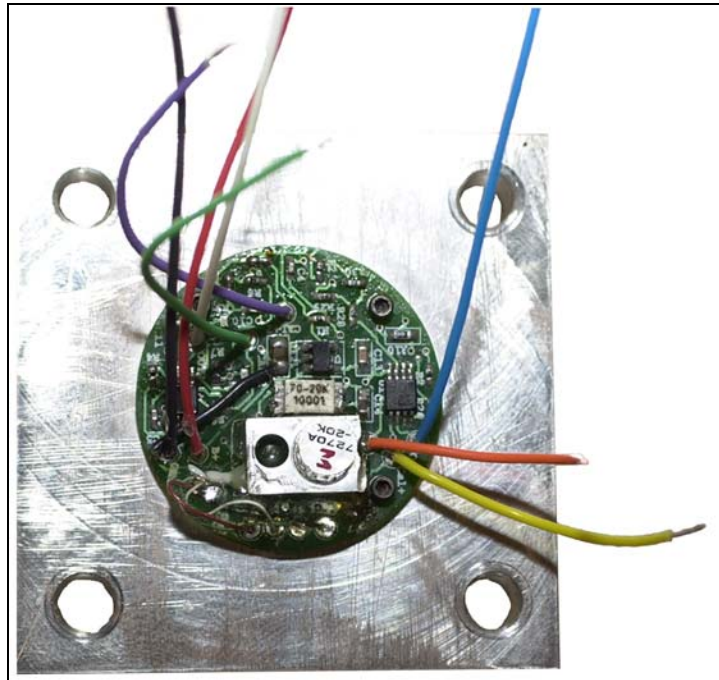

Figure 4. Accelerometers on PCB and test fixture.

Tests were performed with the gages mounted on the shock table, as shown in figures 4 and 5. The sensor output was measured and converted to acceleration according to the gage factors supplied by Endevco with the gages. Figures 6 and 7 are plots of two tests of the model 70 gage vs. the 7270A gage. The graphs show that the response of the model 70 gage is very similar to the response of the 7270A gage. There are minor variations in the shock pulse from one gage to the other; however, this can be expected. Even though the gages were mounted as close together as possible, there are still variations that can occur on the shock table and it is possible that the PCB could have some minor deflections contributing to variations in the shock pulse measured.

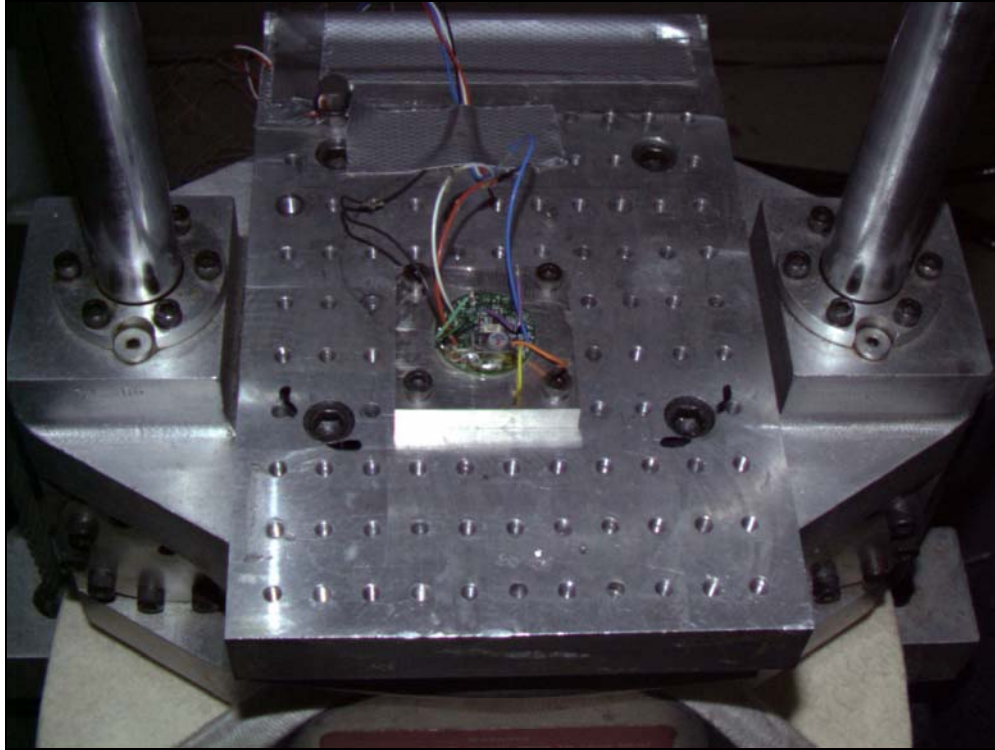

Figure 5. Accelerometers mounted to shock table.

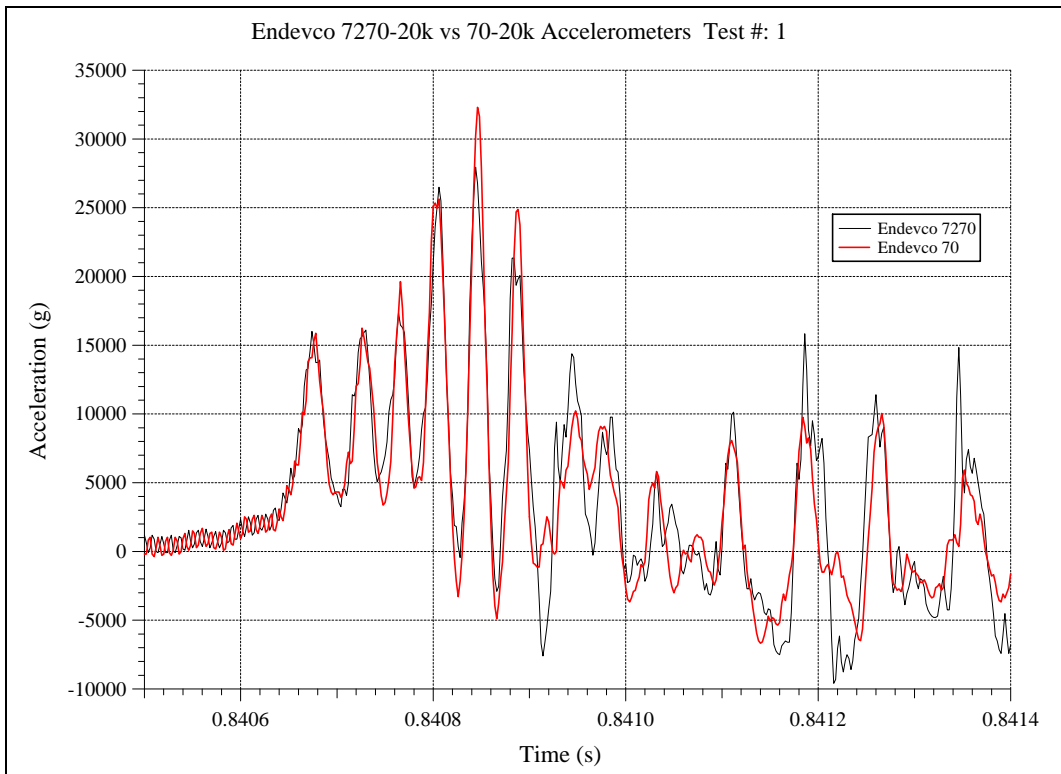

Figure 6. Shock pulse from test 1 of the model 70 accelerometer.

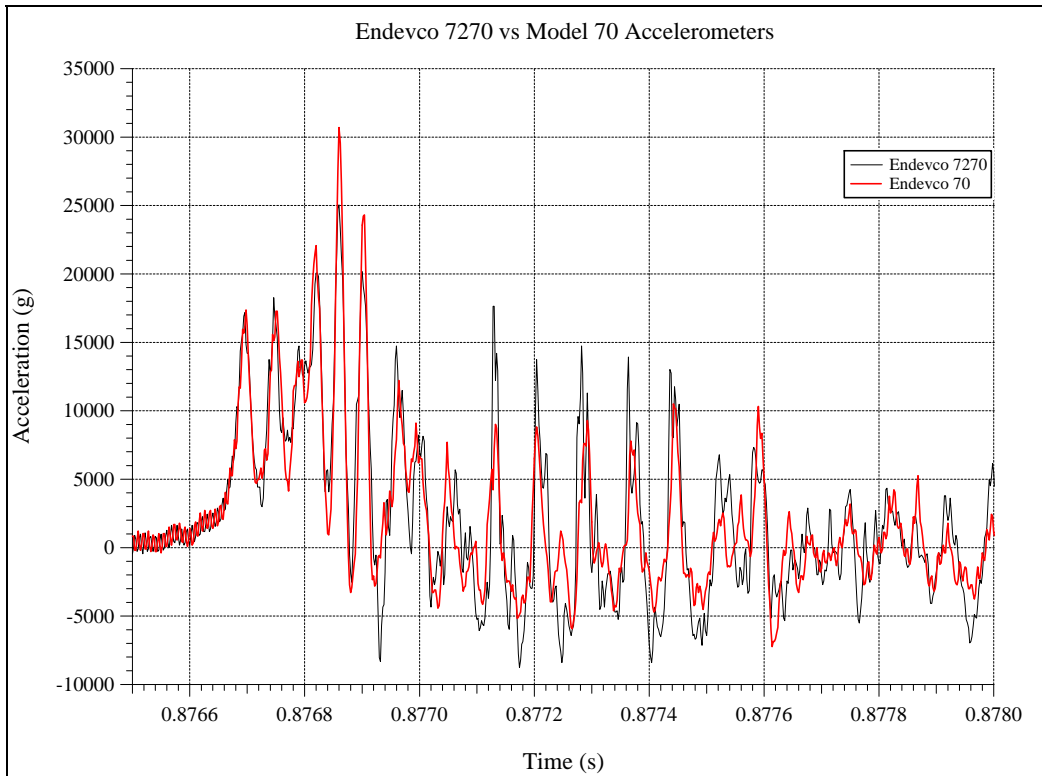

Figure 7. Shock pulse from test 2 of the model 70 accelerometer.

4. Triaxial Accelerometer

In addition to repackaging the die, it was also determined that it would be beneficial to have a surface mount, high-g, triaxial accelerometer. The second phase of the contract was to mount three model 70 gages on a cube that would allow for the measurement of acceleration in all three axes. A cube was developed with electrical traces and three accelerometers were mounted on it. On the bottom of the cube were solder pads so conductive epoxy could be used to mount it to a PCB. In addition to the pads on the bottom of the board, there were also pads on top for wire, in case these were the desired connection points. The accelerometer on the top of the cube was a 60,000-g's accelerometer and the two on the sides were 6,000-g's gages. Any of the three ranges (6, 20, or 60k) can be mounted on the cube; however, the configuration was chosen for a typical gun launch where the top gage would measure setback acceleration and the side gages would measure balloting. Figure 8 is a photo of the model 73 triaxial accelerometer block.² The specifications for the model 73 gage are in appendix B.

²Connolly, T.; Casucci, P. Photo from a presentation entitled Miniature Tri-axial Silicon Accelerometer. *HSTSS Symposium*, Orlando, FL, 14 August 2003.

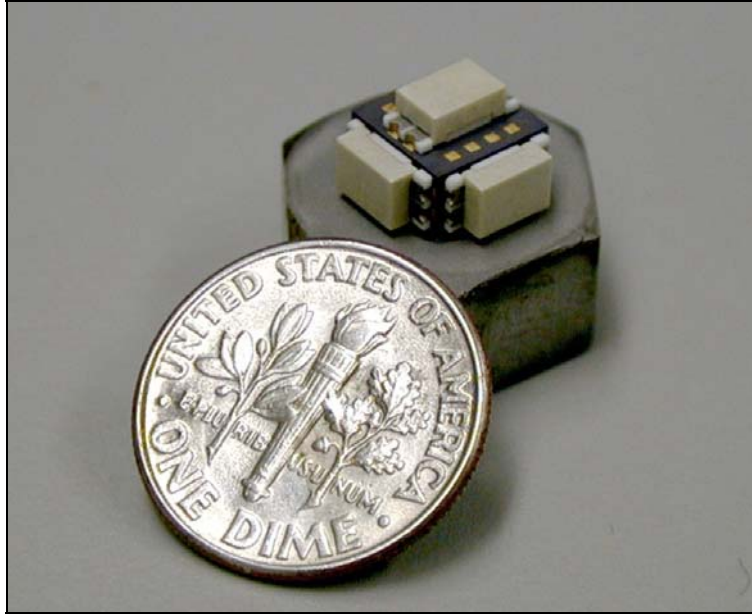

Figure 8. Model 73 triaxial accelerometer.

5. Triaxial Accelerometer Shock Tests

A PCB was developed to test the triaxial accelerometer on the shock table. The PCB provided the power for all three of the accelerometers on the cube. The accelerometer was attached to the PCB via conductive epoxy on the pads on the bottom of the cube. Figure 9 shows the triaxial accelerometer mounted to the PCB.

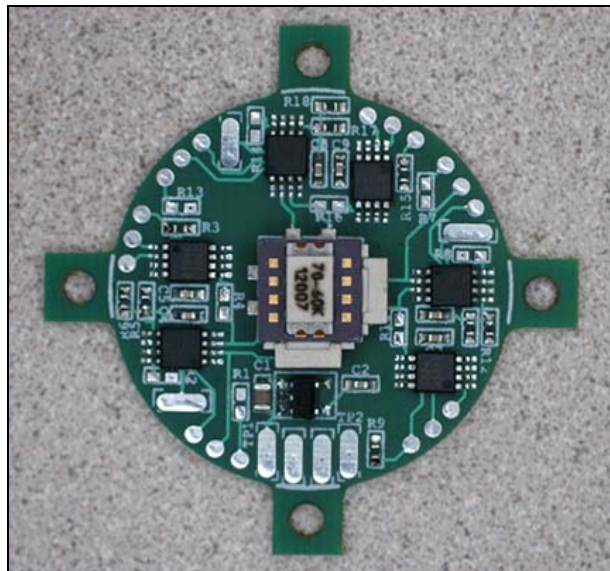

Figure 9. Triaxial accelerometer and PCB.

Similar to phase 1, a 7270 was mounted near the accelerometers as a reference; however, due to space limitations, it was not mounted on the PCB. The 7270A was mounted next to the PCB as shown in figure 10.

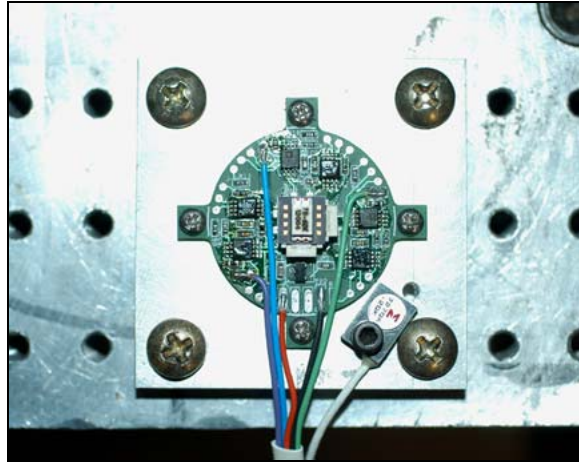

Figure 10. Triaxial accelerometer and reference accelerometer.

The accelerometers were tested in the configuration shown and the results of the first test are shown in figures 11 and 12. The z-axis is the axis in the direction of movement of the shock table, whereas the x and y axes are perpendicular to the axis of movement. The response from the z-axis gage on the model 73 gage is very similar to the 7270A accelerometer. The x and y axis gages measured a small amount of acceleration, which is expected because the shock table is a very harsh environment and it does not produce a unidirectional shock. Although not planned, there is lateral movement which is measured by the x and y accelerometers.

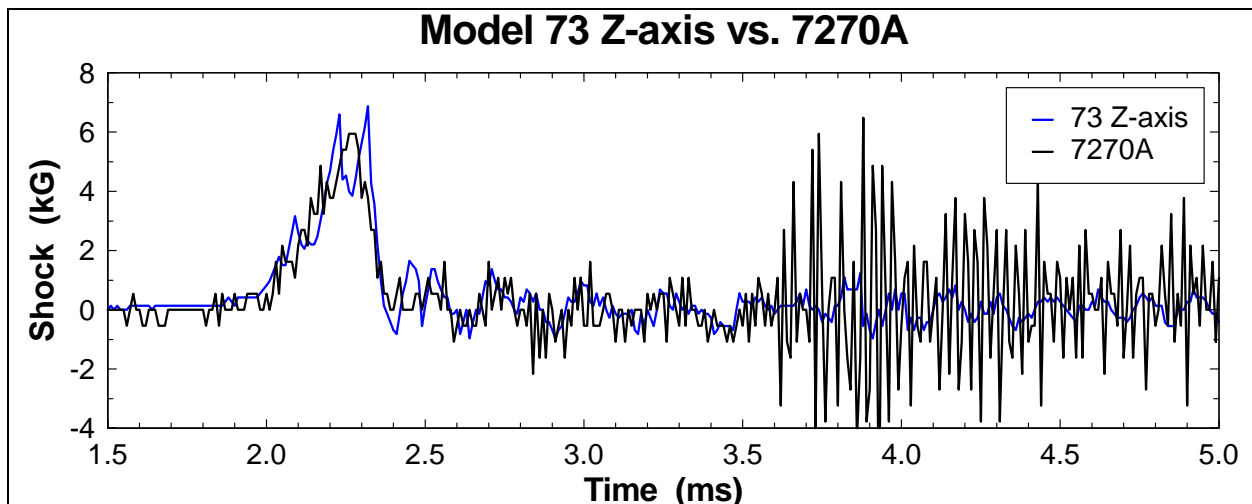

Figure 11. Test 1 of the triaxial accelerometer (z axis).

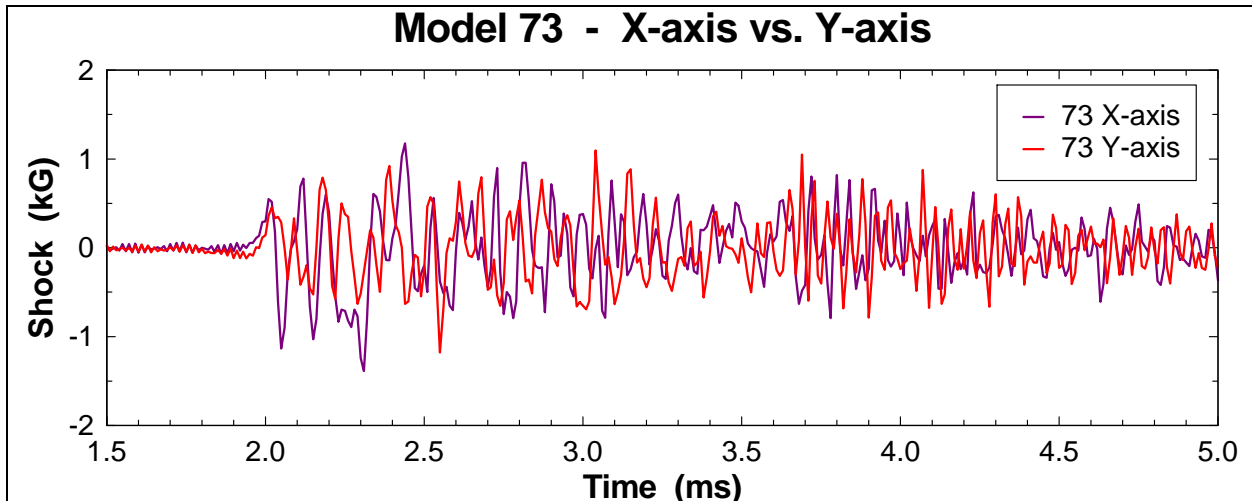

Figure 12. Test 1 of the triaxial accelerometer (x and y axis).

The shock level was increased to determine how well the gage handled a high shock load. Figures 13 and 14 show the results of the test with a shock load of 10,000 g's. In this test, the z axis and y axis gages failed midway. After careful inspection, it was determined that the failure was caused by the gage separating from the board; the conductive epoxy was not strong enough to hold the cube.

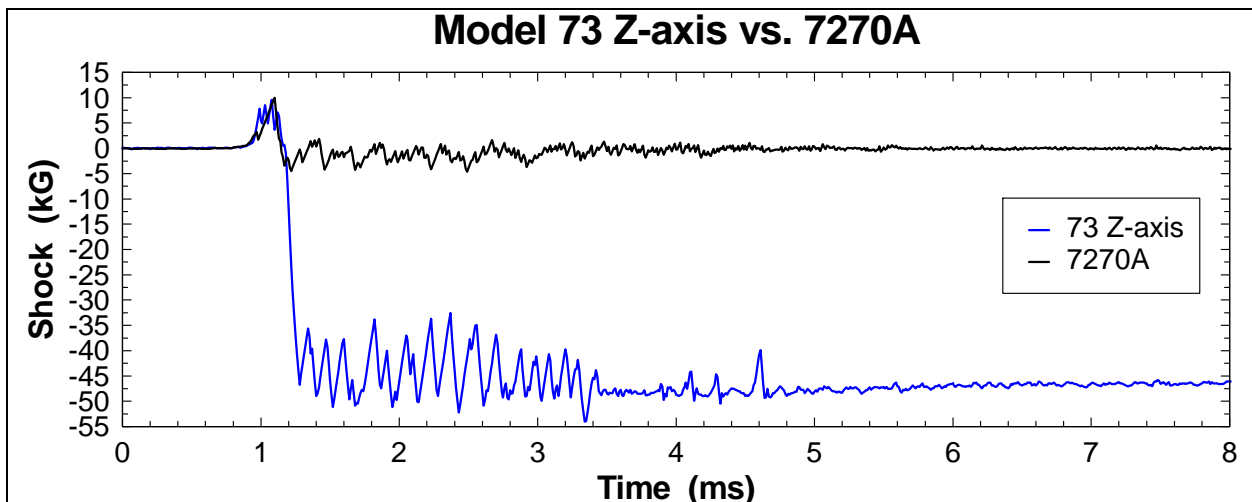

Figure 13. Test 2 of the triaxial accelerometer (z axis).

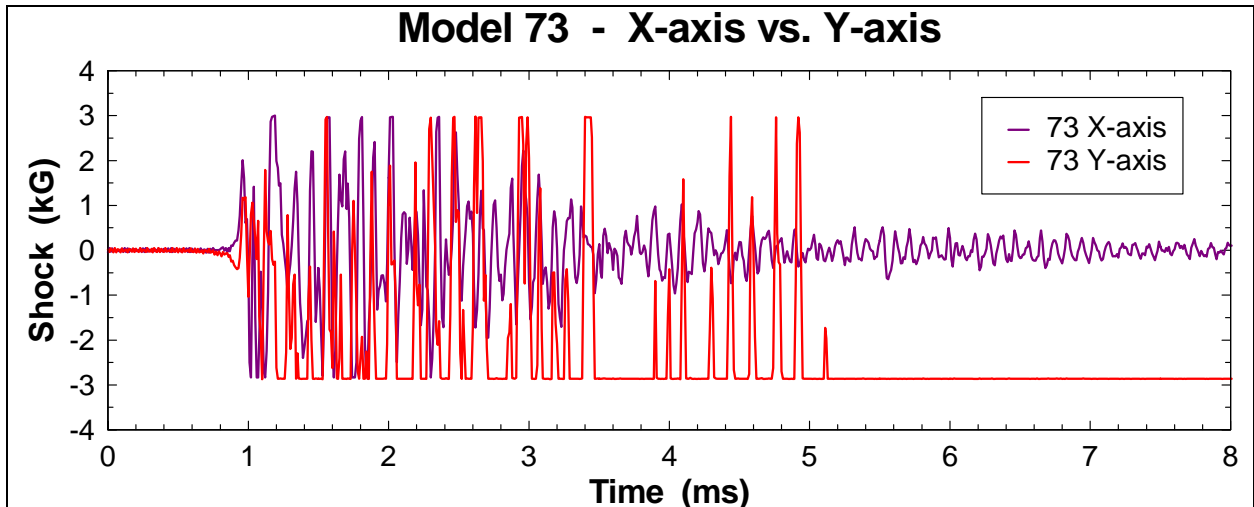

Figure 14. Test 2 of the triaxial accelerometer (x and y axis).

A second set of tests was performed with another accelerometer to determine if it was possible to securely mount the accelerometer to the PCB. For this series of tests, Stycast epoxy was placed around the edges of the cube in addition to the conductive epoxy on the bottom of the cube. Figure 15 shows the mounting scheme for this series.

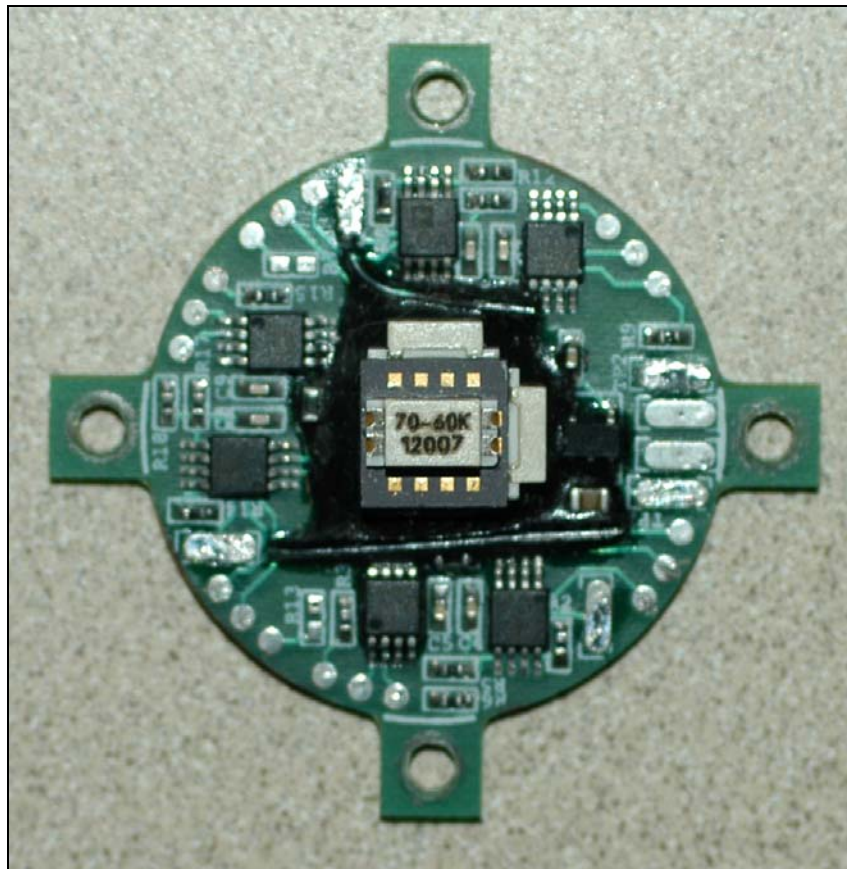

Figure 15. Accelerometer secured with Stycast epoxy.

The test series was repeated with the new mounting scheme and was shocked six times at increasing g' levels. The levels tested were ~5000 g's, 10,000 g's, twice at 20,000 g's, and twice at 30,000 g's. All six tests were successful. The shock pulses can be seen in figures 16–27.

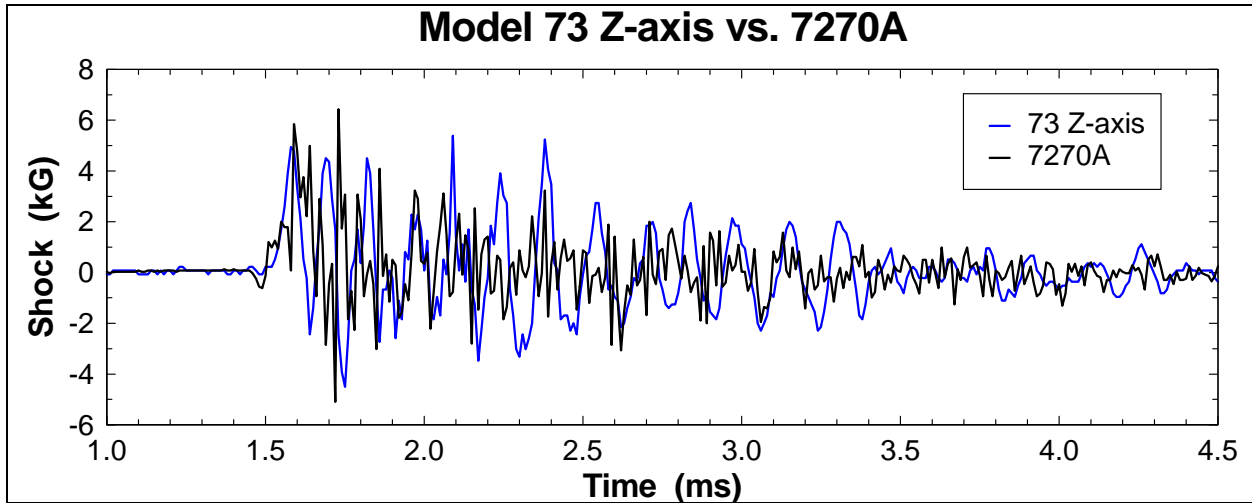

Figure 16. Test 1 of the triaxial accelerometer and Stycast epoxy (z axis).

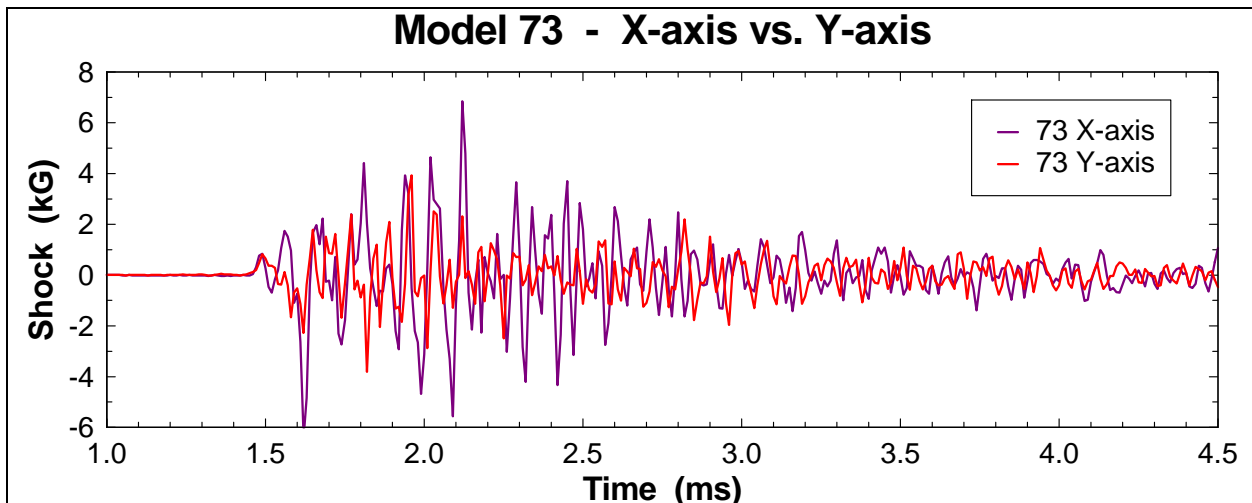

Figure 17. Test 1 of the triaxial accelerometer and Stycast epoxy (x and y axis).

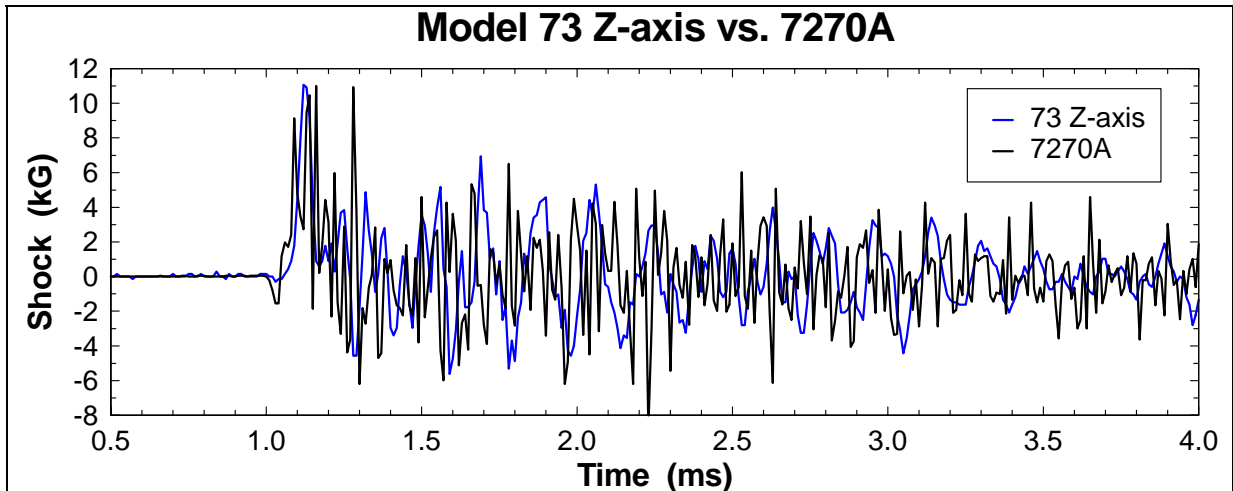

Figure 18. Test 2 of the triaxial accelerometer and Stycast epoxy (z axis).

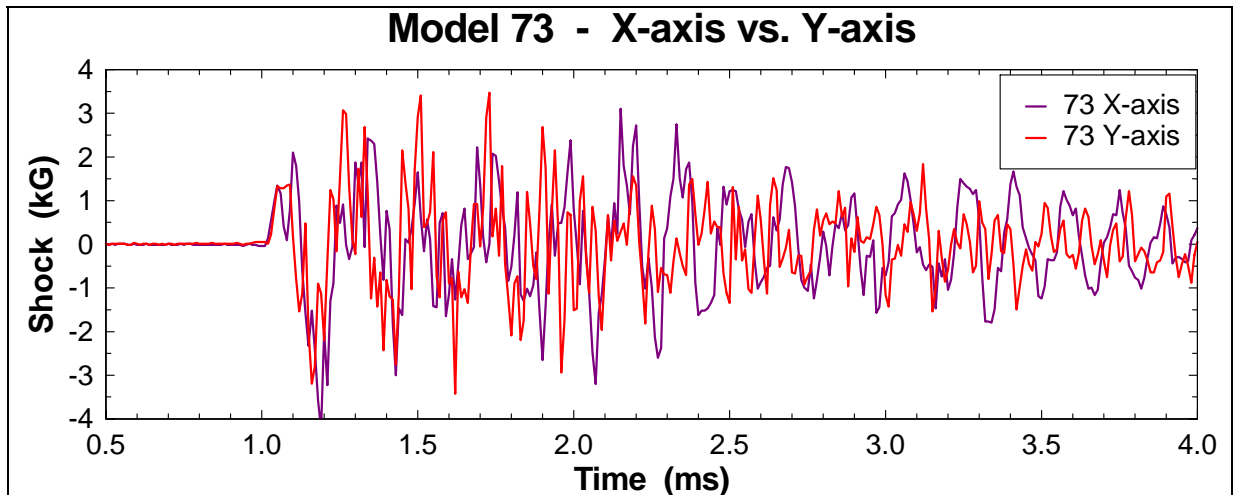

Figure 19. Test 2 of the triaxial accelerometer and Stycast epoxy (x and y axis).

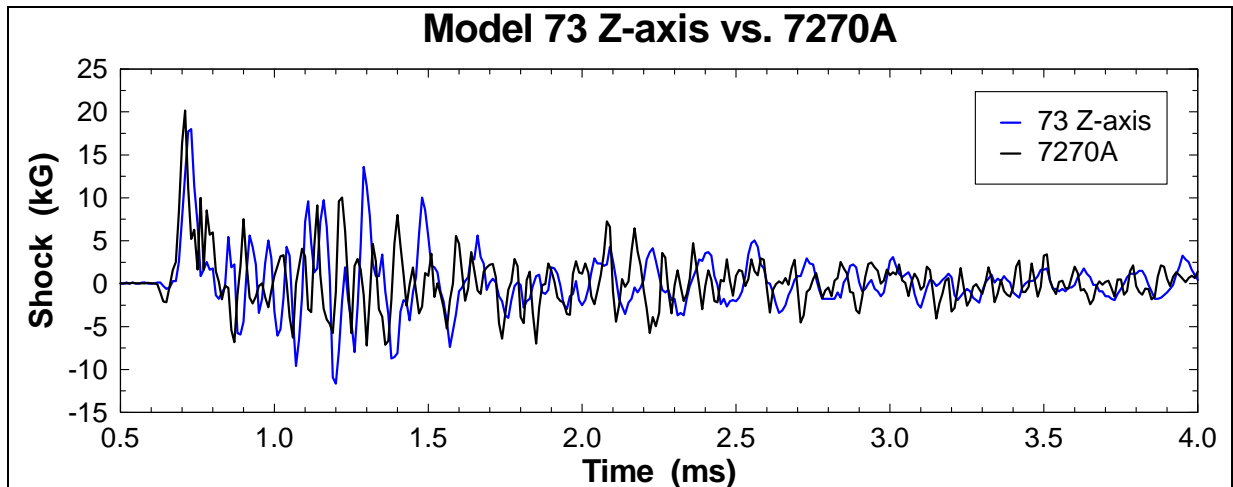

Figure 20. Test 3 of the triaxial accelerometer and Stycast epoxy (z axis).

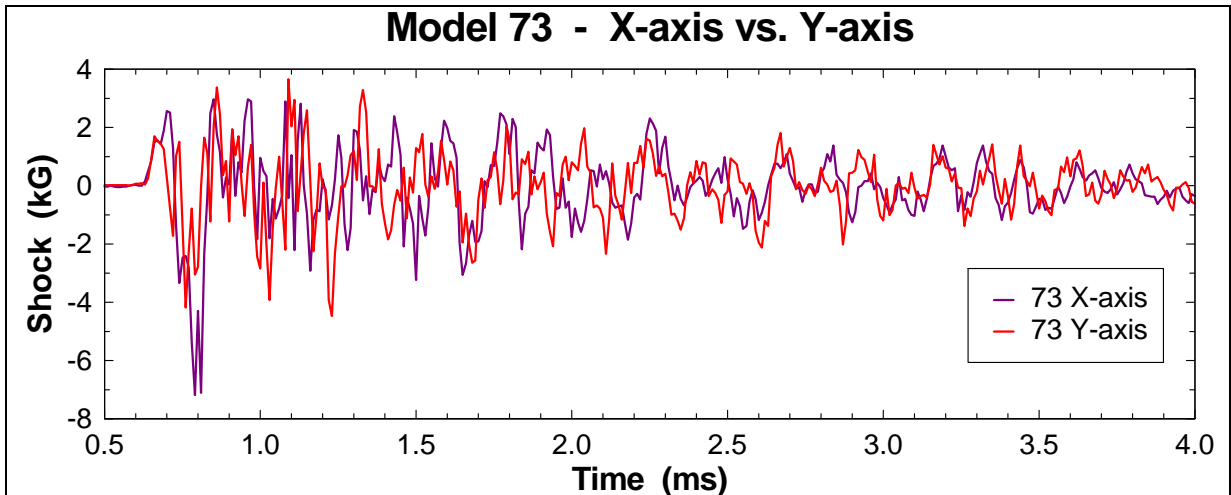

Figure 21. Test 3 of the triaxial accelerometer and Stycast epoxy (x and y axis).

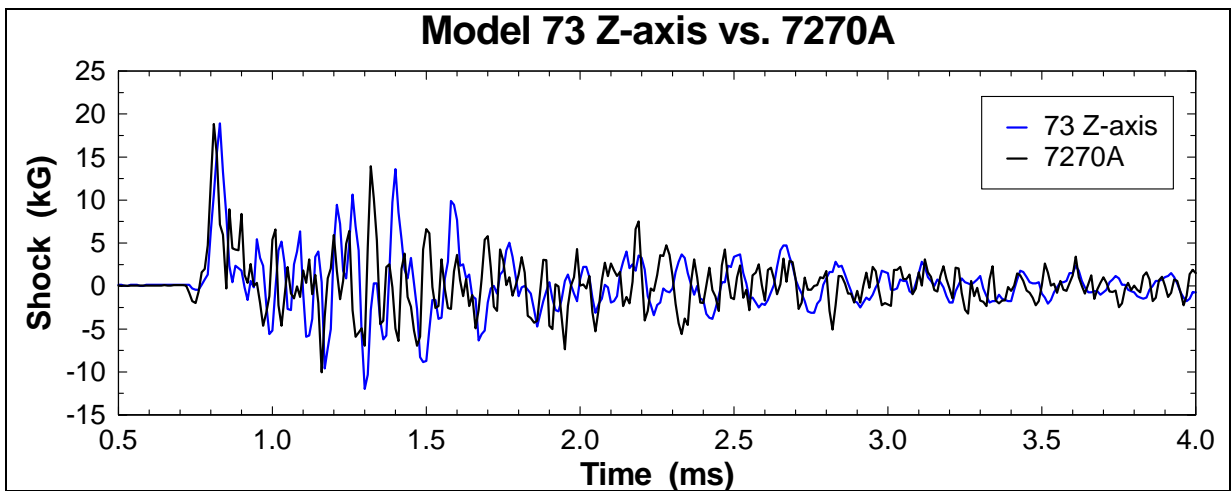

Figure 22. Test 4 of the triaxial accelerometer and Stycast epoxy (z axis).

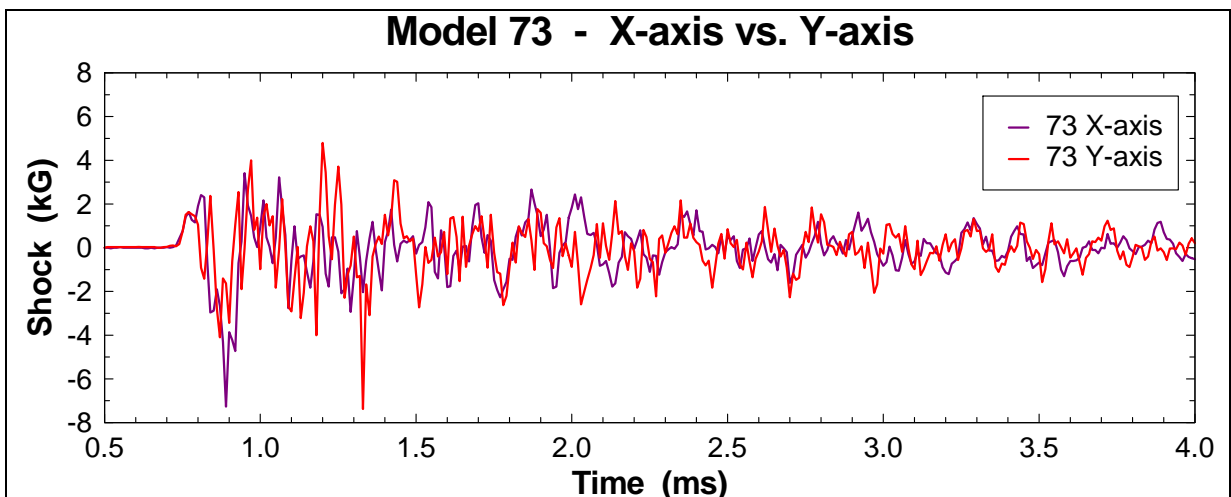

Figure 23. Test 4 of the triaxial accelerometer and Stycast epoxy (x and y axis).

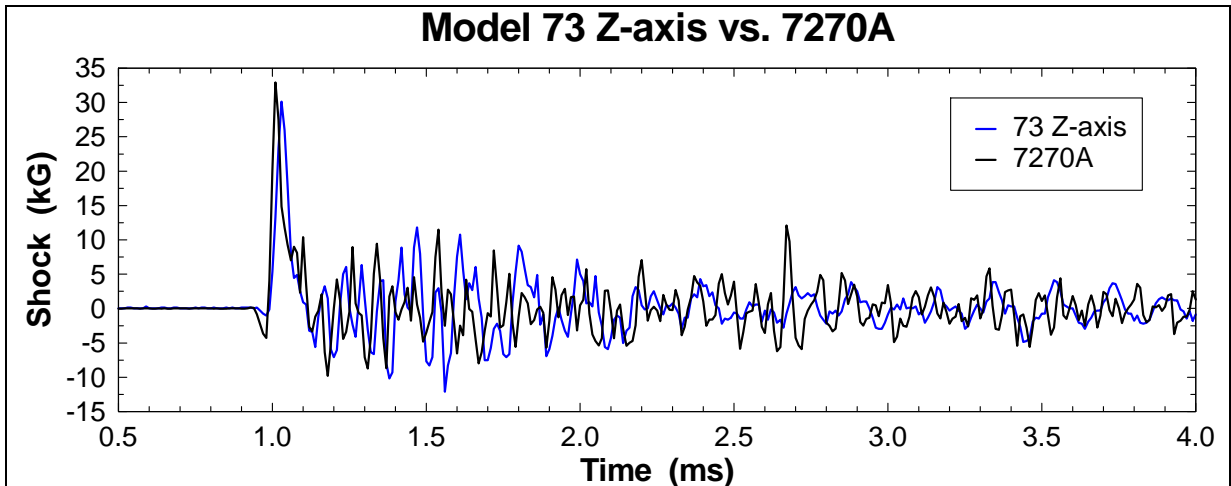

Figure 24. Test 5 of the triaxial accelerometer and Stycast epoxy (z axis).

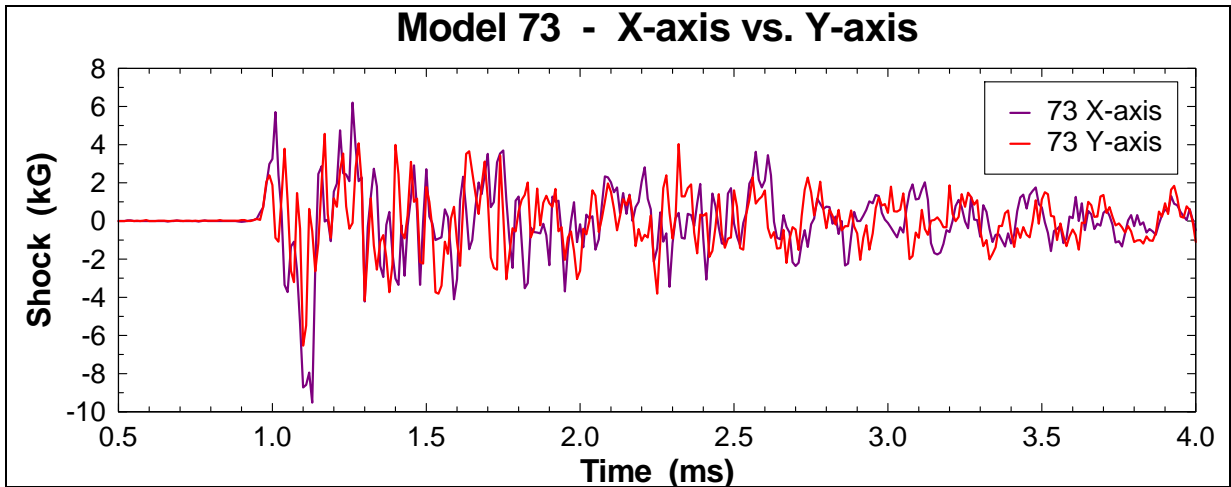

Figure 25. Test 5 of the triaxial accelerometer and Stycast epoxy (x and y axis).

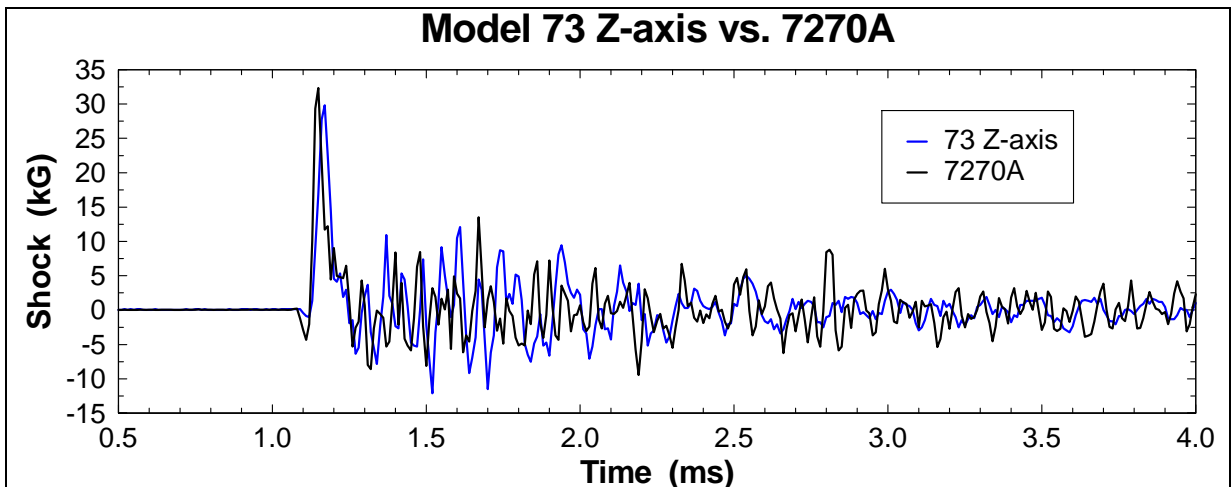

Figure 26. Test 6 of the triaxial accelerometer and Stycast epoxy (z axis).

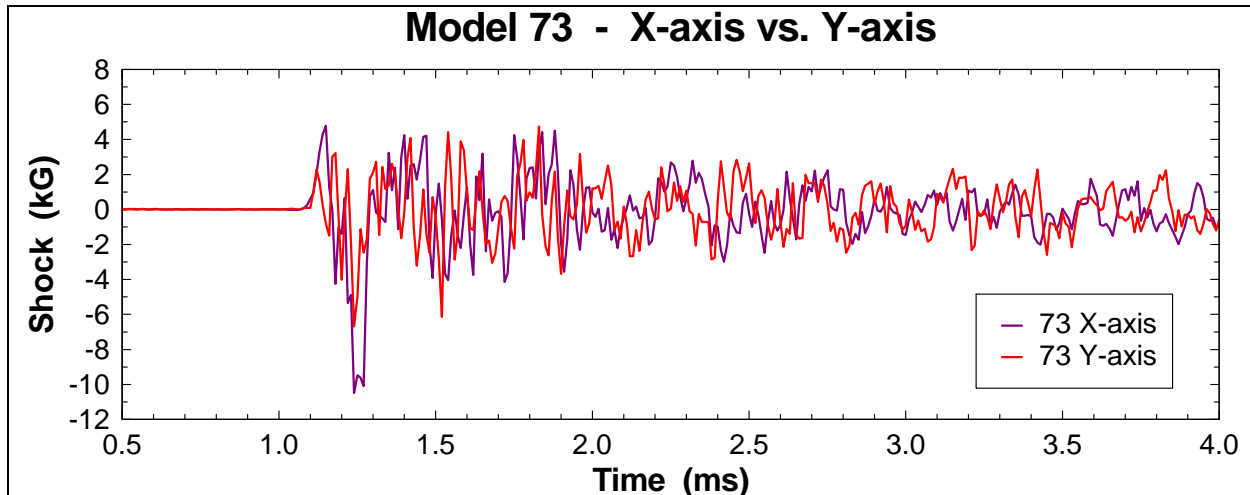

Figure 27. Test 6 of the triaxial accelerometer and Stycast epoxy (x and y axis).

6. Conclusion

Through a contract with Endevco, a new accelerometer, the model 70, was developed, which significantly reduced the size of the 7270A high-g accelerometer. The die of the 7270A was repackaged into a surface mount container that can be attached directly to a PCB; therefore, no protruding wires. The accelerometer was shock tested beyond 25,000 g's and the response was very similar to the standard 7270A gage. This new accelerometer frees up valuable real estate in the small cavities where instrumentation and sensors are often placed.

In addition, the model 70 gage was packaged on a small cube with wire traces to form a triaxial accelerometer, the model 73. The model 73 accelerometer can be connected to a PCB via conductive epoxy on the bottom of the cube or via pads on top of the cube for electrical connections. Shock tests were performed and it was determined that the conductive epoxy was not strong enough to hold the cube in place, so an additional epoxy, Stycast, was required to secure it in place. When properly secured, the accelerometer was shock tested numerous times up to 30,000 g's, and the response of the accelerometer in the z direction was very similar to the reference accelerometer.

INTENTIONALLY LEFT BLANK.

Appendix A. Model 70 Gage Specifications

This appendix appears in its original form, without editorial change.

E

ORIGINATED	RDS	01-16-03	PERFORMANCE SPECIFICATION ACCELEROMETER (FOR MODEL 70-XXX)	PS70	
CHECKED	JRL	01-16-03		PAGE	2 OF 5
APPROVED	RDS	01-17-03		REVISION	B
	LM	01-16-03		EO NUMBER	25728
			DATE	4-21-03	

1.0 **DESCRIPTION**

The ENDEVCO® Model 70 is a family of miniature, rugged, undamped, piezoresistive accelerometers designed for shock measurements. The Leadless Chip Carrier package is designed for surface mount attachment to circuit boards. The highly efficient sensing system of the Model 70 is sculpted from single crystal silicon, which includes the inertial mass and strain gages arranged in a four-active-arm Wheatstone bridge circuit (patent numbers 4,498,229, 4,605,919 and 4,689,600). The extremely small size and unique construction of the element allows exceptionally high resonant frequency. On-chip balance resistors provide low zero measurand output and low thermal zero drift. The light weight flat case is designed for adhesive mounting.

2.0 **PERFORMANCE**

All specifications assume +75°F (+24°C) and 10 volts excitation.

			<u>-6K</u>	<u>-20K</u>	<u>-60K</u>
2.1	RANGE	(g)	6,000	20,000	60,000
2.2	OVERANGE LIMIT [1]	(g)	18,000	60,000	180,000
2.3	AMPLITUDE LINEARITY [1]		±2% of reading up to acceleration corresponding to the recommended range. Measurement uncertainties prevent stating this as a specification limit at accelerations above 10,000 g.		
2.4	ZERO SHIFT DUE TO SHOCK		0.5 mV maximum for half-sine acceleration pulse at 200 mV output, duration greater than 20 microseconds or five periods of the natural frequency.		
2.5	MOUNTED FREQUENCY RESPONSE [2]		20 kHz	50 kHz	100 kHz
	±5% Deviation at				
2.6	SENSITIVITY (Microvolts/g)				
	Min		15	5	1.5
	Typ		30	10	5
	Max		50	15	8.5
2.7	RESONANT FREQUENCY (Kilohertz)				
	Min		120	220	400
	Typ		180	350	700
2.8	TRANSVERSE SENSITIVITY [3]		3% maximum. See Figure 1 for direction of minimum transverse sensitivity		

CONTINUED PRODUCT IMPROVEMENT NECESSITATES THAT ENDEVCO RESERVE THE RIGHT TO MODIFY THESE SPECIFICATIONS WITHOUT NOTICE TO HOLDERS OF PREVIOUS ISSUES.
ED279-1 Rev B 03-29-2000

E

PS70
PAGE 3

2.9	THERMAL SENSITIVITY SHIFT	Typical deviation is -1.2% change in sensitivity per +18°F (+10°C) change in case temperature.
2.10	ZERO MEASURAND OUTPUT	±100 mV maximum at +75°F (+24°C)
2.11	THERMAL ZERO SHIFT	±50 mV maximum, relative to +75°F (+24°C), over operating temperature
3.0	<u>ELECTRICAL</u>	
3.1	EXCITATION	10.00 Vdc, 12 Vdc maximum
3.2	RESISTANCE	650± 300 ohms 650± 300 ohms 1200 ± 400 ohms
3.3	THERMAL COEFFICIENT OF RESISTANCE	1550 ppm/deg C (1.55% change in resistance per 18°F [10°C] change in case temperature.
3.4	WARM-UP TIME	1 second maximum to meet all specifications. Depending on thermal conductivity of mounting surface, the surface temperature may change over a period of minutes causing a drift in ZMO. See note [3].
4.0	<u>PHYSICAL</u>	
4.1	CASE MATERIAL	Alumina substrate with liquid crystal polymer cover.
4.2	WEIGHT	0.06 grams
4.3	IDENTIFICATION	Model number and serial number on top of unit.
4.4	MOUNTING [3]	Structural epoxy under the substrate is recommended to supplement the strength of the electrical connection.
4.5	ELECTRICAL CONNECTIONS	Wrap-around pads and castellations for conductive epoxy or solder [4].
5.0	<u>ENVIRONMENTAL</u>	
5.1	TEMPERATURE	
5.1.1	Operating	-65°F to +250°F (-54°C to +121°C)
5.1.2	Non-operating	TBD [4]
5.2	SHOCK LIMITS [1] [3] (in any direction)	Half-sine pulse of three times the recommended range. Pulse duration should be the greater of 20 microseconds or five periods of the resonant frequency.

E

PS70	
PAGE	4

5.3	HUMIDITY	Epoxy sealed
5.4	BASE STRAIN SENSITIVITY	0.5 mV maximum at 250 microstrain per ISA-RP37.2-1982
6.0	<u>CALIBRATION DATA SUPPLIED</u>	Measured with 10.00 Vdc excitation at room temperature
6.1	SENSITIVITY	Microvolts/g, using shock level of 2000 g minimum
6.2	ZERO MEASURAND OUTPUT	Millivolts
6.3	INPUT AND OUTPUT IMPEDANCE	Ohms

NOTES:

- [1] The unit will operate at accelerations above its recommended range, up to the overrange limit (possibly with slightly degraded linearity). However, above this higher limit, sensor failure may occur. The recommended range is given more to conservatively establish a safety margin than to specify a limit of performance characteristics.
- IMPORTANT: Frequency content of shocks which exceed the overrange limits of the Model 70 often contain significant amplitudes well above 100 kHz. Signal conditioning with insufficient bandwidth may attenuate the signal and indicate significantly lower peak accelerations than actually occur.
- [2] Frequency response should deviate by less than $\pm 5\%$ from dc to indicated frequency, based on the predicted response of a 'single degree of freedom' system. Acceleration levels of conventional techniques are too low for accurate analysis of the frequency response of the higher range models. Measurement uncertainties above 10 kHz prevents stating $\pm 5\%$ as a specification limit.
- These estimates apply to the transducer mounted to an infinitely stiff surface. Frequency response deviations at lower frequencies are likely due to resonances of unsupported thin circuit boards.
- NOTE: The sensor chip includes two masses, each with a separate resonance frequency. Both resonances satisfy the specified minimum resonance frequency. If these resonances are excited, the envelope of the transducer output will exhibit a "beat" frequency, which will not adversely affect results if the signal conditioning is linear at these frequencies.
- [3] For best performance, the accelerometer should be attached parallel to a clean, flat surface. The adhesive should be chosen to match the strength and temperature requirements of the measurement environment. For best frequency response, keep the adhesive under the accelerometer as thin as possible. Tilt of the transducer relative to the mounting surface will affect output due to transverse sensitivity. Thermal conductivity of the adhesive and mounting surface may affect warm up characteristics.
- [4] Solder using temperature controlled tip at 500°F (260°C) for 10 seconds maximum. Recommended solder is Sn63.

E

PS70
PAGE 5

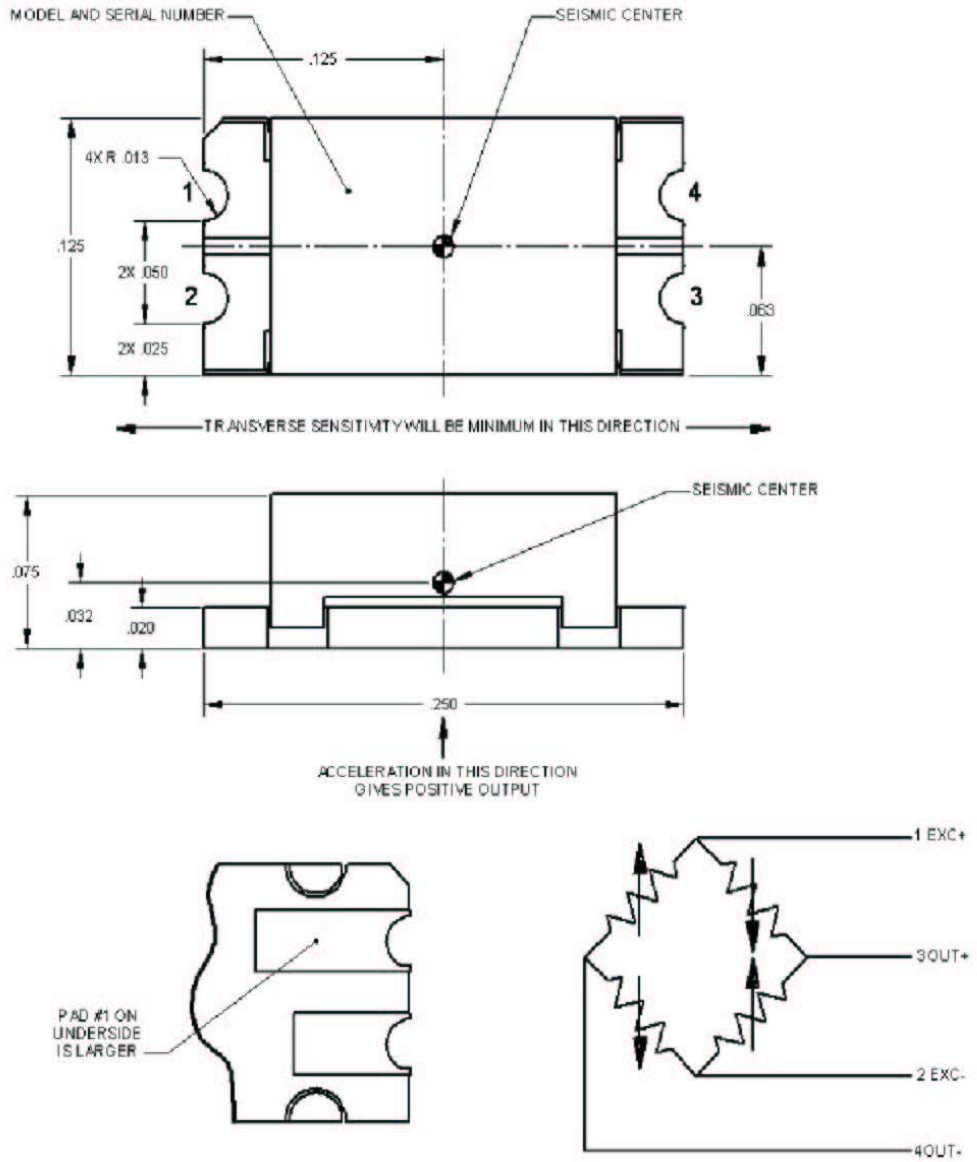

STANDARD TOLERANCE
INCHES (MILLIMETERS)
.XX = ± .02 (.X = ± .5)
.XXX = ± .005 (.XX = ± 0.13)

NO L

FIGURE 1 - OUTLINE DRAWING

E

PS70
PAGE 6

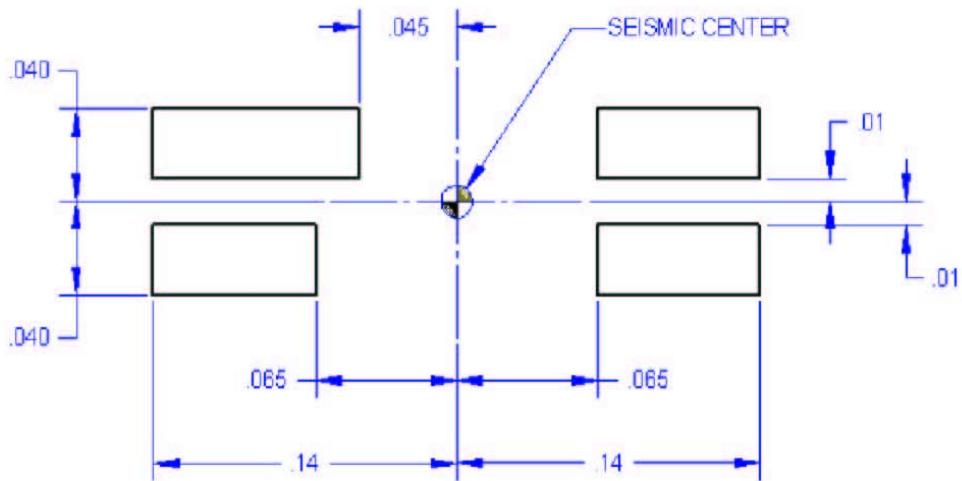

RECOMMENDED FOOTPRINT

STANDARD TOLERANCE
INCHES (MILLIMETERS)
>XX = ± .02 (X = ± .5)
>XXX = ± .005 (XX = ± 0.13)

SOL

FIGURE 2 - OUTLINE DRAWING

Appendix B. Model 73 Gage Specifications

This appendix appears in its original form, without editorial change.

E**OUT ON EO**
26286 (CDS)

ORIGINATED	PC	10-17-03	PERFORMANCE SPECIFICATION TRIAxIAL ACCELEROMETER (FOR MODEL 73-XXX-YYY-ZZZ)	PS73
CHECKED	JRL	10-17-03		PAGE 1 OF 5
APPROVED	KAP	10-17-03		REVISION A
				EO NUMBER 26114
				DATE 10-16-03

1.0 DESCRIPTION

The ENDEVCO® Model 73-XXX-YYY-ZZZ is an assembly of three miniature, rugged, undamped, piezoresistive accelerometers designed for shock measurements in three directions. The Leadless Chip Carrier package is designed for surface mount attachment to circuit boards. The highly efficient sensing system of the Model 73 is sculpted from single crystal silicon, which includes the inertial masses and strain gages arranged in a four-active-arm Wheatstone bridge circuit (patent numbers 4,498,229, 4,605,919 and 4,689,600) for each axis. The extremely small size and unique construction of the elements allows exceptionally high resonant frequencies. On-chip balance resistors provide low zero measurand output and low thermal zero drift. The light flat case is designed for adhesive mounting.

2.0 PERFORMANCE

All specifications assume +75°F (+24°C) and 10 volts excitation.

		<u>-6K</u>	<u>-60K</u>
2.1	RANGE (g)	6,000	60,000
2.2	OVERANGE LIMIT [1] (g)	18,000	180,000
2.3	AMPLITUDE LINEARITY [1]	±2% of reading up to acceleration corresponding to the recommended range. Measurement uncertainties prevent stating this as a specification limit at accelerations above 10,000 g.	
2.4	ZERO SHIFT DUE TO SHOCK	0.5 mV maximum for half-sine acceleration pulse at 200 mV output, duration greater than 20 microseconds or five periods of the natural frequency.	
2.5	MOUNTED FREQUENCY RESPONSE [2] ±5% Deviation at	20 kHz	100 kHz
2.6	SENSITIVITY (Microvolts/g)		
	Min	15	1.5
	Typ	30	5
	Max	50	8.5
2.7	RESONANT FREQUENCY (Kilohertz)		
	Min	120	400
	Typ	180	700
2.8	TRANSVERSE SENSITIVITY [3]	3% maximum. See Figure 1 for direction of minimum transverse sensitivity	

CONTINUED PRODUCT IMPROVEMENT NECESSITATES THAT ENDEVCO RESERVE THE RIGHT TO MODIFY THESE SPECIFICATIONS WITHOUT NOTICE TO HOLDERS OF PREVIOUS ISSUES.
ED279-1 Rev B 03-29-2000

E

PS73
PAGE 2

2.9	THERMAL SENSITIVITY SHIFT	Typical deviation is -1.2% change in sensitivity per +18°F (+10°C) change in case temperature.
2.10	ZERO MEASURAND OUTPUT	±100 mV maximum at +75°F (+24°C)
2.11	THERMAL ZERO SHIFT	±50 mV maximum, relative to +75°F (+24°C), over operating temperature
3.0	<u>ELECTRICAL</u>	
3.1	EXCITATION	10.00 Vdc, 12 Vdc maximum -6K -60K
3.2	RESISTANCE	650 ± 300 ohms 1200 ± 400 ohms
3.3	THERMAL COEFFICIENT OF RESISTANCE	1550 ppm/deg C (1.55% change in resistance per 18°F [10°C] change in case temperature.
3.4	WARM-UP TIME [3]	1 second maximum to meet all specifications. Depending on thermal conductivity of mounting surface, the surface temperature may change over a period of minutes causing a drift in ZMO.
4.0	<u>PHYSICAL</u>	
4.1	CASE MATERIAL	Alumina substrate with liquid crystal polymer covers.
4.2	WEIGHT	0.92 grams
4.3	IDENTIFICATION	Model number and serial number on top of unit.
4.4	MOUNTING [3]	Structural epoxy under the substrate is recommended to supplement the strength of the electrical connection.
4.5	ELECTRICAL CONNECTIONS	Wrap-around pads and castellations for conductive epoxy or solder [4].
5.0	<u>ENVIRONMENTAL</u>	
5.1	TEMPERATURE Operating Non-operating	-65°F to +250°F (-54°C to +121°C) -65°F to +356°F (-54°C to +180°C) [4]
5.2	SHOCK LIMITS [1] [3] (in any direction)	Half-sine pulse of three times the recommended range. Pulse duration should be the greater of 20 microseconds or five periods of the resonant frequency.

E

PS73
PAGE 3

5.3	HUMIDITY	Epoxy sealed
5.4	BASE STRAIN SENSITIVITY	0.5 mV maximum at 250 microstrain per ISA-RP37.2-1982
6.0	<u>CALIBRATION DATA SUPPLIED</u>	Measured with 10.00 Vdc excitation at room temperature
6.1	SENSITIVITY	Microvolts/g, using shock level of 2000 g minimum
6.2	ZERO MEASURAND OUTPUT	Millivolts
6.3	INPUT AND OUTPUT IMPEDANCE	Ohms

NOTES:

- [1] The unit will operate at accelerations above its recommended range, up to the overrange limit (possibly with slightly degraded linearity). However, above this higher limit, sensor failure may occur. The recommended range is given more to conservatively establish a safety margin than to specify a limit of performance characteristics.
- IMPORTANT: Frequency content of shocks that exceed the overrange limits of the Model 73 often contains significant amplitudes well above 100 kHz. Signal conditioning with insufficient bandwidth may attenuate the signal and indicate significantly lower peak accelerations than actually occur.
- [2] Frequency response should deviate by less than $\pm 5\%$ from dc to indicated frequency, based on the predicted response of a 'single degree of freedom' system. Acceleration levels of conventional techniques are too low for accurate analysis of the frequency response of the higher range models. Measurement uncertainties above 10 kHz prevents stating $\pm 5\%$ as a specification limit.
- These estimates apply to the transducer mounted to an infinitely stiff surface. Frequency response deviations at lower frequencies are likely due to resonances of unsupported thin circuit boards.
- NOTE: The sensor chips each include two masses, each with a separate resonance frequency. Both resonances satisfy the specified minimum resonance frequency. If these resonances are excited, the envelope of the transducer output will exhibit a "beat" frequency, which will not adversely affect results if the signal conditioning is linear at these frequencies.
- [3] For best performance, the accelerometer should be attached parallel to a clean, flat surface. The adhesive should be chosen to match the strength and temperature requirements of the measurement environment. For best frequency response, keep the adhesive under the accelerometer as thin as possible. Tilt of the transducer relative to the mounting surface will affect output due to transverse sensitivity. Thermal conductivity of the adhesive and mounting surface may affect warm up characteristics.
- [4] Solder using temperature controlled tip at 500°F (260°C) for 10 seconds maximum. Recommended solder is Sn63.

E

PS73
PAGE 4

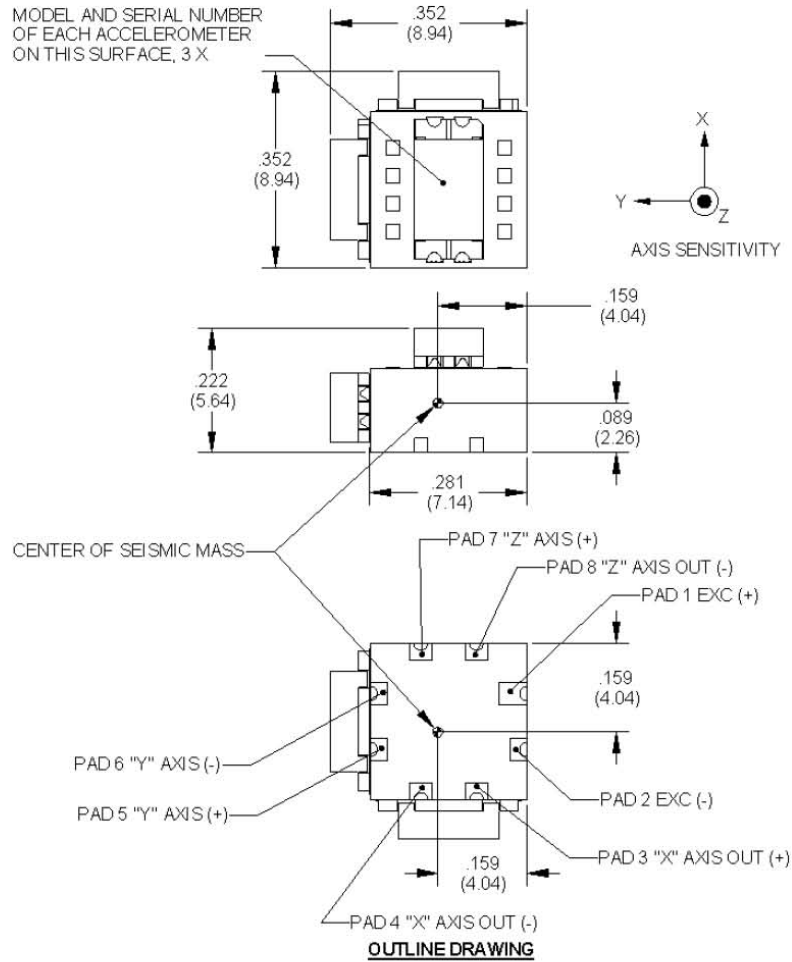

STANDARD TOLERANCE
 INCHES (MILLIMETERS)
 .XX = ± .02 (X = ± .5)
 .XXX = ± .005 (XX = ± .13)

CAD FILE: 80L

FIGURE 1 - OUTLINE DRAWING

E

PS73	
PAGE	5

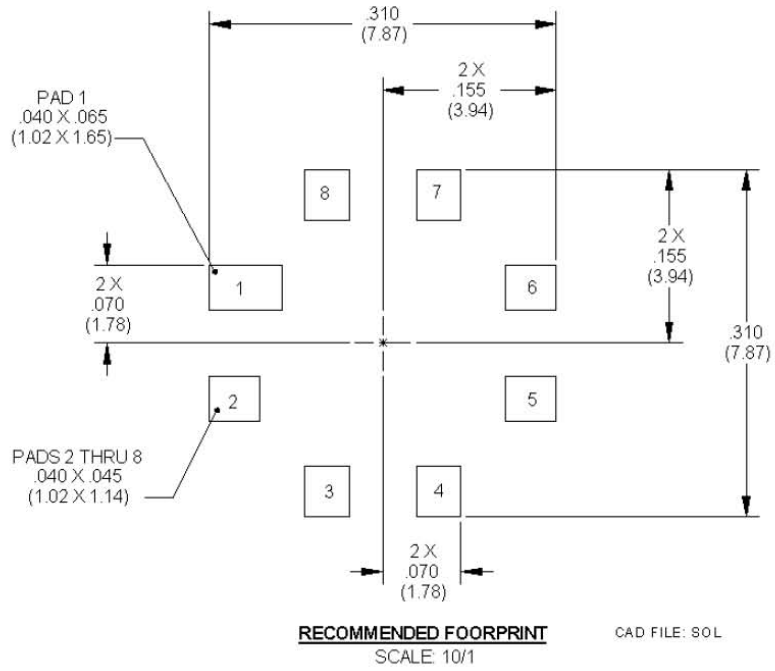

FIGURE 2 - OUTLINE DRAWING

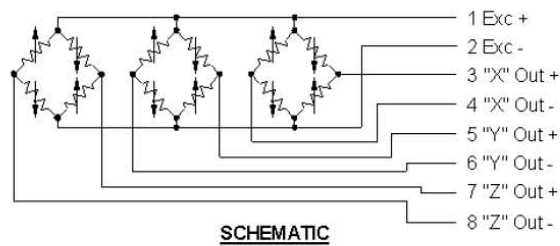

FIGURE 3 - SCHEMATIC

NO. OF COPIES ORGANIZATION

- 1 DEFENSE TECHNICAL
(PDF INFORMATION CTR
ONLY) DTIC OCA
8725 JOHN J KINGMAN RD
STE 0944
FT BELVOIR VA 22060-6218

- 1 COMMANDING GENERAL
US ARMY MATERIEL CMD
AMCRDA TF
5001 EISENHOWER AVE
ALEXANDRIA VA 22333-0001

- 1 INST FOR ADVNCD TCHNLGY
THE UNIV OF TEXAS
AT AUSTIN
3925 W BRAKER LN STE 400
AUSTIN TX 78759-5316

- 1 US MILITARY ACADEMY
MATH SCI CTR EXCELLENCE
MADN MATH
THAYER HALL
WEST POINT NY 10996-1786

- 1 DIRECTOR
US ARMY RESEARCH LAB
IMNE AD IM DR
2800 POWDER MILL RD
ADELPHI MD 20783-1197

- 3 DIRECTOR
US ARMY RESEARCH LAB
AMSRD ARL CI OK TL
2800 POWDER MILL RD
ADELPHI MD 20783-1197

- 3 DIRECTOR
US ARMY RESEARCH LAB
AMSRD ARL CS IS T
2800 POWDER MILL RD
ADELPHI MD 20783-1197

NO. OF COPIES ORGANIZATION

- ABERDEEN PROVING GROUND

- 1 DIR USARL
AMSRD ARL CI OK TP (BLDG 4600)

<u>NO. OF</u> <u>COPIES</u>	<u>ORGANIZATION</u>
3	DIR US ARMY RESEARCH LAB AMSRD ARL SE RL M DUBEY B PIEKARSKI AMSRD ARL SE EE Z SZTANKAY 2800 POWDER MILL RD ADELPHI MD 20783-1197
2	DIR US ARMY RESEARCH LAB AMSRD ARL SE S J EICKE AMSRD ARL SE SA J PRICE 2800 POWDER MILL RD ADELPHI MD 20783-1197
3	DIR US ARMY RESEARCH LAB AMSRD ARL SE SS L ADAS A EDELSTEIN D FLIPPEN 2800 POWDER MILL RD ADELPHI MD 20783-1197
1	DIR US ARMY RESEARCH LAB AMSRD ARL SE R B WALLACE 2800 POWDER MILL RD ADELPHI MD 20783-1197
5	CDR US ARMY TACOM ARDEC AMSRD AAR AEP F(A) W KONICK C ROBINSON M D'ONOFRIO D WARD B CHRISTOPHERSON 2800 POWDER MILL RD ADELPHI MD 20783-1197
1	DIR US ARMY RESEARCH LAB AMSRD ARL WM MB A FRYDMAN 2800 POWDER MILL RD ADELPHI MD 20783-1197
1	DIR US ARMY CECOM RDEC AMSEL RD C2 CS J VIG FORT MONMOUTH NJ 07703-5601
1	CDR US ARMY TACOM ARDEC AMSRD AAR QEM E M BOMUS PICATINNY ARSENAL NJ 07806-5000

<u>NO. OF</u> <u>COPIES</u>	<u>ORGANIZATION</u>
5	CDR US ARMY TACOM ARDEC AMSRD AAR AEM A S CHUNG W KOENIG F BROWN W TOLEDO T RECCHIA PICATINNY ARSENAL NJ 07806-5000
2	CDR US ARMY TACOM ARDEC AMSRD AAR AEM C A MOCK J POTUCEK PICATINNY ARSENAL NJ 07806-5000
2	CDR US ARMY TACOM ARDEC AMSRD AAR AEP S PEARCY M CILLI PICATINNY ARSENAL NJ 07806-5000
7	CDR US ARMY TACOM ARDEC AMSRD AAR AEP E J VEGA P GRANGER D CARLUCCI R WERKO M HOLLIS D TROAST J KALINOWSKI PICATINNY ARSENAL NJ 07806-5000
2	CDR US ARMY TACOM ARDEC AMSRD AAR AEP F H RAND D PASCUA PICATINNY ARSENAL NJ 07806-5000
2	CDR US ARMY TACOM ARDEC AMSRD AAR AEP I S LONGO C HALKIAS PICATINNY ARSENAL NJ 07806-5000
6	CDR US ARMY TACOM ARDEC AMSRD AAR AEP S N GRAY M MARSH B LONDON Q HUYNH C PEREIRA T ZAPATA PICATINNY ARSENAL NJ 07806-5000

<u>NO. OF COPIES</u>	<u>ORGANIZATION</u>
1	CDR US ARMY TACOM ARDEC AMSRD AAR AEM C J MURNANE BLDG 61-S PICATINNY ARSENAL NJ 07806-5000
1	CDR US ARMY TACOM ARDEC AMSRD AAR AEM I R MAZESKI BLDG 65-N PICATINNY ARSENAL NJ 07806-5000
6	CDR US ARMY TACOM ARDEC AMSRD AAR AEM L R CARR M LUCIANO G KOLASA M PALATHINGAL D VO A MOLINA PICATINNY ARSENAL NJ 07806-5000
1	CDR US ARMY TACOM ARDEC SFAE SDR SW IW B D AHMAD BLDG 151 PICATINNY ARSENAL NJ 07806-5000
1	CDR US ARMY TACOM ARDEC SFAE AMO CAS EX C GRASSANO BLDG 171A PICATINNY ARSENAL NJ 07806-5000
1	CDR US ARMY TACOM ARDEC SFAE AMO MAS SMC R KOWALSKI PICATINNY ARSENAL NJ 07806-5000
1	CDR US ARMY TACOM ARDEC SFAE AMO MAS LC D COLLETT BLDG 354 PICATINNY ARSENAL NJ 07806-5000
4	PRODUCT MANAGER FOR MORTARS SFAE AMO CAS MS G BISHER J TERHUNE P BURKE D SUPER BLDG 162 SOUTH PICATINNY ARSENAL NJ 07806-5000

<u>NO. OF COPIES</u>	<u>ORGANIZATION</u>
3	CDR US AMRY TACOM ARDEC SFAE AMO CAS R KIEBLER M MORATZ A HERRERA BLDG 162 SOUTH PICATINNY ARSENAL NJ 07806-5000
1	PROD MGR FOR JOINT LW 155-MM HOW SFAE GCS JLW J SHIELDS BLDG 151 PICATINNY ARSENAL NJ 07806-5000
1	DIR M109A6 PALADIN/M992A2 FAASV PEO GROUND COMBAT SYSTEMS K HURBAN BLDG 171 NORTH PICATINNY ARSENAL NJ 07806-5000
3	US ARMY OPERATIONAL TEST CMD CSTE OTC CC M HAYNES J KOLLER K HENDERSON 91012 STATION AVE FORT HOOD TX 76544-5068
5	CDR NAVAL SURF WARFARE CTR G22 R GAMACHE G32 ELLIS G32 M BOTTASS G33 J FRAYSSE G33 T TSCHIRN 17320 DAHLGREN RD DAHLGREN VA 22448-5100
6	CDR NAVAL SURF WARFARE CTR G34 M TILL G34 H WENDT G34 M HAMILTON S POMEROY G34 S CHAPPELL G34 H MALIN 17320 DAHLGREN RD DAHLGREN VA 22448-5100
3	CDR NAVAL SURF WARFARE CTR G34 J LEONARD G34 W WORRELL G34 M ENGEL 17320 DAHLGREN RD DAHLGREN VA 22448-5100

NO. OF
COPIES ORGANIZATION

4 CDR NAVAL SURF WARFARE CTR
G61 E LARACH
G61 M KELLY
G61 A EVANS
L DESIMONE
17320 DAHLGREN RD
DAHLGREN VA 22448-5100

1 CDR OFC OF NAVAL RSCH
CODE 333
P MORRISSON
800 N QUINCY ST RM 507
ARLINGTON VA 22217-5660

1 DIR NAVAL AIR SYSTEMS CMD
TEST ARTICLE PREP DEP
CODE 5 4
R FAULSTICH
BLDG 1492 UNIT 1
47758 RANCH RD
PATUXENT RIVER MD 20670-1456

1 CDR NAWC WEAPONS DIV
CODE 543200E
G BORGEN
BLDG 311
POINT MUGU CA 93042-5000

1 CDR NAVSEA
CODE 6024
M SIMMS
BLDG 2940W
CRANE IN 47522

1 CDR NAVAL AIR WARFARE CTR
WEAPONS DIVISION
CODE C3904
S MEYERS
CHINA LAKE CA 93555-6100

4 PROGRAM MANAGER ITTS
PEO-STRI
AMSTI EL
D SCHNEIDER
C GOODWIN
R CARPENTER
R COLANGELO
12350 RESEARCH PKWY
ORLANDO FL 32826-3276

1 CDR US ARMY
CSTE DTC YP YT ED
M LAUSS
YPG AZ 85365-9498

NO. OF
COPIES ORGANIZATION

2 CDR US ARMY
CSTE DTC YP MT EW
D HO
I GOODE
YPG AZ 85365-9498

1 CDR US ARMY
CSTE DTC YP YT GC EV
B AYNES
YPG AZ 85365-9498

1 CDR US ARMY
STEYP TD ATO
A HART
YPG AZ 85365-9106

2 CDR US ARMY RDEC
AMSRD AMR SG SD
P JENKINS
AMSRD AMR SG SP
P RUFFIN
BLDG 5400
REDSTONE ARSENAL AL 35898-5247

3 CDR US ARMY RDEC
AMSRD AMR SG NC
V LEFEVRE
S BURGETT
C ROBERTS
BLDG 5400
REDSTONE ARSENAL AL 35898-5247

2 CDR US ARMY RDEC
AMSRD AMR WS
P ASHLEY
AMSRD AMR WS DP
B ROBERTSON
BLDG 7804
REDSTONE ARSENAL AL 35898-5247

1 CDR US ARMY RDEC
AMSRD AMR AS AC
G HUTCHESON
BLDG 5400
REDSTONE ARSENAL AL 35898-5247

2 DIR US ARMY RTTC
STERT TE F TD
R EPPS
CSTE DTC RT F TD (B 7855)
S HAATAJA
REDSTONE ARSENAL AL 35898-8052

<u>NO. OF</u> <u>COPIES</u>	<u>ORGANIZATION</u>
1	CDR US ARMY RDEC AMSRD AMR WS ID T HUDSON BLDG 5400 REDSTONE ARSENAL AL 35898-5247
1	CDR US ARMY WEST DESERT TEST CENTER CSTE DTC DP WD MU T M BULLETT DUGWAY PROVING GROUND UT 84022-5000
1	CDR AFRL/MNMF S ROBERSON 306 W EGLIN BLVD STE 219 EGLIN AFB FL 32542-6810
1	DARPA/MTO C NGUYEN 3701 N FAIRFAX DR ARLINGTON VA 22203-1714
1	OSD DOT&E R&R W ATTERBURY 1700 DEFENSE PENTAGON WASHINGTON DC 20301-1700
2	OSD DOT&E CTEIP PROGRAM OFFICE J TEDESCHI D HINTON 4850 MARK CENTER DR ALEXANDRIA VA 22311
2	IDA SCIENCE AND TECH DIV H LAST K WALZL 4850 MARK CENTER DR ALEXANDRIA VA 22311-1882
1	ARROW TECH ASSOCIATES W HATHAWAY 1233 SHELBURNE RD STE 8 SOUTH BURLINGTON VT 05403
1	CAMBER CORP W CHIUSANO 200 VALLEY RD SUITE 403 MOUNT ARLINGTON NJ 07856

<u>NO. OF</u> <u>COPIES</u>	<u>ORGANIZATION</u>
5	ALLIANT TECHSYSTEMS A GAUZENS J MILLS B LINDBLOOM E KOSCO D JACKSON PO BOX 4648 CLEARWATER FL 33758-4648
2	ALLIANT TECHSYSTEMS C CANDLAND R DOHRN 5050 LINCOLN DR MINNEAPOLIS MN 55436-1097
2	ALLIANT TECHSYSTEMS G PICKUS F HARRISON 4700 NATHAN LANE NORTH PLYMOUTH MN 55442
7	ALLIANT TECHSYSTEMS ALLEGANY BALLISTICS LAB S OWENS C FRITZ J CONDON B NYGA J PARRILL M WHITE S MCCLINTOCK MS WV01-08 BLDG 300 RM 180 210 STATE RT 956 ROCKET CENTER WV 26726-3548
2	SAIC J DISHON G PHILLIPS 16701 W BERNARDO DR SAN DIEGO CA 92127
3	SAIC J GLISH J NORTHRUP G WILLENBRING 8500 NORMANDEALE LAKE BLVD STE 1610 BLOOMINGTON MN 55437-3828
1	SAIC M PALMER 1410 SPRING HILL RD STE 400 MCLEAN VA 22102
1	SAIC D HALL 1150 FIRST AVE STE 400 KING OF PRUSSIA PA 19406

<u>NO. OF COPIES</u>	<u>ORGANIZATION</u>
2	ROCKWELL COLLINS M JOHNSON R MINOR 350 COLLINS RD NE CEDAR RAPIDS IA 52498
3	JOHNS HOPKINS UNIV APPLIED PHYSICS LAB W D'AMICO K FOWLER K REBELLO 1110 JOHNS HOPKINS RD LAUREL MD 20723-6099
5	CHLS STARK DRAPER LAB J CONNELLY J SITOMER R POLUTCHKO T EASTERLY A KOUREPENIS 555 TECHNOLOGY SQUARE CAMBRIDGE MA 02139-3563
2	ECIII LLC R GIVEN J SWAIN BLDG 2023E YPG AZ 85365
2	LOCKHEED MARTIN MP 562 S BISHOP MP 951 A WINDON 5600 SAND LAKE RD ORLANDO FL 32819
1	LOCKHEED/MARTIN-SANDERS M CARLSON NCA1 2078 95 CANAL ST NASHUA NH 03061-0868
1	KAMAN AEROSPACE CORP RAYMOND ENGINEERING OPERATIONS D SPENCER 217 SMITH ST MIDDLETOWN CT 06457-9990
5	RAYTHEON MISSILE SYSTEMS MS12-4 B PETERSON P VO R KREBS T WERCH B RETTIG PO BOX 11337 TUSCON AZ 85734-1337

<u>NO. OF COPIES</u>	<u>ORGANIZATION</u>
2	RAYTHEON MISSILE SYSTEMS MS11 10 R GOURLEY D STREETER PO BOX 11337 TUSCON AZ 85734-1337
2	CUSTOM ANALYTICAL ENG SYSTEMS A ALEXANDER S ADAMS 13000 TENSOR LANE NE FLINTSTONE MD 21530
9	UNITED DEFENSE LP C BIES T BLUMER B CITRO B ENGEL M HAFTON T MELODY S MILLER D MIERHOFFER J RUPERT MS380 4800 EAST RIVER RD MINNEAPOLIS MN 55421-1498
1	ALION SCIENCE P KISATSKY 12 PEACE RD RANDOLPH NJ 07861
	<u>ABERDEEN PROVING GROUND</u>
39	DIR USARL AMSRD ARL WM T ROSENBERGER AMSRD ARL WM B T KOGLER AMSRD ARL WM SG B RINGERS AMSRD ARL WM BA J CONDON B DAVIS T HARKINS D HEPNER G KATULKA M WILSON P MULLER P PEREGINO (5 CPS) A THOMPSON T BROWN R HALL B PATTON M CHILDERS AMSRD ARL WM BC P PLOSTINS

NO. OF
COPIES ORGANIZATION

NO. OF
COPIES ORGANIZATION

	B GUIDOS P WEINACHT M BUNDY J NEWILL J GARNER AMSRD ARL WM BD M NUSCA J COLBURN T COFFEE AMSRD ARL WM BF S WILKERSON H EDGE AMSRD ARL WM MB J BENDER W DRYSDALE AMSRD ARL WM T B BURNS AMSRD ARL WM TC R COATES R MUDD B SORENSEN R SUMMERS R PHILLABAUM		
4	CDR US ARMY TACOM ARDEC AMSRD AAR AEF T R LIESKE J MATTS F MIRABELLE J WHITESIDE BLDG 120	1	CDR USAATC CSTE DTC AT TD S WALTON BLDG 359
1	CDR USAATC CSTE DTC AT TC M ZWIEBEL BLDG 400	1	CDR USAEC CSTE AEC SVE B D SCOTT BLDG 4120
2	CDR USAATC CSTE DTC AT FC S T GARCIA CSTE DTC AT CO J WALLACE BLDG 400		
3	CDR USAATC CSTE DTC AT TD B K MCMULLEN CSTE DTC AT SL B D DAWSON B BOLTON BLDG 359		
2	CDR USAATC CSTE DTC AT FC L R SCHNELL J DAMIANO BLDG 400		

INTENTIONALLY LEFT BLANK.