



Characterization of Candidate Materials for Composite Cartridge Case

**by Aristedes Yiournas, Brian M. Powers,
Travis A. Bogetti, and William H. Drysdale**

ARL-TR-3341

September 2004

NOTICES

Disclaimers

The findings in this report are not to be construed as an official Department of the Army position unless so designated by other authorized documents.

Citation of manufacturer's or trade names does not constitute an official endorsement or approval of the use thereof.

Destroy this report when it is no longer needed. Do not return it to the originator.

Army Research Laboratory

Aberdeen Proving Ground, MD 21005-5069

ARL-TR-3341

September 2004

Characterization of Candidate Materials for Composite Cartridge Case

**Aristedes Yiournas, Brian M. Powers,
Travis A. Bogetti, and William H. Drysdale
Weapons and Materials Research Directorate, ARL**

REPORT DOCUMENTATION PAGE			Form Approved OMB No. 0704-0188		
Public reporting burden for this collection of information is estimated to average 1 hour per response, including the time for reviewing instructions, searching existing data sources, gathering and maintaining the data needed, and completing and reviewing the collection information. Send comments regarding this burden estimate or any other aspect of this collection of information, including suggestions for reducing the burden, to Department of Defense, Washington Headquarters Services, Directorate for Information Operations and Reports (0704-0188), 1215 Jefferson Davis Highway, Suite 1204, Arlington, VA 22202-4302. Respondents should be aware that notwithstanding any other provision of law, no person shall be subject to any penalty for failing to comply with a collection of information if it does not display a currently valid OMB control number. PLEASE DO NOT RETURN YOUR FORM TO THE ABOVE ADDRESS.					
1. REPORT DATE (DD-MM-YYYY) September 2004		2. REPORT TYPE Final		3. DATES COVERED (From - To) October 2002	
4. TITLE AND SUBTITLE Characterization of Candidate Materials for Composite Cartridge Case			5a. CONTRACT NUMBER		
			5b. GRANT NUMBER		
			5c. PROGRAM ELEMENT NUMBER		
6. AUTHOR(S) Aristedes Yiournas, Brian M. Powers, Travis A. Bogetti, and William H. Drysdale			5d. PROJECT NUMBER 622618.AH80		
			5e. TASK NUMBER		
			5f. WORK UNIT NUMBER		
7. PERFORMING ORGANIZATION NAME(S) AND ADDRESS(ES) U.S. Army Research Laboratory ATTN: AMSRD-ARL-WM-MB Aberdeen Proving Ground, MD 21005-5069			8. PERFORMING ORGANIZATION REPORT NUMBER ARL-TR-3341		
9. SPONSORING/MONITORING AGENCY NAME(S) AND ADDRESS(ES)			10. SPONSOR/MONITOR'S ACRONYM(S)		
			11. SPONSOR/MONITOR'S REPORT NUMBER(S)		
12. DISTRIBUTION/AVAILABILITY STATEMENT Approved for public release; distribution is unlimited.					
13. SUPPLEMENTARY NOTES					
14. ABSTRACT Cased telescoped ammunition designs were developed for the Multi-Role Armament and Ammunition System that employed a composite cartridge case. Three candidate composite material systems are being considered for the application—50% chopped fiberglass/Nylon 12, 30% chopped fiberglass/ULTEM (a registered trademark of GE Plastics Corp.), and a continuous fiberglass/urethane. Each of these material systems was subjected to preliminary mechanical testing in order to characterize their basic material properties and to support finite-element modeling of the cartridge case/gun chamber during the firing cycle. Basic mechanical properties such as stress-strain curves, Poisson's ratio, and residual plastic deformation after unloading were obtained and are presented in this report.					
15. SUBJECT TERMS composite materials, cartridge case, characterization					
16. SECURITY CLASSIFICATION OF:			17. LIMITATION OF ABSTRACT	18. NUMBER OF PAGES	19a. NAME OF RESPONSIBLE PERSON
a. REPORT	b. ABSTRACT	c. THIS PAGE			19b. TELEPHONE NUMBER (Include area code)
UNCLASSIFIED	UNCLASSIFIED	UNCLASSIFIED	UL	40	Aristedes Yiournas 302-831-6324

Contents

List of Figures	iv
List of Tables	iv
Acknowledgments	v
1. Introduction	1
2. Sample Materials and Test Preparation	2
3. Test Results	3
3.1 The 50% Fiberglass/Nylon.....	3
3.2 The 30% Fiberglass/ULTEM.....	7
3.2.1 Extruded Fiberglass/ULTEM.....	8
3.2.2 Injection-Molded Fiberglass/ULTEM.....	8
3.3 Fiberglass/Urethane.....	10
3.3.1 [0°] ₅ Fiberglass/Urethane	10
3.3.2 [90°] ₁₀ Fiberglass/Urethane	10
3.3.3 [±45°] ₅ Fiberglass/Urethane	12
3.3.4 [0°/90°] ₅ Fiberglass/Urethane	14
4. Conclusions	16
Distribution List	17

List of Figures

Figure 1. Illustration of tensile specimen sectioning from sample tubes and radial coordinate system with respect to tube arc.	2
Figure 2. Illustration of tensile specimen sectioning from sample tubes and radial coordinate system with respect to tube arc.	5
Figure 3. Examples of Poisson’s ratio behavior of Nylon 12 material.	6
Figure 4. Example of load/unload of Nylon 12 material for residual strain characteristics.	6
Figure 5. Micrograph of Nylon 12 material where alignment can be seen near tube inner wall in longitudinal direction. View is looking into the “theta” direction.	7
Figure 6. Representative example of extruded/machined ULTEM series results.	8
Figure 7. Summary of injection molded ULTEM series results.	9
Figure 8. Summary of Poisson’s ratio behavior of both ULTEM series.	9
Figure 9. Summary of $[0^\circ]_5$ urethane response obtained prior to end tab debond.	10
Figure 10. Poisson’s ratio behavior of $[0^\circ]_5$ urethane series specimens.	11
Figure 11. Initial portion of $[90^\circ]^{10}$ urethane response. Strains exceeded gage capabilities, while loads remained low until failure.	11
Figure 12. Example of Poisson’s ratio behavior of a $[90^\circ]_{10}$ urethane specimen. Strain gage measured lateral contraction on outer ply face, which was resisted by the alignment of the fibers in this direction. Through-thickness behavior is not represented and may differ significantly.	12
Figure 13. Tensile response of a $[\pm 45^\circ]_{10}$ coupon.	13
Figure 14. Reduction of $[\pm 45^\circ]_{10}$ tensile data into shear coordinate system.	13
Figure 15. Apparent Poisson’s ratio behavior on outer ply face of a $[\pm 45^\circ]_{10}$ specimen.	14
Figure 16. Stress-strain data reduced from $[0^\circ/90^\circ]_{10}$ tests. Odd failure region results from strain gage being mounted on outer 0° ply, which failed prior to catastrophic specimen failure. This ply partially relaxed before specimens went on to a slightly higher load.	15
Figure 17. Observed Poisson’s ratio behavior on outer 0° ply of $[0^\circ/90^\circ]_{10}$ samples.	15

List of Tables

Table 1. Summary of tensile test configurations.	4
Table 2. Summary of tensile test results.	4
Table 3. Summary of residual strain after loading/elastic recovery.	5

Acknowledgments

This research was supported in part by an appointment to the Research Participation Program at the U.S. Army Research Laboratory (ARL) administered by the Oak Ridge Institute for Science and Education through an interagency agreement between the U.S. Department of Energy and ARL.

INTENTIONALLY LEFT BLANK.

1. Introduction

A cartridge case contains the propellant and ignition system necessary to launch a projectile from a gun and provides alignment to allow the projectile to enter the gun tube smoothly. After the firing cycle is complete, the case must be extracted from the gun chamber to allow the next round to be loaded.

Conventional breech loaded cartridge cases have traditionally been made of brass or steel. The case is inserted into the chamber of a gun, and the propellant is ignited. Relatively low pressure is needed to expand the case until it contacts the gun chamber wall, taking up the clearance designed between the case and chamber wall. From this point in the loading until peak pressure, the gun chamber provides the major part of the resistance to gun pressure.

The deformation of the gun chamber by the propellant pressure is completely elastic due to the residual stresses created in the gun tube by the autofrettage process. In contrast, the deformation in the case commonly contains a significant plastic component.

As the propellant pressure decreases in the chamber, both the case and chamber shrink elastically. The goal of the case design and material selection is to ensure that the plastic deformation is not allowed to develop to such a level that there is no clearance between the case and the chamber wall after all pressure has been exhausted.¹

Further aid in the extraction of a conventional case is obtained by including a slight taper in the case and chamber wall. Then, any rearward movement of the case due to engagement of the extractor pins at breech opening further increases the clearance and assists smooth extraction.

Cased telescoped ammunition (CTA) was developed for use in the Multi-Role Armament and Ammunition System (MRAAS) swing chamber gun. This concept places additional design burdens on the cartridge case.

For the swing chamber gun, the round is loaded into the chamber in its rotated position. The chamber is then turned 90° so that it is aligned with the gun tube, and the round is fired. The chamber is then rotated back into the open position, and the spent cartridge is extracted by being pushed through the chamber by the loading of the next round.²

The cartridge must now seal both ends of the chamber, not just the breach end, as with conventional guns. This push-through feature for removing spent rounds means that the chamber

¹U.S. Army Materiel Command. *Engineering Design Handbook: Ammunition Series, Section 4, Design Projection*; AMCP 706-247, July 1964.

²FC Munition Design Team Review. Picatinny Arsenal, NJ, 11 July 2000.

and case cannot be tapered to aid in extraction. Thus, the responsibility for ease of case extraction falls solely on case design (clearances, etc.) and material selection.

The material must deform without failing under firing pressures and elastically recover enough deformation so that the spent case can be removed by the force of loading. Since the gun chamber absorbs the majority of the propellant pressure, ductility and elastic recovery, rather than strength, are the important properties of the sought material.

2. Sample Materials and Test Preparation

Three composite material systems were evaluated for use in the CTA. They are fiberglass/Nylon 12, fiberglass/ULTEM,^{*} and fiberglass/urethane. The Nylon 12 and ULTEM matrix composites used chopped fiberglass, while the urethane composites used continuous fiberglass laminates.

The fiberglass/Nylon 12 was supplied as a hollow tube of ~6° inches in length and 5.5 inches in diameter, made by injection molding. The wall thickness was 0.375 in. The fiber reinforcement consisted of chopped fiberglass of 50% weight. Narrow arcs were cut out and machined into rectangular blocks from which tensile test coupons were sectioned with a precision slot-grinder machine fitted with a diamond cut-off saw. This process and the tube coordinate system are illustrated in figure 1.

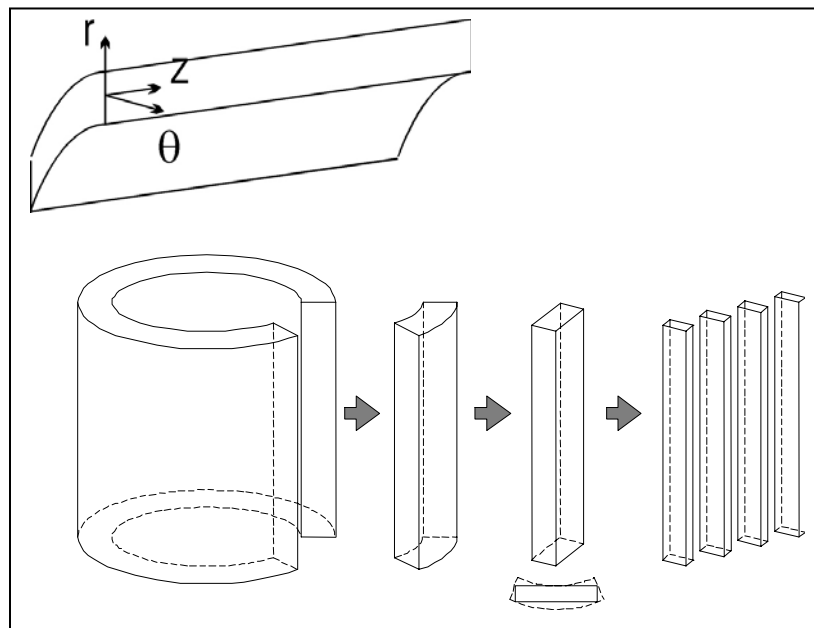

Figure 1. Illustration of tensile specimen sectioning from sample tubes and radial coordinate system with respect to tube arc.

^{*}ULTEM is a registered trademark of GE Plastics Corp.

The 30% weight fiberglass/ULTEM was also supplied in two hollow tubes, with the effects of two manufacturing processes investigated. Both tubes had a diameter of 5.5 in and a length of 6 in. The first tube was made by machining an extruded fiberglass/ULTEM cylinder. After extrusion, the cylinder was machined to a 0.25-in wall thickness, and end-seal chevrons were placed on each end of the tube. The second tube was manufactured by injection molding and had a wall thickness of 0.375 in. This tube was supplied with no further processing after being injection molded. Samples from both the ULTEM matrix tubes were prepared by the same process outlined for the Nylon 12 matrix tube.

The fiberglass/urethane samples were manufactured by the hand lay-up of unidirectional fiberglass plies into flat panels with various laminates from which tensile coupons were sectioned directly. The manufacturing process took place at the U.S. Army Research Laboratory facility located in Aberdeen, MD. The four lay-ups manufactured were $[0^\circ]_5$, $[90^\circ]_{10}$, $[\pm 45^\circ]_5$, and $[0^\circ/90^\circ]_5$. Test samples were cut from the flat panels using a slot-grinder fitted with a diamond cut-off wheel.

As was practical, all materials were tensile tested in the best accordance with ASTM D 3039.³ This standard specifies whether bonded end tabs or friction tabs, such as emory cloth, are appropriate for random, discontinuous fiber composites. Where applicable, end-tab material was a fiberglass composite. Except for where specifically noted, Hysol^{*} structural adhesive was used to bond the end tabs to the samples. An Instron[†] 4484 multipurpose test machine was used to perform tensile tests on all the samples, and cross-head displacement rates varied from 0.05 to 0.5 in/min, depending on lay-up as defined in the ASTM D 3039 standard. Table 1 summarizes the test configurations and loading rates for all test samples. Except where noted, all specimens were instrumented with strain gages to measure both longitudinal and transverse strain. Young's modulus and Poisson's ratio were determined from this data.

3. Test Results

Data from the Instron's load cell and a strain gage acquisition computer was reduced to stress vs. strain curves. It was found that all materials except for $[0^\circ]_5$ and $[0^\circ/90^\circ]_{10}$ fiberglass/urethane exhibited a nonlinear softening curve. Tables 2 and 3 summarize all of the test results. Sections 3.1–3.3 discuss individual materials.

3.1 The 50% Fiberglass/Nylon

The first series of tests on the 50% fiberglass/Nylon 12 was not fitted with strain gages. Because calculation of strain from crosshead displacement was inaccurate, stress-strain curves could not be constructed for series 1. Tensile strength was determined and found to be ~7–8 ksi.

³ASTM D 3039. Standard Test Method for Tensile Properties of Fiber-Resin Composites, *Annu. Book ASTM Stand.* **2002**.

^{*}Hysol is a registered trademark of the Dexter Corp.

[†]Instron is a registered trademark of the Instron Corp.

Table 1. Summary of tensile test configurations.

Material	Original Section	Dimensions (in)	End Tabs/ Adhesive/No.	Loading Rate (in/min)
Nylon series 1	3/8-in wall tube injection mold	4 × 0.31 × 0.13	2 tabbed (quick epoxy) 2 untabbed	0.05
Nylon series 2	3/8-in wall tube injection mold	4 × 0.29 × 0.09	3 tabbed (quick epoxy) 2 untabbed	0.025
Nylon series 3	3/8-in wall tube injection mold	4 × 0.33 × 0.09	6 tabbed (Hysol 9309)	0.025
ULTEM extruded	1/4-in wall tube machined	4.38 × 0.39 × 0.1	4 untabbed emory cloth	0.025
ULTEM injection molded	3/8-in wall tube injection mold	6 × 0.31 × 0.1	4 untabbed emory cloth	0.025
Urethane [0°] ₁₀	~1/10-in sheet 5 plies	10 × 0.5 × 0.09	4 tabbed (Hysol 1C)	0.05
Urethane [90°] ₁₀	~1/4-in sheet 10 plies	10 × 1 × 0.24	5 tabbed (Hysol 9309) 3 untabbed	0.5
Urethane [±45°] ₅	~1/4-in sheet 10 plies	10 × 1 × 0.22	5 tabbed (Hysol 9309)	0.25
Urethane [0°/90°] ₅	~1/4-in sheet 10 plies	10 × 1 × 0.24	5 untabbed	0.05

Table 2. Summary of tensile test results.

Material System	Average σ_f Standard Deviation (psi)		Average E_o (psi)	Average ϵ_f (in/in)	Average Poisson's Ratio
	Nylon series 1	7160	533	NA	NA
Nylon series 2	7484	449	890,000	0.013	0.4
Nylon series 3	8220	882	812,000	0.018	0.45
ULTEM extruded	21525	1550	1,000,000	0.031	0.3
ULTEM injection molded	17340	869	1,048,000	0.024	0.35
Urethane [0°] ₁₀	51870 ^a	5106	6,100,000	End tab failure occurs before 0.01	0.4 (parallel to lamina)
Urethane [90°] ₁₀	811	130	39,900	0.45	0.05 (parallel to lamina)
Urethane [±45°] ₅	8727 ^a	488	60,600	0.42	1.0 (parallel to lamina)
Urethane [0°/90°] ₅	15822 ^a	968	1,754,000	End failure occurs before 0.01	0.25 (parallel to lamina)

^a Value is not the true failure stress.

Note: NA = not available.

Table 3. Summary of residual strain after loading/elastic recovery.

Material	Nylon/Glass	ULTEM/Glass	Urethane [90°] (%)	Urethane [45°] (%)
Residual plastic strain	0.3%	0.2%	1.6	1.0
Unloaded form	90% fail load/ 1.4% strain	90% fail load/ 2% strain	4.6	4.5

Series 2 was fitted with strain gages, and stress-strain results are shown in figure 2. The samples had 0.75-in fiberglass/epoxy end tabs bonded with a common quick-set epoxy. Specimens 1 and 2 in figure 2 show drops in stress that correspond to the end tabs pulling away from the samples. The samples did not have transverse strain gages, so Poisson’s effect was not measured.

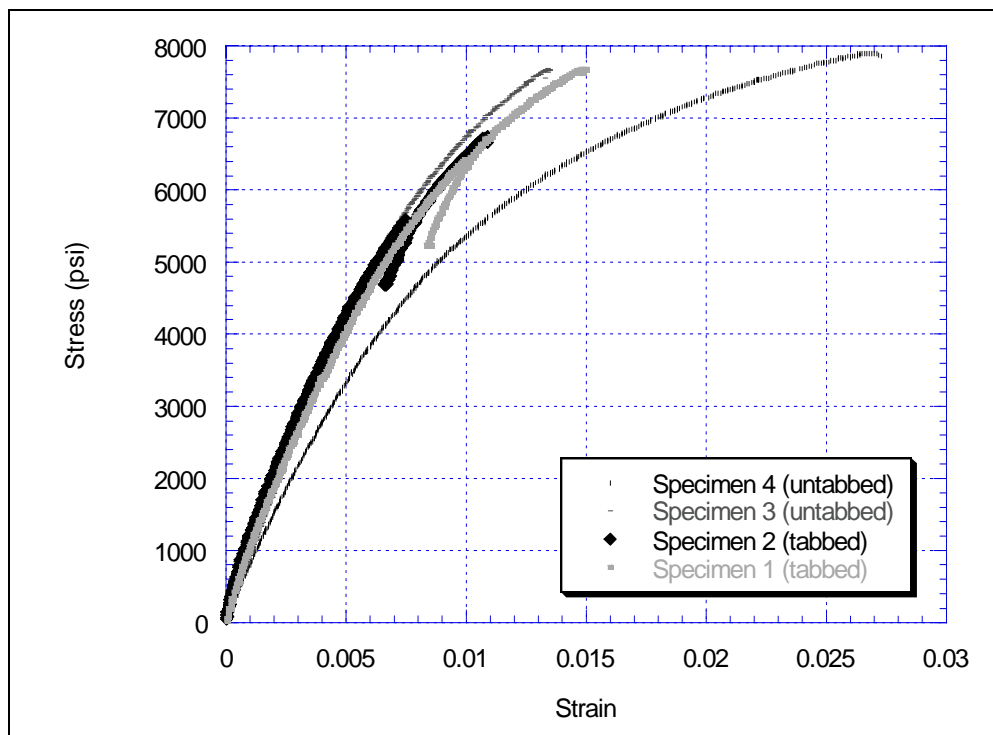

Figure 2. Illustration of tensile specimen sectioning from sample tubes and radial coordinate system with respect to tube arc.

To prevent the end tabs from pulling away, Hysol structural adhesive was used in series 3 tests. Despite this, the material did not strain greater than 2%. Biaxial strain gages accurate up to 5% were mounted on specimens, allowing the Poisson’s ratio results in figure 3. The samples were also loaded and unloaded incrementally to measure residual plastic strain after loading, as shown in figure 4.

Some fiberglass/Nylon 12 specimens were tested using emory cloth, as recommended by the American Society for Testing and Materials. Failure loads from these tests compared favorably to tests performed using end tabs. Also, the end-tabbed samples did not show a preference for

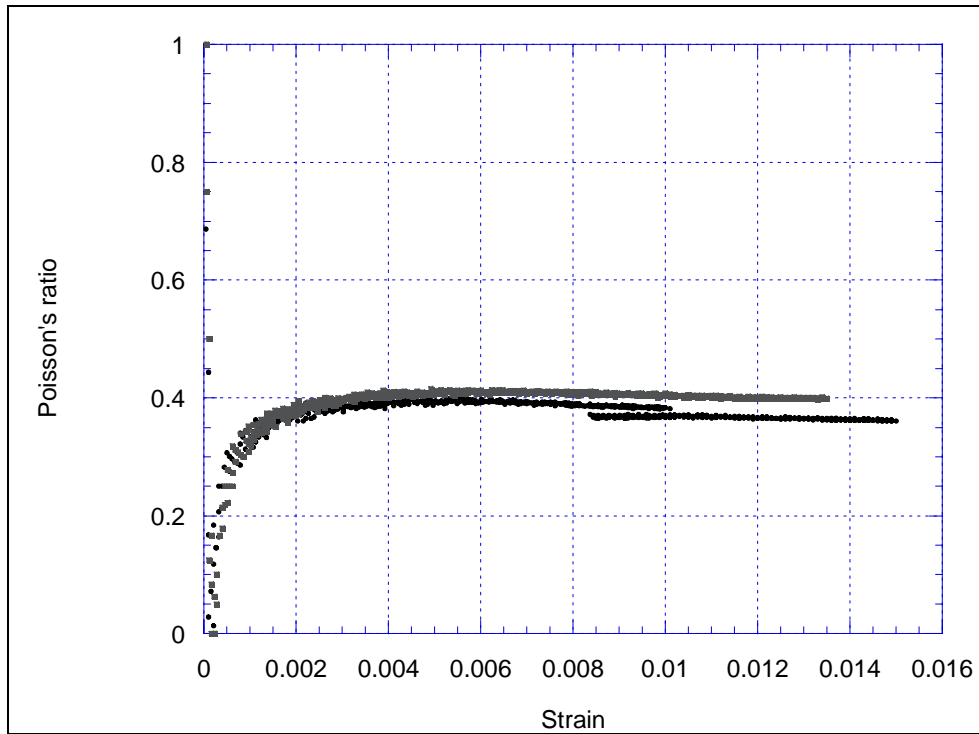

Figure 3. Examples of Poisson's ratio behavior of Nylon 12 material.

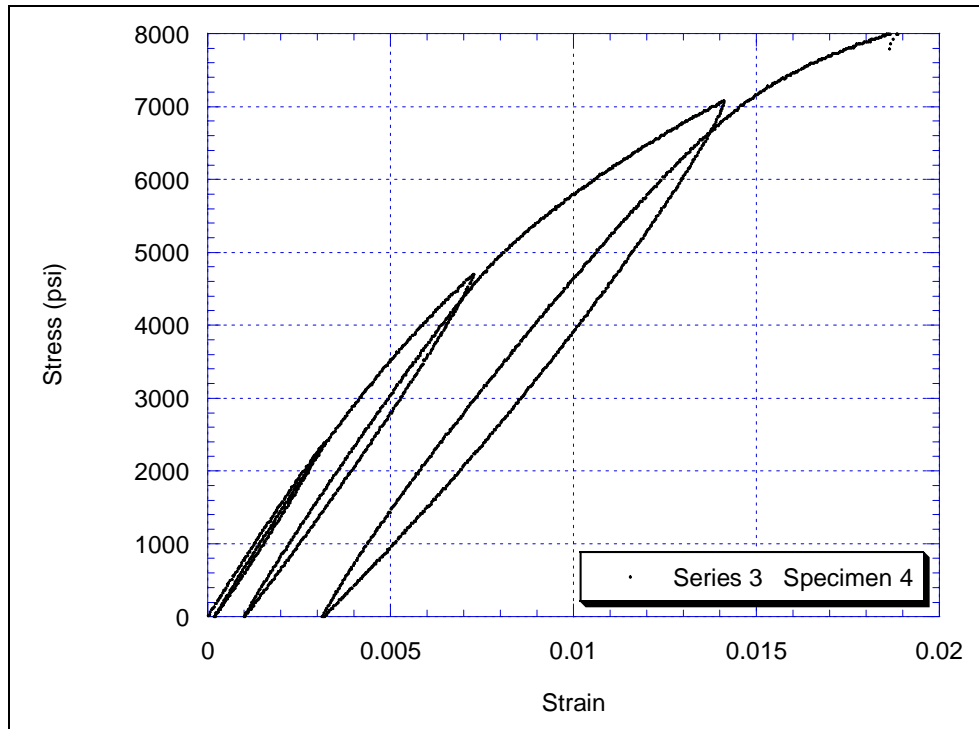

Figure 4. Example of load/unload of Nylon 12 material for residual strain characteristics.

where failure occurred, with samples failing both in the gage section and at the end tabs. This trend was also observed in the tests using the emory cloth.

Commercial data sheets on similar materials report strengths of ~20 ksi. The discrepancy between current tests and published data may be due to manufacturing differences. It has been suggested that preferential fiber alignments, which can occur easily in thin-walled injection molded parts, do not occur throughout a thicker part, such as the 0.375-in thick tube supplied for this study. Microscopy performed on the fiberglass/Nylon 12 material shows varied fiber alignment, as seen in figure 5. Some alignment occurs in the injection direction (longitudinal tube directions) near the walls of the mold. The alignment of fibers found near the inner wall can be seen to diminish to near random closer to the center of the thickness. In an effort to preserve fiber alignment, the series 3 tests employed specimens that were carefully sectioned directly from an arc section of tube. The results of this last series showed negligible benefit as a result of this method. In general, the occasional irregularities between similar specimens may be due to irregularities in the dispersion and orientation of fibers that can occur during mixing and injection.

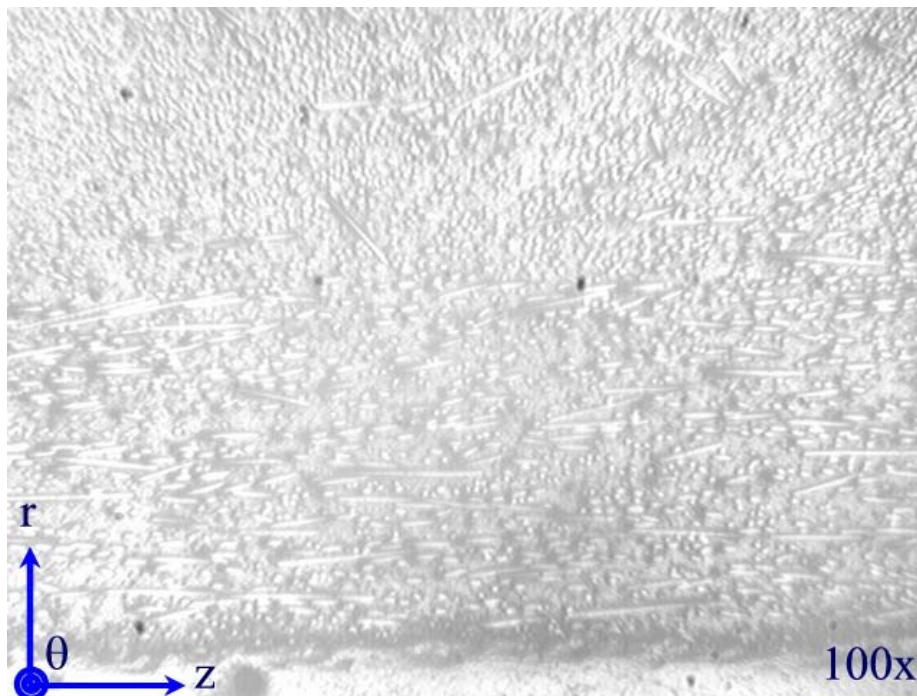

Figure 5. Micrograph of Nylon 12 material where alignment can be seen near tube inner wall in longitudinal direction. View is looking into the “theta” direction.

3.2 The 30% Fiberglass/ULTEM

Two tubes of the 30% chopped fiberglass/ULTEM were tested in this study. The first tube was machined from an extruded section. The second tube was injection molded to shape, with no

post-molding machining. This allowed for the effects of processing to be evaluated in regards to material properties.

3.2.1 Extruded Fiberglass/ULTEM

The extruded 30% chopped fiberglass/ULTEM was supplied as a 6-in long tube of 5.5-in diameter, with a 0.25-in wall thickness with end-seal chevrons. The samples were prepared using the previously outlined method, except the chevrons on the end were removed. The ultimate strength of this material is 21.5 ksi, with an initial modulus of 1 to 1.1 Msi, making it slightly stiffer but over twice as strong as the fiberglass/Nylon 12 samples. The strain capability of this system is also significantly better with a 3.1% strain to failure. The stress-strain response is similar to the fiberglass/Nylon 12, exhibiting nonlinear softening to a clean break, as shown in figure 6.

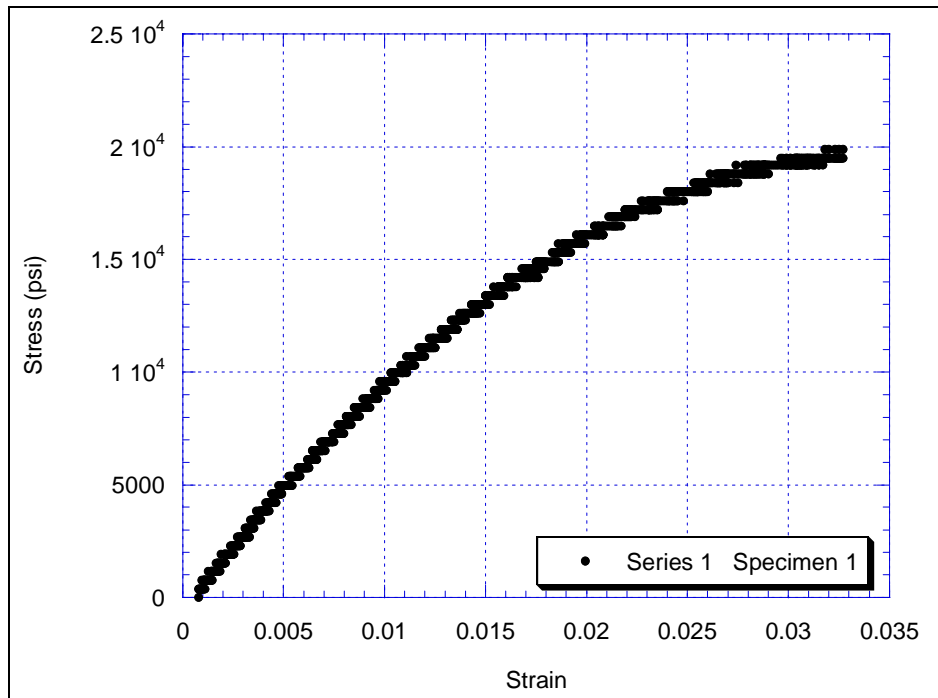

Figure 6. Representative example of extruded/machined ULTEM series results.

3.2.2 Injection-Molded Fiberglass/ULTEM

The injection-molded tube had a 6-in diameter and a 0.375-in wall thickness. Samples were prepared and tested with the method outlined for the fiberglass/Nylon 12 tube. The stress-strain results from the tension tests are shown in figure 7. The plastic strain is measured from a load/unload test. The stress-strain behavior is similar to the extruded material, but the failure properties differ. The ultimate stress is 18 ksi, and strain-to-failure is 2.4%. Both properties are lower than for the extruded version of the ULTEM material. The Poisson's ratio graph in figure 8 shows the slight difference in transverse behavior between the two types of ULTEM samples.

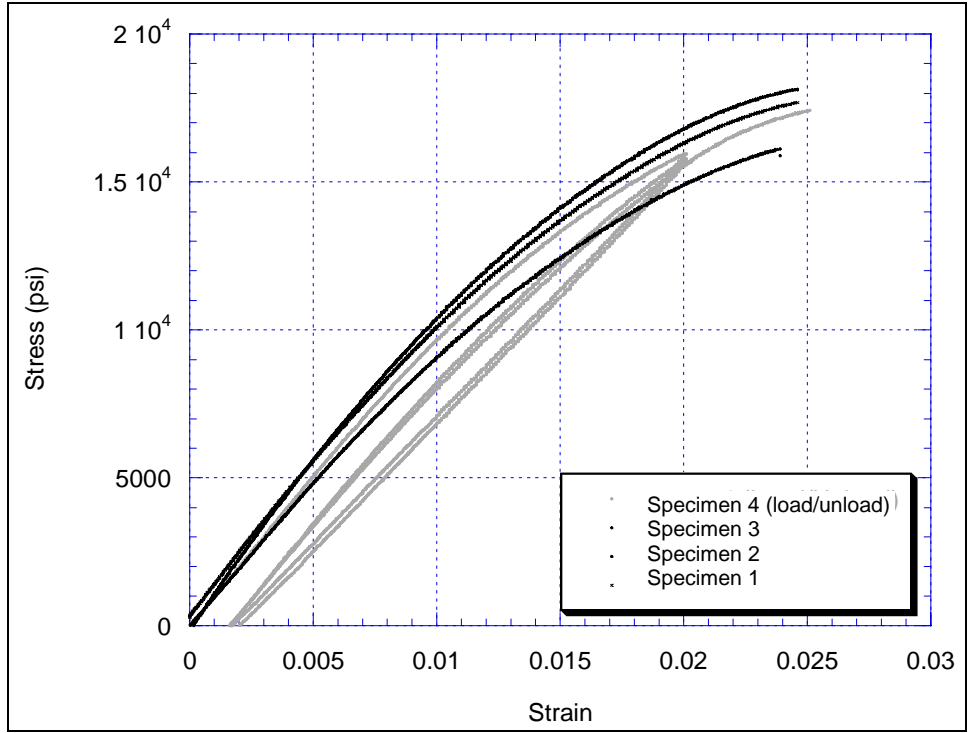

Figure 7. Summary of injection molded ULTEM series results.

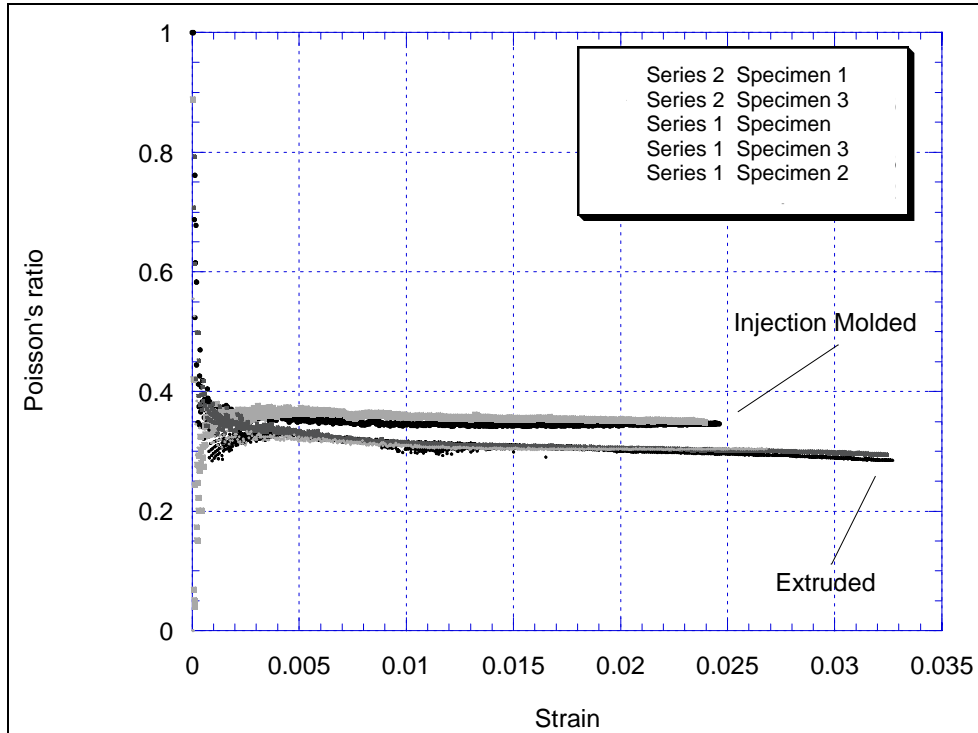

Figure 8. Summary of Poisson's ratio behavior of both ULTEM series.

3.3 Fiberglass/Urethane

A continuous fiberglass/urethane composite was also examined as a candidate cartridge case material. Four different lay-ups were tested— $[0^\circ]_5$, $[90^\circ]_{10}$, $[\pm 45^\circ]_5$, and $[0^\circ/90^\circ]_5$. These lay-ups allowed the characterization of the longitudinal, transverse, and shear properties.

3.3.1 $[0^\circ]_5$ Fiberglass/Urethane

The stress-strain results from tension tests on the $[0^\circ]_5$ samples are shown in figure 9. Since the behavior of the samples is governed by the glass fibers, the stress-strain relation is basically linear, with a modulus of 6.1 Msi. The average ultimate stress is 51.8 ksi, but it should be noted that all of the samples failed at the ends with the same characteristic pattern. The self-tightening action of the Instron grips squeezed out the material between the end tabs. The end tabs pulled off, tearing out a section of the sample. A different end-tabbing scheme is required to measure actual ultimate strength. The transverse behavior is mainly due to the properties of the rubber, as evident in figure 10 where Poisson's ratio approaches 0.5.

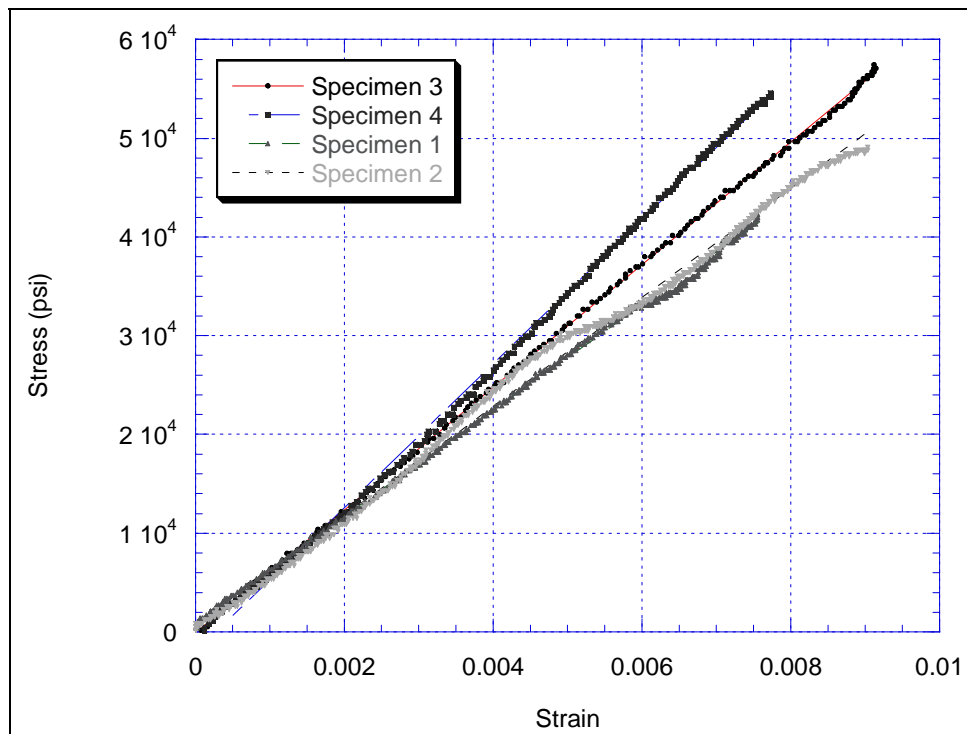

Figure 9. Summary of $[0^\circ]_5$ urethane response obtained prior to end tab debond.

3.3.2 $[90^\circ]_{10}$ Fiberglass/Urethane

The properties of the $[90^\circ]_{10}$ samples are now primarily due to the rubber, with no reinforcement in the test direction. The stress-strain results are shown in figure 11, indicating a high degree of nonlinear flattening of the curve. The plot is not indicative of the failure strains, which

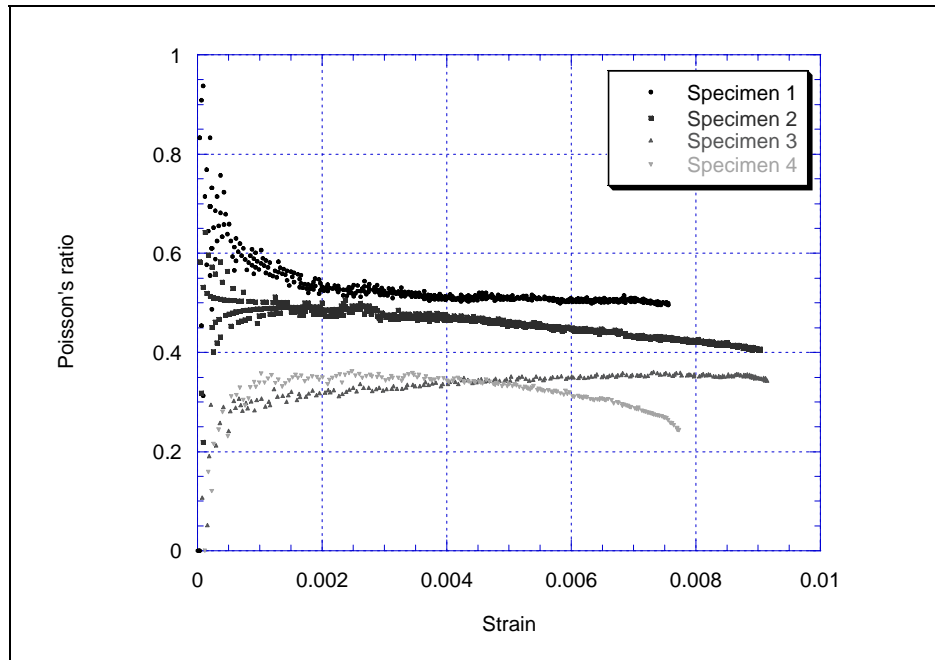

Figure 10. Poisson's ratio behavior of $[0^\circ]_5$ urethane series specimens.

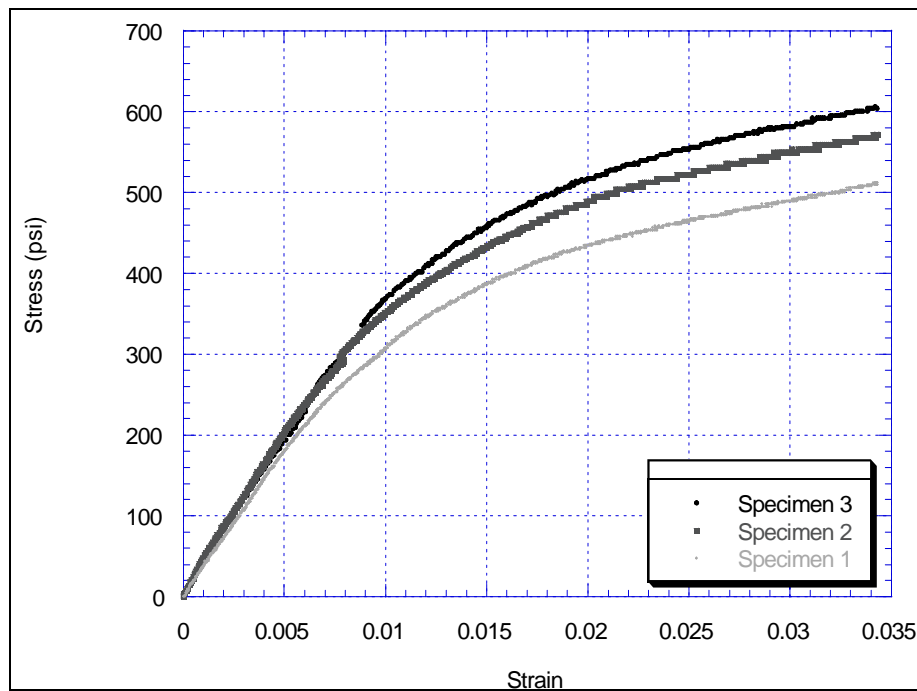

Figure 11. Initial portion of $[90^\circ]_{10}$ urethane response. Strains exceeded gage capabilities, while loads remained low until failure.

approached 50%, because the strain gages used have a maximum strain capacity of 5%. The stress never became greater than 1 ksi. At higher strains, striations between fiber bundles became apparent on the outer surfaces until the specimens failed. Because of the transverse fibers, lateral contraction was limited, as evident in figure 12, which shows the transverse Poisson’s ratio behavior of the $[90^\circ]_{10}$.

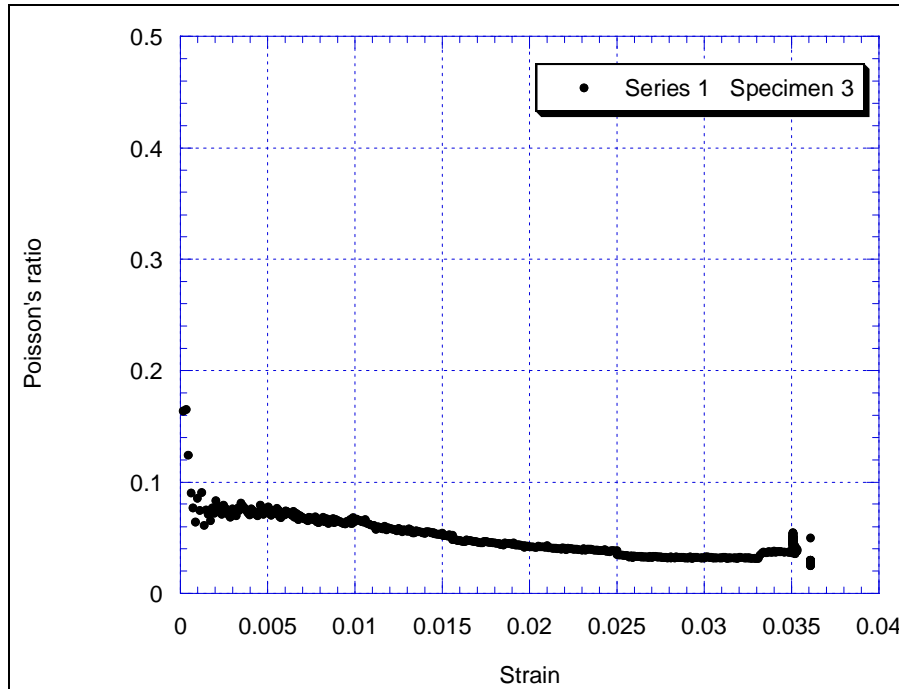

Figure 12. Example of Poisson’s ratio behavior of a $[90^\circ]_{10}$ urethane specimen. Strain gage measured lateral contraction on outer ply face, which was resisted by the alignment of the fibers in this direction. Through-thickness behavior is not represented and may differ significantly.

3.3.3 $[\pm 45^\circ]_5$ Fiberglass/Urethane

The next lay-up tested with the fiberglass/urethane materials was a $[\pm 45^\circ]_5$. Figure 13 shows the tensile response of a test sample. This specific lay-up allows the shear properties (G_{12} , τ_{ult}) to be measured through tension. To determine the shear stress-shear strain curves, the tensile response is transformed to the shear response using the relations $\tau_{shear} = \frac{\sigma_x}{2}$ and $\gamma_{shear} = |\epsilon_x| + |\epsilon_y|$.

Figure 14 shows the data from a test converted to shear components. This particular configuration exhibits a “scissoring” dominated mode of contraction, tending to rotate fibers into the test direction. A directional Poisson’s ratio this large would suggest a negative ration in the through-thickness direction, correlating with the observed behavior of the cross section of the samples. Expansion in the thickness direction and high Poisson in the lateral direction produced a rounded cross section from a rectangular one.

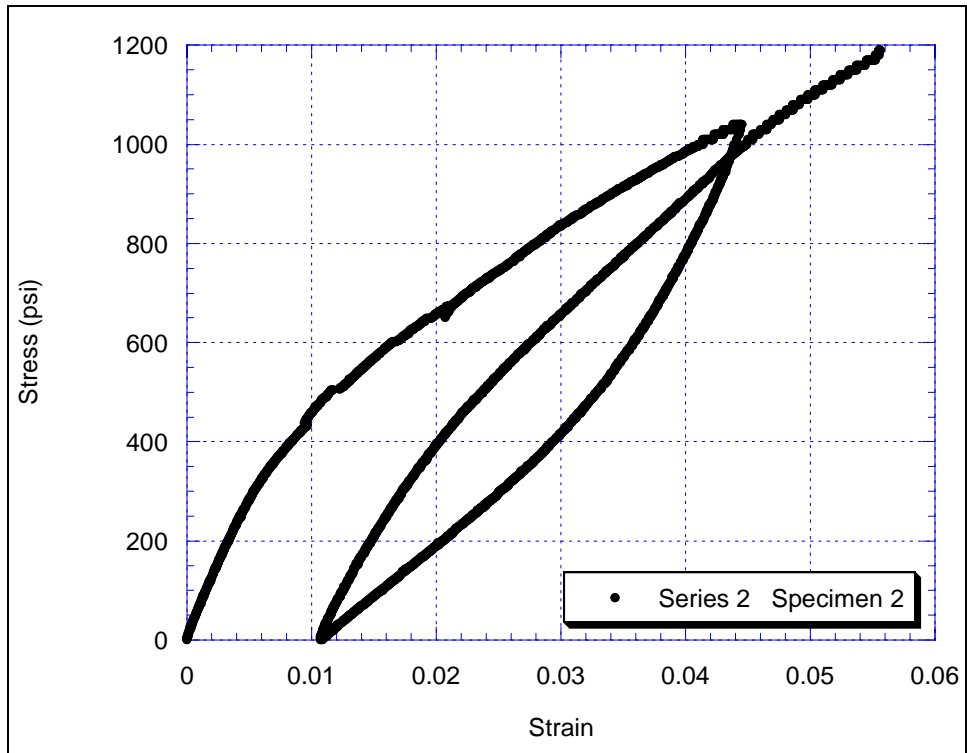

Figure 13. Tensile response of a $[\pm 45^\circ]_{10}$ coupon.

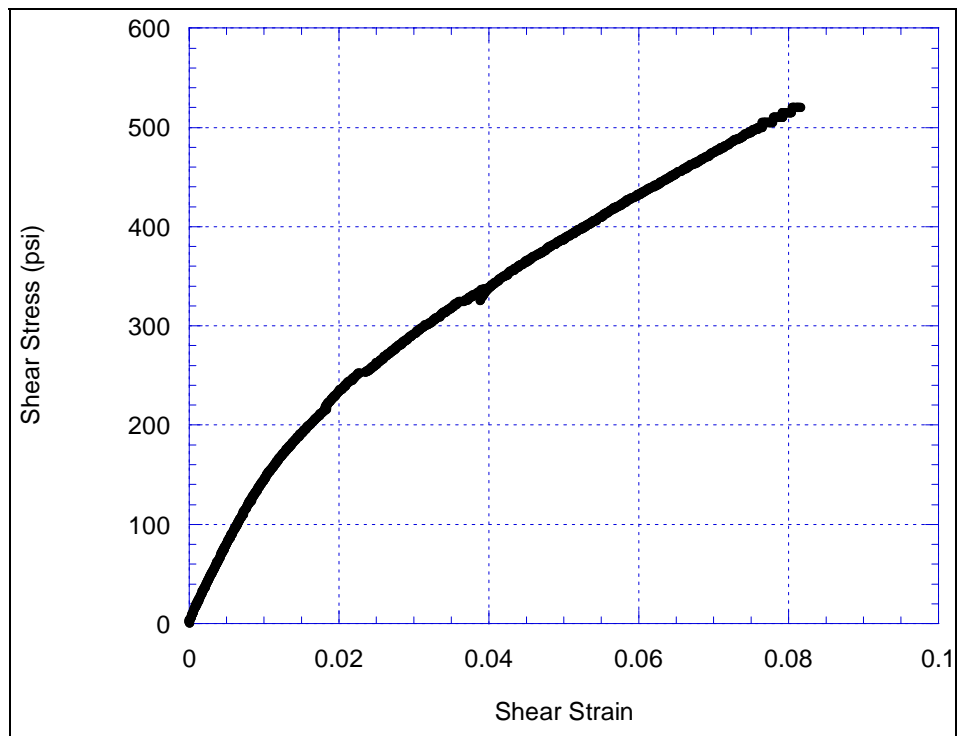

Figure 14. Reduction of $[\pm 45^\circ]_{10}$ tensile data into shear coordinate system.

The initial shear modulus is ~15 ksi. The maximum loads achieved are not representative of the ultimate because of the type of failure observed. At the end tabs, a ply-by-ply failure was observed as outer plies appeared to tear off. This suggests that even higher loads are possible if end effects are effectively neutralized. A Poisson's ratio near 1, evident in figure 15, demonstrates the high transverse contraction of this lay-up, which is due to the "scissoring" action of the fibers as they rotate into the test direction.

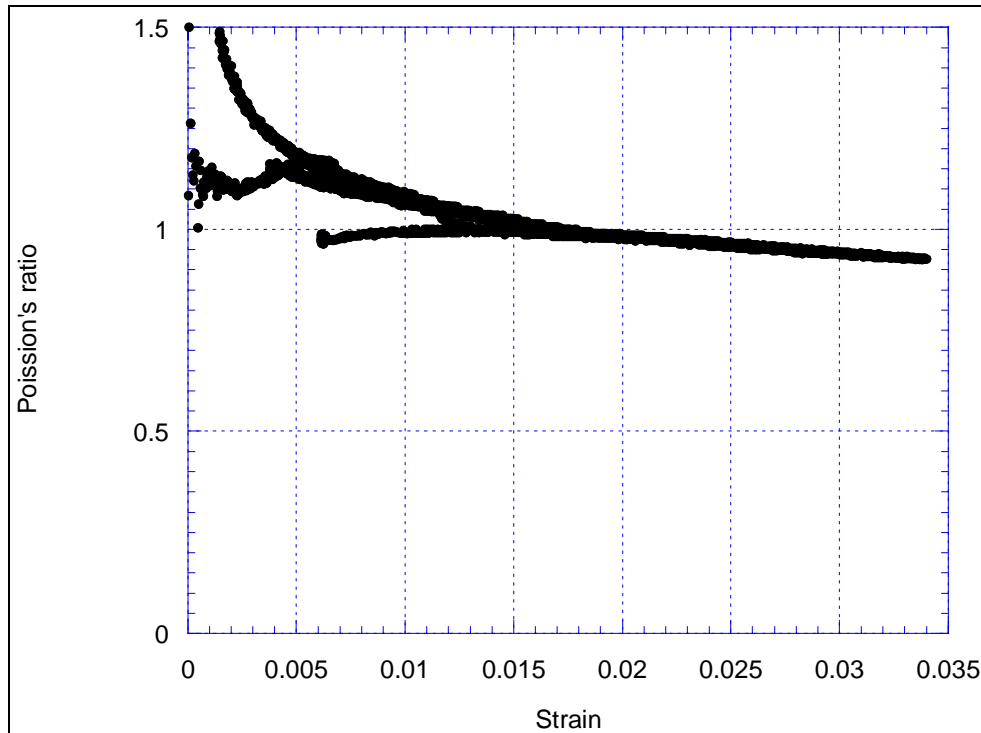

Figure 15. Apparent Poisson's ratio behavior on outer ply face of a $[\pm 45^\circ]_{10}$ specimen.

3.3.4 $[0^\circ/90^\circ]_5$ Fiberglass/Urethane

The final fiberglass/urethane combination tested was a $[0^\circ/90^\circ]_5$ lay-up. These specimens were placed directly into the grips of the testing machine, with no end tabs. The stress-strain results are shown in figure 16, and the Poisson's ratio results are shown in figure 17.

Until failure, the samples displayed approximate linear behavior, with a modulus of ~1.8 Msi. Ply-level failure of the outer $[0^\circ]$ ply occurred at ~12 ksi. This is most likely from the stress concentration at the grips, causing the fibers in the outer ply to fail. Instead of the opposite $[90^\circ]$ face, the strain gage was mounted on this same $[0^\circ]$ face because of a better bonding surface. When the $[0^\circ]$ outer ply failed, it became partially unloaded, causing the strain to decrease (represented by the erratic behavior of the stress-strain curve above 12 ksi). The remainder of the laminate stayed intact and carried a higher load. To obtain the true ultimate characteristics of this lay-up, an effective end-tabling scheme is again required.

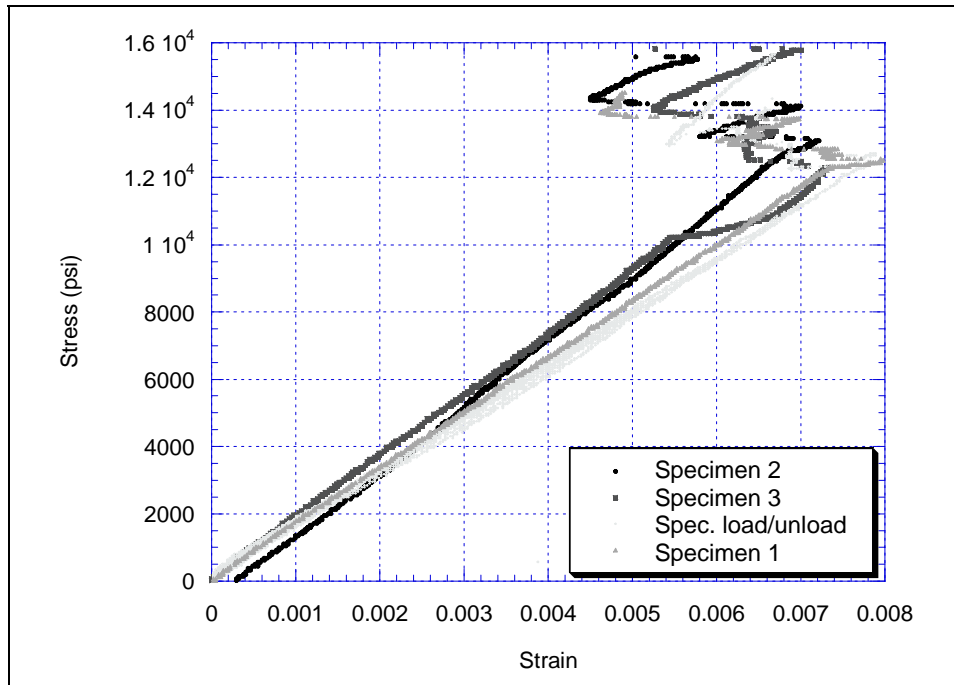

Figure 16. Stress-strain data reduced from $[0^\circ/90^\circ]_{10}$ tests. Odd failure region results from strain gage being mounted on outer 0° ply, which failed prior to catastrophic specimen failure. This ply partially relaxed before specimens went on to a slightly higher load.

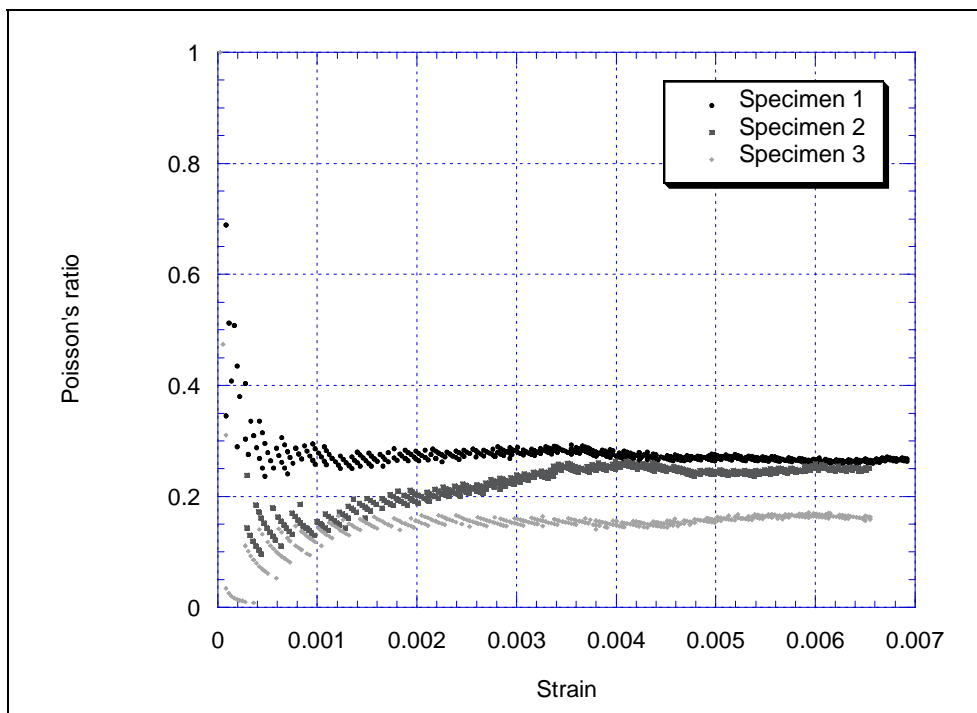

Figure 17. Observed Poisson's ratio behavior on outer 0° ply of $[0^\circ/90^\circ]_{10}$ samples.

It should be noted that after the initial outer [0°] ply failure and marginally increased load, all [0°] plies failed completely, as could be expected in comparison to the compliant [90°] plies. The interesting characteristic of this particular lay-up is that even after complete failure of the [0°] plies, the [90°] plies kept the coupon in one piece.

4. Conclusions

Three composite material systems, 50% chopped fiberglass/Nylon 12, 30% chopped fiberglass/ULTEM, and continuous fiberglass/urethane, were tested in order to determine basic material properties and suitability as candidates for use in the cartridge case for the CTA of the MRAAS 105-mm gun. The shape of the stress-strain curve, moduli, Poisson's ratio, failure stress and strain, and residual plastic deformation after unloading were determined. The results are presented graphically and in tabular form. These material properties are required to understand the mechanical response of the case to the loading cycle and to support the finite-element modeling of the case/chamber.

Finite-element analysis of the cartridge case in the chamber of the MRAAS swing chamber gun during a firing cycle will be presented in a separate report.⁴ These analyses confirm the intuitive feeling that strength and stiffness in this case are superfluous; the gun chamber supports the load created by the high-propellant gas pressure. The most important characteristics for the case material are its ability to go to high levels of failure strain (especially in the vicinity of the discontinuation near the end seals) and to suffer minimal residual plastic strain after a firing cycle.

⁴Powers, B.; Bogetti, T.; Drysdale, W. *Finite Element Analysis of a Composite Cartridge Case in the Multi-Role Armament and Ammunition System Gun*. U.S. Army Research Laboratory: Aberdeen Proving Ground, MD, to be published.

NO. OF
COPIES ORGANIZATION

1 DEFENSE TECHNICAL
(PDF INFORMATION CTR
ONLY) DTIC OCA
8725 JOHN J KINGMAN RD
STE 0944
FT BELVOIR VA 22060-6218

1 US ARMY RSRCH DEV &
ENGRG CMD
SYSTEMS OF SYSTEMS
INTEGRATION
AMSRD SS T
6000 6TH ST STE 100
FORT BELVOIR VA 22060-5608

1 INST FOR ADVNCD TCHNLGY
THE UNIV OF TEXAS
AT AUSTIN
3925 W BRAKER LN STE 400
AUSTIN TX 78759-5316

1 US MILITARY ACADEMY
MATH SCI CTR EXCELLENCE
MADN MATH
THAYER HALL
WEST POINT NY 10996-1786

1 DIRECTOR
US ARMY RESEARCH LAB
IMNE AD IM DR
2800 POWDER MILL RD
ADELPHI MD 20783-1197

3 DIRECTOR
US ARMY RESEARCH LAB
AMSRD ARL CI OK TL
2800 POWDER MILL RD
ADELPHI MD 20783-1197

3 DIRECTOR
US ARMY RESEARCH LAB
AMSRD ARL CS IS T
2800 POWDER MILL RD
ADELPHI MD 20783-1197

NO. OF
COPIES ORGANIZATION

ABERDEEN PROVING GROUND

1 DIR USARL
AMSRD ARL CI OK TP (BLDG 4600)

NO. OF
COPIES ORGANIZATION

1 DIRECTOR
US ARMY RESEARCH LAB
AMSRD ARL SE L
D SNIDER
2800 POWDER MILL RD
ADELPHI MD 20783-1197

1 DIRECTOR
US ARMY RESEARCH LAB
AMSRD ARL SE DE
R ATKINSON
2800 POWDER MILL RD
ADELPHI MD 20783-1197

5 DIRECTOR
US ARMY RESEARCH LAB
AMSRD ARL WM MB
A ABRAHAMIAN
M BERMAN
M CHOWDHURY
T LI
E SZYMANSKI
2800 POWDER MILL RD
ADELPHI MD 20783-1197

1 COMMANDER
US ARMY MATERIEL CMD
AMXMI INT
5001 EISENHOWER AVE
ALEXANDRIA VA 22333-0001

2 PM MAS
SFAE AMO MAS MC
PICATINNY ARSENAL NJ
07806-5000

3 COMMANDER
US ARMY ARDEC
AMSTA AR CC
M PADGETT
J HEDDERICH
H OPAT
PICATINNY ARSENAL NJ
07806-5000

2 COMMANDER
US ARMY ARDEC
AMSTA AR AE WW
E BAKER
J PEARSON
PICATINNY ARSENAL NJ
07806-5000

NO. OF
COPIES ORGANIZATION

1 COMMANDER
US ARMY ARDEC
AMSTA AR FSE
PICATINNY ARSENAL NJ
07806-5000

1 COMMANDER
US ARMY ARDEC
AMSTA AR TD
PICATINNY ARSENAL NJ
07806-5000

13 COMMANDER
US ARMY ARDEC
AMSTA AR CCH A
F ALTAMURA
M NICOLICH
M PALATHINGUL
D VO
R HOWELL
A VELLA
M YOUNG
L MANOLE
S MUSALLI
R CARR
M LUCIANO
E LOGSDEN
T LOUZEIRO
PICATINNY ARSENAL NJ
07806-5000

1 COMMANDER
US ARMY ARDEC
AMSTA AR CCH P
J LUTZ
PICATINNY ARSENAL NJ
07806-5000

1 COMMANDER
US ARMY ARDEC
AMSTA AR FSF T
C LIVECCHIA
PICATINNY ARSENAL NJ
07806-5000

1 COMMANDER
US ARMY ARDEC
AMSTA ASF
PICATINNY ARSENAL NJ
07806-5000

<u>NO. OF COPIES</u>	<u>ORGANIZATION</u>
1	COMMANDER US ARMY ARDEC AMSTA AR QAC T C J PAGE PICATINNY ARSENAL NJ 07806-5000
1	COMMANDER US ARMY ARDEC AMSTA AR M D DEMELLA PICATINNY ARSENAL NJ 07806-5000
3	COMMANDER US ARMY ARDEC AMSTA AR FSA A WARNASH B MACHAK M CHIEFA PICATINNY ARSENAL NJ 07806-5000
2	COMMANDER US ARMY ARDEC AMSTA AR FSP G M SCHIKSNIS D CARLUCCI PICATINNY ARSENAL NJ 07806-5000
2	COMMANDER US ARMY ARDEC AMSTA AR CCH C H CHANIN S CHICO PICATINNY ARSENAL NJ 07806-5000
1	COMMANDER US ARMY ARDEC AMSTA AR QAC T D RIGLIOSO PICATINNY ARSENAL NJ 07806-5000
1	COMMANDER US ARMY ARDEC AMSTA AR WET T SACHAR BLDG 172 PICATINNY ARSENAL NJ 07806-5000

<u>NO. OF COPIES</u>	<u>ORGANIZATION</u>
1	US ARMY ARDEC INTELLIGENCE SPECIALIST AMSTA AR WEL F M GUERRIERE PICATINNY ARSENAL NJ 07806-5000
10	COMMANDER US ARMY ARDEC AMSTA AR CCH B P DONADIA F DONLON P VALENTI C KNUTSON G EUSTICE K HENRY J MCNABOC G WAGNECZ R SAYER F CHANG PICATINNY ARSENAL NJ 07806-5000
6	COMMANDER US ARMY ARDEC AMSTA AR CCL F PUZYCKI R MCHUGH D CONWAY E JAROSZEWSKI R SCHLENNER M CLUNE PICATINNY ARSENAL NJ 07806-5000
1	PM ARMS SFAE GCSS ARMS BLDG 171 PICATINNY ARSENAL NJ 07806-5000
1	COMMANDER US ARMY ARDEC AMSTA AR WEA J BRESCIA PICATINNY ARSENAL NJ 07806-5000
1	PM MAS SFAE AMO MAS PICATINNY ARSENAL NJ 07806-5000

NO. OF COPIES ORGANIZATION

- 1 PM MAS
SFAE AMO MAS
CHIEF ENGINEER
PICATINNY ARSENAL NJ
07806-5000
- 1 PM MAS
SFAE AMO MAS PS
PICATINNY ARSENAL NJ
07806-5000
- 2 PM MAS
SFAE AMO MAS LC
PICATINNY ARSENAL NJ
07806-5000
- 1 COMMANDER
US ARMY ARDEC
PRODUCTION BASE
MODERN ACTY
AMSMC PBM K
PICATINNY ARSENAL NJ
07806-5000
- 1 COMMANDER
US ARMY TACOM
PM COMBAT SYSTEMS
SFAE GCS CS
6501 ELEVEN MILE RD
WARREN MI 48397-5000
- 1 COMMANDER
US ARMY TACOM
AMSTA SF
WARREN MI 48397-5000
- 1 DIRECTOR
AIR FORCE RESEARCH LAB
MLLMD
D MIRACLE
2230 TENTH ST
WRIGHT PATTERSON AFB OH
45433-7817
- 1 OFC OF NAVAL RESEARCH
J CHRISTODOULOU
ONR CODE 332
800 N QUINCY ST
ARLINGTON VA 22217-5600
- 1 US ARMY CERL
R LAMPO
2902 NEWMARK DR
CHAMPAIGN IL 61822

NO. OF COPIES ORGANIZATION

- 1 COMMANDER
US ARMY TACOM
PM SURVIVABLE SYSTEMS
SFAE GCSS W GSI H
M RYZYI
6501 ELEVEN MILE RD
WARREN MI 48397-5000
- 1 COMMANDER
US ARMY TACOM
CHIEF ABRAMS TESTING
SFAE GCSS W AB QT
T KRASKIEWICZ
6501 ELEVEN MILE RD
WARREN MI 48397-5000
- 1 COMMANDER
WATERVLIET ARSENAL
SMCWV QAE Q
B VANINA
BLDG 44
WATERVLIET NY 12189-4050
- 1 TNG, DOC, & CBT DEV
ATZK TDD IRSA
A POMEY
FT KNOX KY 40121
- 2 HQ IOC TANK
AMMUNITION TEAM
AMSIO SMT
R CRAWFORD
W HARRIS
ROCK ISLAND IL 61299-6000
- 2 COMMANDER
US ARMY AMCOM
AVIATION APPLIED TECH DIR
J SCHUCK
FT EUSTIS VA 23604-5577
- 1 NSWC
DAHLGREN DIV CODE G06
DAHLGREN VA 22448
- 2 US ARMY CORPS OF ENGR
CERD C
T LIU
CEW ET
T TAN
20 MASSACHUSETTS AVE NW
WASHINGTON DC 20314

NO. OF
COPIES ORGANIZATION

1 US ARMY COLD REGIONS
RSCH & ENGRNG LAB
P DUTTA
72 LYME RD
HANOVER NH 03755

14 COMMANDER
US ARMY TACOM
AMSTA TR R
R MCCLELLAND
D THOMAS
J BENNETT
D HANSEN
AMSTA JSK
S GOODMAN
J FLORENCE
K IYER
D TEMPLETON
A SCHUMACHER
AMSTA TR D
D OSTBERG
L HINOJOSA
B RAJU
AMSTA CS SF
H HUTCHINSON
F SCHWARZ
WARREN MI 48397-5000

14 BENET LABS
AMSTA AR CCB
R FISCELLA
M SOJA
E KATHE
M SCAVULO
G SPENCER
P WHEELER
S KRUPSKI
J VASILAKIS
G FRIAR
R HASENBEIN
AMSTA CCB R
S SOPOK
E HYLAND
D CRAYON
R DILLON
WATERVLIET NY 12189-4050

1 USA SBCCOM PM SOLDIER SPT
AMSSB PM RSS A
J CONNORS
KANSAS ST
NATICK MA 01760-5057

NO. OF
COPIES ORGANIZATION

1 NSWC
TECH LIBRARY CODE 323
17320 DAHLGREN RD
DAHLGREN VA 22448

2 USA SBCCOM
MATERIAL SCIENCE TEAM
AMSSB RSS
J HERBERT
M SENNETT
KANSAS ST
NATICK MA 01760-5057

2 OFC OF NAVAL RESEARCH
D SIEGEL CODE 351
J KELLY
800 N QUINCY ST
ARLINGTON VA 22217-5660

1 NSWC
CRANE DIVISION
M JOHNSON CODE 20H4
LOUISVILLE KY 40214-5245

2 NSWC
U SORATHIA
C WILLIAMS CD 6551
9500 MACARTHUR BLVD
WEST BETHESDA MD 20817

2 COMMANDER
NSWC
CARDEROCK DIVISION
R PETERSON CODE 2020
M CRITCHFIELD CODE 1730
BETHESDA MD 20084

8 DIRECTOR
US ARMY NGIC
D LEITER MS 404
M HOLTUS MS 301
M WOLFE MS 307
S MINGLEDORF MS 504
J GASTON MS 301
W GSTATTENBAUER MS 304
R WARNER MS 305
J CRIDER MS 306
2055 BOULDERS RD
CHARLOTTESVILLE VA
22911-8318

<u>NO. OF</u> <u>COPIES</u>	<u>ORGANIZATION</u>
1	NAVAL SEA SYSTEMS CMD D LIESE 1333 ISAAC HULL AVE SE 1100 WASHINGTON DC 20376-1100
1	EXPEDITIONARY WARFARE DIV N85 F SHOUP 2000 NAVY PENTAGON WASHINGTON DC 20350-2000
8	US ARMY SBCCOM SOLDIER SYSTEMS CENTER BALLISTICS TEAM J WARD W ZUKAS P CUNNIFF J SONG MARINE CORPS TEAM J MACKIEWICZ BUS AREA ADVOCACY TEAM W HASKELL AMSSB RCP SS W NYKVIST S BEAUDOIN KANSAS ST NATICK MA 01760-5019
7	US ARMY RESEARCH OFC A CROWSON H EVERETT J PRATER G ANDERSON D STEPP D KISEROW J CHANG PO BOX 12211 RESEARCH TRIANGLE PARK NC 27709-2211
1	AFRL MLBC 2941 P ST RM 136 WRIGHT PATTERSON AFB OH 45433-7750
1	DIRECTOR LOS ALAMOS NATL LAB F L ADDESSIO T 3 MS 5000 PO BOX 1633 LOS ALAMOS NM 87545

<u>NO. OF</u> <u>COPIES</u>	<u>ORGANIZATION</u>
8	NSWC J FRANCIS CODE G30 D WILSON CODE G32 R D COOPER CODE G32 J FRAYSSE CODE G33 E ROWE CODE G33 T DURAN CODE G33 L DE SIMONE CODE G33 R HUBBARD CODE G33 DAHLGREN VA 22448
1	NSWC CARDEROCK DIVISION R CRANE CODE 6553 9500 MACARTHUR BLVD WEST BETHESDA MD 20817-5700
1	AFRL MLSS R THOMSON 2179 12TH ST RM 122 WRIGHT PATTERSON AFB OH 45433-7718
2	AFRL F ABRAMS J BROWN BLDG 653 2977 P ST STE 6 WRIGHT PATTERSON AFB OH 45433-7739
5	DIRECTOR LLNL R CHRISTENSEN S DETERESA F MAGNESS M FINGER MS 313 M MURPHY L 282 PO BOX 808 LIVERMORE CA 94550
1	AFRL MLS OL L COULTER 5851 F AVE BLDG 849 RM AD1A HILL AFB UT 84056-5713
1	OSD JOINT CCD TEST FORCE OSD JCCD R WILLIAMS 3909 HALLS FERRY RD VICKSBURG MS 29180-6199

NO. OF
COPIES ORGANIZATION

3 DARPA
M VANFOSSEN
S WAX
L CHRISTODOULOU
3701 N FAIRFAX DR
ARLINGTON VA 22203-1714

2 SERDP PROGRAM OFC
PM P2
C PELLERIN
B SMITH
901 N STUART ST STE 303
ARLINGTON VA 22203

1 OAK RIDGE NATL LAB
R M DAVIS
PO BOX 2008
OAK RIDGE TN 37831-6195

1 OAK RIDGE NATL LAB
C EBERLE MS 8048
PO BOX 2008
OAK RIDGE TN 37831

3 DIRECTOR
SANDIA NATL LABS
APPLIED MECHS DEPT
MS 9042
J HANDROCK
Y R KAN
J LAUFFER
PO BOX 969
LIVERMORE CA 94551-0969

1 OAK RIDGE NATL LAB
C D WARREN MS 8039
PO BOX 2008
OAK RIDGE TN 37831

4 NIST
M VANLANDINGHAM MS 8621
J CHIN MS 8621
J MARTIN MS 8621
D DUTHINH MS 8611
100 BUREAU DR
GAITHERSBURG MD 20899

1 HYDROGEOLOGIC INC
SERDP ESTCP SPT OFC
S WALSH
1155 HERNDON PKWY STE 900
HERNDON VA 20170

NO. OF
COPIES ORGANIZATION

3 NASA LANGLEY RESEARCH CTR
AMSRD ARL VS
W ELBER MS 266
F BARTLETT JR MS 266
G FARLEY MS 266
HAMPTON VA 23681-0001

1 NASA LANGLEY RESEARCH CTR
T GATES MS 188E
HAMPTON VA 23661-3400

1 FHWA
E MUNLEY
6300 GEORGETOWN PIKE
MCLEAN VA 22101

1 USDOT FEDERAL RAILROAD
M FATEH RDV 31
WASHINGTON DC 20590

3 CYTEC FIBERITE
R DUNNE
D KOHLI
R MAYHEW
1300 REVOLUTION ST
HAVRE DE GRACE MD 21078

1 DIRECTOR
NGIC
IANG TMT
2055 BOULDERS RD
CHARLOTTESVILLE VA
22911-8318

1 SIOUX MFG
B KRIEL
PO BOX 400
FT TOTTEN ND 58335

2 3TEX CORP
A BOGDANOVICH
J SINGLETARY
109 MACKENAN DR
CARY NC 27511

1 3M CORP
J SKILDUM
3M CENTER BLDG 60 IN 01
ST PAUL MN 55144-1000

NO. OF
COPIES ORGANIZATION

1 DIRECTOR
DEFENSE INTLLGNC AGENCY
TA 5
K CRELLING
WASHINGTON DC 20310

1 ADVANCED GLASS FIBER YARNS
T COLLINS
281 SPRING RUN LANE STE A
DOWNINGTON PA 19335

1 COMPOSITE MATERIALS INC
D SHORTT
19105 63 AVE NE
PO BOX 25
ARLINGTON WA 98223

1 JPS GLASS
L CARTER
PO BOX 260
SLATER RD
SLATER SC 29683

1 COMPOSITE MATERIALS INC
R HOLLAND
11 JEWEL CT
ORINDA CA 94563

1 COMPOSITE MATERIALS INC
C RILEY
14530 S ANSON AVE
SANTA FE SPRINGS CA 90670

2 SIMULA
J COLTMAN
R HUYETT
10016 S 51ST ST
PHOENIX AZ 85044

2 PROTECTION MATERIALS INC
M MILLER
F CRILLEY
14000 NW 58 CT
MIAMI LAKES FL 33014

2 FOSTER MILLER
M ROYLANCE
W ZUKAS
195 BEAR HILL RD
WALTHAM MA 02354-1196

NO. OF
COPIES ORGANIZATION

1 ROM DEVELOPMENT CORP
R O MEARA
136 SWINEBURNE ROW
BRICK MARKET PLACE
NEWPORT RI 02840

2 TEXTRON SYSTEMS
T FOLTZ
M TREASURE
1449 MIDDLESEX ST
LOWELL MA 01851

1 O GARA HESS & EISENHARDT
M GILLESPIE
9113 LESAINTE DR
FAIRFIELD OH 45014

2 MILLIKEN RESEARCH CORP
H KUHN
M MACLEOD
PO BOX 1926
SPARTANBURG SC 29303

1 CONNEAUGHT INDUSTRIES INC
J SANTOS
PO BOX 1425
COVENTRY RI 02816

1 ARMTEC DEFENSE PRODUCTS
S DYER
85 901 AVE 53
PO BOX 848
COACHELLA CA 92236

1 NATL COMPOSITE CTR
T CORDELL
2000 COMPOSITE DR
KETTERING OH 45420

3 PACIFIC NORTHWEST LAB
M SMITH
G VAN ARSDALE
R SHIPPELL
PO BOX 999
RICHLAND WA 99352

1 SAIC
M PALMER
1410 SPRING HILL RD STE 400
MS SH4 5
MCLEAN VA 22102

NO. OF
COPIES ORGANIZATION

1 ALLIANT TECHSYSTEMS INC
4700 NATHAN LN N
PLYMOUTH MN 55442-2512

1 APPLIED COMPOSITES
W GRISCH
333 NORTH SIXTH ST
ST CHARLES IL 60174

1 CUSTOM ANALYTICAL
ENG SYS INC
A ALEXANDER
13000 TENSOR LANE NE
FLINTSTONE MD 21530

1 AAI CORP
DR N B MCNELLIS
PO BOX 126
HUNT VALLEY MD 21030-0126

1 OFC DEPUTY UNDER SEC DEFNS
J THOMPSON
1745 JEFFERSON DAVIS HWY
CRYSTAL SQ 4 STE 501
ARLINGTON VA 22202

3 ALLIANT TECHSYSTEMS INC
J CONDON
E LYNAM
J GERHARD
WV01 16 STATE RT 956
PO BOX 210
ROCKET CENTER WV
26726-0210

1 PROJECTILE TECHNOLOGY INC
515 GILES ST
HAVRE DE GRACE MD 21078

1 HEXCEL INC
R BOE
PO BOX 18748
SALT LAKE CITY UT 84118

1 PRATT & WHITNEY
C WATSON
400 MAIN ST MS 114 37
EAST HARTFORD CT 06108

NO. OF
COPIES ORGANIZATION

5 NORTHROP GRUMMAN
B IRWIN
K EVANS
D EWART
A SHREKENHAMER
J MCGLYNN
BLDG 160 DEPT 3700
1100 WEST HOLLYVALE ST
AZUSA CA 91701

1 HERCULES INC
HERCULES PLAZA
WILMINGTON DE 19894

1 BRIGS COMPANY
J BACKOFEN
2668 PETERBOROUGH ST
HERNDON VA 22071-2443

1 ZERNOW TECHNICAL SERVICES
L ZERNOW
425 W BONITA AVE STE 208
SAN DIMAS CA 91773

1 GENERAL DYNAMICS OTS
L WHITMORE
10101 NINTH ST NORTH
ST PETERSBURG FL 33702

2 GENERAL DYNAMICS OTS
FLINCHBAUGH DIV
K LINDE
T LYNCH
PO BOX 127
RED LION PA 17356

1 GKN WESTLAND AEROSPACE
D OLDS
450 MURDOCK AVE
MERIDEN CT 06450-8324

2 BOEING ROTORCRAFT
P MINGURT
P HANDEL
800 B PUTNAM BLVD
WALLINGFORD PA 19086

NO. OF
COPIES ORGANIZATION

5 SIKORSKY AIRCRAFT
G JACARUSO
T CARSTENSAN
B KAY
S GARBO MS S330A
J ADELMANN
6900 MAIN ST
PO BOX 9729
STRATFORD CT 06497-9729

1 AEROSPACE CORP
G HAWKINS M4 945
2350 E EL SEGUNDO BLVD
EL SEGUNDO CA 90245

2 CYTEC FIBERITE
M LIN
W WEB
1440 N KRAEMER BLVD
ANAHEIM CA 92806

2 UDLP
G THOMAS
M MACLEAN
PO BOX 58123
SANTA CLARA CA 95052

1 UDLP WARREN OFC
A LEE
31201 CHICAGO RD SOUTH
SUITE B102
WARREN MI 48093

2 UDLP
R BRYNSVOLD
P JANKE MS 170
4800 EAST RIVER RD
MINNEAPOLIS MN 55421-1498

1 LOCKHEED MARTIN
SKUNK WORKS
D FORTNEY
1011 LOCKHEED WAY
PALMDALE CA 93599-2502

1 LOCKHEED MARTIN
R FIELDS
5537 PGA BLVD
SUITE 4516
ORLANDO FL 32839

NO. OF
COPIES ORGANIZATION

1 NORTHRUP GRUMMAN CORP
ELECTRONIC SENSORS
& SYSTEMS DIV
E SCHOCH MS V 16
1745A W NURSERY RD
LINTHICUM MD 21090

1 GDLS DIVISION
D BARTLE
PO BOX 1901
WARREN MI 48090

2 GDLS
D REES
M PASIK
PO BOX 2074
WARREN MI 48090-2074

1 GDLS
MUSKEGON OPER
M SOIMAR
76 GETTY ST
MUSKEGON MI 49442

1 GENERAL DYNAMICS
AMPHIBIOUS SYS
SURVIVABILITY LEAD
G WALKER
991 ANNAPOLIS WAY
WOODBIDGE VA 22191

6 INST FOR ADVANCED
TECH
H FAIR
I MCNAB
P SULLIVAN
S BLESS
W REINECKE
C PERSAD
3925 W BRAKER LN STE 400
AUSTIN TX 78759-5316

1 ARROW TECH ASSOC
1233 SHELBURNE RD STE D8
SOUTH BURLINGTON VT
05403-7700

1 R EICHELBERGER
CONSULTANT
409 W CATHERINE ST
BEL AIR MD 21014-3613

<u>NO. OF</u> <u>COPIES</u>	<u>ORGANIZATION</u>
1	SAIC G CHRYSSOMALLIS 8500 NORMANDALE LAKE BLVD SUITE 1610 BLOOMINGTON MN 55437-3828
1	UCLA MANE DEPT ENGR IV H T HAHN LOS ANGELES CA 90024-1597
2	UNIV OF DAYTON RESEARCH INST R Y KIM A K ROY 300 COLLEGE PARK AVE DAYTON OH 45469-0168
1	UMASS LOWELL PLASTICS DEPT N SCHOTT 1 UNIVERSITY AVE LOWELL MA 01854
1	IIT RESEARCH CTR D ROSE 201 MILL ST ROME NY 13440-6916
1	GA TECH RESEARCH INST GA INST OF TCHNLGY P FRIEDERICH ATLANTA GA 30392
1	MICHIGAN ST UNIV MSM DEPT R AVERILL 3515 EB EAST LANSING MI 48824-1226
1	UNIV OF WYOMING D ADAMS PO BOX 3295 LARAMIE WY 82071
1	PENN STATE UNIV R S ENGEL 245 HAMMOND BLDG UNIVERSITY PARK PA 16801

<u>NO. OF</u> <u>COPIES</u>	<u>ORGANIZATION</u>
2	PENN STATE UNIV R MCNITT C BAKIS 212 EARTH ENGR SCIENCES BLDG UNIVERSITY PARK PA 16802
1	PURDUE UNIV SCHOOL OF AERO & ASTRO C T SUN W LAFAYETTE IN 47907-1282
1	STANFORD UNIV DEPT OF AERONAUTICS & AEROBALLISTICS S TSAI DURANT BLDG STANFORD CA 94305
1	UNIV OF MAINE ADV STR & COMP LAB R LOPEZ ANIDO 5793 AEWB BLDG ORONO ME 04469-5793
1	JOHNS HOPKINS UNIV APPLIED PHYSICS LAB P WIENHOLD 11100 JOHNS HOPKINS RD LAUREL MD 20723-6099
1	UNIV OF DAYTON J M WHITNEY COLLEGE PARK AVE DAYTON OH 45469-0240
1	NORTH CAROLINA ST UNIV CIVIL ENGINEERING DEPT W RASDORF PO BOX 7908 RALEIGH NC 27696-7908
5	UNIV OF DELAWARE CTR FOR COMPOSITE MTRLS J GILLESPIE M SANTARE S YARLAGADDA S ADVANI D HEIDER 201 SPENCER LAB NEWARK DE 19716

NO. OF
COPIES ORGANIZATION

1 DEPT OF MTRLS
SCIENCE & ENGRG
UNIV OF ILLINOIS
AT URBANA CHAMPAIGN
J ECONOMY
1304 WEST GREEN ST 115B
URBANA IL 61801

1 UNIV OF MARYLAND
DEPT OF AEROSPACE ENGRG
A J VIZZINI
COLLEGE PARK MD 20742

1 DREXEL UNIV
A S D WANG
3141 CHESTNUT ST
PHILADELPHIA PA 19104

3 UNIV OF TEXAS AT AUSTIN
CTR FOR ELECTROMECHANICS
J PRICE
A WALLS
J KITZMILLER
10100 BURNET RD
AUSTIN TX 78758-4497

3 VA POLYTECHNICAL
INST & STATE UNIV
DEPT OF ESM
M W HYER
K REIFSNIDER
R JONES
BLACKSBURG VA 24061-0219

1 SOUTHWEST RESEARCH INST
ENGR & MATL SCIENCES DIV
J RIEGEL
6220 CULEBRA RD
PO DRAWER 28510
SAN ANTONIO TX 78228-0510

1 BATELLE NATICK OPERS
B HALPIN
313 SPEEN ST
NATICK MA 01760

3 DIRECTOR
US ARMY RESEARCH LAB
AMSRD ARL WM MB
A FRYDMAN
2800 POWDER MILL RD
ADELPHI MD 20783-1197

NO. OF
COPIES ORGANIZATION

ABERDEEN PROVING GROUND

1 US ARMY ATC
CSTE DTC AT AC I
W C FRAZER
400 COLLERAN RD
APG MD 21005-5059

91 DIR USARL
AMSRD ARL CI
AMSRD ARL O AP EG
M ADAMSON
AMSRD ARL SL BA
AMSRD ARL SL BB
D BELY
AMSRD ARL WM
J SMITH
H WALLACE
AMSRD ARL WM B
A HORST
T KOGLER
AMSRD ARL WM BA
D LYON
AMSRD ARL WM BC
J NEWILL
P PLOSTINS
A ZIELINSKI
AMSRD ARL WM BD
P CONROY
B FORCH
M LEADORE
C LEVERITT
R LIEB
R PESCE RODRIGUEZ
B RICE
AMSRD ARL WM BF
S WILKERSON
AMSRD ARL WM M
B FINK
J MCCAULEY
AMSRD ARL WM MA
L GHIORSE
S MCKNIGHT
E WETZEL
AMSRD ARL WM MB
J BENDER
T BOGETTI
L BURTON
R CARTER
K CHO
W DE ROSSET
G DEWING
R DOWDING
W DRYSDALE

NO. OF
COPIES ORGANIZATION

R EMERSON
D HENRY
D HOPKINS
R KASTE
L KECSKES
M MINNICINO
B POWERS
D SNOHA
J SOUTH
M STAKER
J SWAB
J TZENG
AMSRD ARL WM MC
J BEATTY
R BOSSOLI
E CHIN
S CORNELISON
D GRANVILLE
B HART
J LASALVIA
J MONTGOMERY
F PIERCE
E RIGAS
W SPURGEON
AMSRD ARL WM MD
B CHEESEMAN
P DEHMER
R DOOLEY
G GAZONAS
S GHORSE
C HOPPEL
M KLUSEWITZ
W ROY
J SANDS
D SPAGNUOLO
S WALSH
S WOLF
AMSRD ARL WM RP
J BORNSTEIN
C SHOEMAKER
AMSRD ARL WM T
B BURNS
AMSRD ARL WM TA
W BRUCHEY
M BURKINS
W GILLICH
B GOOCH
T HAVEL
E HORWATH
M NORMANDIA
J RUNYEON
M ZOLTOSKI

NO. OF
COPIES ORGANIZATION

AMSRD ARL WM TB
P BAKER
AMSRD ARL WM TC
R COATES
AMSRD ARL WM TD
D DANDEKAR
T HADUCH
T MOYNIHAN
M RAFTENBERG
S SCHOENFELD
T WEERASOORIYA
AMSRD ARL WM TE
A NILER
J POWELL

NO. OF
COPIES ORGANIZATION

1 LTD
R MARTIN
MERL
TAMWORTH RD
HERTFORD SG13 7DG
UK

1 SMC SCOTLAND
P W LAY
DERA ROSYTH
ROSYTH ROYAL DOCKYARD
DUNFERMLINE FIFE KY 11 2XR
UK

1 CIVIL AVIATION
ADMINSTRATION
T GOTTESMAN
PO BOX 8
BEN GURION INTRNL AIRPORT
LOD 70150
ISRAEL

1 AEROSPATIALE
S ANDRE
A BTE CC RTE MD132
316 ROUTE DE BAYONNE
TOULOUSE 31060
FRANCE

1 DRA FORT HALSTEAD
P N JONES
SEVEN OAKS KENT TN 147BP
UK

1 SWISS FEDERAL ARMAMENTS
WKS
W LANZ
ALLMENDSTRASSE 86
3602 THUN
SWITZERLAND

1 DYNAMEC RESEARCH LAB
AKE PERSSON
BOX 201
SE 151 23 SODERTALJE
SWEDEN

NO. OF
COPIES ORGANIZATION

1 ISRAEL INST OF TECHLGY
S BODNER
FACULTY OF MECHANICAL
ENGR
HAIFA 3200
ISRAEL

1 DSTO
WEAPONS SYSTEMS DIVISION
N BURMAN RLLWS
SALISBURY
SOUTH AUSTRALIA 5108
AUSTRALIA

1 DEF RES ESTABLISHMENT
VALCARTIER
A DUPUIS
2459 BLVD PIE XI NORTH
VALCARTIER QUEBEC
CANADA
PO BOX 8800 COURCELETTE
GOA IRO QUEBEC
CANADA

1 ECOLE POLYTECH
J MANSON
DMX LTC
CH 1015 LAUSANNE
SWITZERLAND

1 TNO DEFENSE RESEARCH
R IJSSELSTEIN
ACCOUNT DIRECTOR
R&D ARMEE
PO BOX 6006
2600 JA DELFT
THE NETHERLANDS

2 FOA NATL DEFENSE RESEARCH
ESTAB
DIR DEPT OF WEAPONS &
PROTECTION
B JANZON
R HOLMLIN
S 172 90 STOCKHOLM
SWEDEN

NO. OF
COPIES ORGANIZATION

- 2 DEFENSE TECH & PROC
AGENCY GROUND
I CREWTHER
GENERAL HERZOG HAUS
3602 THUN
SWITZERLAND

- 1 MINISTRY OF DEFENCE
RAFAEL
ARMAMENT DEVELOPMENT
AUTH
M MAYSELESS
PO BOX 2250
HAIFA 31021
ISRAEL

- 1 TNO DEFENSE RESEARCH
I H PASMAN
POSTBUS 6006
2600 JA DELFT
THE NETHERLANDS

- 1 B HIRSCH
TACHKEMONY ST 6
NETAMUA 42611
ISRAEL

- 1 DEUTSCHE AEROSPACE AG
DYNAMICS SYSTEMS
M HELD
PO BOX 1340
D 86523 SCHROBENHAUSEN
GERMANY

INTENTIONALLY LEFT BLANK.