

High Performance Embedded Computing Workshop at MIT/LL (23-25 September 2003)

1. Title: Hybrid Optical/Digital Processor for Radar Imaging

2. Authors:

Mr. Keith Frampton
Essex Corporation
9150 Guilford Road
Columbia, MD 21046
301-953-7875
301-953-7880 (fax)
Frampton@EssexCorp.com
US Citizen

Mr. Patrick Stover
Annapolis Micro Systems, Inc.
190 Admiral Cochrane Dr.
Suite 130
Annapolis, MD 21401
410-841-2514
410-841-2518 (fax)
patrick.stover@annapmicro.com
US Citizen

3. Author notation:

First:	Mr. Keith Frampton
Corresponding:	Mr. Patrick Stover
Presenting:	Mr. Keith Frampton

4. Presentation session:

Presentation does not need to be limited to the US Only session.

5. Presentation format:

Authors prefer an oral presentation.

6. Areas of work addressed:

- a. Embedded Computing for Global Sensors and Information Dominance
- b. Advanced Digital Front-End Processors
- c. Automated Tools for Embedded System Development

Report Documentation Page

Form Approved
OMB No. 0704-0188

Public reporting burden for the collection of information is estimated to average 1 hour per response, including the time for reviewing instructions, searching existing data sources, gathering and maintaining the data needed, and completing and reviewing the collection of information. Send comments regarding this burden estimate or any other aspect of this collection of information, including suggestions for reducing this burden, to Washington Headquarters Services, Directorate for Information Operations and Reports, 1215 Jefferson Davis Highway, Suite 1204, Arlington VA 22202-4302. Respondents should be aware that notwithstanding any other provision of law, no person shall be subject to a penalty for failing to comply with a collection of information if it does not display a currently valid OMB control number.

1. REPORT DATE 23 SEP 2003		2. REPORT TYPE N/A		3. DATES COVERED -	
4. TITLE AND SUBTITLE Hybrid Optical/Digital Processor for Radar Imaging				5a. CONTRACT NUMBER	
				5b. GRANT NUMBER	
				5c. PROGRAM ELEMENT NUMBER	
6. AUTHOR(S)				5d. PROJECT NUMBER	
				5e. TASK NUMBER	
				5f. WORK UNIT NUMBER	
7. PERFORMING ORGANIZATION NAME(S) AND ADDRESS(ES) Essex Corporation 9150 Guilford Road Columbia, MD 21046; Annapolis Micro Systems, Inc. 190 Admiral Cochrane Dr. Suite 130 Annapolis, MD 21401				8. PERFORMING ORGANIZATION REPORT NUMBER	
9. SPONSORING/MONITORING AGENCY NAME(S) AND ADDRESS(ES)				10. SPONSOR/MONITOR'S ACRONYM(S)	
				11. SPONSOR/MONITOR'S REPORT NUMBER(S)	
12. DISTRIBUTION/AVAILABILITY STATEMENT Approved for public release, distribution unlimited					
13. SUPPLEMENTARY NOTES See also ADM001694, HPEC-6-Vol 1 ESC-TR-2003-081; High Performance Embedded Computing (HPEC) Workshop(7th). , The original document contains color images.					
14. ABSTRACT					
15. SUBJECT TERMS					
16. SECURITY CLASSIFICATION OF:			17. LIMITATION OF ABSTRACT	18. NUMBER OF PAGES	19a. NAME OF RESPONSIBLE PERSON
a. REPORT unclassified	b. ABSTRACT unclassified	c. THIS PAGE unclassified			

7. Abstract

Essex is developing a prototype hybrid optical/digital processor for radar image formation using wideband arbitrary waveforms. The processor is called the Advanced Optical Processor (AOP) and is a hybrid acousto-optic/digital processor that generates high dynamic range, range-Doppler images from wideband radar returns. This work is being funded by the Missile Defense Agency's office of Manufacturability and Producibility (MDA/MP) and will be tested at the MIT/LL Lexington Development Facility. The processor supports high resolution processing necessary for target discrimination and kill assessment by enabling the use of true arbitrary, wideband waveforms. The selected architecture combines the advantages of both embedded optical signal processing for the front-end receiver and embedded high-speed digital signal processing for the real-time post processing. This combination provides the capacity to process signals with 1 GHz of instantaneous bandwidth in a real-time environment without the need for wideband analog-to-digital converters (ADCs). This is achieved in a compact lightweight package that combines both an optical coherent channelizer and a WILDSTARII™ FPGA VME board from Annapolis Micro Systems that performs the real-time post processing. The AOP2 architecture is shown below:

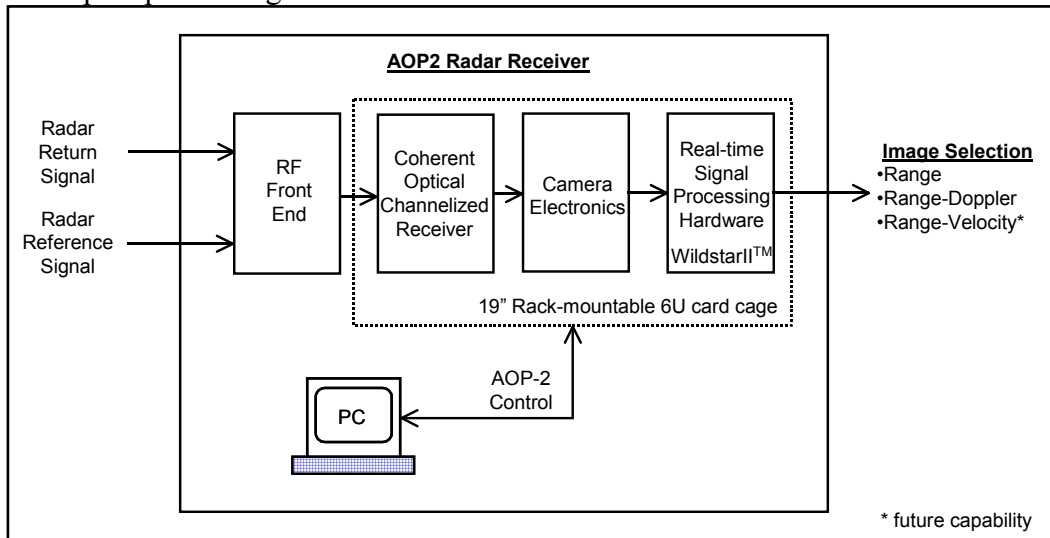

AOP2 Architecture

The AOP2 prototype hardware is shown below:

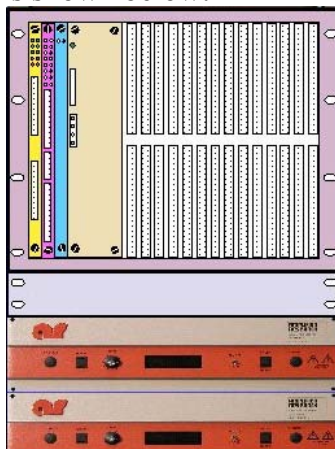

AOP2 Prototype Hardware

The production hardware can easily fit into a single 6U card cage, as shown below, without significant development costs.

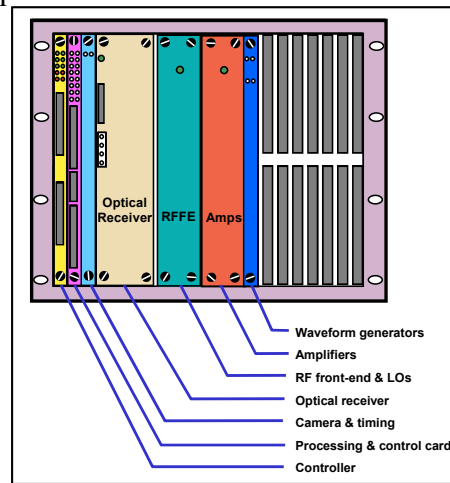

AOP Production Configuration

By removing complex software and custom digital hardware, the cost for this processor is significantly less than an “all-digital” solution, even in modest quantities. The cost effectiveness of this processor allows use at the sub-array level for desired operational flexibility and performance enhancements, such as beamforming and STAP.

The development of this processor has been accelerated with the use of the AMS CoreFire™ FPGA Application Builder. This tool has allowed the mapping of the post processing algorithms to the COTS AMS FPGA hardware with minimal effort. Selected AOP2 algorithms were running as a demonstration in the WildstarII™ for the AOP2 critical design review with just a few weeks of effort. CoreFire™ also provided a hardware-in-the-loop debugger that allowed us to insert test data into the designs in the FPGAs and then review the test vectors from the host as they ran through each part of the algorithm. The AMS hardware configuration is a 6U form factor with 3 Xilinx Virtex II™ 6000 series FPGAs. This WILDSTARII board also has two I/O daughter card positions providing in excess of 4 GB/s I/O bandwidth. The DSP algorithms running in this hardware include:

1. data formatting algorithms
2. calibration algorithms
3. range-compression algorithm
4. Doppler compression algorithm
5. data storage formatting
6. display formatting
7. system timing and control functions

The chosen hardware can perform these algorithms in real-time and is flexible such that changes in the algorithms are easily accommodated. There is no operating system required so integration issues with a single board VME control computer are minimal.

Presented in this paper will be the architecture description and integration of the optical and FPGA technologies, along with updated test results.



ESSEX



Hybrid Optical/Digital Processor for Radar Imaging

23 September 2003

**Keith Frampton
Essex Corporation
9150 Guilford Road
Columbia, MD 21046
301-953-7875
Frampton@essexcorp.com**

**Pat Stover
Annapolis Micro Systems
190 Admiral Cochrane Dr. Suite 130
Annapolis, MD 21401
410-841-2514
Patrick.stover@annapmicro.com**

- **Problem:**
 - Projected BMD threat environment will have clutter and EMI
 - LFM waveforms have limitations with these threats
 - Desired advanced waveforms (chaotic, PRN*, ...) are very processing intensive

- **Solution:**
 - The advanced optical processor (AOP) generates range-Doppler images from advanced arbitrary waveforms
 - AOP architecture incorporates:
 - Embedded optical signal processing
 - Embedded digital signal processing in FPGAs

Program Objectives



- Modernize the architecture, scaling to:
 - 1 GHz
 - Real-time operation
 - Full complex, single pass
 - Store images in real-time to disk
- Compact rack stackable configuration

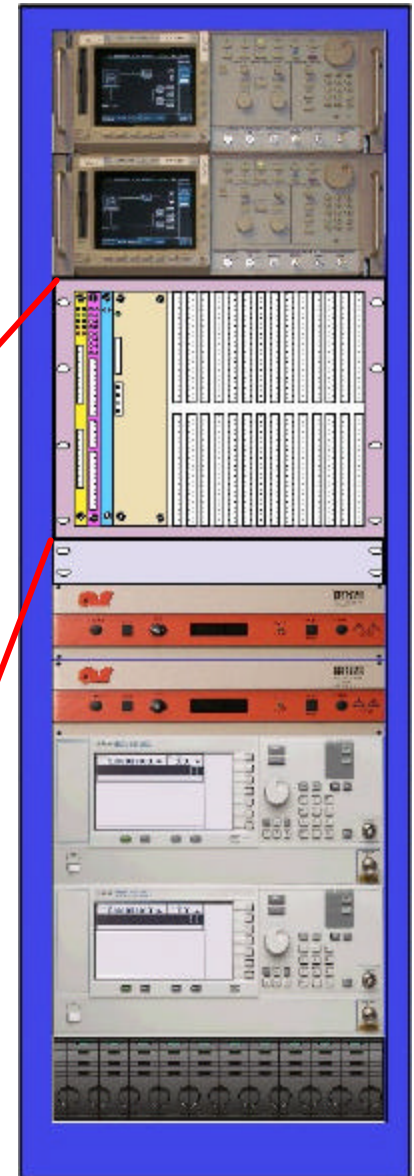
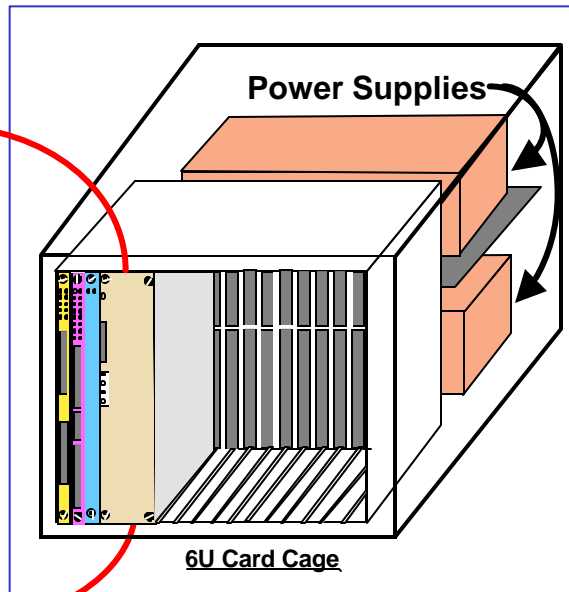
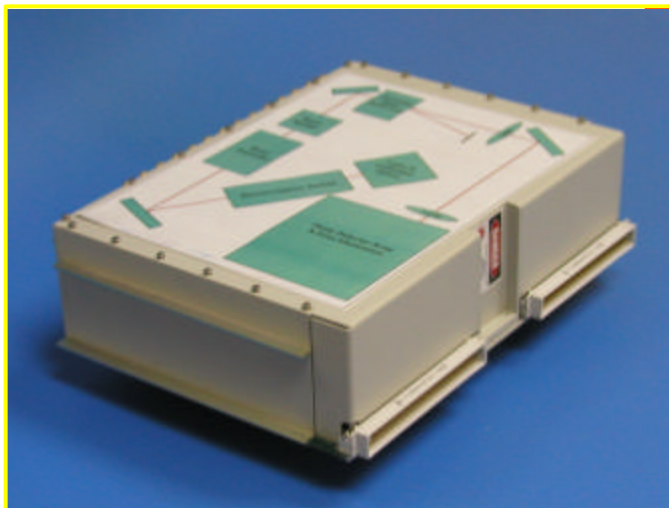

AOP 2 Performance Characteristics



Pulse Width	10 ? sec to 50 msec
Pulse Repetition Interval (PRI)	100 usec minimum
Pulse Repetition Frequency (PRF)	10 kHz maximum
Center Frequency	Tunable 5 GHz to 7 GHz (TBR)
Bandwidth (-3dB)	1 GHz
Stable Reference Frequency	10 MHz
Post-Compression Dynamic Range (peak to RMS noise)	66 dB
Spur Free Dynamic Range	85 dB for 128 coherently integrated pulses
Range Resolution	0.15 meters
SNR Loss vs. Range center	6 dB maximum @ +/- 76.7 meters relative to image center
Range Bins	1024 bins (+/- 512 about image center)
Range Extent	153 meters (+/-76.7 m about image center)
Range Sidelobes (Hamming weighting)	-34 dB
Frequency Response	3 dB uncorrected; 1 dB corrected
RCS Repeatability	+/- 0.1 dB
Phase Deviation from Linear in CPS	+/- 5 degrees

Algorithm Functionality is Similar

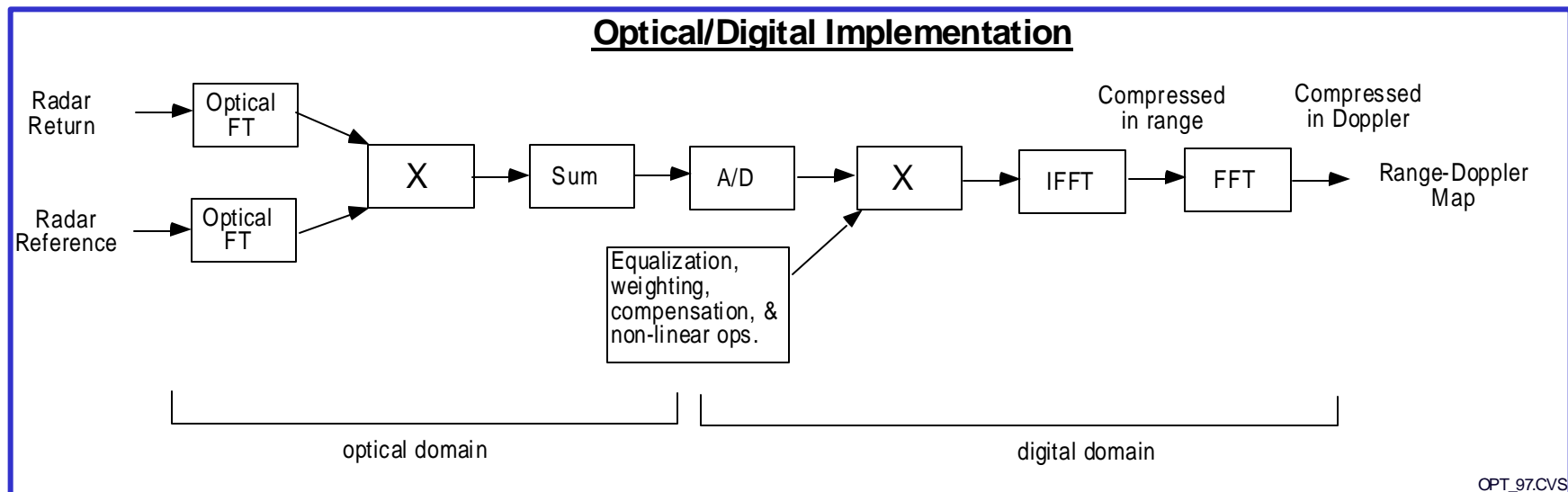
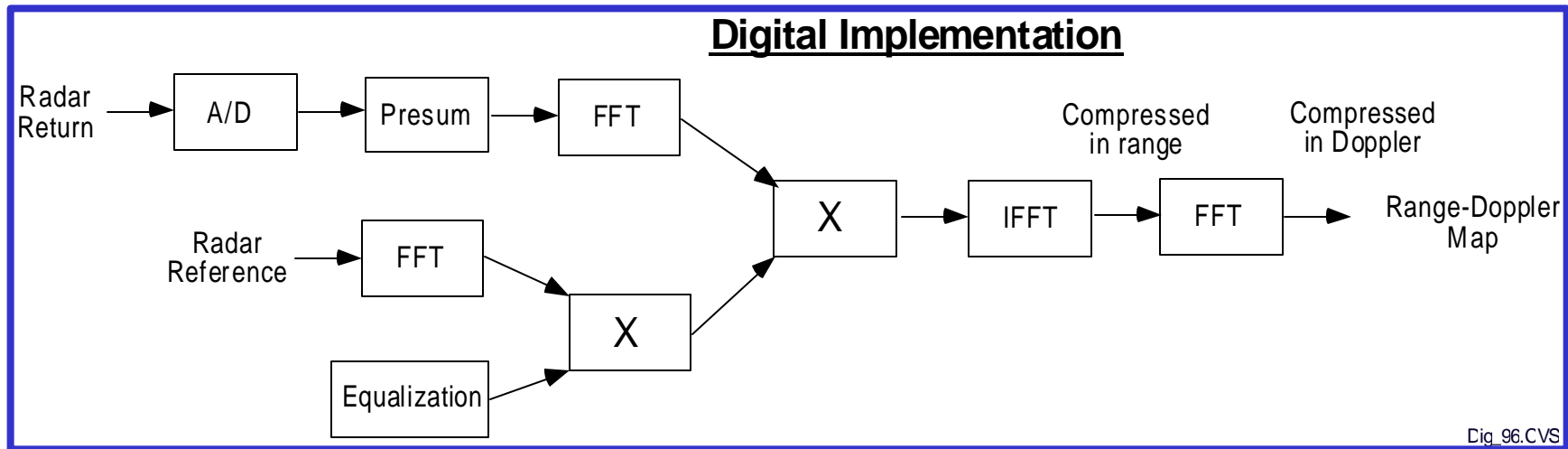

Process Flow



Cross power spectra vs. time

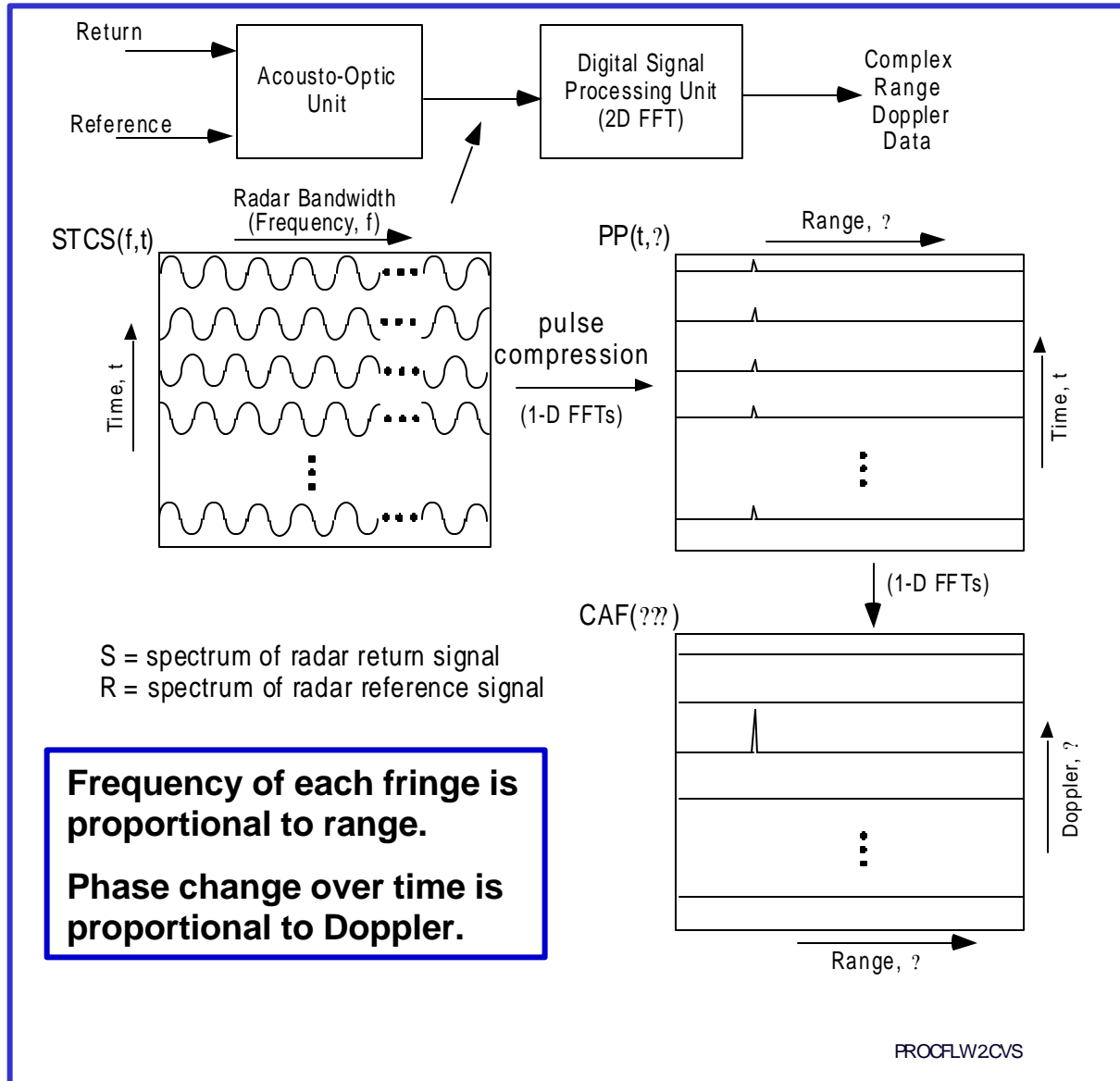

Correlator compresses pulse in range

FFT compresses pulses in Doppler

AOP2 Functional Configuration

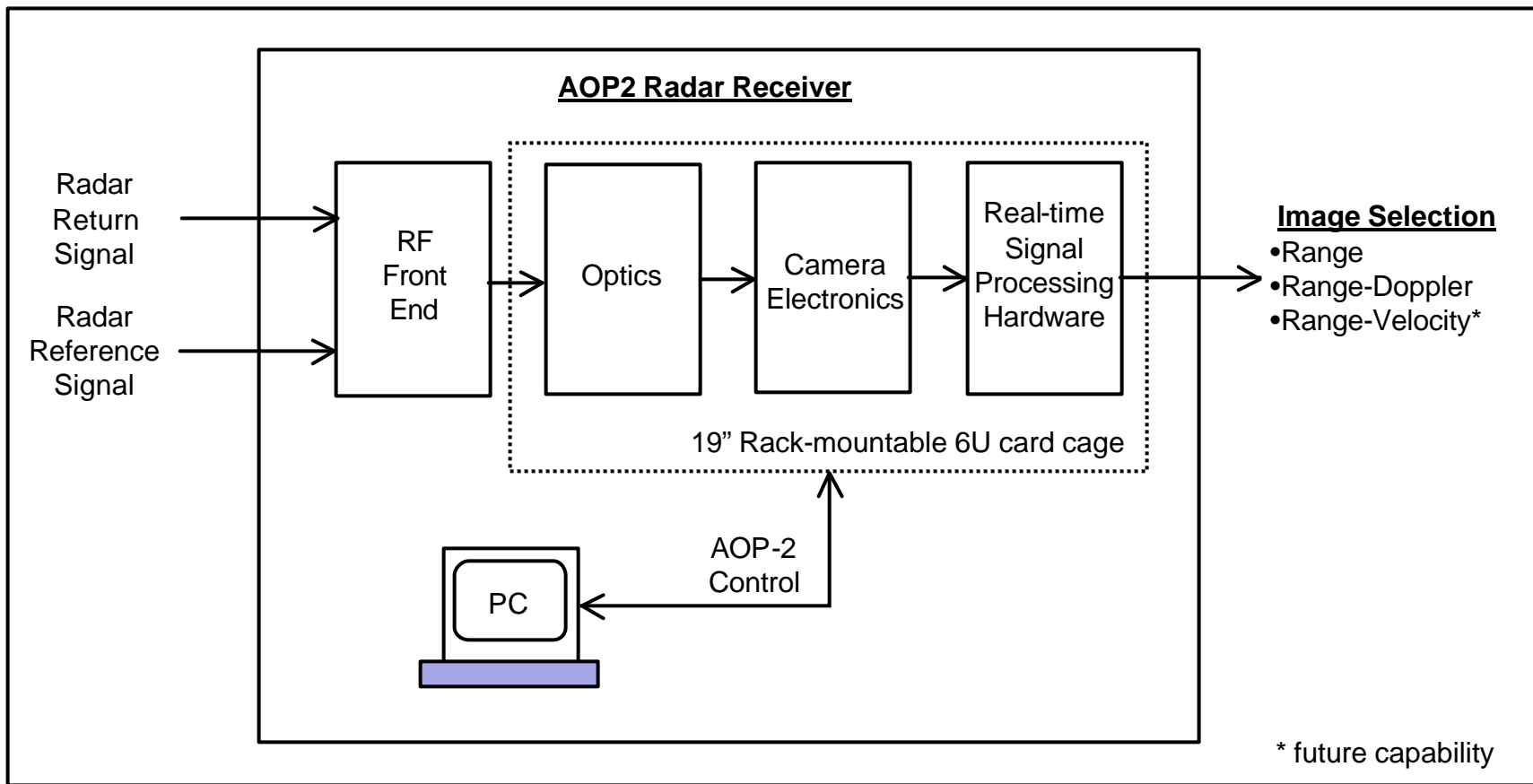

AOP 2 Top Level System Diagram

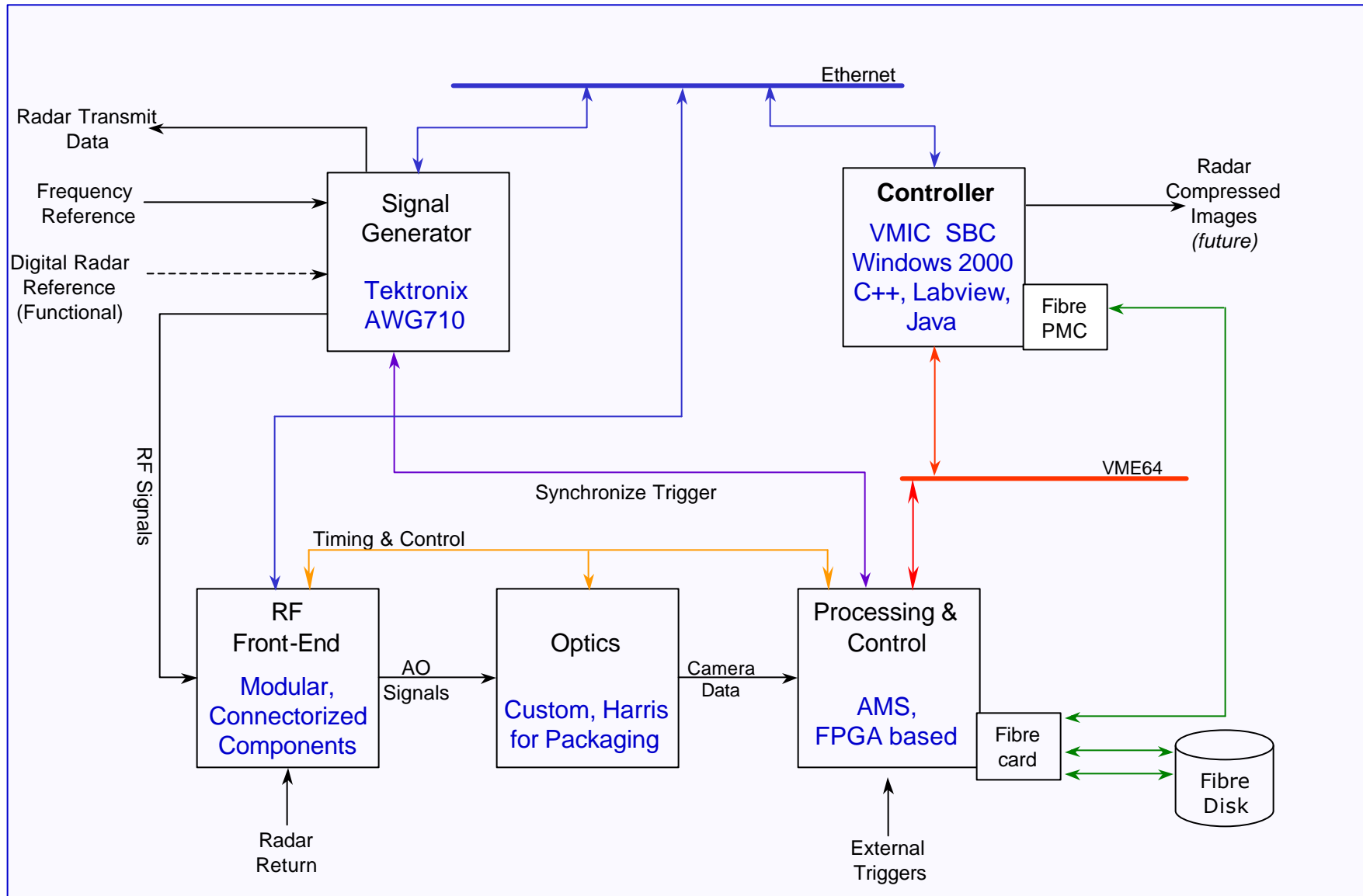

Radar Configuration with AOP2

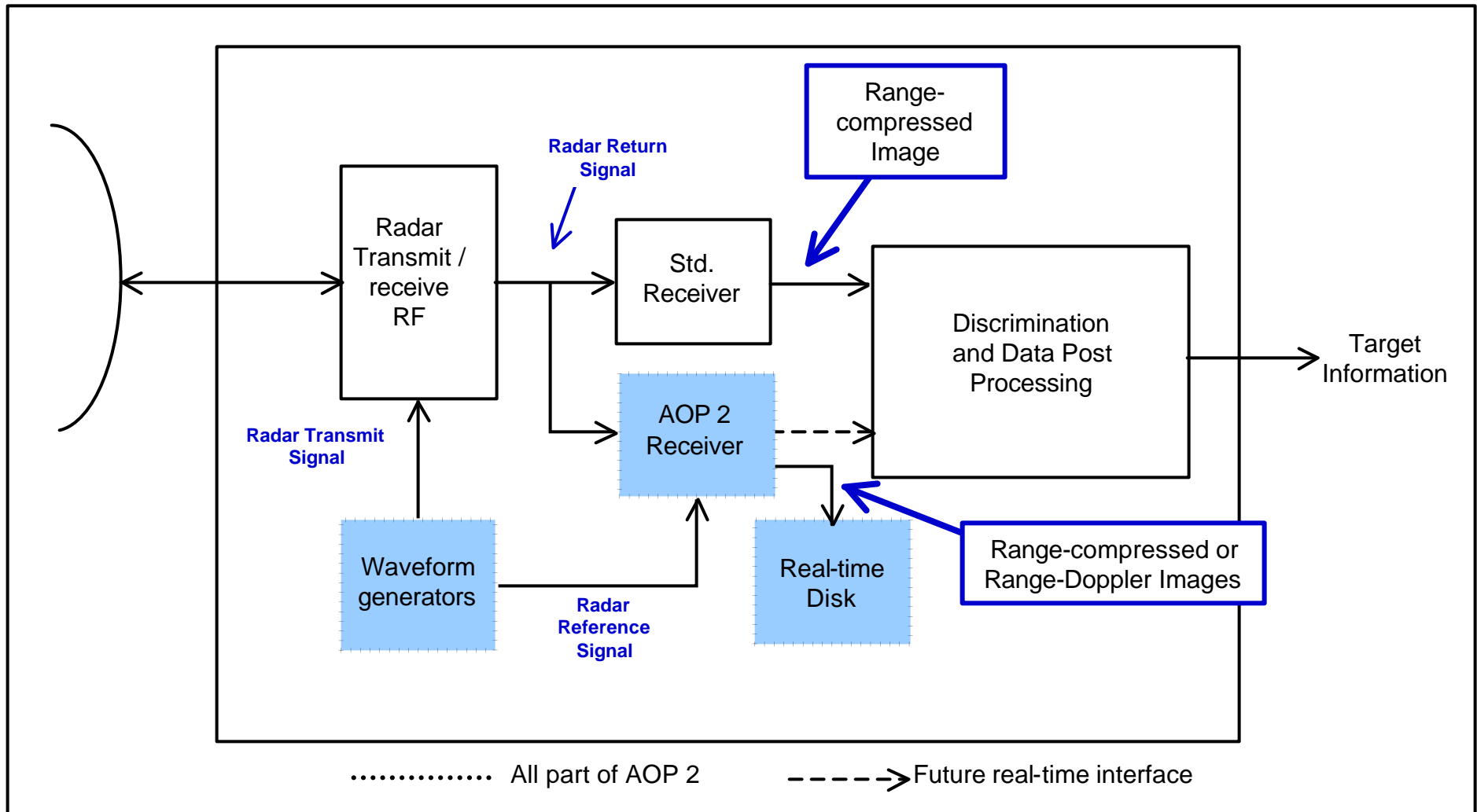

AOP2 Configuration

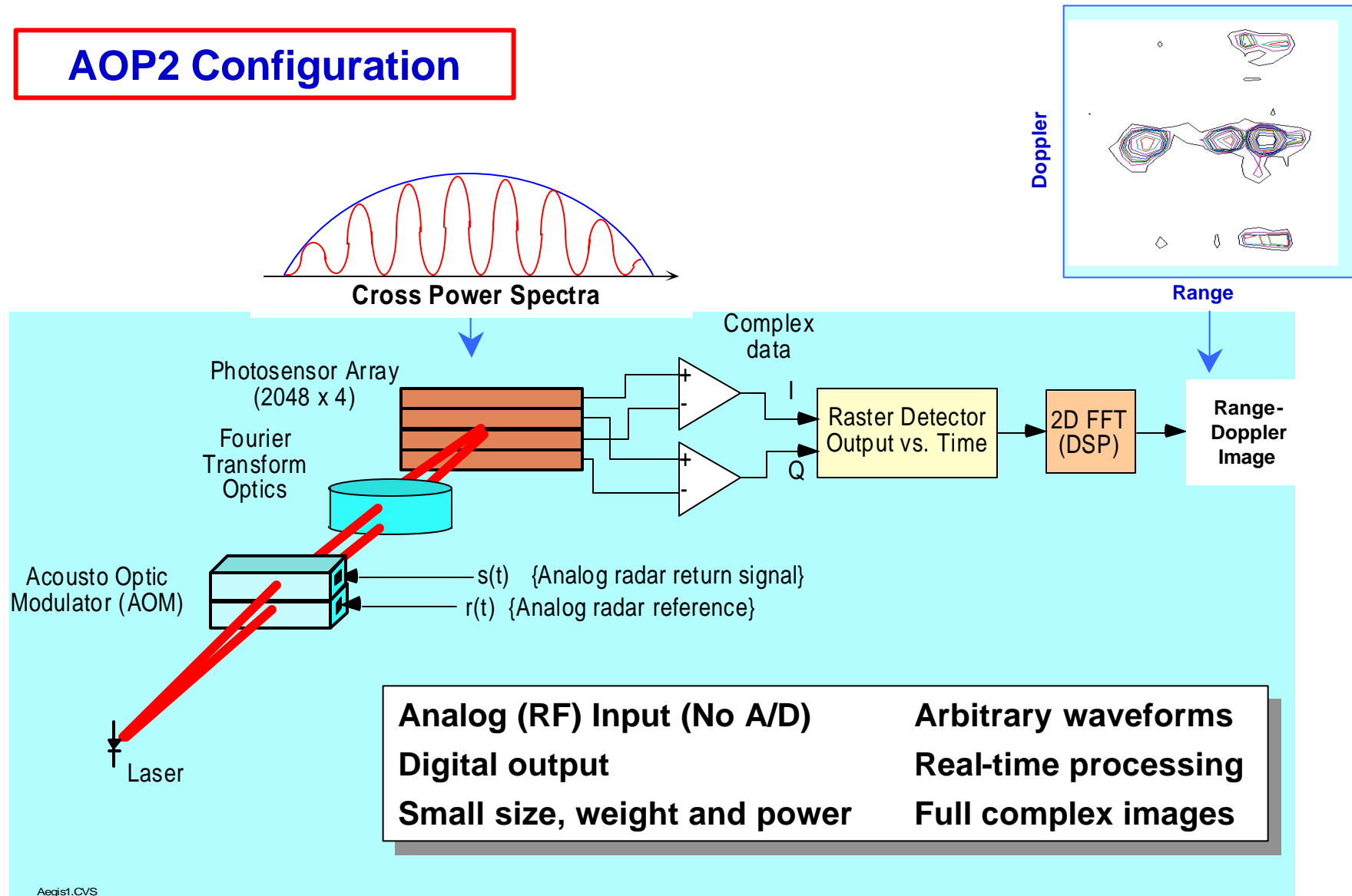

- | | |
|-------------------------------------|-----------------------------|
| Analog (RF) Input (No A/D) | Arbitrary waveforms |
| Digital output | Real-time processing |
| Small size, weight and power | Full complex images |

Aegis1.CVS

Optics Module Mated With Camera Module

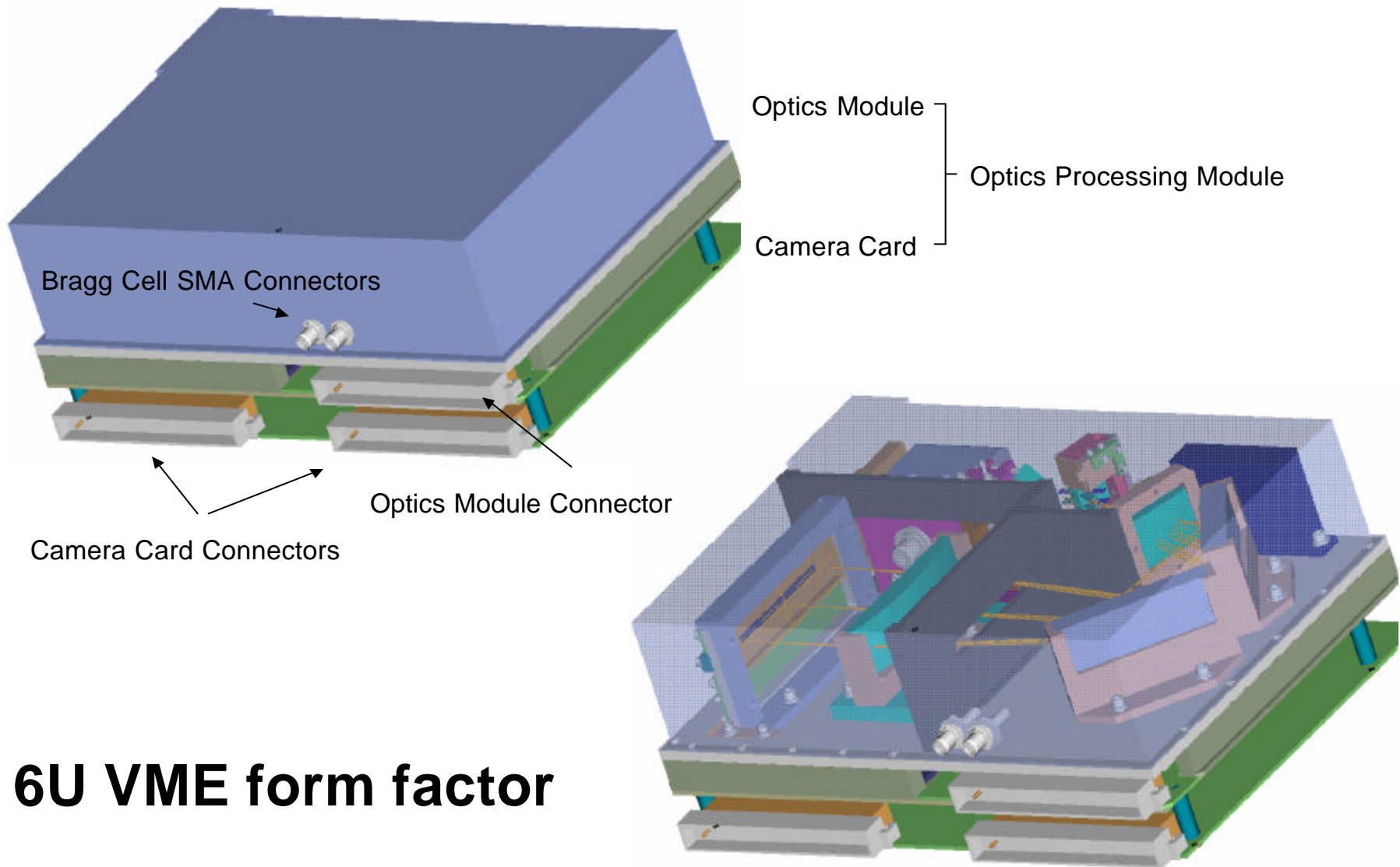

6U VME form factor

AOP2 Optics Module

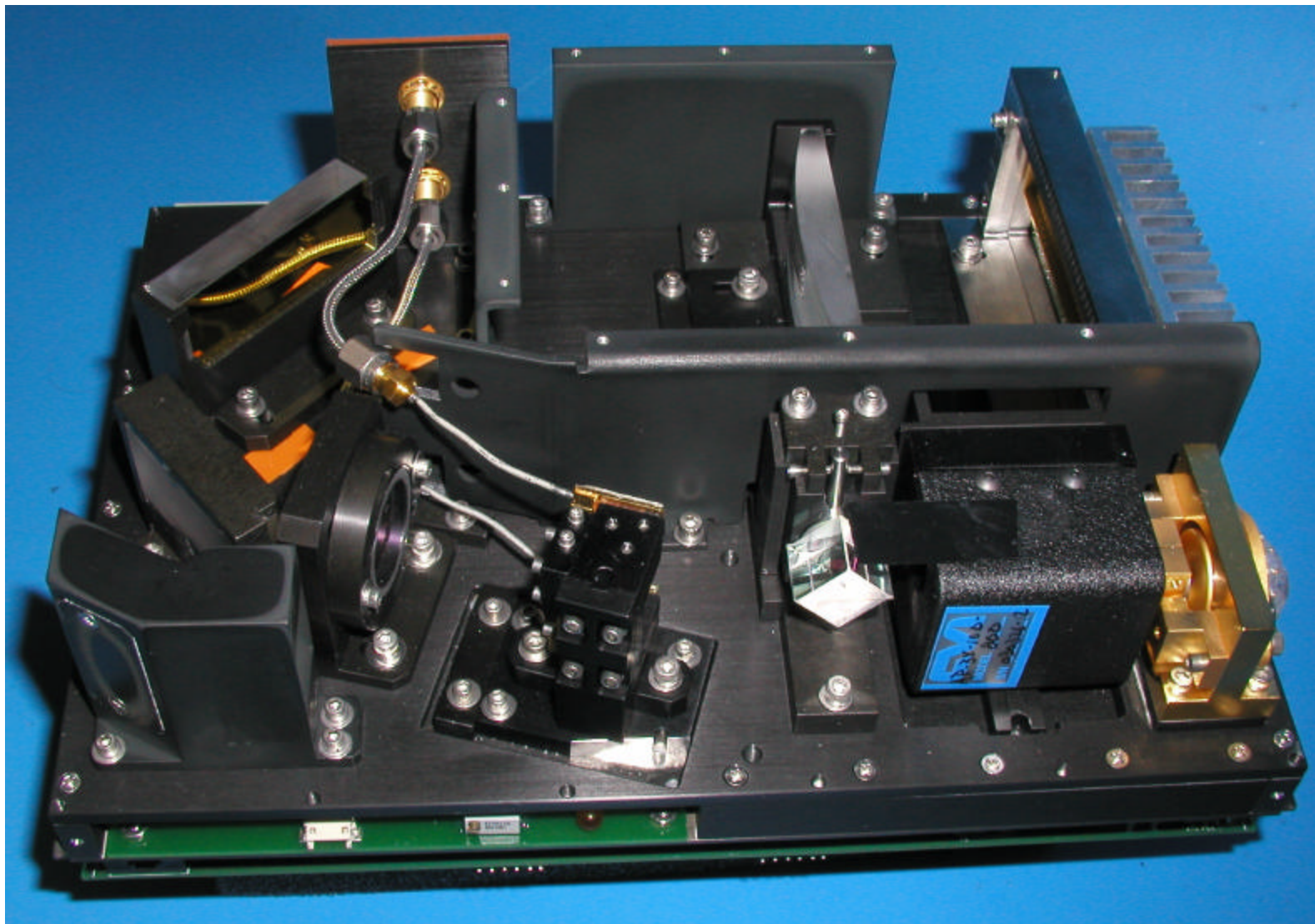

HEPC 2003 September 23, 2003

- **Calibrations and corrections are required at various points in the processing chain**
 - **Correct radar and processor response**
 - **Obtain optimum performance**

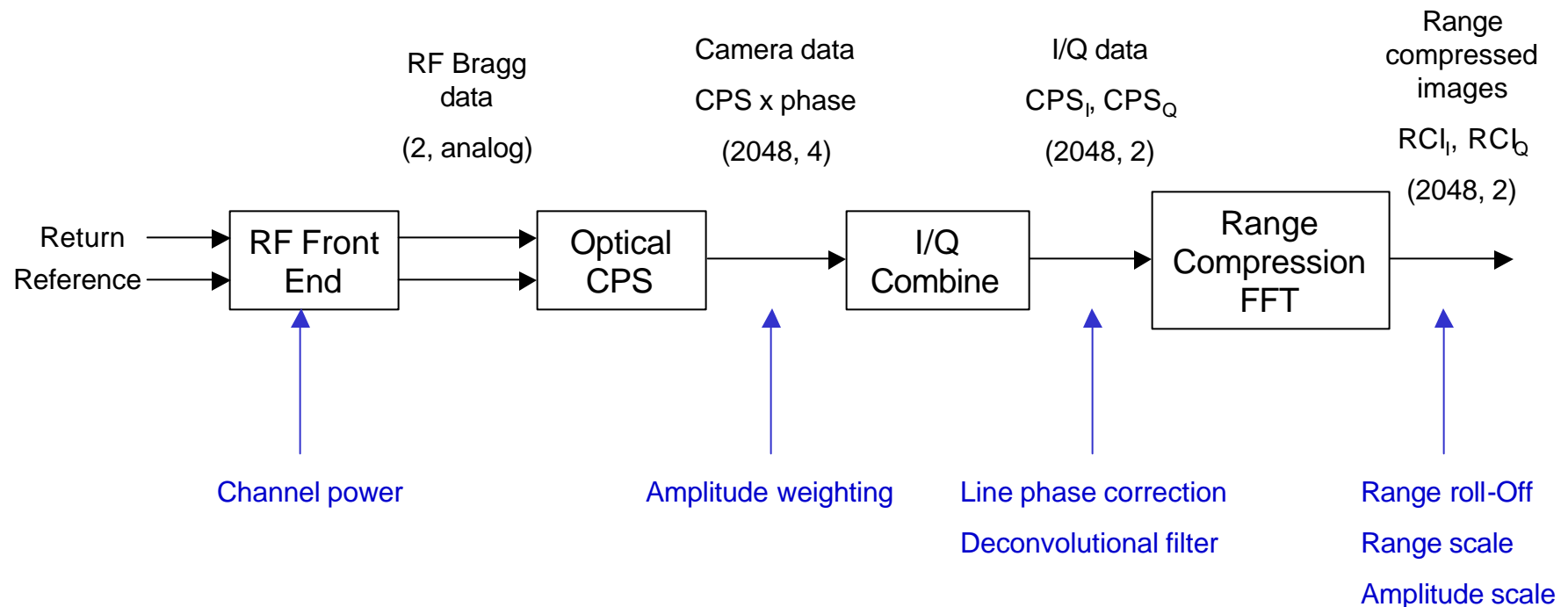

AOP2 Hardware Configuration*



Waveform generators

- Reference
- Return

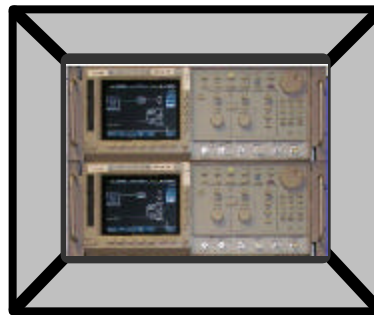

Programmable LOs for tunable RF front-end



Real-time file system



UPS

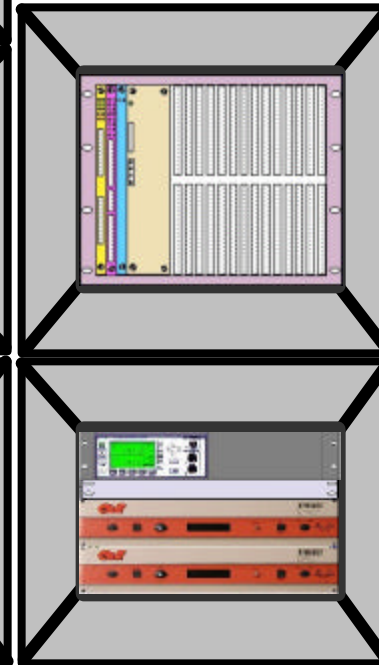

6U card cage

- Controller card
- Optical module
- Post processing & Timing card

Power Meter

RF module

Power amplifiers

AOP Production Conceptual Configuration



Size reduced from $\frac{1}{2}$ rack in AOP2 demonstration to $\frac{1}{2}$ single 6U chassis:

- AWGs reduced to single chip for PRN codes
- Synthesizers reduced to fixed LOs
- Amplifiers reduced to single card
- No output data storage, data sent to radar post processing in real time

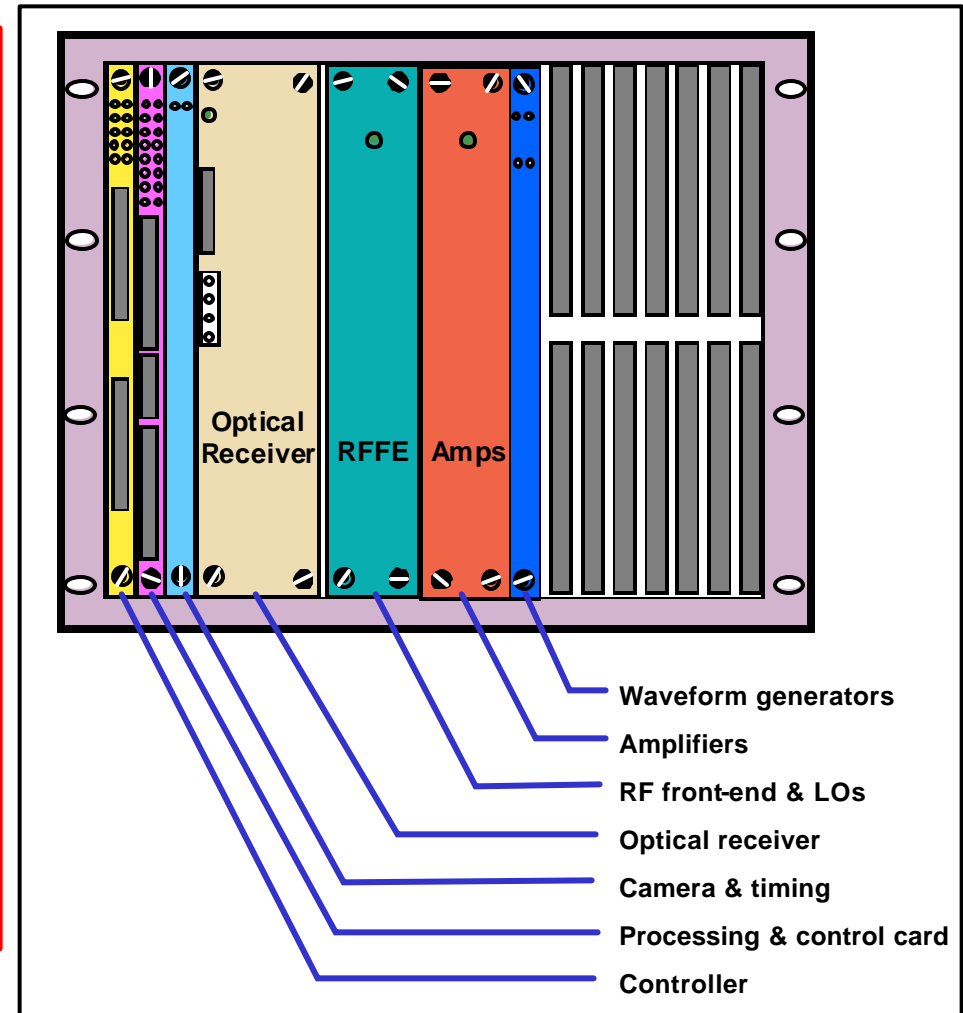

Post Processing & Control Subsystem (PCS) **ESSEX**

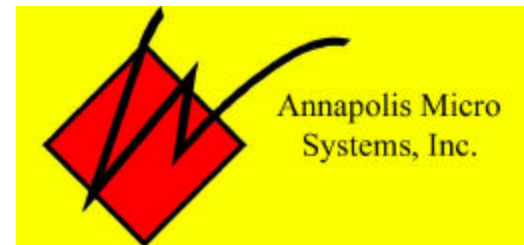
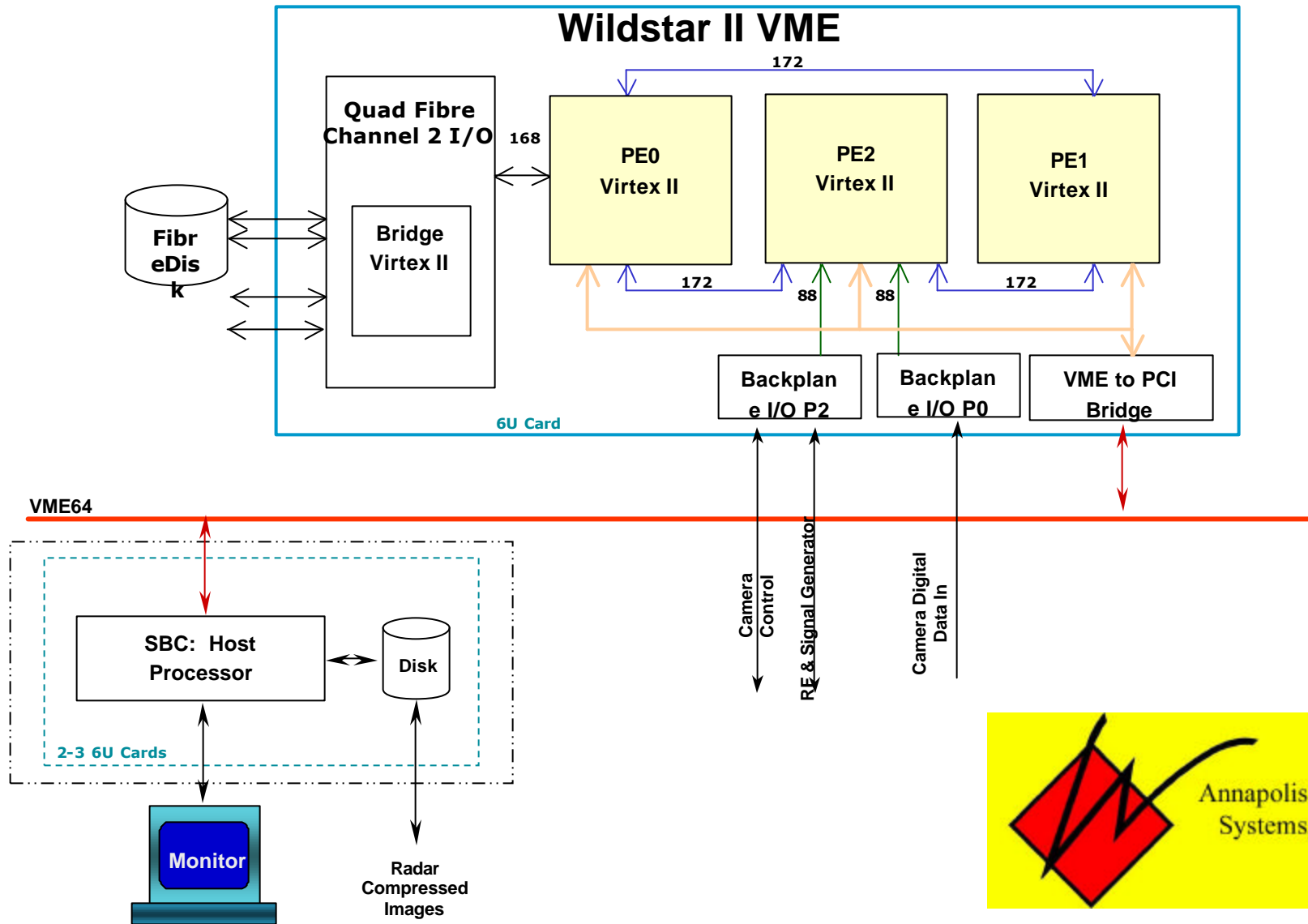

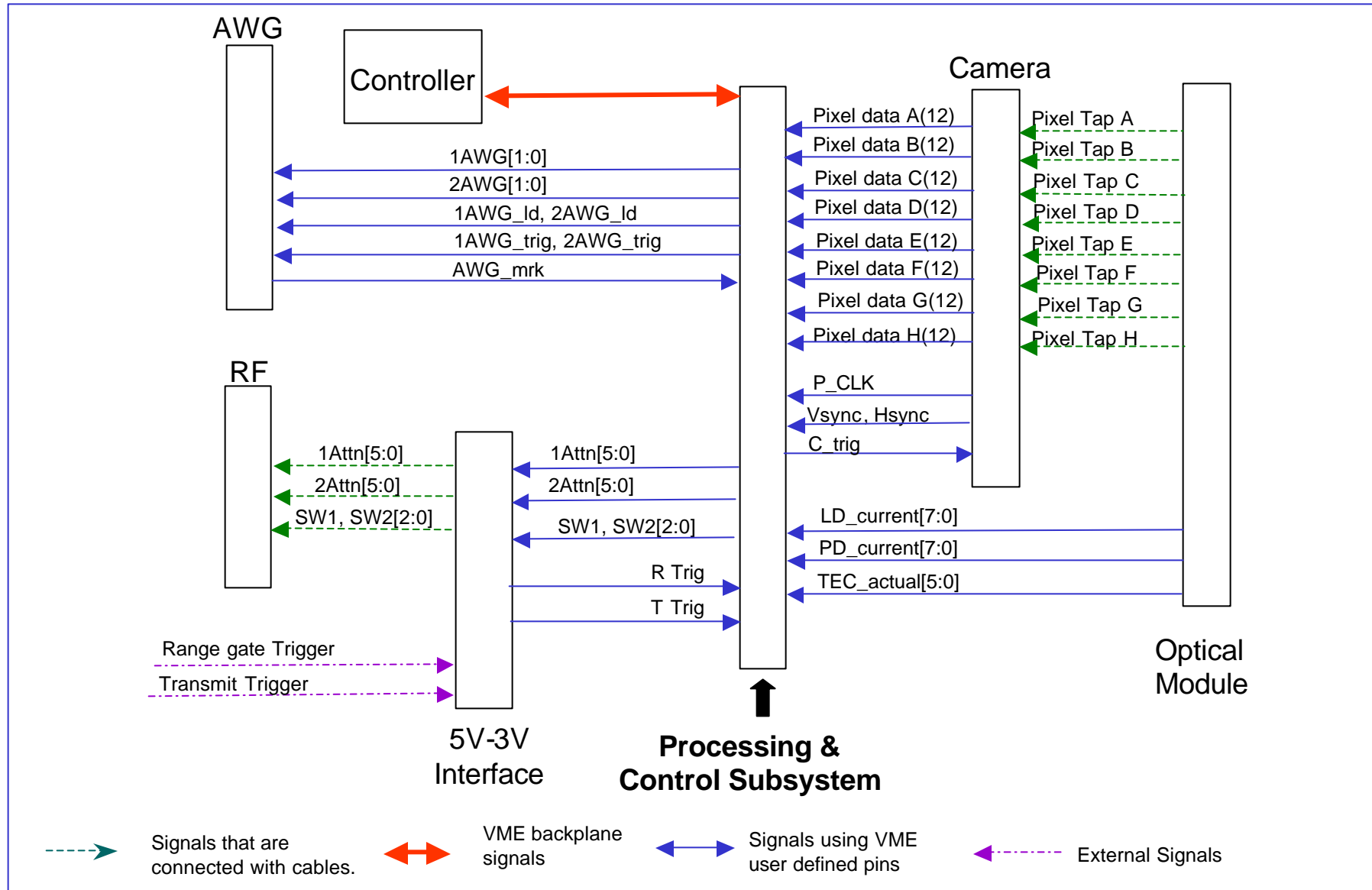

FPGA based reconfigurable computing board

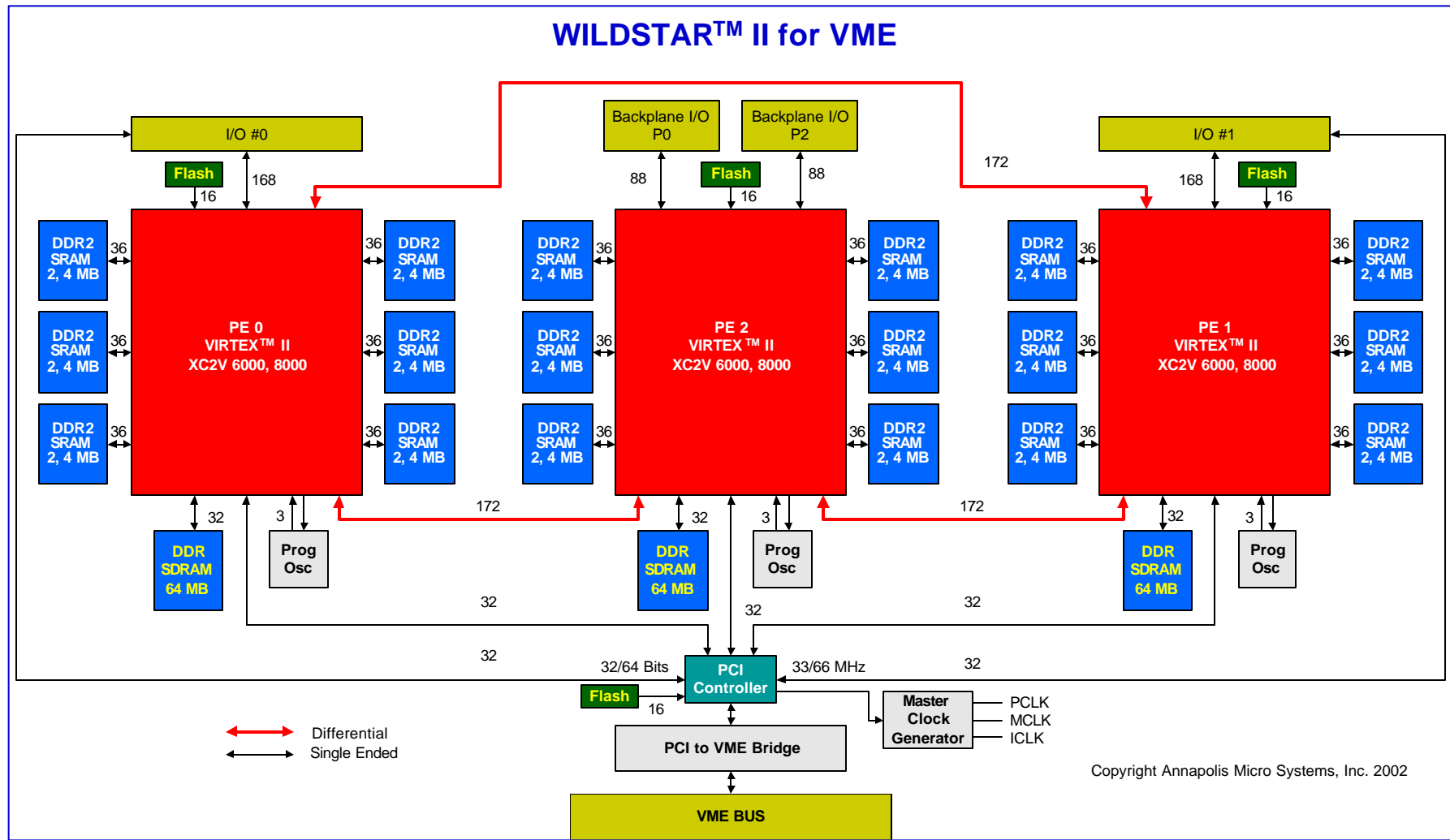

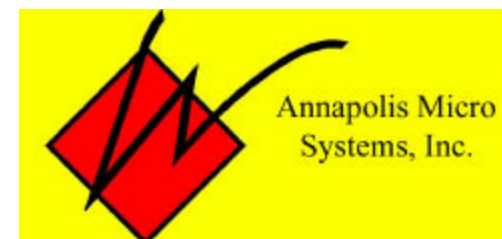
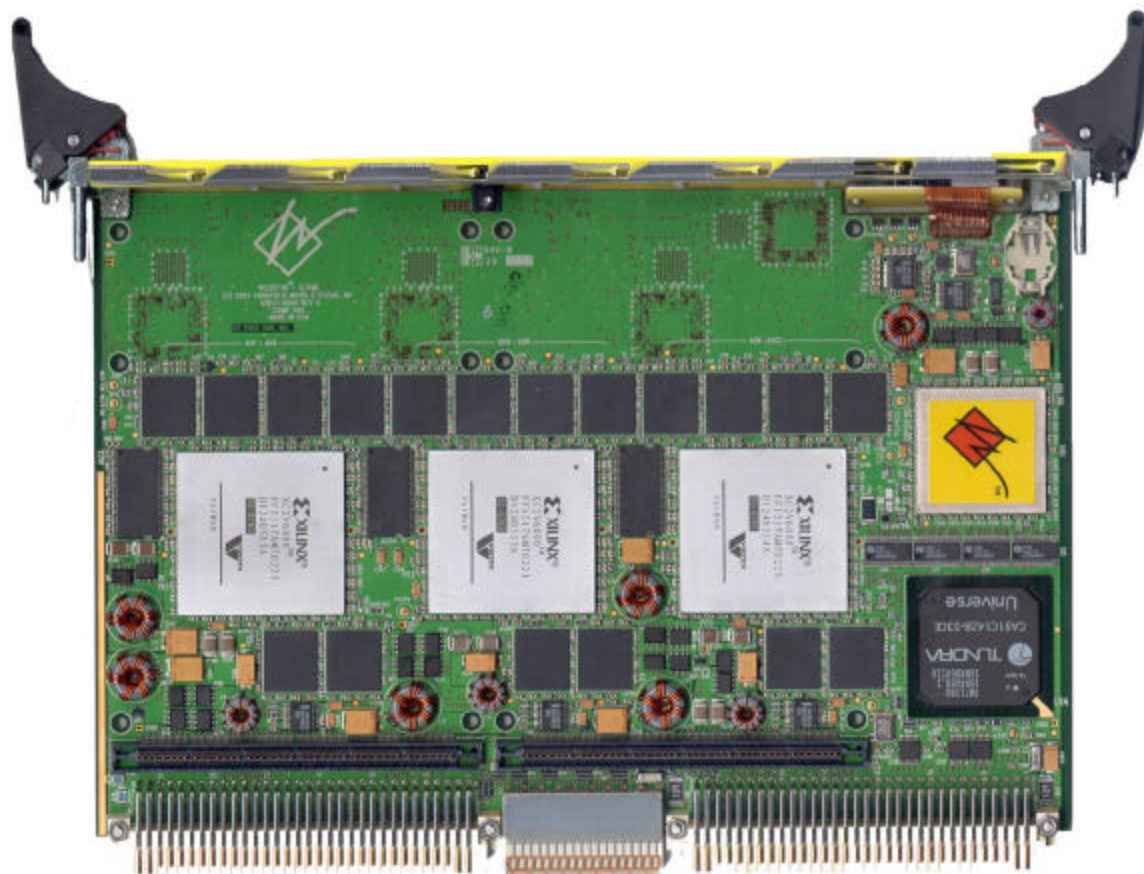

WILDSTAR™ II FPGA card

Fibre Channel 2 I/O Card daughter card

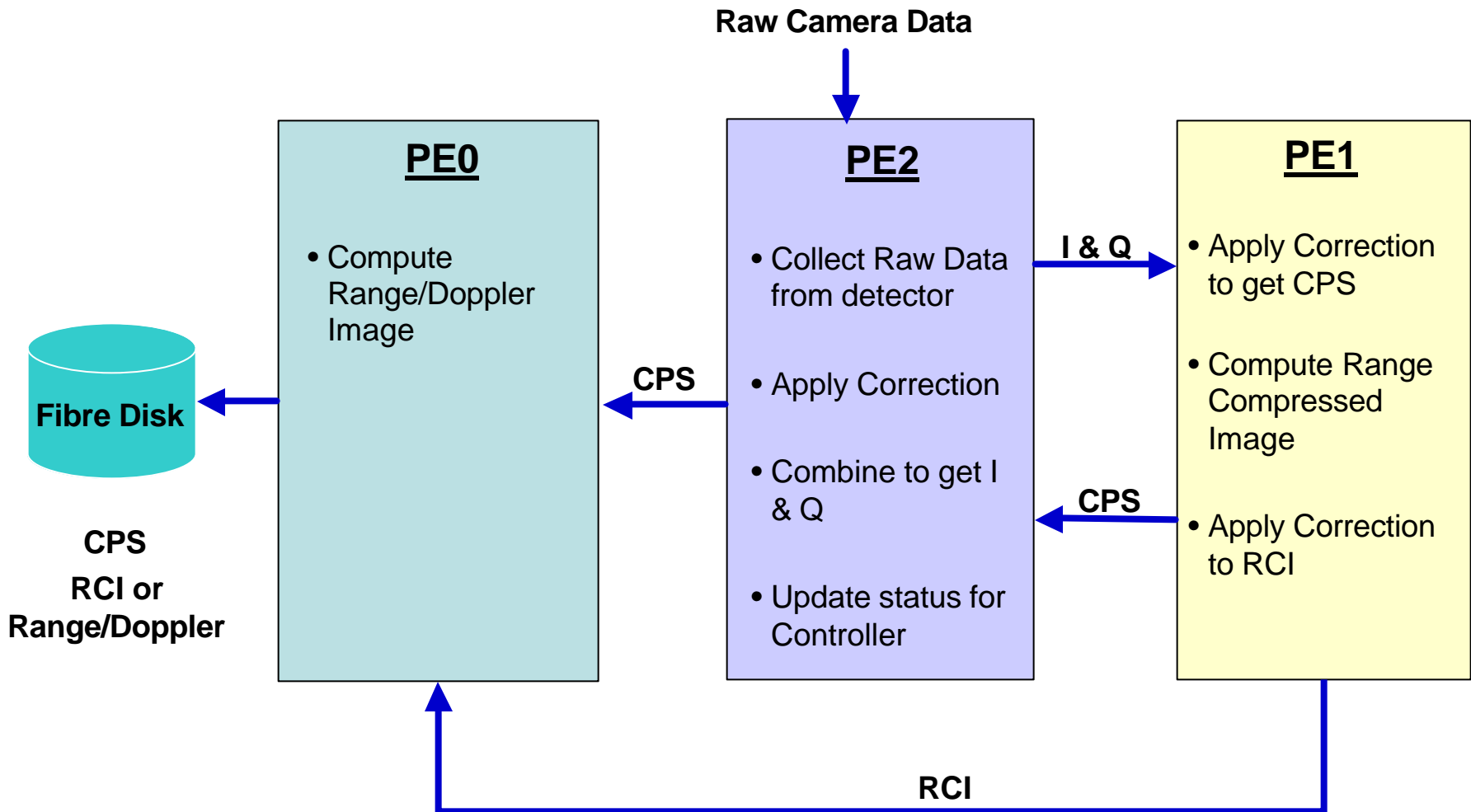

PE2 Data Processing

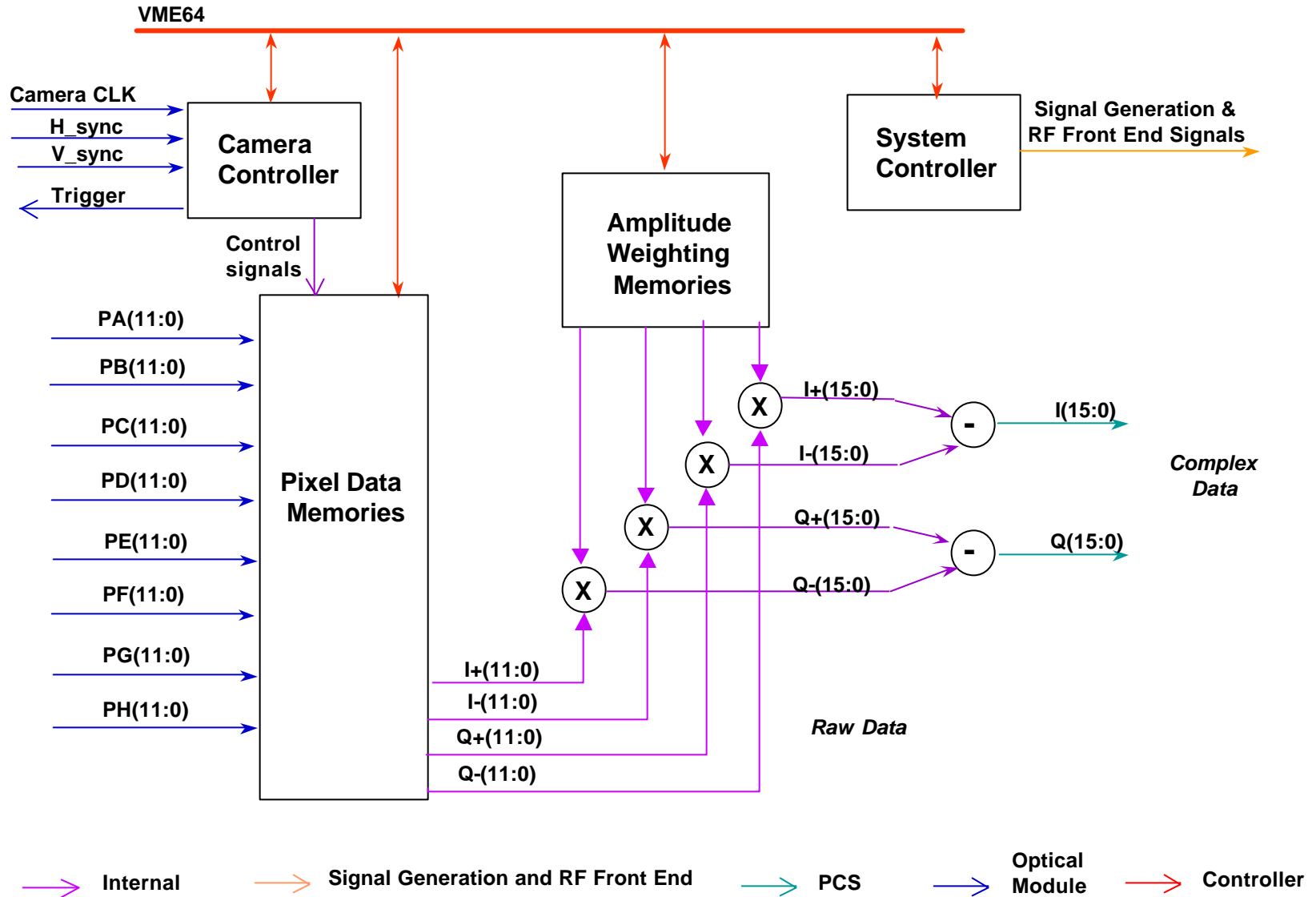

PE2 Allocated Memory Diagram

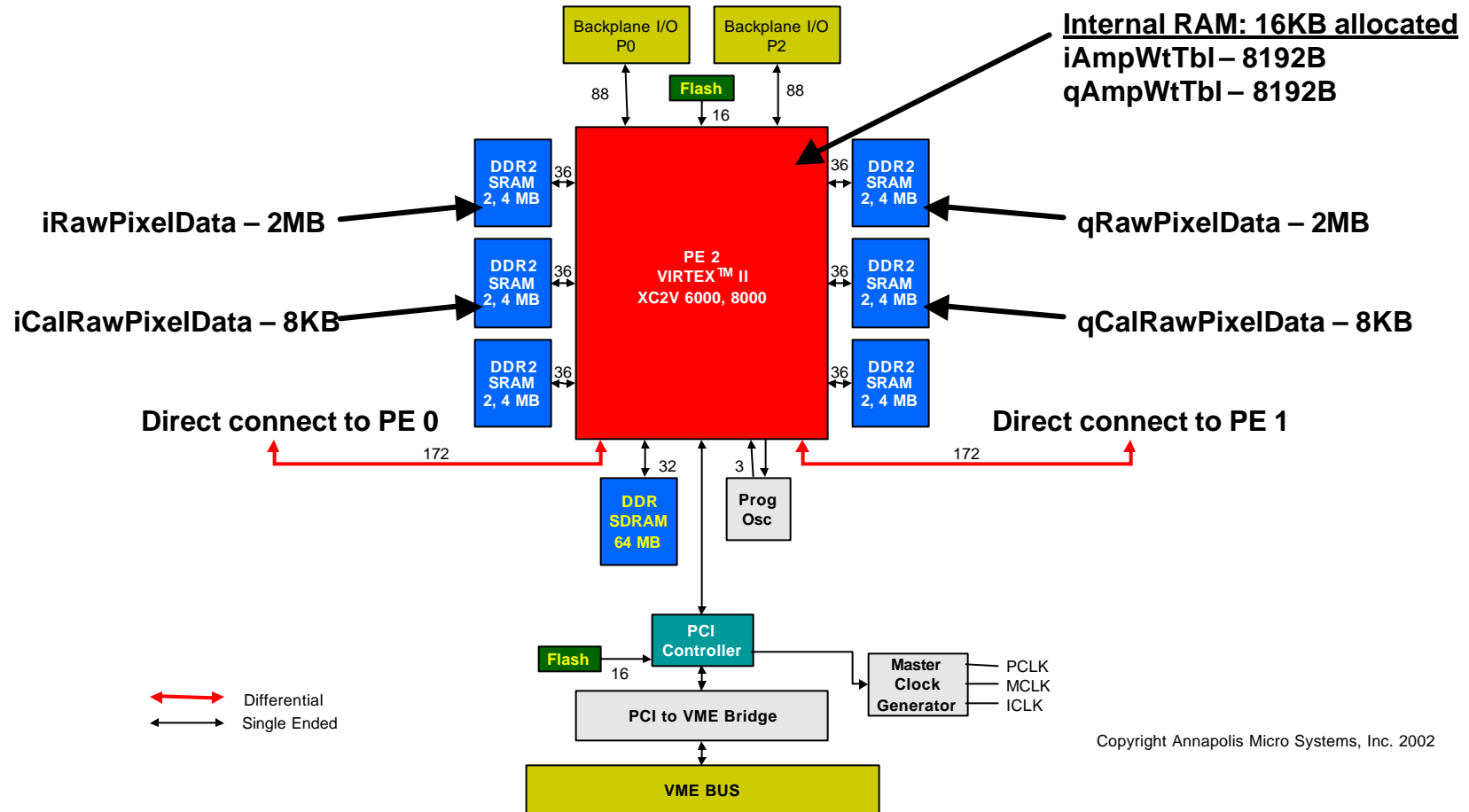

Copyright Annapolis Micro Systems, Inc. 2002

PE1 Functional Flow Diagram

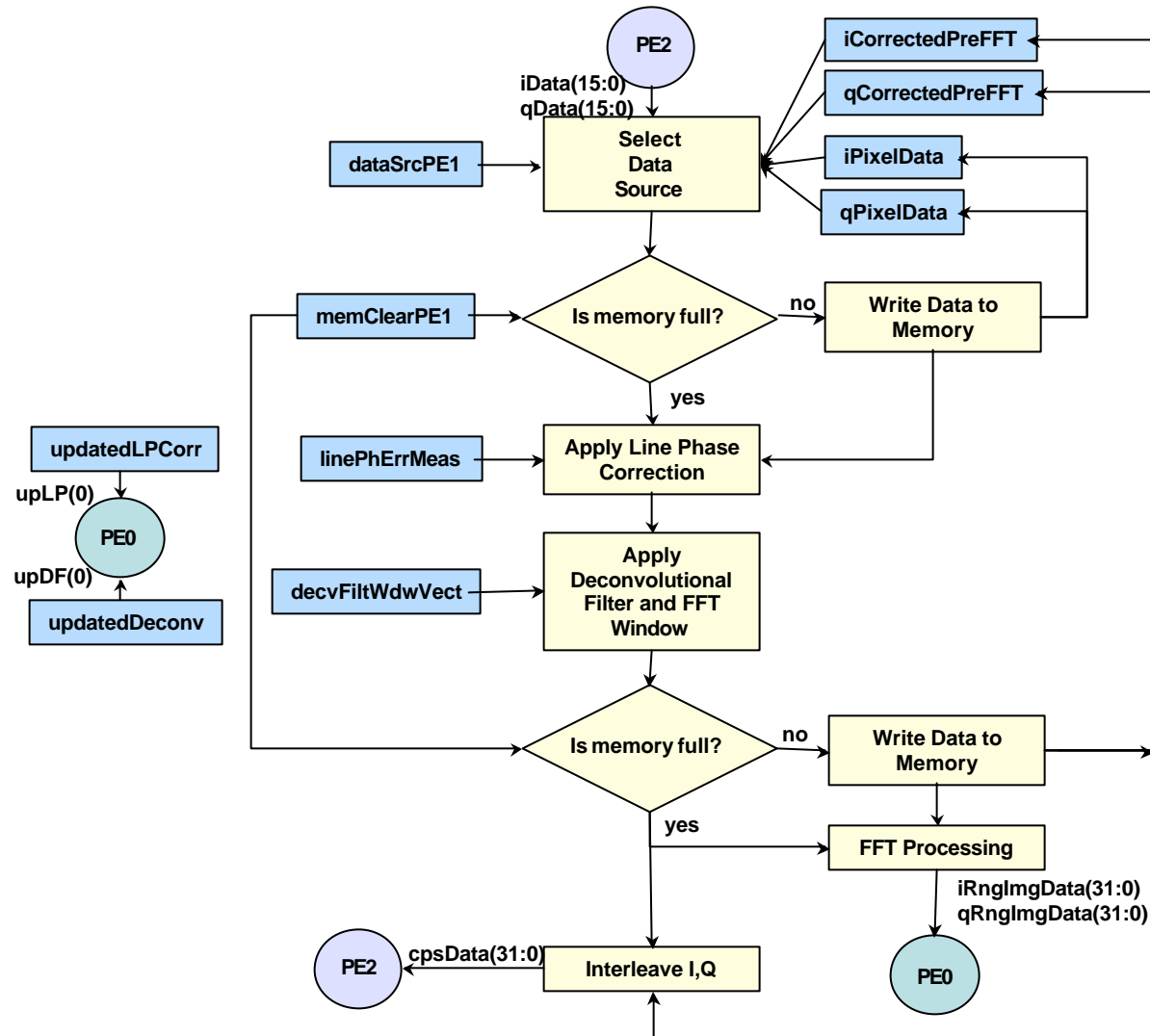

PE1 Allocated Memory Diagram

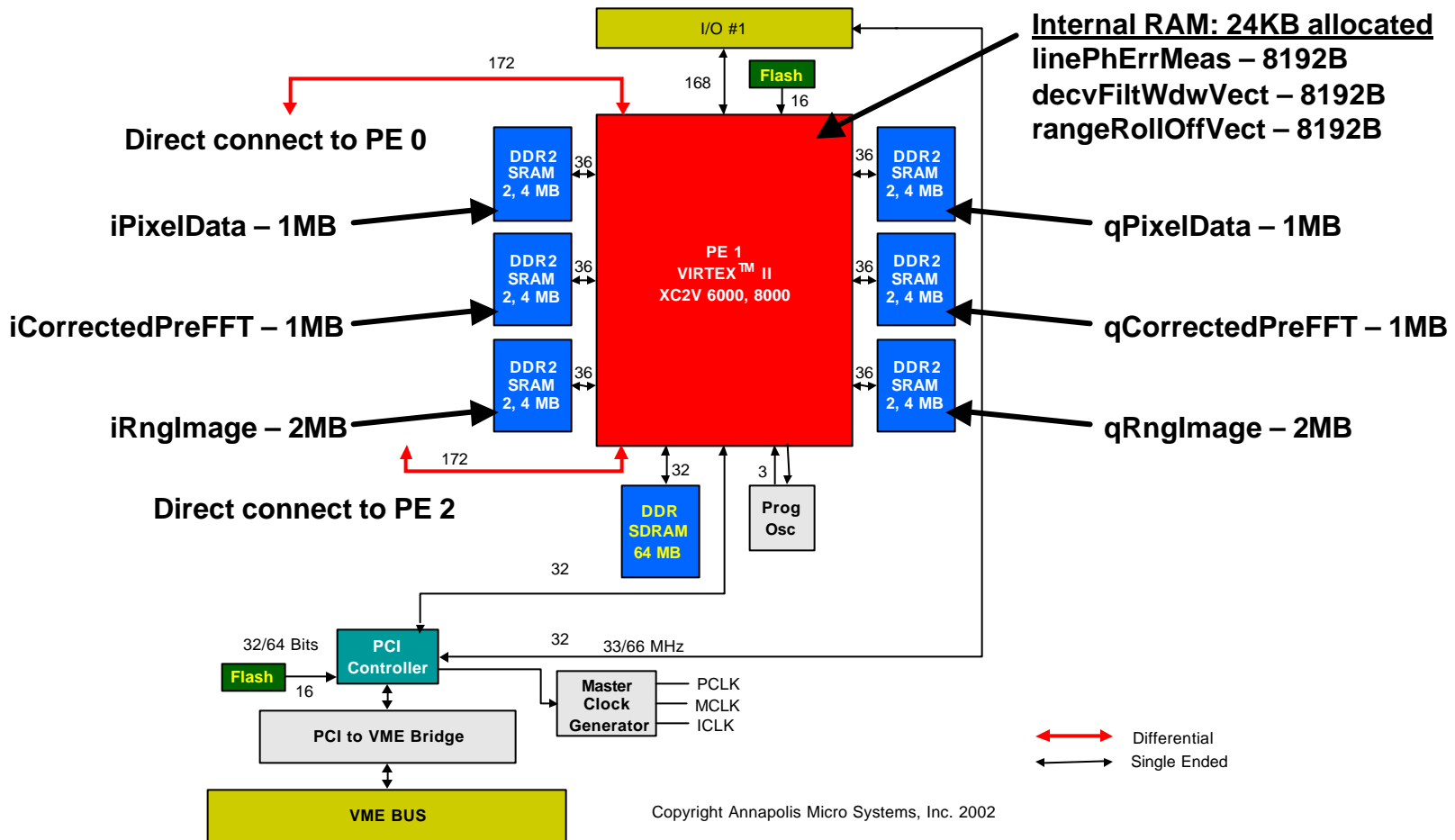

PE0 Functional Diagram

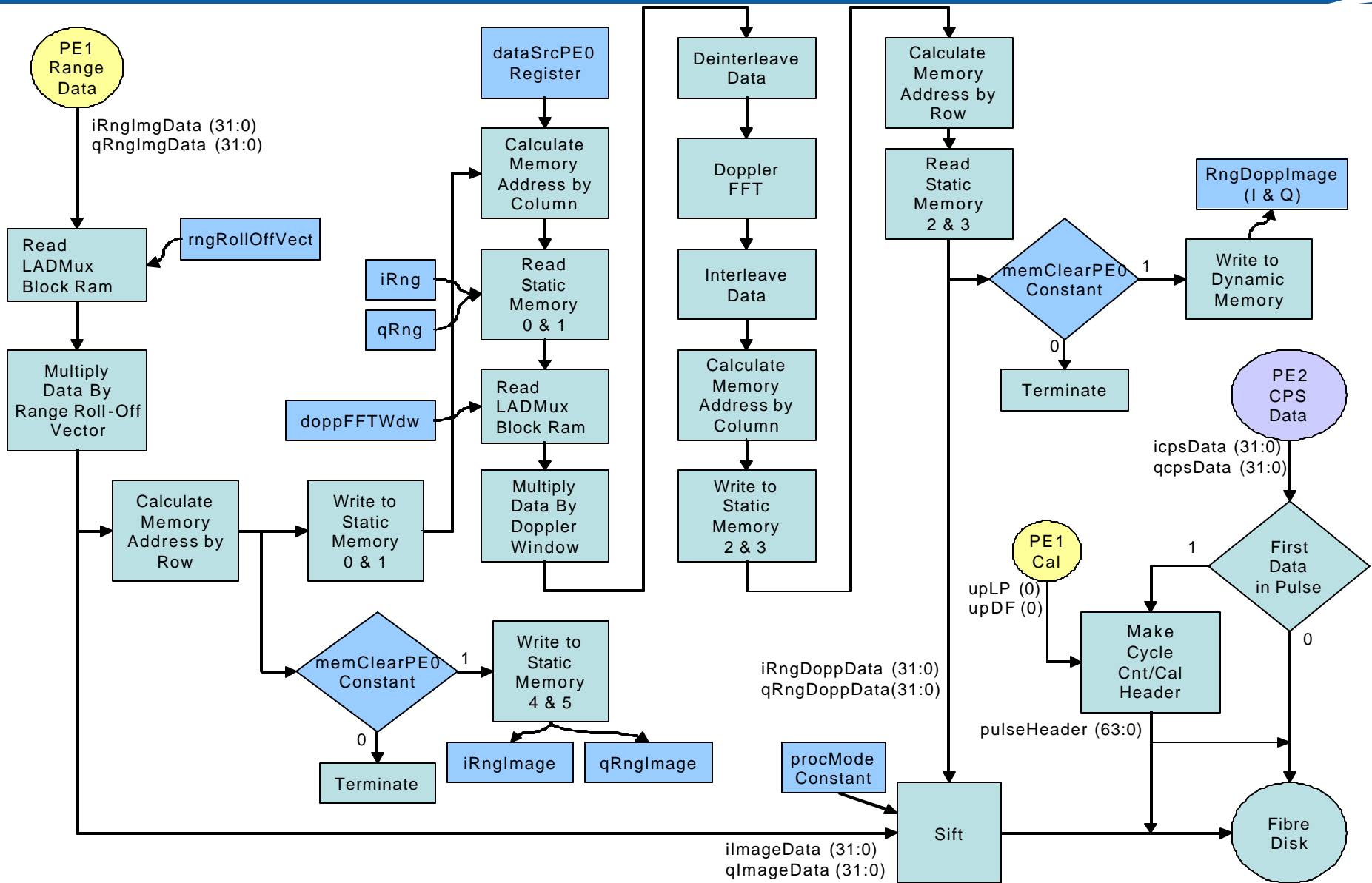

PE0 Allocated Memory Diagram

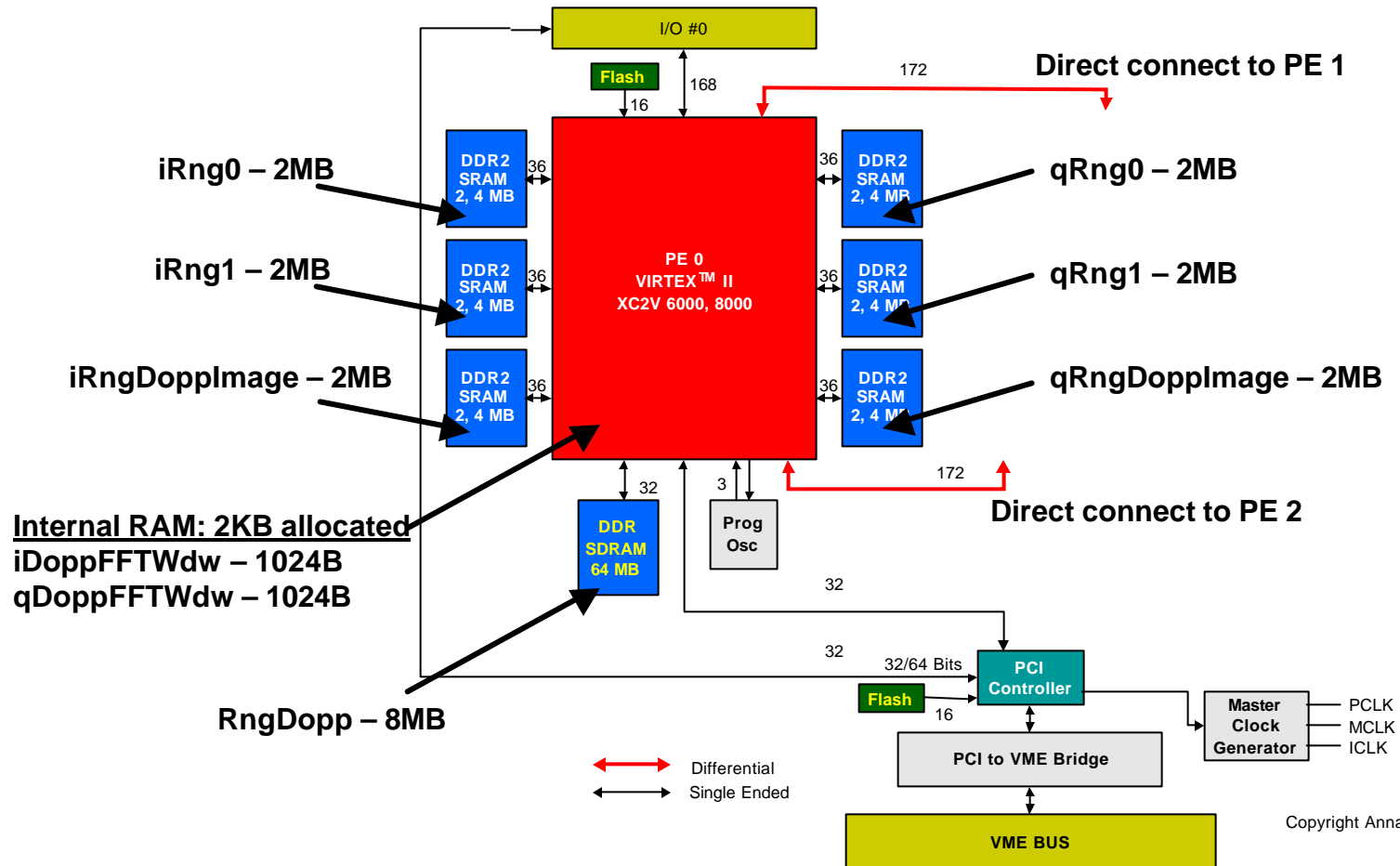

Copyright Annapolis Micro Systems, Inc. 2002

FPGA Design Time: CoreFire™ vs. VHDL

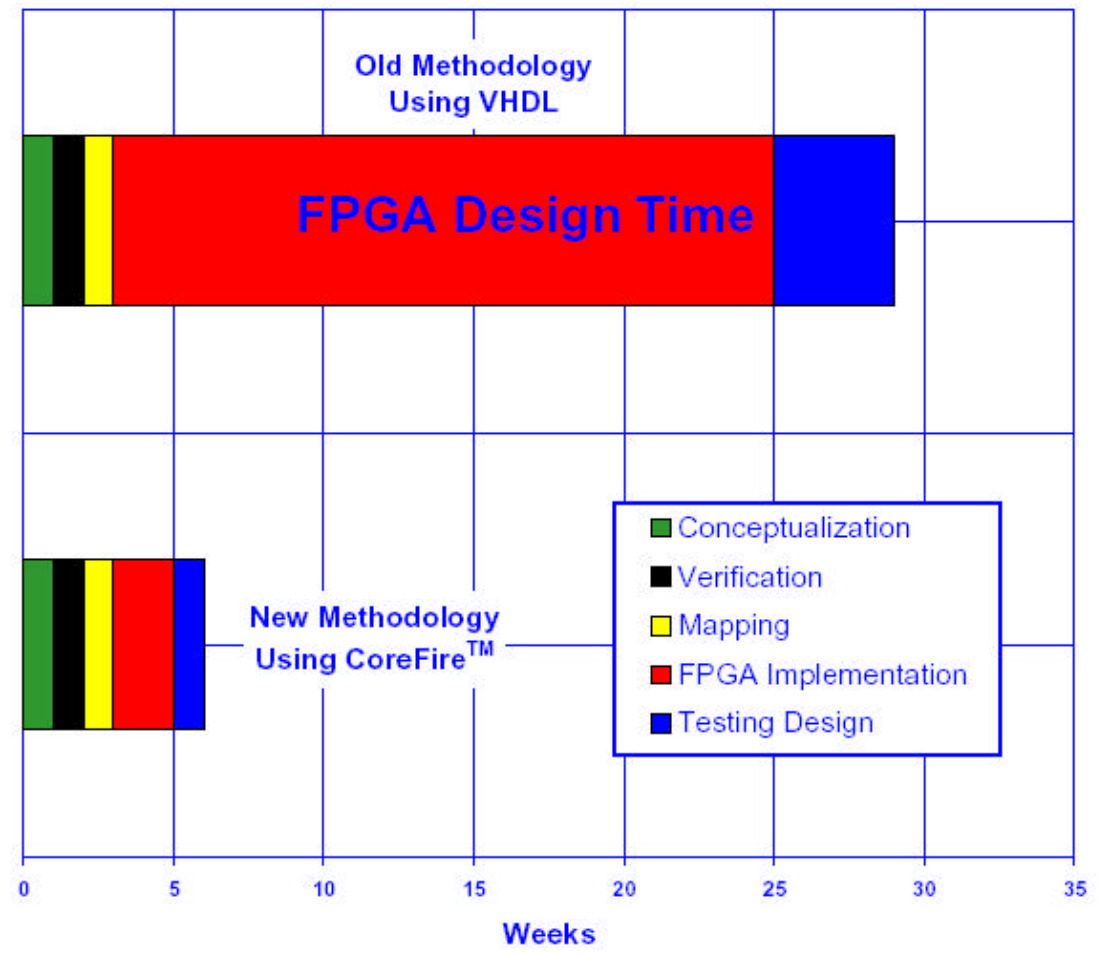

ampCorrCombine Macro Amplitude Correction and I/Q Combine

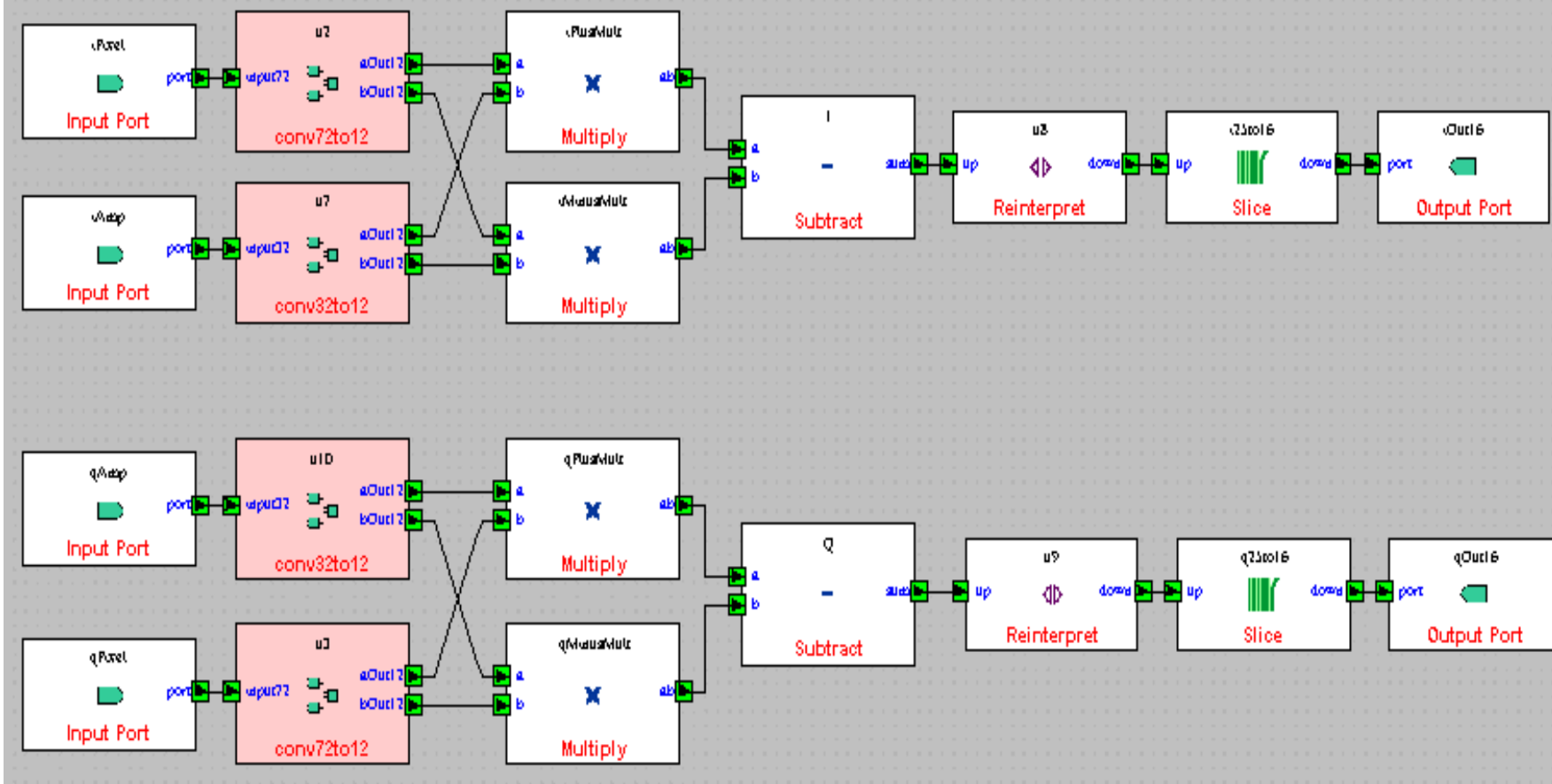

PCS Testing: CoreFire Debugger



CoreFire™ Application Debugger includes windows for monitoring and manipulating data flow

CoreFire Debug - PeTarget.Pe1

File View Options Help

Pass 1 Update none Step 10 Clear

Name	Value	Status	Pass	Ready	Enabled	Cycle	iDataPost...	iSInt	qDataPost...	qSInt	writeAddr...	iDirectFFT	iNegPre	qDirectFFT	qNegPre
iDataPostFFT32	0	Invalid	0	true	<input checked="" type="checkbox"/>	1	??	-2	??	0	0	??	??	??	??
iSInt	-3	Valid	0	true	<input checked="" type="checkbox"/>	2	??	2	??	-1	1	??	-2	??	0
qDataPostFFT32	0	Invalid	0	true	<input checked="" type="checkbox"/>	3	??	-1	??	3	2	??	-2	??	1
qSInt	-2	Valid	0	true	<input checked="" type="checkbox"/>	4	??	-2	??	-5	3	??	-1	??	3
writeAddress	16	Invalid	0	true	<input checked="" type="checkbox"/>	5	??	8	??	4	4	??	2	??	5
iDirectFFT	0	Invalid	0	true	<input checked="" type="checkbox"/>	6	??	-4	??	2	5	??	8	??	4
iNegPre	5	Valid	0	true	<input checked="" type="checkbox"/>	7	??	-2	??	0	6	??	4	??	-2
qDirectFFT	0	Invalid	0	true	<input checked="" type="checkbox"/>	8	??	0	??	0	7	??	-2	??	0
qNegPre	4	Valid	0	true	<input checked="" type="checkbox"/>	9	??	-2	??	-4	8	??	0	??	0
						10	??	0	??	-2	9	??	-2	??	-4
						11	??	2	??	1	10	??	0	??	2
						12	??	2	??	-4	11	??	2	??	1
						13	??	1	??	7	12	??	-2	??	4
						14	??	0	??	-5	13	??	1	??	7
						15	??	2	??	4	14	??	0	??	5
						16	??	-3	??	6	15	??	2	??	4
						17	??	-5	??	-7	16	??	3	??	-6

10:20 AM PE Reset Total 30 Cycle 20

PeTarget.Pe1 - Register Viewer

Help

Update single

numPix LAD 1038 (0x0000040e)
 0 Read 255 Again

numPix_div_by2 LAD 1028 (0x00000404)
 0 Read 127 Again

iData - Memory Viewer 32 bits

File Set Help

iData Update single

Address 0 Dwords 128 Format SInt

Address	0	1	2	3
0	196606	-65537	-262136	65534
4	65534	131074	1	-196606
8	131067	-196603	-65533	131070
12	-131072	-65529	0	524284
16	393211	-327683	-196599	196607
20	65534	-131068	-327680	6
24	-131074	327683	-131074	393216
28	655349	65535	65537	262140
32	196607	589817	-65538	65538
36	-131075	-131068	-65536	-327674
40	-458747	327680	262142	-65536
44	65535	-65533	0	-458748
48	-262135	-65535	65537	65532

View 0(0x0) for 128 DWORDS.

Wildstar II FFT Example



FFT Example Scenario

- **CoreFire project for PE1**
 - Data read from memory on Wildstar II board
 - FFT operation
 - Data written to memory on Wildstar II board
- **Java program**
 - Data read from file
 - Data written to memory on Wildstar II board
 - Data read from memory on Wildstar II board
 - Data written to file
- **CoreFire Debugger**
 - Kicks off the Wildstar II board processing
 - Memory and register viewers show data during the processing
- **IView Tool**
 - Compare output data file with expected results

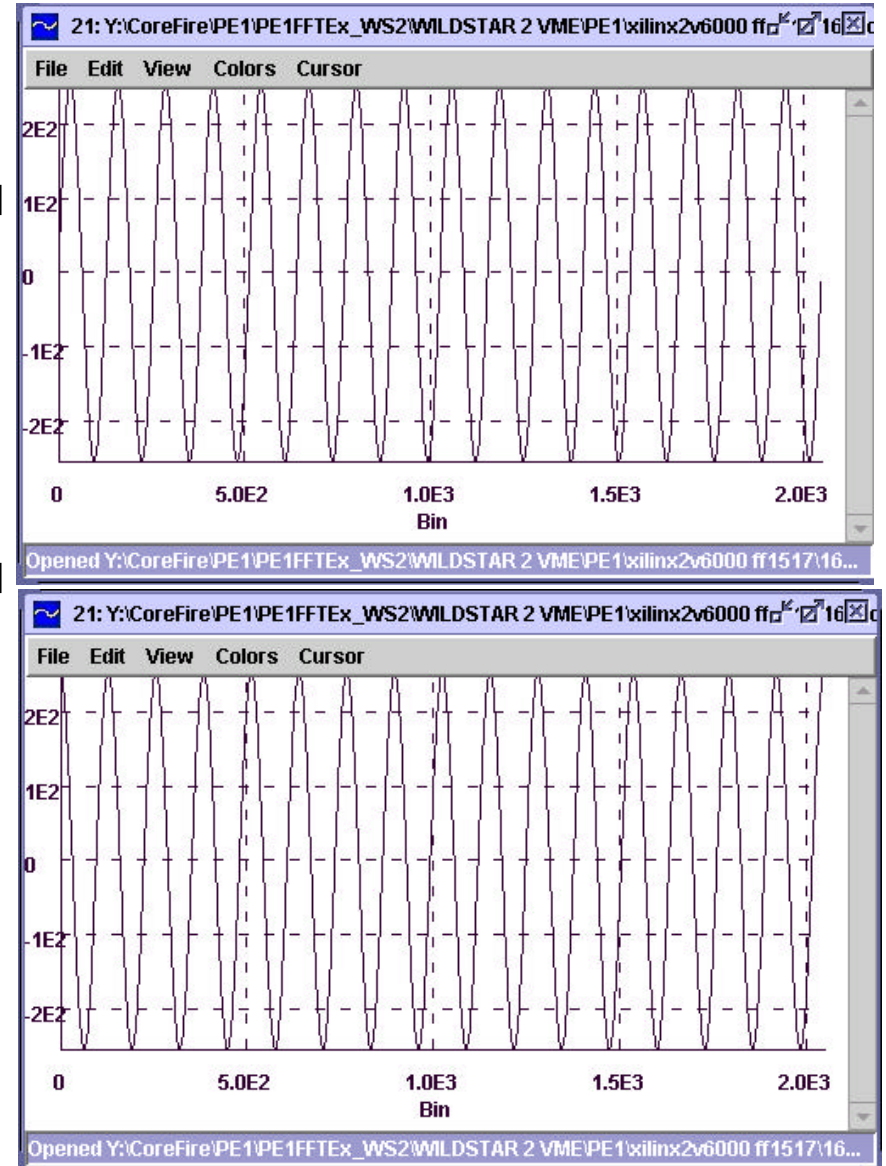

Wildstar II FFT Example



FFT done in SW

FFT done on Wildstar board

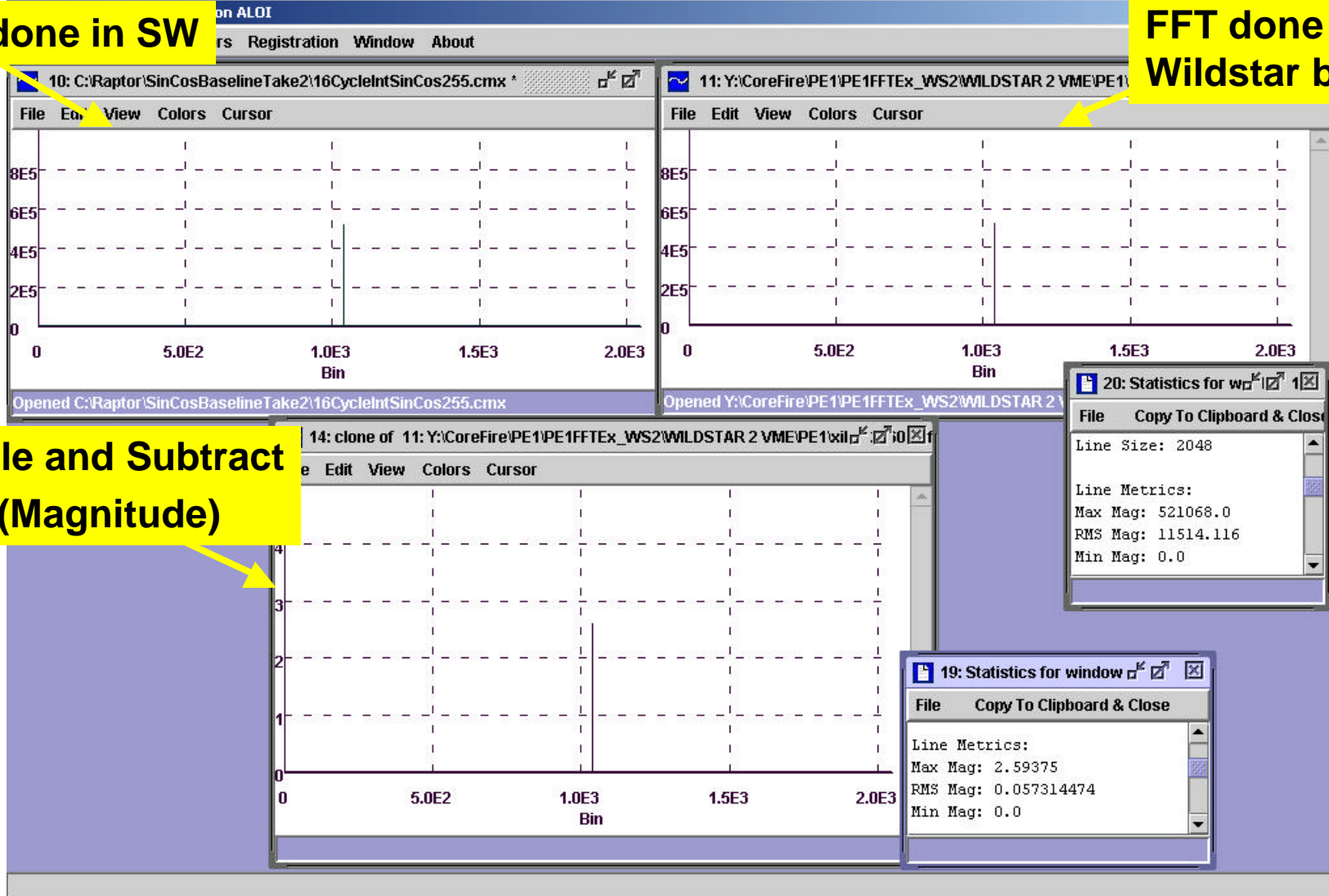

Scale and Subtract (Magnitude)

Peak to RMS = 139 dB

- **Essex has been able to implement an extremely complex, computationally intensive radar processing task in:**
 - **Embedded optical hardware and**
 - **Embedded DSP/FPGA hardware**
- **This approach saves space, development time, software, development costs and maintenance costs.**
- **The AOP hardware allows the use of new arbitrary classes of waveforms for improved ballistic missile discrimination.**

Wrap-up / Questions