

**FINAL REPORT
SEPTEMBER 2004**

REPORT NO. 04-19-2



**TRANSPORTABILITY TESTING OF THE INTERMODAL
STORAGE AND TRANSPORT FRAMES (ISTF-2s),
TP-94-01,
“TRANSPORTABILITY TESTING PROCEDURES”**

Prepared for:

Distribution Unlimited:

U.S. Army Defense Ammunition Center
ATTN: SJMAC-DET
1 C Tree Road
McAlester, OK 74501



**VALIDATION ENGINEERING DIVISION
MCALESTER, OKLAHOMA 74501-9053**

AVAILABILTY NOTICE

A copy of this report will be furnished each attendee on automatic distribution. Additional copies or authority for reprinting may be obtained by written request from:

Director
U.S. Army Defense Ammunition Center
ATTN: SJMAC-DEV
1 C Tree Road, Bldg. 35
McAlester, OK 74501-9053

DISTRIBUTION INSTRUCTIONS

Destroy this report when no longer needed. Do not return.

Citation of trade names in this report does not constitute an official endorsement.

The information contained herein will not be used for advertising purposes.

REPORT NO. 04-19-2
TRANSPORTABILITY TESTING OF THE INTERMODAL
STORAGE AND TRANSPORT FRAMES (ISTF-2s)
TP-94-01, REV. 2, JUNE 2004,
"TRANSPORTABILITY TESTING PROCEDURES"

SEPTEMBER 2004

ABSTRACT

The U.S. Army Defense Ammunition Center (DAC), Validation Engineering Division (SJMAC-DEV), was tasked by the Transportation Engineering Division (SJMAC-DET) to conduct transportability testing on the Intermodal Storage and Transport Frame (ISTF-2) manufactured by Mobile Shelter Systems, Inc. The testing was conducted in accordance with TP-94-01, Revision 2, June 2004 "Transportability Testing Procedures."

The objective of the testing was to evaluate the ISTF-2s, when transportability tested in accordance with TP-94-01, Revision 2, June 2004.

The ISTF-2s, without interlocks, are satisfactory for the transport of ammunition. However, due to extremely tight tolerances we do not recommend that the RIBS cradles be used to block and brace the ISTF-2s in an end-opening intermodal container. Additionally, the **interlock devices are not approved** for ammunition transport. Testing of the interlocks was conducted for evaluation purposes only.

Prepared by:

Reviewed by:

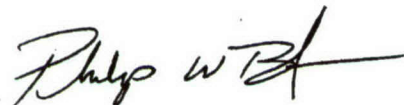

PHILIP W. BARICKMAN
Lead Validation Engineer

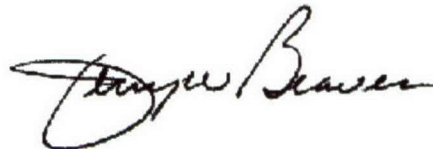

JERRY W. BEAVER
Chief, Validation Engineering Division

U.S. ARMY DEFENSE AMMUNITION CENTER

VALIDATION ENGINEERING DIVISION
MCALESTER, OK 74501-9053

REPORT NO. 04-19-2

**Transportability Testing of the Intermodal Storage
and Transport Frames (ISTF-2),
TP-94-01, Revision 2, June 2004 "Transportability Testing Procedures"**

TABLE OF CONTENTS

PART	PAGE NO.
1. INTRODUCTION	1-1
A. BACKGROUND	1-1
B. AUTHORITY	1-1
C. OBJECTIVE	1-1
D. CONCLUSION	1-1
2. ATTENDEES	2-1
3. TEST EQUIPMENT	3-1
4. TEST PROCEDURES	4-1
A. RAIL TEST	4-1
B. ON/OFF ROAD TESTS	4-3
1. HAZARD COURSE	4-3
2. ROAD TRIP	4-4
3. PANIC STOPS	4-4
4. WASHBOARD COURSE	4-4
C. OCEAN-GOING VESSEL TEST. 80 DEGREE TILT TEST	4-4
5. TEST RESULTS	5-1
5.1 TESTING DATE -10-12 AUGUST 2004	5-1
A. RAIL TEST	5-2
B. ON/OFF ROAD TESTS	5-4
1. HAZARD COURSE	5-4
2. ROAD TRIP	5-5
3. PANIC STOPS	5-5
4. HAZARD COURSE	5-5
5. WASHBOARD COURSE	5-6
C. OCEAN-GOING VESSEL TEST. 80 DEGREE TILT TEST	5-6
D. CONCLUSION	5-7

5.2 TESTING DATE –16-18 AUGUST 2004	5-8
A. RAIL TEST	5-9
B. ON/OFF ROAD TESTS	5-11
1. HAZARD COURSE	5-11
2. ROAD TRIP	5-12
3. PANIC STOPS	5-12
4. HAZARD COURSE	5-12
5. WASHBOARD COURSE	5-12
C. OCEAN-GOING VESSEL TEST. 80 DEGREE TILT TEST	5-13
D. CONCLUSION	5-14
5.3 TESTING DATE –19 AUGUST 2004	5-15
A. ON/OFF ROAD TESTS	5-16
1. HAZARD COURSE	5-16
2. ROAD TRIP	5-17
3. PANIC STOPS	5-17
4. HAZARD COURSE	5-17
5. WASHBOARD COURSE	5-18
B. CONCLUSION	5-19
6. DRAWINGS	6-1

PART 1 – INTRODUCTION

A. BACKGROUND. The U.S. Army Defense Ammunition Center (DAC), Validation Engineering Division (SJMAC-DEV), was tasked by the Transportation Engineering Division (SJMAC-DET) to conduct transportability testing on the Intermodal Storage and Transport Frame (ISTF-2s) manufactured by Mobile Shelter Systems, Inc. The testing was conducted in accordance with TP-94-01, Revision 2, June 2004 “Transportability Testing Procedures.”

B. AUTHORITY. This test was conducted IAW mission responsibilities delegated by the U.S. Army Joint Munitions Command (JMC), Rock Island, IL. Reference is made to the following:

1. AR 740-1, 15 June 2001, Storage and Supply Activity Operation.
2. OSC-R, 10-23, Mission and Major Functions of U.S. Army Defense Ammunition Center (DAC) 21 Nov 2000.

C. OBJECTIVE. The objective of the testing was to evaluate the ISTF-2s, when transportability tested in accordance with TP-94-01, Revision 2, June 2004.

D. CONCLUSION. The ISTF-2s, without interlocks, are satisfactory for the transport of ammunition. However, due to extremely tight tolerances we do not recommend that the RIBS cradles be used to block and brace the ISTF-2s in an end-opening intermodal container. Additionally, the **interlock devices are not approved** for ammunition transport. Testing of the interlocks was conducted for evaluation purposes only.

PART 2 - ATTENDEES

ATTENDEE

MAILING ADDRESS

Philip Barickman
DSN 956-8992
(918) 420-8992

Director
U.S. Army Defense Ammunition Center
ATTN: SJMAC-DEV
1 C Tree Road, Bldg. 35
McAlester, OK 74501-9053

Michael S. Bartosiak
Mechanical Engineer
DSN 956-8083
(918) 420-8083

Director
U.S. Army Defense Ammunition Center
ATTN: SJMAC-DET
1 C Tree Road, Bldg. 35
McAlester, OK 74501-9053

Frank Chan
(973) 724-4783

U.S. Army Armament Research
Development and Engineering Center
Logistics Research &
Engineering Directorate
Picatinny, NJ 07806

Rob Kim
(973) 724-7235

U.S. Army Armament Research
Development and Engineering Center
Logistics Research &
Engineering Directorate
Picatinny, NJ 07806

Bob Forrester
(973) 724-2042

U.S. Army Armament Research
Development and Engineering Center
Logistics Research &
Engineering Directorate
Picatinny, NJ 07806

CW3 Barney Sadler
(973) 724-2539

U.S. Army Armament Research
Development and Engineering Center
Logistics Research &
Engineering Directorate
Picatinny, NJ 07806

Michael Ruff
(732) 866-2253

Naval Surface Warfare Center
Naval PHST Center
201 Highway 34 South
Colts Neck, NJ 07722

Richard Eaves
(732) 866-2906

Naval Surface Warfare Center
Naval PHST Center
201 Highway 34 South
Colts Neck, NJ 07722

James F. Mitchell
(757) 229-9482

Mobile Shelter Systems Inc.
4039 Ironbound Road
Williamsburg, VA 23188

Dwight Tennyson
(757) 880-5309

Mobile Shelter Systems, Inc.
4039 Ironbound Road
Williamsburg, VA 23188

Bill DeMent
(904) 874-4726

Mobile Shelter Systems, Inc.
4039 Ironbound Road
Williamsburg, VA 23188

Tim Lewis
(208) 342-2357

Mobile Shelter Systems Inc.
118 East Williams Street
Boise, ID 83706

Kjetil R. Waag
(+47) 33 36 17 84

Mobile Shelter Systems AS
Fossens Senter
N-3160 Stokke,
Norway

Svein Rene
(+47) 33 36 06 90

Mobile Shelter Systems AS
Industrigata 3
N-3161 Stokke,
Norway

Marshall Moore
(813) 223-5800

Tampa Armature Works
1910 Ola Avenue
Tampa, FL 33602

Michael Sternett
(813) 732-2123

Tampa Armature Works
1910 Ola Avenue
Tampa, FL 33602

PART 3 - TEST EQUIPMENT

1. Intermodal Storage and Transport Frame (ISTF-2s)
Manufactured by Mobile Shelter Systems, Inc.
Weight: 455 pounds
Length: 51-7/8 inches
Width: 41-3/4 inches
Height: 45 inches

2. Truck, Tractor
5-Ton, 6 X 6
Model #: XM818 without winch
ID #: 05E-37770-0124-12331
Weight: 19,260 pounds

3. Truck, Tractor
5 Ton, 6 X 6
Model #: XM818 with winch
Manufactured by General Products Division, Jeep Corporation
ID #: 05A-74971-C124-13529
Weight: 20,955 pounds

4. Semitrailer, flatbed, breakbulk/container transporter, 22.5 ton
Model #: M871
Manufactured by Southwest Truck Body, St. Louis, MO
ID #: NX03PJ – 0063
NSN: 2330 00 122 6799
Weight: 15,630 pounds

5. Semitrailer, flatbed, breakbulk/container transporter, 34 ton
Model #: M872A1
Manufactured by Heller Truck Body Corporation, Hillsdale, NJ
ID #: 11-1505 NX05NZ
NSN: 2330 01 109 8006
Weight: 19,240 pounds

6. Intermodal Container
ID # CMCU 200006-8
Date of Manufacture: 06/99
Manufactured by Charleston Marine Containers, Charleston, SC
Tare Weight: 4870 pounds
Maximum Gross Weight: 67,200 pounds

7. Container Roll-In/Out Platform (CROP)
Model Number: M3
Manufactured by Summa Technologies Incorporated
NSN: 3990 01 442 2751
Tare Weight: 3650 Pounds

8. Container Roll-In/Out Platform (CROP)
Model Number: M3A1
Manufactured by Hyundai Precision America
Tare Weight: 4000 Pounds

PART 4 - TEST PROCEDURES

The test procedures outlined in this section were extracted from TP-94-01, "Transportability Testing Procedures," Revision 2, June 2004, for validating tactical vehicles and outloading procedures used for shipping munitions by tactical truck, railcar, and ocean-going vessel.

The rail impact will be conducted with the loaded intermodal container secured directly to the railcar. Inert (non-explosive) items were used to build the load. The test loads were prepared using the blocking and bracing procedures proposed for use with munitions (**see Part 6 for procedures**). The weight and physical characteristics (weights, physical dimensions, center of gravity, etc.) of the test loads were similar to live (explosive) ammunition.

A. RAIL TEST. RAIL IMPACT TEST METHOD. The test load or vehicle will be secured to a flatcar. The equipment needed to perform the test will include the specimen (hammer) car, four empty railroad cars connected together to serve as the anvil, and a railroad locomotive. The anvil cars will be positioned on a level section of track with air and hand brakes set and with draft gears compressed. The locomotive unit will push the specimen car toward the anvil at a predetermined speed, then disconnect from the specimen car approximately 50 yards away from the anvil cars allowing the specimen car to roll freely along the track until it strikes the anvil. This will constitute an impact. Impacting will be accomplished at speeds of 4, 6, and 8.1 mph in one direction and at a speed of 8.1 mph in the reverse direction. The tolerance for the speeds is plus 0.5 mph, minus 0.5 mph for the 4 mph and 6 mph impacts, and plus 0.5 mph, minus 0 mph for the 8.1 mph impacts. The impact speeds will be determined by using an electronic counter to measure the time for the specimen car to traverse an 11-foot distance immediately prior to contact with the anvil cars (see Figure 1).

ASSOCIATION OF AMERICAN RAILROADS (AAR)

STANDARD TEST PLAN

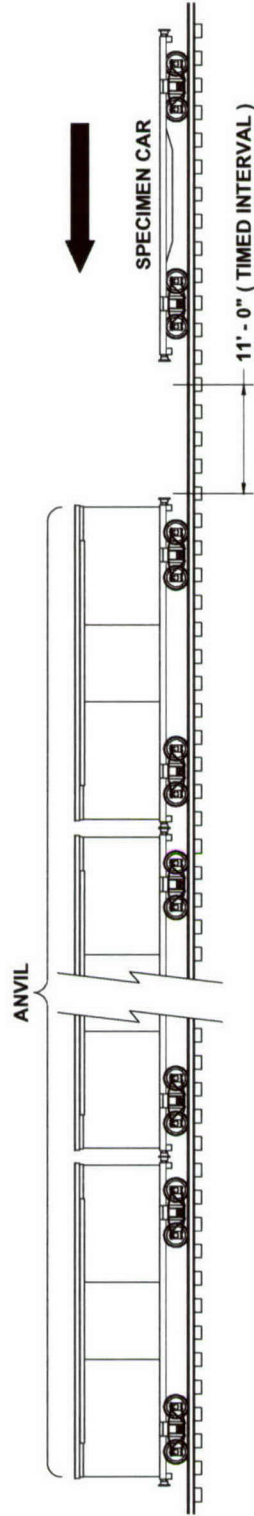

4 BUFFER CARS (ANVIL)
WITH DRAFT GEAR
COMPRESSED AND AIR BRAKES IN A SET
POSITION

ANVIL CAR TOTAL WT. 250,000 LBS (APPROX)

SPECIMEN CAR IS RELEASED BY SWITCH ENGINE
TO

ATTAIN: IMPACT NO. 1 @ 4 MPH

IMPACT NO. 2 @ 6 MPH

IMPACT NO. 3 @ 8.1 MPH

THEN THE CAR IS REVERSED AND RELEASED BY
SWITCH ENGINE TO ATTAIN:

IMPACT NO. 4 @ 8.1 MPH

Figure 1. Rail Impact Sketch

B. ON/OFF ROAD TEST.

1. HAZARD COURSE. The test load or vehicle will be transported over the 200-foot-long segment of concrete-paved road consisting of two series of railroad ties projecting 6 inches above the level of the road surface. The hazard course will be traversed two times (see Figure 2).

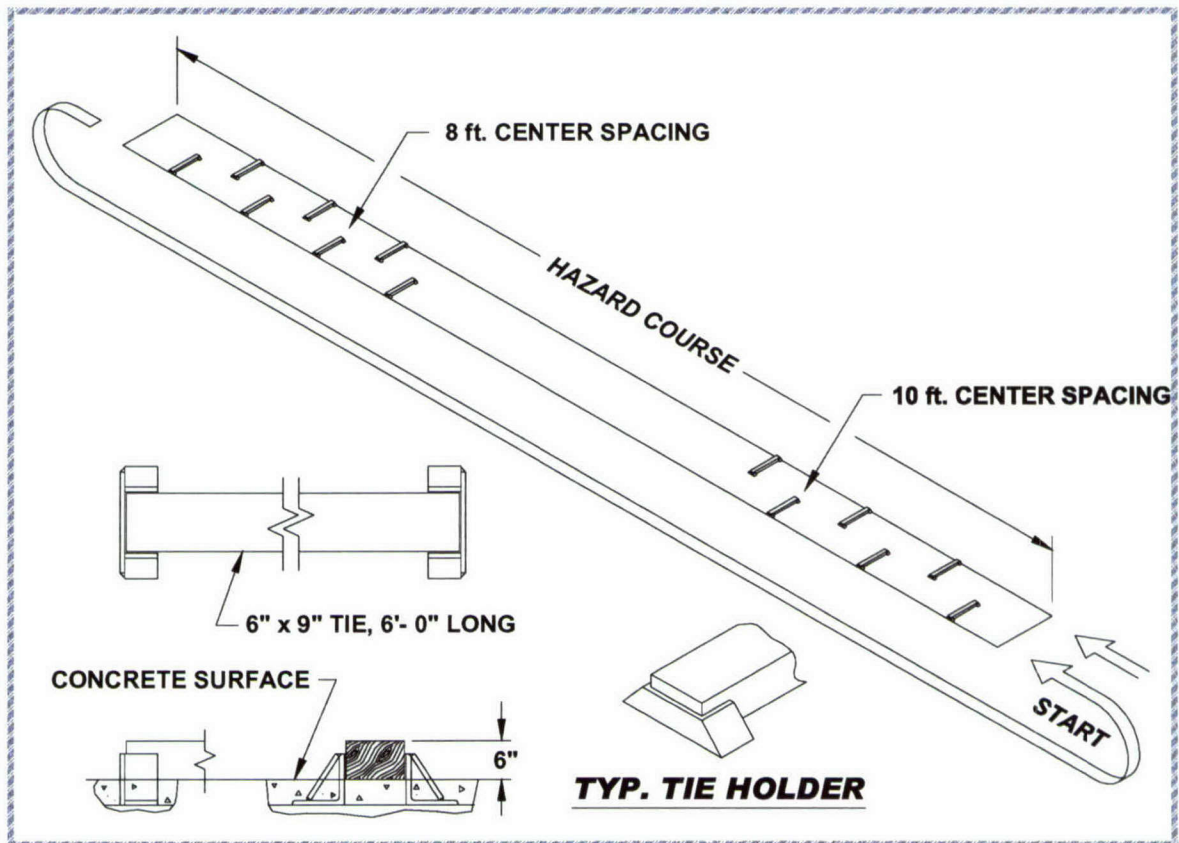

Figure 2. Hazard Course Sketch

- a. The first series of 6 ties are spaced on 10-foot centers and alternately positioned on opposite sides of the road centerline for a distance of 50 feet.
- b. Following the first series of ties, a paved roadway of 75 feet separates the first and second series of railroad ties.

c. The second series of 7 ties are spaced on 8-foot centers and alternately positioned on opposite sides of the road centerline for a distance of 50 feet.

d. The test load is driven across the hazard course at speeds that will produce the most violent vertical and side-to-side rolling reaction obtainable in traversing the hazard course (approximately 5 mph).

2. ROAD TRIP. The test load or vehicle will be transported for a distance of 30 miles over a combination of roads surfaced with gravel, concrete, and asphalt. The test route will include curves, corners, railroad crossings and stops and starts. The test load or vehicle will travel at the maximum speed for the particular road being traversed, except as limited by legal restrictions.

3. PANIC STOPS. During the road trip, the test load or vehicle will be subjected to three (3) full airbrake stops while traveling in the forward direction and one in the reverse direction while traveling down a 7 percent grade. The first three stops are at 5, 10, and 15 mph while the stop in the reverse direction is approximately 5 mph. This testing will not be required if the Rail Impact Test is performed.

4. WASHBOARD COURSE. The test load or vehicle will be driven over the washboard course at a speed that produces the most violent response in the vertical direction.

C. OCEAN-GOING VESSEL TEST. 80-DEGREE TILT TEST. The test load (specimen) shall be positioned on level terrain with the bottom corner fittings resting on timbers so the entire container is supported solely by the bottom corner fittings. The timbers shall be oriented parallel to the end rails of the container and extend 2 feet beyond the corner fittings on each side. Using two mobile cranes and appropriate rigging, the container shall be rotated (tilted) using the bottom corner fittings on one side as a fulcrum. The rigging (slings) of one

crane shall be attached to the bottom corner fittings of the long side and the rigging (slings) of the second crane shall be attached to the top corner fittings on the opposite side. The tilting shall be accomplished by lifting the bottom corner fittings with the first crane so the container rotates about the opposite bottom corner fittings (fulcrum). Lifting/rotating by the first crane is continued until the center of gravity passes over the fulcrum, at which point the second crane shall provide support to the container and lower the container to the 80 degrees, plus or minus 2 degrees position. Rotation shall be accomplished smoothly at a slow speed so the container sidewall is subjected only to the static force of the interior load. The crane booms shall be adjusted to maintain a rear vertical suspension of the rigging at all times. In the case of end-opening type containers, at least one door (lower side of tilted container) must be closed and fastened throughout the test. The container shall be held in the tilted position for a minimum of two minutes. At which time, observations of both the container structure and the interior load shall be made. When the test is completed, the container shall be returned to its upright position using the same manner and care in handling.

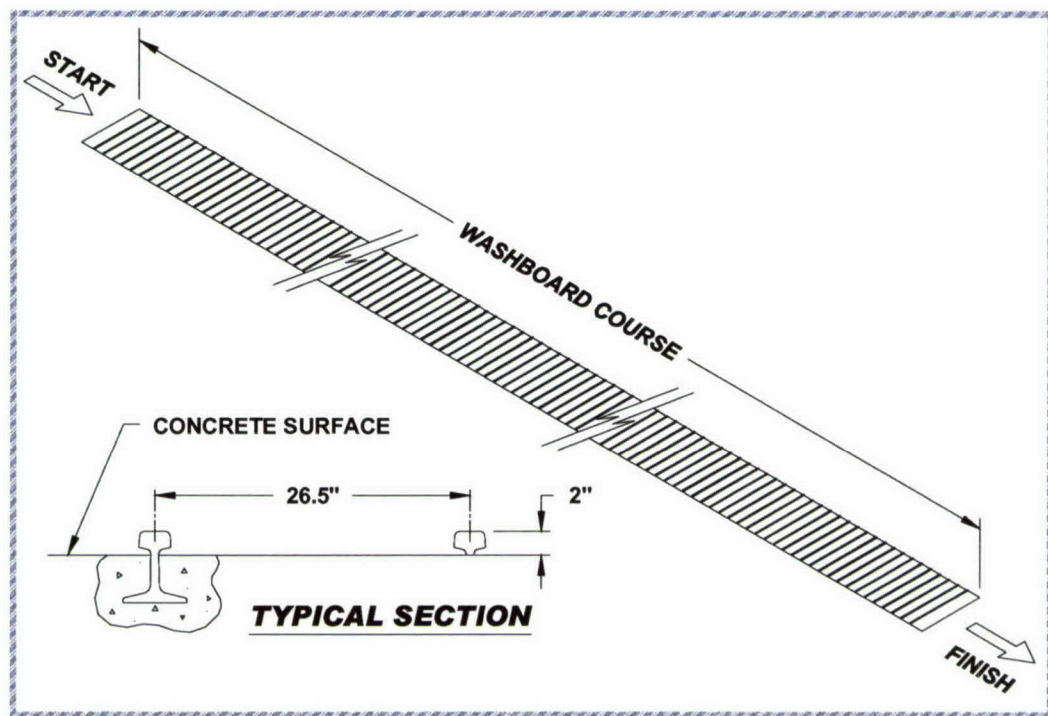

Figure 3. Washboard Course Sketch

PART 5 - TEST RESULTS

5.1

Payload: 16 ISTF-2s in an End-opening Intermodal Container.

Testing Date: 10-12 August 2004

Gross Weight: 41,000 pounds (including intermodal container)



Photo 1. ISTF-2s in an End-opening Intermodal Container

A. RAIL TEST.



Photo 2. Rail Impact Testing of the ISTF-2s in an End-opening Intermodal Container (Prior to Testing)

Description	Weight
Flatcar Number: DODX 42353	85,000 lbs.
ISTF-2s and End-opening Intermodal Container	41,000 lbs.
M1 Flatrack with MLRS Pods	28,265 lbs.
Total Specimen Wt.	154,265 lbs.
Buffer Car (four cars)	257,900 lbs.

Figure 4.

Remarks: Figure 4 lists the test components and weights of the items used during the Rail Impact Tests.

Impact Number	Avg. Velocity (mph)
1	3.4
2	4.9
3	6.6
4	8.8
5	7.9
6	8.9

Figure 5.

Remarks:

1. Figure 5 lists the average speeds of the specimen car immediately prior to impact with the anvil. Impacts #5 and #6 are the reverse impacts.
2. Impacts #1 and #5 were each determined to be a “no test” due to the insufficient velocity at impact. The tests were repeated.
3. Following Impact #2 a cap from the Rapid ISO Bracing System (RIBS) locking pin finger holds came off.
4. Following Impact #3 the ISTF-2s moved 0.125 inches in the direction of impact.
5. Following Impact #4 the ISTF-2s moved an additional 0.125-0.375 inches in the direction of impact. The vertical stay of the RIBS cradle moved 0.5 inches and the RIBS beams bowed.
6. Following Impact #5 the ISTF-2s moved 1.75-2.5 inches in the direction of impact.



Photo 3. ISTF-2s Movement

B. ON/OFF ROAD TESTS.

1. HAZARD COURSE.



Photo 4. Hazard Course Testing of the ISTF-2s in an End-Opening Intermodal Container

Pass No.	Elapsed Time	Avg. Velocity (mph)
1	29 Seconds	5.1
2	30 Seconds	4.9

Figure 6.

Remarks:

1. Figure 6 lists the average speeds of the test load through the Hazard Course.
2. Inspection following Pass #1 revealed that the ISTF-2s had moved toward the container door 0.5 inches (toward the rear of the trailer).

2. ROAD TRIP:

Remarks:

1. The Road Trip was conducted between the Road Hazard Course Passes #2 and #3.
2. Inspection following the Road Trip revealed no movement of the payload or damage.

3. PANIC STOPS: Testing was not required since the load was rail impact tested.

4. HAZARD COURSE:

Pass No.	Elapsed Time	Avg. Velocity (mph)
3	29 Seconds	5.1
4	28 Seconds	5.3

Figure 7.

Remarks:

1. Figure 7 lists the average speeds of the test load through the Hazard Course.

2. Inspection following Pass #4 revealed that the ISTF-2s had moved toward the container door an additional 0.25 inches (toward the rear of the trailer).

5. WASHBOARD COURSE:

Remark: Inspection following the completion of the Washboard Course revealed no additional movement or damage.



Photo 5. Washboard Course Testing of the ISTF-2s in an End-Opening Container

C. OCEAN-GOING VESSEL TEST. 80-DEGREE TILT TEST.

Remark: Inspection following the completion of the tilt testing revealed no additional movement or damage.



Photo 6. Tilt Testing of ISTF-2s in an End-opening Container

D. CONCLUSION: As tested the ISTF-2s successfully completed transportability testing in an end-opening intermodal container. Installation of the cradles of the RIBS was difficult due to the limited space and tolerances between the rows of the ISTF-2s. The cradles could not be installed efficiently and safely. The cradles had to be shoved and banged into position using a forklift. After completion of the testing the cradles had to be pulled out of position using a chain and forklift. Damage did occur to the cradles when they were removed. Therefore, blocking and bracing of the ISTF-2s, using the RIBS cradles, is not acceptable.

5.2

Payload: 8 ISTF-2s in an End-opening Intermodal Container on a Hyundai CROP.

Testing Date: 16-18 August 2004

Gross Weight: 26,780 pounds (including ISTF-2s, intermodal container and CROP)

Notes: The ISTF-2s were held in place using twelve 3-inch-wide CROP straps. The ISTF-2s were not interlocked together. The tiedowns were located at the 1, 2, 3, 4, 5, 8, 11, 14, 15, 16, 17, and 18 anchor locations located on the CROP.

The test sketch shows the forward blocking assembly by the CROP A-frame. During the load build, the strap going over the assembly could not be achieved at that position. Therefore, the assembly was switched to the rear of the load as shown in Photo 7. The corner strapping board assembly, as shown in the test sketch (See Part 6), was not necessary for this load.

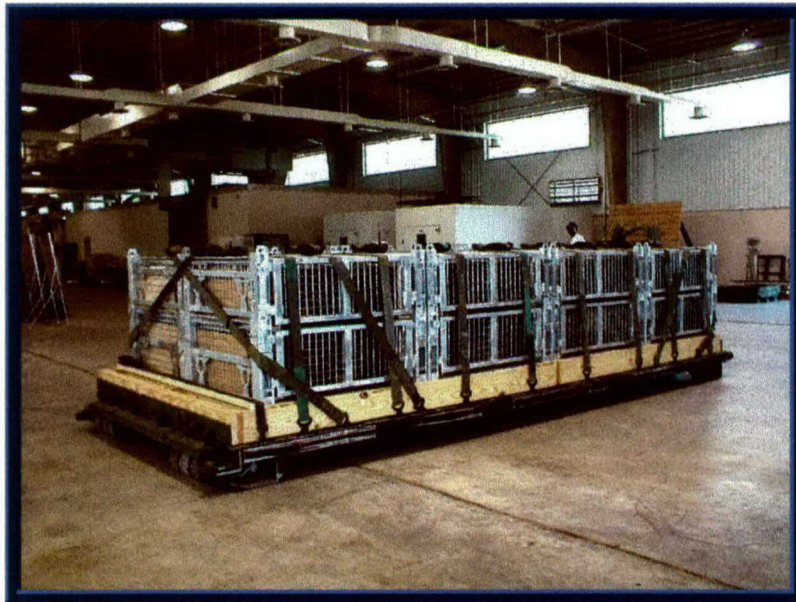

Photo 7. ISTF-2s on a Hyundai CROP

A. RAIL TEST.



**Photo 8. Rail Impact Testing of the ISTF-2s on a Hyundai CROP
(Prior to Testing)**

Description	Weight
Flatcar Number: DODX 42353	85,000 lbs.
ISTF-2s, End-opening Intermodal Container and Hyundai CROP	26,780 lbs.
M1 Flatrack with MLRS Pods	28,265 lbs.
Total Specimen Wt.	140,045 lbs.
Buffer Car (four cars)	257,900 lbs.

Figure 8.

Remarks: Figure 8 lists the test components and weights of the items used during the Rail Impact Tests.

Impact Number	Avg. Velocity (mph)
1	4.8
2	5.5
3	8.3
4	7.8
5	8.5

Figure 9.

Remarks:

1. Figure 9 lists the average speeds of the specimen car immediately prior to impact with the anvil. Impacts #4 and #5 are the reverse impacts.
2. Impact #4 was determined to be a “no test” due to the insufficient velocity at impact. The test was repeated.
3. Following Impact #1 the ISTF-2s moved 0.625 inches in the direction of impact.
4. Following Impact #2 the ISTF-2s moved an additional 0.125 inches in the direction of impact.
5. Following Impact #4 the ISTF-2s moved 0.75 inches in the direction of impact and returned to the original starting position.

B. ON/OFF ROAD TESTS.

1. HAZARD COURSE.



Photo 9. Hazard Course Testing of the ISTF-2s on a Hyundai CROP

Pass No.	Elapsed Time	Avg. Velocity (mph)
1	29 Seconds	5.1
2	26 Seconds	5.7

Figure 10.

Remarks:

1. Figure 10 lists the average speeds of the test load through the Hazard Course.
2. Inspections following each pass revealed no additional movement or damage.

2. ROAD TRIP:

Remarks:

1. The Road Trip was conducted between the Road Hazard Course Passes #2 and #3.
2. Inspection following the completion of the road trip revealed no additional movement or damage.

3. PANIC STOPS: Testing was not required since the load was rail impact tested.

4. HAZARD COURSE:

Pass No.	Elapsed Time	Avg. Velocity (mph)
3	25 Seconds	5.9
4	26 Seconds	5.7

Figure 11.

Remarks:

1. Figure 11 lists the average speeds of the test load through the Hazard Course.
2. Inspections following each pass revealed no additional movement or damage.

5. WASHBOARD COURSE:

Remark: Inspection following the completion of the Washboard Course testing revealed no additional movement or damage.



Photo 10. Washboard Course Testing of the ISTF-2s on a Hyundai CROP

C. OCEAN-GOING VESSEL TEST. 80-DEGREE TILT TEST.

Remark: Inspection following the completion of the tilt testing revealed no additional movement or damage.



Photo 11. Tilt Testing of ISTF-2s on a Hyundai CROP

D. CONCLUSION: As tested, the ISTF-2s successfully completed the transportability testing when secured on a CROP in an end-opening intermodal container. The ISTF-2s were not interlocked during the testing. Also, twelve 3-inch CROP straps were used to secure the ISTF-2s to the Hyundai CROP.

5.3

Payload: 8 ISTF-2s on a Summa CROP.

Testing Date: 19 August 2004

Gross Weight: 21,800 pounds (including ISTF-2s and CROP)

Notes: The testing was conducted as evaluation testing of the interlocks on the ISTF-2s. The testing was not conducted to verify the interlocks for ammunition transport. The tiedowns were located at the 2, 3, 4, 7, 13, 15, and 17 anchor locations on the CROP. The corner strapping assemblies, as shown in the test sketch (See Part 6), were not necessary for this load. No aft filler was required for this load. The ISTF-2s were held in place using eight 3-inch-wide CROP straps. The ISTF-2s were interlocked.



Photo 12. ISTF-2s on a Summa CROP

A. ON/OFF ROAD TESTS.

1. HAZARD COURSE.



Photo 13. Hazard Course Testing of the ISTF-2s on a Summa CROP

Pass No.	Elapsed Time	Avg. Velocity (mph)
1	29 Seconds	7.2
2	30 Seconds	7.0

Figure 12.

Remarks:

1. Figure 12 lists the average speeds of the test load through the Hazard Course.
2. Inspections following each pass revealed no movement or damage.

2. ROAD TRIP:

Remarks:

1. The Road Trip was conducted between the Road Hazard Course Passes #2 and #3.
2. Inspection following the completion of the road trip revealed no movement or damage.

3. PANIC STOPS:

Remarks:

1. The Panic Stops were conducted during the Road Trip.
2. Inspection following the completion of the panic stops revealed no movement or damage.

4. HAZARD COURSE:

Pass No.	Elapsed Time	Avg. Velocity (mph)
3	30 Seconds	7.0
4	34 Seconds	6.1

Figure 13.

Remarks:

1. Figure 13 lists the average speeds of the test load through the Hazard Course.
2. Inspections following Pass #3 revealed that the ISTF-2s had moved 0.5 inches toward the passenger side.



Photo 14. Pass #3 Movement

5. WASHBOARD COURSE:

Remark: Inspection following the completion of the Washboard Course testing revealed no additional movement or damage.



Photo 15. Washboard Course Testing of the ISTF-2s on a Summa CROP

B. CONCLUSION: As tested, the ISTF-2s successfully completed the transportability testing when secured on a CROP. The ISTF-2s were interlocked during the testing. This testing was conducted to evaluate whether transportation forces would cause any damage to the interlocks when secured to the CROP at even a reduced restraint procedure using only eight (8) straps. This testing was not conducted to approve the interlock devices for transportability. Therefore, **the interlock devices are not approved for ammunition transport.**

PART 6 – DRAWINGS

The following test sketches represent the load configuration that was subjected to the test criteria.

LOAD SKETCH FOR THE TRANSPORTABILITY SERIES TESTING OF THE INTERMODAL STORAGE AND TRANSPORT FRAME - TWO PANEL VERSION (ISTF-2) IN A 20 FT END OPENING ISO CONTAINER AND ON A CONTAINER ROLL ON/OFF PLATFORM (CROP)

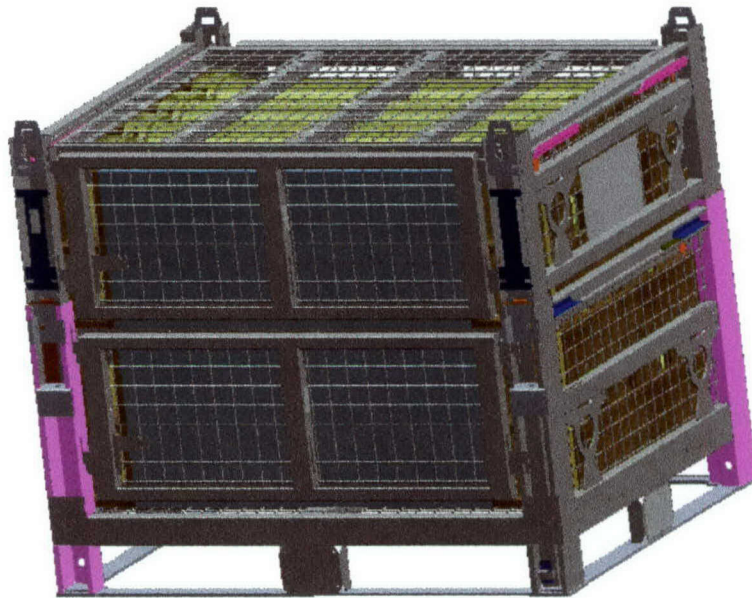

THIS EIGHT PAGE DOCUMENT DEPICTS PROCEDURES FOR UNITIZING THE TEST LOAD FOR THE ISTF-2 TRANSPORTABILITY TESTING.

DRAFT AS OF 8/4

Prepared during August 2004 by:
U.S. Army Defense Ammunition Center
ATTN: SJMAC-DET
McAlester, OK 74501
POC: Mike Bartosiak
DSN 956-8083
Comm (918) 420-8083
Fax (DSN) 956-8811
E-mail: michael.bartosiak@us.army.mil

Gregory L. Willis
Chief, Transportation Engineering Division

● TOP SHELF, TWO FRONT PANELS AND TWO DIVIDERS NOT SHOWN. DIVIDERS WERE NOT USED IN THE LOADS FOR THIS TEST.

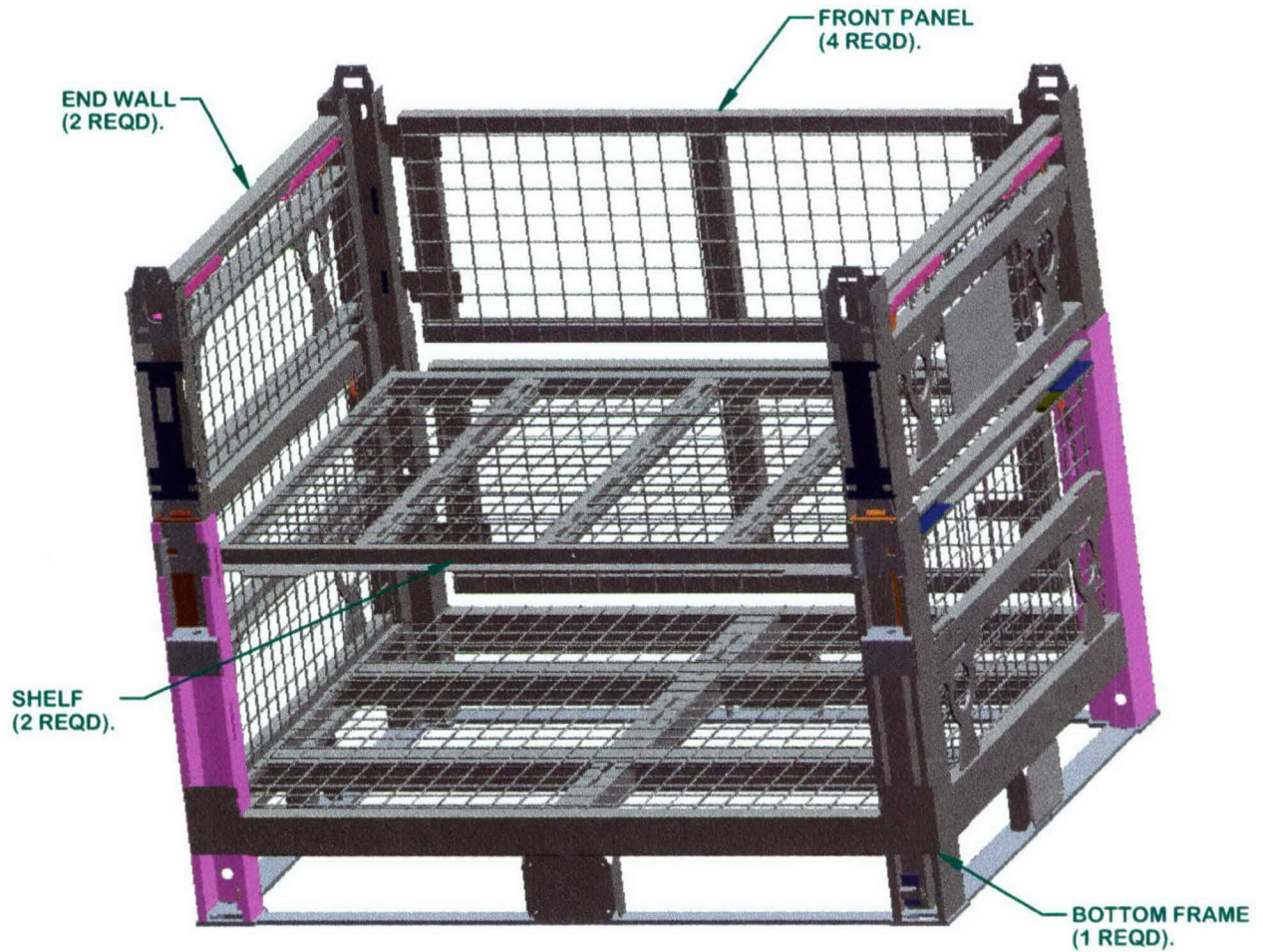

ISTF-2 INTERNAL SETUP

PLACE INTERNAL SHELF IN THE THIRD SHELF SLOT FROM THE BOTTOM OF THE ISTF-2 UNIT.

ISTF-2 DIMENSIONS
OVERALL DIMENSIONS OF THE ISTF-2 UNIT: 52" L X 42" W X 45"H
INSIDE USEABLE DIMENSIONS OF THE ISTF-2 UNIT: 47-5/8" L X 36-3/4" W X 32-3/4" H

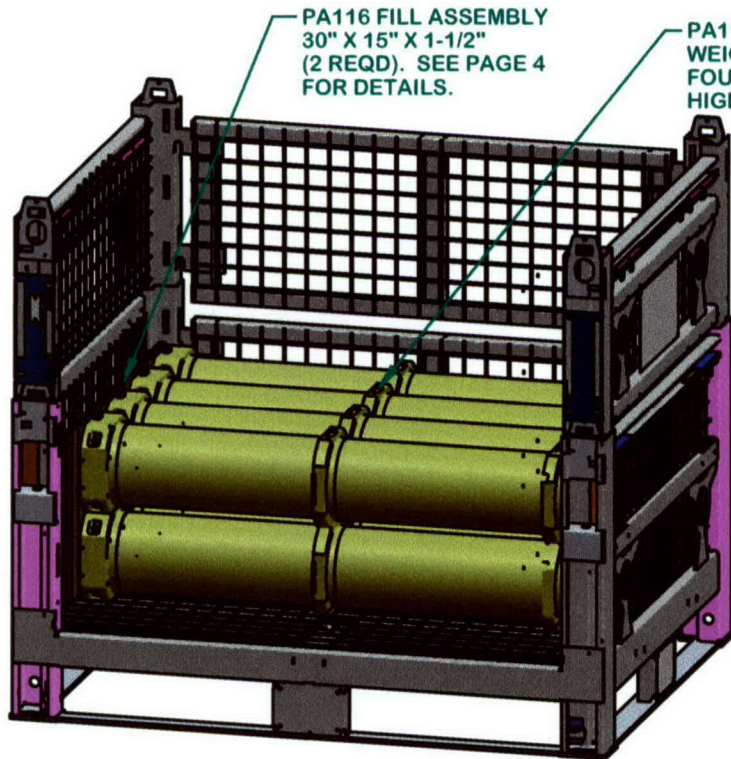

PA116 FILL ASSEMBLY
30" X 15" X 1-1/2"
(2 REQD). SEE PAGE 4
FOR DETAILS.

PA116 CONTAINERS
WEIGHTED TO 75 LB
FOUR STACKS - TWO
HIGH EACH (8 REQD).

ISTF-2 BOTTOM FRAME LOAD STEP 1 TO 2

- ① LOAD PA116 FILL ASSEMBLIES UP AGAINST EACH END WALL.
- ② LOAD THE 8 PA116 CYLINDRICAL METAL CONTAINERS IN FOUR TWO HIGH STACKS AS SHOWN. INTERLOCK THE SIDE LIP GRIPS ON THE PA116 CONTAINERS PROVIDED THERE IS ENOUGH ROOM TO DO SO.

NOTE: THE TOP SHELF, CENTER SHELF AND TWO FRONT PANELS ARE NOT SHOWN FOR CLARITY.

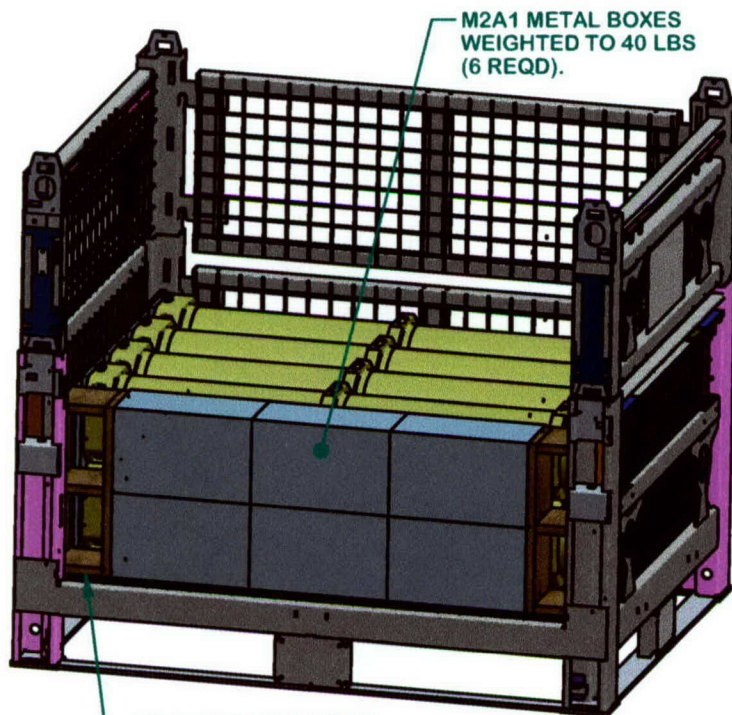

M2A1 METAL BOXES
WEIGHTED TO 40 LBS
(6 REQD).

M2A1 FILL ASSEMBLY
5-3/4" X 15" X 5-1/2"
(2 REQD). SEE PAGE 4
FOR DETAILS.

ISTF-2 BOTTOM FRAME LOAD STEP 3 TO 4

- ③ PLACE THE M2A1 FILL ASSEMBLY UP AGAINST EACH END WALL.
- ④ LOAD THE M2A1 METAL AMMO BOXES AS SHOWN.

NOTE: TOP SHELF, CENTER SHELF, AND TWO FRONT PANELS ARE NOT SHOWN FOR CLARITY.

ISTF-2 BOTTOM FRAME COMPOSITION CHART

PKG TYPE	NO. REQD	WEIGHT EA (LBS)
PA116 CONTAINER	8	75
M2A1 / METAL CAN	6	40
PA116 FILL ASSEMBLY	2	6.7
M2A1 FILL ASSEMBLY	2	3.7
TOTAL WEIGHT	- - - - -	861 LBS (APPROX)

ISTF-2 BOTTOM FRAME LOAD

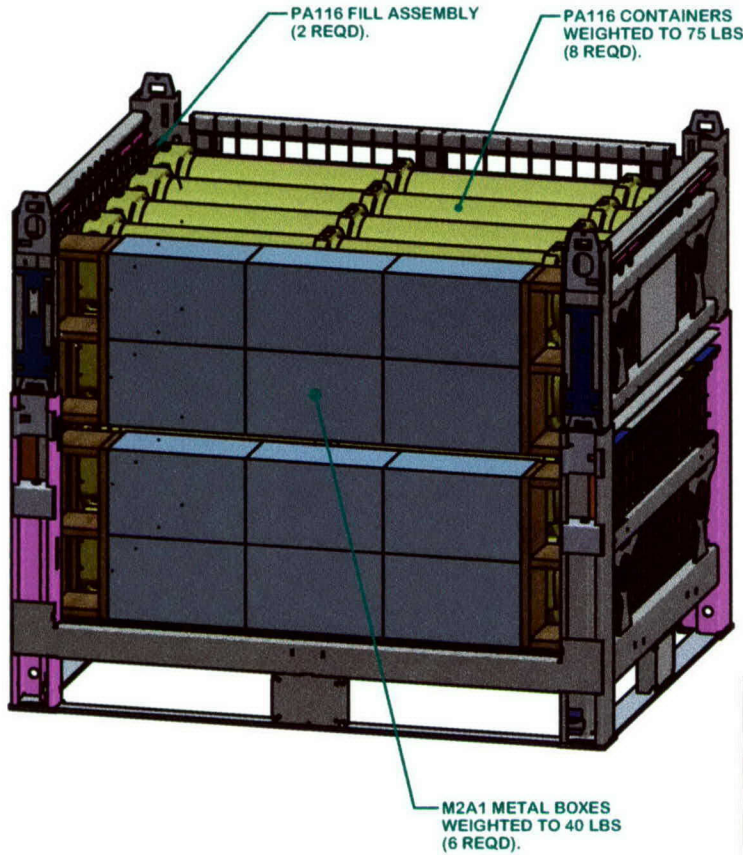

ISTF-2 SHELF LOAD STEP 1 TO 4
(SAME AS BOTTOM FRAME LOAD ON PAGE 3)

- ① LOAD PA116 FILL ASSEMBLIES UP AGAINST EACH END WALL.
- ② LOAD THE 8 PA116 CYLINDRICAL METAL CONTAINERS IN FOUR TWO HIGH STACKS AS SHOWN.
- ③ PLACE THE M2A1 FILL ASSEMBLY UP AGAINST EACH END WALL.
- ④ LOAD THE M2A1 METAL AMMO BOXES AS SHOWN.

ISTF-2 SHELF COMPOSITION CHART		
PGK TYPE	NO. REQD	WEIGHT EA (LBS)
PA116 CONTAINER	8	75
M2A1 / METAL CAN	6	40
PA116 FILL ASSEMBLY	2	6.7
M2A1 FILL ASSEMBLY	2	3.7
TOTAL WEIGHT	- - - - -	861 LBS (APPROX)

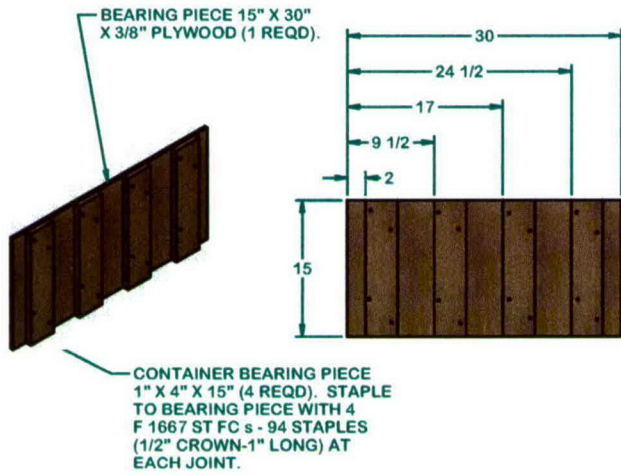

PA116 FILL ASSEMBLY DETAIL
(4 REQD PER ISTF-2 UNIT)

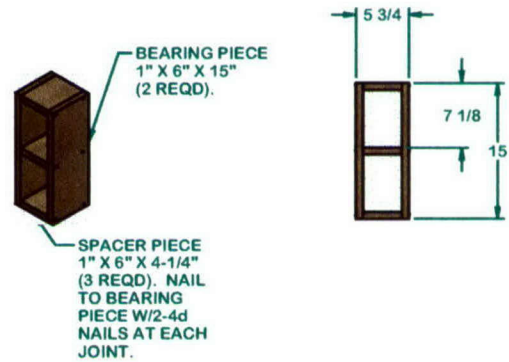

M2A1 FILL ASSEMBLY DETAIL
(4 REQD PER ISTF-2 UNIT)

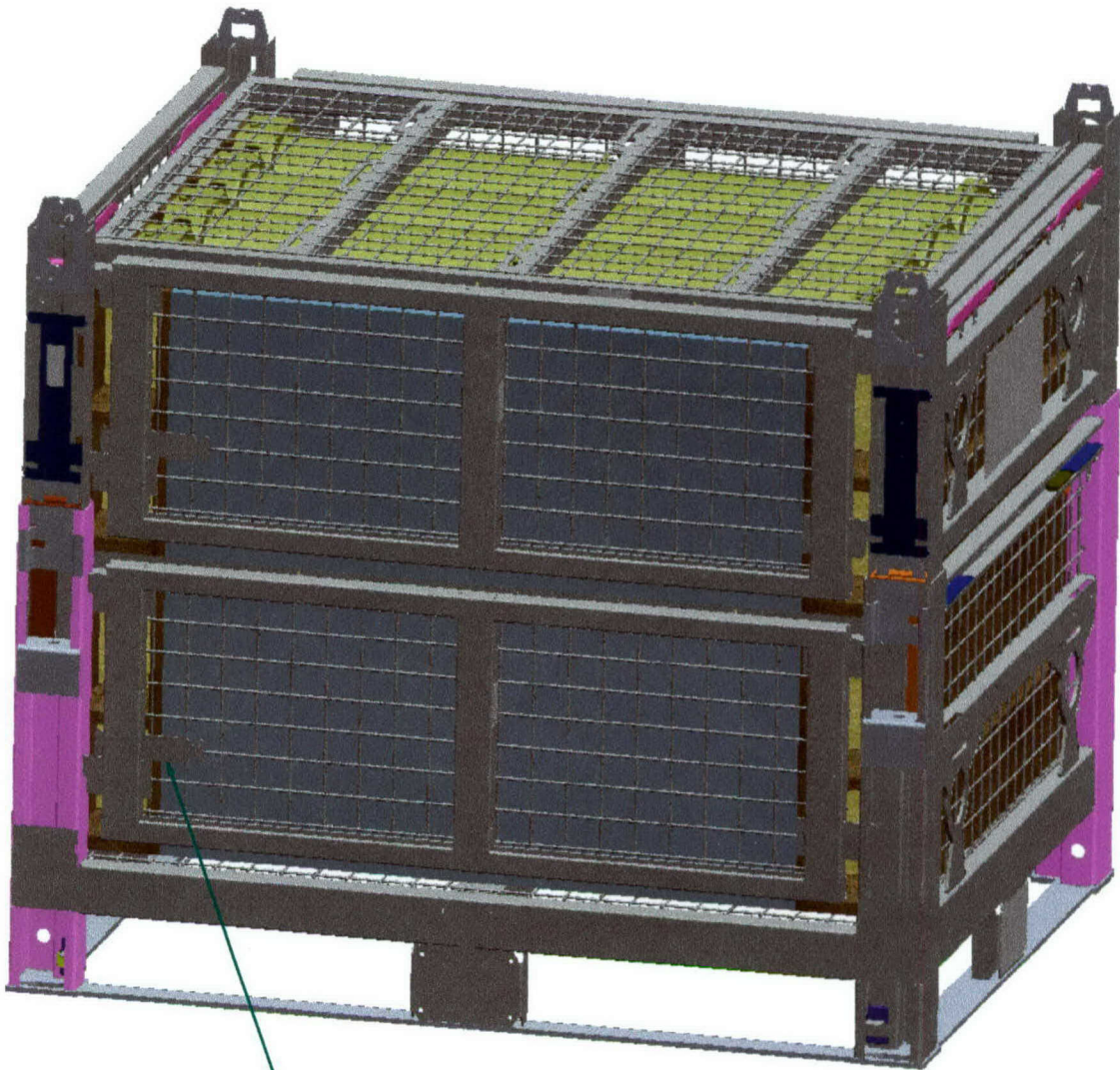

SLIDING FILL PIECE. ENSURE THE SLIDING FILL PIECE ON EACH FRONT PANEL IS SLID OVER AND SECURED WITH THE PROVIDED CANTILEVER PIN.

BILL OF MATERIAL

LUMBER	LINEAR FEET	BOARD FEET
1" X 4"	20	6.7
1" X 6"	14.25	7.2
NAILS	NO. REQD	POUNDS
4d	112	.39
3/8 PLYWOOD ----- 12.5 SQ FT ----- 13 LBS		

ISTF-2 UNIT LOAD

ITEM	QUANTITY	WEIGHT (APPROX)
PA116 CONTAINERS	16	1,200 LBS
M2A1 METAL BOXES	12	480 LBS
DUNNAGE		42 LBS
ISTF-2 UNIT		455 LBS
TOTAL WEIGHT		2,177 LBS

- 16 ISFT-2 UNITS REQUIRED FOR 20FT END OPENING ISO CONTAINER LOAD.
8 ISFT-2 UNITS WILL BE USED ON THE CROP LOAD.

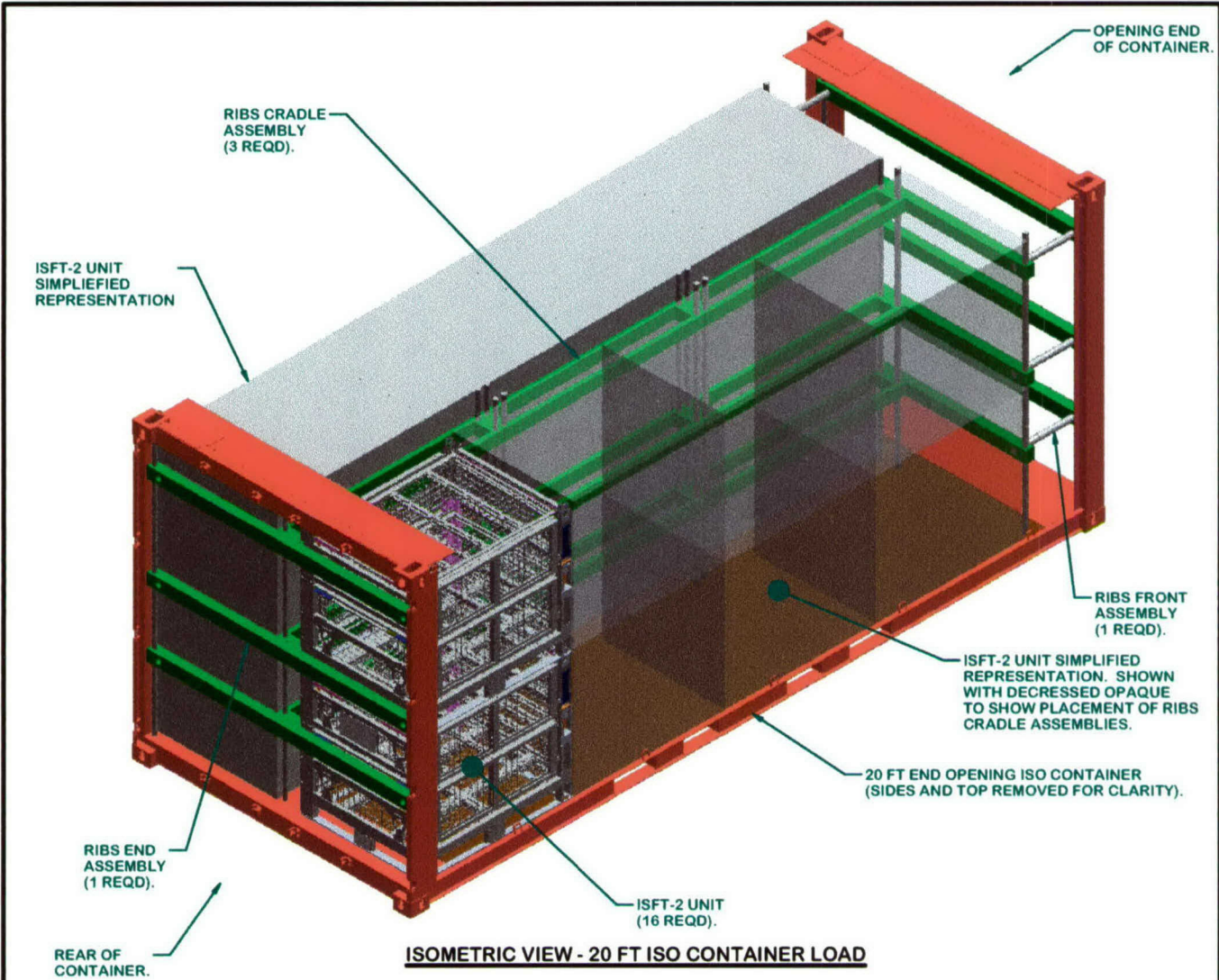

ISOMETRIC VIEW - 20 FT ISO CONTAINER LOAD

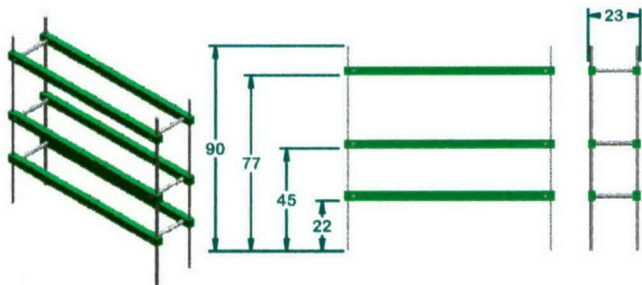

RIBS FRONT ASSEMBLY DETAIL
(1 REQD)

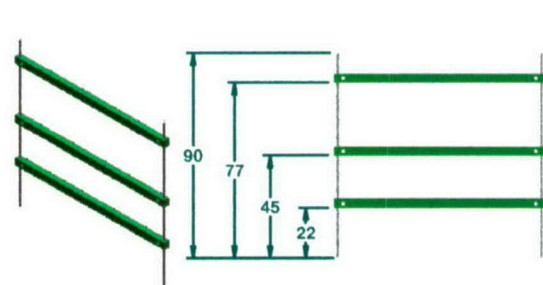

RIBS END ASSEMBLY DETAIL
(1 REQD)

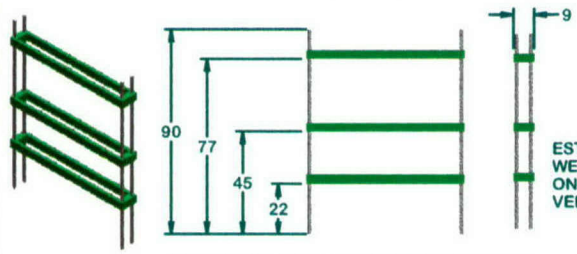

RIBS CRADLE ASSEMBLY DETAIL
(3 REQD)

ESTIMATED WEIGHT ONLY. NEEDS VERIFICATION.

ISTF-2 CONTAINER LOAD

ITEM	QUANTITY	WEIGHT (APPROX)
ISTF-2 UNITS	16	34,928 LBS
RIBS ASSEMBLIES	5	504 LBS
CONTAINER	1	4,700 LBS
TOTAL WEIGHT		40,132 LBS

● THESE ARE A SIMPLIFIED DEPICTIONS OF THE RIBS ASSEMBLIES. THESE DETAILS WERE NOT CREATED FROM A MSS MODEL FILE.

NOTE: POSITION THE ISTF-2 UNITS WITH THE SIDE WITH THE M2A1 BOXES FACING OUTWARDS.

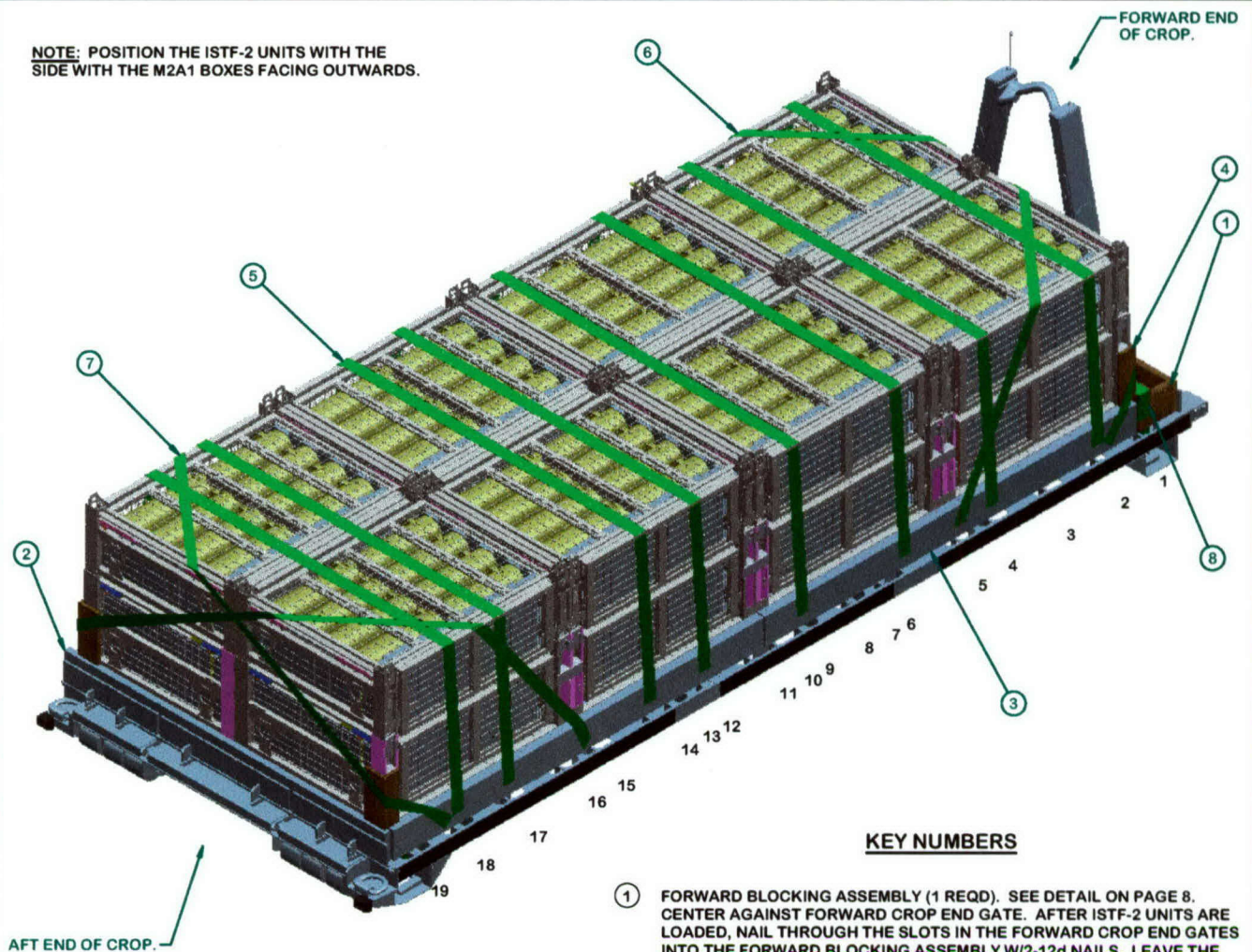

ISOMETRIC VIEW

(KEY NUMBERS CONTINUED)

- ⑦ AFT END RESTRAINT STRAP, 3" WIDE CROP STRAP (2 REQD). INSTALL EACH STRAP TO EXTEND FROM THE EIGHTEENTH TIEDOWN ANCHOR ON ONE SIDE OF THE CROP, AROUND THE END OF THE AFT ISTF-2 UNITS, OVER THE TOP OF THE AFT ISTF-2 UNITS, TO THE FIFTEENTH TIEDOWN ANCHOR ON THE OPPOSITE SIDE OF THE CROP. ALIGN THE SCUFF SLEEVES OVER ALL SHARP EDGES AND FIRMLY TENSION STRAP.
- ⑧ RETAINER STRAP, 2" WIDE WEB STRAP ASSEMBLY (1 REQD). INSTALL TO EXTEND FROM THE FIRST TIEDOWN ANCHOR ON ONE SIDE OF THE CROP, OVER THE TOP OF THE FORWARD BLOCKING ASSEMBLY STRAPPING BOARD, TO THE FIRST TIEDOWN ANCHOR ON THE OPPOSITE SIDE OF THE CROP. ALIGN THE SCUFF SLEEVES OVER ALL SHARP EDGES AND FIRMLY TENSION STRAP.

LOAD AS SHOWN

ITEM	QUANTITY	WEIGHT (APPROX)
ISTF-2 UNIT	8	17,464 LBS
DUNNAGE		209 LBS
CROP		3,800 LBS
TOTAL WEIGHT		21,473 LBS (APPROX)

KEY NUMBERS

- ① FORWARD BLOCKING ASSEMBLY (1 REQD). SEE DETAIL ON PAGE 8. CENTER AGAINST FORWARD CROP END GATE. AFTER ISTF-2 UNITS ARE LOADED, NAIL THROUGH THE SLOTS IN THE FORWARD CROP END GATES INTO THE FORWARD BLOCKING ASSEMBLY W/2-12d NAILS. LEAVE THE NAIL HEADS PROTRUDING THROUGH THE SLOTS TO PROVIDE LATERAL RESTRAINT.
- ② AFT FILLER, 1" OR 2" X 8" X 7'-4" (AS REQD). LAMINATE EACH PIECE TO THE PREVIOUS PIECE W/8 NAILS OF A SUITABLE SIZE (6d NAILS FOR 1" THICK MATERIAL OR 10d NAILS FOR 2" THICK MATERIAL). CENTER AGAINST AFT CROP END GATE AND NAIL THROUGH THE SLOTS IN THE AFT CROP END GATE INTO THE AFT FILLER W/2-12d NAILS. LEAVE THE NAIL HEADS PROTRUDING THROUGH THE SLOTS TO PROVIDE LATERAL AND VERTICAL RESTRAINT.
- ③ SIDE BLOCKING ASSEMBLY (4 REQD). SEE DETAIL ON PAGE 8. INSTALL TWO ON EACH SIDE OF THE CROP ADJACENT TO THE PALLET UNITS.
- ④ CORNER STRAPPING BOARD ASSEMBLY (4 REQD). SEE DETAIL ON PAGE 8. INSTALL TWO EACH OF ASSEMBLY A AND ASSEMBLY B, ON THE CORNERS OF THE ISTF-2 UNITS, WITH BASE OF ASSEMBLY AGAINST THE TOP OF THE SIDE BLOCKING ASSEMBLY AND BEARING PIECE ALONG THE SIDE OF THE LOAD.
- ⑤ HOLD-DOWN STRAP, 3" WIDE CROP STRAP (10 REQD). INSTALL EACH STRAP TO EXTEND FROM THE DESIGNATED TIEDOWN ANCHOR ON ONE SIDE OF THE CROP, OVER THE TOP OF THE ISTF-2 UNITS, TO THE CORRESPONDING TIEDOWN ANCHOR ON THE OPPOSITE SIDE OF THE CROP. ALIGN SCUFF SLEEVES OVER ALL SHARP EDGES AND FIRMLY TENSION STRAP.
- ⑥ FORWARD END RESTRAINT STRAP, 3" WIDE CROP STRAP (2 REQD). INSTALL EACH STRAP TO EXTEND FROM THE SECOND TIEDOWN ANCHOR POSITION ON ONE SIDE OF THE CROP, AROUND THE END OF THE FORWARD ISTF-2 UNITS, OVER THE TOP OF THE FORWARD ISTF-2 UNITS, TO THE FIFTH TIEDOWN ANCHOR ON THE OPPOSITE SIDE OF THE CROP. ALIGN THE SCUFF SLEEVES OVER ALL SHARP EDGES AND FIRMLY TENSION STRAP.

(CONTINUED AT LEFT)

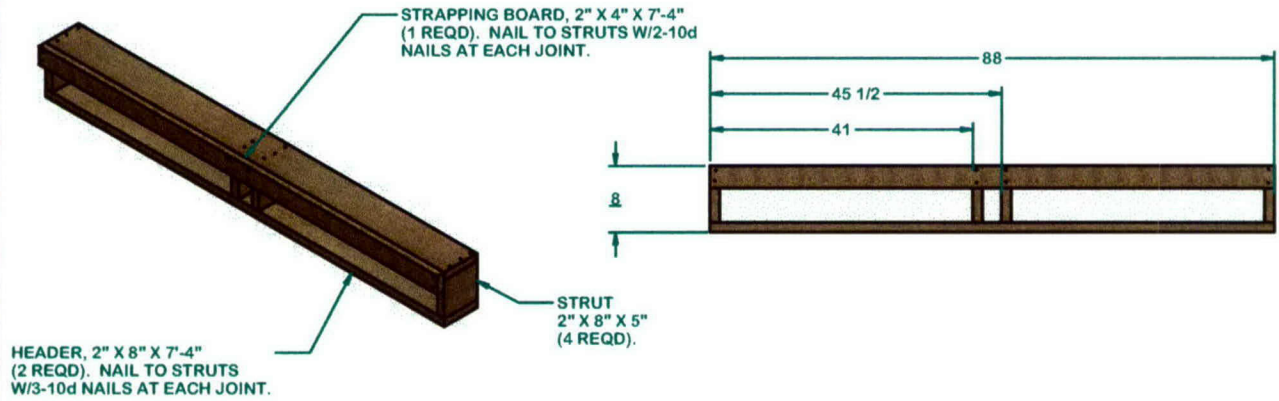

FORWARD BLOCKING ASSEMBLY

(1 REQD)

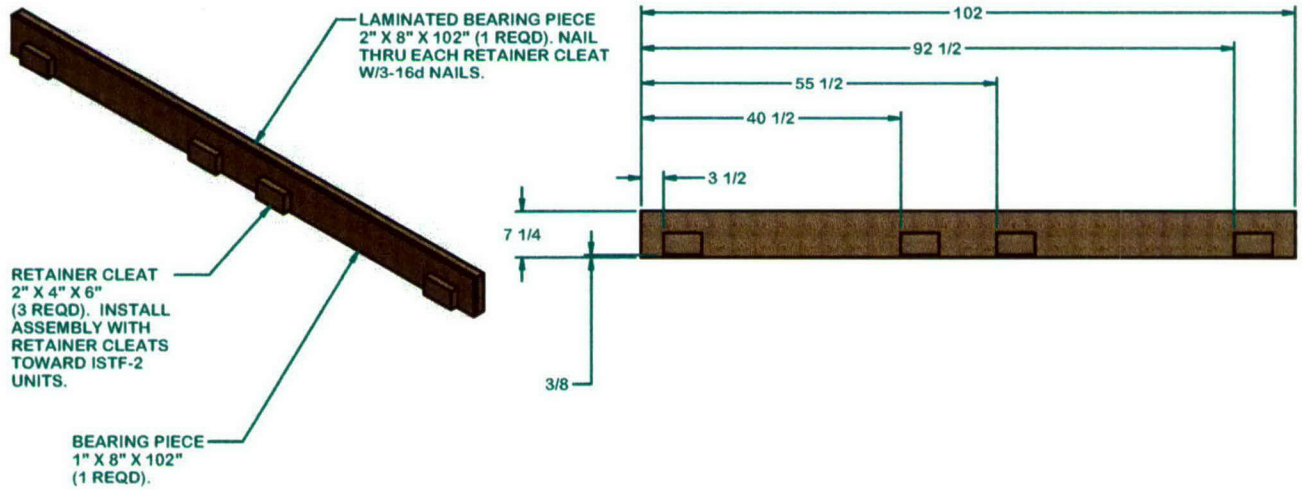

SIDE BLOCKING ASSEMBLY

(4 REQD)

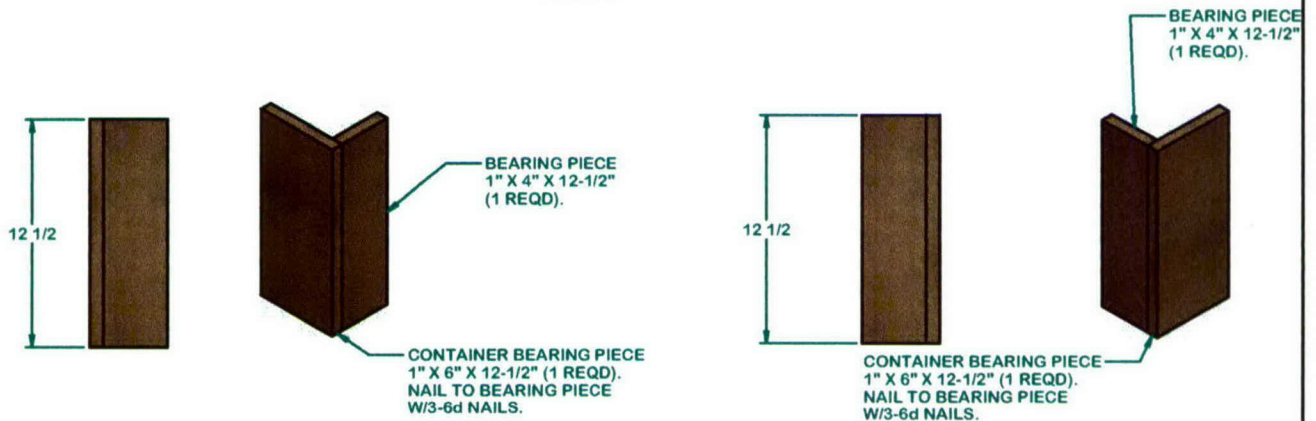

CORNER STRAPPING BOARD ASSEMBLY A

(2 REQD)

CORNER STRAPPING BOARD ASSEMBLY B

(2 REQD)

BILL OF MATERIALS						
LUMBER	LINEAR FEET	BOARD FEET	NAILS	NO. REQD	POUNDS	
1" X 4"	13-1/2	4-1/2	6d	12	NIL	
2" X 4"	8	5-3/8	10d	32	1/2	
1" X 8"	34-3/8	23	16d	48	1	
2" X 8"	50-3/4	67-3/4				
2" WEB STRAP TIEDOWN ASSEMBLY				1 REQD	6 LBS	
2" STEEL EDGE PROTECTOR				8 REQD	1/2 LBS	