



SIMULATIONS FOR DESIGN, SENSING AND CONTROL OF LIQUID COMPOSITE MOLDING PROCESSES

Suresh G. Advani
UD-CCM and UD-ME

Research Funded by Advanced Material Intelligent Processing Center
Established at University of Delaware by Office of Naval Research

UD-CCM • 2 July 2003

Report Documentation Page

Form Approved
OMB No. 0704-0188

Public reporting burden for the collection of information is estimated to average 1 hour per response, including the time for reviewing instructions, searching existing data sources, gathering and maintaining the data needed, and completing and reviewing the collection of information. Send comments regarding this burden estimate or any other aspect of this collection of information, including suggestions for reducing this burden, to Washington Headquarters Services, Directorate for Information Operations and Reports, 1215 Jefferson Davis Highway, Suite 1204, Arlington VA 22202-4302. Respondents should be aware that notwithstanding any other provision of law, no person shall be subject to a penalty for failing to comply with a collection of information if it does not display a currently valid OMB control number.

1. REPORT DATE 26 AUG 2004		2. REPORT TYPE N/A		3. DATES COVERED -	
4. TITLE AND SUBTITLE Simulations For Design, Sensing And Control Of Liquid Composite Molding Processes				5a. CONTRACT NUMBER	
				5b. GRANT NUMBER	
				5c. PROGRAM ELEMENT NUMBER	
6. AUTHOR(S)				5d. PROJECT NUMBER	
				5e. TASK NUMBER	
				5f. WORK UNIT NUMBER	
7. PERFORMING ORGANIZATION NAME(S) AND ADDRESS(ES) University of Delaware Center for Composite Materials Newark, DE 19716				8. PERFORMING ORGANIZATION REPORT NUMBER	
9. SPONSORING/MONITORING AGENCY NAME(S) AND ADDRESS(ES)				10. SPONSOR/MONITOR'S ACRONYM(S)	
				11. SPONSOR/MONITOR'S REPORT NUMBER(S)	
12. DISTRIBUTION/AVAILABILITY STATEMENT Approved for public release, distribution unlimited					
13. SUPPLEMENTARY NOTES See also ADM001700, Advanced Materials Intelligent Processing Center: Phase IV., The original document contains color images.					
14. ABSTRACT					
15. SUBJECT TERMS					
16. SECURITY CLASSIFICATION OF:			17. LIMITATION OF ABSTRACT	18. NUMBER OF PAGES	19a. NAME OF RESPONSIBLE PERSON
a. REPORT unclassified	b. ABSTRACT unclassified	c. THIS PAGE unclassified			

Composite Process Modeling in a Text Book

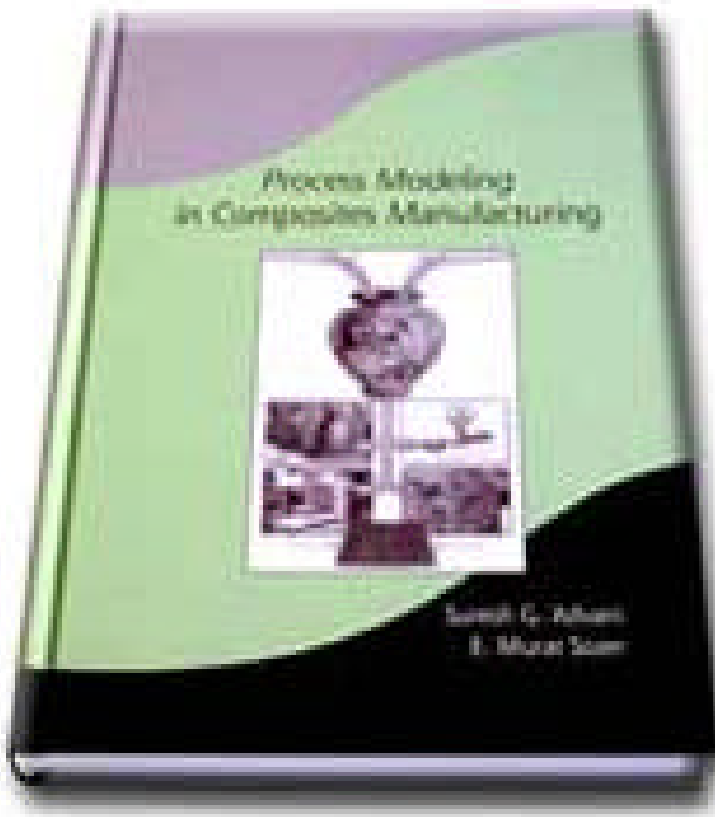

What Are Composites?



Composites are comprised of two or more separate materials that, when combined, lead to improved properties over the individual components.

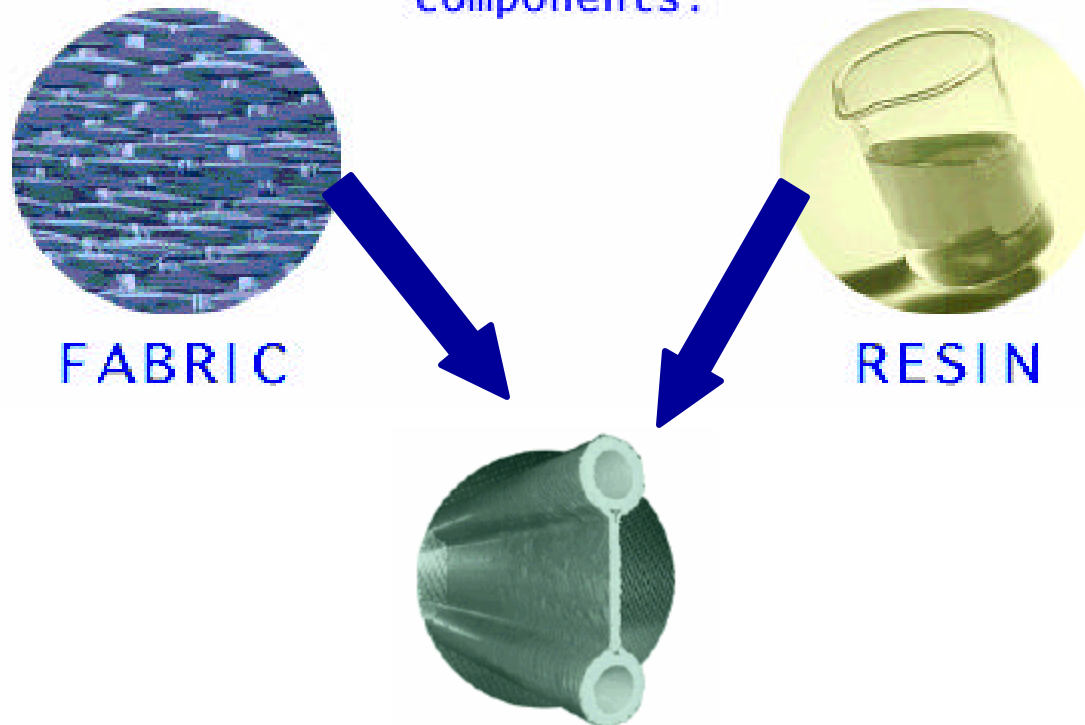

Liquid Composite Molding Processes

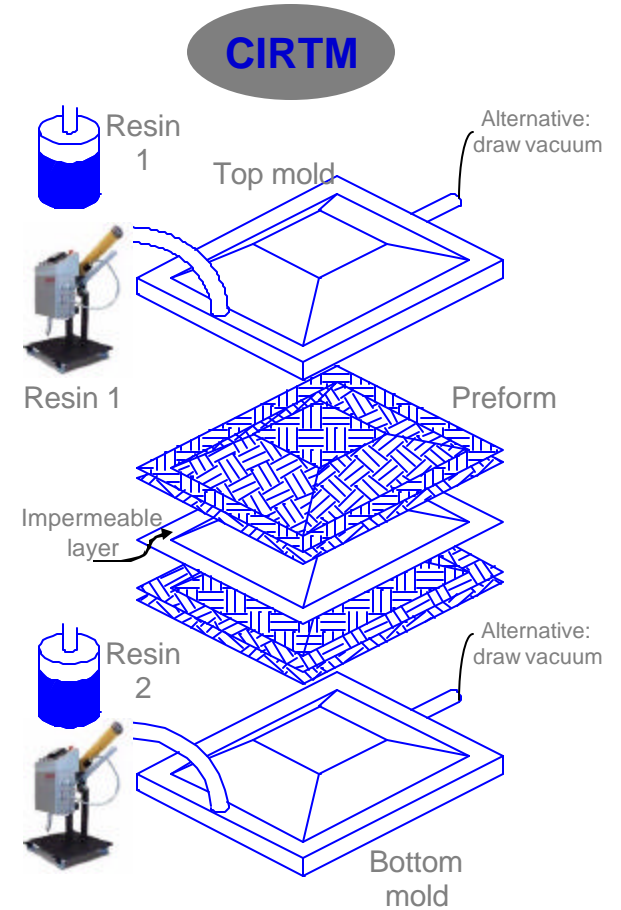
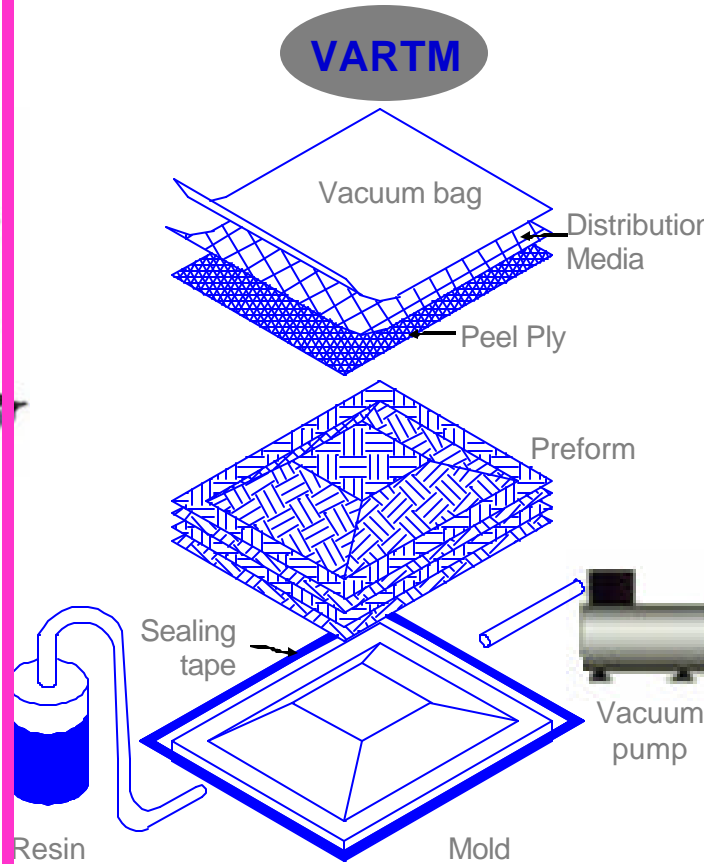
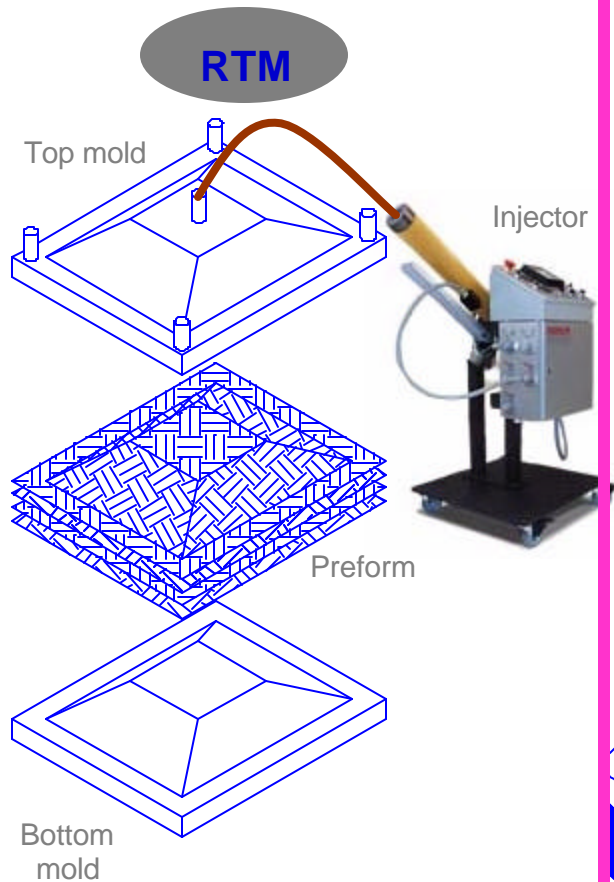

Applications



Automobiles



Infrastructure



Aircraft



Marine Systems



Bicycles



Mass Transit Vehicles



Cargo Containers

Issues and Challenges in Liquid Molding



Issues

- ◆ Complete Saturation and Voids
- ◆ Injection and Vent Locations
- ◆ Process Control
- ◆ Reliability and Repeatability

Challenges

- ◆ Three Dimensional Flow Modeling
- ◆ Saturation Physics
- ◆ Dimensional Tolerances
- ◆ Flow Control
- ◆ Distribution Media Design
- ◆ Location of Resin Injectors
- ◆ Automation
- ◆ Large and Complex Parts



Goal



Develop and Apply Tools in an Intelligent Manner to Advance Manufacturing by Liquid Composite Molding

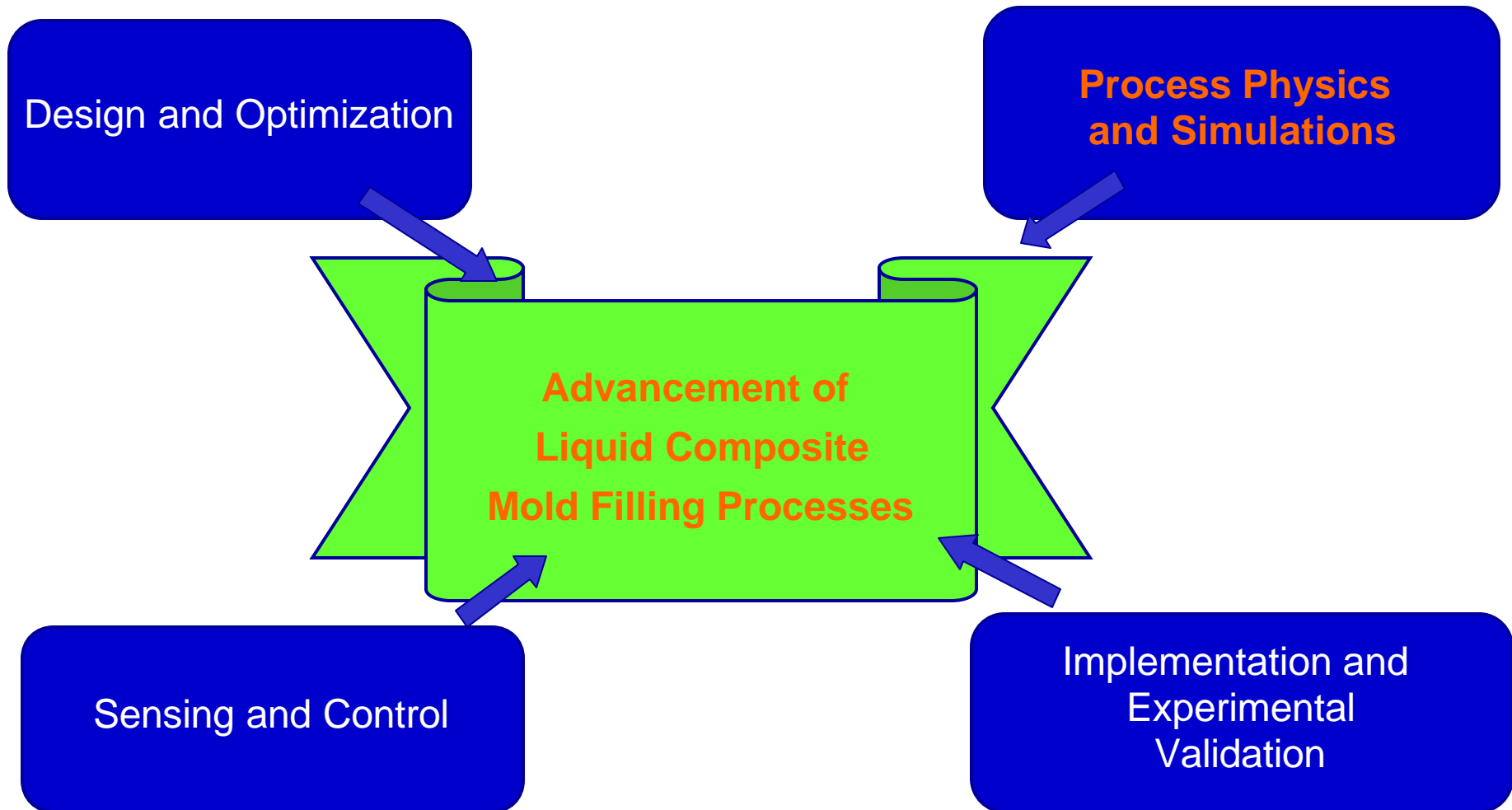

Process Physics and Simulations

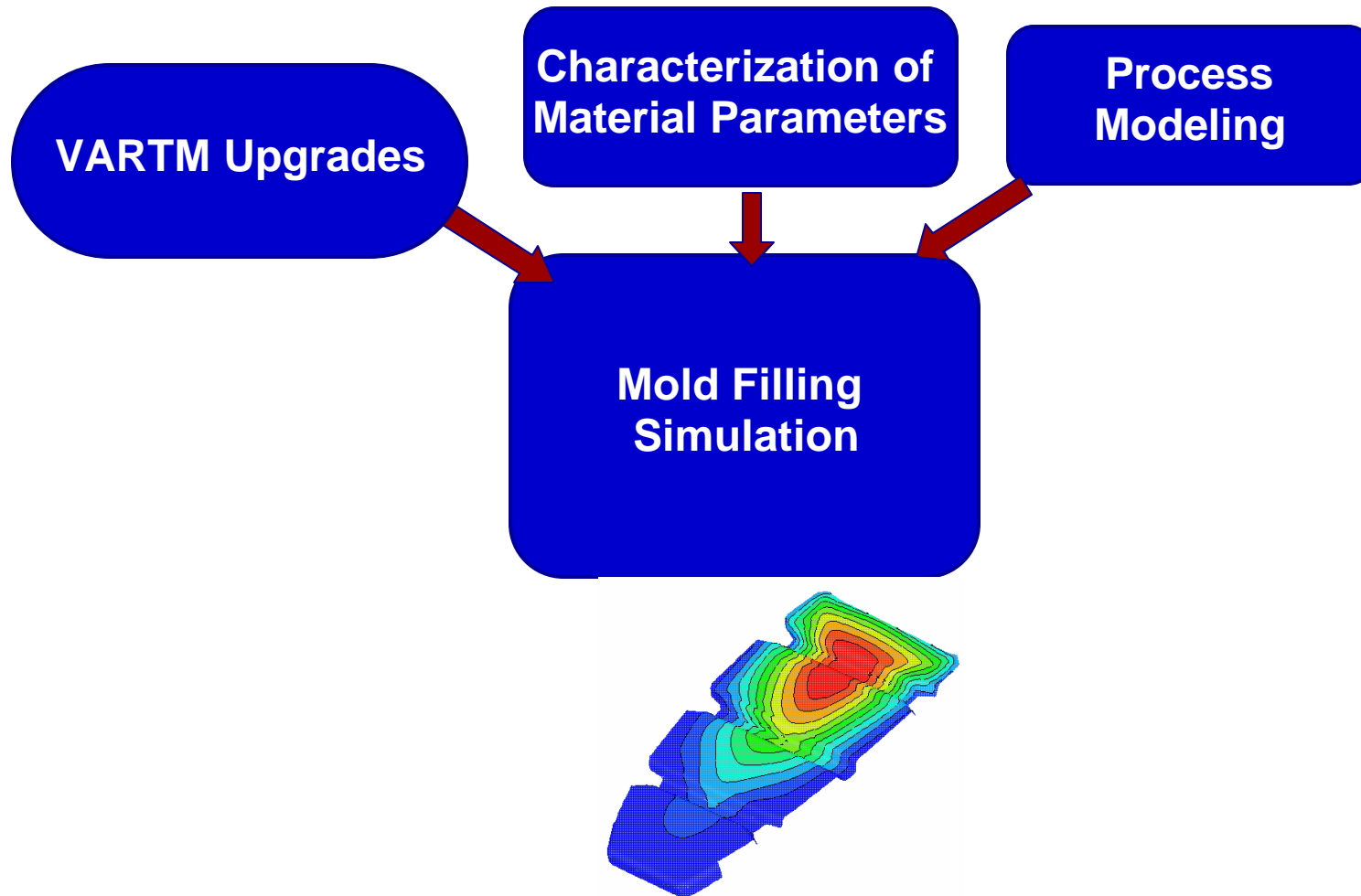

Mold Filling : Need For Simulation

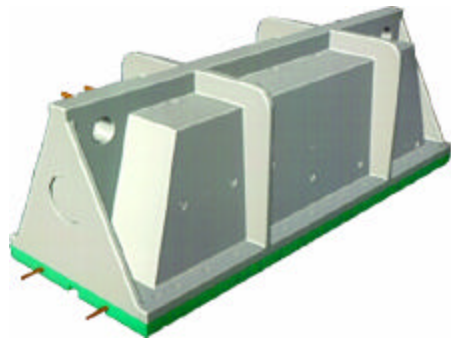

Closed Mold

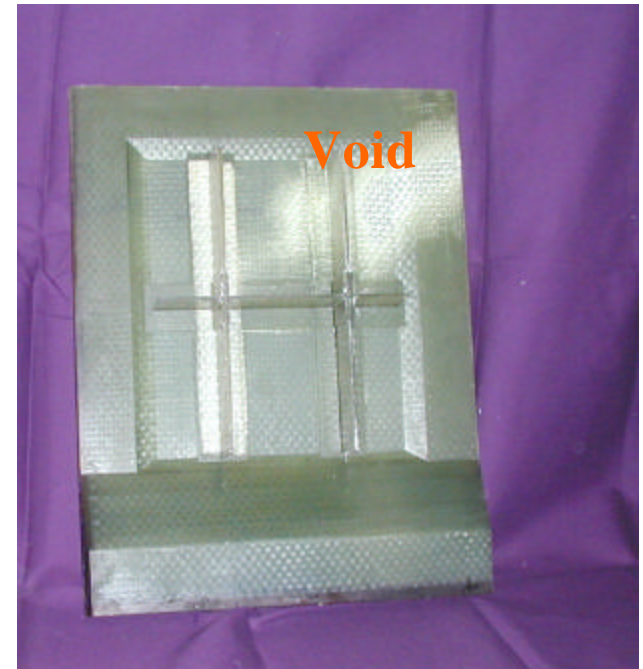
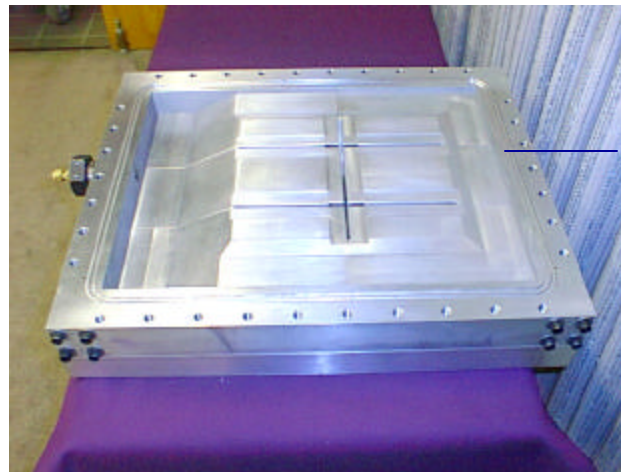
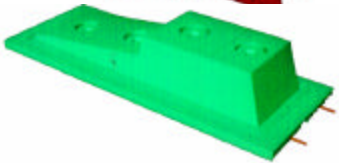
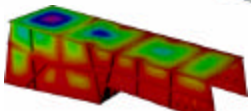
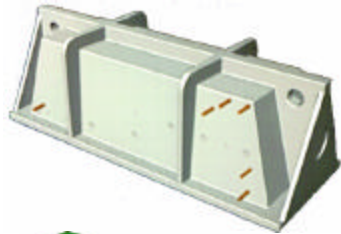

Void Formation in final part

Mold filling simulations are necessary to examine the resin flow in closed molds

Governing Equations for RTM



2-D Darcy's Law velocity-pressure relationship:

$$\begin{pmatrix} \bar{u}_x \\ \bar{u}_y \end{pmatrix} = -\frac{1}{h} \begin{pmatrix} K_{xx} & K_{xy} \\ K_{yx} & K_{yy} \end{pmatrix} \begin{pmatrix} \frac{\partial P}{\partial x} \\ \frac{\partial P}{\partial y} \end{pmatrix}$$

$$\frac{\partial}{\partial x} \left(\frac{K_{xx}}{h} \frac{\partial P}{\partial x} \right) + \frac{\partial}{\partial x} \left(\frac{K_{xy}}{h} \frac{\partial P}{\partial y} \right) + \frac{\partial}{\partial y} \left(\frac{K_{yx}}{h} \frac{\partial P}{\partial x} \right) + \frac{\partial}{\partial y} \left(\frac{K_{yy}}{h} \frac{\partial P}{\partial y} \right) = 0$$

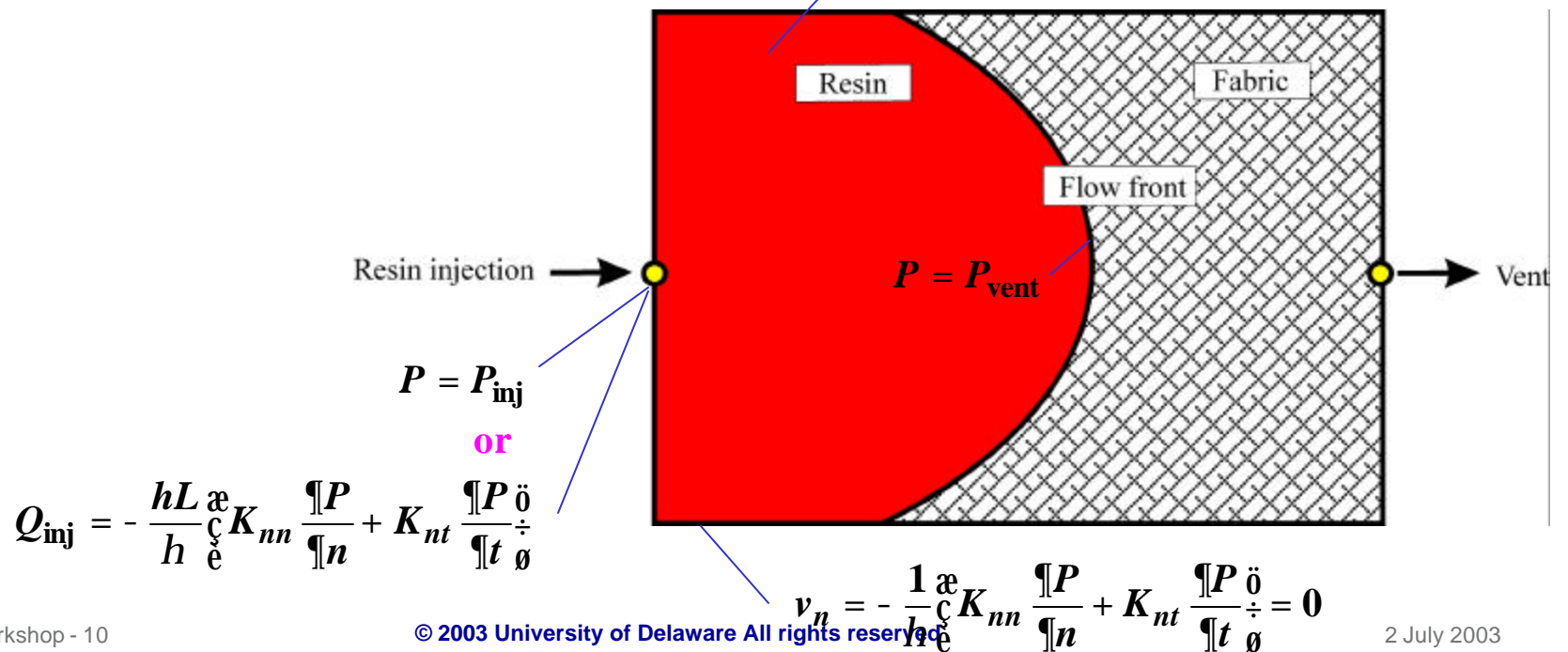

3D Flow in VARTM

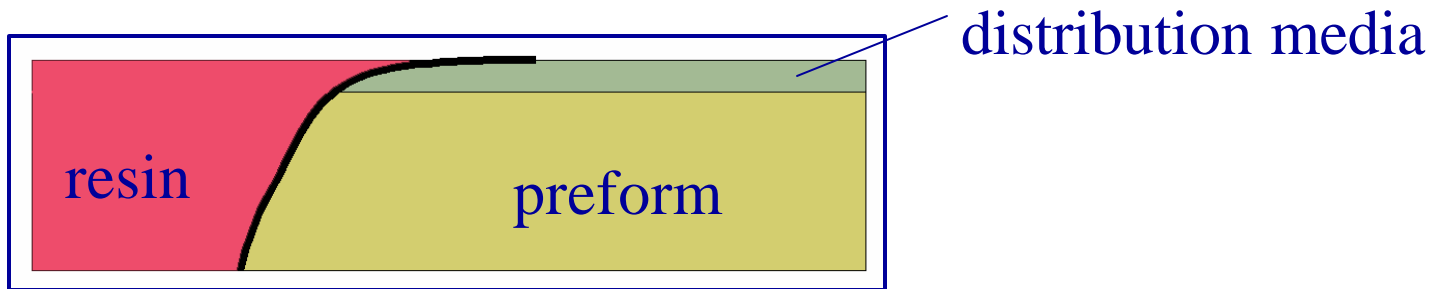
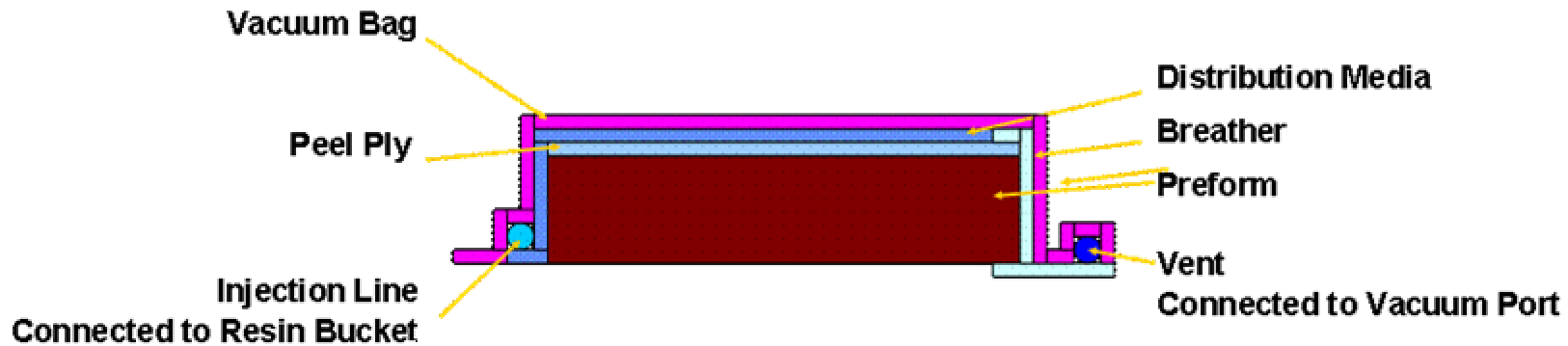

3-D Darcy's Law velocity-pressure relationship:

$$\begin{Bmatrix} \bar{u}_x \\ \bar{u}_y \\ \bar{u}_z \end{Bmatrix} = -\frac{1}{h} \begin{bmatrix} K_{xx} & K_{xy} & K_{xz} \\ K_{yx} & K_{yy} & K_{yz} \\ K_{zx} & K_{zy} & K_{zz} \end{bmatrix} \begin{Bmatrix} \partial P / \partial x \\ \partial P / \partial y \\ \partial P / \partial z \end{Bmatrix}$$

Finite Element Method for the Solution of Resin Pressure



$$P^e = \sum_{i=1}^n N_i P_i \quad [[S^e]] [P] = [Q] \quad Q_{bc}$$

$$S_{ij}^e = \int_{\text{we}} \frac{\partial \epsilon}{\partial \xi} \frac{\partial \xi}{\partial x} \frac{\partial \xi}{\partial y} \left[\frac{K_{xx}}{h} \frac{N_j}{\xi x} \frac{N_i}{\xi x} + \frac{K_{yy}}{h} \frac{N_j}{\xi y} \frac{N_i}{\xi y} + \frac{K_{xy}}{h} \frac{N_j}{\xi x} \frac{N_i}{\xi y} + \frac{K_{xy}}{h} \frac{N_j}{\xi y} \frac{N_i}{\xi x} \right] dW$$

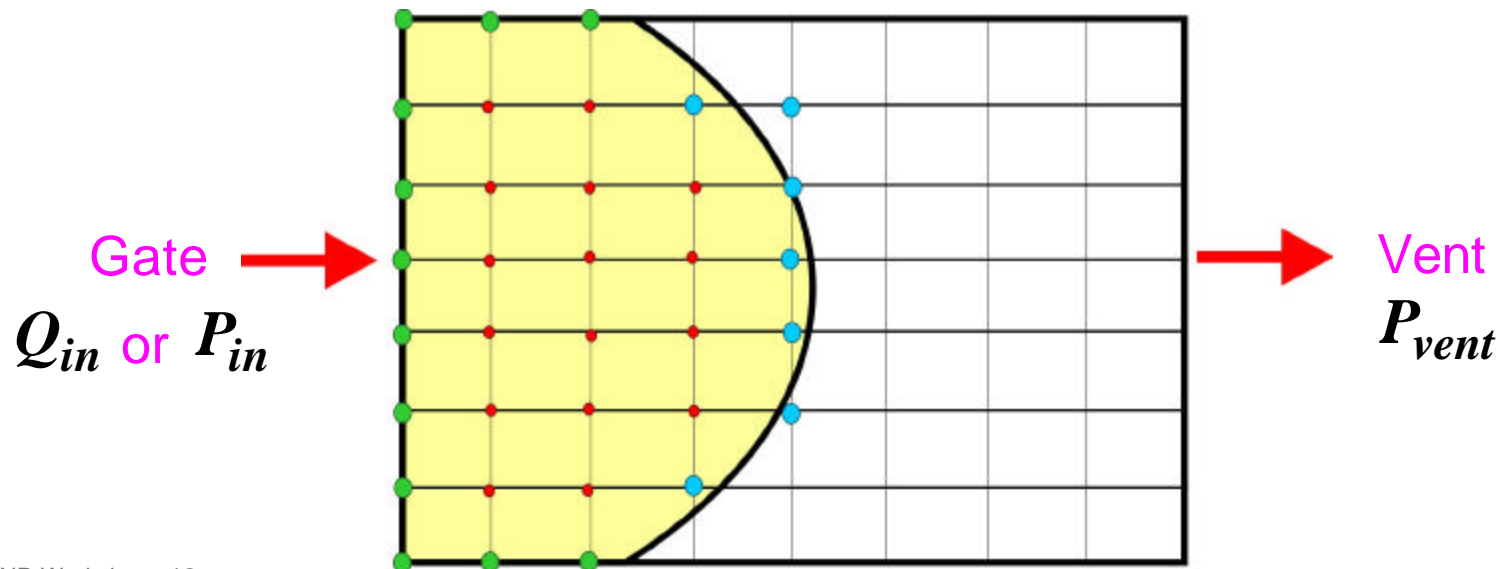

Control Volume Approach for the Advancement of the Flow Front

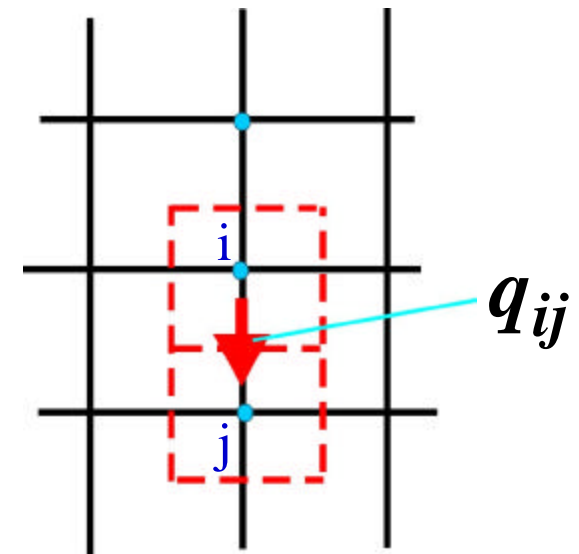
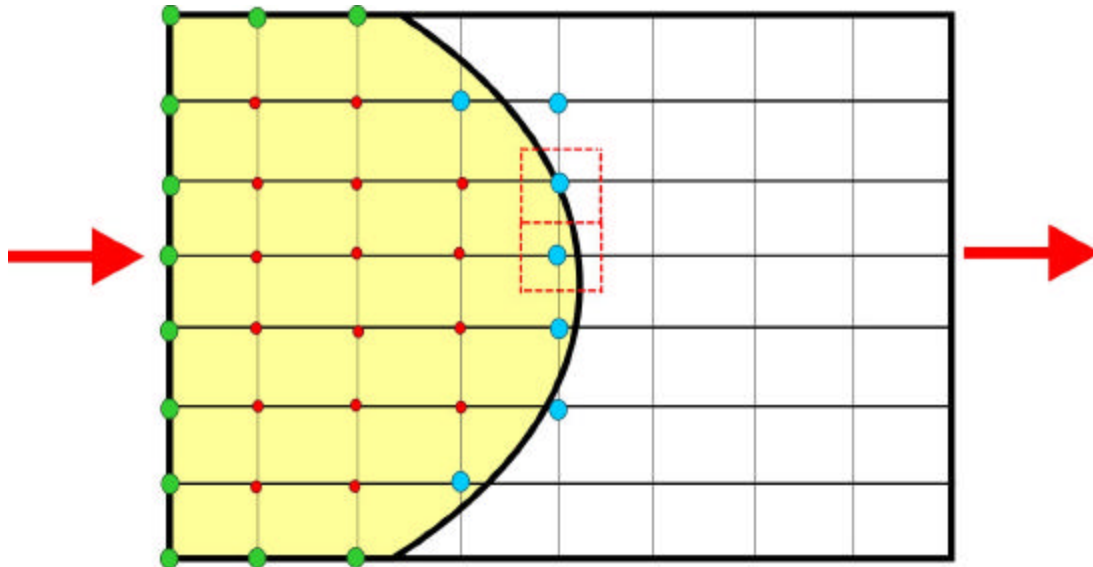

$$Q_i = \sum_{j=1}^n \dot{a} q_{ij} Dt$$

Permeability Measurements for RTM

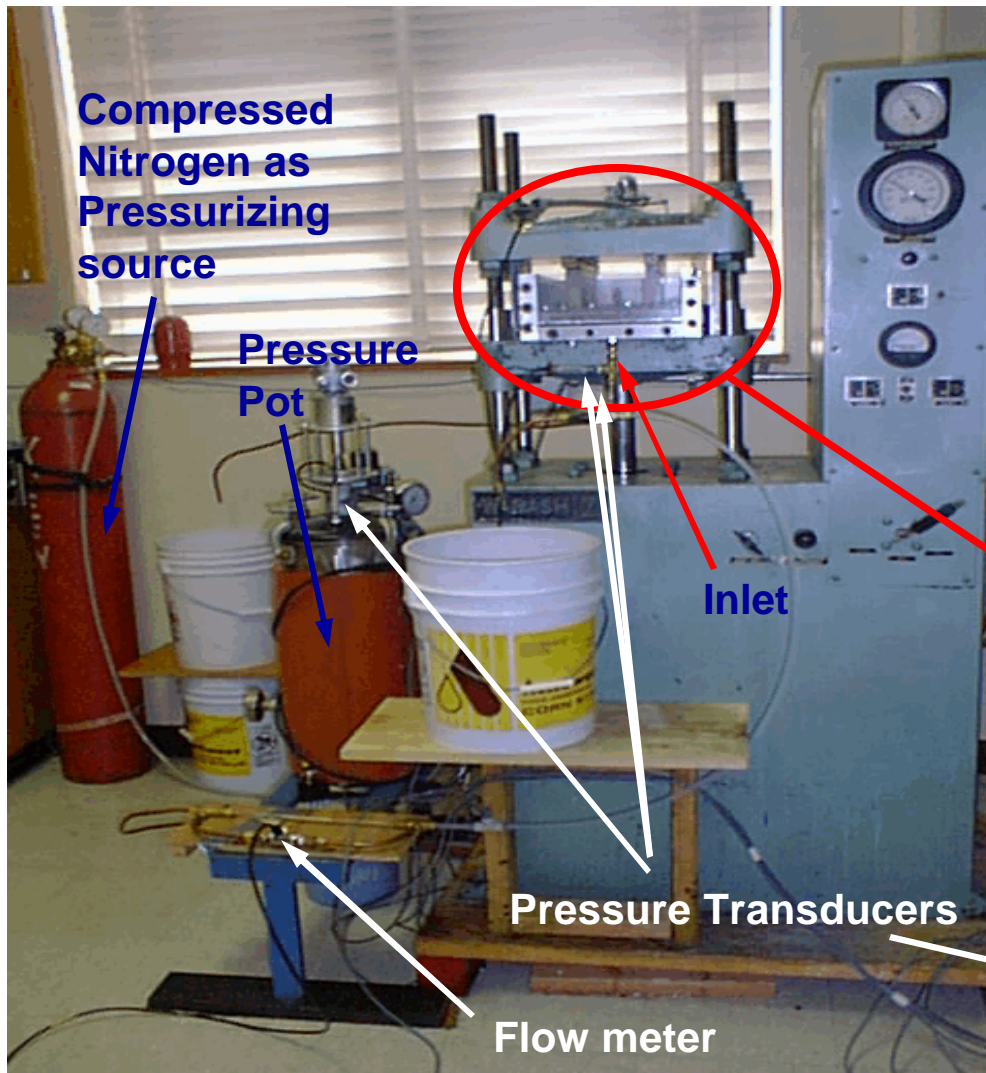

Detailed measurements of permeability vs. V_f by changing the compaction load

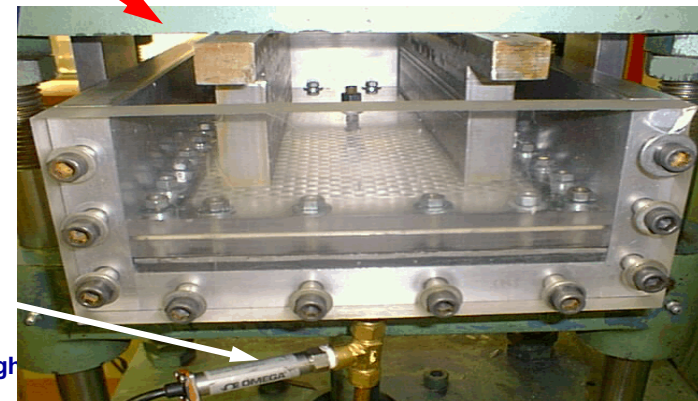
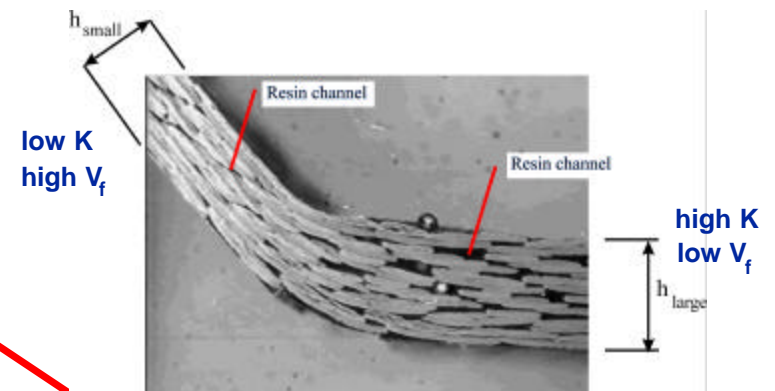

All right

003

Permeability as a Function of Fiber Volume Fraction



Fabric = Vetrotex 324, 14 layer.

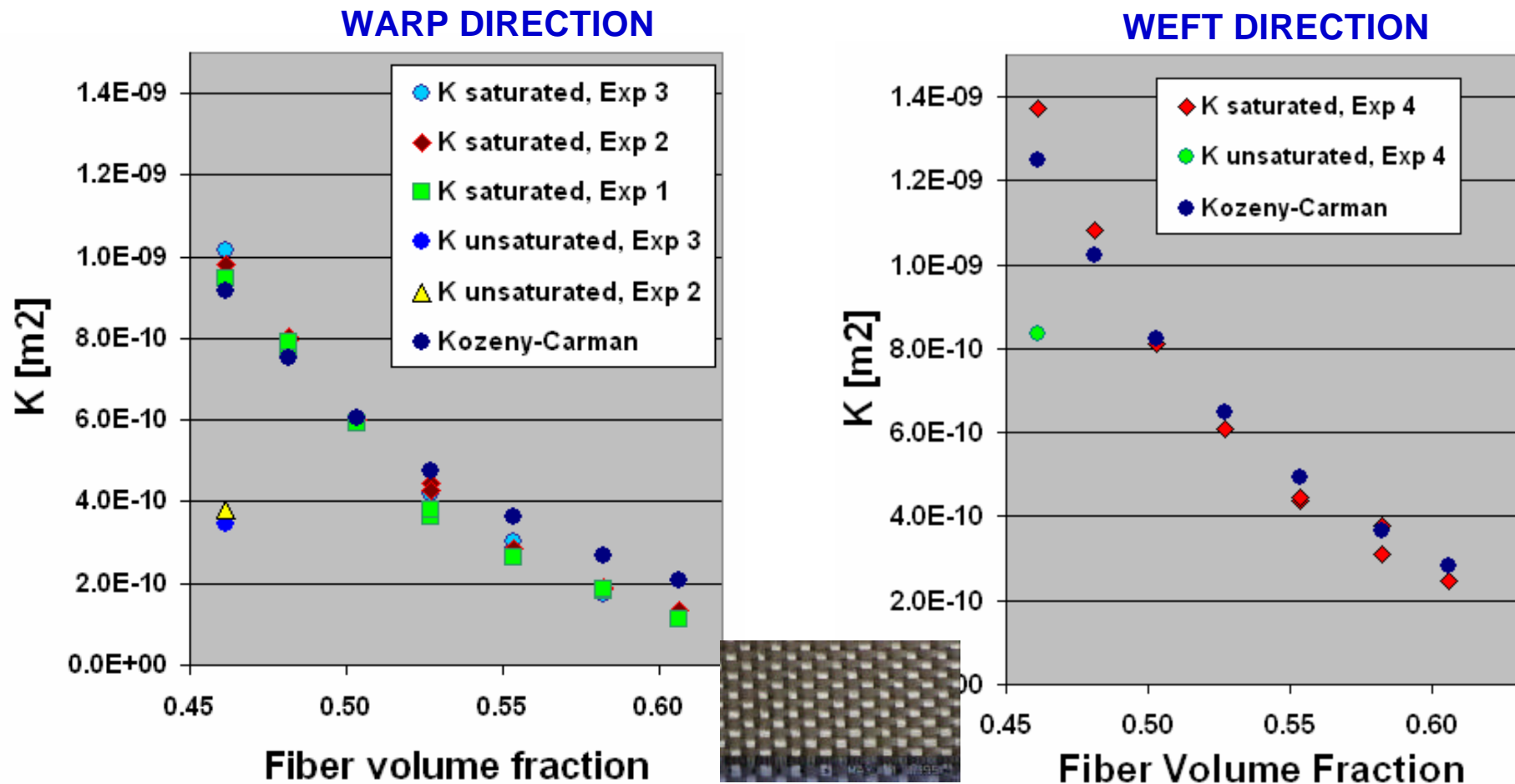

PERMSTAT Permeability Measurement Station for VARTM Process

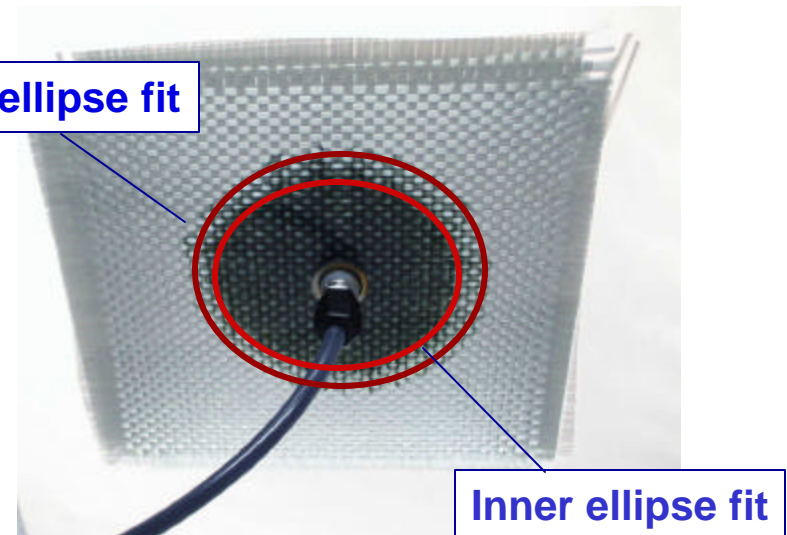
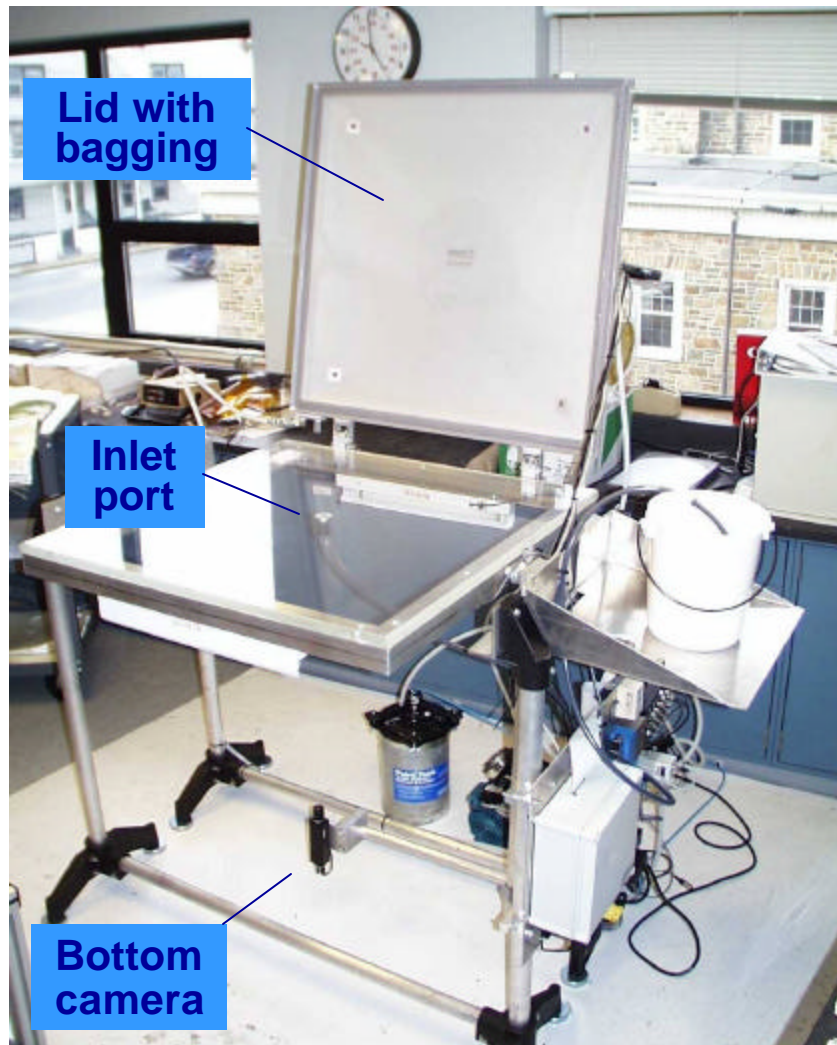

Top: Bottom view of point injection into dry preform, with blackened corn syrup

Left: PERMSTAT set-up

PERMSTAT Schematic

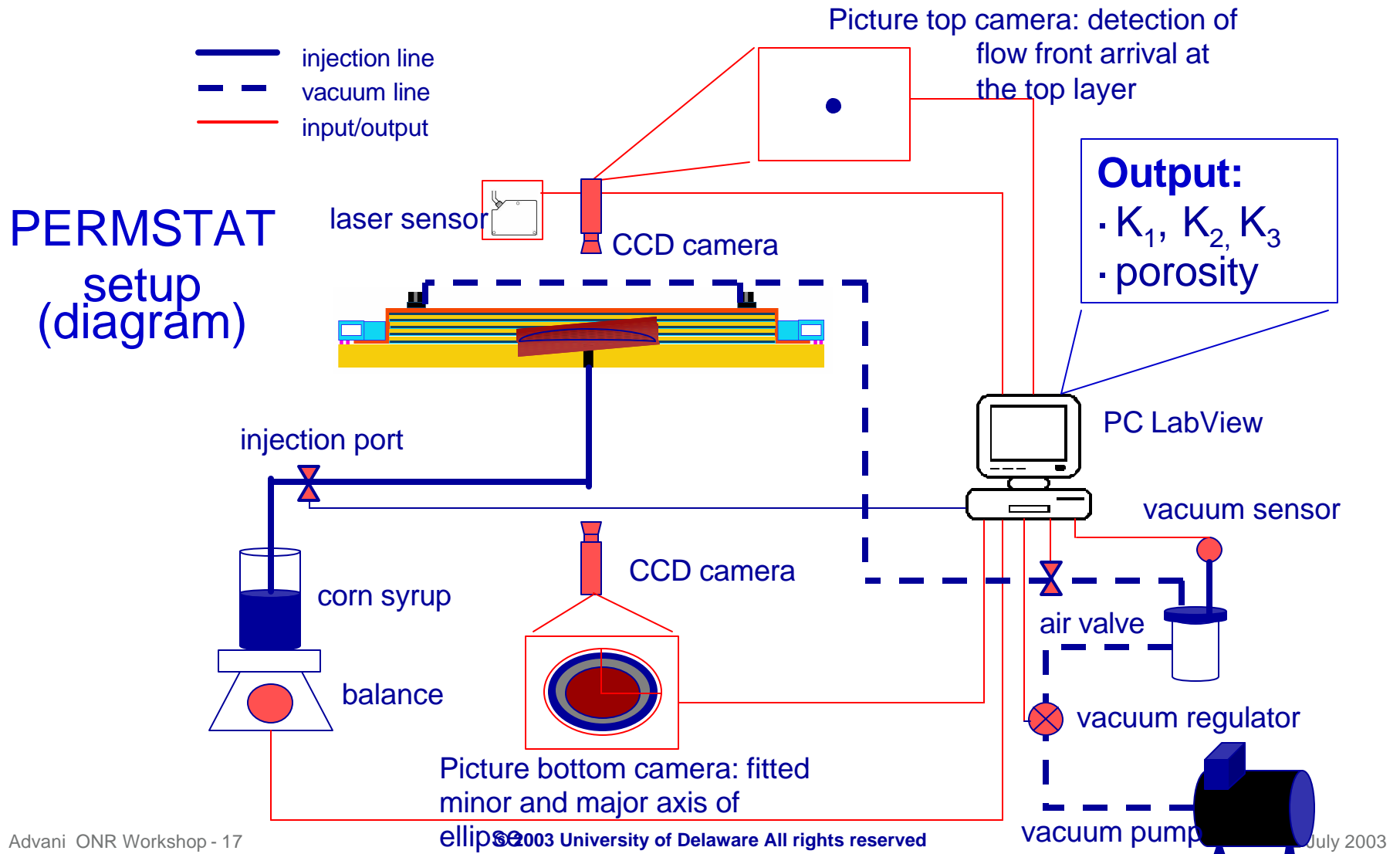

3-D Permeability Estimation Approach



Mass of the liquid that is in the perform and the injection tube (not required)

Coordinates of the flow front position on the principal axes, i.e the major axes of the ellipse.

Time elapsed from the start of injection

PERMEABILITY TENSOR

$$K_{xx}, K_{yy}, K_{zz}$$

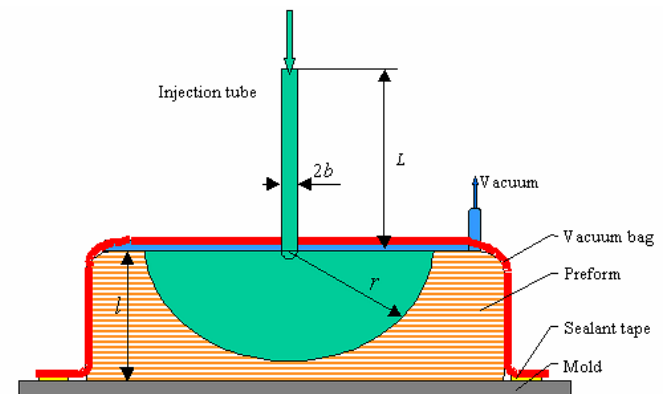
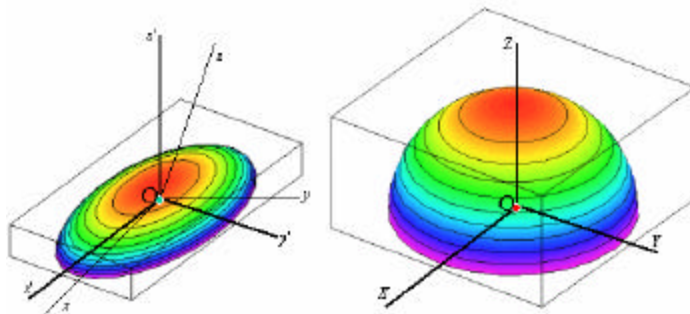

Principal Permeability Values for Typical Preforms



Breather:
Airtech Airweave
N10 400g/m²



Random mat:
Vetrotex Unifilio
816 450g/m²



Non crimp :
320g/m²

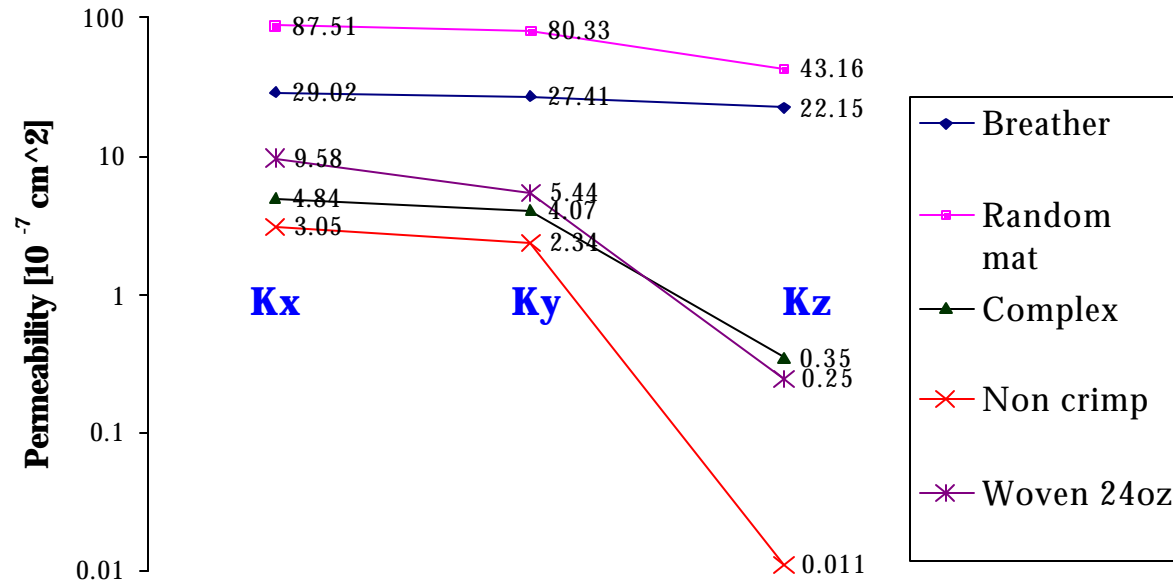
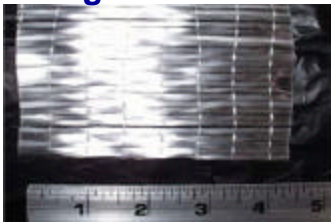

Complex:
Vetrotex
Stitchment
2400g/m²

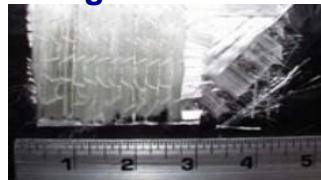

Woven:
Boeing 300g/m²

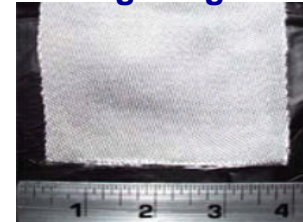

Woven:
Vetrotex 324
800g/m²

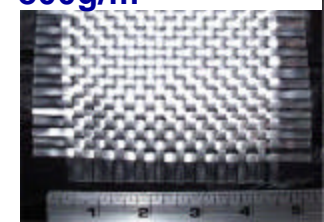

Principal Direction and Vf Change for Double Curvatures in Part Geometry

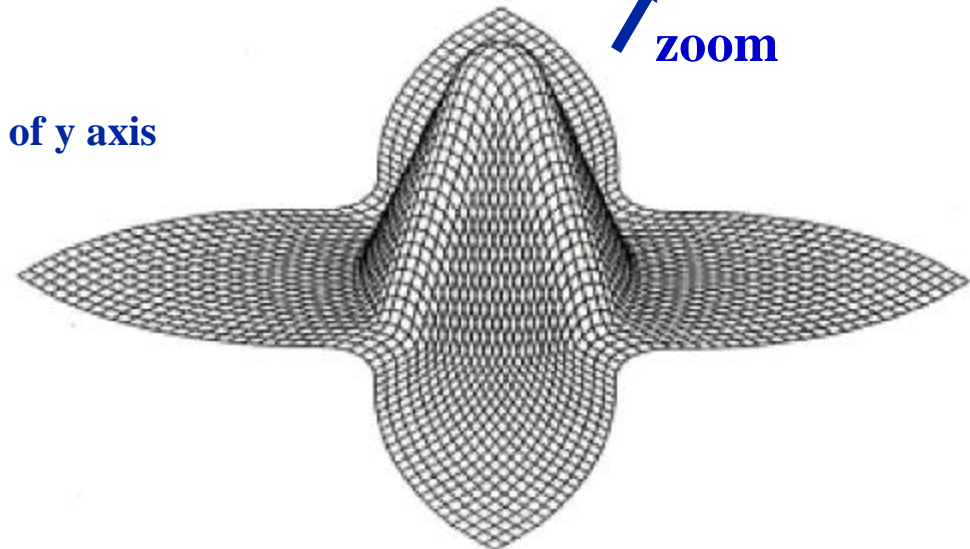
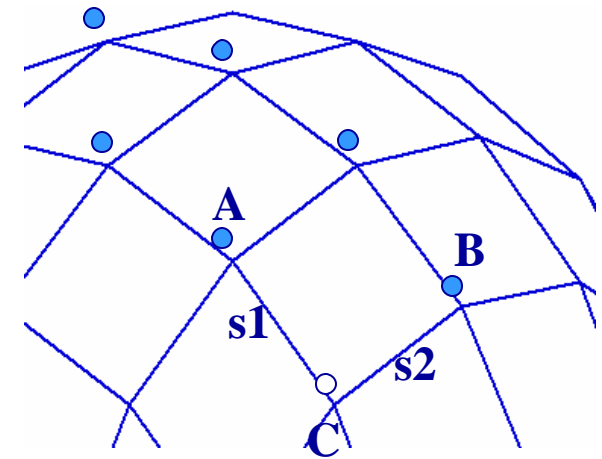
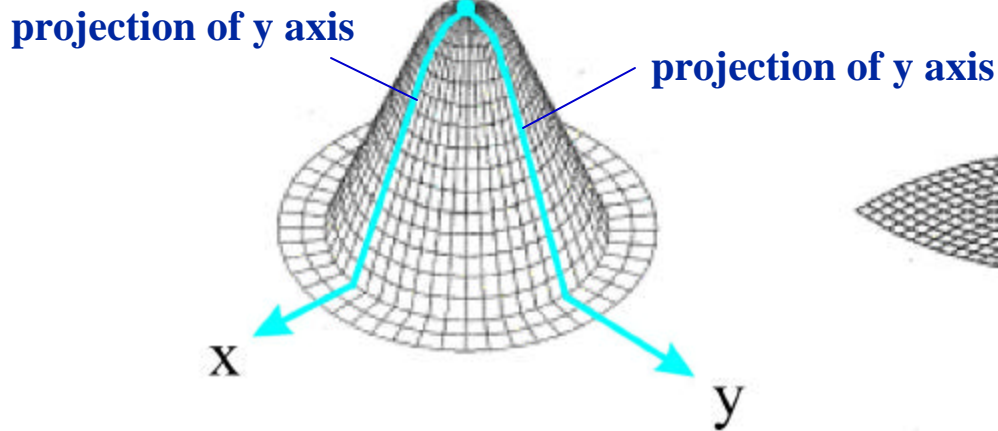
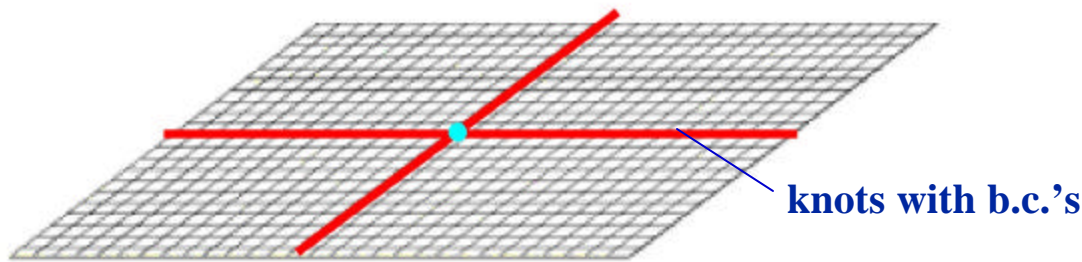

Permeability Model for Woven Fabrics

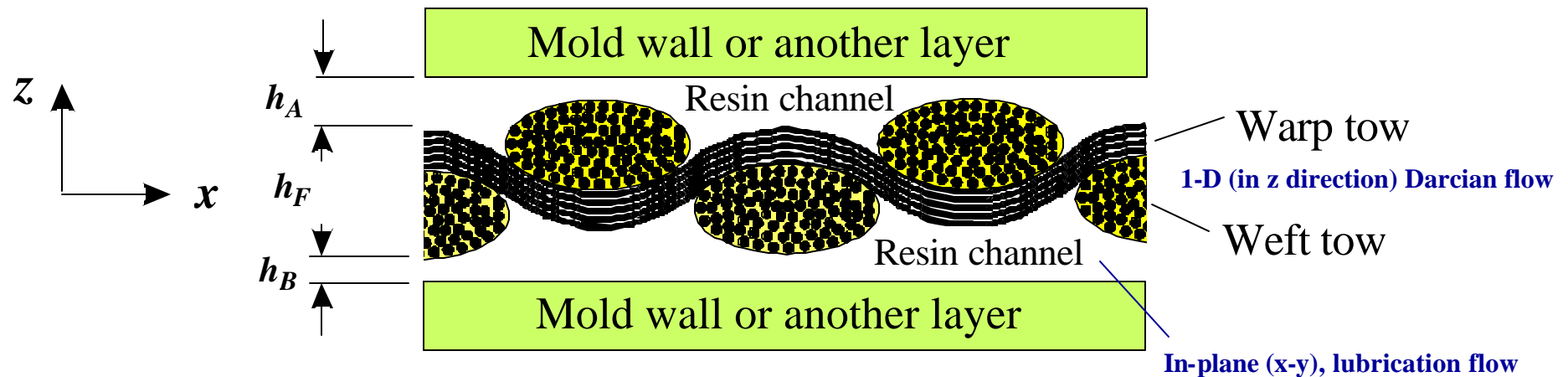

$$-\frac{K_{zz}(p^B - p^A)}{hh^F} - \frac{1}{6h} \left(\frac{\partial((h^A)^3 \partial p^A / \partial x)}{\partial x} + \frac{\partial((h^A)^3 \partial p^A / \partial y)}{\partial y} \right) = 0$$

$$\frac{K_{zz}(p^B - p^A)}{hh^F} - \frac{1}{6h} \left(\frac{\partial((h^B)^3 \partial p^B / \partial x)}{\partial x} + \frac{\partial((h^B)^3 \partial p^B / \partial y)}{\partial y} \right) = 0$$

Input to model: geometry: $h_A(x, y), h_F(x, y), h_B(x, y)$

Output: K_{xx}, K_{yy}, K_{xy}

transverse permeability: K_{zz}

Modeling Flowchart

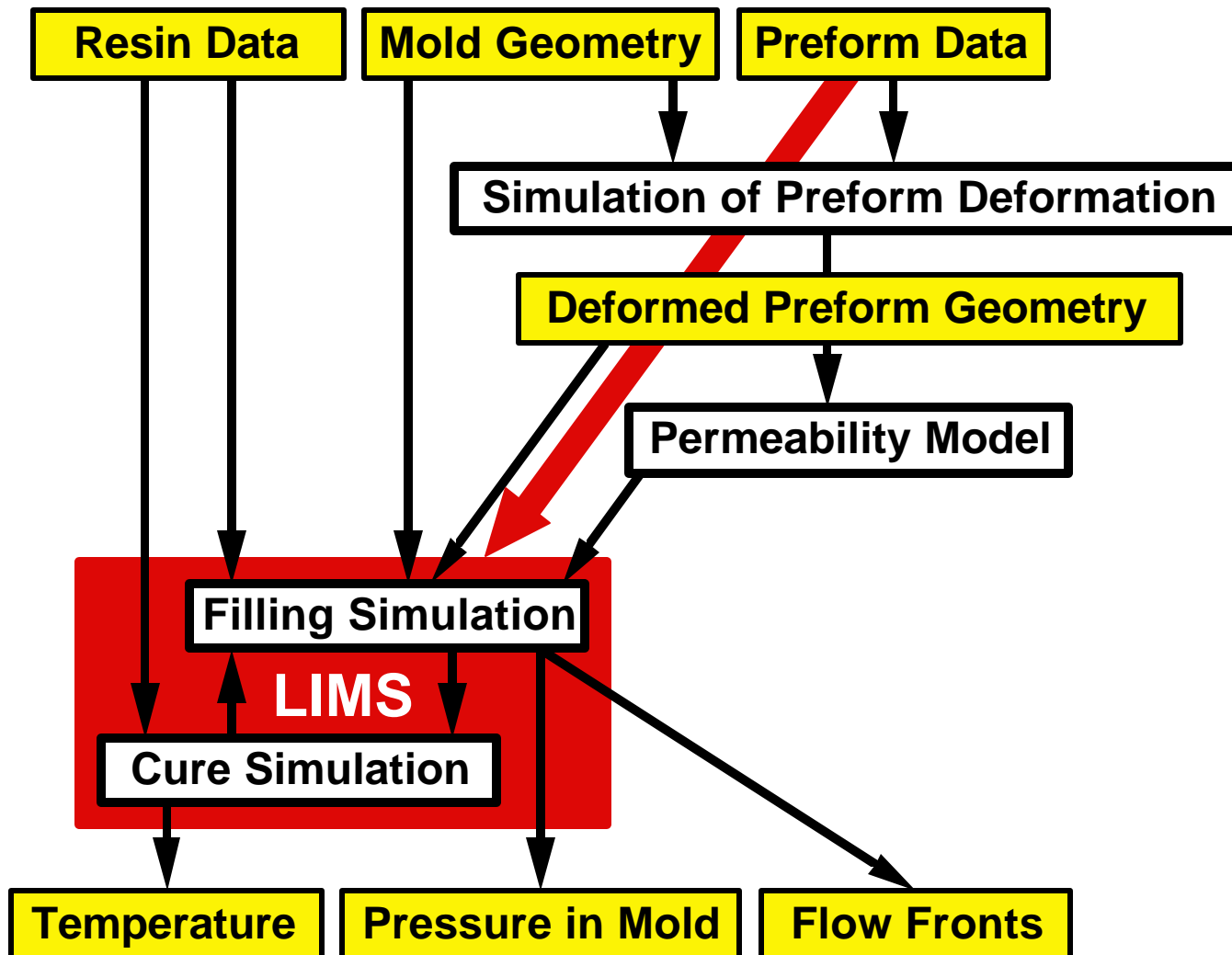

Liquid Injection Molding Simulation



- Finite Element / Control Volume solver
- Optimized algorithms result in very fast computational time
- Use of 1-D, 2-D and 3-D elements

1- Mesh Generation
in IDEAS, etc.

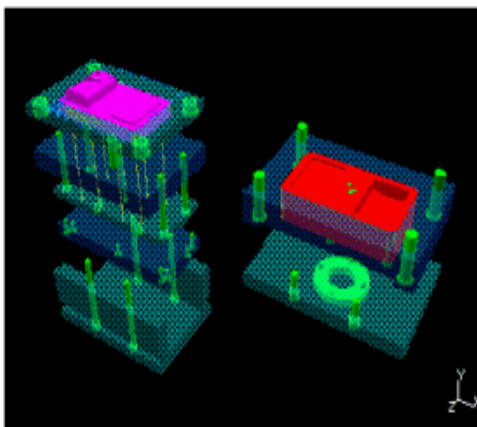

2- Material Properties,
simulation interface

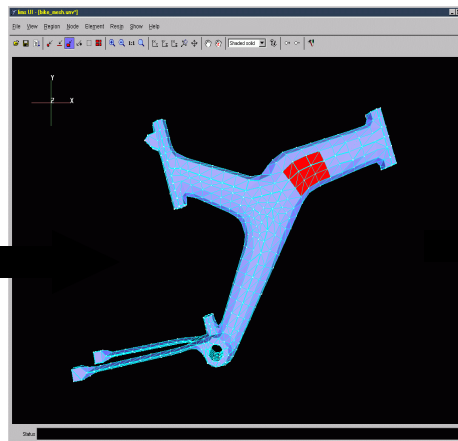

3- Results

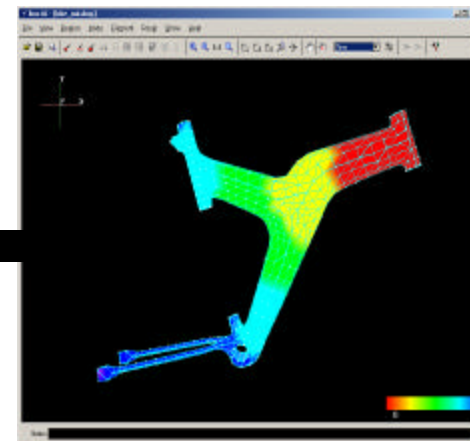

Mold Filling Simulations for 2-D/3-D “Shell” Geometries

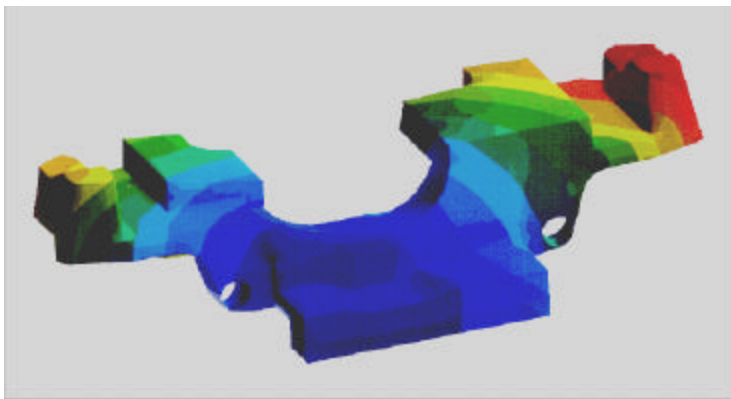

Cross-member of a passenger van

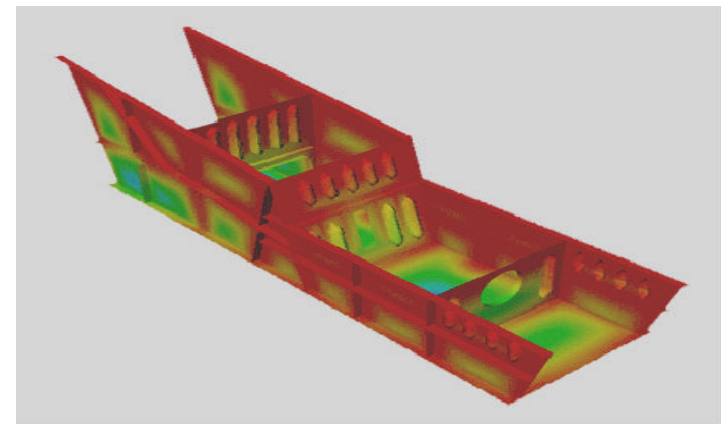

Comanche Helicopter : Keel Beam

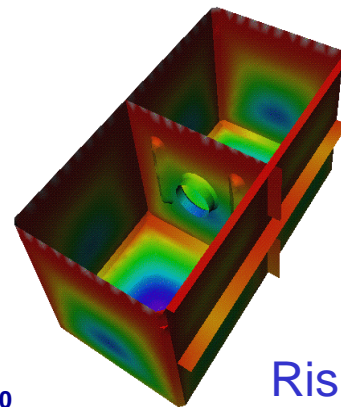

Risk Reduction Box

Influence of Draping

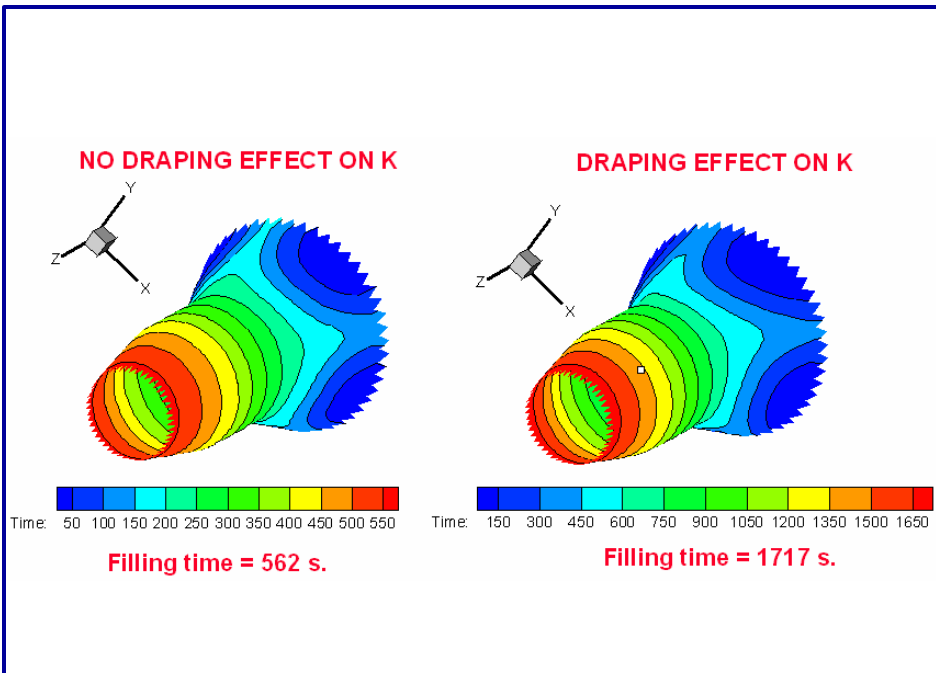
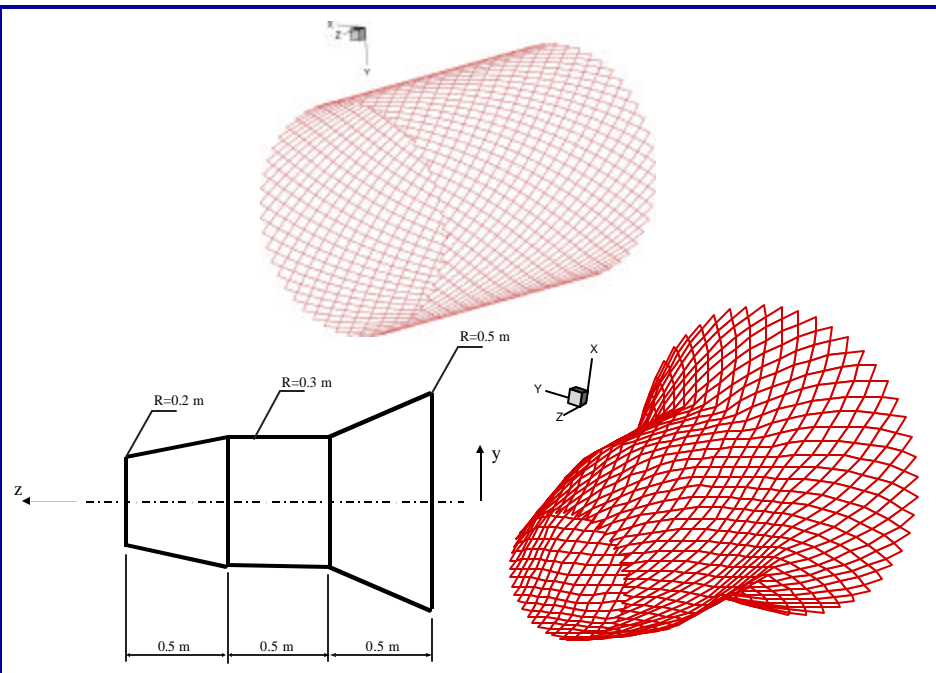
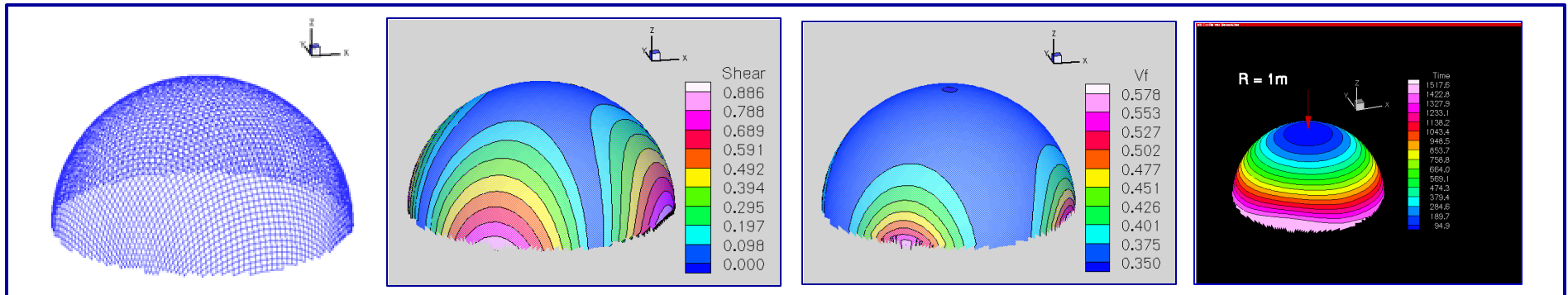

Mold Filling Simulation of Keel Beam Showing Time History of Resin Flow

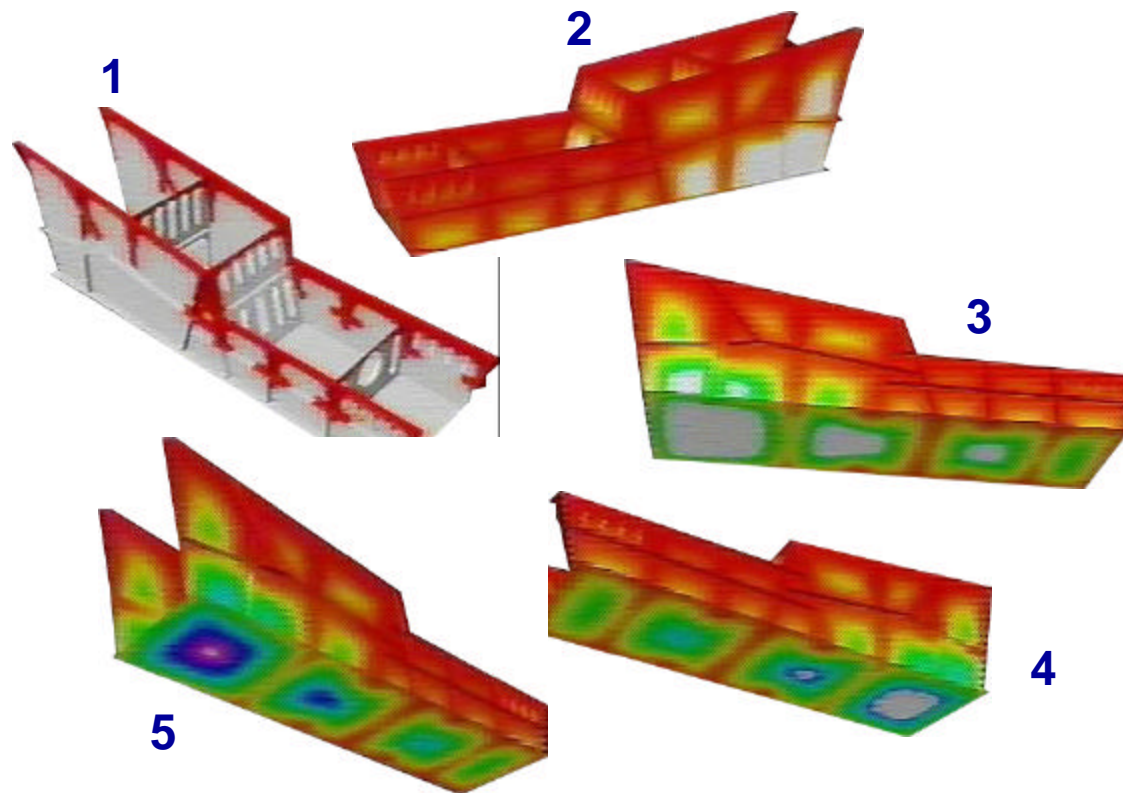

Modeling issues specific to VARTM process

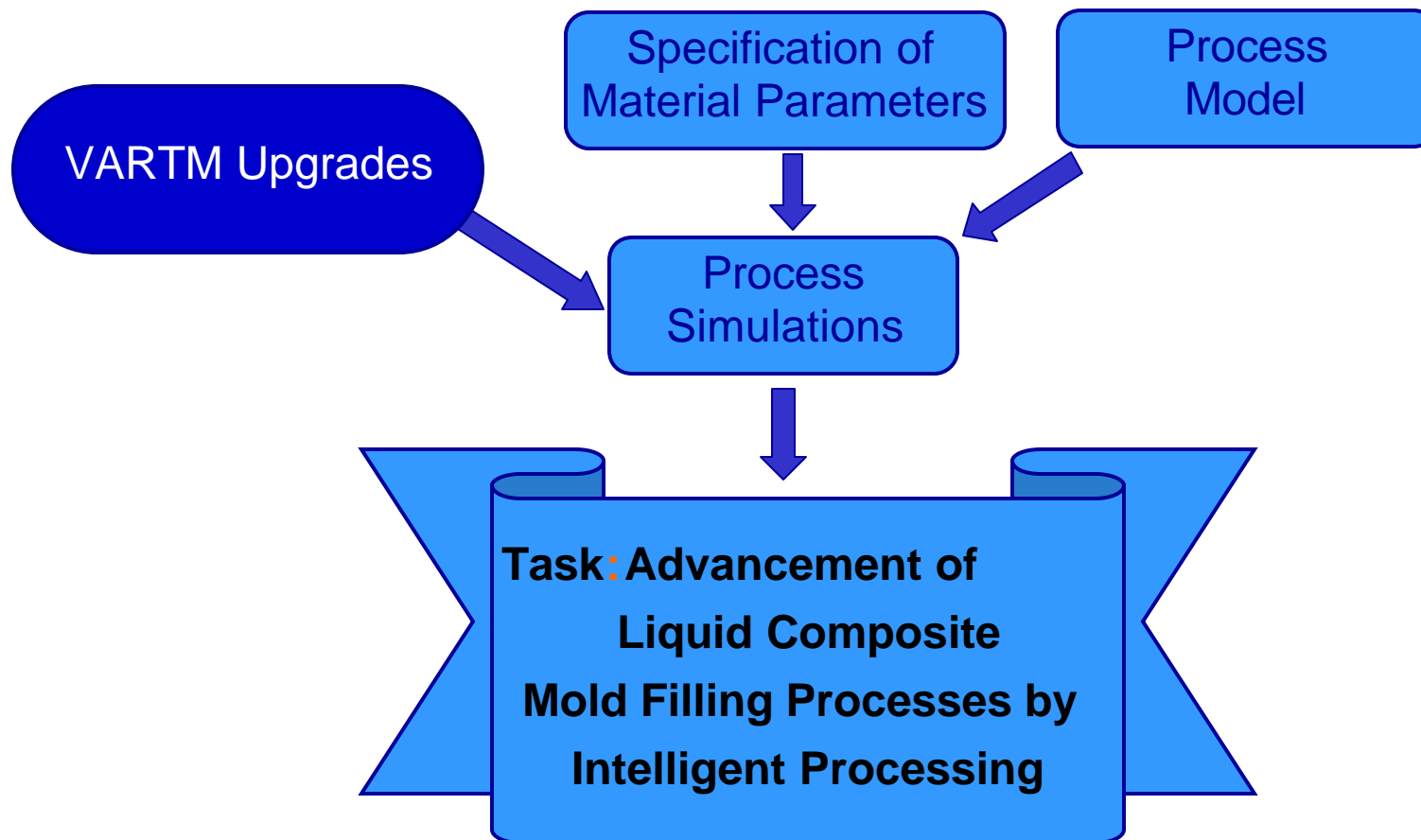

Modeling VARTM in Simulations



Tow Saturation

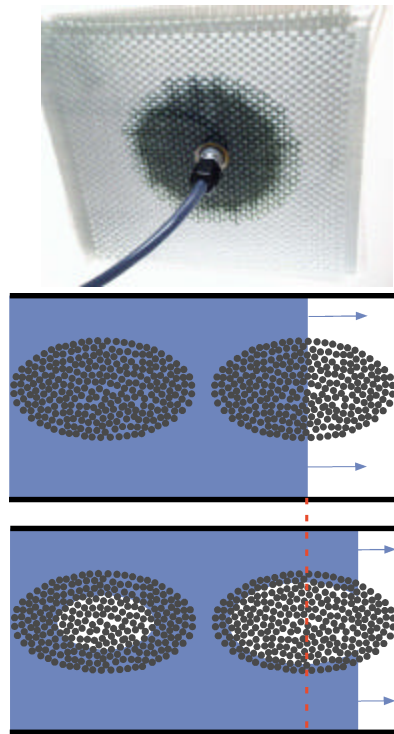

$$\nabla \left(\frac{\mathbf{K}}{h} \nabla p \right) = q(p, s)$$

Advani ONR Workshop - 28

Compaction

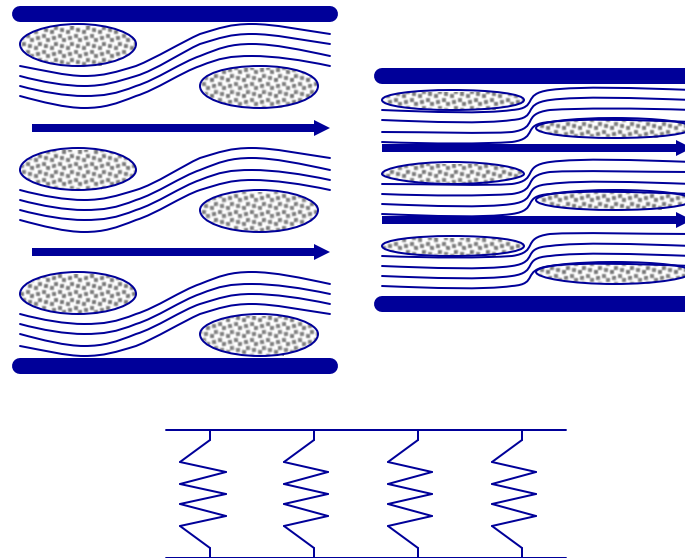

$$P_{atm} - P = A s \frac{\left(\sqrt{\frac{v_f}{v_o}} - 1 \right)^4}{\left(\sqrt{\frac{v_a}{v_f}} - 1 \right)^4}$$

© 2003 University of Delaware All rights reserved

Distribution Media

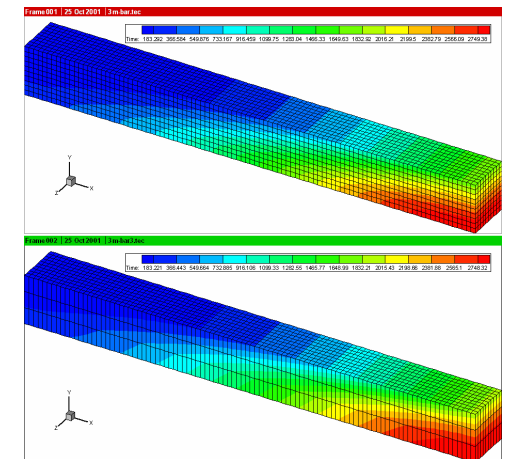

1D distribution media model

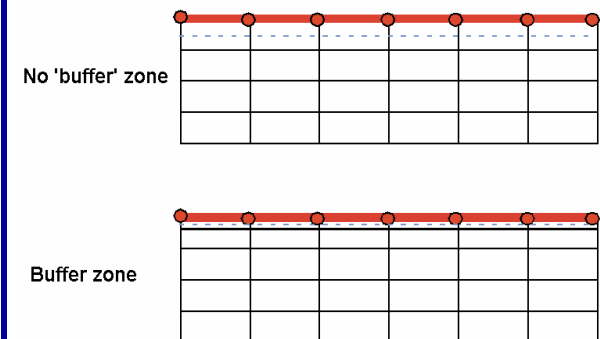

2 July 2003

Fluid Impregnation in Fiber Tows

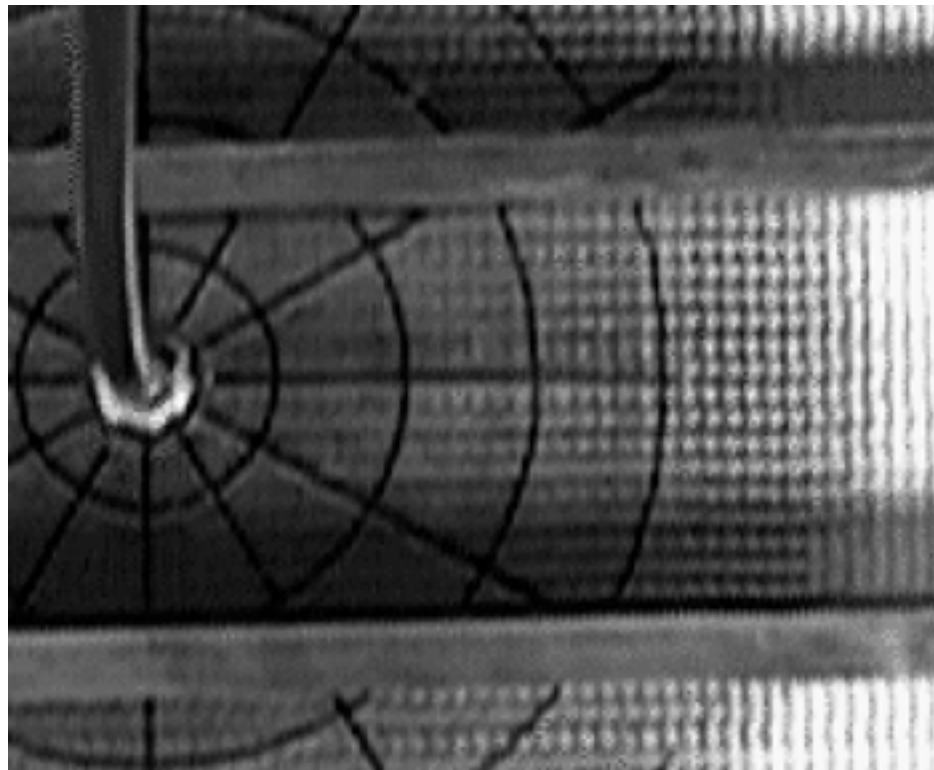

Dual Scale Porous Media



1.

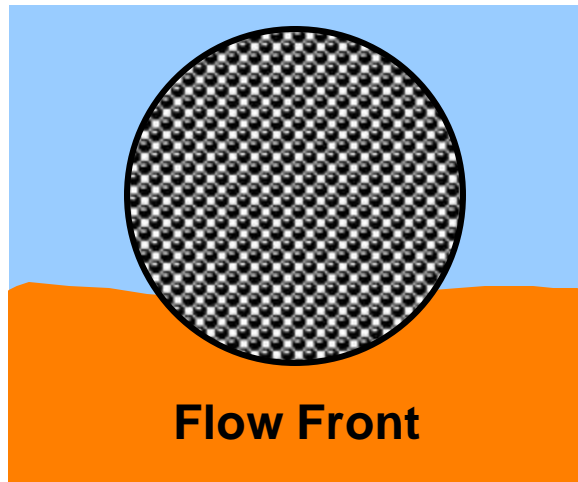

2.

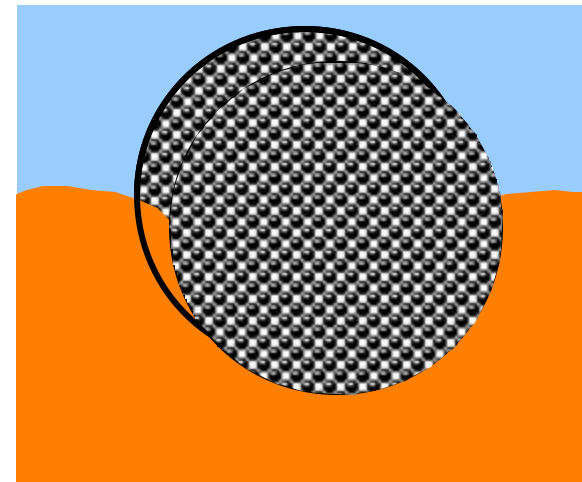

3.

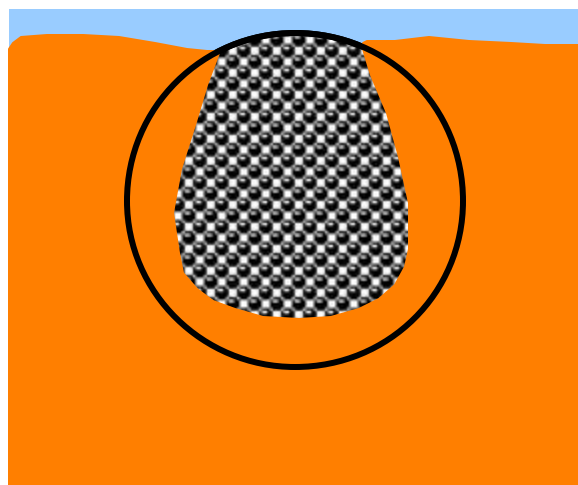

4.

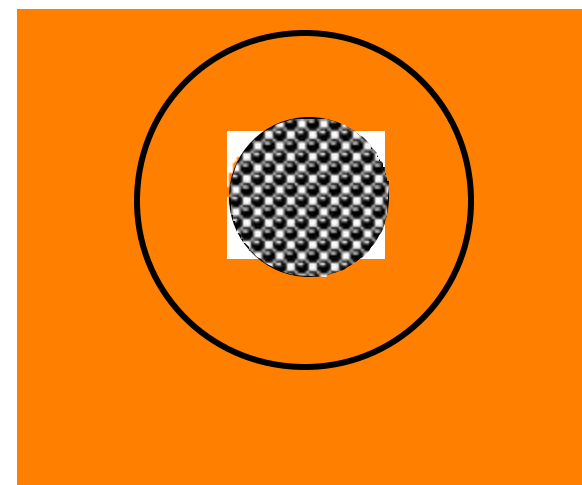

Saturation Modeling In LIMS : Mesh Modification

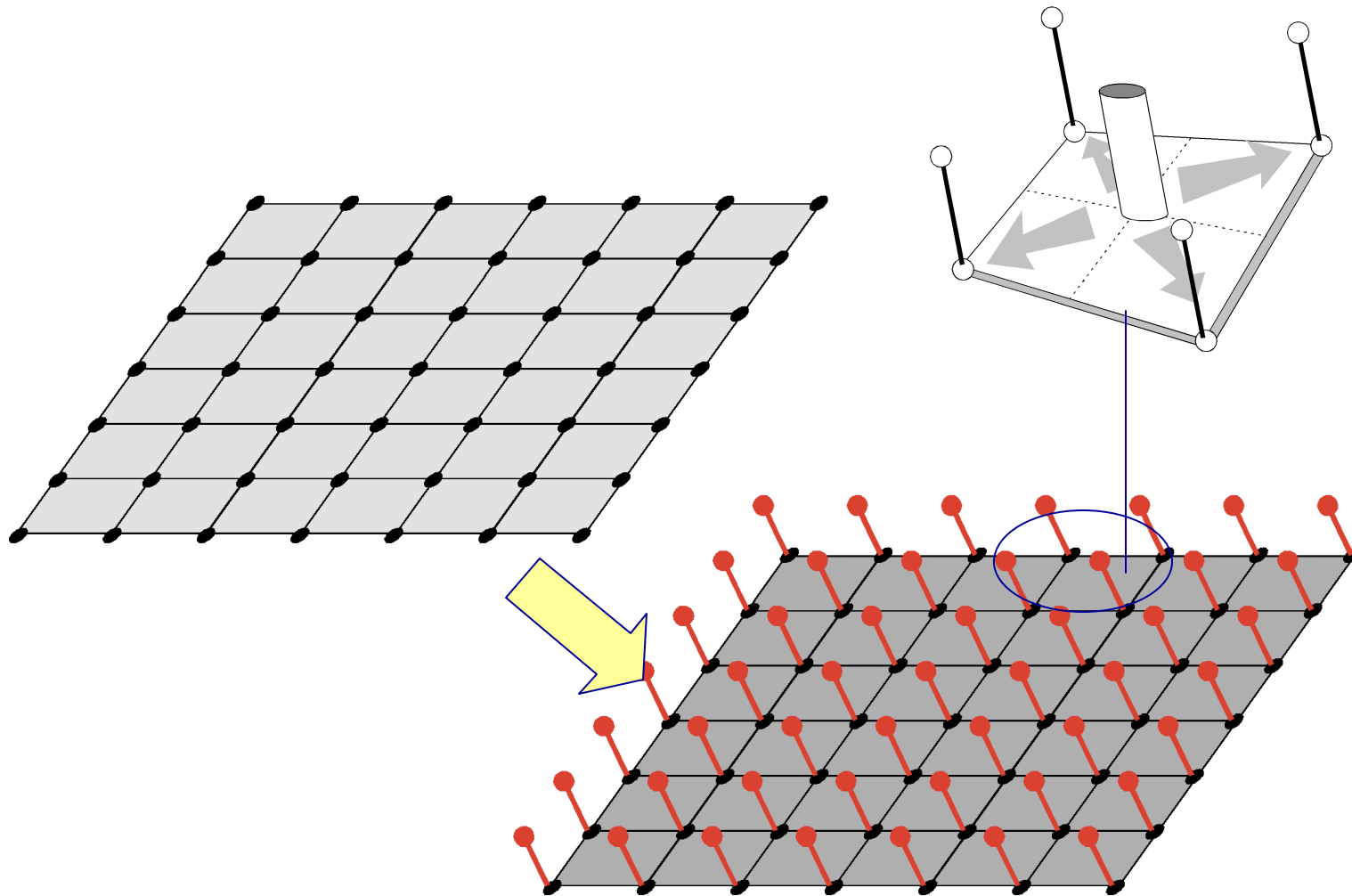

Simulation of Saturation Effect

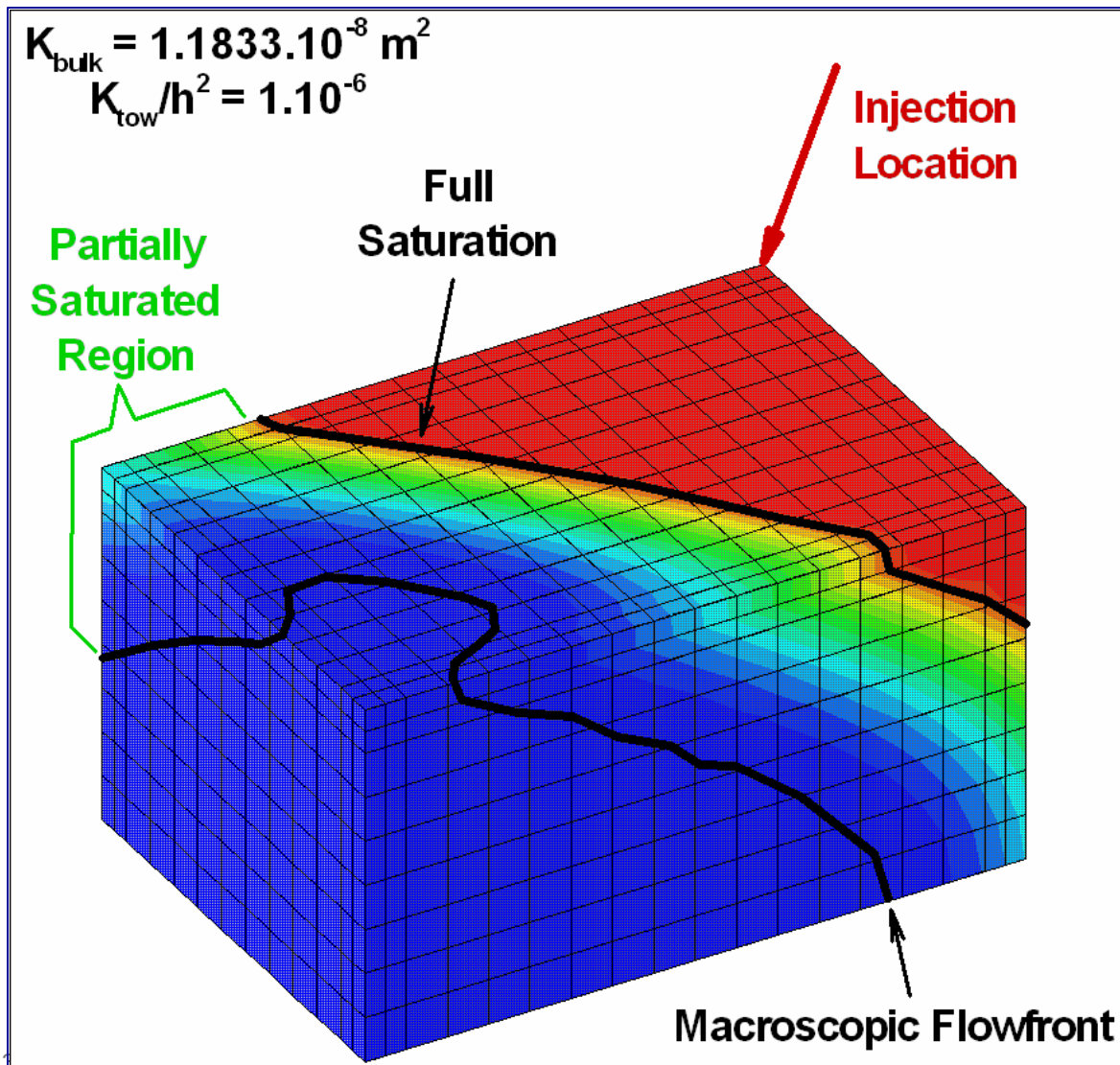

Preform Compaction

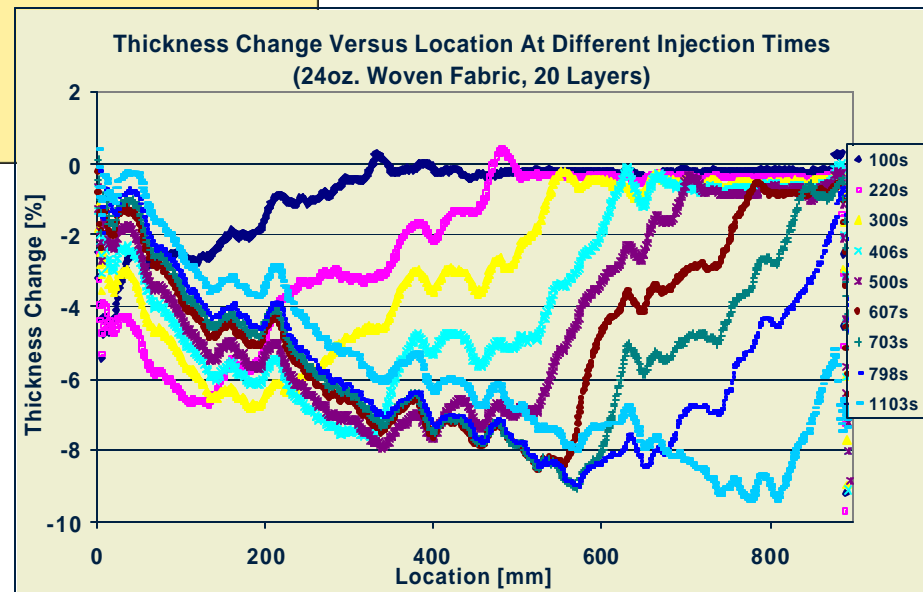
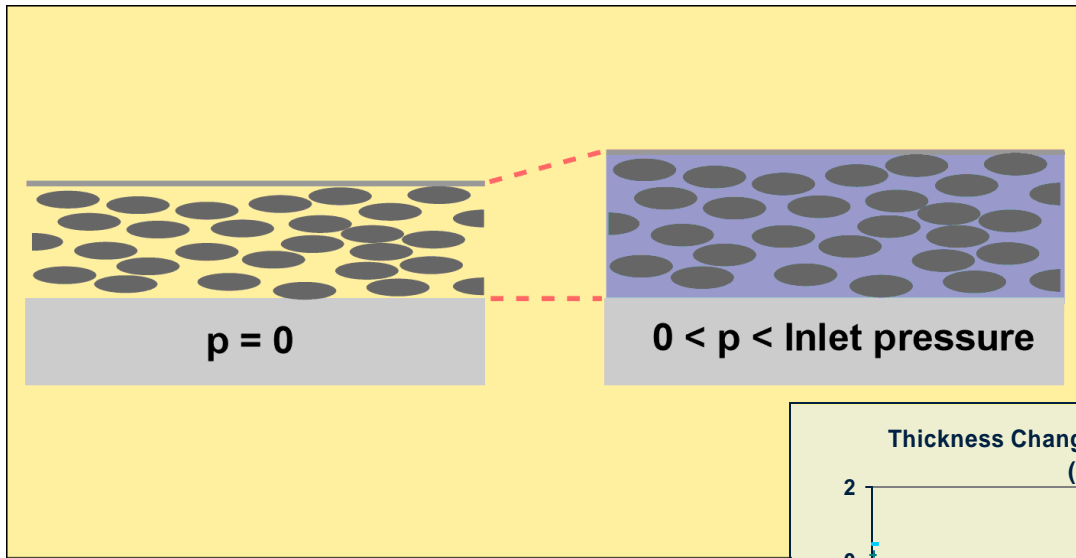

1-D Coupled Flow and Compaction Model

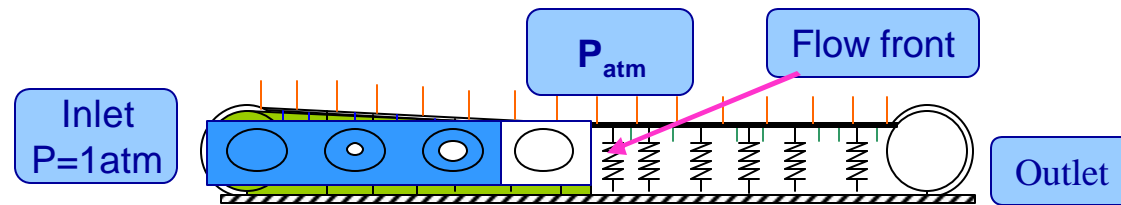

$$\frac{\partial}{\partial x} \left(K_{xx} \frac{v_i}{v_f} \frac{\partial P}{\partial x} \right) = m \frac{\partial}{\partial t} \left(\frac{v_i}{v_f} \right) + \frac{2K_{TOW} P}{R^2} \frac{v_f}{v_{fTOW}} \frac{\sqrt{1-S}}{1-\sqrt{1-S}}$$

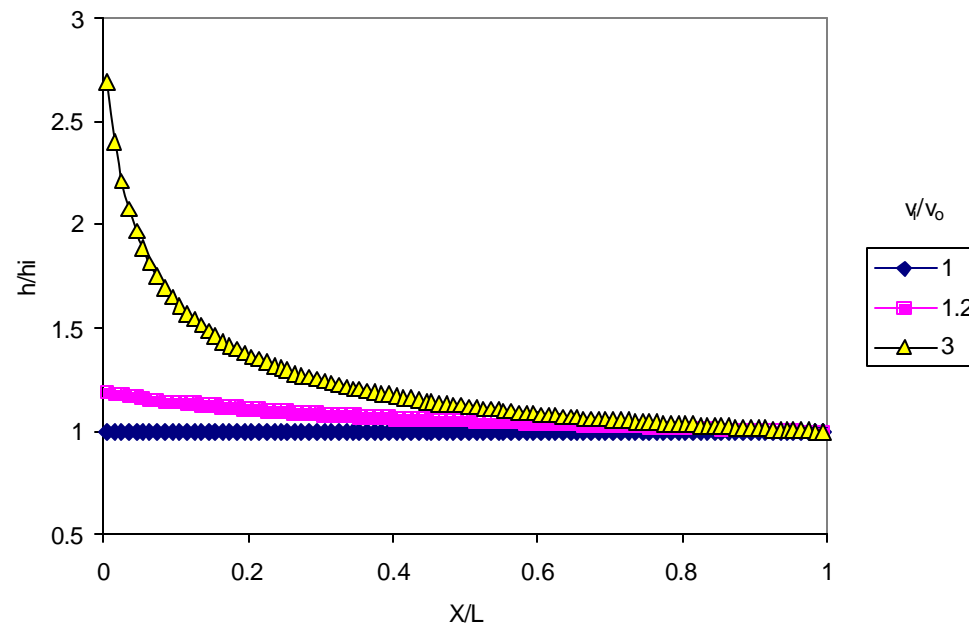

Distribution Media Modeling

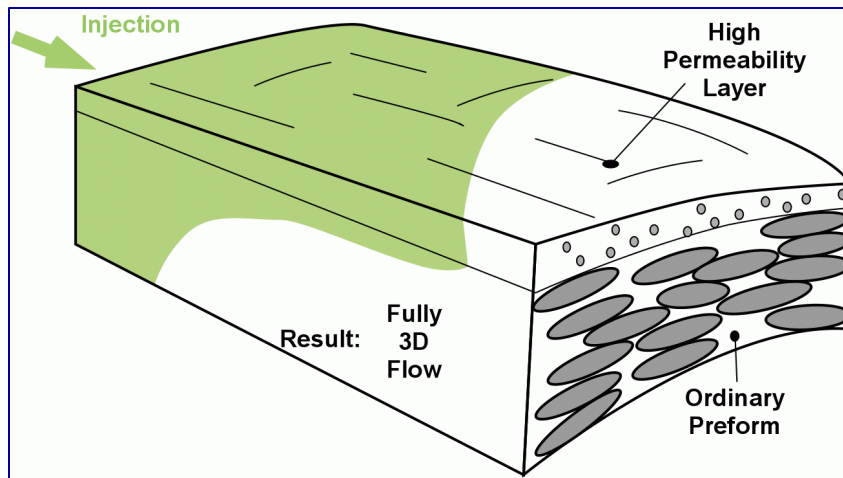

- 3-D flow effects
- Distribution media layer is thin
- Numerical difficulties in 3-D modeling
 - ◆ Element aspect ratio is high

How To Model Distribution Media?



- **How to Defeat Numerical Problems with High Aspect Ratio Elements?**

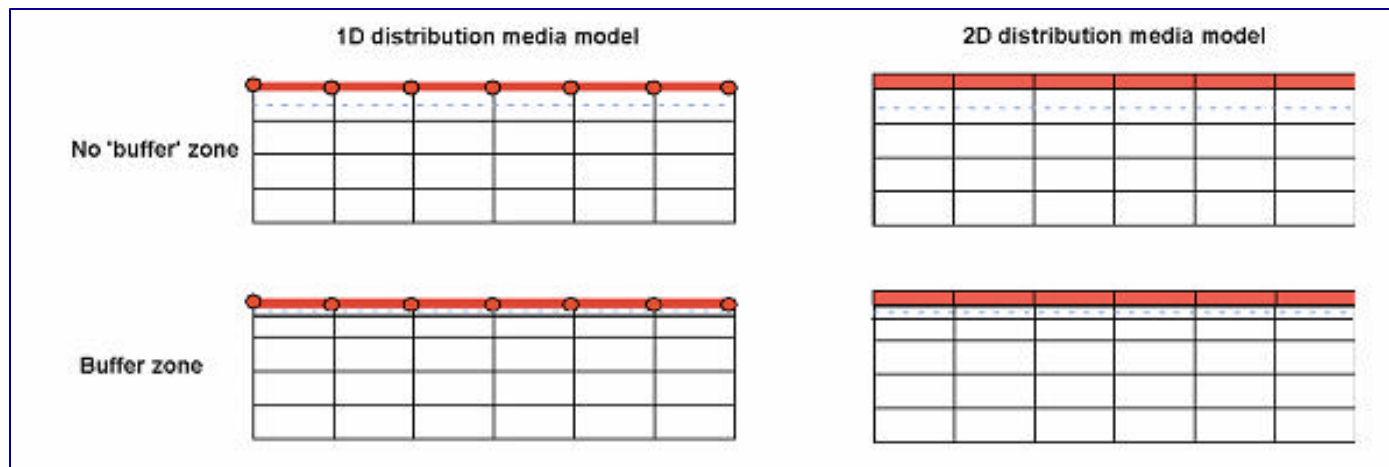

- **How Coarse Can the Mesh Be?**
- **How to Address the Unknown DM Transverse Permeability?**

Problem- Resin Wastage

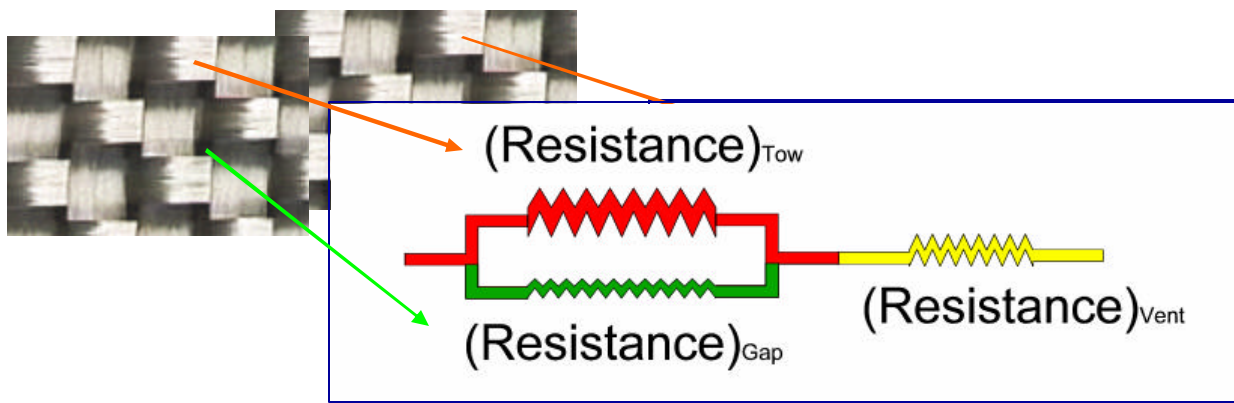
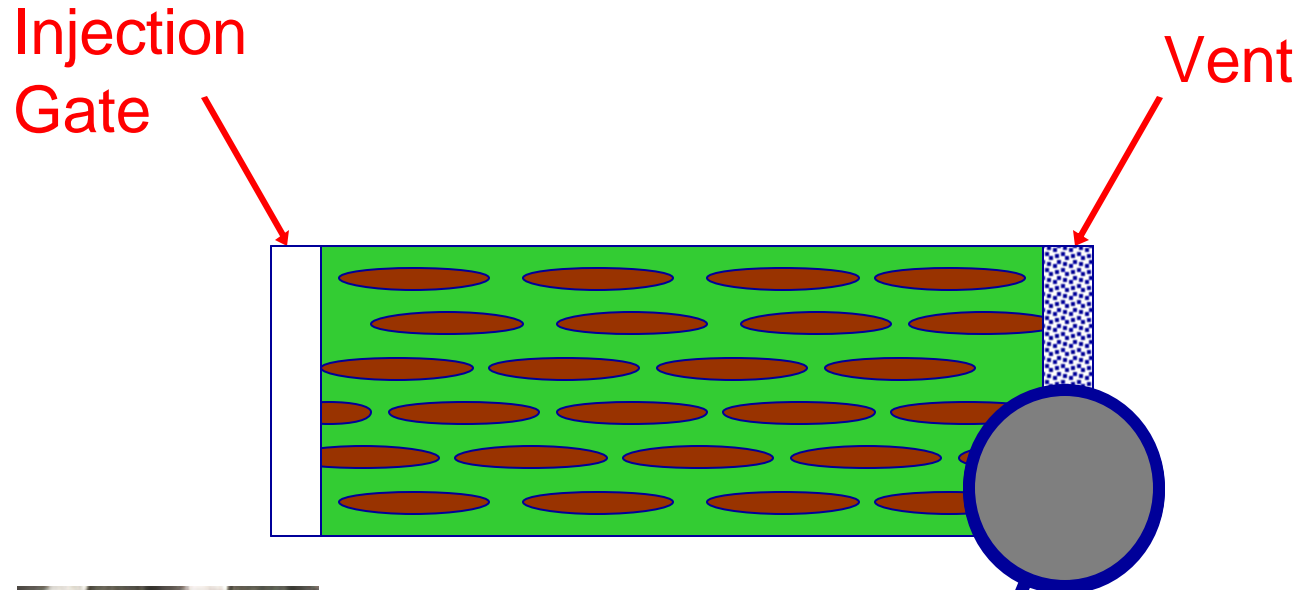

Influence of Vent Resistance

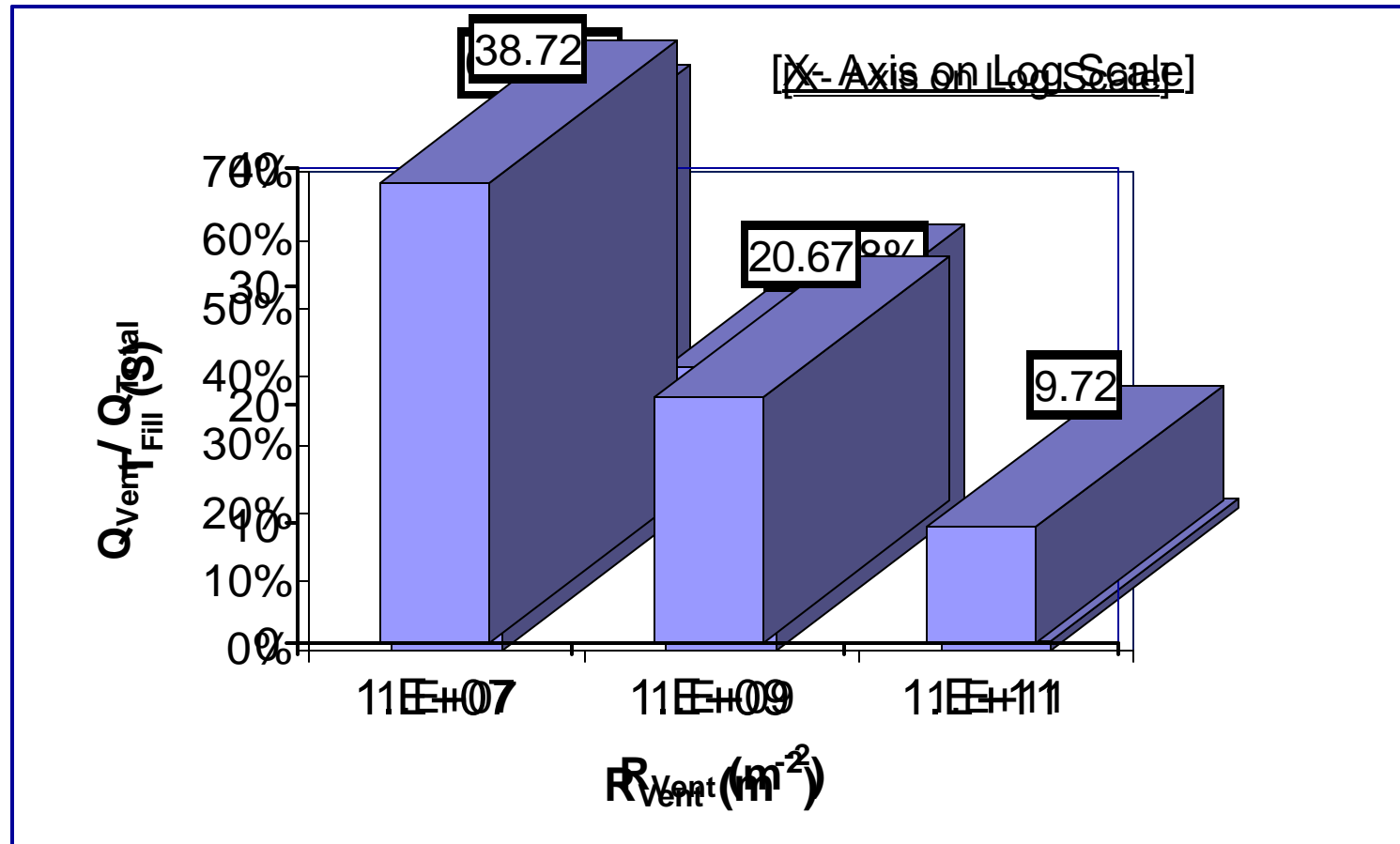

Design and Optimization

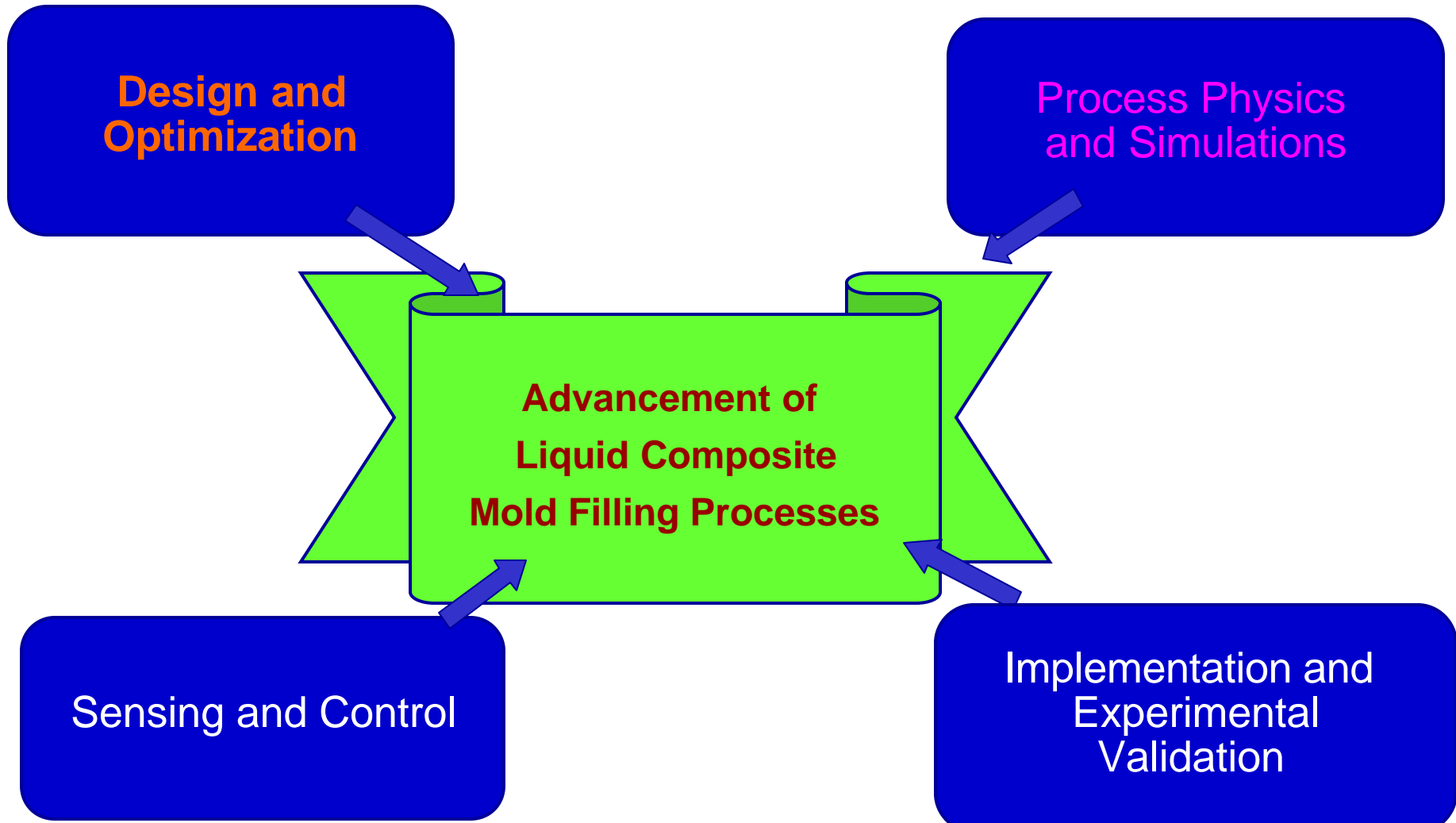

Design for Best Gate Location



Criteria:

- **Minimum no of Gates**
- **Minimum Fill Time**
- **No Voids**
- **Low Pressures**

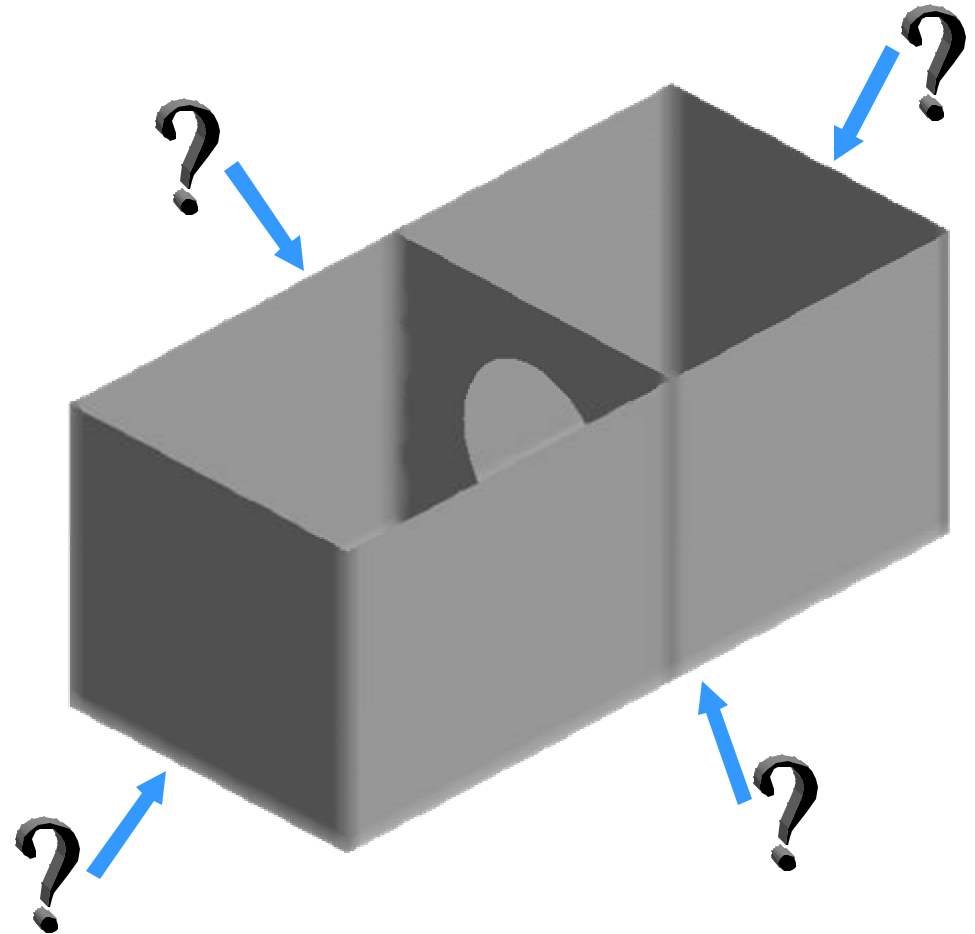

Approach to Use of Simulations for Design, Optimization and Control

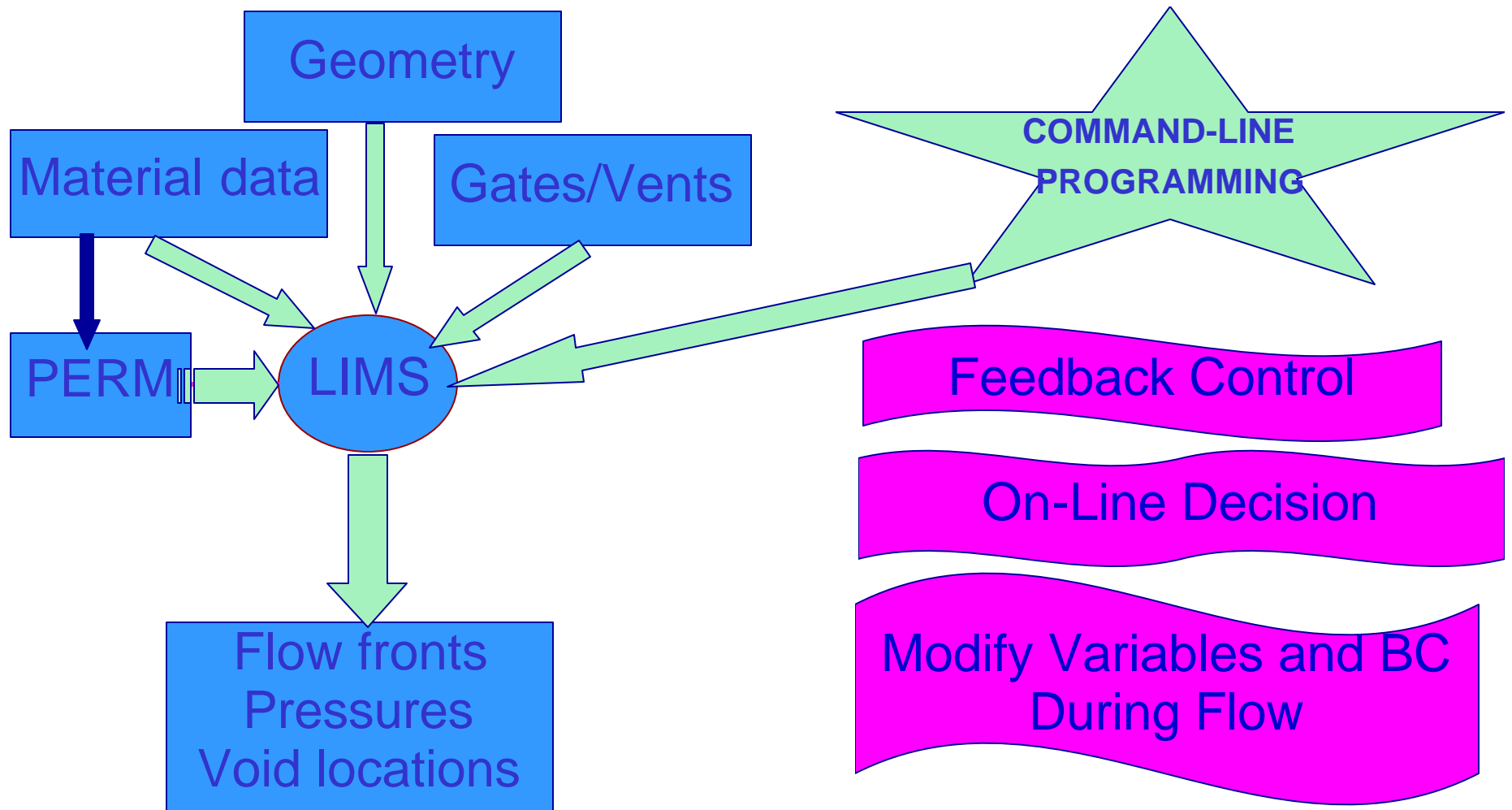

Command Line Control



Script file:

```

proc series

settime 0.0
read "ellshape.in"
setgate 51,1,500000
auto
setouttype "tplt"
write "ell_1"

settime 0.0
read "ellshape.in"
setgate 51,0,0
setgate 1301,1,500000
auto
setouttype "tplt"
write "ell_2"

settime 0.0
read "ellshape.in"
setgate 51,0,0
setgate 1963,1,500000
auto
setouttype "tplt"
write "ell_3"

endproc series
    
```

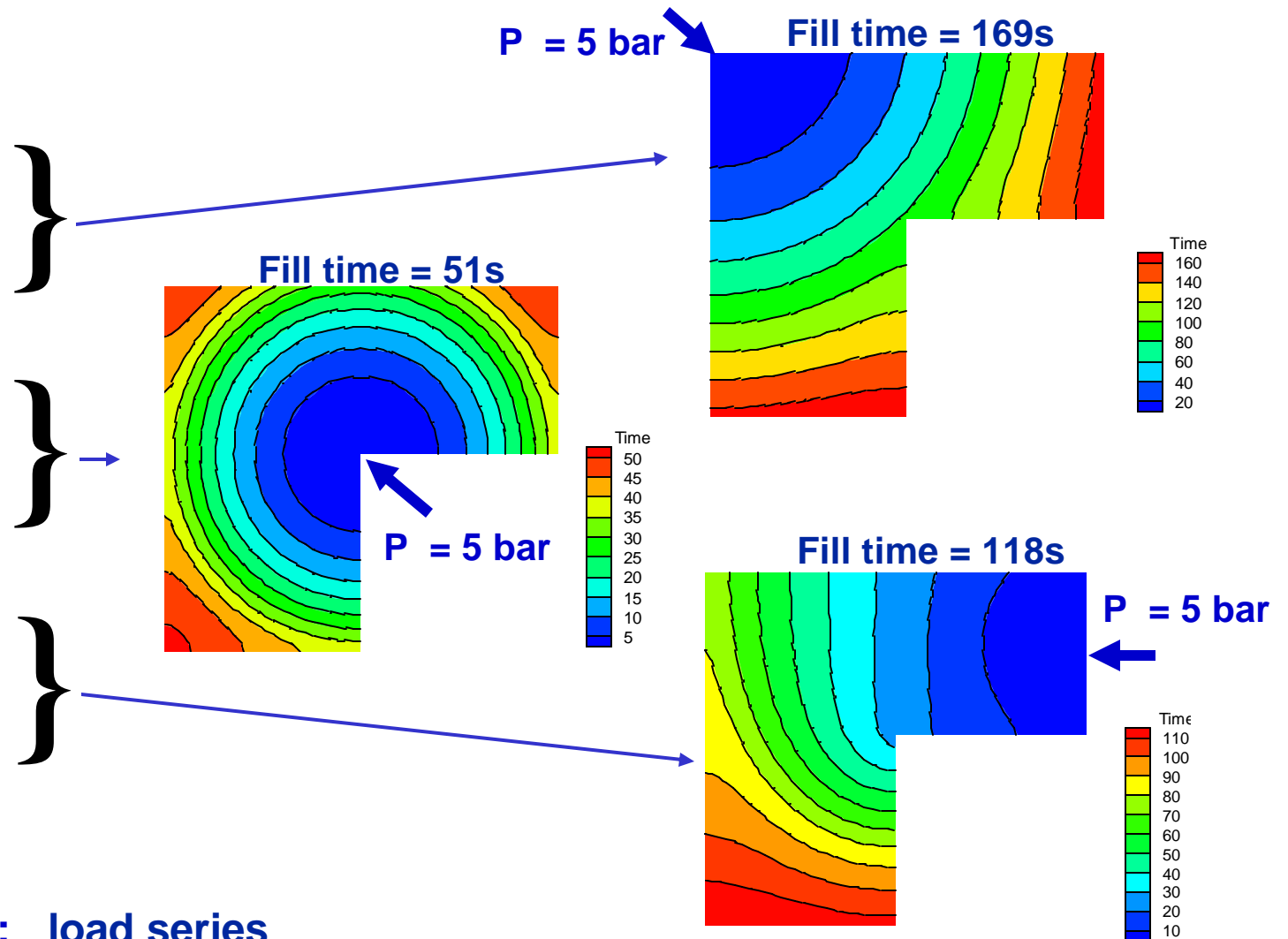

On command-line: load series

Model-Based Optimization

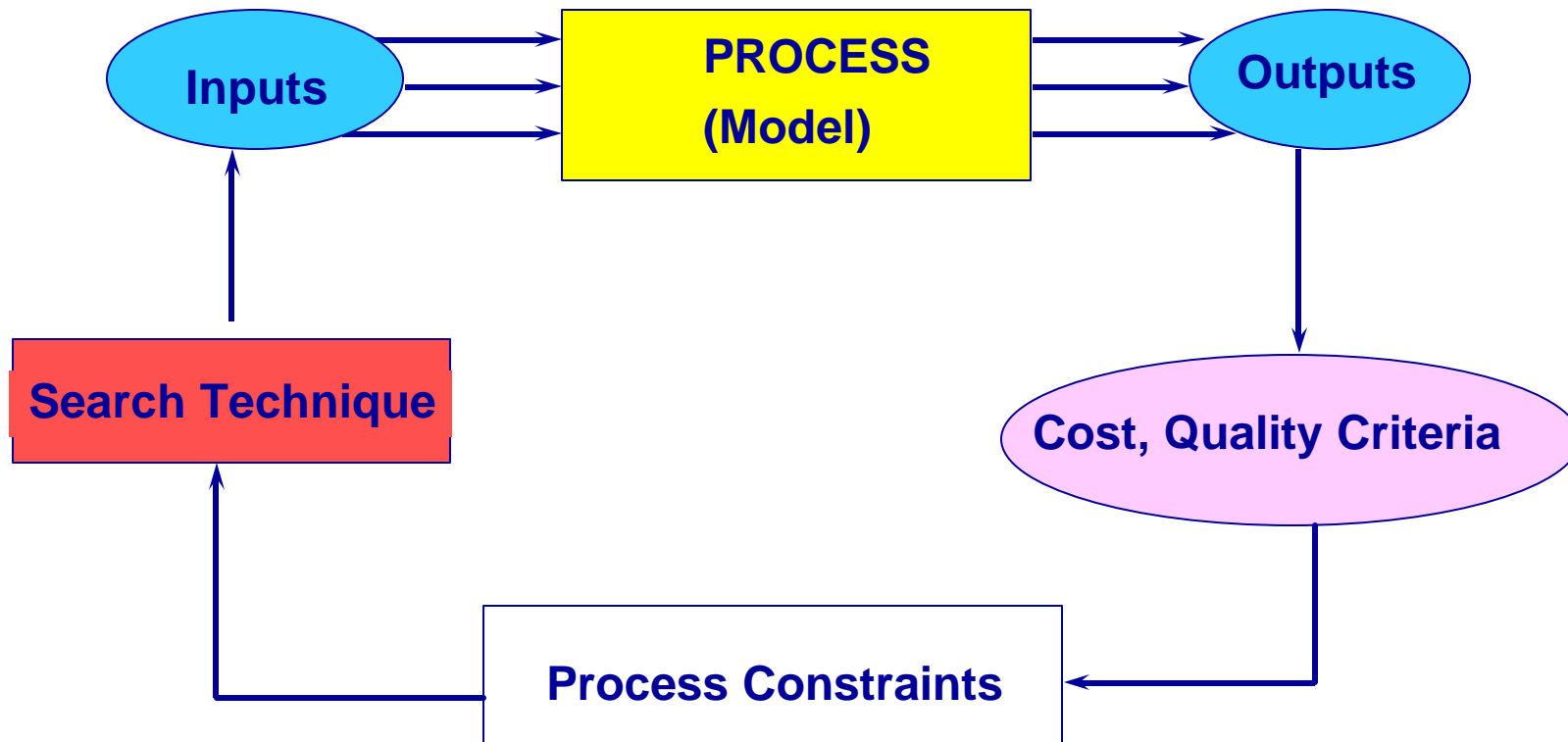

Search Techniques :

- **Heuristic (Experimental / Experience based)**
- **Analytical (Gradient Based)**
- **Probablistic (genetic algorithms)**

Branch and Bound Search (BBS)

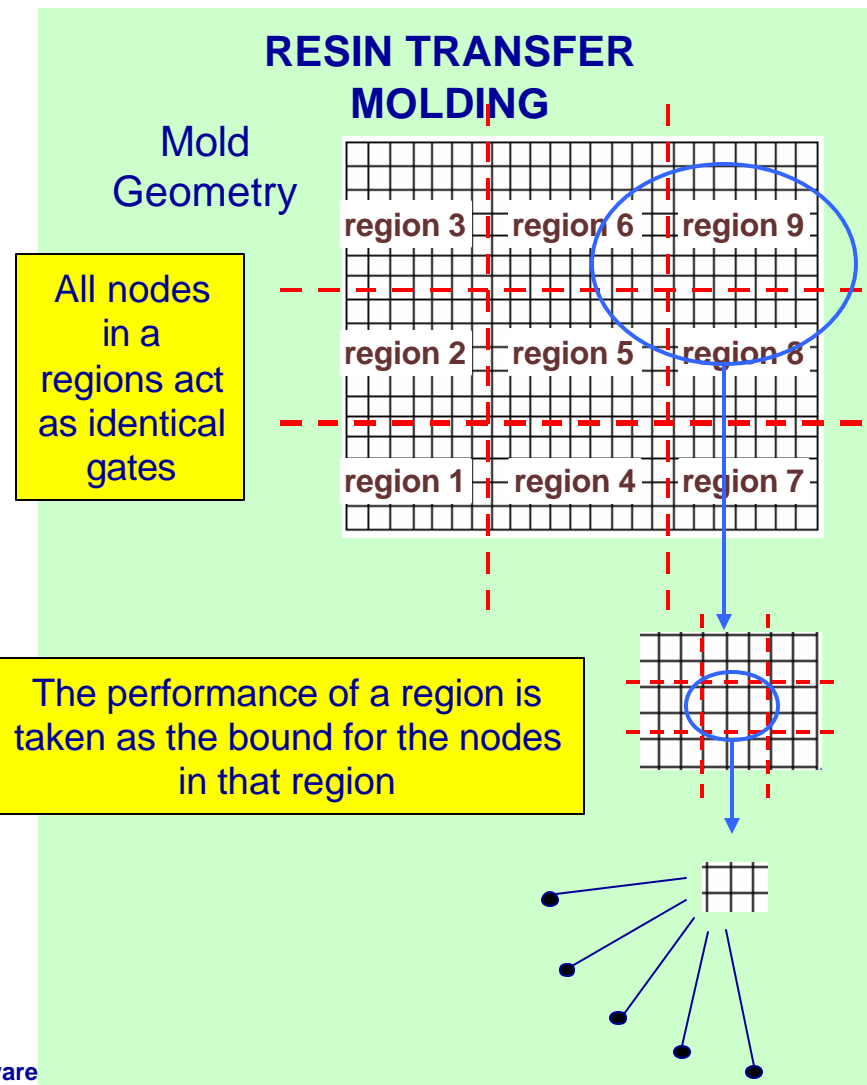
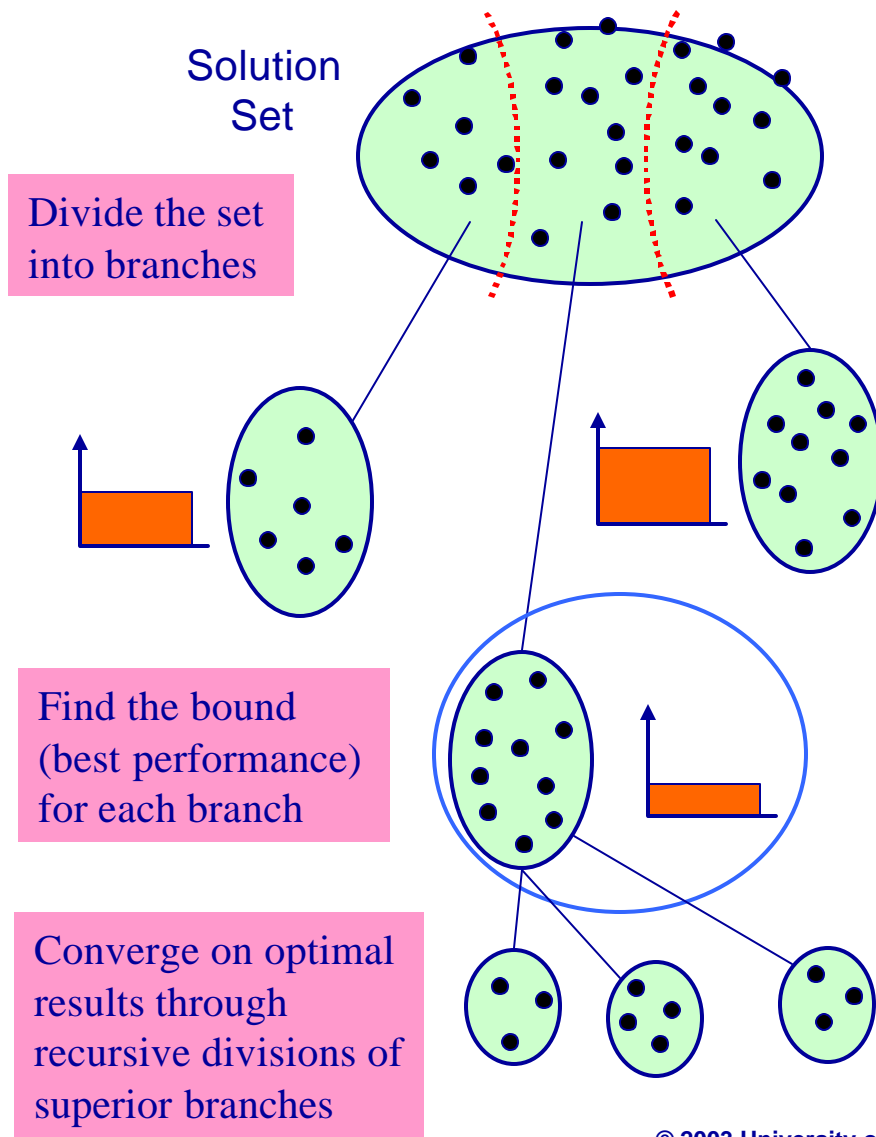

Results & Comparison - Box Mold

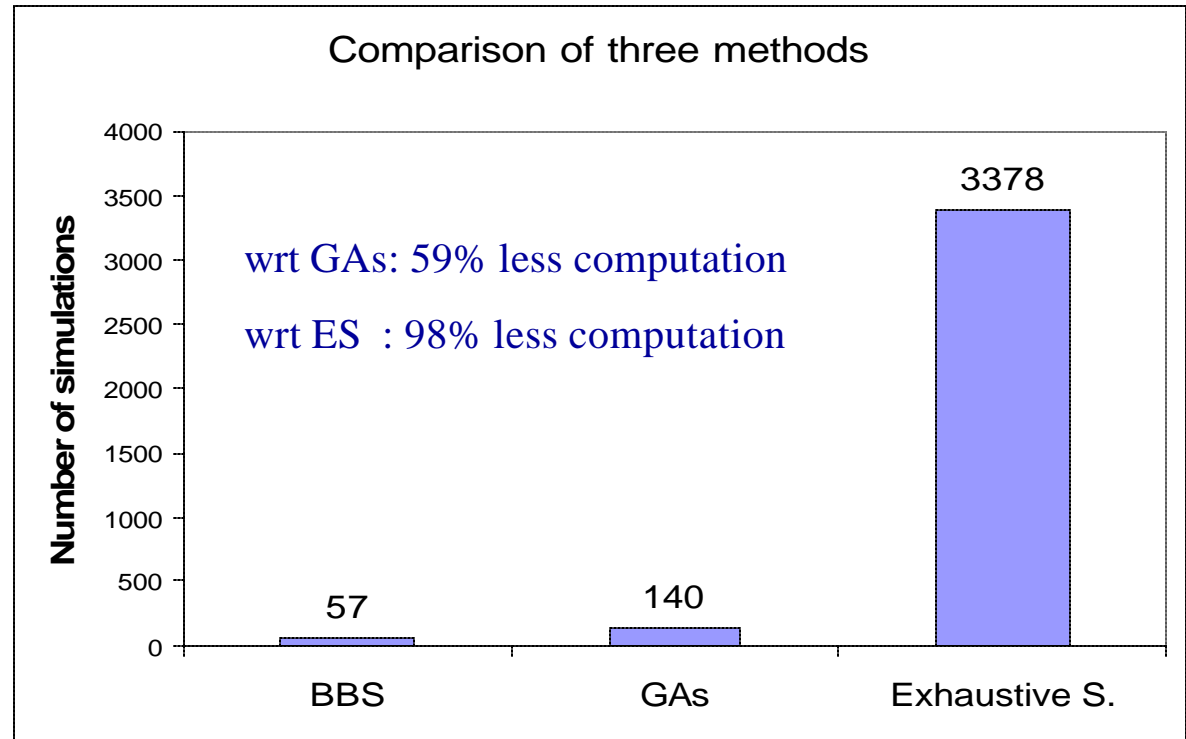
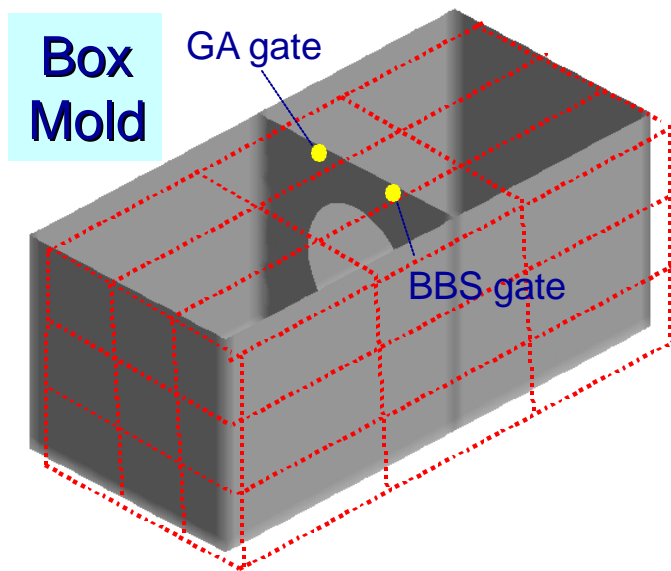

Best Fill Times

BBS: 9995 sec
Genetic Algorithms 10,862 sec
Exhaustive Search 9,995 sec

Use of SLIC to Optimize Distribution Media

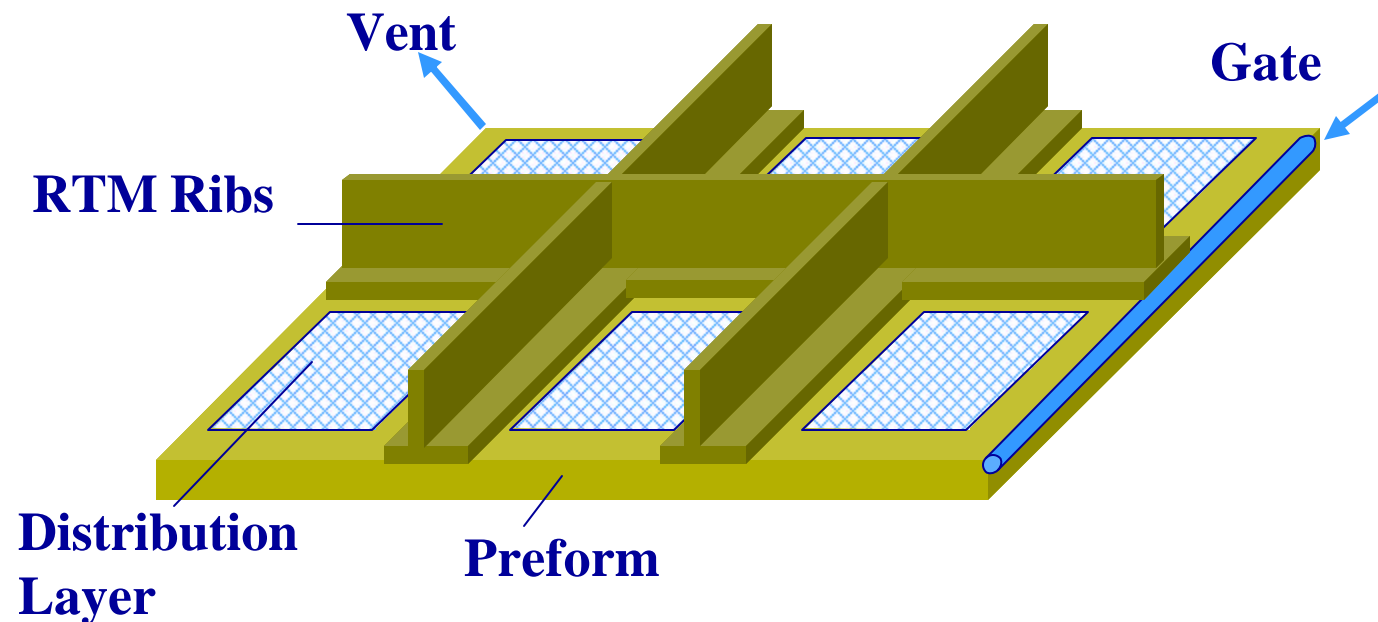

What is the optimized flow distribution network design?

Experimental Set-Up

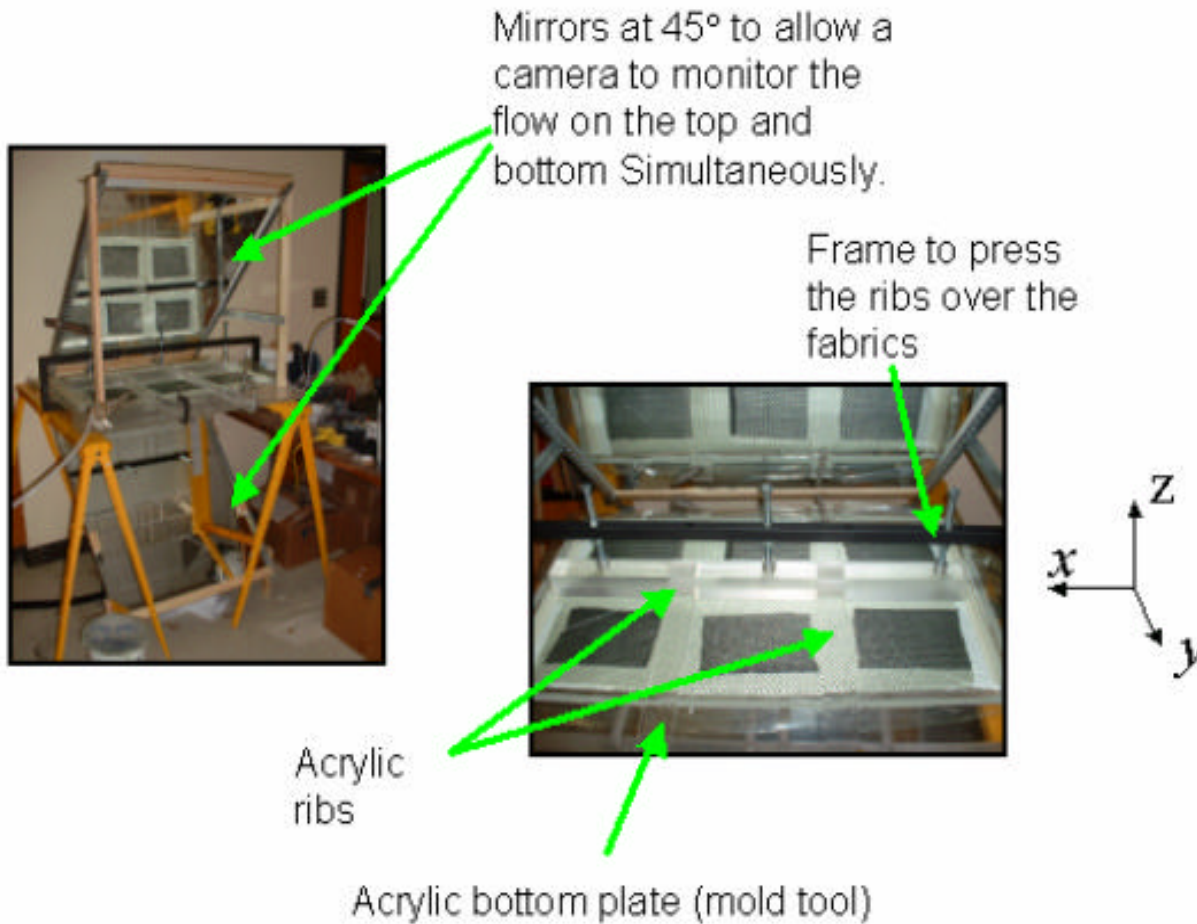

Simulation-Based Approach to Design Distribution Media Lay-Up

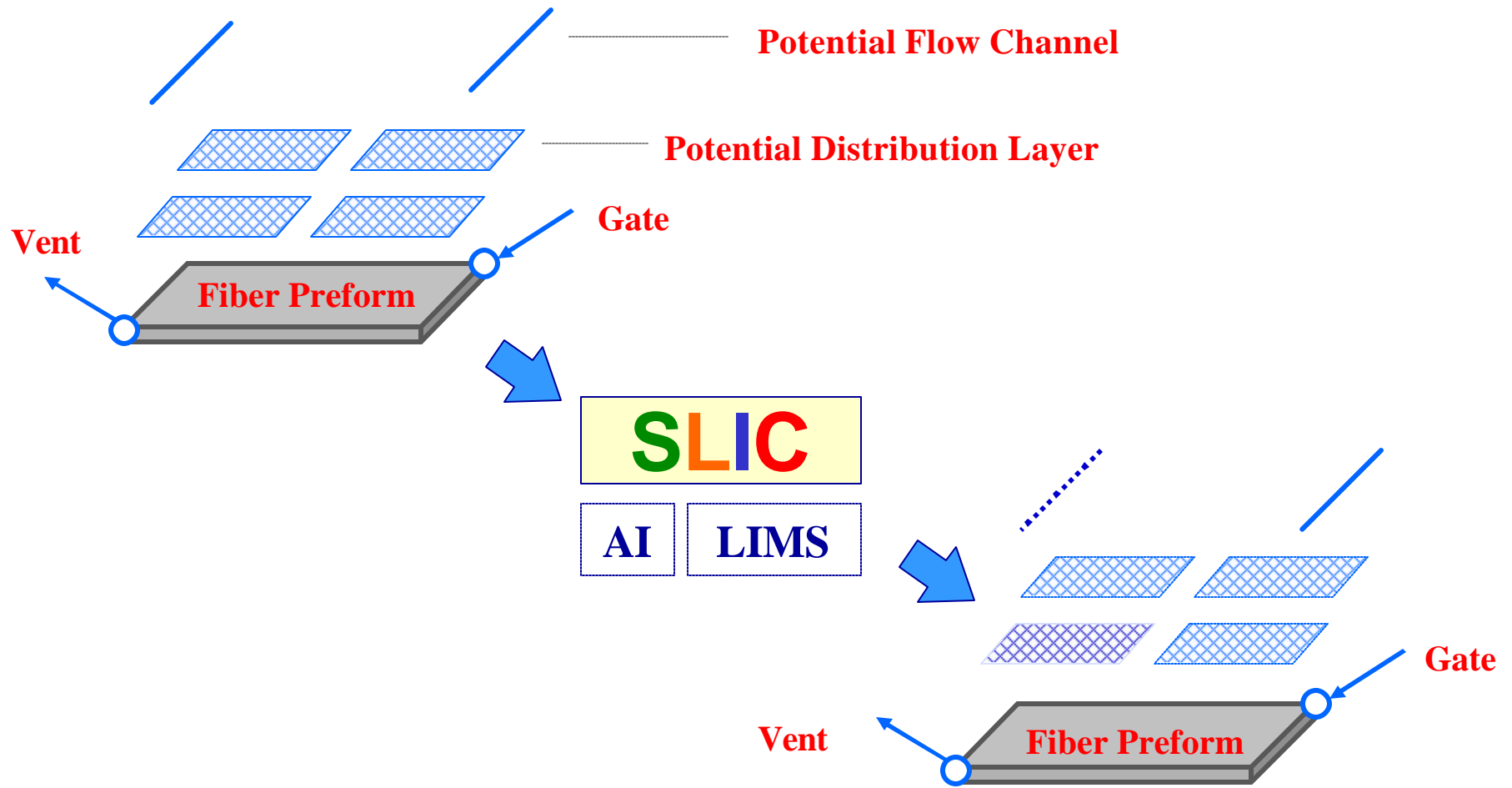

Comparison of Trial and Error Approach with SLIC

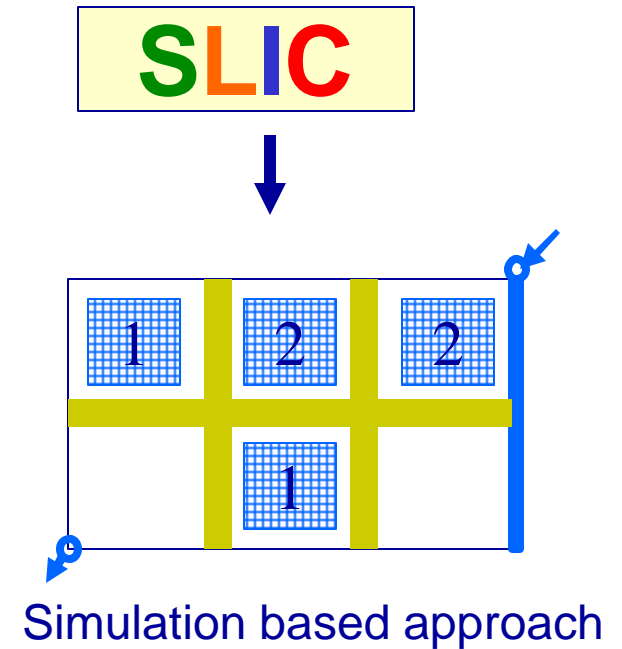
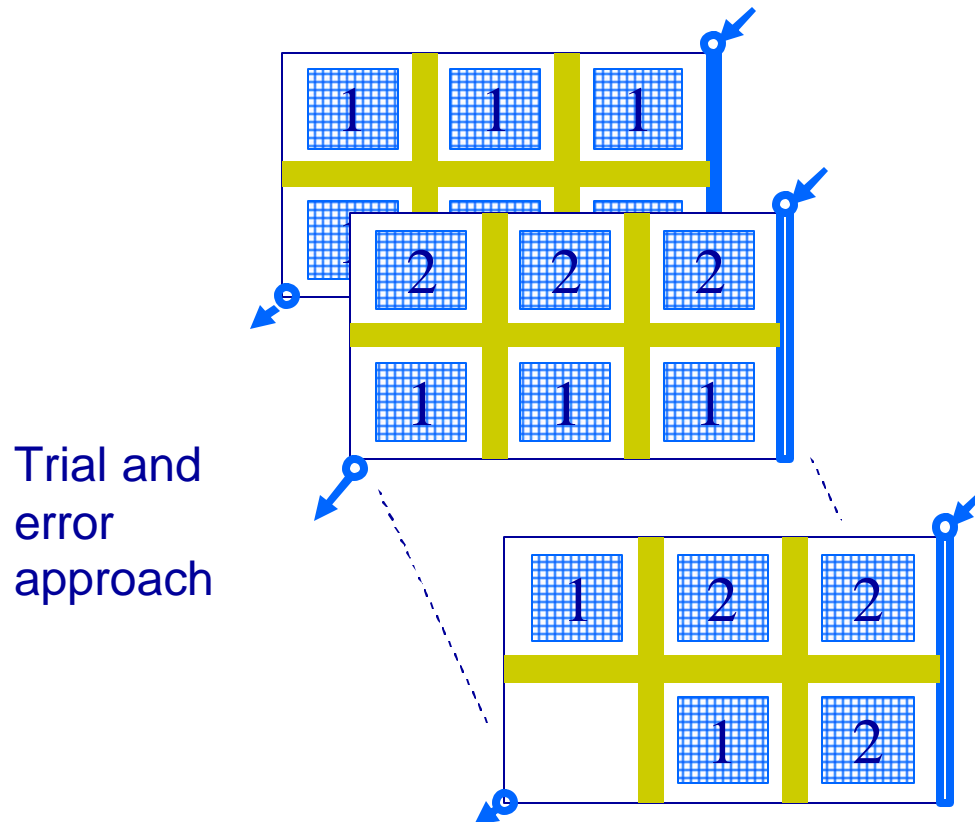

Approach	Trial and Error	SLIC
No of experiment	5	1
Dry spot content	0.86%	0.05%
Filling time	12 min	13 min

Design of Multiple Injection Locations for Large Parts

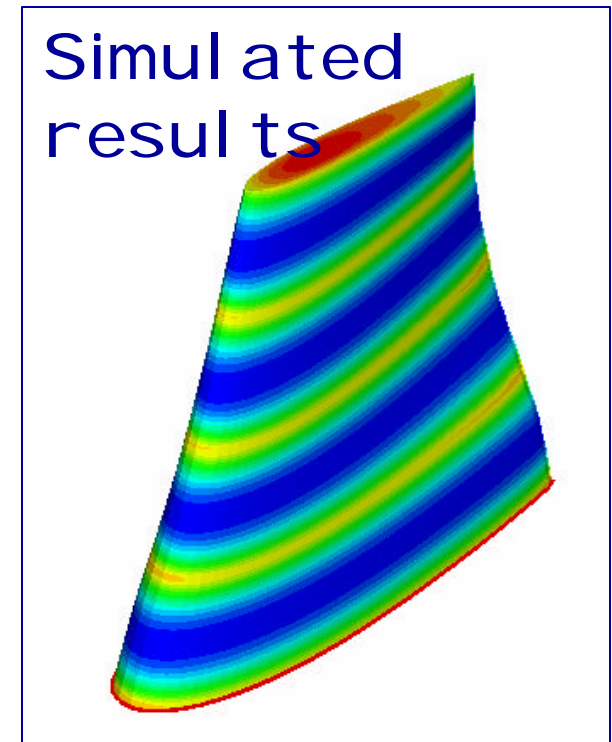
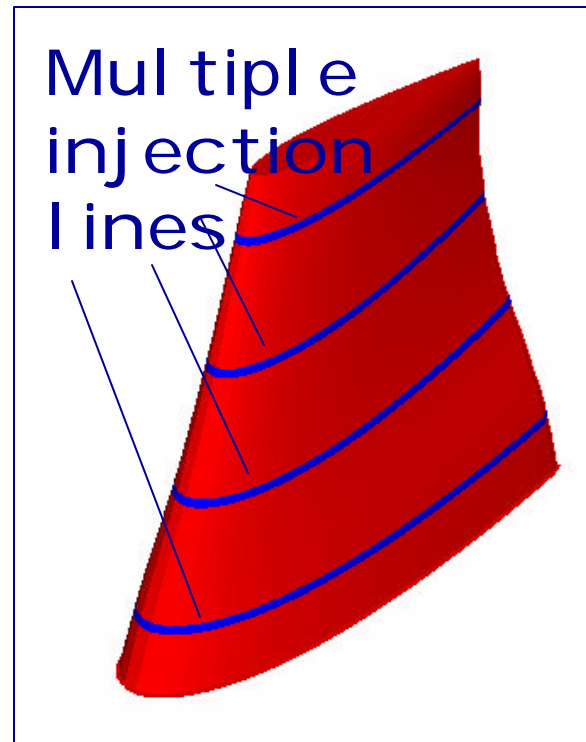

Design of Gates and Vents in the Presence of Flow Disturbances



How to Design Gate
and Vent Locations
In the Presence of
Flow Disturbances?

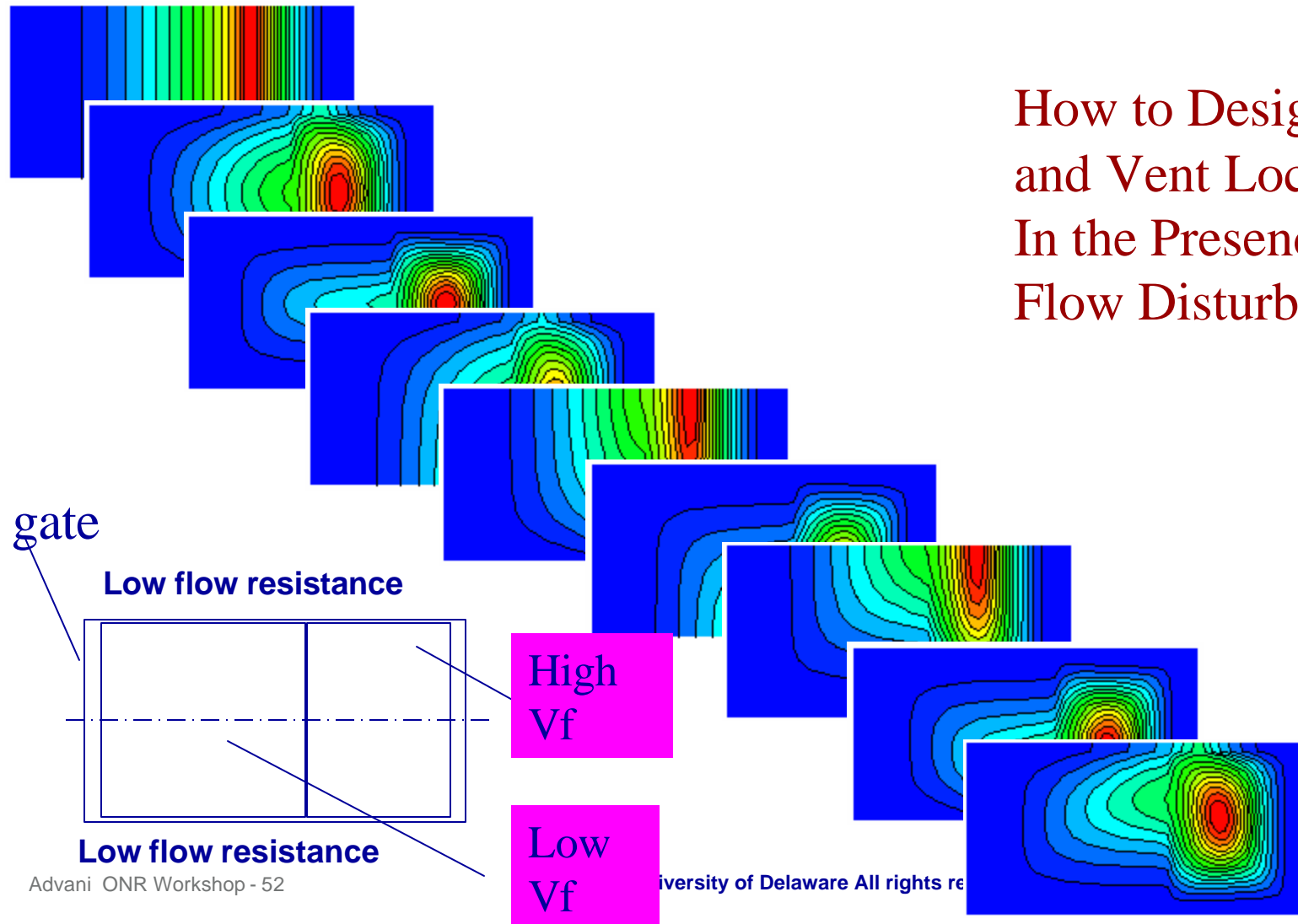

Flow Disturbances



Race-tracking is a dramatic flow disturbance that occurs along paths of relatively low flow resistance and will alter the flow front advancement.

Race-tracking does vary from one experiment to next. This variation mainly results from the uncertainties associated with the cutting and placement of the preform in the mold.

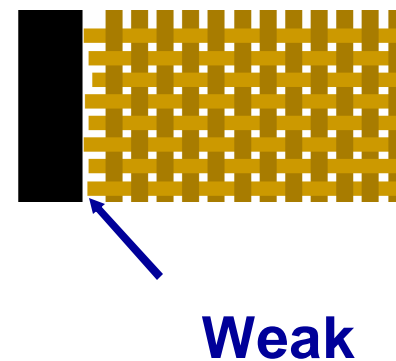
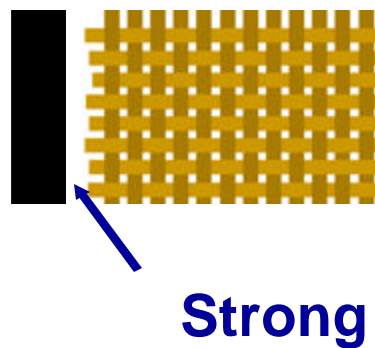

Race-Tracking



Race-tracking is omnipresent :

Transverse
racetracking
in ribs

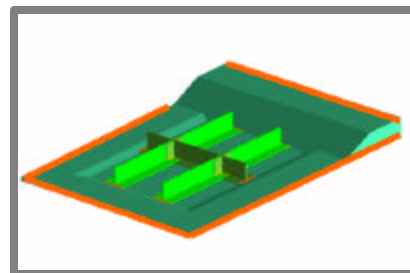
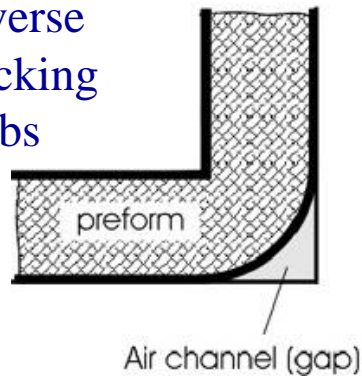

Racetracking along
mold walls

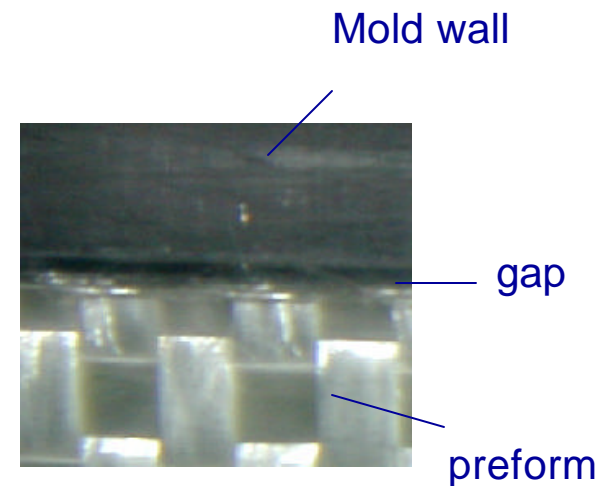

Transverse
racetracking
in tapered regions

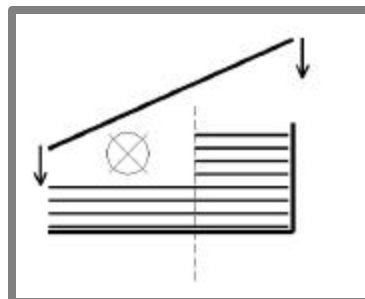

Ribs cut too
short

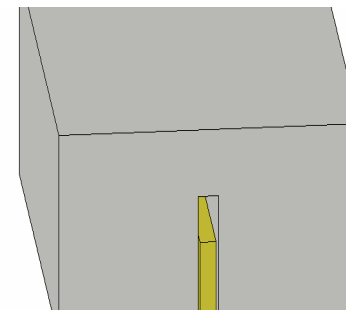

Influence of Race-tracking Strength on Flow Behavior



Different race-tracking strengths will result in different locations for the last region to be filled during each injection

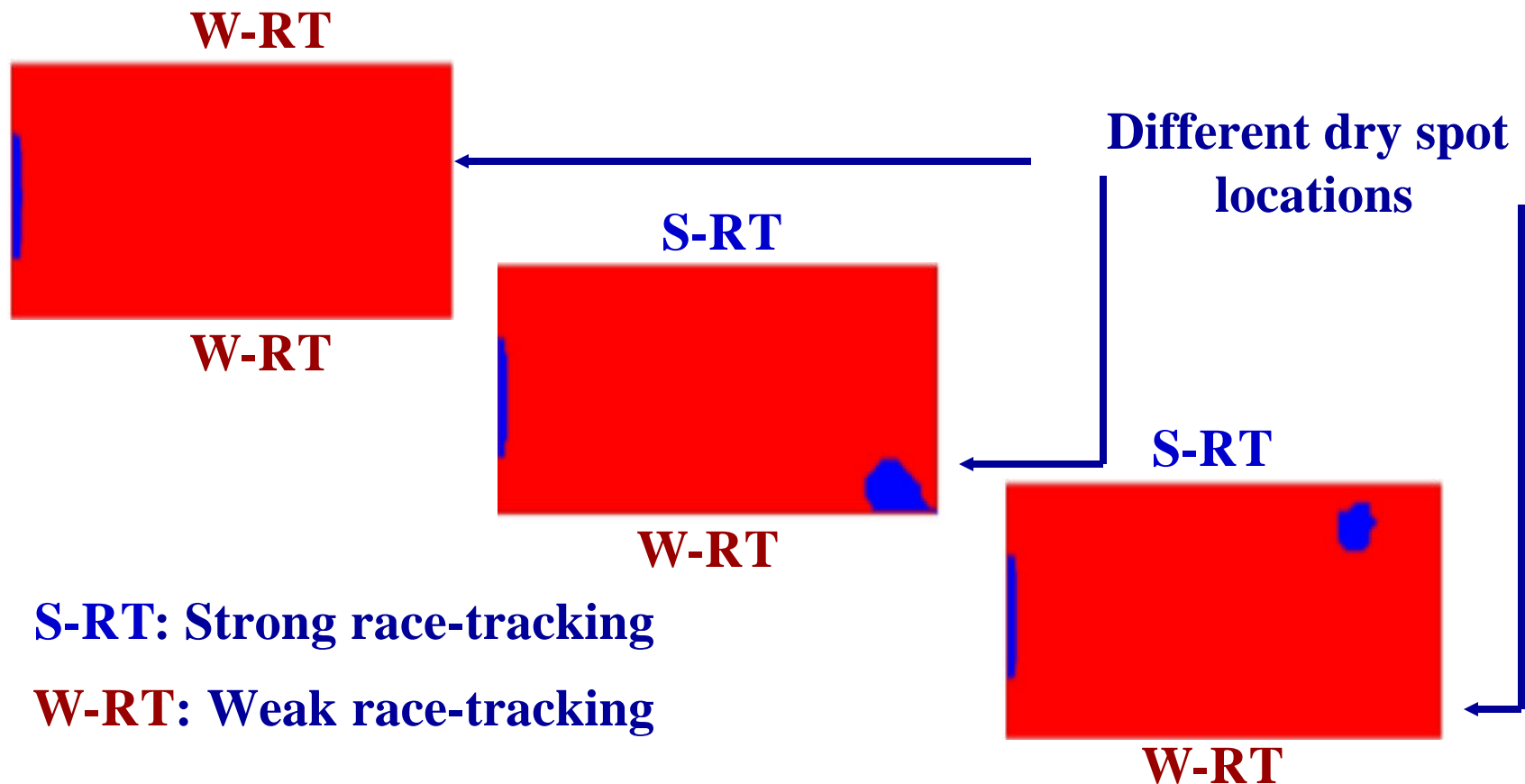

S-RT: Strong race-tracking

W-RT: Weak race-tracking

Race Tracking in 3-D Flow



How the race tracking will influence the flow in 3D is not intuitively obvious

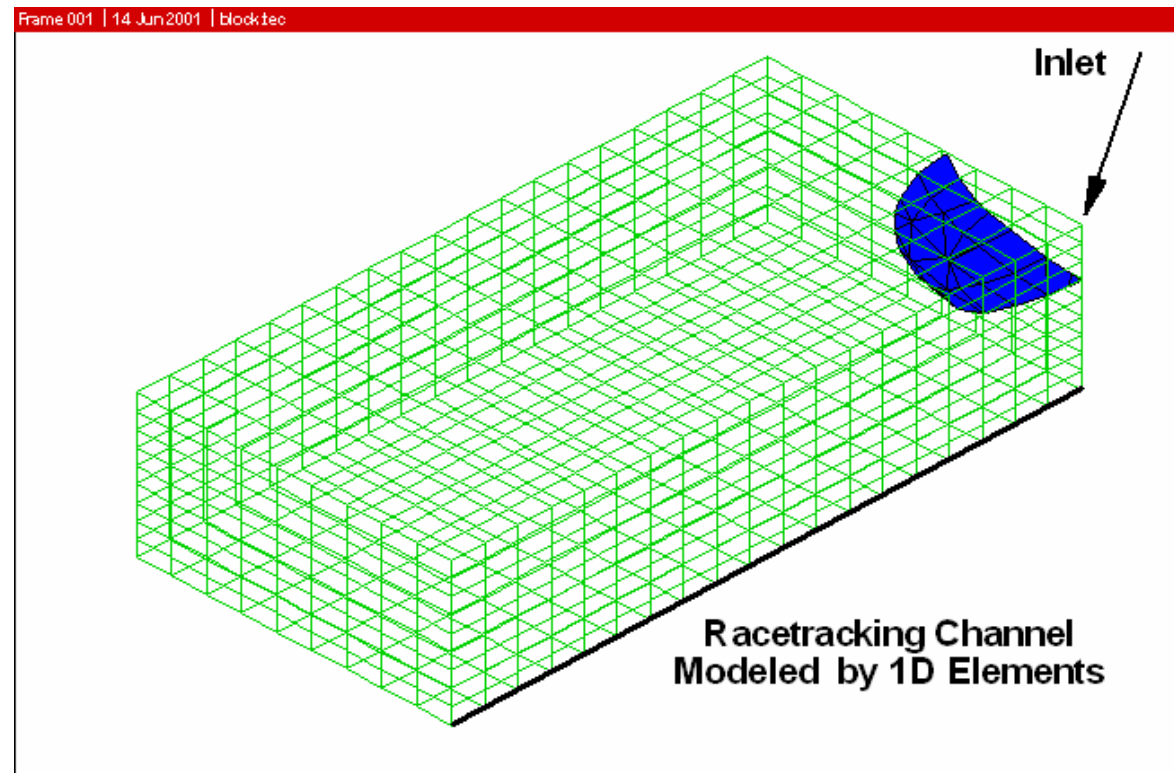

2-D flow front surface shown

Race-Tracking Is Not Repeatable



- More than fifty experiments were repeated to characterize race-tracking to illustrate the variability of the process. (5 different operators conducted 10 experiments each). A, B, C and D cut preforms by hands, E used a laser cutter

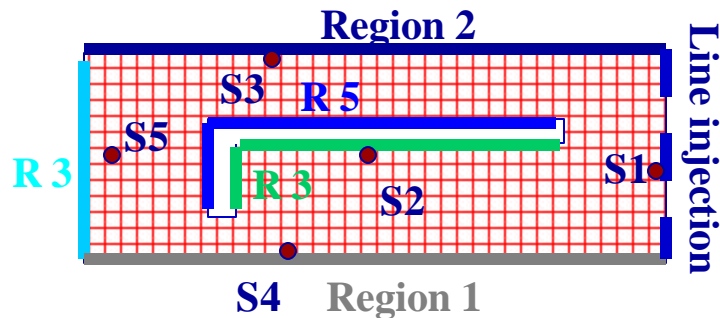

The arrival times of the resin at each sensor are used to characterize the degree of race-tracking along the 5 regions



Mold

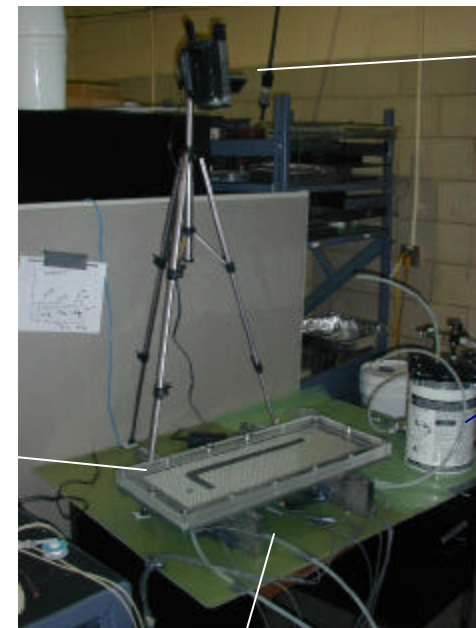

camera

Pressure bucket

Sensor wires

Variation in the Strength of Racetracking



The race-tracking is present and not repeatable on any edge

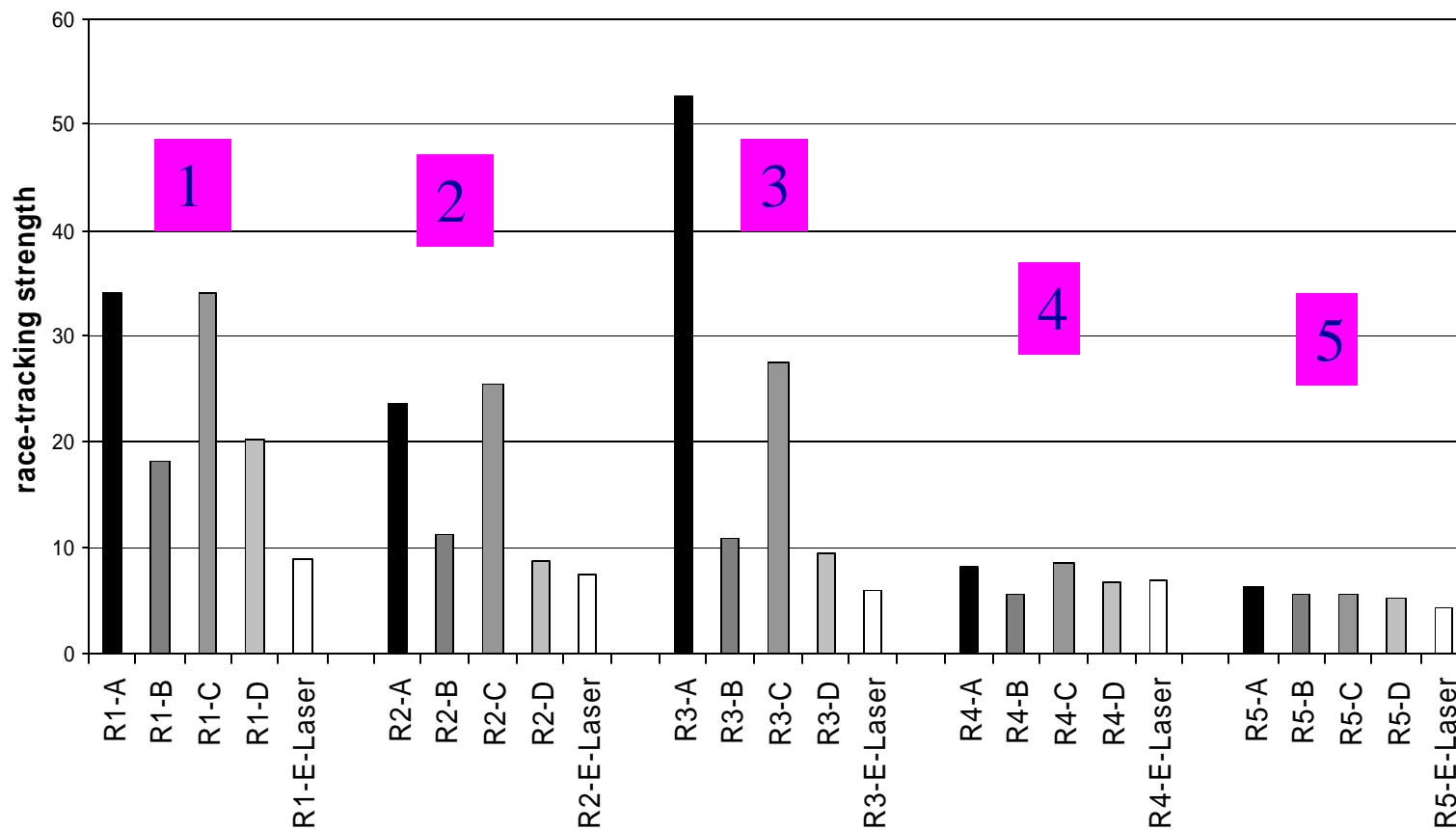

Design Vent Locations with Racetracking Forecast

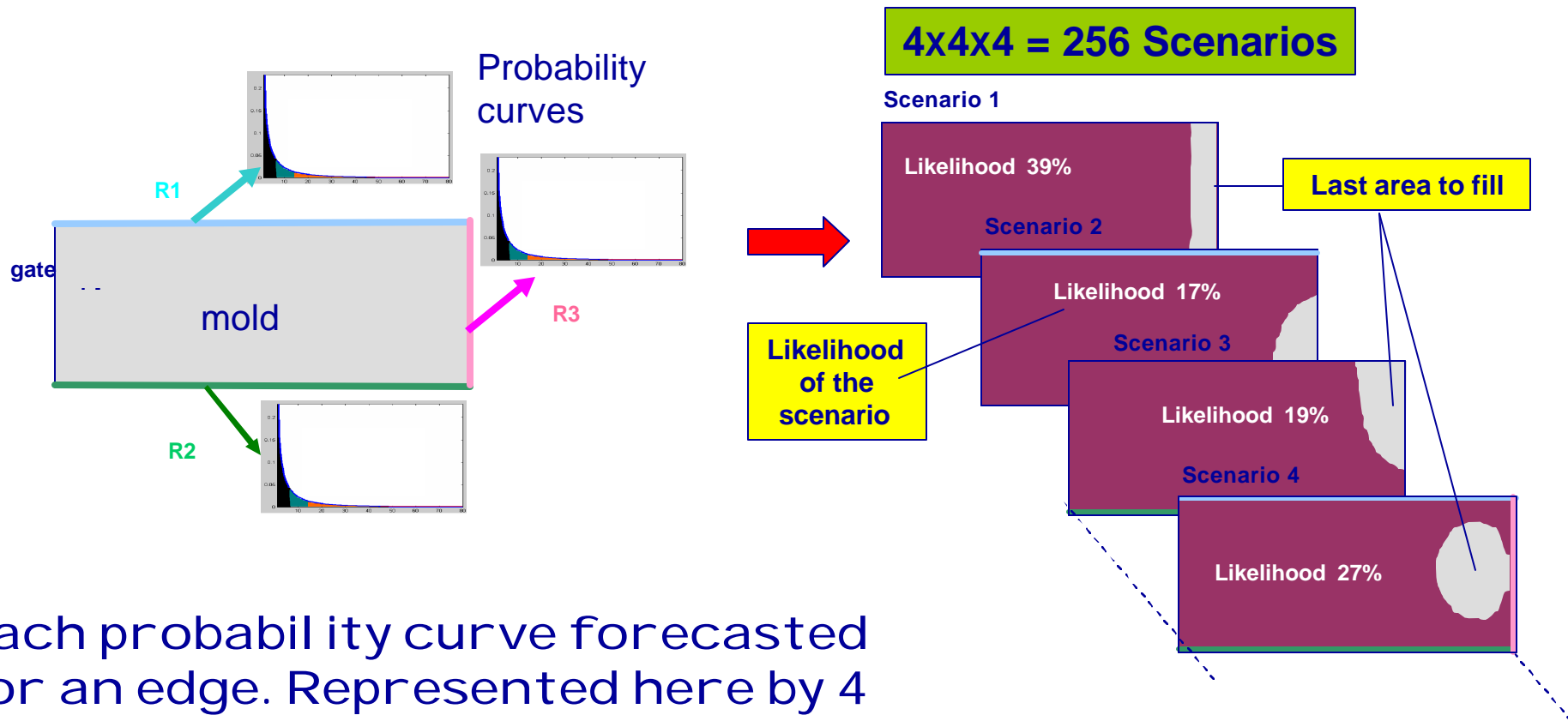

Each probability curve forecasted for an edge. Represented here by 4 discrete values. Hence the scenarios possible will be $4 \times 4 \times 4 = 4^3$.

Vent Optimization



1. Superimpose all scenarios

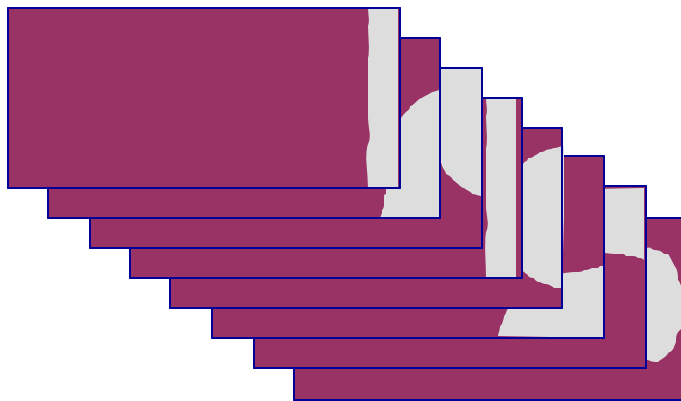

A COMBINATORIAL SEARCH algorithm is developed to find optimal vent locations

Areas with higher % values are more likely to be filled last, hence they are better locations for vents.

2. Intersect last filled areas

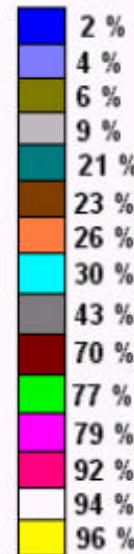
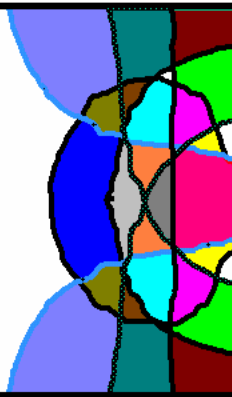

The legend shows the likelihood of different colored mold regions becoming a last filled area.

3. Add the probabilities of scenarios that cover the same region

Experience vs. Combinatorial Vent Design



5 racetracking channels are identified

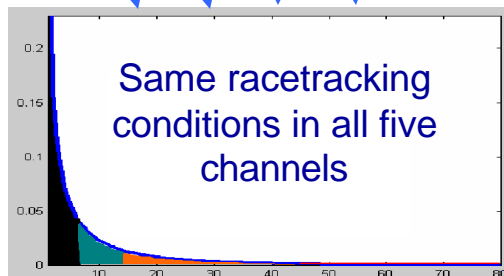
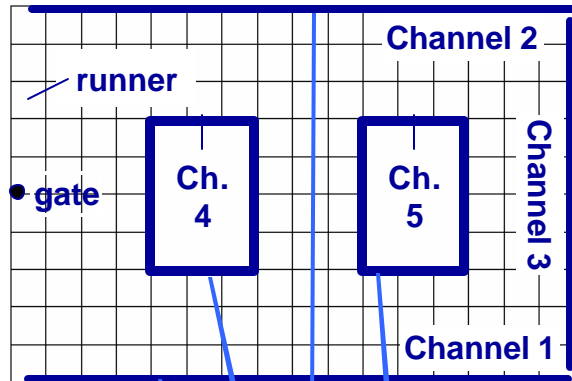

- Racetracking forecast is continuous
- Discretized into four values for each channel
- Hence $4^5 = 1024$ scenarios

Intuition based design

Success Rate: 28%

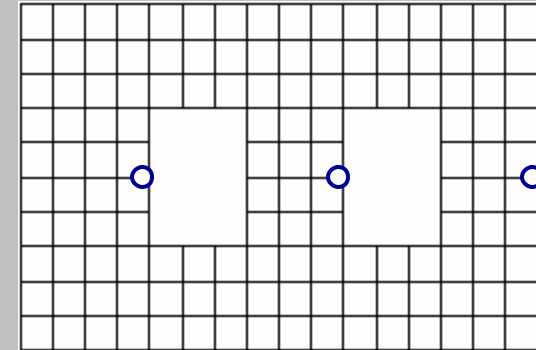

- Last filled region distribution is found
- Combinatorial Search is conducted to find optimal 3 vent locations

Combinatorial Search

Success Rate: 69%

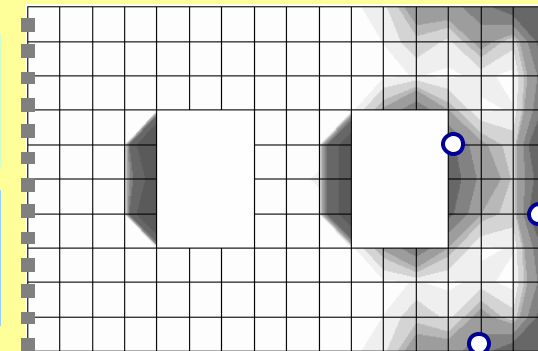

Sensing and Control

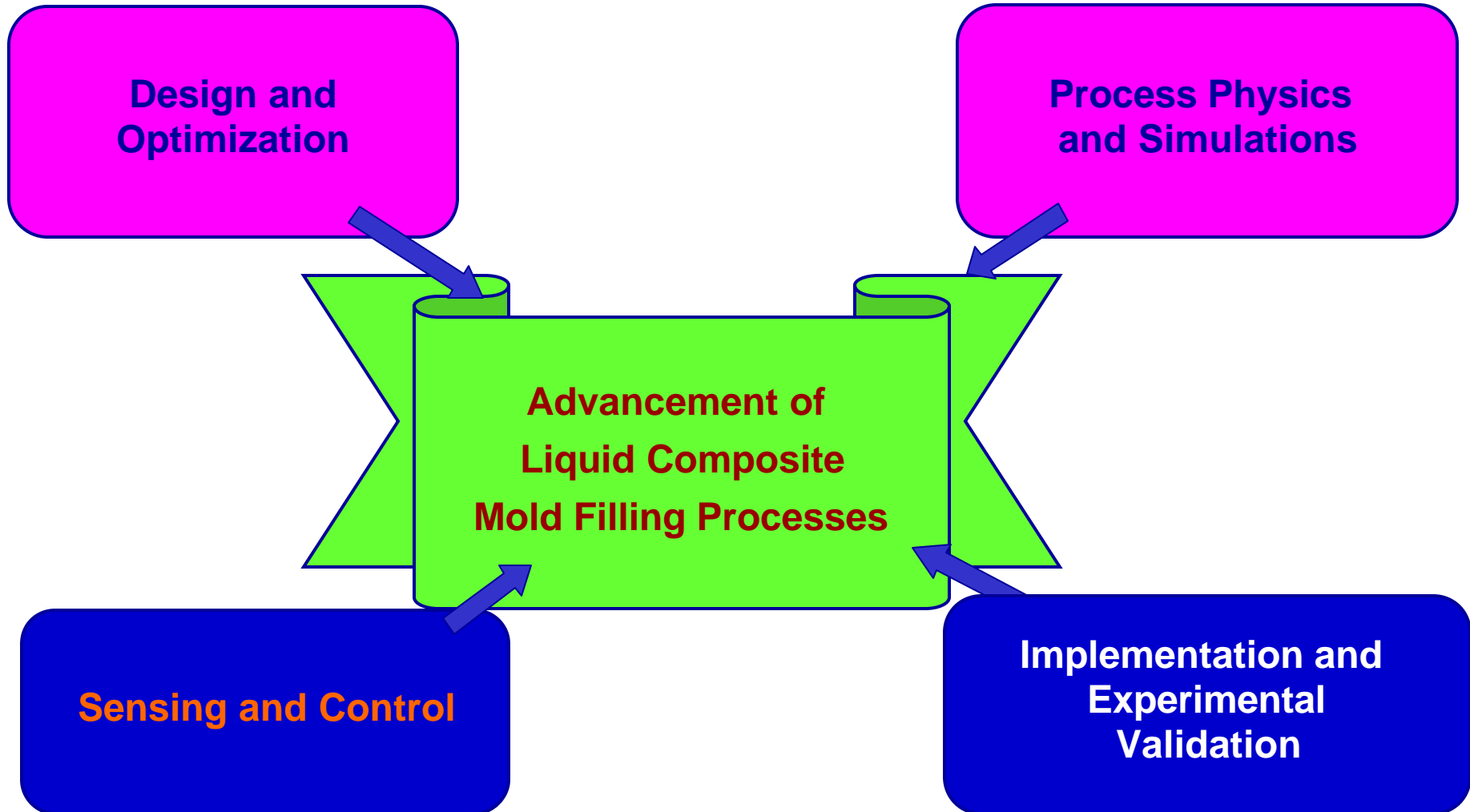

Simulation of Intelligent Injection with Virtual Sensors



T1	ON	OFF	OFF	OFF
T2	OFF	ON	OFF	OFF
T3	OFF	OFF	ON	OFF
T4	OFF	OFF	OFF	ON

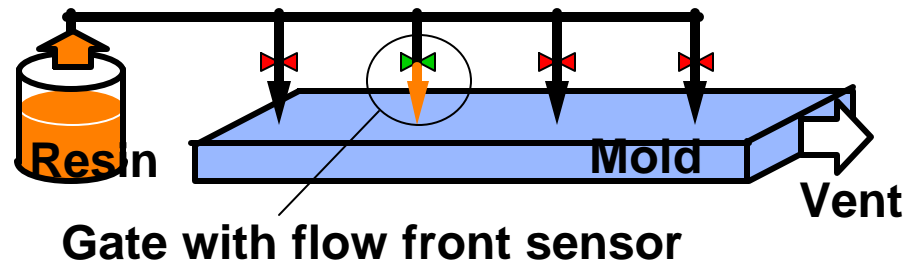

Single Gate Injection



Multiple Gates Injection

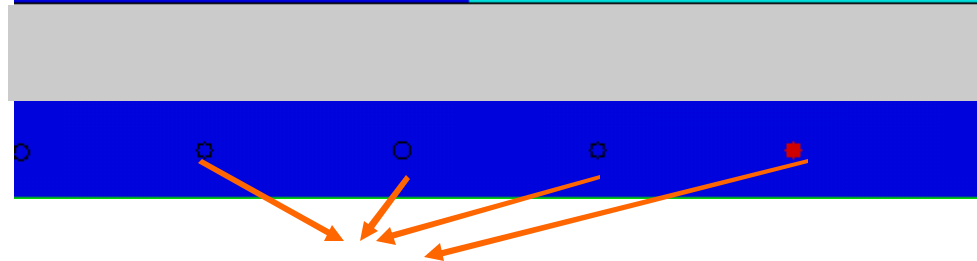

Control Design Approach

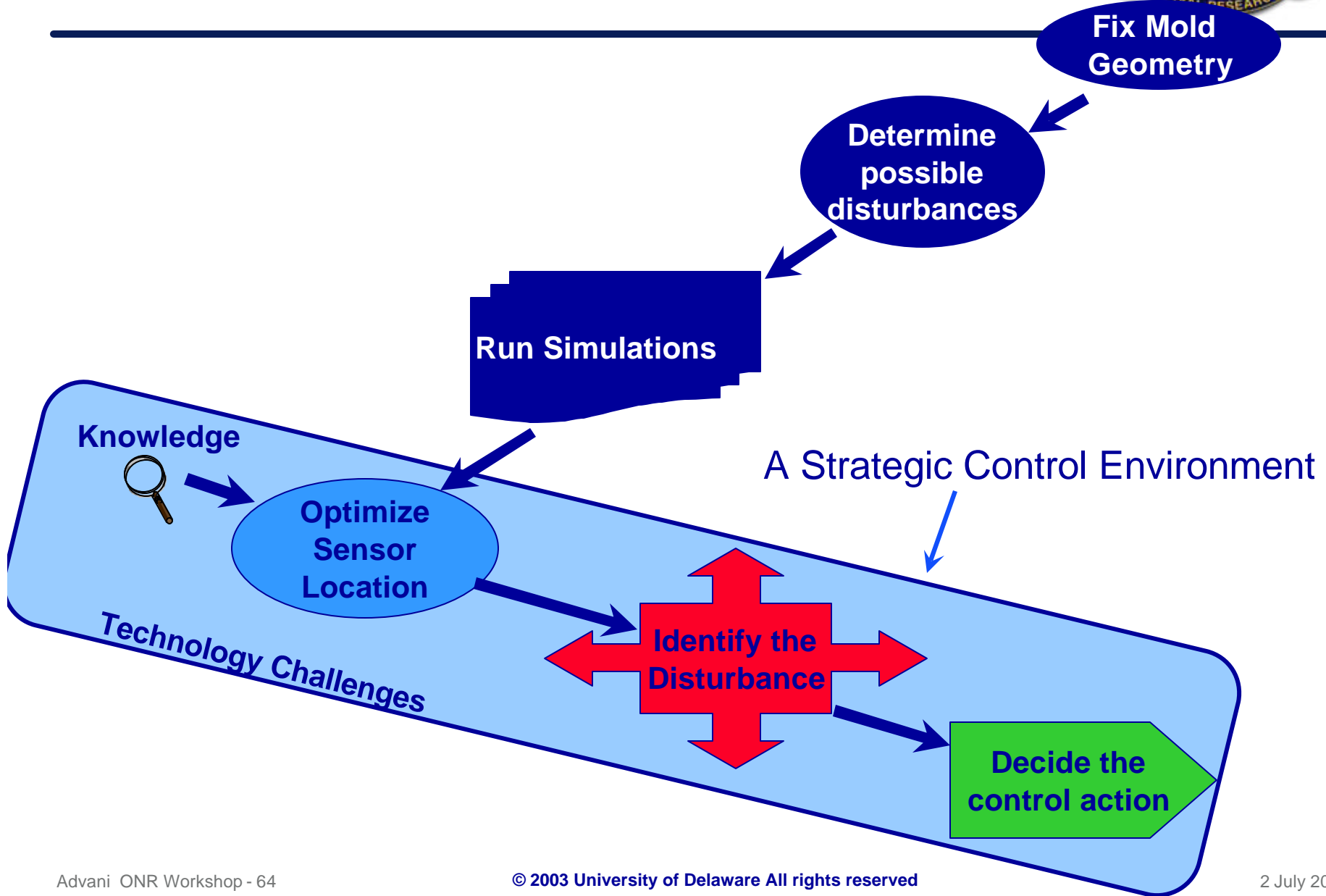

Sensors in Use

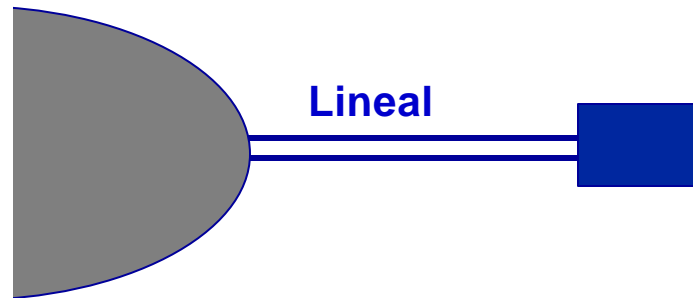

Point



Smart (Tekscan)

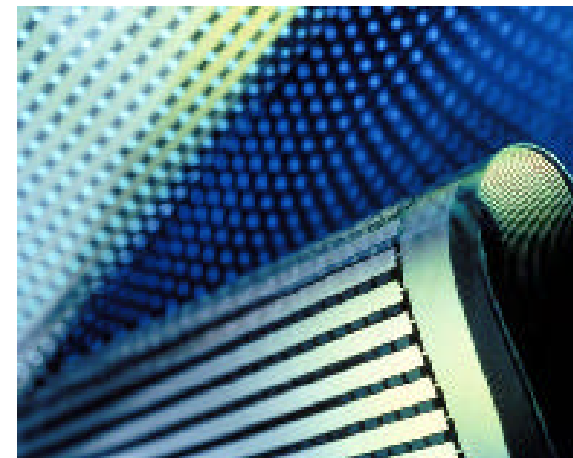

TekScan Sensor for Pressure and Flow Monitoring

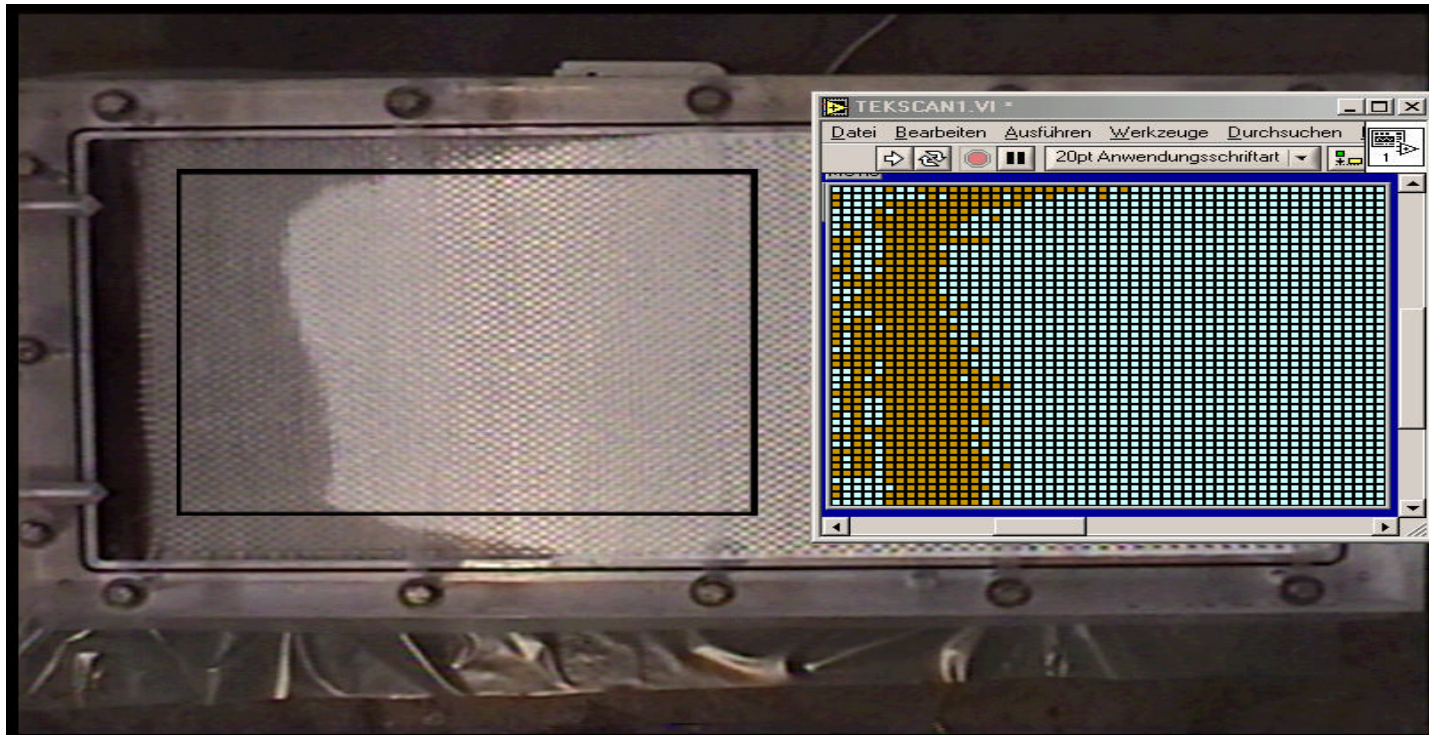

Comparison between the RTM-experiment (on the left) and the simulated flow front from the pressure information as obtained by the Tekscan sensor (on the right) at the same time step.

Detection and Characterization of Race-Tracking during Flow

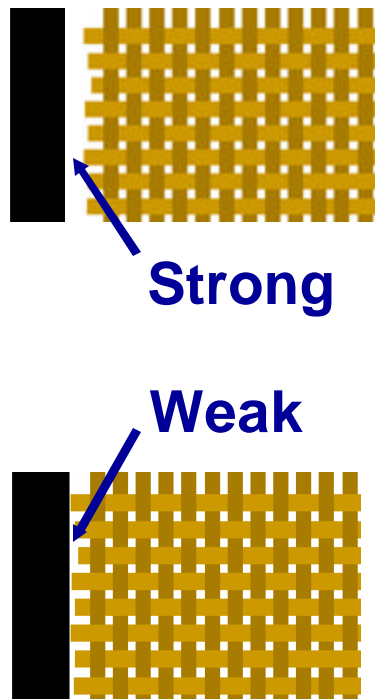

×

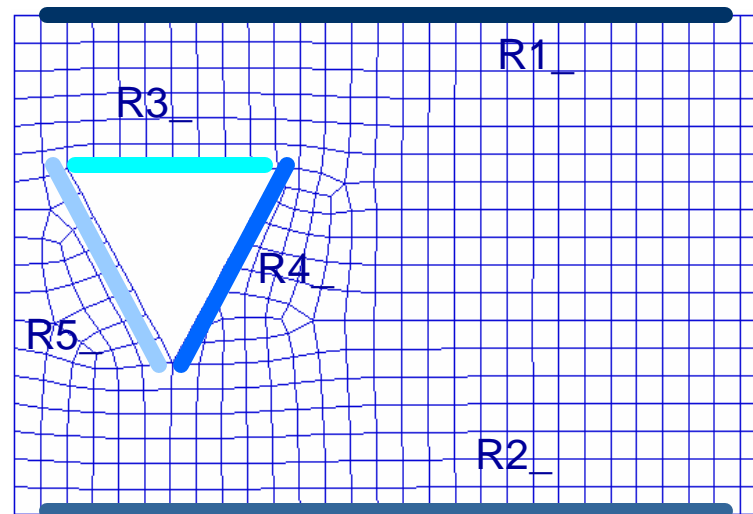

= 32 Cases
N = 2 ; P = 5

N levels of race-tracking

p regions where race-tracking is likely to occur

N^p possibilities

Approach to Create Disturbance Detection and Auxiliary Action Databases

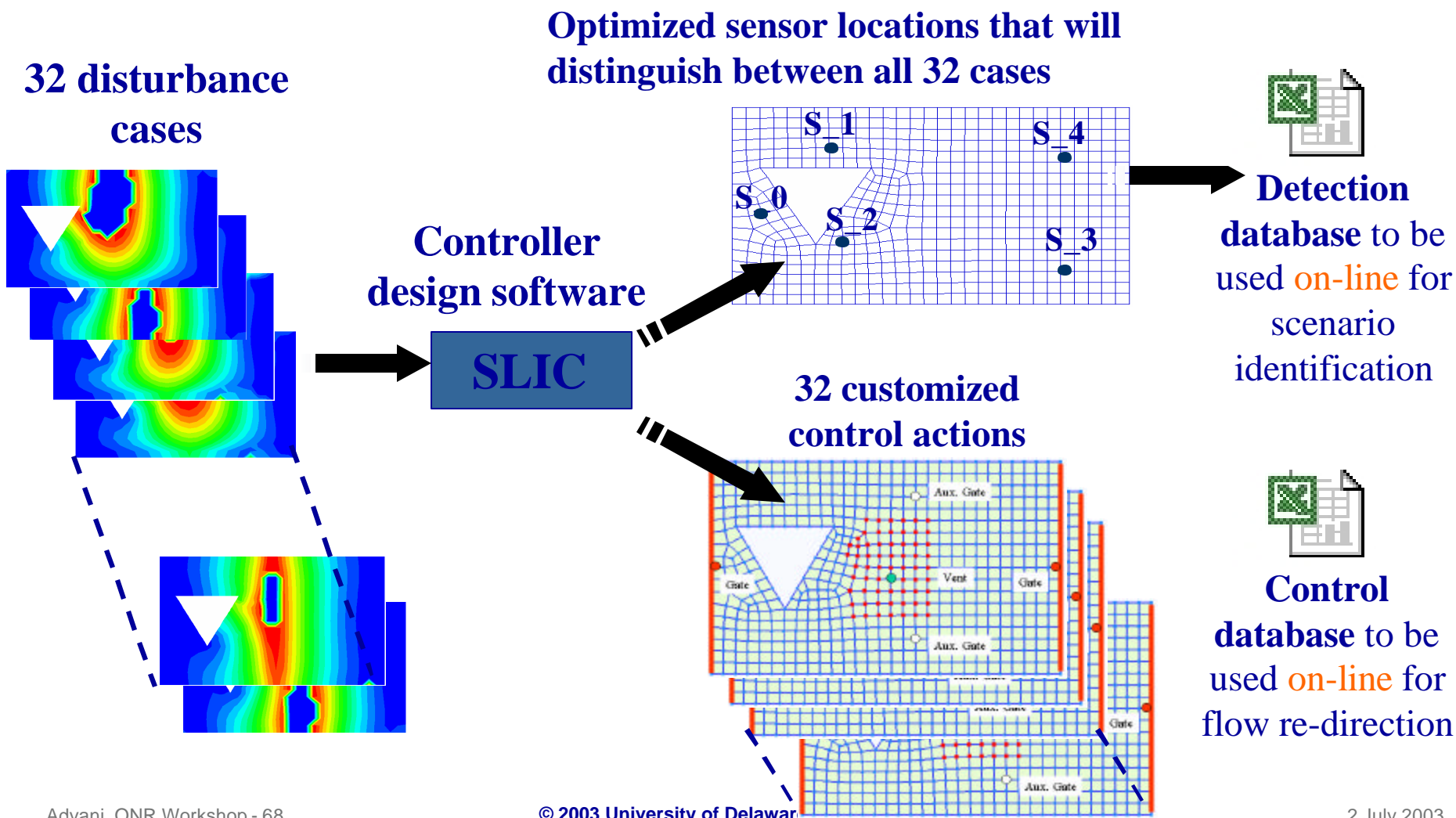

Active Control



NO ACTIVE CONTROL

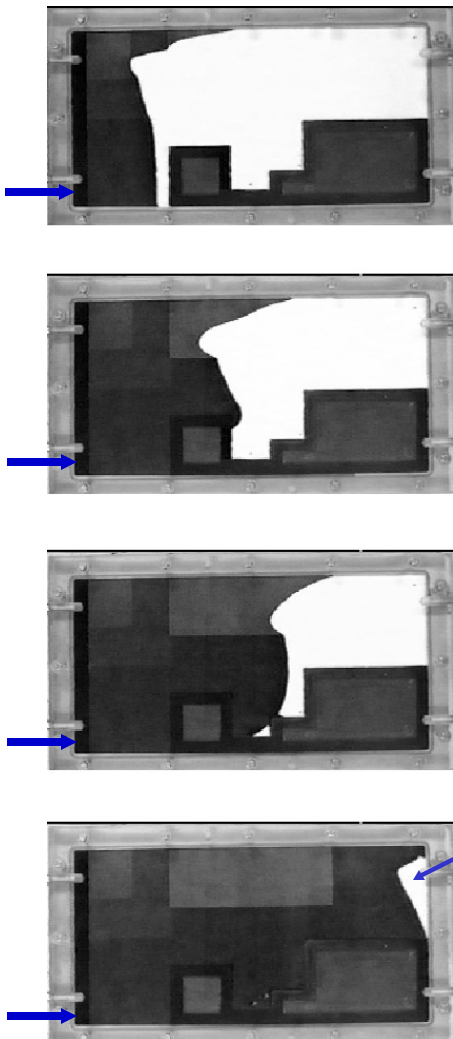

ACTIVE CONTROL

t = 40 s.

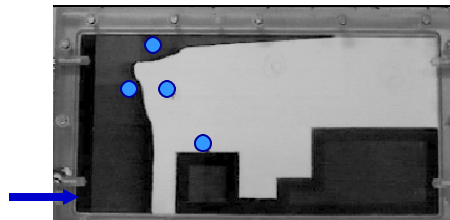

t = 80 s.

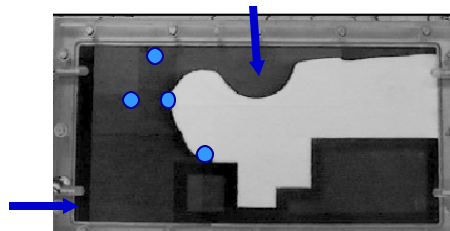

t = 120 s.

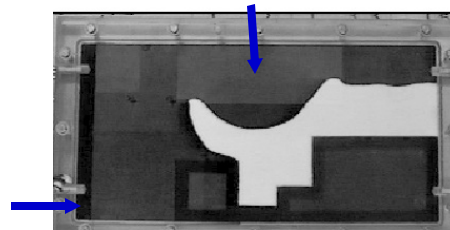

end of exp.

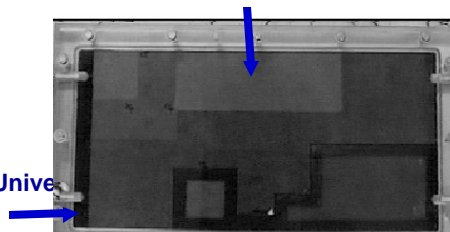

Dry spot

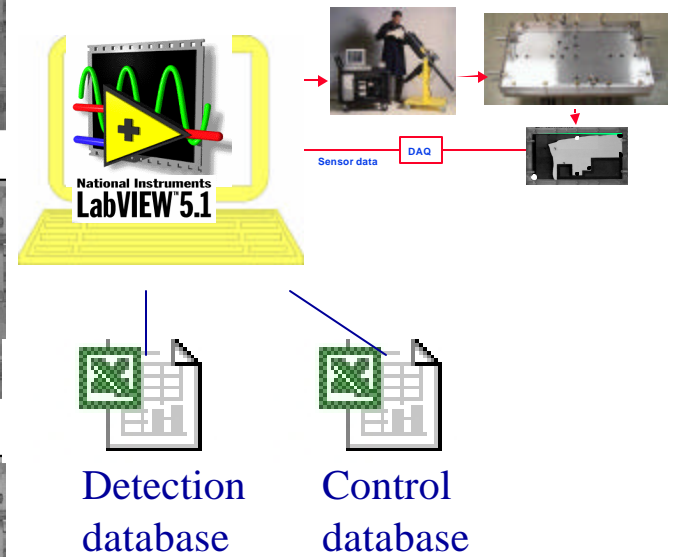

Implementation and Experimental Validation

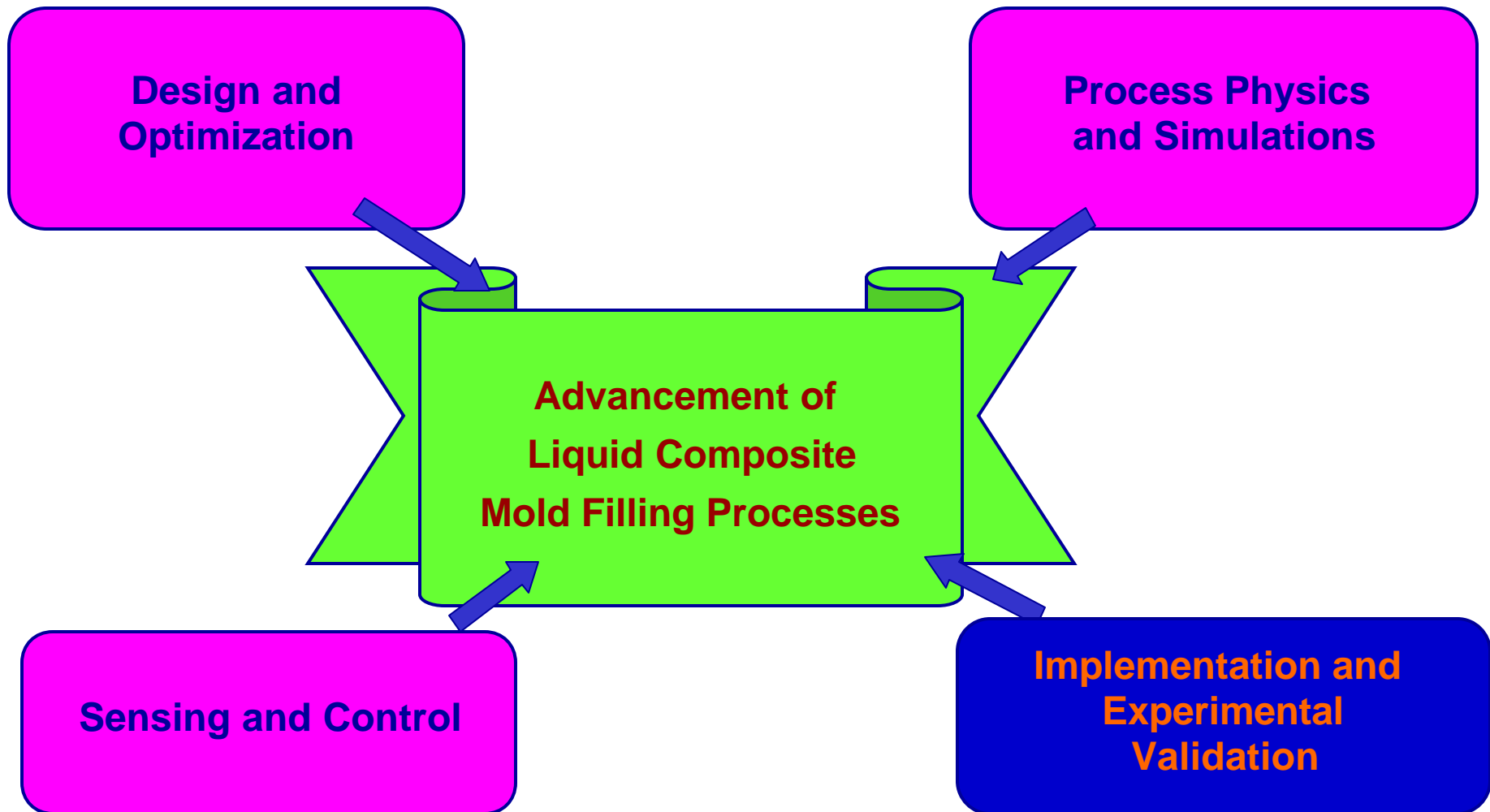

Software and Hardware Integration

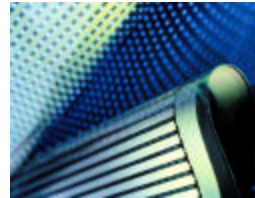

Flow Sensors

Teskscan pressure grid



Auto RTM

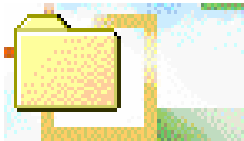
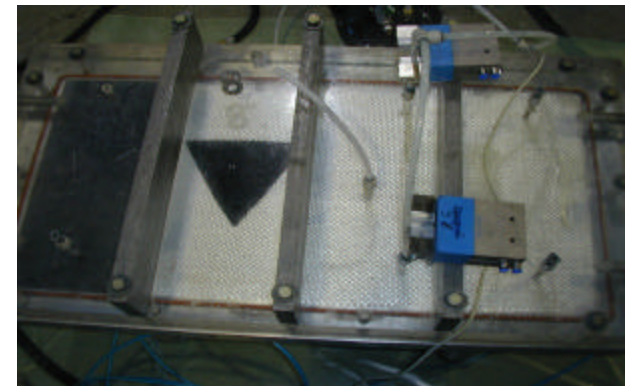

Controller data file.1-
Detection and control action databases

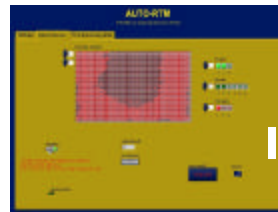

Select a pre-defined scenario that represent the ongoing experiment.

- Implement the customized control action



Injection machine

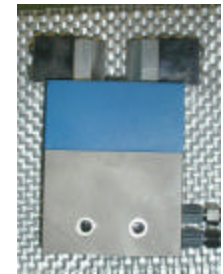

Actuators

Active Control Methodology

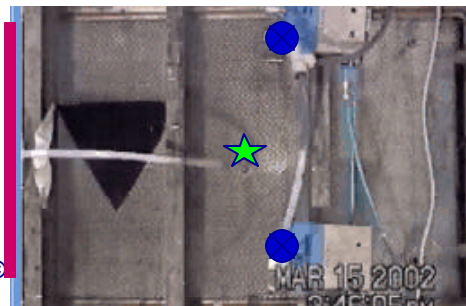
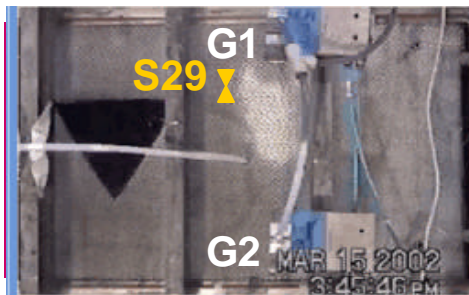
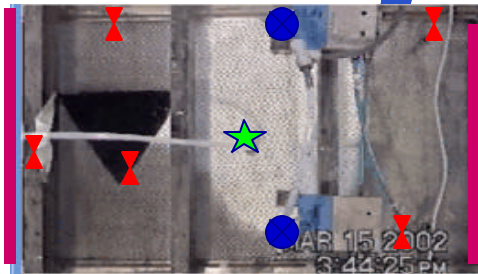
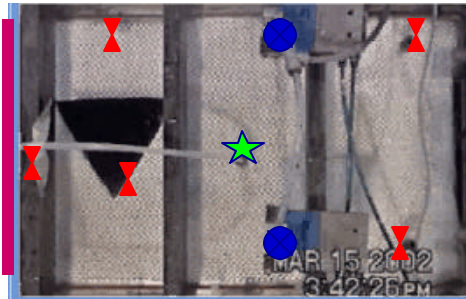

Detection database

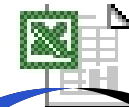

Control action database

Experimental resin arrival times t_1, t_2, t_3, t_4, t_5 are reported

Scenario 29 is selected

Customized control action for case 29

⚠ Flow sensors for control action

Control action is to open Gate G1 when resin arrives at the flow sensor S29.

Successful injection

Initial injection lines —

Fixed vent ★

Control gates ●

Flow sensors for identification ⚠

Post Analysis and Flow Simulation Validation



Simulation 29
was selected
during injection

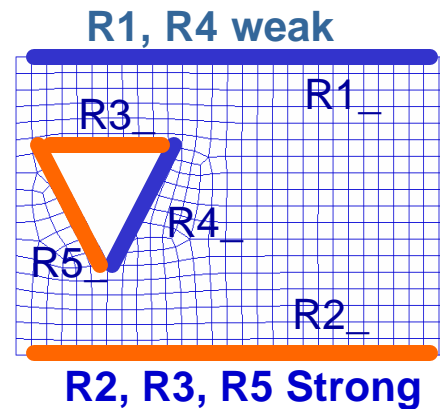

**Customized control
action for the
selected disturbance
Was automatically
implemented**



Result Without Control Action



Case 29 without control action

Flow Advancement Verification: Tapered Mold

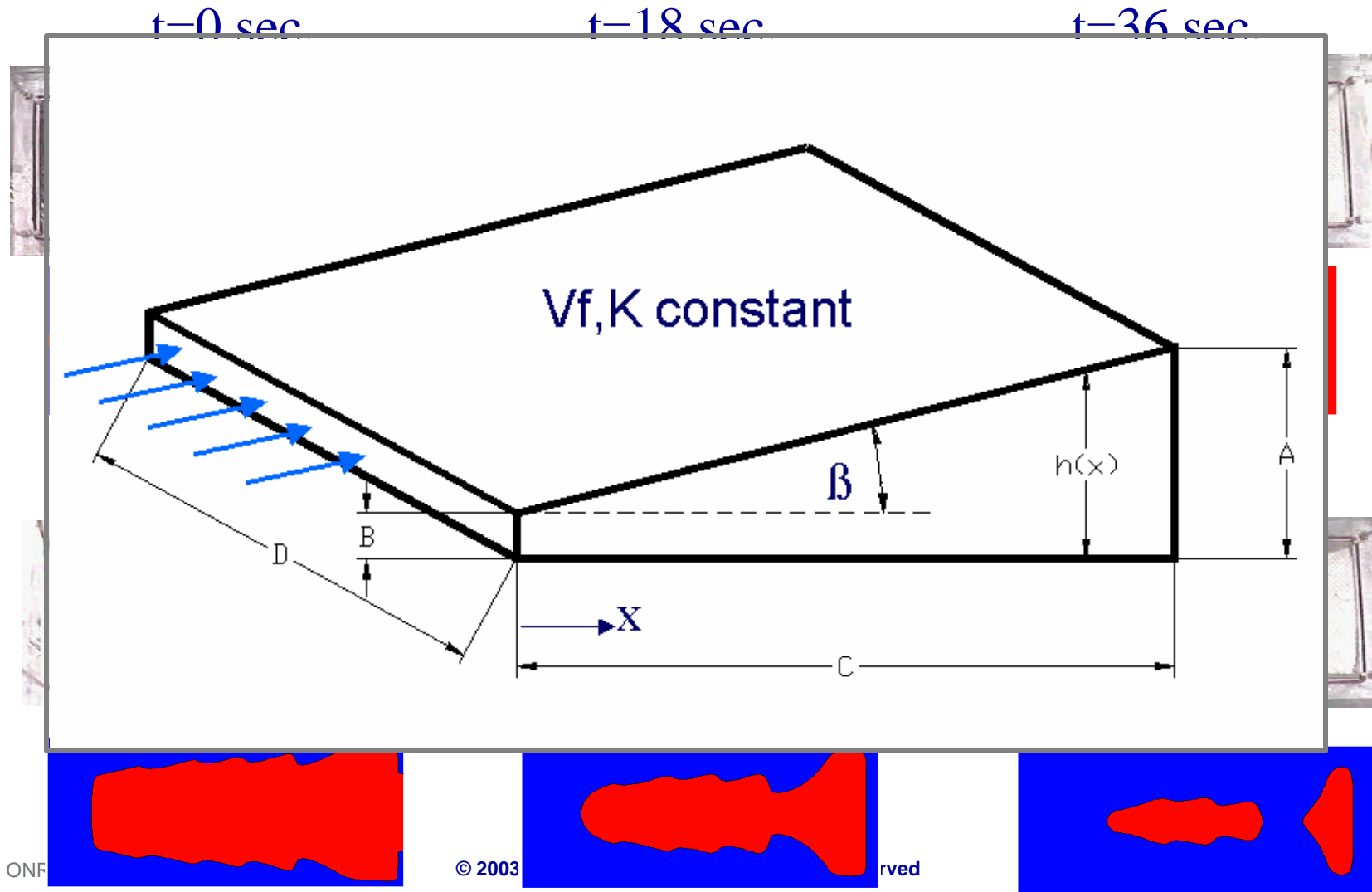

Verification: Race Tracking along Bottom Edge



t=0 sec.



t=30 sec.

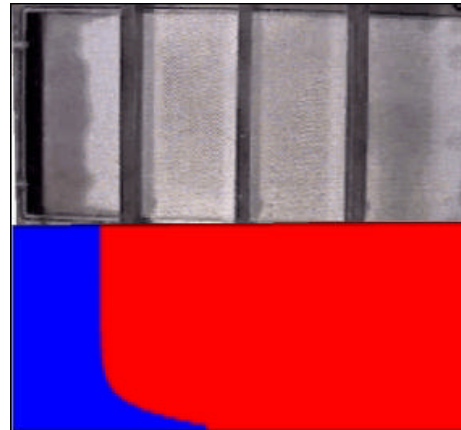

t=60 sec.

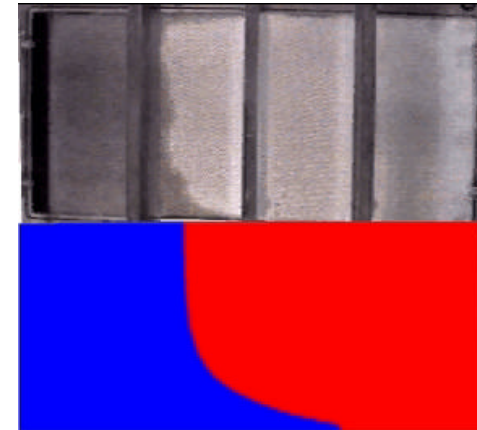

t=90 sec.

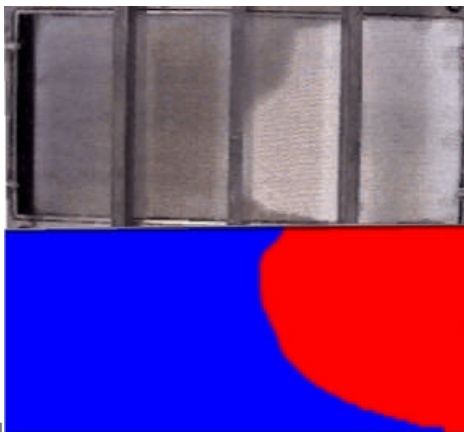

t=120 sec.

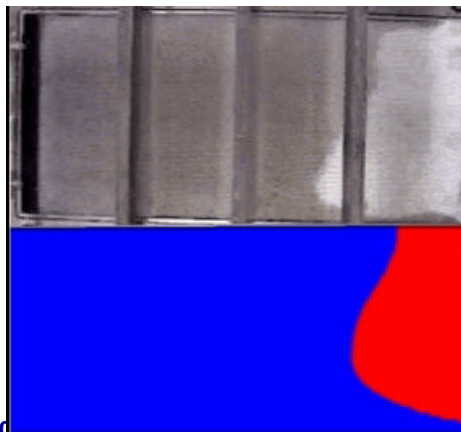

t=150 sec.

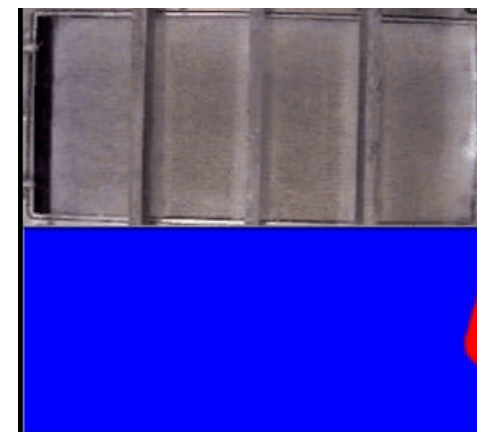

Flow Verification: Bus Mold



Pad-up Configuration

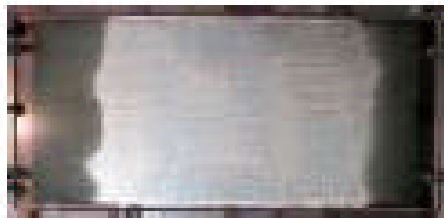
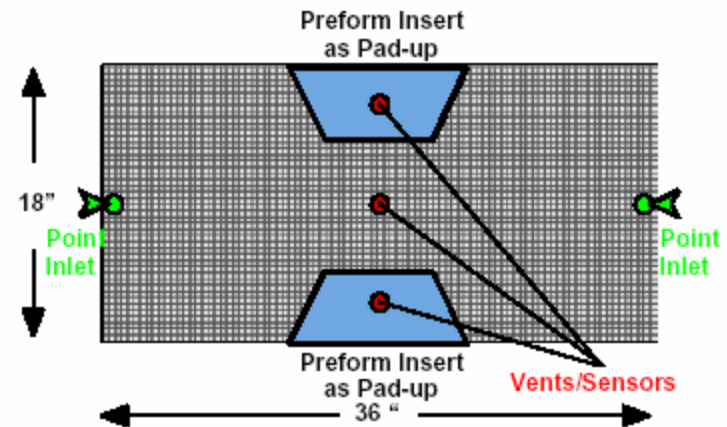
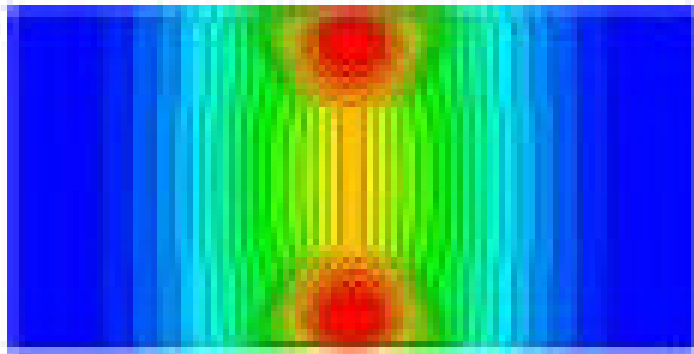

t = 15 s

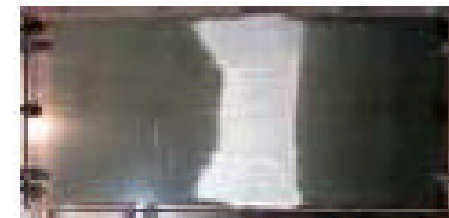

t = 75 s

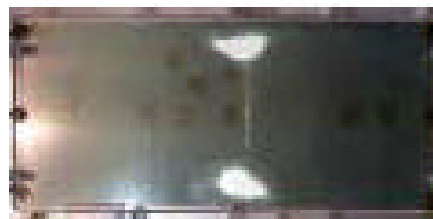

t = 135 s

Low Fiber Volume Fraction on the Left

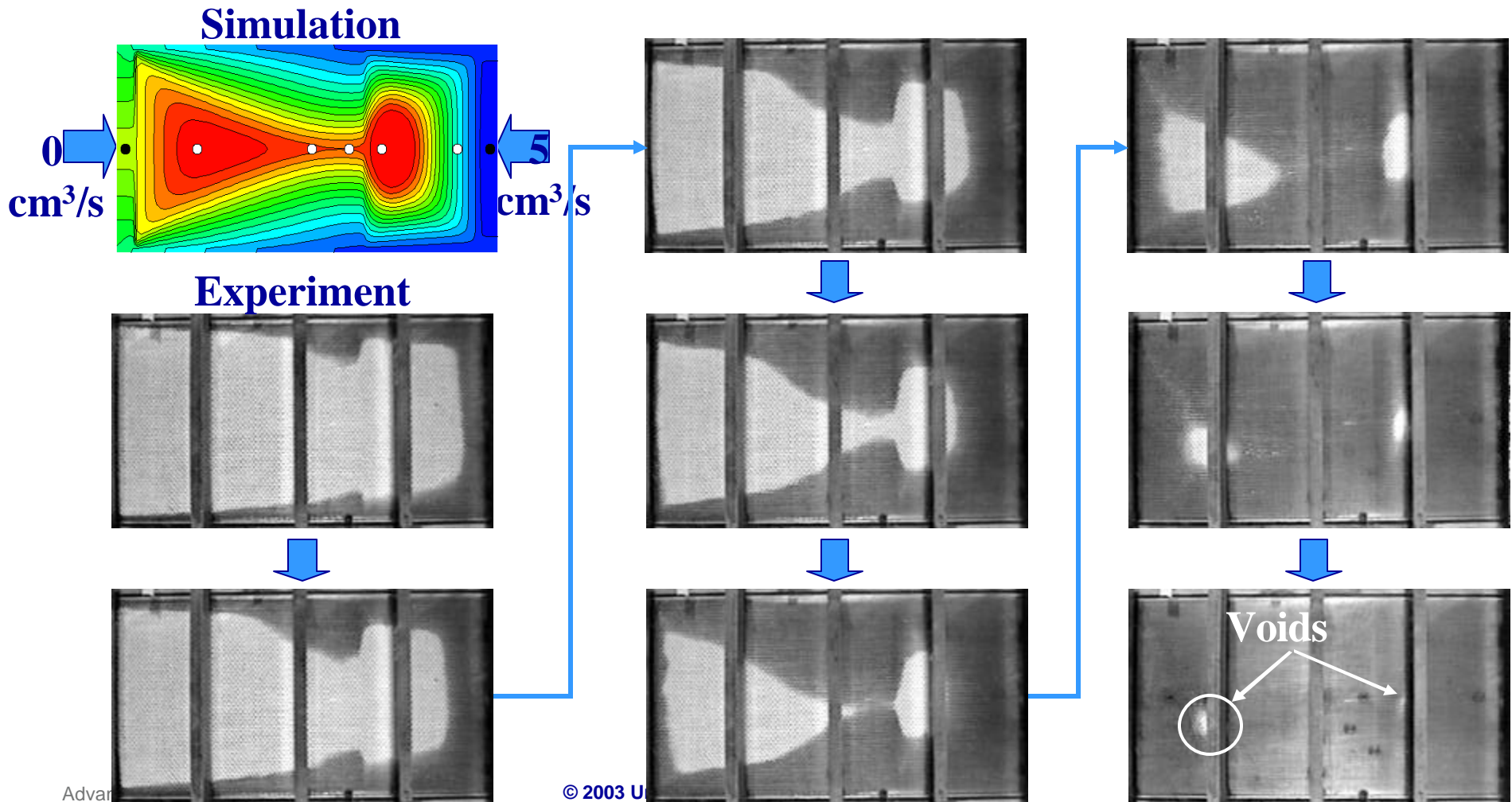

Verification: Changing Fiber Volume Fraction

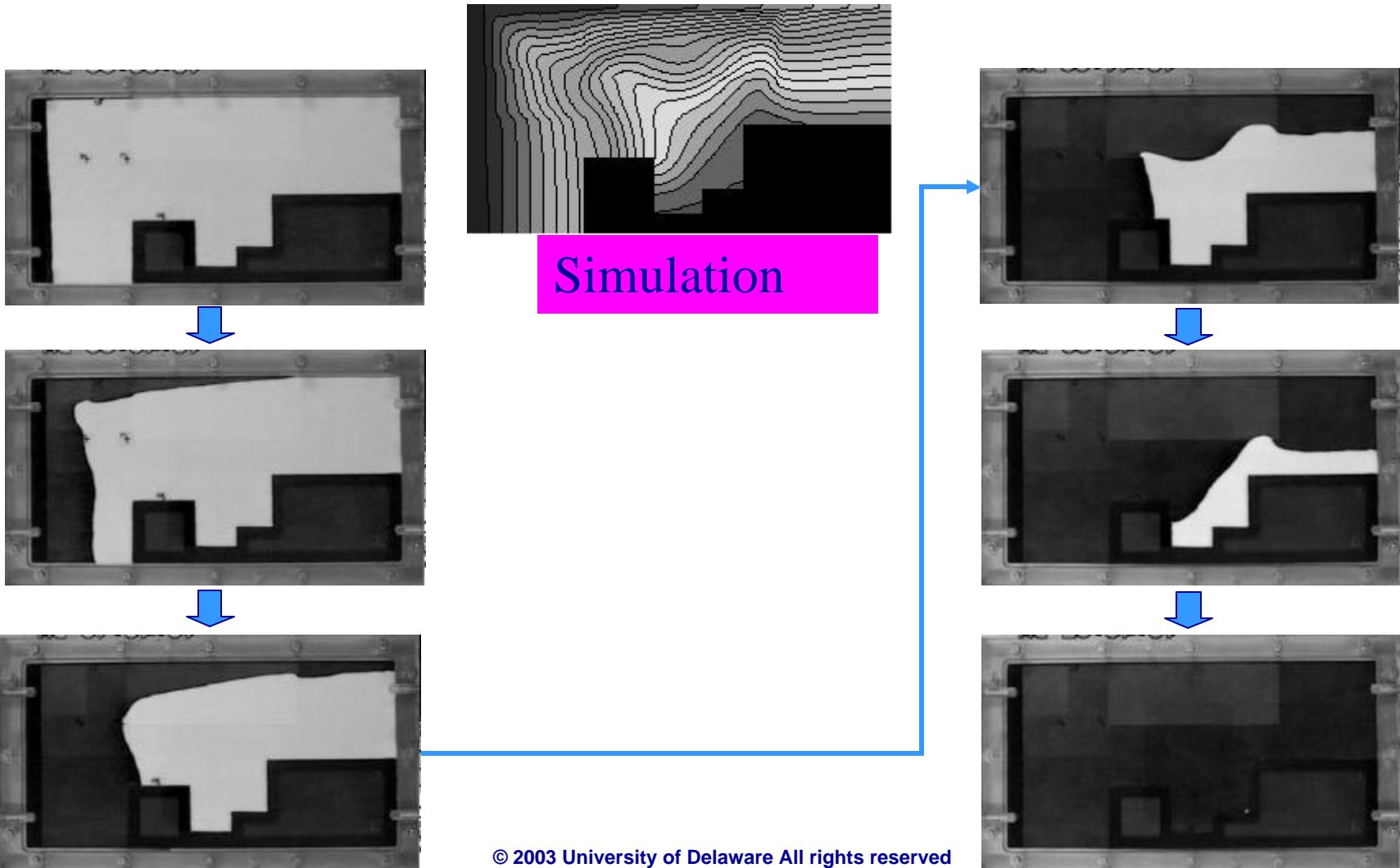

Active Control in a Complex Geometry



Mold Design

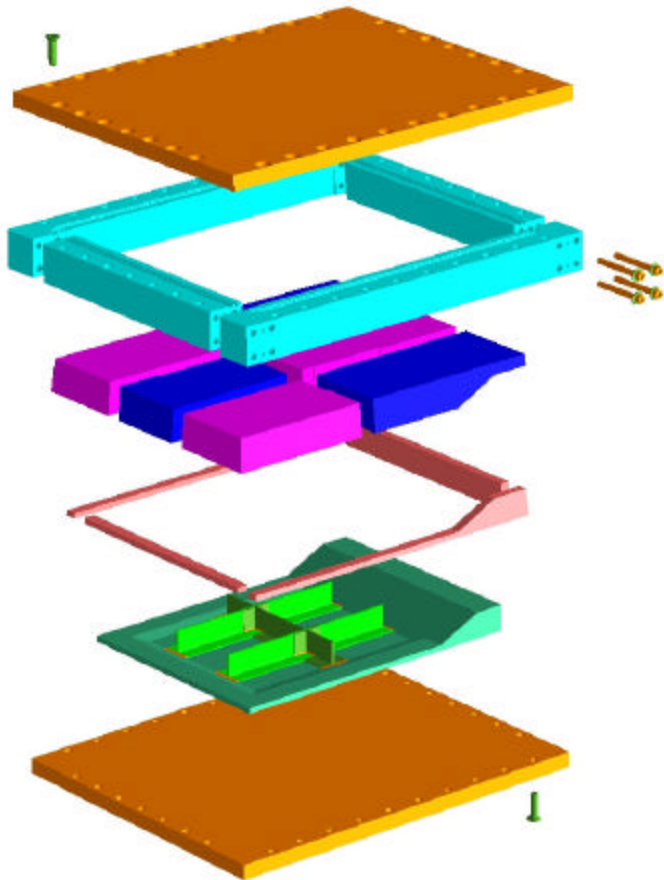

Exploded Solid Model

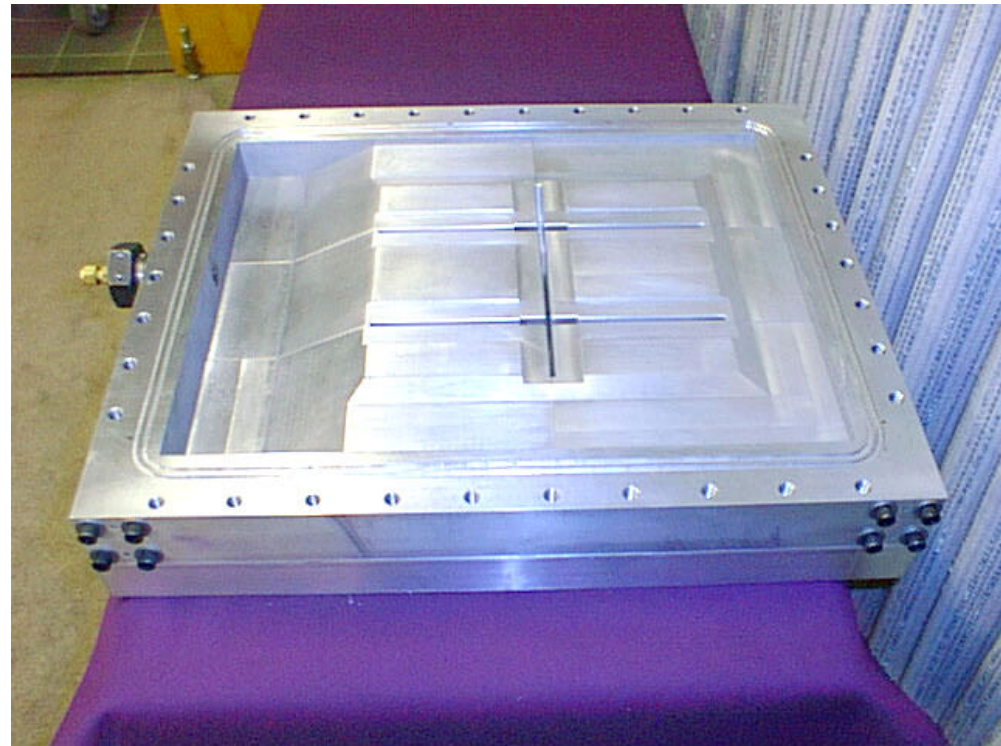

Assembled Lower Mold Platen

Preform Preparation

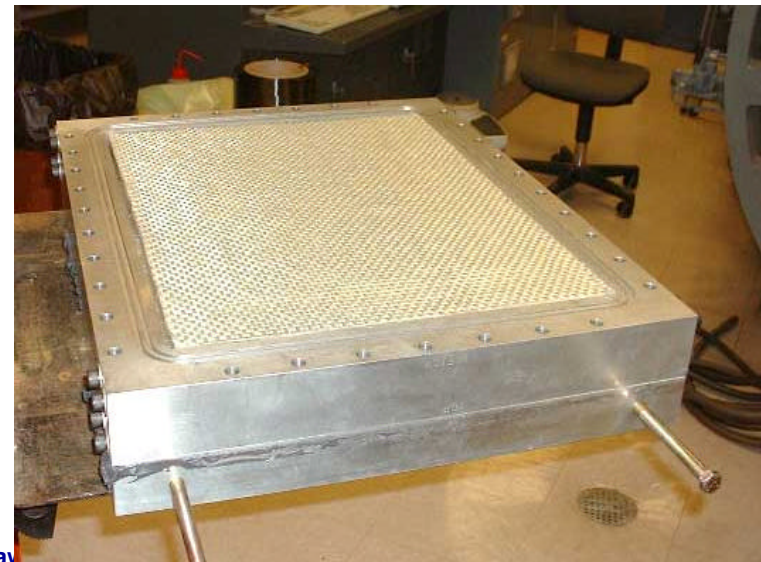
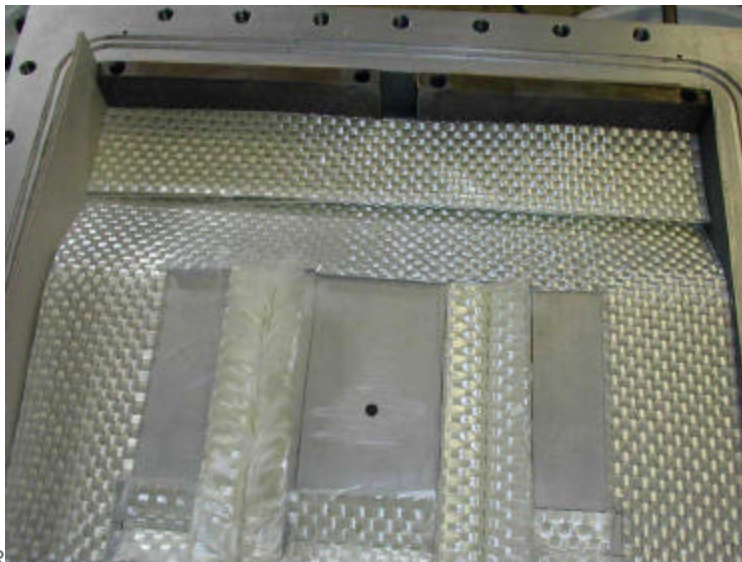
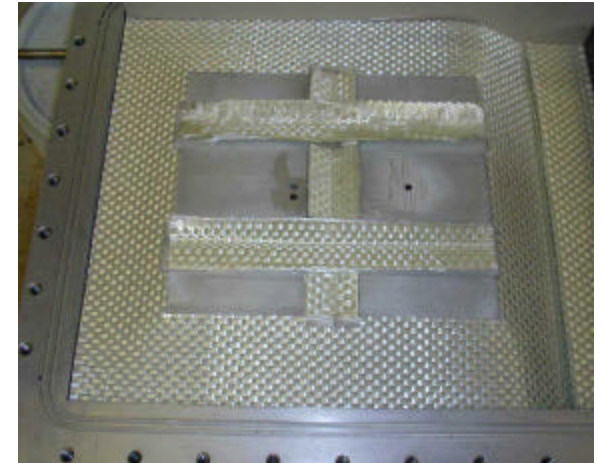
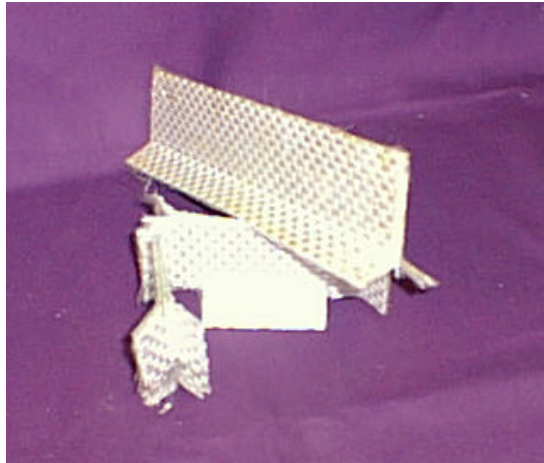

Detection and Control Action

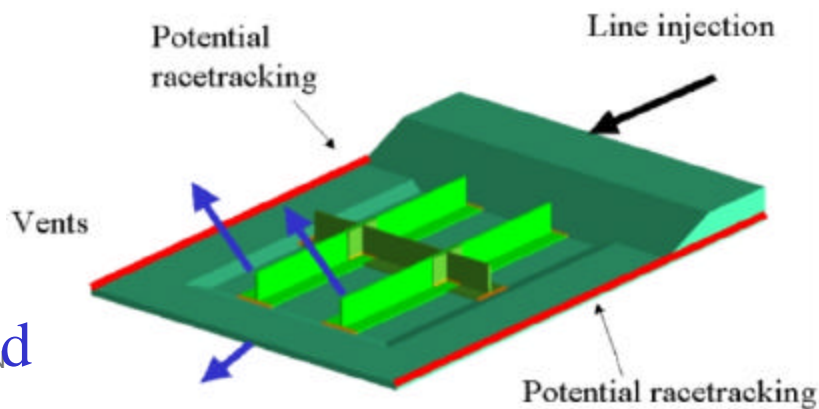
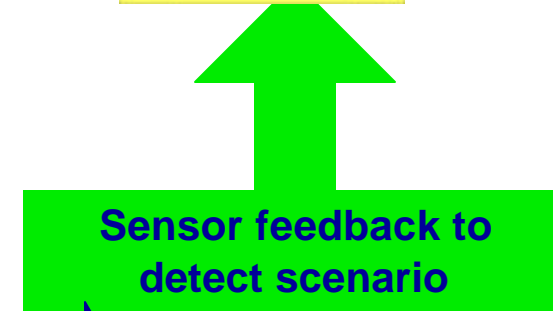
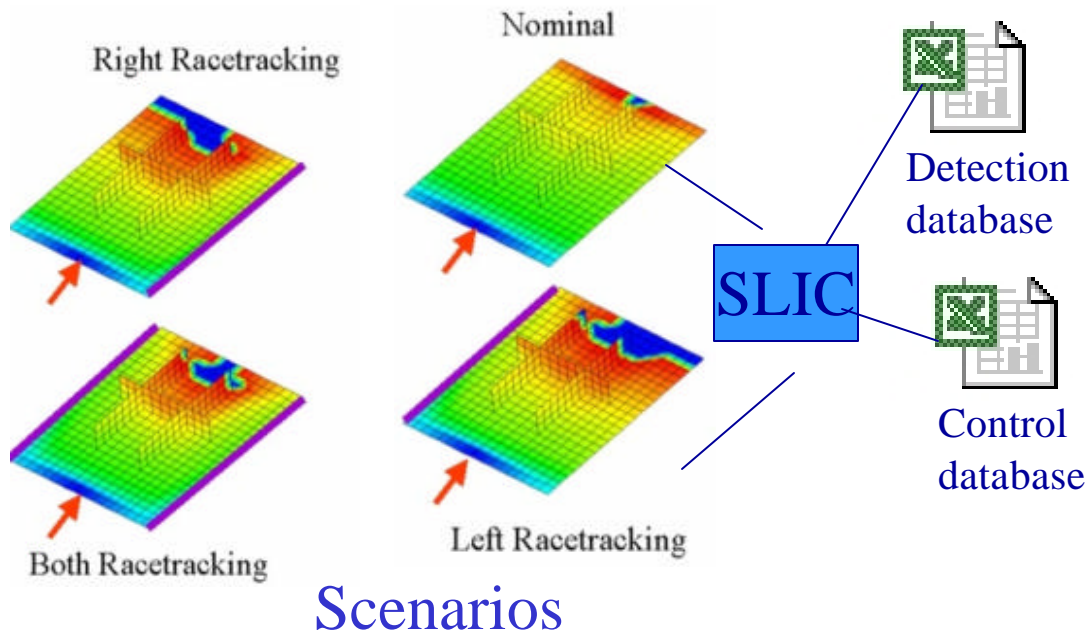

Mold



are All

B

Left Side Racetracking – No Control



Filling Simulation:

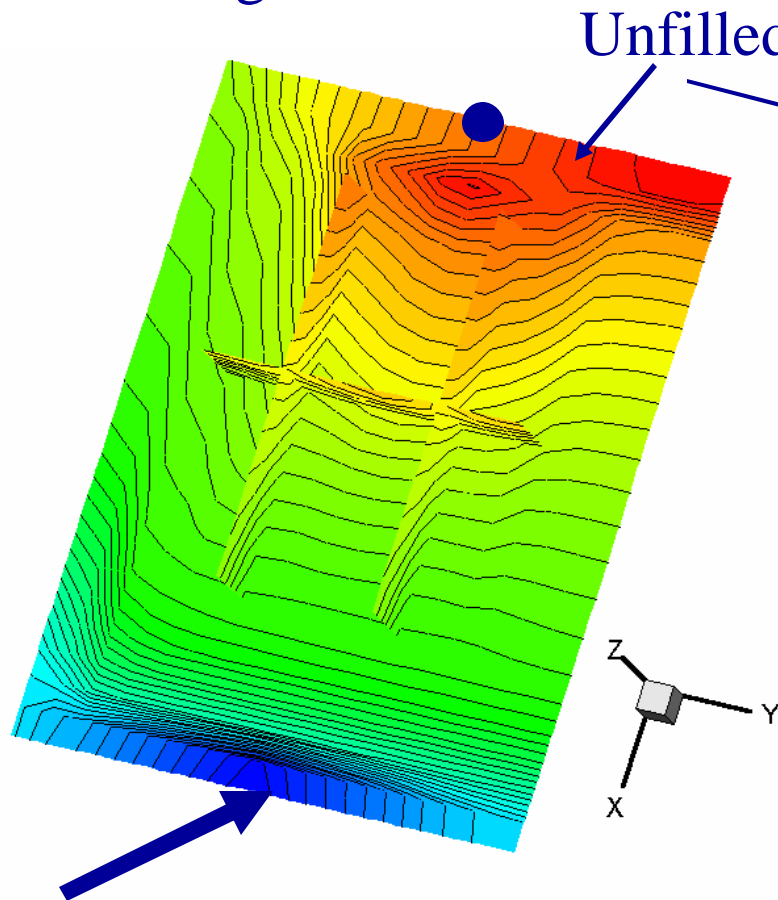

Manufactured Part:

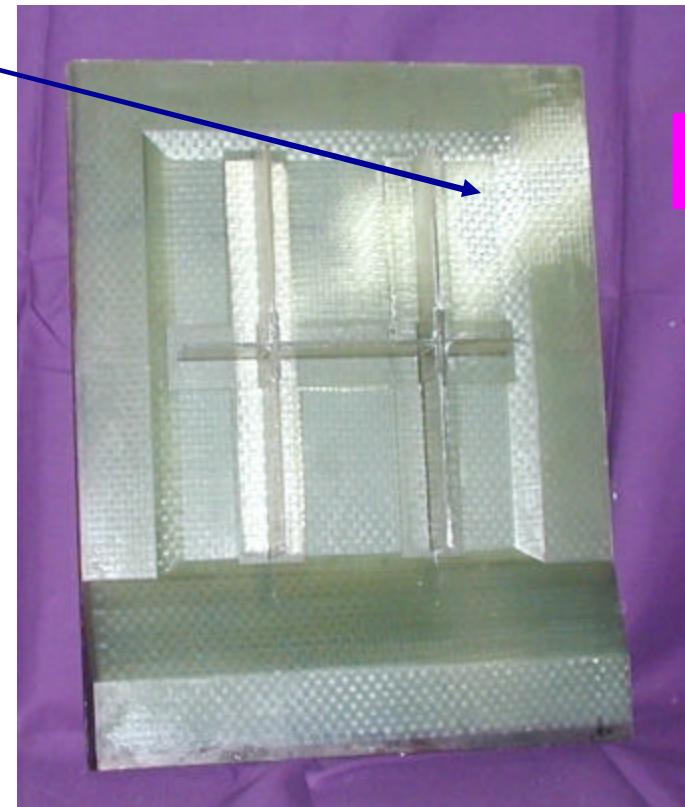

Void

Inject with $Q = Q_0$

Left Racetracking - Control



Filling Simulation:

Manufactured Part:

When racetrack
inject:

#0: 0.0

#1: Q_0

#2: $1/3 Q_0$

#3: 0.0

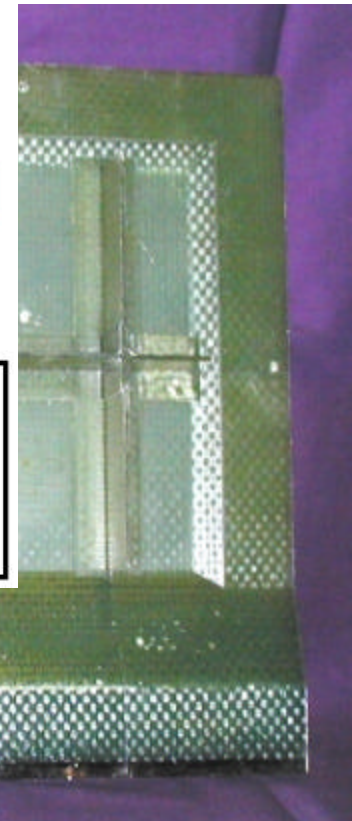
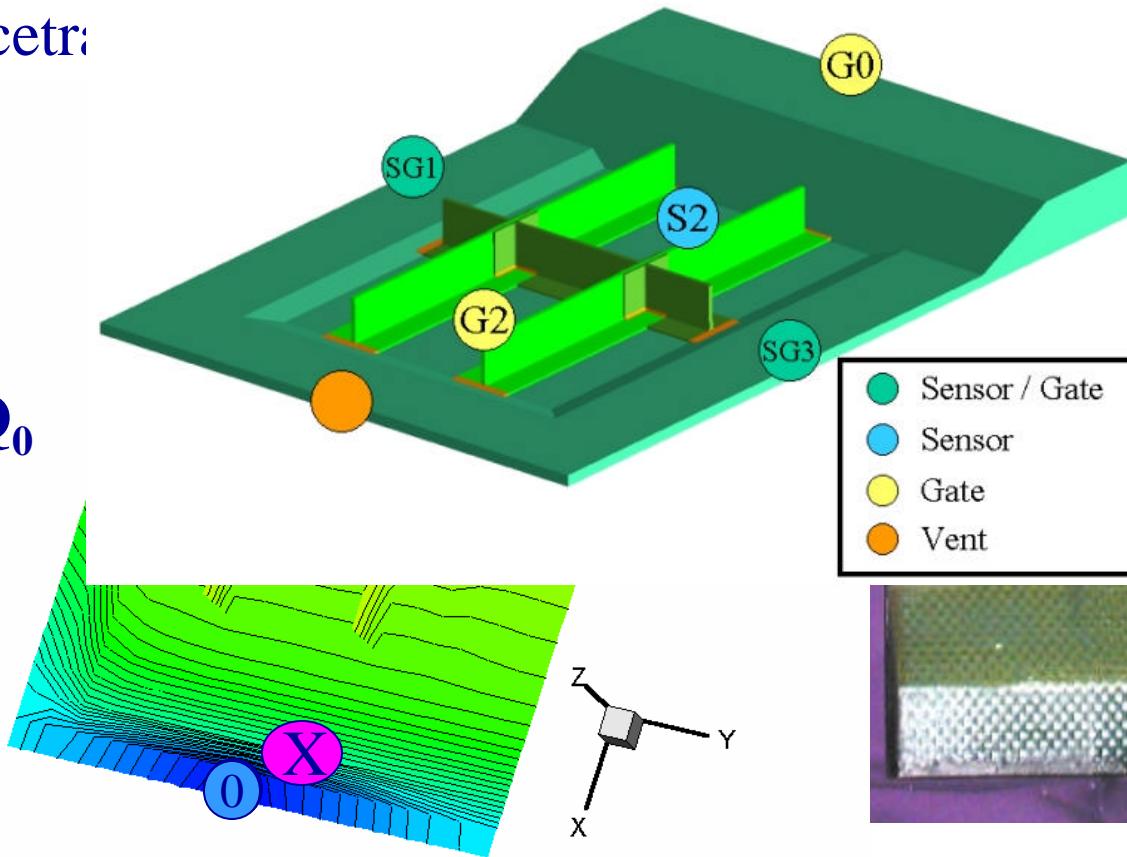

Objective



The objective is to build a modular RTM Workstation that can be used to manufacture various part geometries as well as provide flow control and sensing over the resin filling stage to ensure properly filled parts in the case of flow disturbances.

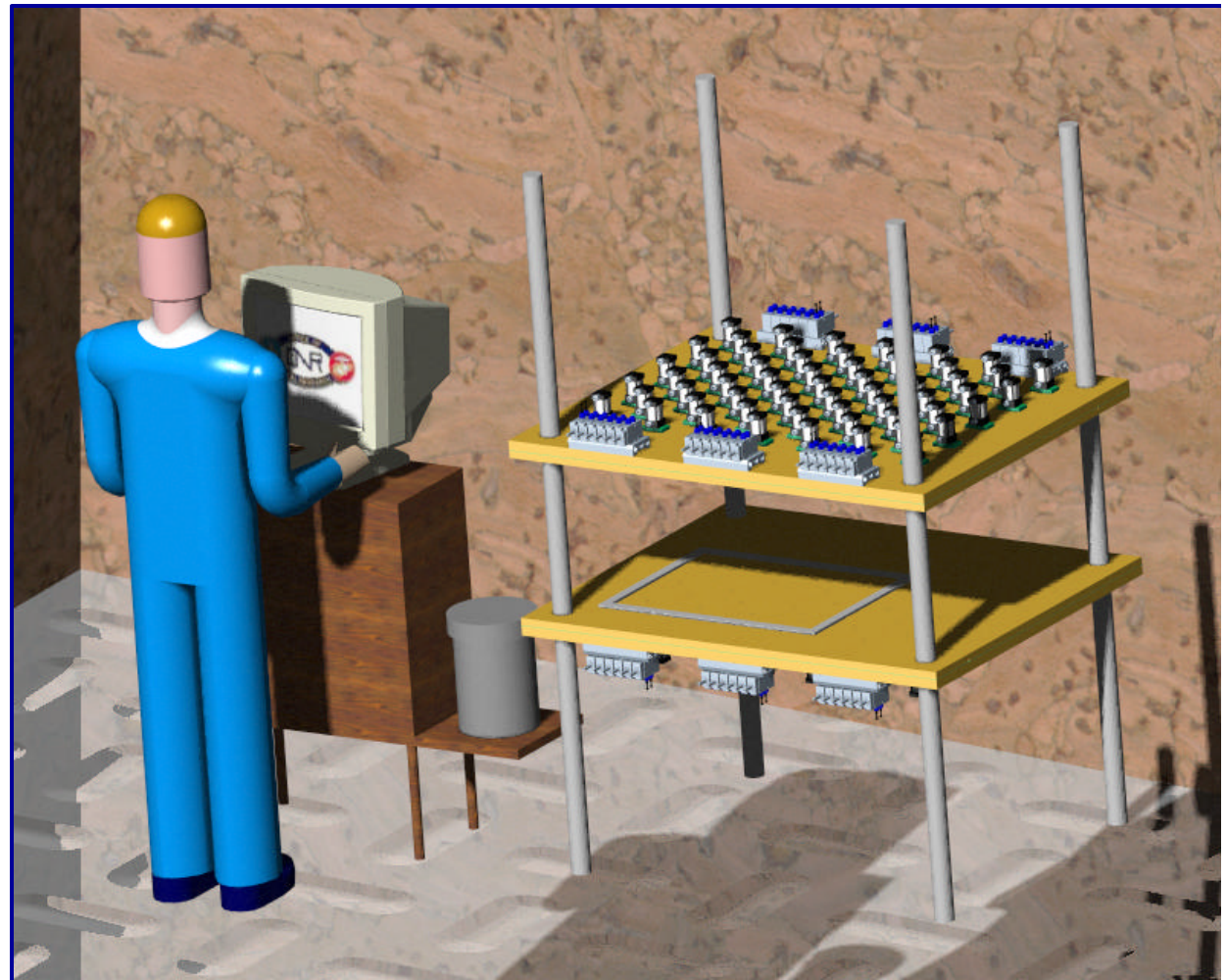

Motivation

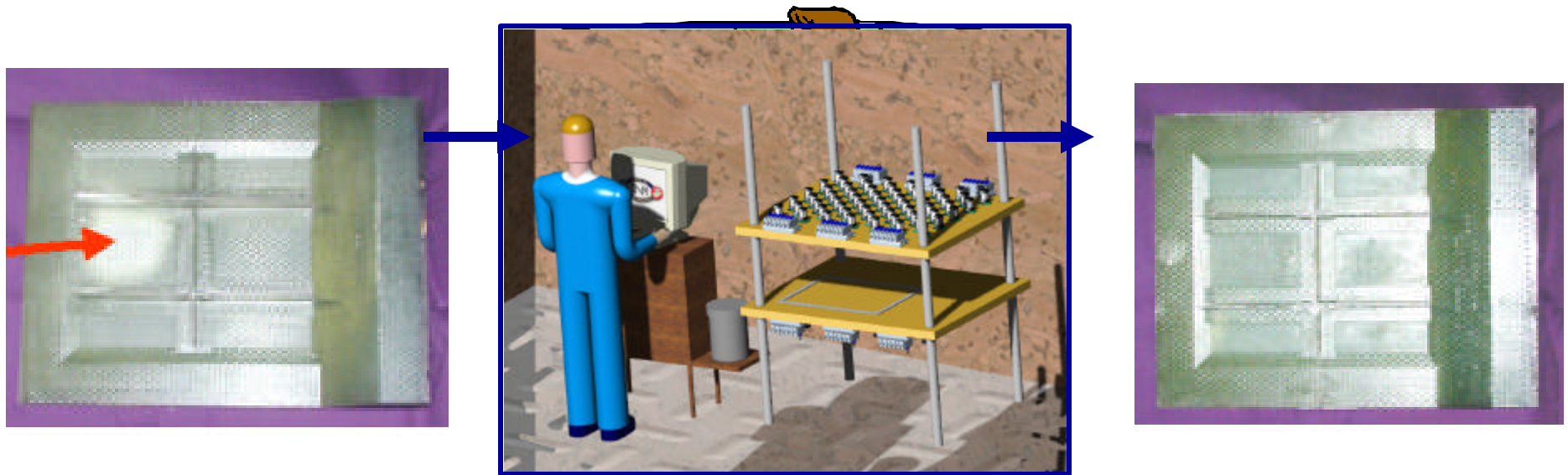

There is a need to have better control of the filling stage to ensure part quality and increase yield of production.

Mold Frame Work



The basic mold framework would consist of top and bottom plates, which can be opened and closed via a hydraulic system.

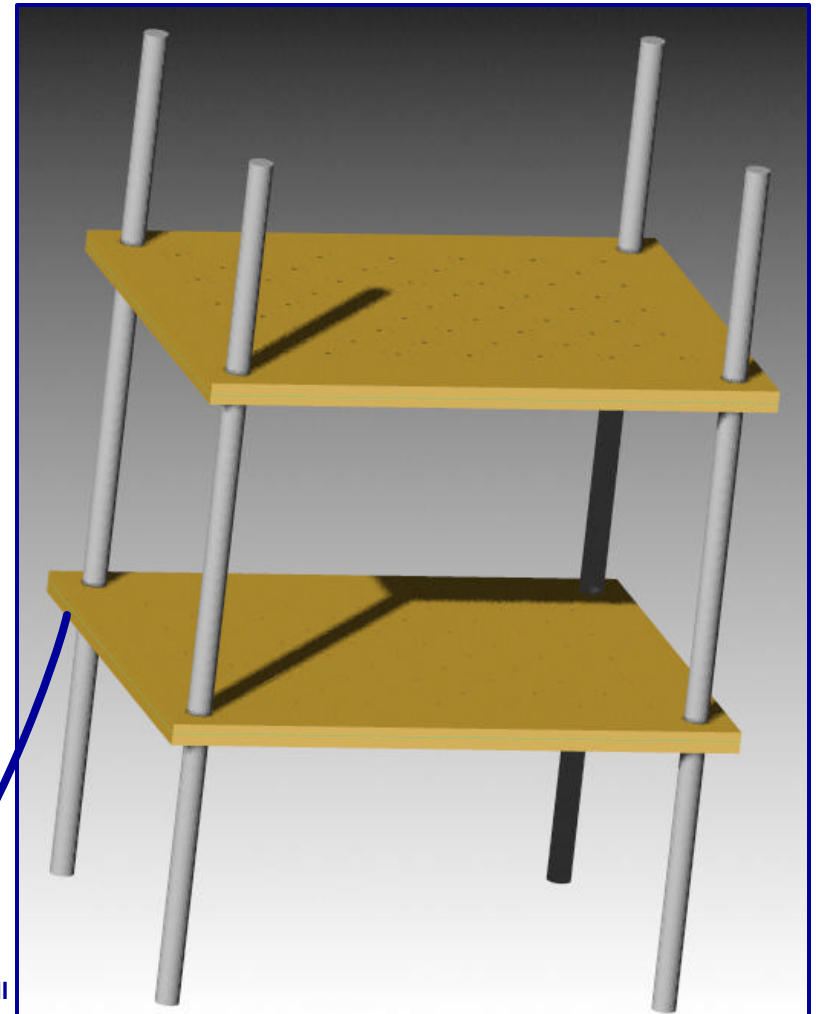

Modular Frame Work

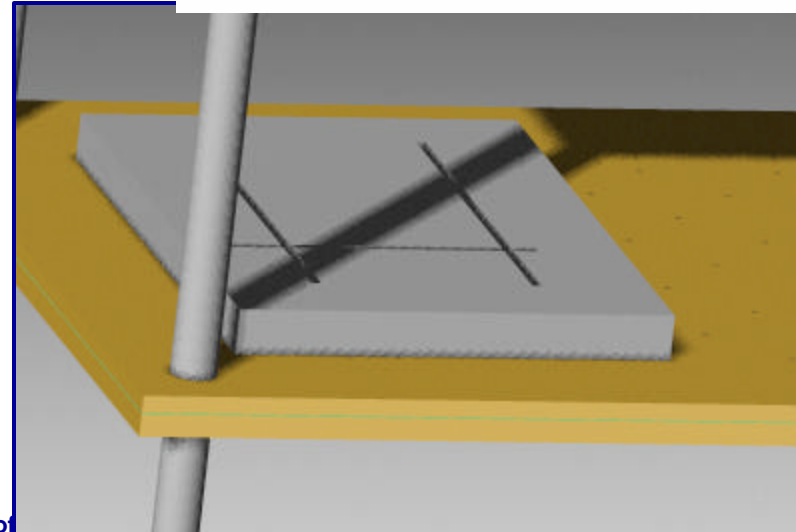
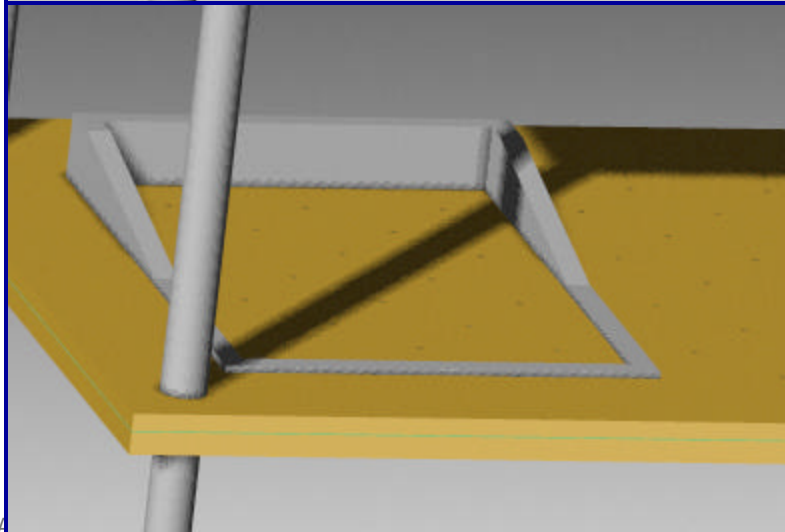
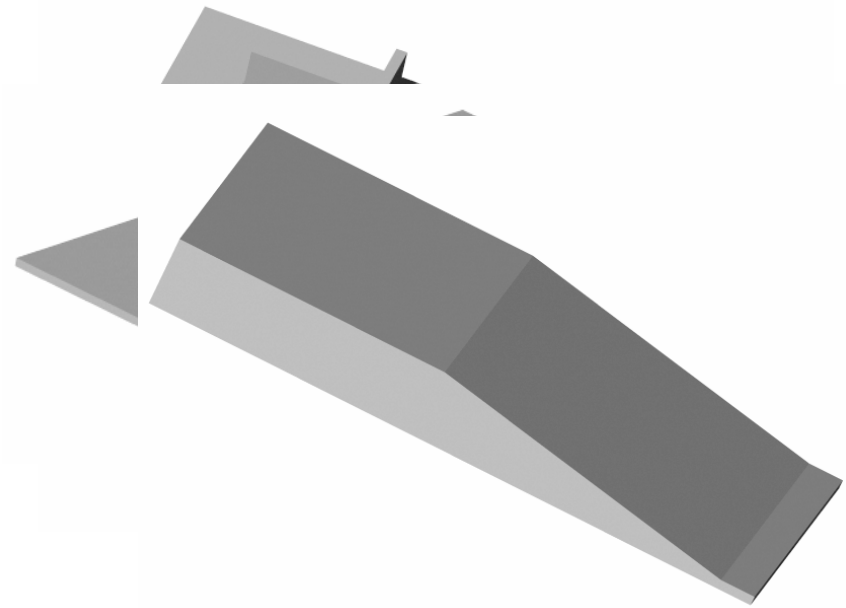
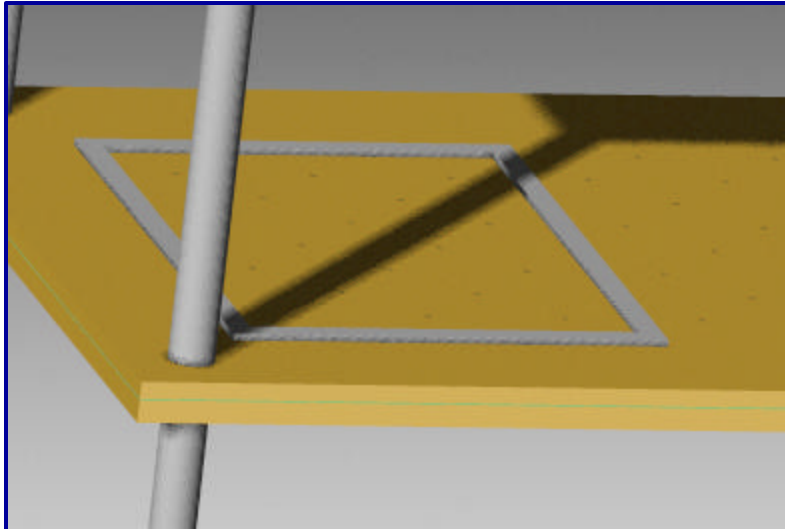

ity of

2 July 2003

Multiple Injection System

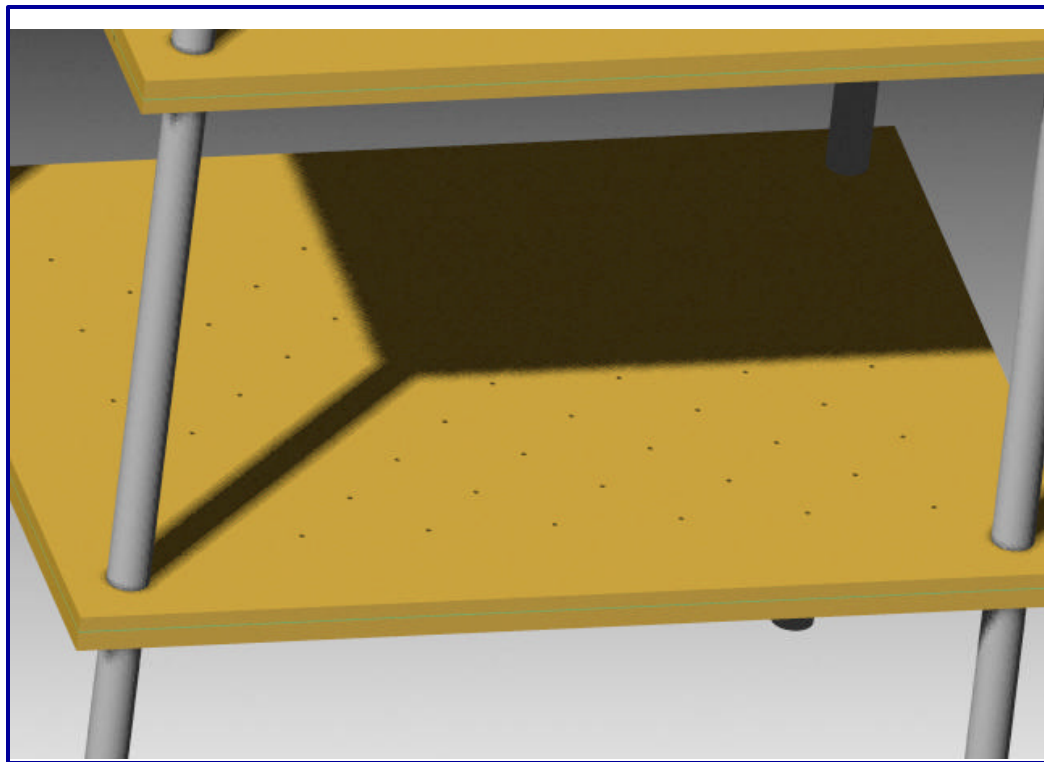

Potential injection locations will be distributed all over the mold surface, to further accommodate various part geometries as well as provide the opportunity for flow control ...

New Injection Method



A channel-based injection will eliminate the waste associated with the tubing

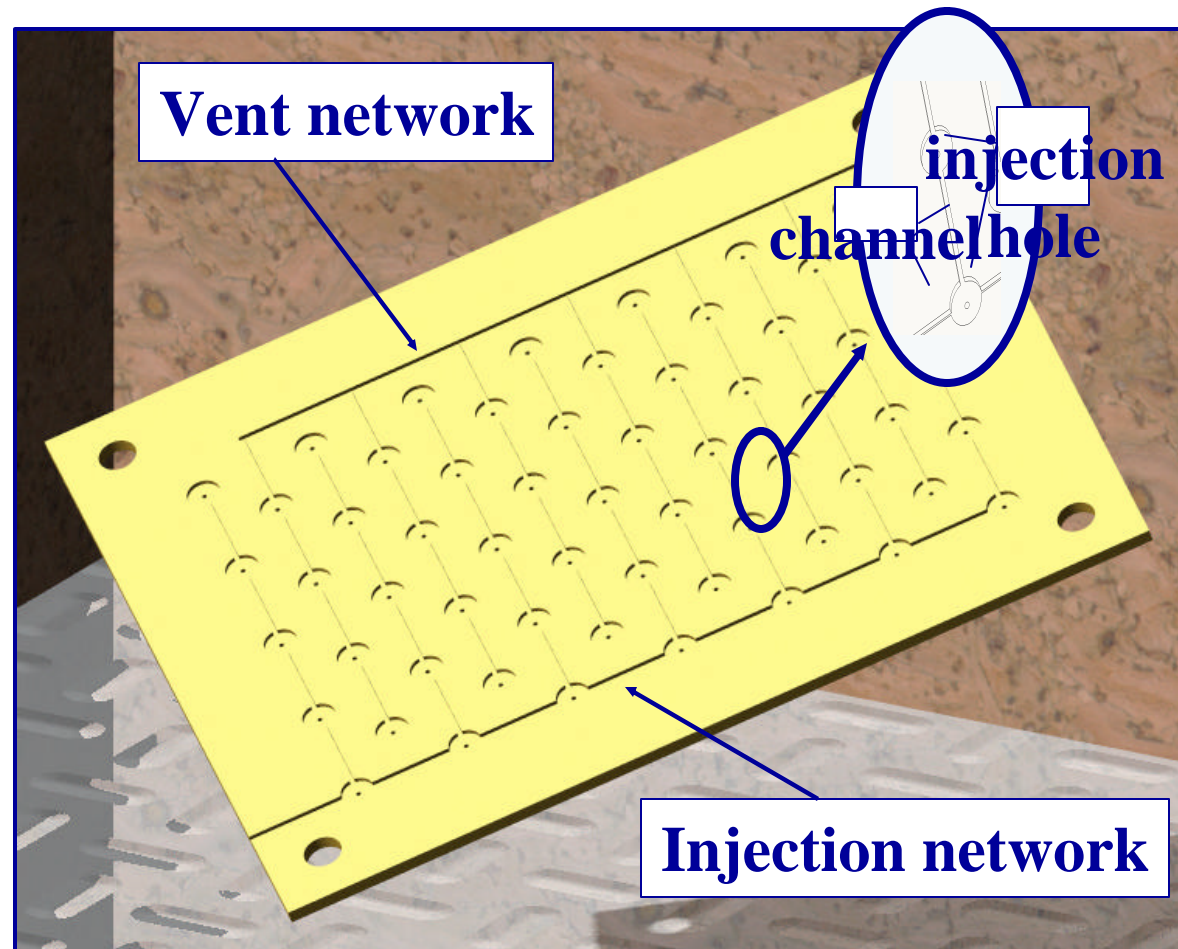

Piston System

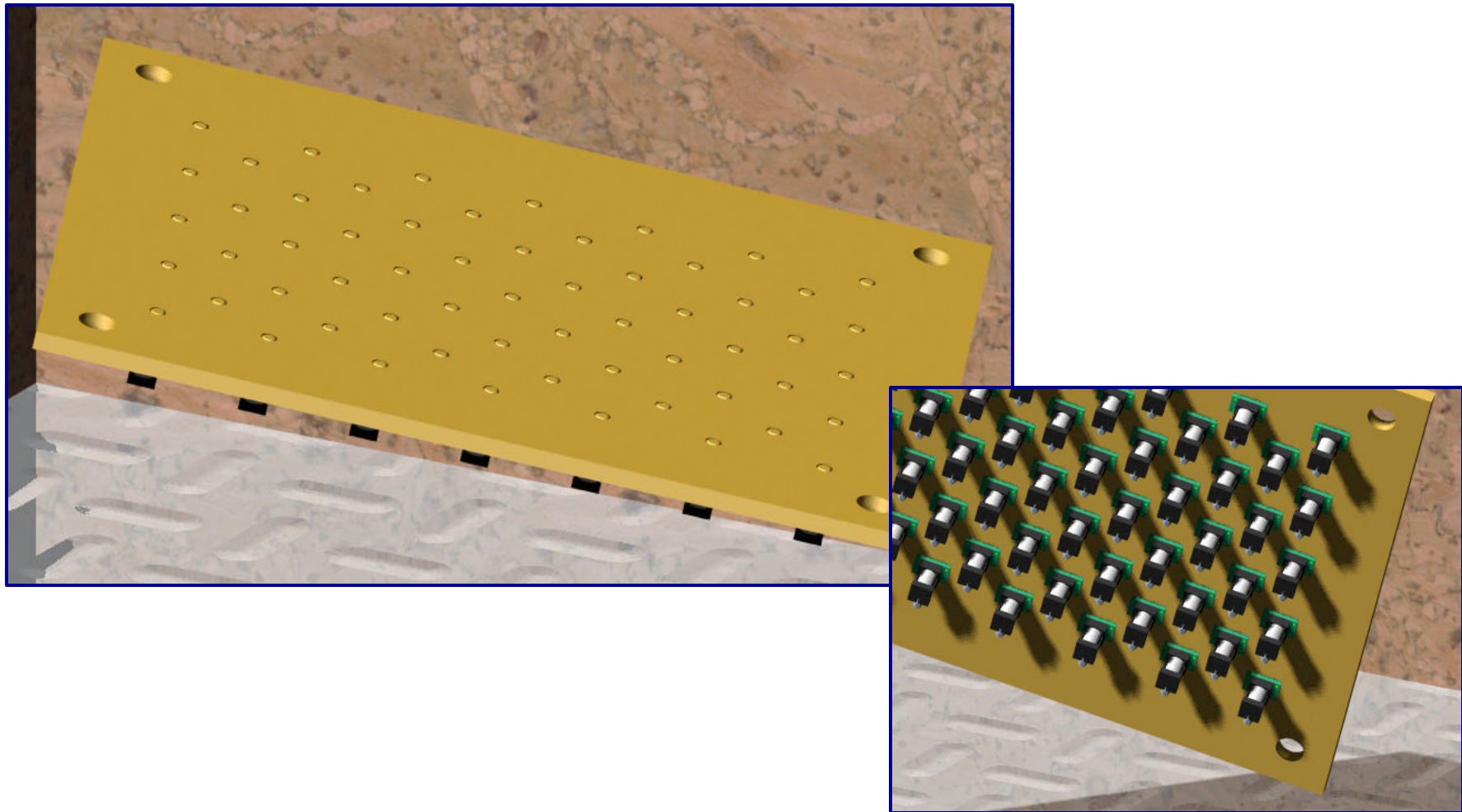

Details of the Piston System

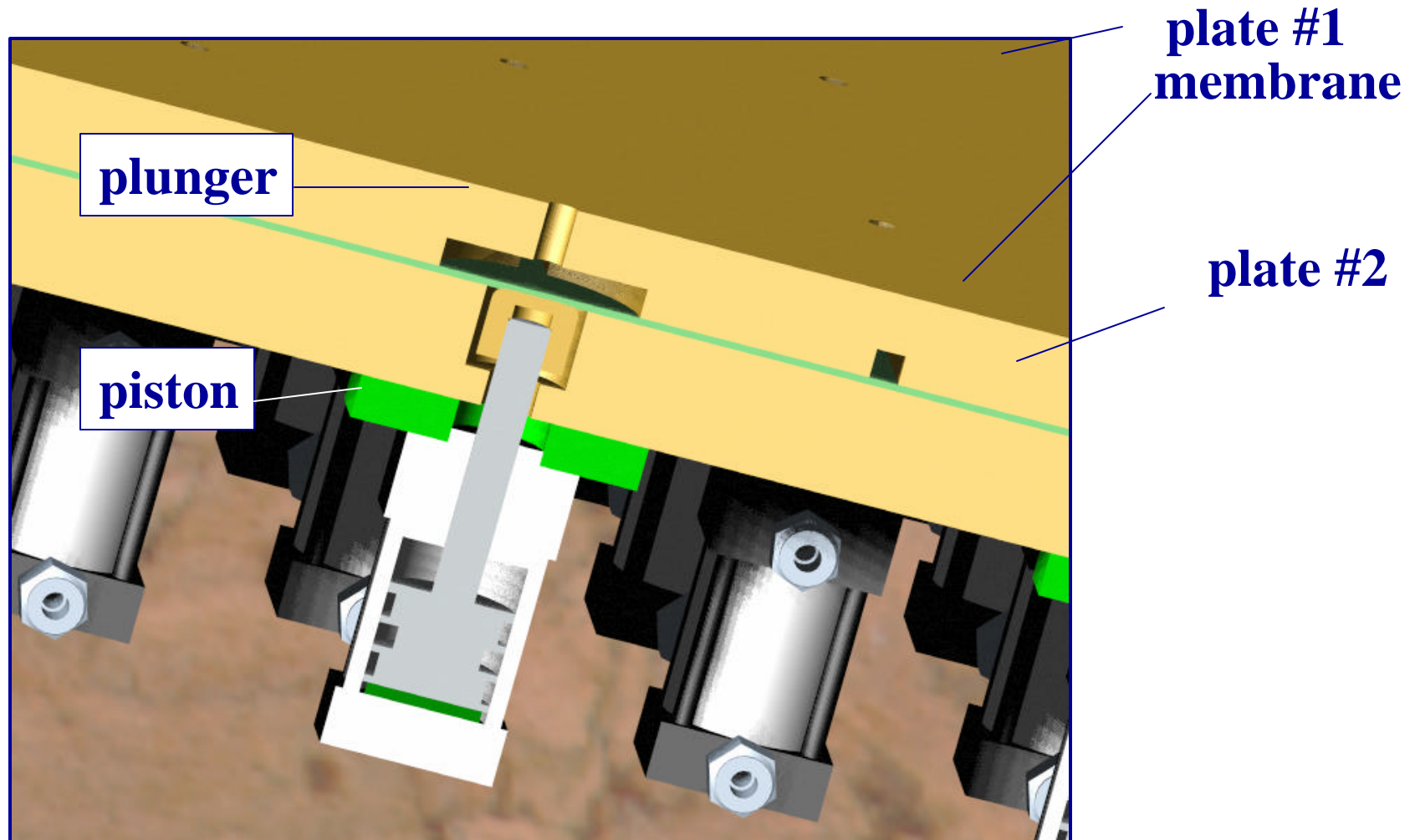

Schematic of Piston Operation: Open Position

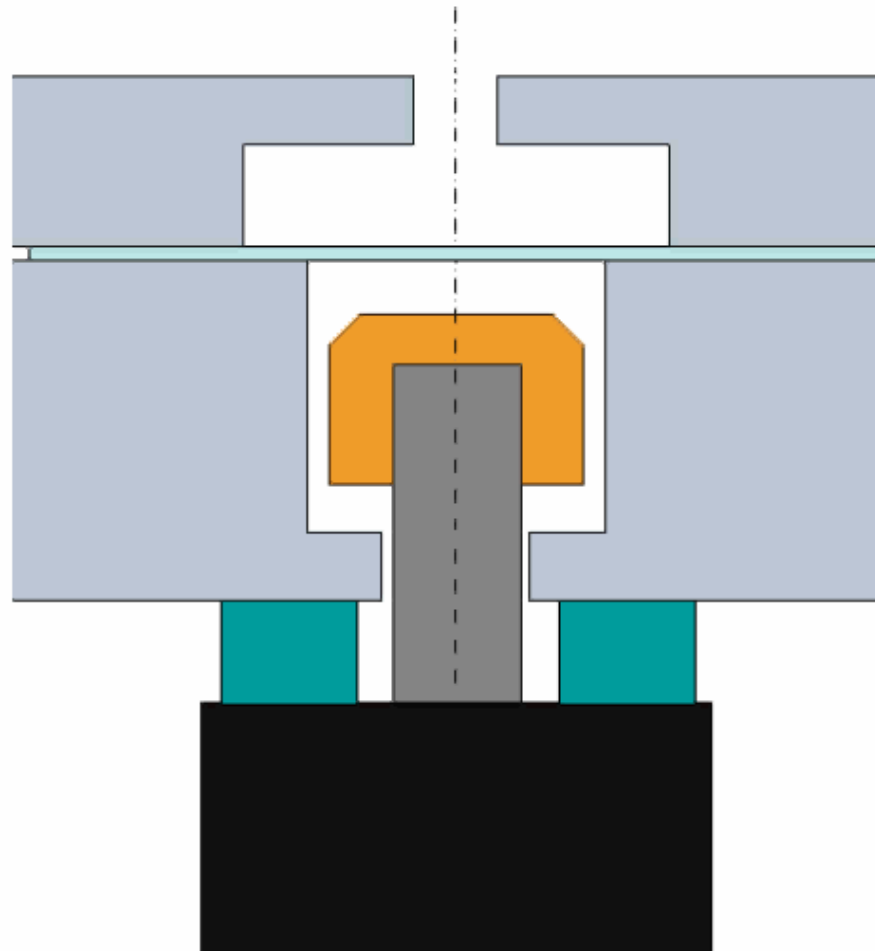

Schematic of Piston Operation: Closed Position

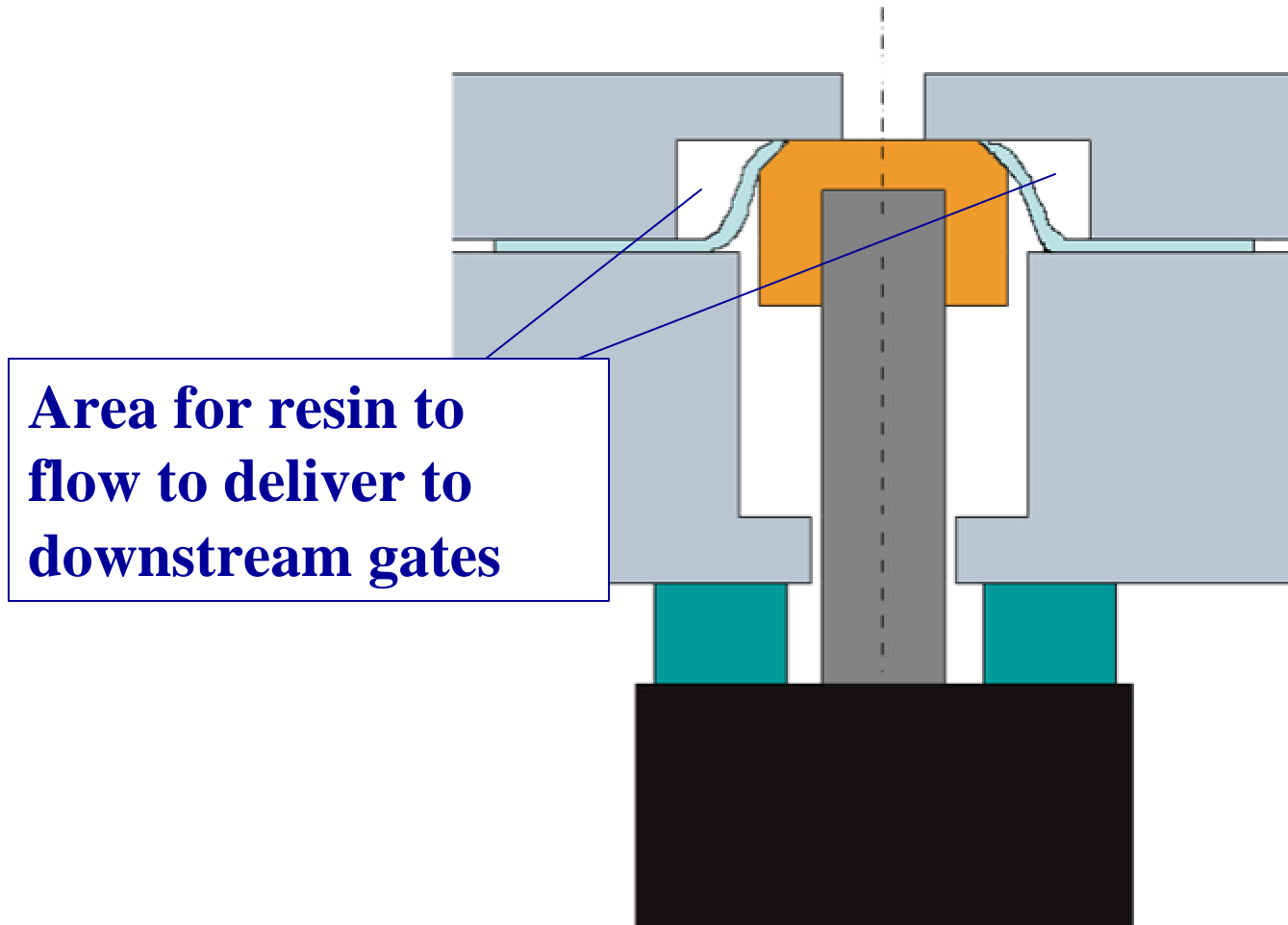

**Area for resin to
flow to deliver to
downstream gates**

Fabrication and Testing of RTM Workstation

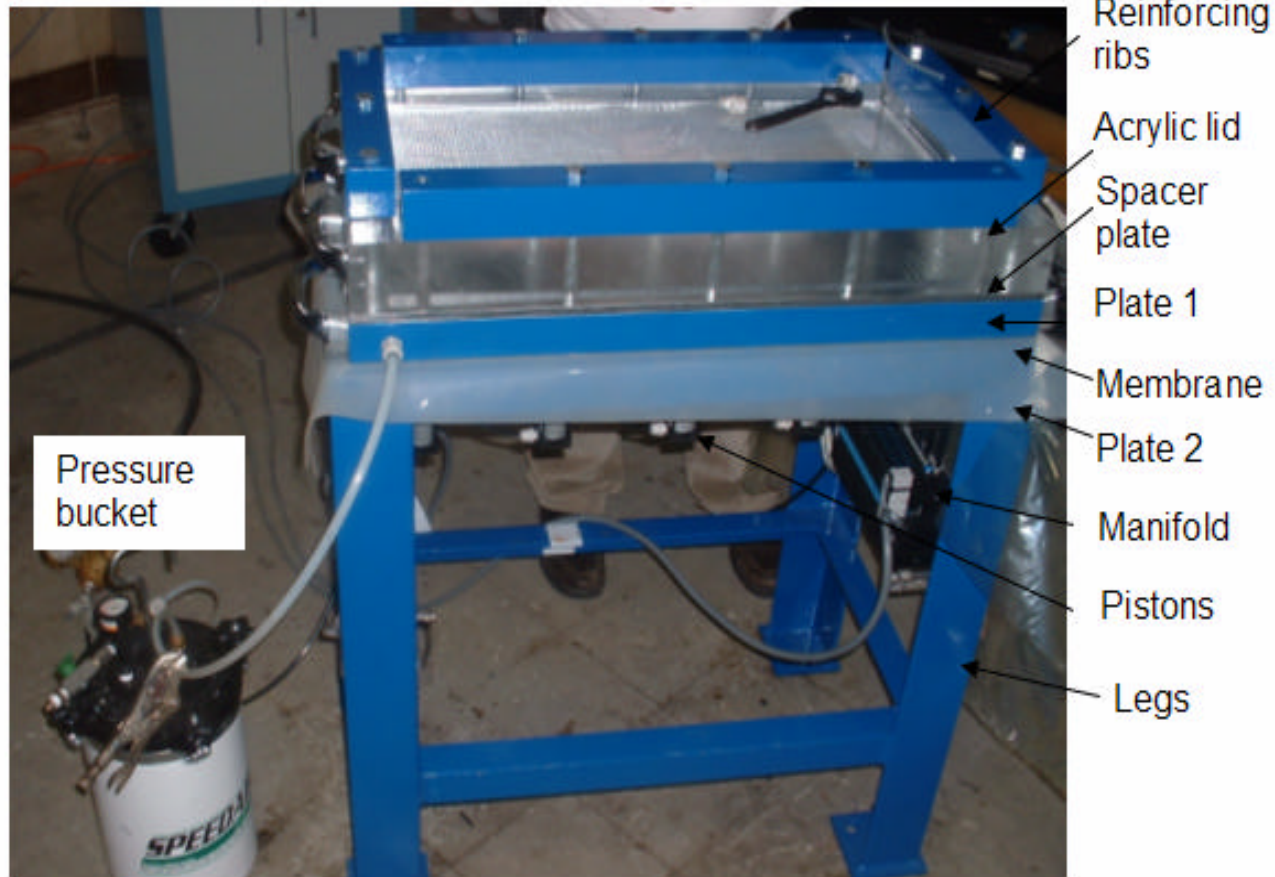

Control Center – Neatly Containing All Data Acquisition Components



First Step in the Manufacturing Cycle



The mold system is ready to start with the first part

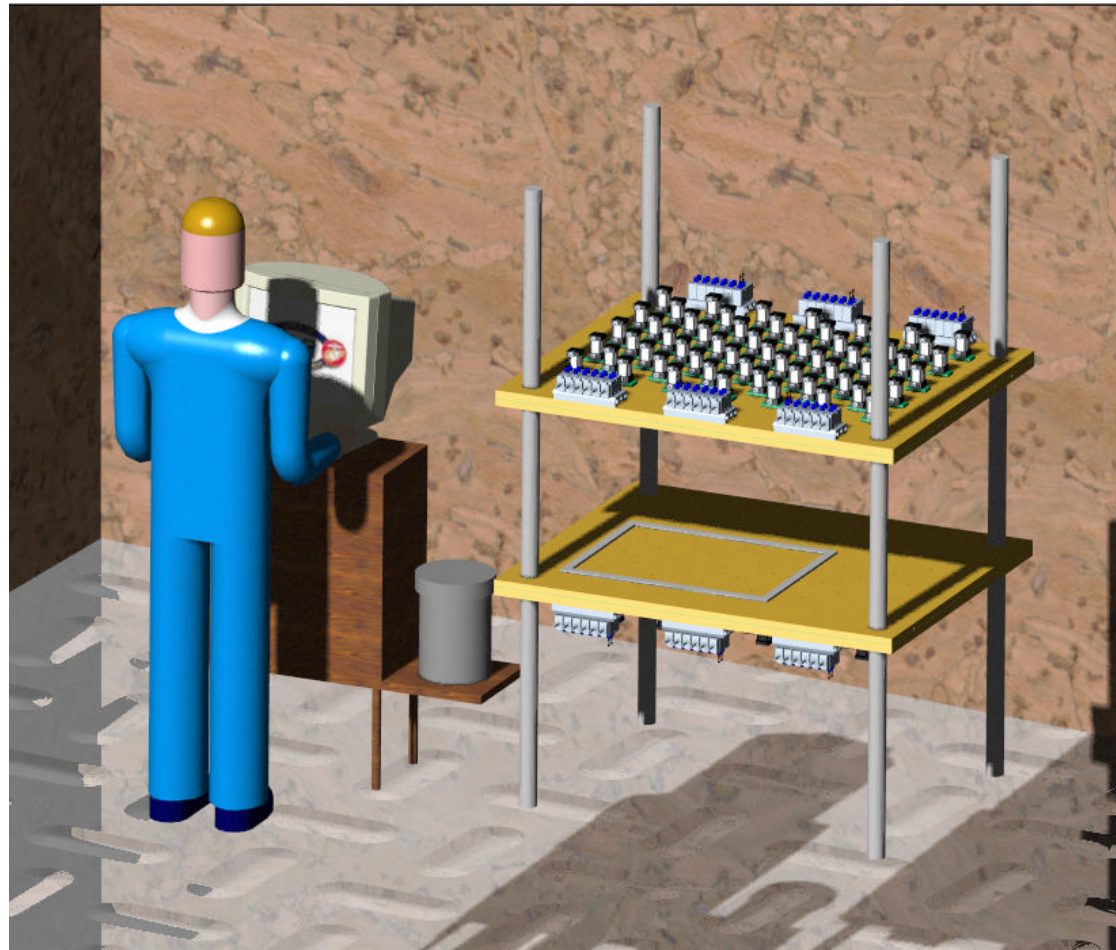

Next Step



The preform
is loaded into
the mold

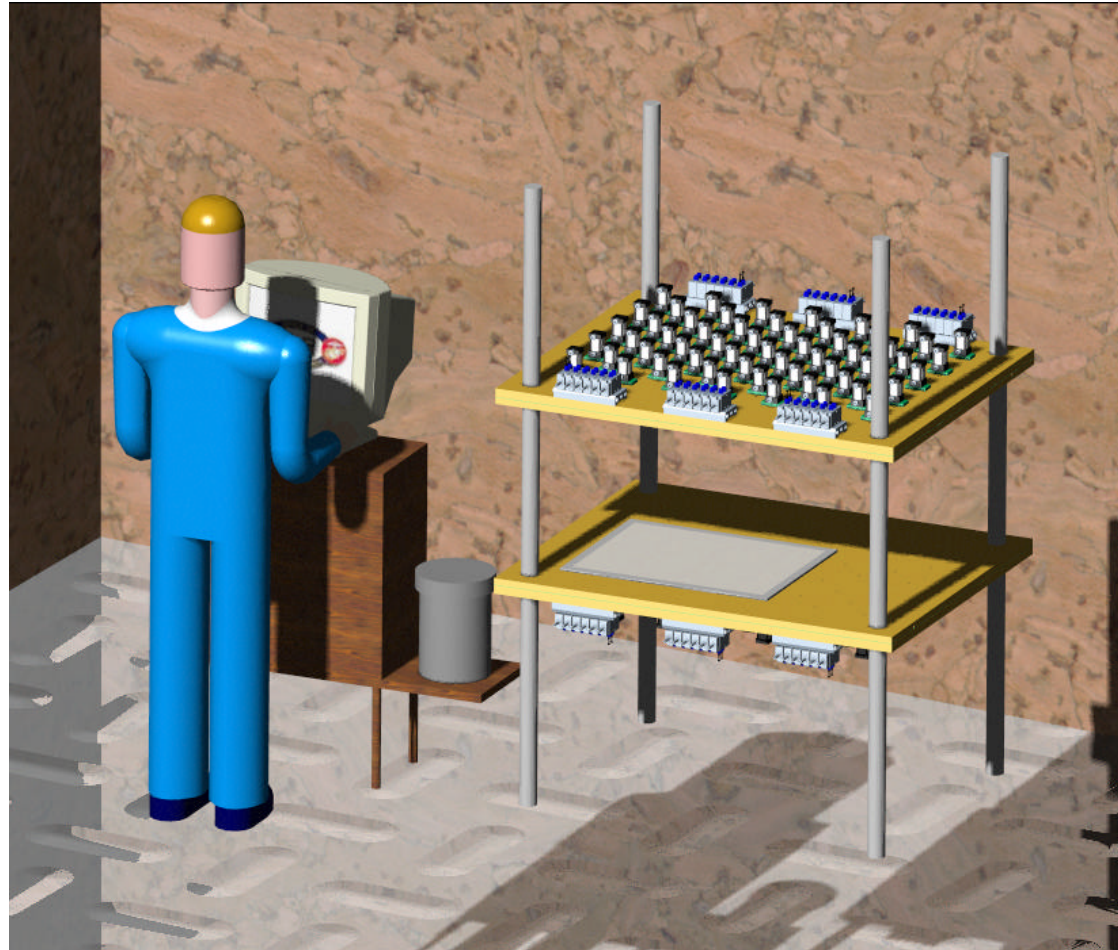

Next Step



The mold is closed and sealed, the resin is injected and allowed to cure

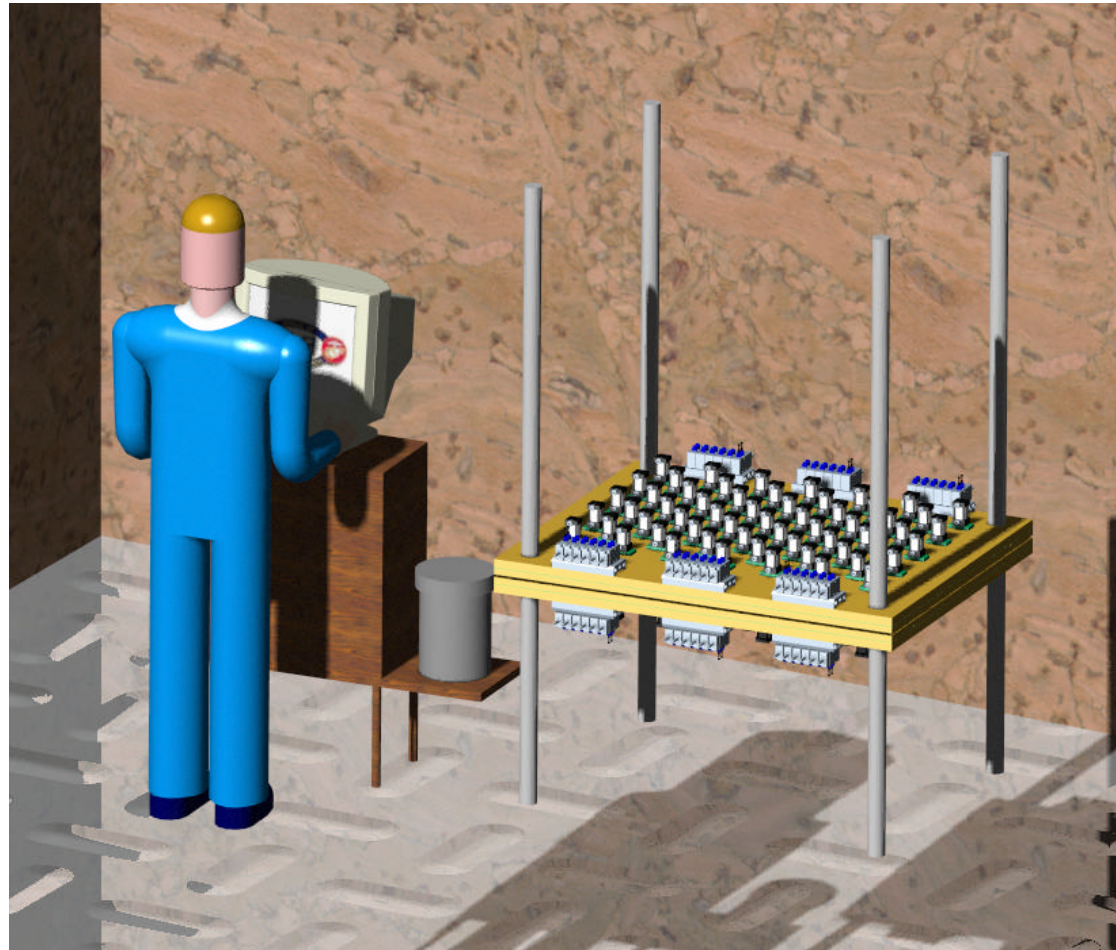

Next Step



The mold is open, revealing the filled part

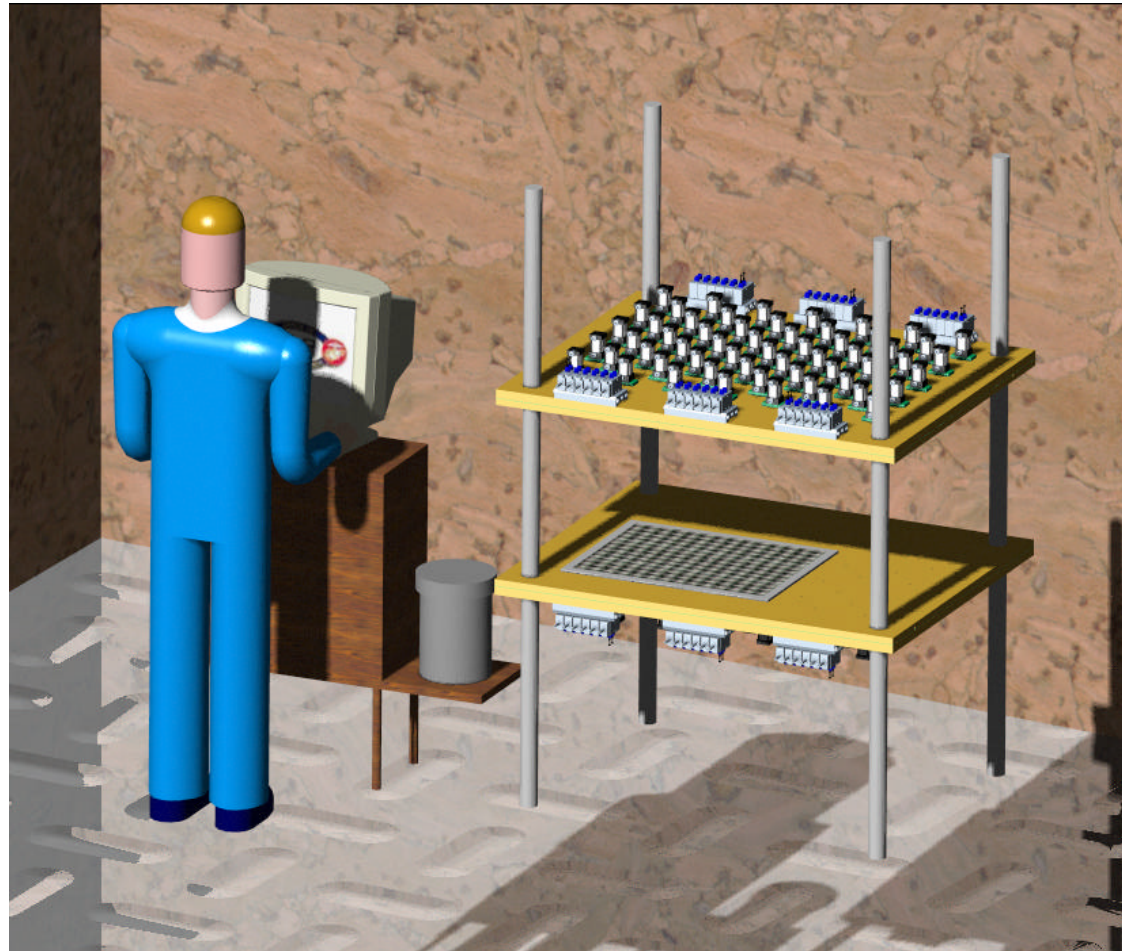

Next Step



The part is demolded ...

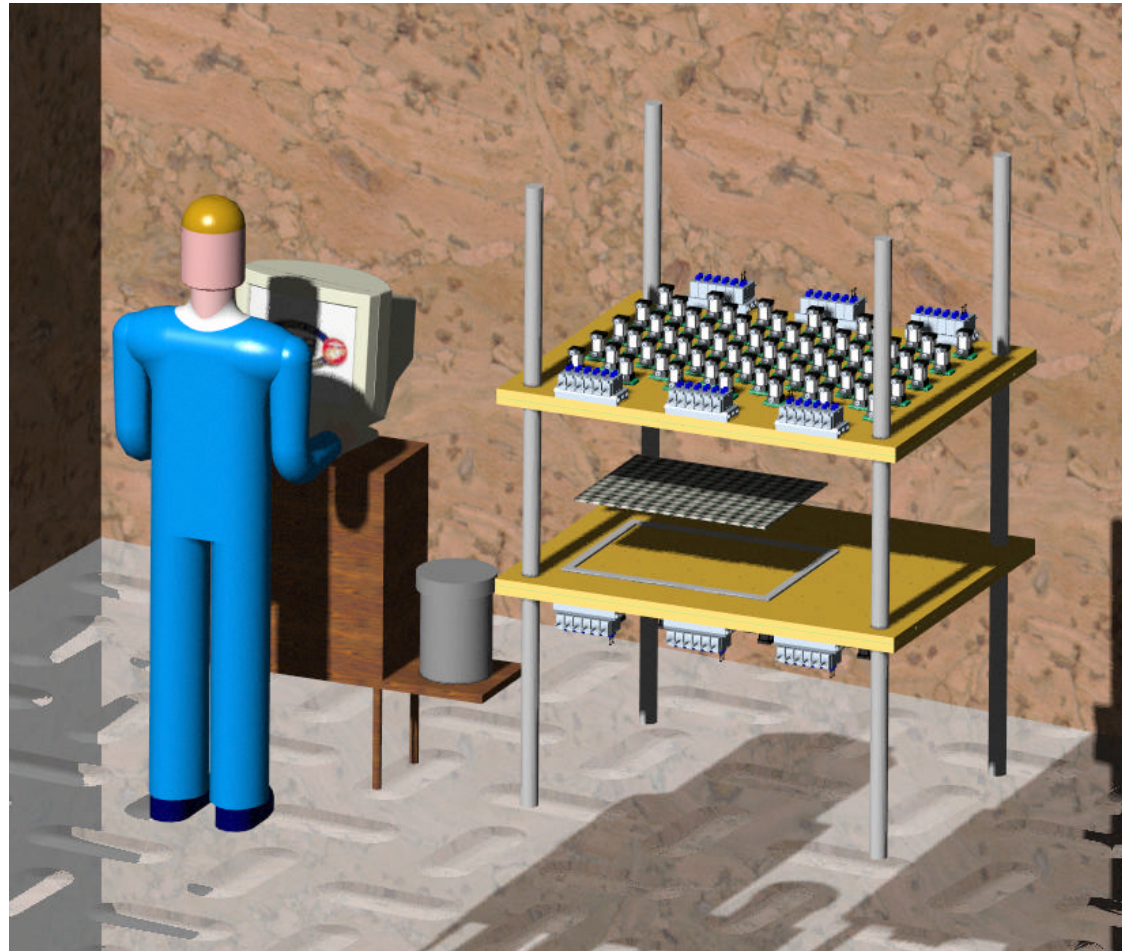

Next Step



... and
removed from
the mold

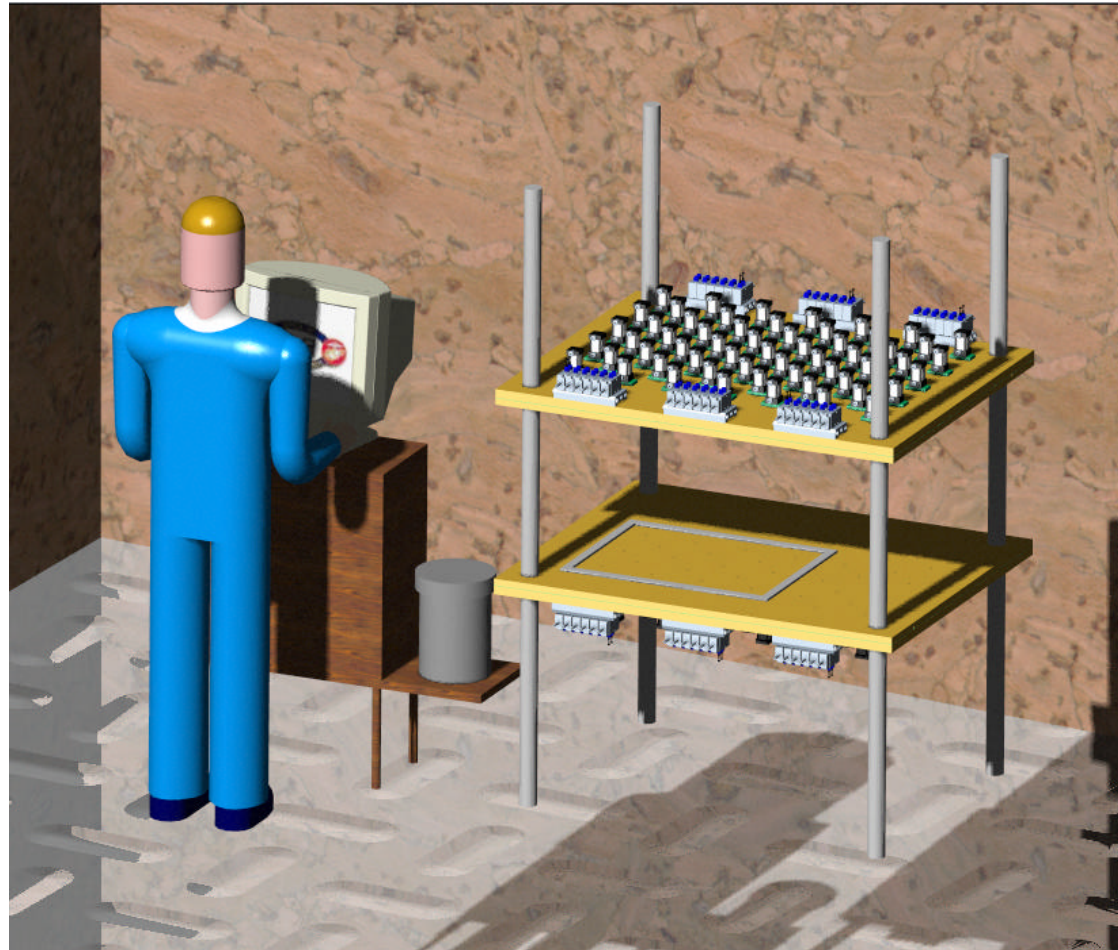

Next Step



The plate systems are separated revealing the resin chunks

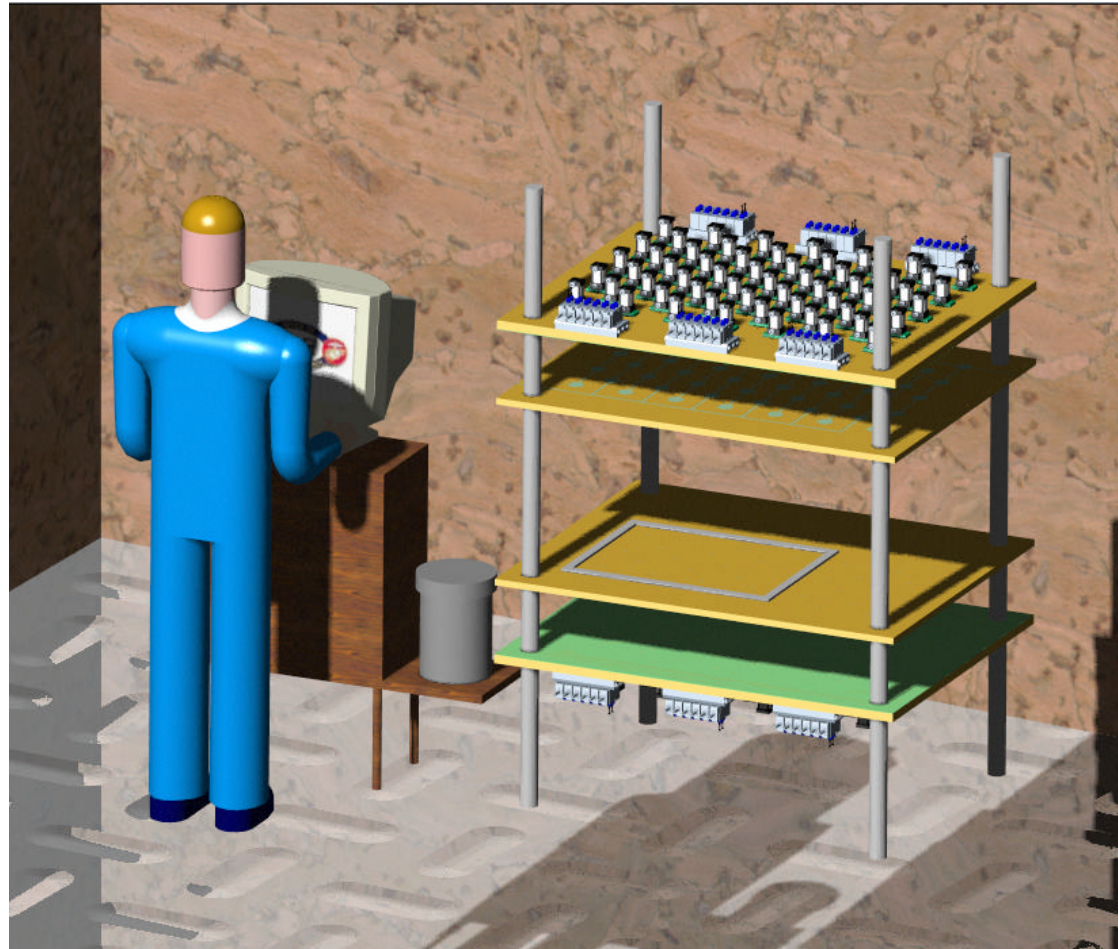

Next Step



The resin
chunks are
demolded ...

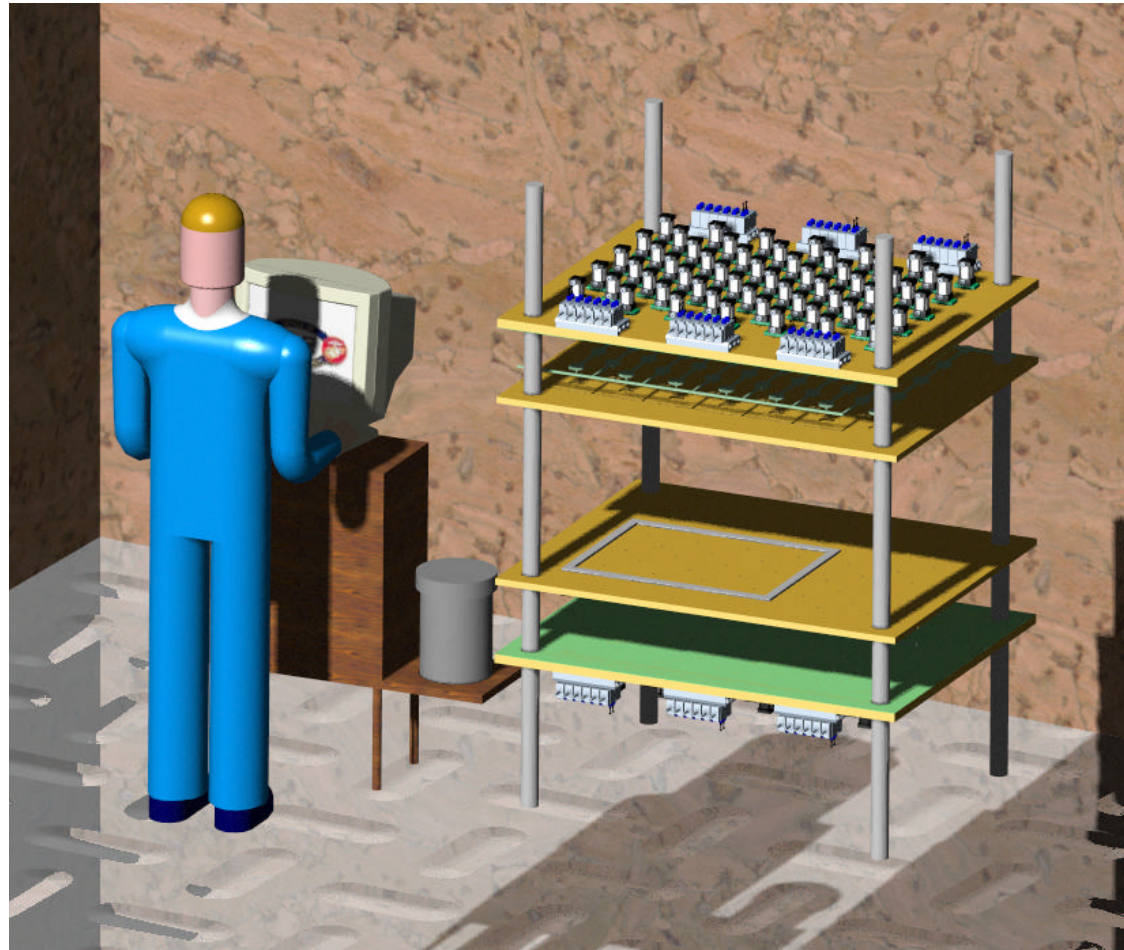

Next Step



... and
removed from
the mold

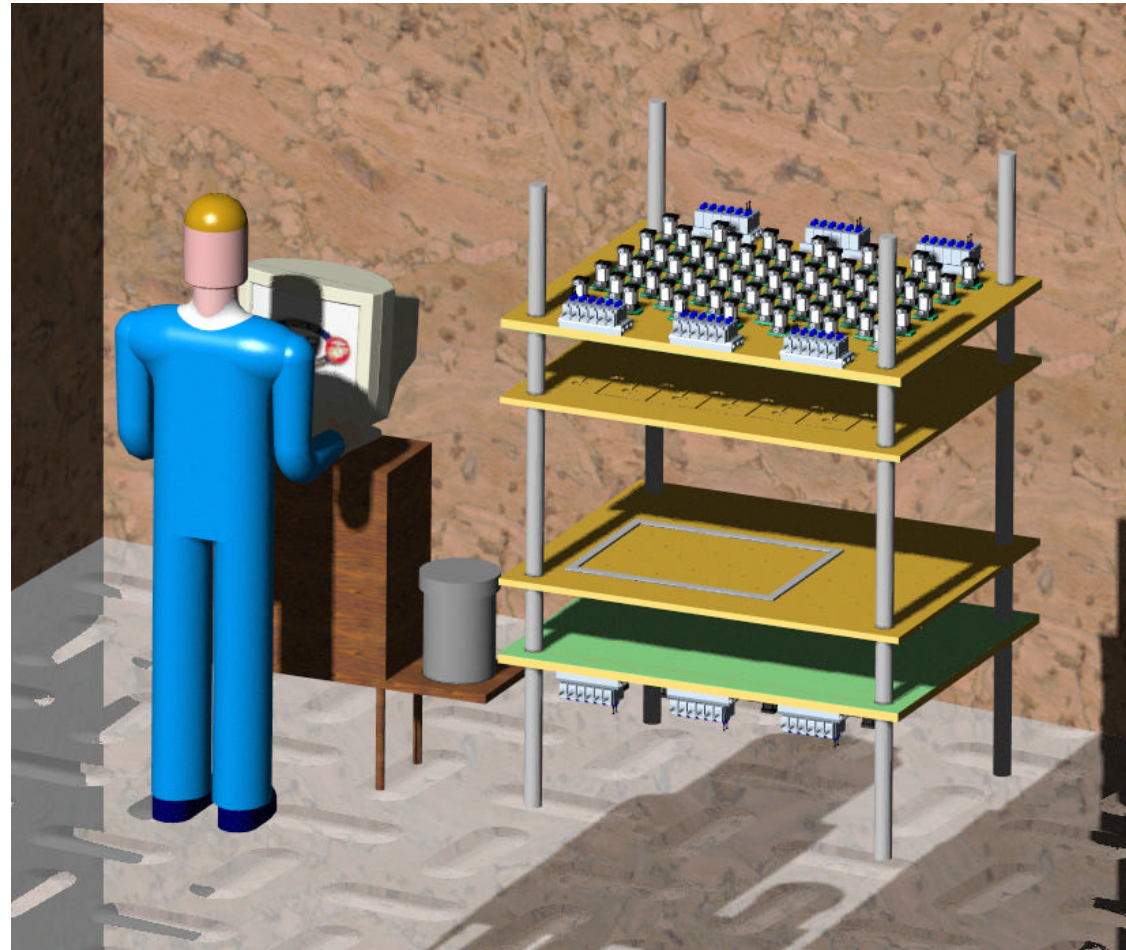

Final Step



Finally, the mold is prepared for the next part by applying release agent

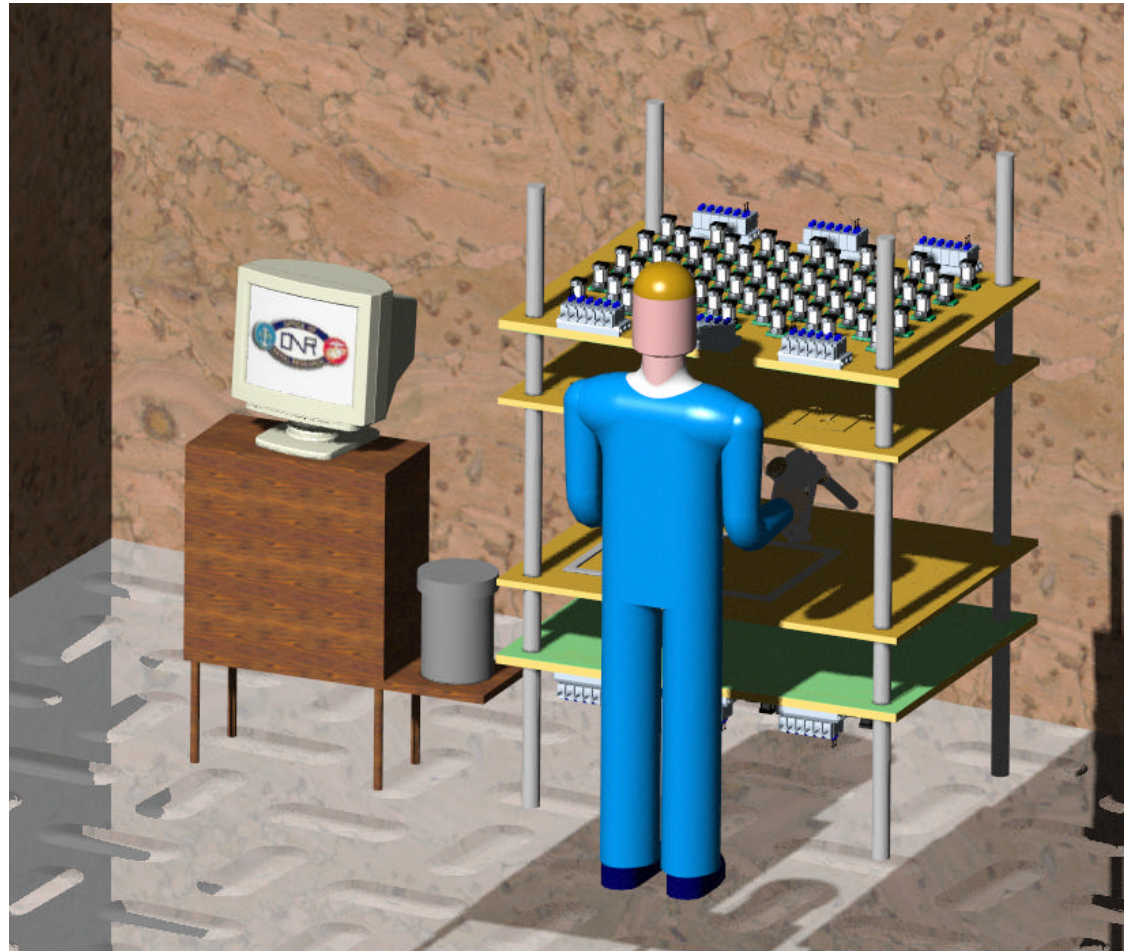

Versatility in Parts Manufactured

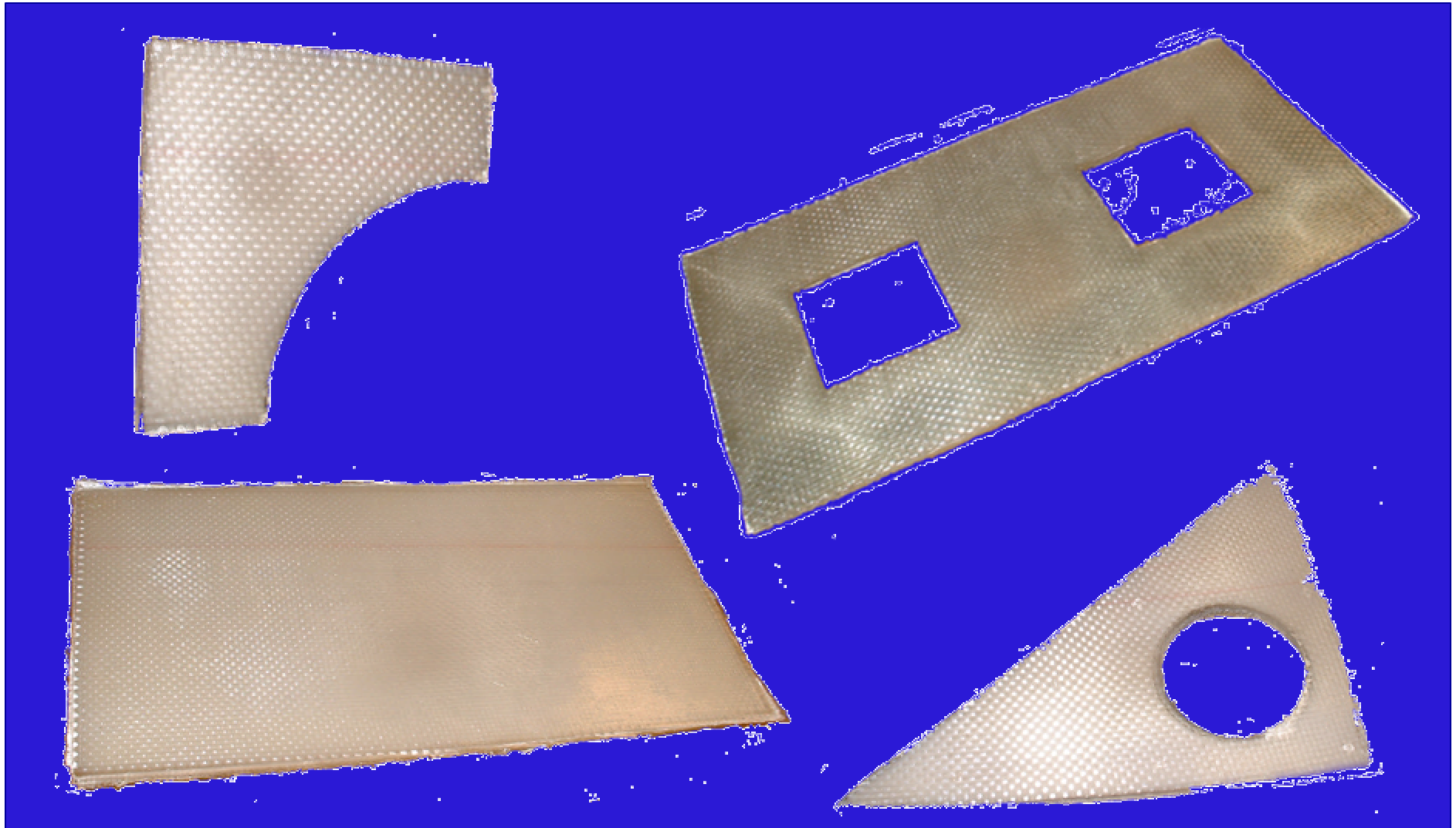

Validation Experiment

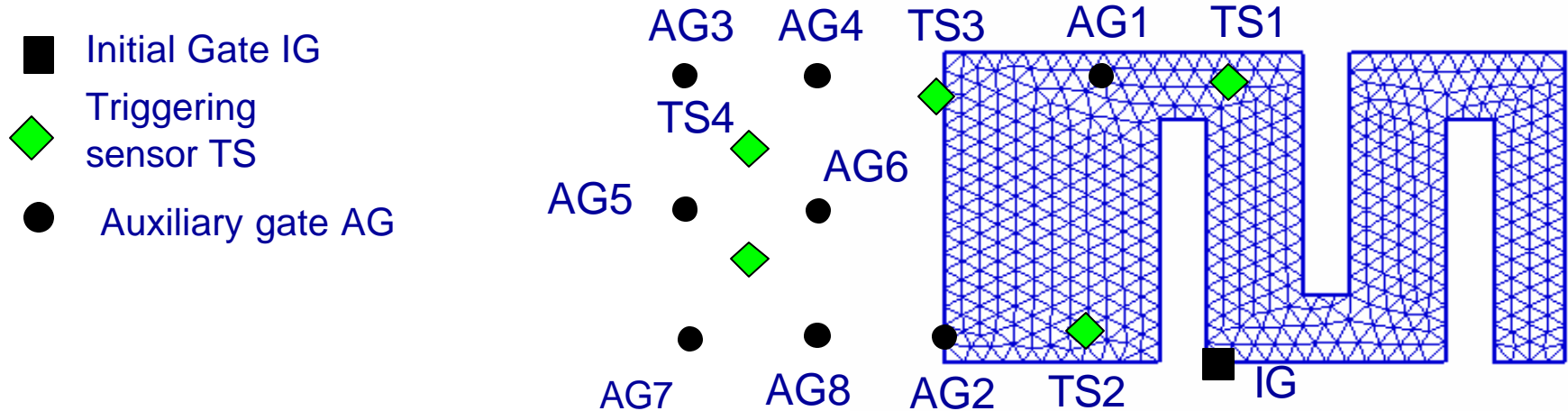

Step-2:

Flow reaches TS1, which triggers automatically opening of AG1 and closing of IG

Step-4:

Flow reaches TS3, which triggers automatically opening of AG3,4,5,6,7,8



Step-1: Initial gate opens

Step-3: Flow reaches TS2, which triggers automatically opening of AG2

Step-5: Flow reaches TS4,5, which triggers vent closing.

Sequential Injection Wizard

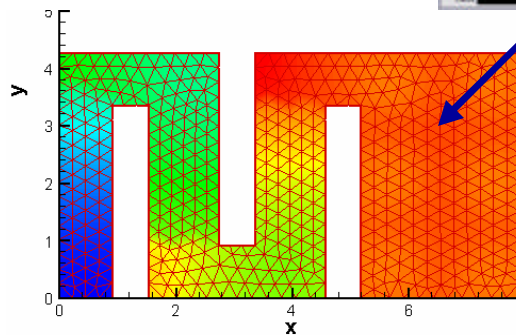
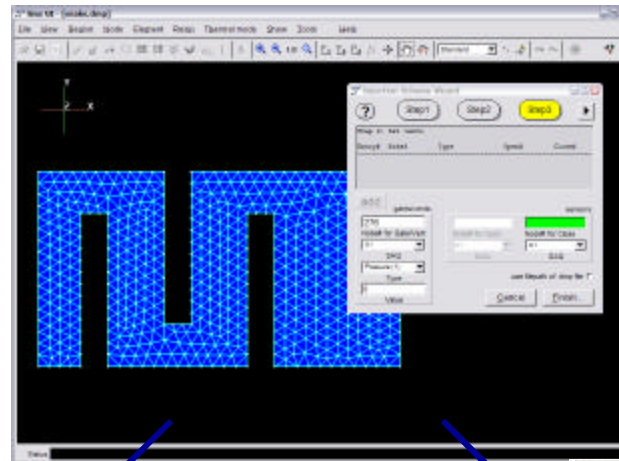

Simulation



Implementation fully automated

Sequential Injection Simulation

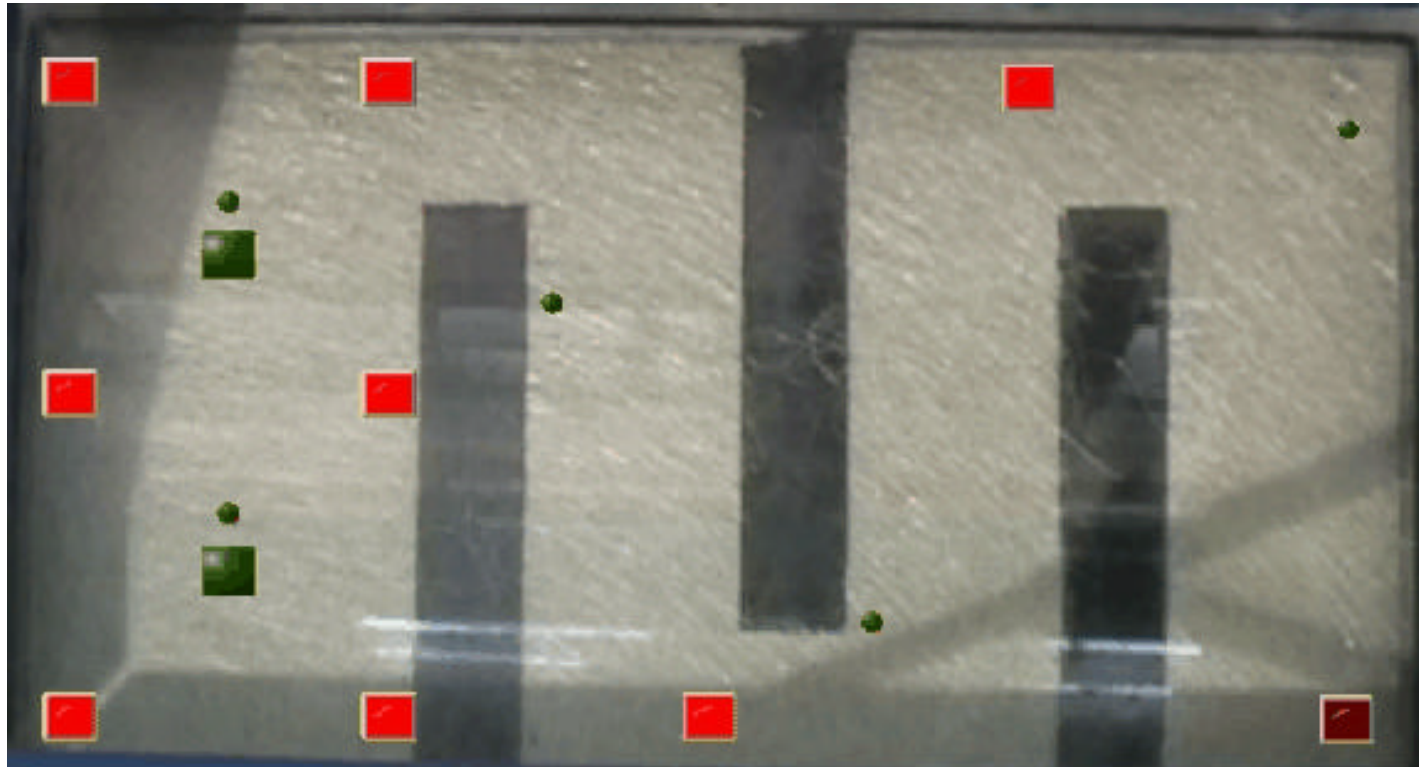

Roadmap to Automation in Liquid Molding



Design Mold and Location of Gates, Vents, Sensors

Develop Strategic Controller

Implement Active Control

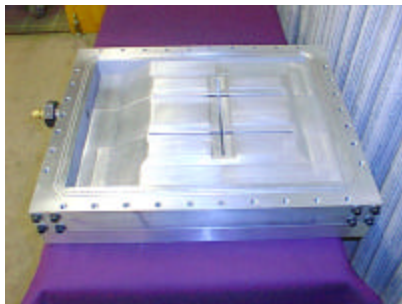

Scenario N	Gate	Flow	Psi	Temp
Scenario 3	Gate	Flow	Psi	Temp
Scenario 2	Gate	Flow	Psi	Temp
Scenario 1	Gate	Flow	Psi	Temp
Event 1	1000	3.5	80	70
Event 2	1100	3.0	90	70
Event 3	1010	2.5	70	70
...				
Event n	0001	1.5	30	75

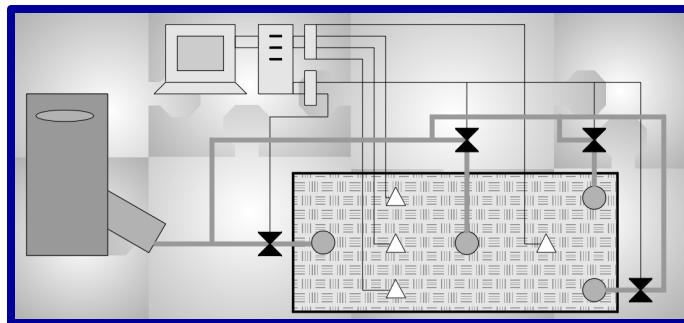
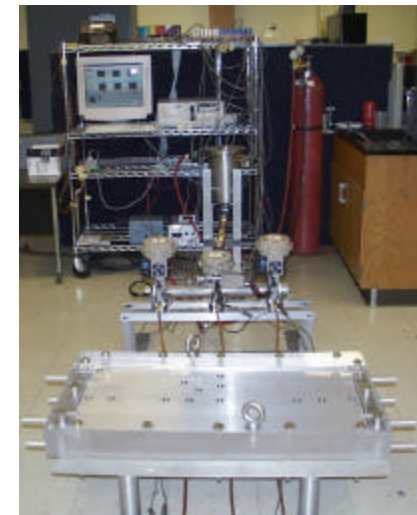

Blueprint of Automation