

**How should the fires network for the Future Force BDE level
UA be structured?**

**A Monograph
by
Major Juan K. Ulloa
United States Army**



**School of Advanced Military Studies
United States Army Command and General Staff College
Fort Leavenworth, Kansas
Academic Year 03-04**

Approved for Public Release; Distribution is Unlimited

SCHOOL OF ADVANCED MILITARY STUDIES

MONOGRAPH APPROVAL

Major Juan K. Ulloa

Title of Monograph: How should the fires network for the Future Force BDE level UA be structured?

Approved by:

Christopher Morey, Ph.D.

Monograph Director

Kevin C.M. Benson, COL, AR

Director, School of
Advanced Military Studies

Robert F. Baumann, Ph.D.

Director, Graduate
Degree Programs

Report Documentation Page

Form Approved
OMB No. 0704-0188

Public reporting burden for the collection of information is estimated to average 1 hour per response, including the time for reviewing instructions, searching existing data sources, gathering and maintaining the data needed, and completing and reviewing the collection of information. Send comments regarding this burden estimate or any other aspect of this collection of information, including suggestions for reducing this burden, to Washington Headquarters Services, Directorate for Information Operations and Reports, 1215 Jefferson Davis Highway, Suite 1204, Arlington VA 22202-4302. Respondents should be aware that notwithstanding any other provision of law, no person shall be subject to a penalty for failing to comply with a collection of information if it does not display a currently valid OMB control number.

1. REPORT DATE 26 MAY 2004		2. REPORT TYPE		3. DATES COVERED -	
4. TITLE AND SUBTITLE How should the fires network for the Future Force BDE level UA be structured?				5a. CONTRACT NUMBER	
				5b. GRANT NUMBER	
				5c. PROGRAM ELEMENT NUMBER	
6. AUTHOR(S) Juan Ulloa				5d. PROJECT NUMBER	
				5e. TASK NUMBER	
				5f. WORK UNIT NUMBER	
7. PERFORMING ORGANIZATION NAME(S) AND ADDRESS(ES) US Army School for Advanced Military Studies, 250 Gibbon Ave, Fort Leavenworth, KS, 66027				8. PERFORMING ORGANIZATION REPORT NUMBER ATZL-SWV	
9. SPONSORING/MONITORING AGENCY NAME(S) AND ADDRESS(ES)				10. SPONSOR/MONITOR'S ACRONYM(S)	
				11. SPONSOR/MONITOR'S REPORT NUMBER(S)	
12. DISTRIBUTION/AVAILABILITY STATEMENT Approved for public release; distribution unlimited					
13. SUPPLEMENTARY NOTES The original document contains color images.					
14. ABSTRACT A network is a system of sensors, information processing and decision-making centers, and firing platforms connected by communications lines. The concept of Network-Centric Warfare originated to solve operational level problems at the joint level. Networking fires at the brigade level unit of action could theoretically add to the efficiency and effectiveness of lower level tactical fires by giving units at all levels direct access to all available fires in the area of operations. This monograph constitutes an exploratory study of and preliminary analysis of the effects of networking all available fires at the brigade level UA. By carefully constructing and developing three courses of action, this monograph analyzes the effectiveness of support provided under three different fires intensity levels - low, medium, and high - with respect to five measures of effectiveness: responsiveness, effectiveness, efficiency, complexity, and the human dimension. Using operations research and systems analysis techniques to combine the different measures of effectiveness and the effects of operating under situations requiring different levels of fires intensity, the results suggest that the most fertile area for further research and development of fires networks is in the region of composite network structures that can exploit the advantages of both the flat and hierarchical structures while still making improvements in other areas that the other two are weak.					
15. SUBJECT TERMS					
16. SECURITY CLASSIFICATION OF:			17. LIMITATION OF ABSTRACT 1	18. NUMBER OF PAGES 99	19a. NAME OF RESPONSIBLE PERSON
a. REPORT unclassified	b. ABSTRACT unclassified	c. THIS PAGE unclassified			

ABSTRACT

A STUDY INTO HOW THE FIRES NETWORK FOR THE FUTURE FORCE BDE LEVEL UA SHOULD BE STRUCTURED: by Major Juan K. Ulloa, United States Army, 92 pages.

A network is a system of sensors, information processing and decision-making centers, and firing platforms connected by communications lines. The concept of Network-Centric Warfare originated to solve operational level problems at the joint level. Networking fires at the brigade level unit of action could theoretically add to the efficiency and effectiveness of lower level tactical fires by giving units at all levels direct access to all available fires in the area of operations.

This monograph constitutes an exploratory study of and preliminary analysis of the effects of networking all available fires at the brigade level UA. By carefully constructing and developing three courses of action, this monograph analyzes the effectiveness of support provided under three different fires intensity levels – low, medium, and high – with respect to five measures of effectiveness: responsiveness, effectiveness, efficiency, complexity, and the human dimension. Using operations research and systems analysis techniques to combine the different measures of effectiveness and the effects of operating under situations requiring different levels of fires intensity, the results suggest that the most fertile area for further research and development of fires networks is in the region of composite network structures that can exploit the advantages of both the flat and hierarchical structures while still making improvements in other areas that the other two are weak.

TABLE OF CONTENTS

I. INTRODUCTION.....	1
A. BACKGROUND.....	1
B. MONOGRAPH OVERVIEW.....	5
II. SCOPE.....	6
A. INCLUDED IN MONOGRAPH.....	6
B. OUTSIDE SCOPE OF MONOGRAPH.....	7
III. SCENARIOS.....	9
A. Criteria.....	9
1. Responsiveness.....	9
2. Efficiency and Effectiveness.....	10
3. Complexity.....	11
4. Human Dimension.....	11
B. DESIGN OF EXPERIMENT.....	11
1. Design.....	12
2. Experiment.....	14
IV. ANALYSIS.....	17
A. METHODOLOGY.....	17
B. PRESENTATION AND ANALYSIS OF PROCESSED DATA.....	19
1. Experimental Data.....	19
a. Responsiveness.....	20
b. Efficiency and effectiveness.....	22
2. Other Data.....	22
a. Complexity.....	22
b. Human Dimension.....	27
3. Multi-Attribute Utility Model.....	32
C. CONCLUSIONS.....	36

V. CONCLUSIONS AND RECOMMENDATIONS.....	37
A. Conclusions	37
B. Issues.....	40
1. Parameters for the Experiment.....	40
2. MAUM.....	41
C. Recommendations.....	41
1. Quick-fire Channels.....	42
2. Limits to Responsiveness Gains from Flattening the Network.....	42
3. Efficiency and Effectiveness	42
4. Optimizing Locally versus Globally.....	43
GLOSSARY	44
APPENDIX 1 - Task Organization Of Brigade-Level Unit of Action	45
APPENDIX 2 – Experiment Static and Dynamic Variables	45
Annex A – Node table and experimental design	45
Annex B – Network Arc-Node List with times to travel along arcs	47
Annex C – Flat Network Structure Diagram with arc and node values and node names	49
Annex D – Hierarchical Network Structure with arc and node values and node names	50
Annex E – Composite Network Structure with arc and node values and node names.....	51
APPENDIX 3 – Programming and Output Data.....	51
Annex A – Program and Output Data for Flat Structure w/ Low Intensity	51
Annex B – Program and Output Data for Flat Structure w/ Medium Intensity.....	55
Annex C – Program and Output Data for Flat Structure w/ High Intensity.....	59
Annex D – Program and Output Data for Hierarchical Structure w/ Low Intensity	63
Annex E – Program and Output Data for Hierarchical Structure w/ Medium Intensity	67
Annex F – Program and Output Data for Hierarchical Structure w/ High Intensity	72
Annex G – Program and Output Data for Composite Structure w/ Low Intensity	77
Annex H – Program and Output Data for Composite Structure w/ Mediu Intensity	81
Annex I – Program and Output Data for Composite Structure w/ High Intensity	85
BIBLIOGRAPHY	91

LIST OF FIGURES

Figure 1 - Logical Model for Network-Centric Warfare.....	3
Figure 2 - Network Effectiveness Diagram	9
Figure 3 - Completely Flat FS Structure	12
Figure 4 - Hierarchical FS Structure	13
Figure 5 - Compromise between Figures 3 and 4.....	13
Figure 6 - Example of the experiments for low-level intensity.....	15
Figure 7 - Example of the experiments for mid-level intensity	15
Figure 8 - DS Mission Flow	20
Figure 9 - Example of three systems with four nodes that have different complexities	24
Figure 10 - Example of three systems with six arcs that have different complexities.....	24
Figure 11 - Graph of Utility over Intensity.....	37

LIST OF TABLES

Table 1 - Experimental Design (# indicates the result of the experiment)	14
Table 2 - Table of raw MOE data for each COA under each intensity level.....	18
Table 3 - Normalized Changes to Timeliness.....	21
Table 4 - Utility based on Network Complexity	27
Table 5 - Raw MOE Data (low intensity)	33
Table 6 - Utility of each structure under Low Intensity	33
Table 7 - Raw MOE Data (medium intensity)	34
Table 8 - Utility of each structure under Medium Intensity	34
Table 9 - Raw MOE Data (high intensity)	35
Table 10 - Utility of each structure under High Intensity	35
Table 11 - Overall Utility of each COA/Structure	36

ACKNOWLEDGEMENTS

The author would like to thank many individuals whose guidance and help were essential to the completion of this monograph. I wish to thank Dr. Morey for taking time out of his busy schedule and magnanimously agreeing to oversee this monograph. His advice, mentorship, and editing made this a much better product than it otherwise would have been.

The ideas and views expressed in this paper are those of the author and do not necessarily reflect the official policy or position of the Command General Staff College, the School of Advanced Military Studies, or Department of the Army.

I. INTRODUCTION

A. BACKGROUND

In January 1998 Vice Admiral Arthur Cebrowski argued that the US Military should change the way it wages war from platform-centric to network-centric. His argument was based on examples from the business sector, which, through ruthless competition, optimized its practices to maximize profit by increasing efficiency and productivity. By shifting their emphasis from platforms to networks, forward thinking businesses were better able to take advantage of the value of information than their competitors. Simply put, these highly dynamic organizations essentially locked their competition out of the market by more quickly creating and marketing products that were more relevant to consumers worldwide.¹

Cebrowski's vision is to create these same conditions on the battlefield against our enemies. According to Cebrowski, Network-centric warfare (NCW) can succeed in locking out the enemy by achieving speed of command and enabling the force to "organize from the bottom up – or to self-synchronize – to meet the commander's intent."² The network; a system of sensors, information processing and decision-making centers, and firing platforms connected by communications lines; enables speed of command by (1) attaining information superiority, dramatically superior awareness and understanding of the battlespace, and (2) acting with speed and precision to mass effects without having to mass forces. Having more information and reacting to it more quickly than the enemy, enabled by bottom-up organization, compresses our "Observe-Orient-Decide-Act (OODA) Loop" so much, that for all intents and purposes, our

¹ Cebrowski, Arthur K., and John J. Garstka. "Network-Centric Warfare: Its Origin and Future." *US Naval Institute Proceedings* (January 1998), 1-5. Available online at <https://www.usni.org/Proceedings/Articles98/PROcebrowski.htm>. Site last visited 05 November, 2003.

OODA Loop essentially disappears in the enemy's eyes. Because of what is essentially the compression of our OODA Loop, the enemy is denied operational pauses throughout the spectrum of operations and emerging enemy courses of action are "locked-out"³

At this point it is useful to define some terms that will help us visualize and work with the network. As stated earlier, the network is a system of sensors, information processing and decision-making centers, and firing platforms connected by communications lines. The sensors, centers, and platforms are physical entities that perform some sort of function. They are nodes within the system. By moving information to and from the different nodes, the communications links tie the nodes together. These communications links are arcs within the network.

The emerging logical model for NCW is based on the information, sensor, and engagement grids shown in figure 1 on the following page. The information grid enables the architecture of the sensor and engagement grids by quickly passing information back and forth from sensors to shooters. The sensor grid creates data, the information grid uses data to create awareness and pass information throughout the battlespace, while the engagement grid exploits battlespace awareness and translates it into combat power.⁴

² Ibid., 6.

³ Ibid., 8.

⁴ Ibid., 9–10.

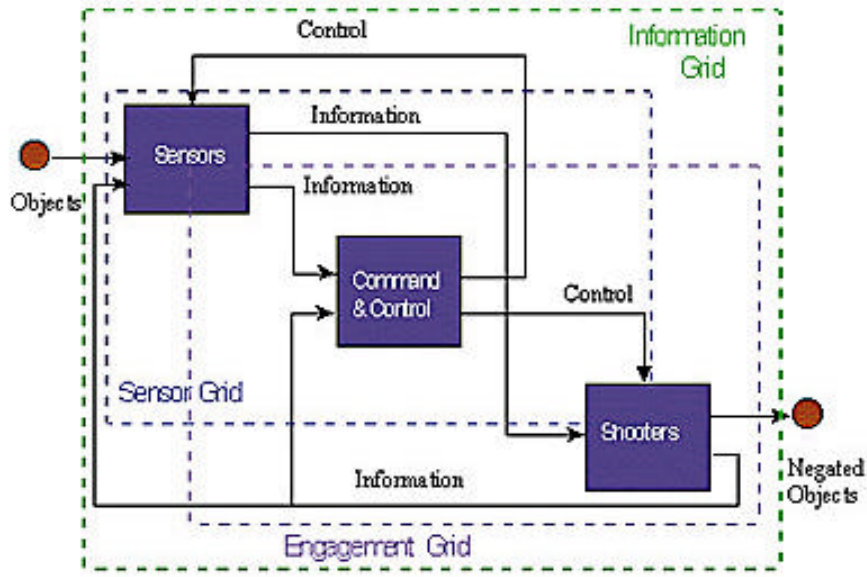

Figure 1 - Logical Model for Network-Centric Warfare⁵

The concept of NCW originated to solve operational level problems at the joint level. The architecture to enable NCW is being put into place today to enable the joint force to fight more effectively *and* more efficiently. The concept of NCW makes sense and may work at the operational and upper tactical levels of targeting, but since most tactical units at brigade and lower levels tend to have low priorities of fires for strategic and operational level assets, NCW may have minimal impact for units at the lowest tactical levels when attacking targets of opportunity.

Although originally conceived to solve operational level problems, it is logical to assert that NCW must be enabled at successively lower levels until the entire force is integrated to fully realize the potential of the concept. The essence of networking fires for the Army is a step in that direction. Networking fires at the brigade level unit of action (UA) would theoretically add to the

⁵ Ibid., 10.

efficiency and effectiveness of lower level tactical fires by giving units at all levels direct access to all available fires in the area of operations (AO).

The Army has fully embraced the concept of NCW for the future force. Annex H of the final draft to TRADOC Pamhlet 525-3-90 states that

In order to make the right decisions, leaders must receive a constant flow of timely and accurate information to facilitate and support situational awareness development. Information technology systems, properly networked, simultaneously share information with virtually any warfighter, regardless of location by a high performance information grid and access to multiple information sources. This is network-centric warfare.⁶

In order for NCW to work properly Army fires and effects must be fully integrated with joint force capabilities to achieve full spectrum dominance against any adversary in the most austere of environments.⁷

At the heart of the transformation of Army fires is the need to develop the tactical situation out of contact, beyond the range of enemy weapon systems, destroying them with precision fires, thereby reducing the need to rely on tactical assault to achieve tactical decisions. This can be achieved only by applying fire in a much more holistic manner than in the past.⁸ That holistic manner is “dynamic target attack with unprecedented responsiveness to all echelons of the force... enabled by the FF [future force] BCS [Battle Command system] network.”⁹

⁶ Headquarters, United States Army Training and Doctrine Command. *TRADOC Pamphlet 525-3-90, The United States Army Objective Force Operational and Organizational Plan, Maneuver Unit of Action. (Coordinating Draft), Change 2* (Fort Monroe, VA, 30 June 2003), H-1.

⁷ Headquarters, United States Army Training and Doctrine Command, *TRADOC Pamphlet 525-3-9, Objective Force Fires and Effects Concept of Operation (Coordinating Draft)* (Fort Monroe, VA, 02 July, 2003), 5.

⁸ *Ibid.*, 7.

⁹ *Ibid.*, 16.

TRADOC Pamphlet 525-3-9, Future Force Fires and Effects Concept of Operations and TRADOC Pamphlet 525-3-90, The United States Army Objective Force Operational and Organizational Plan Maneuver Unit of Action, talk extensively about NCW and the power of networking fires. Both pamphlets outline the effects they want from the network, but conspicuously, these documents do NOT define what the network looks like. Although the desired capabilities are all encompassing, the design of the network, and the practical limitations of fully flattening the fire support structure are not addressed.

In theory it would be desirable to fully network all fires by completely *flattening* the fire support structure (i.e. creating direct communications links between all sensor and firing platforms to a central information processing and decision making entity). To determine the optimal level of networking, however, the system must be analyzed holistically to find out what the higher order effects and their consequences are. Any analyses of the networking fires concept must account for the human dimension, added complexity, survivability, and timeliness as well as effectiveness.

B. MONOGRAPH OVERVIEW

This monograph constitutes an exploratory study of and preliminary analysis of the effects networking all available fires at the brigade level UA. Each possible way to structure the network, of which there are literally hundreds of thousands, constitutes a possible course of action (COA). By designing and analyzing two structures that parameterize the field of feasible, acceptable, and suitable (FAS) COA's (i.e. bound the problem) and an additional COA to establish the middle ground, this monograph will establish three points in the spectrum highlighting the strengths and weaknesses of each point. These three points give a good representation of the entire spectrum of COA's that meet the FAS criteria, and thereby help to define the effects of different degrees of networking based on the criteria and the inputs.

Since the network will react differently based on the intensity of the number of fire missions requested, in much the same manner that the COA's were parameterized, the intensity of fires (number of fire missions over a specific time period) will be parameterized as well.

In order to provide a well-rounded analysis, this monograph will address both qualitative and quantitative criteria to measure the effectiveness of each COA. All criteria will be combined into one number that summarizes the overall utility of each COA based on the evaluation criteria and subjective inputs from the decision-maker.

II. SCOPE

The objective of this monograph is to explore some of the implications of the networking fires concept at the brigade UA level and below and to determine how centralized the decision making for apportionment of fires should be to optimize effectiveness based on the criteria in chapter III. This objective will limit the scope of the monograph as outlined below.

A. INCLUDED IN MONOGRAPH

This monograph will include the effects of networking all indirect fires as well as aviation fires that reside within the UA in accordance with emerging doctrine, to include TRADOC Pamphlet 525-3-9: Future Force Fires and Effects Concept of Operation (9 September 2003 Final Coordinating Draft) and TRADOC Pamphlet 525-3-90: The United States Army Objective Force Operational and Organizational Plan Maneuver Unit of Action. (30 June 2003 Final Coordinating Draft). The indirect fire assets that will be included are the combined arms battalion non-line of sight (NLOS) mortar battery platoons and the UA NLOS Battalion platoons. The aviation assets are the two companies in the UA aviation squadron.

Since joint, coalition, and other external fires are likely to be available to the maneuver UA, this monograph will also analyze and address how and where to best tie those fires into the UA fires network. External fires that will be included in the scenarios created to test different

network structures will include US naval surface fire support (NSFS), US and/or coalition fixed wing aviation assets, and US army and/or marine indirect fire systems.

Since not all aspects of army operations, to include fire support of maneuver and other battlefield systems, can be measured quantitatively, both quantitative and qualitative analysis techniques will be used to determine the overall effectiveness of the different network structures. By accounting for the intangible aspects of army operations, this monograph will present a more balanced approach to solving the problem of how and to what extent to network fires in the BDE-level UA.

B. OUTSIDE SCOPE OF MONOGRAPH

In order to maintain the focus of the monograph, it is necessary to limit its scope. While some of the items excluded are certainly interesting and very important, they are beyond the scope of this monograph and will not be addressed in significant detail.

Beyond-line of sight (BLOS) fires are considered “an extension of traditional direct fire that extends the range to the next terrain compartment.”¹⁰ Although BLOS fires will be tracked by the network, they will not normally be controlled by the networked fires system since they are intended as a direct fire system (i.e. the firing platform and the sensor are inexorably linked),¹¹ by contrast, NLOS fires will be fully networked (both tracked *and* controlled).¹² Since networking of BLOS fires is the exception rather than the rule, the networking of those fires will not be addressed in this monograph. Networking of other direct fire systems will not be addressed either.

¹⁰ Ibid., 13.

¹¹ *TRADOC Pamphlet 525-3-90*, 4-60.

This monograph is limited to the networking of fires organic, assigned, or attached to the brigade level UA. Although the use of joint, coalition, and other external fires will be addressed, the structure of those fires' networks will not. Simplifying assumptions will be used to simulate the introduction of external fires into the brigade level UA fires network.

Non-lethal fires such as information operations (IO) and psychological operations (PSYOP) will not be addressed in this monograph due to the latency between implementation of those operations and manifestation of their effects. Since this study is concerned with tactical effects over the short term, IO and PSYOP are not relevant to the monograph. For the purposes of this monograph the effects of other non-lethal fires such as electronic warfare (EW), smoke, and non-lethal projectile delivered munitions are inherent in the simulation.

It is assumed that the effects of communication degradations will effect all networks in a roughly equal manner. Therefore, in order to simplify the design and conduct of the experiments, and to focus the monograph on the design and analysis of the fires networks, it will be assumed that communications are uninterrupted. Similarly, the effects of using different modes of communications and the susceptibility of the network to node and arc failure (robustness) will not be addressed either.

Current fires doctrine as well as emerging fires doctrine for the future force allows for the creation of quickfire channels and links to further enhance the effects of fires in certain circumstances by facilitating rapid fire mission execution. Basically, quick-fire channels create a direct link between a firing platform or unit and a sensor to enhance the responsiveness of the

¹² Ibid., 4-59.

fires.¹³ Since quick-fire channels are generally created on an adhoc basis to solve a particular problem and then just as quickly disbanded, they will not be addressed in the monograph.

III. SCENARIOS

A. Criteria

In order to determine the criteria for measuring the effectiveness of the fire support (FS) networks, it is useful to separate the problem statement into the constituent parts we are trying to optimize (either minimize or maximize). For this particular problem, that is depicted below.

Each branch of the tree will be explained in detail.

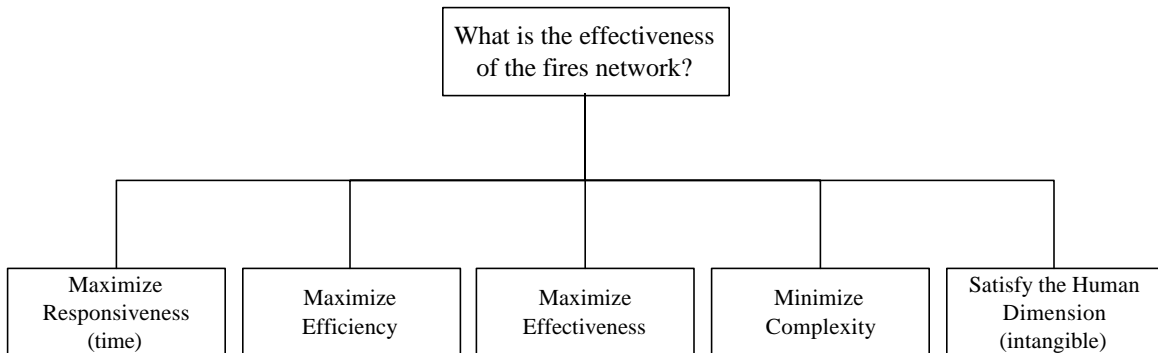

Figure 2 - Network Effectiveness Diagram

1. Responsiveness

There is a direct link between the effectiveness of fires and the responsiveness of the fires. If a call for fire is not received in a timely manner, those fires may have no effect at all and therefore be useless. By analyzing all calls for fire (CFF) in the fires system, a “smart” network can direct those fires to various firing platforms connected to the network to ensure that the time

¹³ Headquarters, Department of the Army, *FM 3-09.21: TACTICS, TECHNIQUES, AND PROCEDURES FOR THE FIELD ARTILLERY BATTALION* (Washington DC, 22 March 2001), para 5-03.

to process and execute all of the ongoing fire missions is as short as possible. This optimizes the system for timeliness.

2. Efficiency and Effectiveness

In any complex service system the efficiency and effectiveness of the system itself will inevitably be at odds. Ideally we try to satisfy both requirements by insuring that each customer gets what he needs without “shortchanging” other customers. To be absolutely efficient, no customer gets more than he needs; to be absolutely effective, no customer gets less than he needs. If we can *always* accomplish both simultaneously, we have a perfectly efficient and effective system. In most cases, however, we have to sacrifice effectiveness to maximize efficiency (i.e. *most* customers get what they need with minimal overkill) or efficiency to maximize effectiveness (i.e. *most* customers get exactly what they need, while some customers get more than they need). In the case of fires, effectiveness relates to delivering the right munitions onto each individual target in sufficient quantity to satisfy the fire mission. Efficiency relates to delivering the right amount of munitions onto the target so that no target gets more attention in the form of assets or munitions than what the fire mission calls for. The dichotomy between the two is evident in this simple example. An observer wishes to suppress a sniper behind a rock. He formulates a fire mission and requests suppressive fires. The delivery of a four artillery round volley from an NLOS platoon will suffice – it is both efficient and effective. By way of contrast, the delivery of a B-52 strike with ten 500 pound bombs is also effective, but is certainly not very efficient. Taking the example one step further illustrates the relationship between efficiency and effectiveness. Using the B-52 strike in this mission, although effective for this particular target, was wasteful and may have caused a different mission requiring a B-52 strike to be served by the four rounds from the NLOS platoon, clearly a loss of overall effectiveness.

3. Complexity

The fires network is a complex system. It can consist of hundreds of firing platforms, thousands of individual requestors and several integrating nodes – deciders – that try to satisfy all system demands based on highly complex algorithms that try to optimize the entire system. A system that is too complex may be difficult to intuitively understand and therefore to control, while one that is too simplistic may not optimize the use of assets available and waste resources. Again, an apparent tension exists. Ideally, we want a system that is easy to understand and that is capable of managing resources in an efficient manner. In terms of complexity this monograph will look at the complexity of the system mathematically as a function of nodes and arcs, and will analyze the complexity that the information processing and decision making centers or *decider* nodes are subjected to.

4. Human Dimension

Any system that deals with human beings must account for the intangible aspects that humans inevitably introduce into the problem. Habitual relationships between requestors and shooters build trust; the ability to talk to one another builds confidence and minimizes isolation. These and other factors are important considerations in determining how to network fires for the brigade level UA. They will be analyzed in detail, and will be included in the final analysis and recommendations.

B. DESIGN OF EXPERIMENT

In order to analyze the overall effect and utility of different fires network structures for the brigade UA, we can design and execute an experiment. In order to provide usable analysis, that experiment must tell us something about the systematic effects of using different network

structures, thereby giving us the information we need to optimize the network based on our criteria.

1. Design

By developing two COA's that parameterize the range of effects and one COA somewhere in the middle we can gain insight into the spectrum of effects of other COA's. At one extreme we have a completely flattened FS network (figure 3), while at the other end we have the traditional hierarchical FS network that mirrors command relationships and is typical of current forces (figure 4). Figure 5 shows a FS structure that bridges the gap. It consists of a reasonable compromise between the perceived advantages and disadvantages of the flattened and hierarchical FS structures.

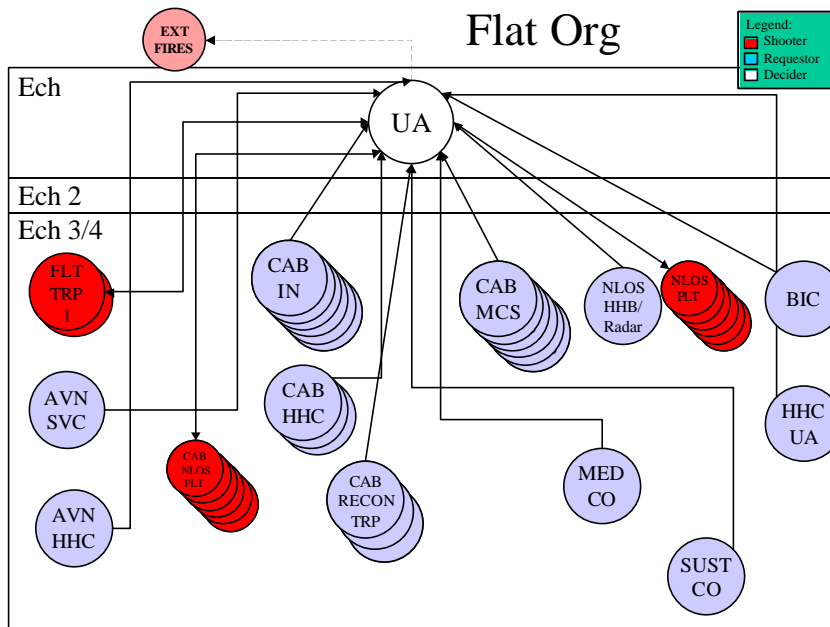

Figure 3 - Completely Flat FS Structure

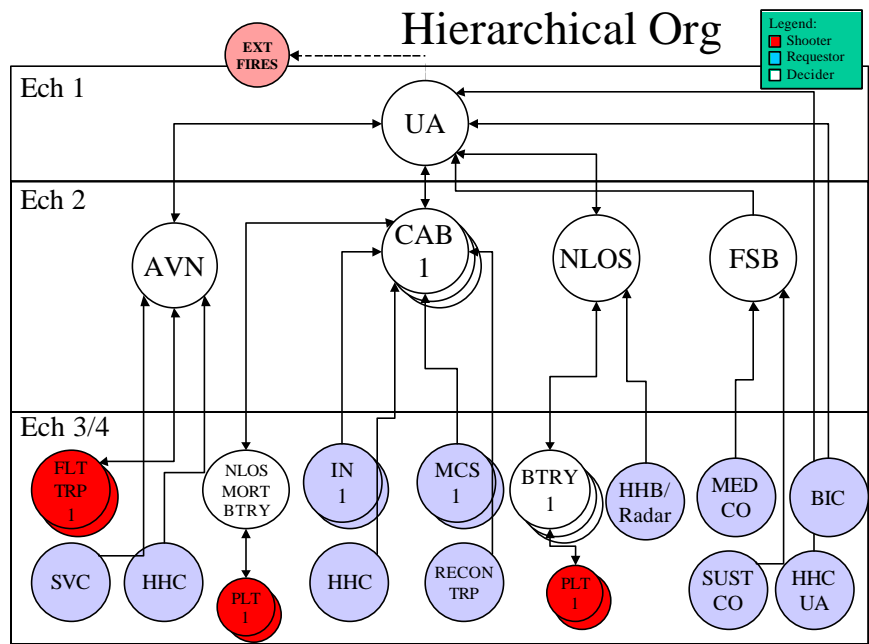

Figure 4 - Hierarchical FS Structure

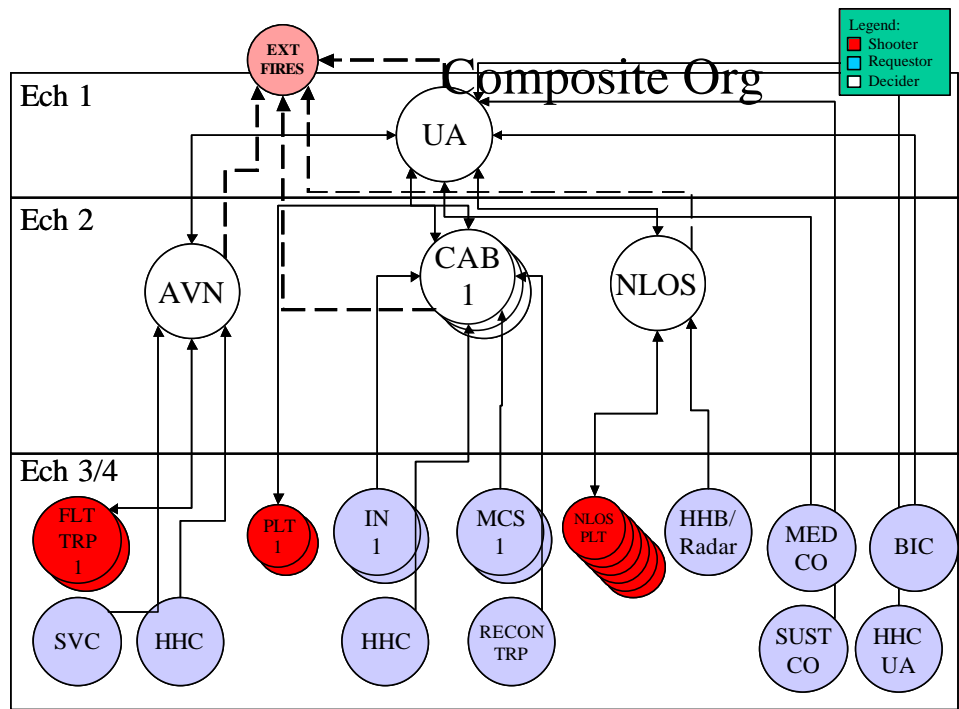

Figure 5 - Compromise between Figures 3 and 4

Now that the three COA's or scenarios have been established, it is necessary to determine the other aspect of the experimental design – the intensity of the fires requests. Since the Army is

a full spectrum force, it is reasonable to expect that the Army will employ the FS network in the full spectrum of operations. In order for the analysis and recommendations to be valid across the spectrum, the simulation and analysis must account for the effects of incorporating the network across the full spectrum of operations. Therefore, each of the three scenarios outlined above will be “tested” to account for three levels of CFF intensity – high, medium, and low. Again, these three levels of intensity are meant to parameterize the effects of the FS network in the full spectrum of operations. A table depicting the design of the experiment is shown below (table 1).

Table 1 - Experimental Design (# indicates the result of the experiment)

Network / Intensity	LOW	MEDIUM	HIGH
Hierarchical	#	#	#
Combination	#	#	#
Flat	#	#	#

2. Experiment

A total of nine experiments will be conducted. Each experiment is essentially a simulation designed to gain data to address the criteria mentioned earlier. Each network will be simulated against inputs consisting of several different types of fire missions that will be initiated by several requestors. For the low intensity experiments 5 fire missions will be initiated. For the medium and high experiments 10 and 15 fire missions will be initiated respectively. Since the total number of requestors and shooters is the same for all networks, these nodes will be numbered and the experiments for each network structure will consist of the same fire mission (FM) on the same requestor node for each intensity level. This is done to ensure that our simulation measures the changes in the network structure vice changes in where the demands are

placed on the network. Two simple visual examples are shown below (figure 6 and 7), note how FM1 is on the same requestor node for each structure in figure 6; also note how in figure 7 FM1 and FM2 are on the same requestor nodes for each structure.

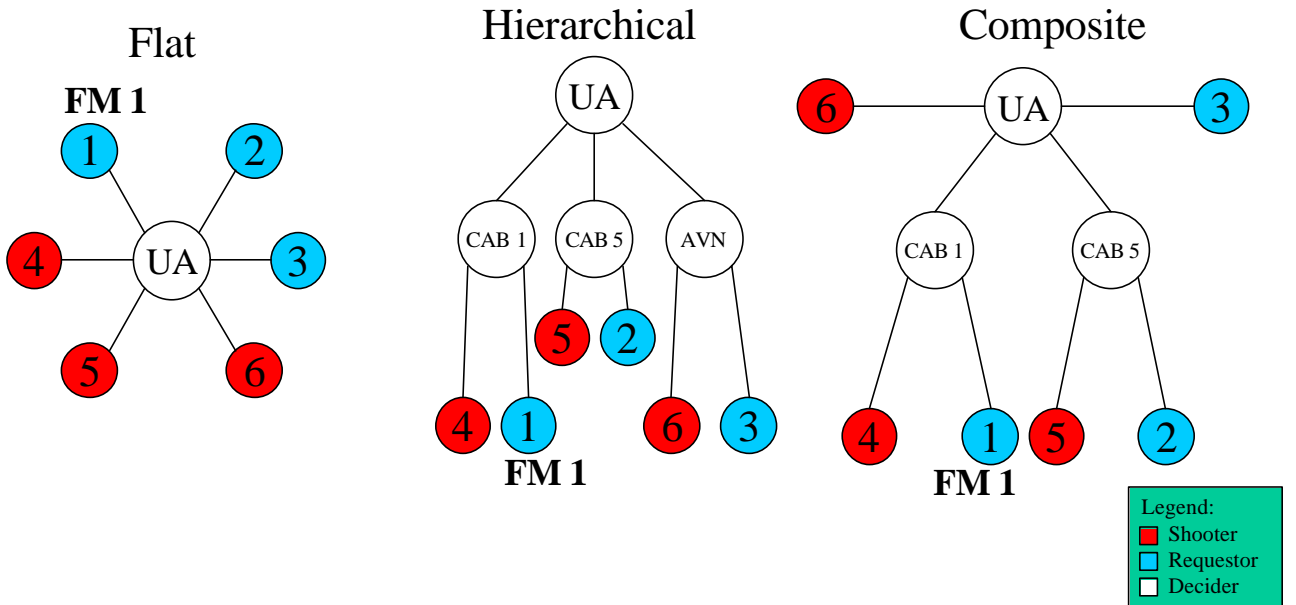

Figure 6 - Example of the experiments for low-level intensity

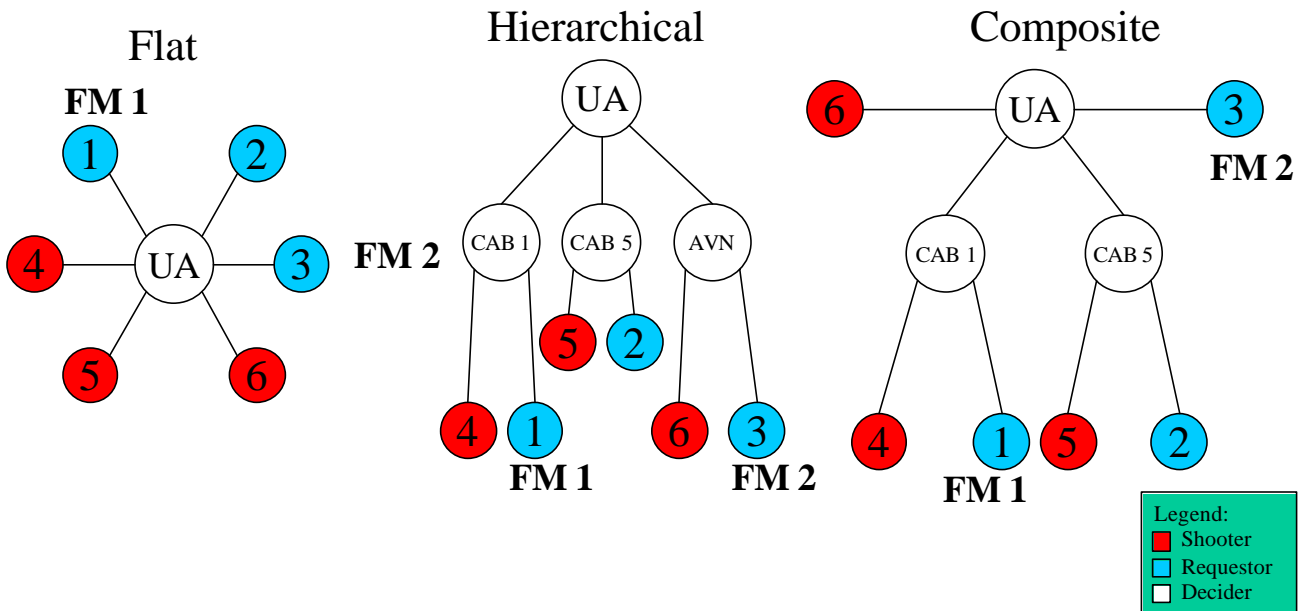

Figure 7 - Example of the experiments for mid-level intensity

To place a variety of different demands on the network, the simulation will differentiate between three different types of fire mission requests that require three different levels of fire: 1, 2, and 3. Each shooter will have a capacity to deliver fires that corresponds to its capability from 1 through 3. In order to satisfy a request for a fire mission that requires a 2, the network could give the mission two shooters with a capacity of 1, one with a capacity of 2, or one with a capacity of 3. Although excesses are inefficient, they are allowed by the system and satisfy the request. Firers cannot divide their firing capacity among fire missions (i.e. a firer with a capacity of 3 cannot service three fire missions that require a capability of 1). In other words, we can mass fires of different shooters, but cannot slice up shooter capabilities.

To represent communications latencies as well as technical and tactical mission processing times, moving along the arcs between nodes carries a time penalty. The time on the arcs will differ depending on what the arc connects. For the purposes of this monograph, arcs that cross between two echelons (see figures 3 through 5 above) will have a five-minute penalty, those that traverse three echelons will carry a seven-minute penalty, while any external fires arcs will carry a sixteen-minute penalty. These times are based on the personal experience of the authors, and were chosen because they depict a logical progression of increased processing times and communications latencies as information is passed between echelons.

In essence each experiment will consist of executing an algorithm that minimizes the total time between the request for and the execution of all fire missions while still satisfying the requirement for each fire mission. Total time for a mission will be the sum of the time along each of the arcs. For missions that call for massing fires, the total time will be the maximum time for each of the individual shooters. For example, if a mission requires a capacity of 3, and three individual shooters with a capacity of 1 respond with a delay time of five, seven, and sixteen minutes respectively, the time for the fire mission will be sixteen minutes.

IV. ANALYSIS

A. METHODOLOGY

The criteria for this monograph include five very different measures of effectiveness (MOE's) with very different values for measurement. In order to combine the MOE's into one single, consistent value, we will use a multi-attribute utility model (MAUM). MAUM is based on two primary assumptions: 1) MOE's are independent of their complements (e.g. in our case if we determine that timeliness is more important than efficiency, this relationship must hold regardless of how high or low the values of any of the other MOE's are) and 2) The utility of each MOE is independent of its complement (i.e. that we can place the relative rank of any two MOE's independent of the other MOE's).¹⁴

In order to determine the utility of an individual data set we must compare values from our data set. The “worst” or least desirable value assumes a utility of 0, while the “best” or most desirable value assumes a utility of 1. The remaining data points assume values between 0 and 1 based on a function determined by the experimenter.¹⁵ For the purposes of our analysis, we will assume a linear function. The resultant utility function looks like this, where we determine the worst, and the data determines the best (i = MOE, j = intensity):

$$\text{Utility Score } MOE_{i,j} = (x_{i,j} - \text{worst}_{i,j}) / (\text{best}_{i,j} - \text{worst}_{i,j}), \text{ for } \forall i, j$$

Since our data set is very limited (only three values per MOE to account for the flat, hierarchical, and composite COA's), this analysis will deviate from MAUM slightly in that we will personally determine the data point that represents a utility of 0 based on personal experience

¹⁴ John R. Canada and William G. Sullivan, *Economic Multiattribute Evaluation of Advanced Manufacturing Systems* (Englewood Cliffs: Prentice Hall, 1989), 244-245.

and judgment. This is done so that the analysis will not be skewed by the small number of observations we have. For example, if the results of our experiment yield the following three total fire mission times in seconds– 10,000, 10,001, and 10,002; adhering strictly to the MAUM methodology would yield the following respective utilities: 0.0, 0.5, 1.0. By setting the value for 0 utility at 5,000 seconds we would get the following utilities: 0.9996, 0.9998, and 1.0000. The raw MOE data generically depicted by the #'s in the following table will be analyzed against the corresponding data in each column to determine the utility for each MOE under a given intensity level.

Table 2 - Table of raw MOE data for each COA under each intensity level

MOE COA	Timeliness	Effectiveness	Efficiency	Complexity	Human Factor
Flat	#	#	#	#	#
Hierarchical	#	#	#	#	#
Composite	#	#	#	#	#
Judgment- Based “Worst”	#	#	#	#	#

To determine the overall utility of a particular COA under a particular intensity level, the individual utilities for each MOE will be weighted and combined. Two basic assumptions must be met when weighting the relative value of each attribute or MOE:

1. It must be possible for the decision maker to consider and judge the relative weight of any combination of factors. That is, it must be possible to consider not only the weight of factor 1 (F_1), but also the weight of both F_1 and F_2 .

¹⁵ Ibid., 254-255.

2. Weights are assumed to be additive. That is, given the weight of F_1 and the weight of F_2 , the weight of both F_1 and F_2 is the sum of their individual weights.¹⁶

Once the weights have been determined, then the overall utility of each given COA under the given intensity level can be calculated using the following expression (where i = MOE, j = intensity, k = COA, and v = weight):

$$U(k)_j = \left[\sum_{i=1}^N v_{ij} * U(k_{ij}) \right]_j, \text{ for } \forall i,j,k$$

Now that we have the individual utilities for each COA under a given intensity level we can determine the overall utility of the COA by weighting the intensity levels and combining the utilities from above using the same assumptions listed above. The following expression illustrates how this is done (where j = intensity, w = weight, and k = COA):

$$U(k) = \sum_{j=1}^N w_j * U(k)_j, \text{ for } \forall j,k$$

The final utility scores then reflect the overall utility of each COA based on the weights given to each MOE and the weights given to each intensity level.

B. PRESENTATION AND ANALYSIS OF PROCESSED DATA

1. Experimental Data

The results of the experiment were derived by simulating the network's behavior using a shortest path algorithm as part of several optimization programs which are listed in appendix 3¹⁷.

¹⁶ Ibid., 223.

¹⁷ In order to get the data presented here, the output from the shortest path algorithm was analyzed in depth to find the shortest paths for each fire mission. My numbers differ from the GAMS optimization software output for the following reasons: 1) The algorithm found the shortest path and charged the "cost"

Overall, the experimental results were not surprising – at all intensity levels, the most timely network was the flat one, second was the composite network, and last was the hierarchical network. All structures tested displayed equal efficiency and effectiveness as defined earlier.

a. Responsiveness

Although the flat structure yielded the shortest overall timeliness over the entire intensity spectrum, in all cases, the composite structure provided the most timely fires for what would traditionally have been direct support (DS) type missions from organic assets (such as mortars). An example showing the pathways for a DS mission from the CAB recon troop to the CAB NLOS fires is shown below.

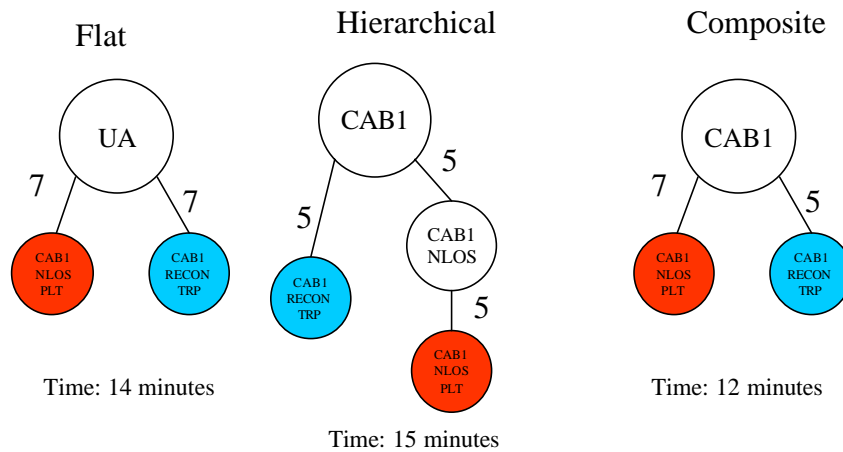

Figure 8 - DS Mission Flow

Since the Flat structure must traverse more than one level of command for each arc, additional time is required to adjudicate and clear each mission. In the hierarchical case we

to each individual unit of capacity (NLOS platoon = 3, aviation = 2, external assets = 3) passed along the path. We manually adjudicated this. 2) Because of how the algorithm worked, massing fires resulted in adding time for each individual firer, when in actuality the total time used overlapped, again we adjudicate this by hand. 3) The algorithm could not distinguish between massing firing units on targets and splitting capabilities out of individual packages, due to an excess supply of firing assets, we could adjudicate this by hand with no loss in efficiency.

traverse only one level of command with each mission, but must traverse three vice two nodes. In the composite case we gain timeliness by reducing the number of nodes traversed and maintaining the entire mission within CAB1. Where the flat structure is most effective is in streamlining the fires process when fires external to the CAB, such as the UA NLOS battalion or fires external to the UA, are required. The flat structure does this so well that it is more timely overall for all intensity levels.

Timeliness gains for the composite and flat structure over the hierarchical structure are not linear. The raw and normalized timeliness results are shown in table 3.

Table 3 - Normalized Changes to Timeliness

		Low	Medium	High
Raw Time	Flat	70	149	244
	Composite	75	165	264
	Hierarchical	90	191	284
Adjusted as percent (Flat = 100%)	Flat	100.0%	100.0%	100.0%
	Composite	107.1%	110.7%	108.2%
	Hierarchical	128.6%	128.2%	116.4%

Since the flat structure is the most centralized and has an omnipotent view of the fire missions and the assets available, it would seem to follow that the higher the intensity the bigger the timeliness gains. The results of the experiment, however, do not support this claim. At the highest intensity level, the relative difference in timeliness is smallest compared to the hierarchical structure and a very close second compared to the composite structure. A complete study of this non-monotonic behavior is beyond the scope of the monograph, but suggests that there is a limit to the responsiveness gains provided by a flattened structure. One possible explanation is that this limitation is the result of limited resources. The theory is that when resources are stretched to the limit and all available assets are needed, the flat network structure

runs out of options or ways to minimize responsiveness – it reaches the limits of its efficiency.

This behavior should be studied in more detail.

b. Efficiency and effectiveness

All of the fire support network structures displayed equal effectiveness and efficiency as defined in the design of the experiment. This occurred for two reasons. First, the optimization program used takes advantage of system-wide global knowledge to produce an optimal solution with respect to the objective function – in this case minimization of total time for executing all of the fire missions. Since sufficient resources were available to satisfy all requirements – our definition of effectiveness, effectiveness never became an issue. Second, in all three network structures using external fires was the least responsive means of delivering fires. Because of this, each networked in effect “solved” the problem of providing responsive fires using own resources before asking for additional help. Efficiency only became an issue when the only available assets had more firepower than was needed. Since all three networks had global knowledge, had access to the same limited resources, and operated under similar rules for requesting external fires, efficiency was the same across the board.

2. Other Data

a. Complexity

Systems complexity is not bad. In fact according to at least one theorist, complex systems that are exemplified by “a great many independent agents [that] are interacting with each other in a great many ways,”¹⁸ all undergo spontaneous self-organization and are highly adaptive. The very nature of their interactions enables them to readily adapt and self-organize. One such

system is the stock market. It continually self-organizes to bring the market into equilibrium. The trade-off for this self-organizing characteristic is that the behavior of the stock market, a complex system, is difficult if not impossible to consistently predict with any degree of accuracy. While self-organizing behavior certainly has its merits, when designing a system to produce something; such as timely, efficient, and effective fires; predictability allows us to manipulate the system to get the desired results. Assuming that the fire system is already part of a complex system – a deployed military force – our goal is not to enhance its self-adaptive nature, but to produce predictable results with the assets available. Therefore, by minimizing the complexity of the decisions that must be made and the network as a whole we can maximize predictability. This enhances our ability to make good decisions and to tailor the system for a very specific purpose.

There are two major aspects relating to complexity, both of which are in tension, that will be covered. They are the complexity of the network structure as a whole and the complexity associated with the individual “decider” nodes – those nodes that determine how the fire missions should be routed. We will weight each of these two aspects equally and use the MAUM as outlined earlier to combine the two different versions of complexity.

- Complexity of the FS Network as a Whole.

The complexity of the FS network as a whole is based on how simple or difficult it is to find an optimal pathway between a node requesting a fire mission and one providing those fires. Intuitively we can look at several networks and tell which one is the most complex. In order to quantify what we know intuitively, let us look at why one appears more complex than another. Let us assume that the number of nodes, arcs, and their interactions determine the complexity of the network. The simple example shown below shows that three networks with 4 nodes each can

¹⁸ Mitchell M. Waldrop, *Complexity, The Emerging Science at the Edge of Order and Chaos* (New

have different complexities based on the number of arcs, which dictate the interactions among the nodes.

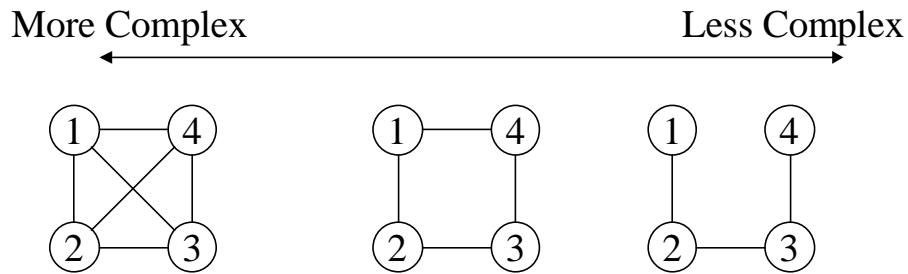

Figure 9 - Example of three systems with four nodes that have different complexities

Similarly, we can create three networks with six arcs each that have different complexities based on the number of nodes they each have. Again, the interactions determine the complexity.

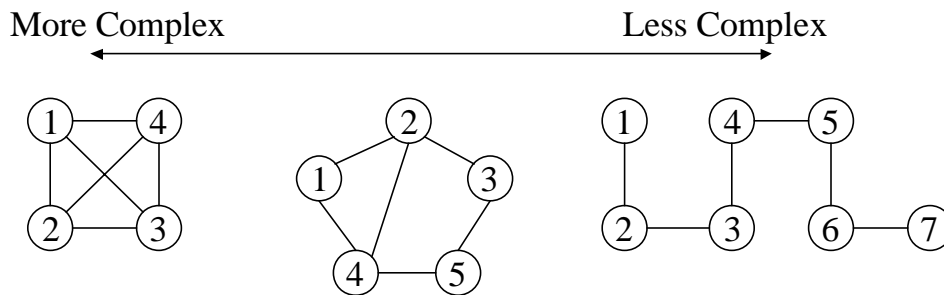

Figure 10 - Example of three systems with six arcs that have different complexities

Let us study what makes each of the networks above more or less complex. In figure 9, complexity is a matter of more arcs. The more arcs there are, the more pathways we have to analyze to find the “best” one. Here it is obvious, the higher the number of arcs, the more complex the network. The example in figure 10 however confuses us. Here, keeping the number of arcs constant while increasing the number of nodes makes the network *less* complex.

York, NY: Simon and Schuster, 1992), 11.

Assuming you cannot go through a node more than once, by comparing the two least complex networks in both cases we find that there is exactly one path from node one to node four in figure 9 and exactly one path from node one to node seven in figure 10. By contrast, in the most complex network there are 5 possible paths from node one to node four (1-4, 1-2-4, 1-3-4, 1-2-3-4, 1-3-2-4). What we have attempted to portray here is that complexity is dependent upon the number of nodes and arcs. If we assume that complexity is the number of arcs divided by the number of nodes, we can test this hypothesis with our two figures. From left to right for figure 9, the complexity is $6/4 = 1.5$, $4/4 = 1.0$, and $3/4 = 0.75$. From left to right for figure 10, the complexity is $6/4 = 1.5$, $6/5 = 1.2$, and $6/7 \approx 0.86$. Again, using this method to compare the least complex networks in figure 9 and 10 we notice that the network in figure 10 has a complexity about 0.86 while the one in figure 9 has a complexity of 0.75. Intuitively we can see that the network in figure 10 is more complex, which this formula confirms for us. By no means have we performed a formal proof to determine complexity. What we hope we have done however is develop a method that has been shown to work heuristically.

Using this heuristic to calculate the complexity for the networks used in the experiment (figures 3, 4, and 5) we get the following:

Flat: $44/45 \approx 0.978$, Composite: $49/50 = 0.980$, Hierarchical: $56/57 \approx 0.982$

The trend here seems to be that the total number of nodes is one more than the number of arcs (i.e. if arcs = x, then complexity = $x/(x+1)$). If we make x extremely large, it is easy to see that the complexity gets closer and closer to 1, which gives us the theoretically worst case complexity for this part of the analysis. Using this as the basis for applying the multi-attribute utility model explained earlier ($Utility = (x_{i,j} - worst_{i,j}) / (best_{i,j} - worst_{i,j})$) we get the utilities shown in table 4 below.

- Decider Node Complexity.

When a decider node contemplates who should get what fire mission, it analyzes the current situation and picks the best firing unit based on the fire mission request and the current situation. To make that decision the decider must account for things such as timeliness, range from shooter to target, effects of weather and terrain, the urgency of the mission, available ammunition, and much more. Additionally, that node must ensure that those fires are cleared across the battlespace to avoid fratricide. The smaller the amount of information the decider node has to consider, the less complex his task will be. It then follows that a decider node at the CAB level has less complexity to deal with than one at the next higher level since he has fewer assets to contend with, and has a smaller box of terrain to contend with. In terms of the fire support network, the more hierarchical a structure is the more decider nodes it has. These structures therefore compartmentalize information as well as control. The net effect is that the complexity associated with each decider node is lower than a flatter structure. For example, when a CAB pushes a mission higher, the UA no longer must consider using the CAB's assets. The fact that the CAB asked for help from the outside allows the UA to do this. Additionally, instead of analyzing the remainder of the battlespace, the UA can simply poll the other decider nodes and focus his analysis on the external assets and any clearance of fires issue for which he has responsibility. Clearly then, the hierarchical structure is the least complex, followed by the composite structure and then the flat structure. The metric we will use to measure the complexity of each structure is based on the number of decider nodes (more decider nodes yields less complexity). A high number of decider nodes indicates a decentralized decision-making structure, with less complexity involved for each decision-making node who accounts for mainly local variables. A lower number of decider nodes indicates a more centralized and complex decision-making structure with decisions being made by only a few empowered nodes who must account for a large number of variables. The number of decider nodes for the flat, composite, and hierarchical structure are 1, 6, and 13 respectively. Using 1 as the worst case, and 13 as the best case yields the utility shown in table 4 below.

Combining the two utilities for complexity calculated earlier and giving each equal weight yields the overall utility of the structure with respect to complexity. This is shown in the table below.

Table 4 - Utility based on Network Complexity

Structure	Structure Complexity	Decider Node Complexity	Overall Utility
Flat	1.000	0.000	0.500
Composite	0.909	0.417	0.663
Hierarchical	0.818	1.000	0.909

b. Human Dimension

Former Army Chief of Staff Creighton Abrams said:

The Army is not made up of people; the Army is people... living, breathing, serving human beings. They have needs and interests and desires. They have spirit and will, strengths and abilities. They have weaknesses and faults, and they have means. They are the heart of our preparedness...and this preparedness—as a nation and as an Army – depends upon the spirit of our soldiers. It is the spirit that gives the Army...life. Without it we cannot succeed.¹⁹

The human dimension of warfare is perhaps the most difficult to understand and hence the most difficult to model. We will highlight what we believe to be some of the more important issues regarding the human dimension and how they are affected by the three different networks structures. The human dimension issues that will be analyzed include team building, expectations, and isolation. Based on this qualitative analysis and personal experience we will assign a utility to the three different structures.

¹⁹ Headquarters, Department of the Army, *FM 22-100: Army Leadership* (Washington DC, 31 August 1999), 3-1.

Habitual relationships between supported and supporting units are an important part of building effective fighting teams. By training together, units and soldiers learn to work together and thereby develop cohesion and trust, the foundations of team building and esprit de corps. FM 7-0 says “Teams can only achieve combined arms proficiency and cohesiveness when they train together.”²⁰ Cohesive units develop synergy; mutual trust allows them undertake dangerous operations with the knowledge that their brothers in arms will be there to provide support and assistance at the critical time and place. The Army recognizes that units fight as they have trained, which is why FM 7-0 emphasizes “the training fundamental that combined arms teams will train as they fight.”²¹

By developing habitual relationships and training together soldiers and units develop expectations of one another. Those expectations include mutual presence on the battlefield, a shared mission – which may include sharing risk and danger, a minimum level of proficiency, and more. Units that train together develop shared expectations based on their training. Units that do not train together do not have those shared expectations which leads to misunderstandings and may lead to a shirking of responsibilities – it is far easier to break faith with strangers than to do the same with friends and partners.

One of the effects of technology has been that the battlefield has expanded. Units and people have become more and more physically dispersed to mitigate against the effects of today’s highly lethal weapons and weapon systems. Communications and automation technology have enabled this dispersion by allowing us to interact over long distances. A byproduct of this dispersion is the psychological isolation of soldiers on the battlefield. Soldiers’ feeling of

²⁰ Headquarters, Department of the Army, *FM 7-0 Training the Force* (Washington DC, 22 October 2002), para 2-9.

isolation contributes to depression and lowered morale. Professor Schneider of the School for Advanced Military Studies (SAMS) goes so far as to say “In isolation and desolation, the soldier faces the yawning abyss of the empty battlefield; threatening to engulf him in the black jaws of moral destruction.”²² Training together and maintaining human to human voice vice digital contact helps to relieve feelings of isolation.

We will rate each of the three scenarios based on the three human dimensions discussed – teambuilding, expectations, and isolation. We will then combine the ratings to determine the final rating for each scenario in terms of the human dimension.

With regard to team building, the flat structure is probably the least desirous. The flat scenario tries to optimize efficiency and effectiveness by removing humans from the decision-making process. It determines the “best” firing solution based on variables such as time, efficiency, and effectiveness. With this sort of arrangement it may be difficult to know who is on your team at any particular moment, because your fire support team is based on who can best satisfy the constraints of the optimal solution. It can be argued that the flat structure focuses the team building at the UA or brigade level. This argument becomes flawed when it is confronted by the UA concept which is built upon the foundation of modular combined arms units, such as the CAB, within the UA that are self sufficient. Overall, the hierarchical and composite organizations are very similar in the aspect of team building. Both “build” the team at the battalion level; their differences manifest themselves mostly in how fires are managed at the battalion level. In light of the following analysis, we will assign a utility of 0.40 to the flat structure and 1.00 to the composite and hierarchical structures.

²¹ Ibid.,para 3-29.

For the same reason that team building suffers under the flat structure, expectations suffer as well. Although CAB's will almost certainly train together, the knowledge that those fire support units might not be there to deliver fires for their respective organizations will be ever present. Competing demands that are adjudicated by a central node seeking to optimize timeliness, efficiency, and effectiveness may undermine expectations developed by training together and the organizational structure that implies organic fires assets at battalion level. This may, however, be mitigated due to battalions inevitably still training together as combined arms teams. Again, the hierarchical and composite structures show not significant differences in this aspect for the same reasons outlined above. Based on this analysis and personal experience we have assigned the flat structure a utility of 0.85 and the composite and hierarchical structures a utility of 1.00 with respect to expectations.

In terms of isolation, again the flat structure suffers because of its reliance on optimizing non-human factors. The flat structure isolates soldiers and units more than ever. Because of how the structure determines who fires for who, automated and digital systems become even more relied upon. Although voice linkages will still exist, the complexity of the adjudication process, particularly when fire mission volume is high, may minimize what the human at the other end of the line is able to do. When considering optimization under the flat structure it must be kept in mind that this structure optimizes timeliness, efficiency, and effectiveness across the UA. What may be an optimal solution for the UA, may fall well short of what is required for an individual unit under certain circumstances. Imagine a scenario from the movie *To Hell and Back*. Audie Murphy is in dire straits and needs artillery fires. "Murphy, playing himself, calls-for-fire,

²² James J. Schneider, "The Theory of the Empty Battlefield" *RUSI: Journal of the Royal United Services Institute for Defence Studies* September 1987), 43.

implored the fire direction center (FDC) to 'Tell them Joes to get the lead out.'"²³ The bantering back and forth between Audie Murphy and the artillery fire direction center (FDC) painted a vivid picture of the situation and the necessity for the immediate priority of fires he needed and received. Under the new optimized, flat networked structure Audie Murphy does not even know who to call to talk to the FDC. He sends a digitally formatted message and gets the following response: "Our network automation is optimizing fires across the UA. We don't know how it does this, but rest assured everyone will get their fair share, including you!" Will this response reassure Audie Murphy that he is anything more than a nug in a huge wheel?

Because of the removal of many of the intermediate nodes under the composite structure, there are in effect less humans in the loop. This may contribute to feelings of isolation since the human to human contact will be minimized. Based on this analysis we have assigned a utility to the flat, composite, and hierarchical structures of 0.85, 0.90, and 1.00 respectively.

If we assumed equal weighting for each of the above criteria we can combine the utilities to get an overall utility. Combining the utility scores yields the following respective scores for the flat, composite and hierarchical structures: 2.10, 2.90, and 3.00. Since the utilities used must be between 0 and 1, we must normalize this result by converting the highest one (3.00) to 1 and the others to lower values in an equal ratio. We do this by dividing each value by the highest value (3.00). The result of normalizing the utilities above yields the following respective scores for the flat, composite and hierarchical structures: 0.70, 0.97, and 1.00.

²³ Gary H. Cheek, "Why Can't Joe Get the Lead Out?" *Field Artillery Journal* (January-February 2003), 33.

3. Multi-Attribute Utility Model

Once all of the data was collected, the multi-attribute utility model (MAUM) was used to convert the raw data to utilities and then combine the individual utilities for each MOE using weights. This was done for each level of intensity, because the importance, and hence weight, of each of the MOE's could differ depending on the situation which was broadly modeled by intensity.

For the low intensity case, the weights used were as follows: timeliness = 35%, effectiveness = 15%, efficiency = 15%, complexity = 15%, human dimension = 20%. These weights were based on my personal judgment and then were used as a baseline for determining the weights for the medium and high intensity level cases. Table 5 below shows the raw MOE data from the analysis above as well as the weights that were chosen for each MOE. As explained in the methodology section, we assigned a worst case for each MOE to account for the small data set the experiment and analysis produced and to preclude the worst case data point from being given a utility of 0. Due to the outcome of the experiment and the method in which the other MOE's were analyzed, the only MOE affected by this personal judgment was timeliness. We assumed that the worst case for timeliness should be 5 minutes per fire mission longer than the best case. This amounted to adding 25 minutes to the best case under low intensity conditions, 50 minutes under medium intensity conditions, and 75 minutes under high intensity conditions.

Table 5 - Raw MOE Data (low intensity)

MOE COA	Timeliness	Effectiveness	Efficiency	Complexity	Human Factor
Flat	70	1	1	0.50	0.70
Hierarchical	90	1	1	0.909	1.00
Composite	75	1	1	0.663	0.97
Judgment- Based “Worst”	95	1	1	0.000	0.0
Weight	35%	15%	15%	15%	20%

Once the raw data was consolidated, MAUM was applied to it to get the utility for the low intensity case shown below.

Table 6 - Utility of each structure under Low Intensity

MOE COA	Timeliness	Effective- ness	Efficiency	Complexity	Human Factor	Total
Flat	0.350	0.150	0.150	0.075	0.140	0.865
Hierarchical	0.070	0.150	0.150	0.136	0.200	0.706
Composite	0.280	0.150	0.150	0.099	0.194	0.873

Based on the analysis from above and the weights applied, the results indicate that the composite structure has the most utility under low intensity conditions. Clearly, the reasons that the composite structure slightly edges out the flat structure is due to the advantages in the MOE’s concerning complexity and human dimension. Still, the flat structure is a close second while the hierarchical structure is a distant third.

Under medium intensity the weights were adjusted. As the volume of fires increases, simplicity becomes more important to overcome the increased friction of a stressed system. Raising the weight of the complexity MOE accounts for this. Since complexity assumed more importance, one or more other MOE’s must become less important. For the medium intensity

case, timeliness was the bill payer for this increase. The re-weighting of the baseline is as follows: timeliness = 30%, effectiveness = 15%, efficiency = 15%, complexity = 20%, human dimension = 20%. Table 7 below shows the raw MOE data from the analysis above as well as the weights that were chosen for each MOE.

Table 7 - Raw MOE Data (medium intensity)

MOE COA	Timeliness	Effectiveness	Efficiency	Complexity	Human Factor
Flat	149	1	1	0.500	0.70
Hierarchical	191	1	1	0.909	1.00
Composite	165	1	1	0.663	0.97
Judgment- Based “Worst”	199	1	1	0.000	0.0
Weight	30%	15%	15%	20%	20%

Once the raw data was consolidated, MAUM was applied to it to get the utility for the medium intensity case shown below.

Table 8 - Utility of each structure under Medium Intensity

MOE COA	Timeliness	Effective- ness	Efficiency	Complexity	Human Factor	Total
Flat	0.300	0.150	0.150	0.100	0.140	0.840
Hierarchical	0.048	0.150	0.150	0.182	0.200	0.730
Composite	0.204	0.150	0.150	0.133	0.194	0.831

Based on the analysis from above and the weights applied, the results indicate that the flat structure has the most utility under medium intensity conditions. Here we can see that the large timeliness gains of the flat structure under the higher number of fire missions outweighed all other considerations. Still, the composite structure is a close second, while again, the hierarchical structure is a distant third.

Under the high intensity case the weights were once again adjusted. In order to be able to satisfy all fire missions, efficiency assumes more importance. For the same reasons sighted under the medium case, complexity was weighted higher as well. The bill payers for these increases were timeliness and effectiveness. The re-weighting of the baseline is as follows: timeliness = 25% effectiveness = 10%, efficiency = 20%, complexity = 25%, human dimension = 20%. Table 9 below shows the raw MOE data from the analysis above as well as the weights that were chosen for each MOE.

Table 9 - Raw MOE Data (high intensity)

MOE COA	Timeliness	Effectiveness	Efficiency	Complexity	Human Factor
Flat	244	1	1	0.500	0.70
Hierarchical	284	1	1	0.909	1.00
Composite	264	1	1	0.663	0.97
Judgment- Based "Worst"	319	1	1	0.000	0.0
Weight	25%	10%	20%	25%	20%

Once the raw data was consolidated, MAUM was applied to it to get the utility for the high intensity case shown below.

Table 10 - Utility of each structure under High Intensity

MOE COA	Timeliness	Effective- ness	Efficiency	Complexity	Human Factor	Total
Flat	0.250	0.100	0.200	0.125	0.140	0.815
Hierarchical	0.117	0.100	0.200	0.227	0.200	0.844
Composite	0.183	0.100	0.200	0.166	0.194	0.843

Based on the analysis from above and the weights applied, the results indicate that the hierarchical structure has the most utility under high intensity conditions. Here the added importance of complexity and efficiency coupled with the reduced importance of timeliness and effectiveness resulted in the hierarchical structure being the best. The composite structure was very close, and the flat structure was not much worse either.

C. CONCLUSIONS

Combining the utilities for each individual case gives us the total utility of each structure, which can easily be normalized. Those results are shown in table 11 below.

Table 11 - Overall Utility of each COA/Structure

	Total Utility	Normalized Utility
Flat	2.520	0.989
Composite	2.547	1.000
Hierarchical	2.280	0.895

The results indicate that the composite structure was the overall superior COA, but the flat structure is only 1.1% “worse.” Since only a single data point was taken and analyzed for each MOE under each case, we cannot analyze the statistical significance of this small difference. Since the hierarchical structure is significantly behind the other two we can probably safely assume that the other two are superior to it overall. It is important to note that based on the weighting and analysis done each structure had strengths and interestingly assumed a leading role under the three scenarios. The most consistent performer, however, was the composite structure (see figure 11 below). It is important to keep in mind that the results of this analysis depend heavily on the weights selected for each MOE as well as the equal weighting given each of the scenarios. What the analysis tells us is that each of the COA’s has inherent strengths and weaknesses which should be at least considered before any decision is made to chose one over the

other. Overall the analysis provides some insight into how the system works and that occur within the system.

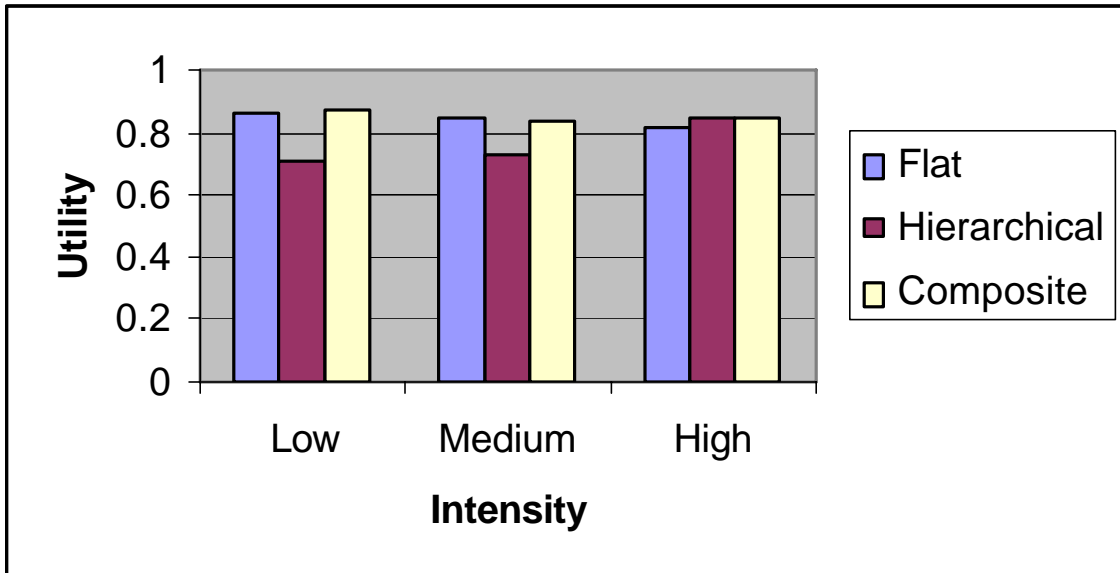

Figure 11 - Graph of Utility over Intensity

The analysis indicates that the composite structure is the most consistent across all scenarios and excels under the low intensity case. Based on the analysis, we would invest more research into developing and analyzing the middle-ground of different composite structures vice the extremes exemplified by the flat and hierarchical structures.

V. CONCLUSIONS AND RECOMMENDATIONS

A. Conclusions

Vice Admiral Arthur Cebrowski's theory of NCW is based on a similar business model that led to enormous gains in efficiency and productivity by optimizing profit. The example Cebrowski used from business centered on the value of information as a way of locking the competition out of the market, and served as a model for an analogous concept for waging network-centric warfare. This monograph studied the implications of extending the joint,

operational concept of NCW to the tactical level for the army; with an emphasis on exploring which fires structures are best suited to take advantage of the NCW concept.

This monograph studied three different structures for the UA fires network; those three structures became the COA's used in the analysis. In an attempt to bound the realm of relevant structures, a completely flat structure and a hierarchical structure that mimics the task organization were devised to represent the extreme limits for the network. A middle-ground was also chosen to establish a median structure we called the composite structure. We used five MOE's – responsiveness, effectiveness, efficiency, complexity, and human dimension – to evaluate each of the COA's against three different fire mission intensity levels – low, medium, and high. The MAUM was used to combine the results of the objective and subjective analysis of each of the MOE's for each intensity level yielding an objective utilitarian value for each COA under a particular level of intensity. The MAUM was used once more to combine the intensity level scores into one utility value for the entire COA.

The results suggest that all three networking structures studied have their own particular niche strengths. Through the careful design of a composite fires network the negative effects of the flat and hierarchical structures can be mitigated while retaining some of the advantages of both. The composite structure is not simply a compromise; in some cases the composite structure can actually improve on inefficiencies inherent in the flat and hierarchical structures. Overall, the most fertile area for research in fires networking structures appears to be in the area of composite structures that can exploit the advantages of both the flat and hierarchical structures while still making improvements in other areas that the other two are weak.

One simple example concerns the human dimension and responsiveness of direct support fires. The completely flat structure tends to separate the fires delivery system from the sensor or user by introducing a centralized information processing and decision-making center, while the hierarchical structure, mirroring command relationships, has decision-making centers at every

level responsible for adjudicating fires as well as maintaining unit cohesion and fighting capability. Both of these structures, however, exhibit rather slow responsiveness to calls for direct support fires. The flat structure suffers from having to adjudicate and assign fires across multiple echelons while the hierarchical structures is encumbered by inefficiencies due to too many intermediate decision centers. The composite structure used for this monograph eliminates a small number of redundant or inefficient decision-making centers, which detracts slightly from its effectiveness in managing the human dimension of warfare, but actually improves on the responsiveness of direct support fires over the hierarchical and flat structures. In effect the composite structure develops its own niche in direct support responsiveness due to inefficiencies inherent in the other two structures for a relatively small trade-off in managing the human dimension.

The overall analysis with respect to the individual evaluation criterion –responsiveness, efficiency, effectiveness, complexity, and human dimension – yielded some interesting results. A summary of those results follows:

Responsiveness. The experiment indicated that flatter networks are more responsive overall in providing fires. A closer look at the data reveals that while responsiveness was optimized for the system, it did little to improve timeliness for direct support fires. Interestingly, as the number of fire missions increases, the timeliness gains over the hierarchical structure diminish. No clear pattern emerged for timeliness gains over the composite structure. In all cases of fire mission intensity, the flat structure provided the most responsiveness, the composite was second, and the hierarchical structure was third.

Efficiency and effectiveness. Efficiency and effectiveness were a wash across the entire experiment. Since all three network structures had global knowledge of the system and had the same resources available, they were able to allocate fires with equal levels of efficiency as well as effectiveness.

Human Dimension. The human dimension related to fires and warfighting suffers as the fire support structure flattens due to centralized decision-making, automation, and shifting of emphasis from habitual relationships to responsiveness, efficiency, and effectiveness. Flatter structures centralize decision-making thereby distancing the decision maker from the impact of his or her decisions. This distance is further compounded by fewer operations centers that must handle and process more technical and tactical fires data. The result is increased automation that removes human to human contact. Finally, habitual relationships lose importance as the emphasis is shifted to satisfying fire mission requirements with the best available shooter.

Complexity. Complexity issues are twofold – structural and nodal. Since there are fewer nodes and fewer arcs, structural complexity goes down as the network becomes flatter. Simultaneously, however, nodal complexity increases as the information processing and decision-making nodes decrease in number. Fewer information processing and decision-making nodes must now handle the same amount of information, resulting in more complex decisions at each center. Overall, the effect of flattening the structure *increases* complexity.

In the final analysis, the concept of networking fires has promise at the tactical level. This exploratory study indicates that completely flat and completely hierarchical networks are *not* the optimal networks at the tactical level. Composite fires structures seem to offer the most consistent and in many cases the best results for networking brigade-level fires.

B. Issues.

1. Parameters for the Experiment

While this monograph studied the effectiveness of several different network structures for fires, it is important to keep in mind that the parameters for the experiment that were chosen to represent fire mission delay times between echelons were chosen because they were reasonable and were based on the authors' years of experience in the military and in the field of combat

modeling. The optimization process was extremely sensitive to the parameters chosen. For instance, we used 16 minutes to represent the time delay between a call for fire and delivery of those fires by an external source – air, naval gunfire, etc. – resulting in those assets being used as a last resort in all three COA’s. If we had used 10 minutes for that particular parameter, those same external assets would have been used much more frequently for the composite and hierarchical structures; they would have made little if any difference for the completely flat structure.

2. MAUM

The multi-attribute utility model is dependent upon the weighting of the MOE’s to determine utility. We chose the weights based on our personal experience and biases. Again, the results of this monograph were dependent upon the parameters chosen for weighting among the MOE’s and among the different intensity levels. Different weights could yield very different results.

C. Recommendations.

This monograph has provided one possible answer – exploitation of the middle-ground – to a highly complex problem. As with many studies, this analysis created more questions than it answered which form the basis for our recommendations for further research. First and foremost, the basic research question merits further study to bring different perspectives to bear on the problem which can only add to a more complete understanding of the issues involved. Further research should focus on bounding the solution even further and drawing an even more complete picture of possible solution sets. Some other related areas that should be studied follow.

1. Quick-fire Channels.

This monograph did not address the implications of establishing quick-fires channels. A quick-fire channel is a temporary linkage created between a sensor and a firer to address a particular tactical problem. They are generally used to provide more responsive fires for special mission sensors such as radars, but could be created within the networked fires concept to focus the fires effort in a particular sector that is considered a hotspot or with a particular unit that is the UA main effort. Further study of how quick-firer channels can and should be used within the networked fires concept would help to optimize the structure based on emerging doctrine.

2. Limits to Responsiveness Gains from Flattening the Network

The responsiveness gains of the completely flat network over the hierarchical and composite networks in this study lessened with the increased number of fire missions. A related observation indicated the possibility of non-monotonic behavior of the flat network's responsiveness gains over the hierarchical network. Further study in these areas should address whether those observations were random or followed a particular pattern. We recommend a study similar to this one be initiated with an approach that involves stochastic simulation to get a distribution of results. Such a study would provide more data and allow more in-depth statistical analysis of fires networks. In short, it would provide more information for decision-making.

3. Efficiency and Effectiveness

Efficiency and effectiveness were a wash in this monograph. We suspect this is partially due to the deterministic nature of the model used. Again, we recommend a study similar to this one be initiated with an approach that involves stochastic simulation to get a distribution of results. A stochastic simulation would be a better tool to determine the differences, if any, in effectiveness and efficiency of different structures.

4. Optimizing Locally versus Globally.

For our purposes this experiment optimized responsiveness, effectiveness, and efficiency *globally* by finding the “best” overall solution for the brigade-level UA. *Global* optimization however, is a matter of perspective – certainly those MOE’s were not optimized for the brigade-level UA’s higher or lower headquarters. Future studies should analyze where the network should optimize for different variables. Arguably, we may be able to optimize the effects for the entire system by locally optimizing for responsiveness which *could* lead to globally optimizing for the effects on the human dimension.

GLOSSARY

AO	area of operations
BCS	battle command system
BIC	brigade intelligence and communications
BLOS	beyond line of sight
CAB	combined arms battalion
CFF	call for fire
CO	company
COA	course of action
DS	direct support
EW	electronic warfare
FAS	feasible, acceptable, suitable
FF	future force
FM	fire mission
FS	fire support
HHB	headquarters and headquarters battery
HHC	headquarters and headquarters company
IO	information operations
LOS	line of sight
MAUM	multi-attribute utility model
MCS	mounted combat system
MOE	measure of effectiveness
NCW	network-centric warfare
NLOS	non-line of sight
OODA	observe orient decide act
PSYOP	psychological operations
UA	unit of action

APPENDIX 1 - Task Organization Of Brigade-Level Unit of Action²⁴

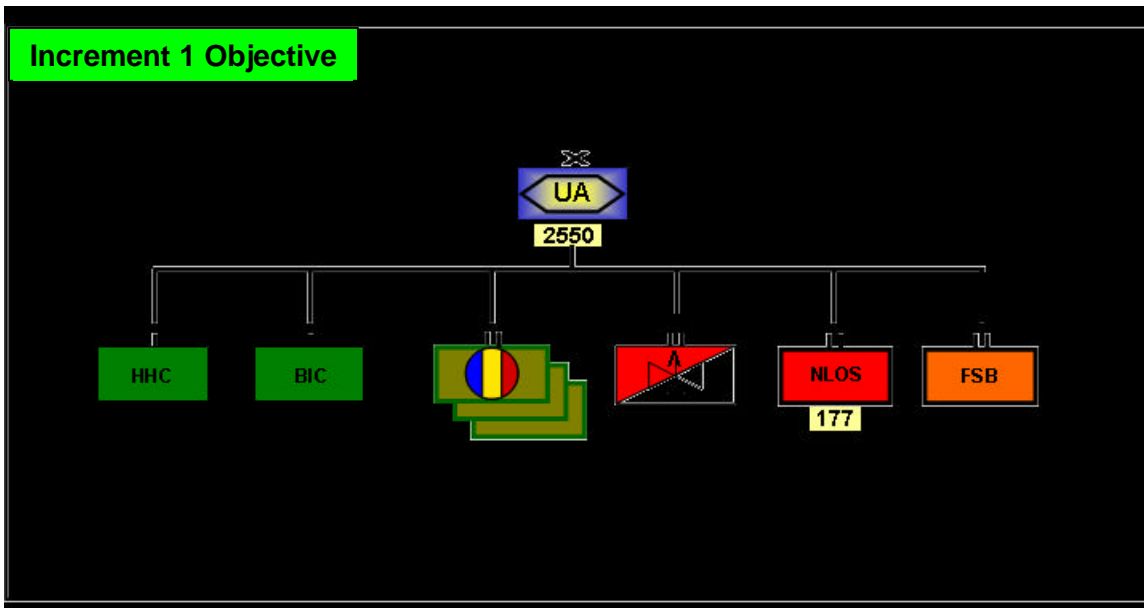

APPENDIX 2 – Experiment Static and Dynamic Variables

Annex A – Node table and experimental design

Unit Name	Node		COA			Demand on each Node based on intensity level		
	Name	Capacity	Flat	Hier	Comp	Low	Med	High
HQ, UA	N1	-	X	X	-	-	-	-
HHC	N2	-	X	X	-	-	-	1
BIC CO	N3	-	X	X	-	-	-	-
HQ, AVN SQN	N4	-	-	X	-	-	-	-
HHC	N5	-	X	X	-	-	2	2
SVC CO	N6	-	X	X	-	-	-	2
FLT CO 1	N7	2	X	X	-	-	-	-
FLT CO 2	N8	2	X	X	-	-	-	-
HQ, CAB1	N9	-	-	X	-	-	-	-
HHC	N10	-	X	X	-	-	2	2
RECON TRP	N11	-	X	X	-	1	1	1
IN CO1	N12	-	X	X	-	-	1	1
IN CO2	N13	-	X	X	-	-	1	1

²⁴ TRADOC Pamphlet 525-3-9, 31

Unit Name	Node		COA			Demand on each Node based on intensity level		
	Name	Capacity	Flat	Hier	Comp	Low	Med	High
MCS CO1	N14	-	X	X	-	-	-	-
MCS CO2	N15	-	X	X	-	-	-	-
NLOS BTRY	N16	-	-	X	-	-	-	-
PLT1	N17	1	X	X	-	-	-	-
PLT2	N18	1	X	X	-	-	-	-
HQ, CAB2	N19	-	-	X	-	-	-	-
HHC	N20	-	X	X	-	-	-	1
RECON TRP	N21	-	X	X	-	-	-	-
IN CO1	N22	-	X	X	-	-	-	-
IN CO2	N23	-	X	X	-	2	2	2
MCS CO1	N24	-	X	X	-	3	3	3
MCS CO2	N25	-	X	X	-	-	-	-
NLOS BTRY	N26	-	-	X	-	-	-	-
PLT1	N27	1	X	X	-	-	-	-
PLT2	N28	1	X	X	-	-	-	-
HQ, CAB3	N29	-	-	X	-	-	-	-
HHC	N30	-	X	X	-	-	-	2
RECON TRP	N31	-	X	X	-	-	-	1
IN CO1	N32	-	X	X	-	-	-	-
IN CO2	N33	-	X	X	-	-	-	-
MCS CO1	N34	-	X	X	-	-	3	3
MCS CO2	N35	-	X	X	-	-	-	-
NLOS BTRY	N36	-	-	X	-	-	-	-
PLT1	N37	1	X	X	-	-	-	-
PLT2	N38	1	X	X	-	-	-	-
HQ, NLOS BN	N39	-	-	X	-	-	-	-
HHC	N40	-	X	X	-	1	1	1
BTRY1	N41	-	-	X	-	-	-	-
PLT1	N42	1	X	X	-	-	-	-
PLT2	N43	1	X	X	-	-	-	-
BTRY2	N44	-	-	X	-	-	-	-
PLT1	N45	1	X	X	-	-	-	-
PLT2	N46	1	X	X	-	-	-	-
BTRY3	N47	-	-	X	-	-	-	-
PLT1	N48	1	X	X	-	-	-	-
PLT2	N49	1	X	X	-	-	-	-
HQ, FSB	N50	-	-	X	-	-	-	-
SUST CO	N51	-	X	X	-	2	2	2
MED CO	N52	-	X	X	-	-	-	-
EXTERNAL FIRES 1	N53	3	X	X	X	-	-	-
EXTERNAL FIRES 2	N54	3	X	X	X	-	-	-
EXTERNAL FIRES 3	N55	3	X	X	X	-	-	-
EXTERNAL FIRES 4	N56	3	X	X	X	-	-	-
EXTERNAL FIRES 5	N57	3	X	X	X	-	-	-

Annex B – Network Arc-Node List with times to travel along arcs

FLAT			HIERARCHICAL			COMPOSITE		
NODE		TIME	NODE		TIME	NODE		TIME
Start	End		Start	End		Start	End	
1	7	7	1	4	5	1	4	5
1	8	7	1	9	5	1	9	5
1	17	7	1	19	5	1	19	5
1	18	7	1	29	5	1	29	5
1	27	7	1	39	5	1	39	5
1	28	7	1	53	15	1	53	15
1	37	7	1	54	15	1	54	15
1	38	7	1	55	15	1	55	15
1	42	7	1	56	15	1	56	15
1	43	7	1	57	15	1	57	15
1	45	7	2	1	5	2	1	5
1	46	7	3	1	5	3	1	5
1	48	7	4	1	5	4	1	5
1	49	7	4	7	5	4	7	5
1	53	7	4	8	5	4	8	5
1	54	7	5	4	5	5	4	5
1	55	7	6	4	5	6	4	5
1	56	7	7	4	5	7	4	5
1	57	7	8	4	5	8	4	5
2	1	5	9	1	5	9	1	5
3	1	5	9	16	5	9	17	7
5	1	7	10	9	5	9	18	7
6	1	7	11	9	5	10	9	5
7	1	7	12	9	5	11	9	5
8	1	7	13	9	5	12	9	5
10	1	7	14	9	5	13	9	5
11	1	7	15	9	5	14	9	5
12	1	7	16	9	5	15	9	5
13	1	7	16	17	5	17	9	7
14	1	7	16	18	5	18	9	7
15	1	7	17	16	5	19	1	5
17	1	7	18	16	5	19	27	7
18	1	7	19	1	5	19	28	7
20	1	7	19	26	5	20	19	5
21	1	7	20	19	5	21	19	5
22	1	7	21	19	5	22	19	5
23	1	7	22	19	5	23	19	5
24	1	7	23	19	5	24	19	5
25	1	7	24	19	5	25	19	5
30	1	7	25	19	5	27	19	7
31	1	7	26	19	5	28	19	7
32	1	7	26	27	5	29	1	5
33	1	7	26	28	5	29	37	7
34	1	7	27	26	5	29	38	7
35	1	7	28	26	5	30	29	5
37	1	7	29	1	5	31	29	5
38	1	7	29	16	5	32	29	5

FLAT			HIERARCHICAL			COMPOSITE		
NODE		TIME	NODE		TIME	NODE		TIME
Start	End		Start	End		Start	End	
40	1	7	30	29	5	33	29	5
42	1	7	31	29	5	34	29	5
43	1	7	32	29	5	35	29	5
45	1	7	33	29	5	37	29	7
46	1	7	34	29	5	38	29	7
48	1	7	35	29	5	39	1	5
49	1	7	36	29	5	39	42	7
51	1	7	36	37	5	39	43	7
52	1	7	36	38	5	39	45	7
			37	36	5	39	46	7
			38	36	5	39	48	7
			39	1	5	39	49	7
			39	41	5	40	39	5
			39	44	5	42	39	7
			39	47	5	43	39	7
			40	39	5	45	39	7
			41	39	5	46	39	7
			41	42	5	48	39	7
			41	43	5	49	39	7
			42	41	5	51	1	7
			43	41	5	52	1	7
			44	39	5			
			44	45	5			
			44	46	5			
			45	44	5			
			46	44	5			
			47	39	5			
			47	48	5			
			47	49	5			
			48	47	5			
			49	47	5			
			50	1	5			
			51	50	5			
			52	50	5			

Annex C – Flat Network Structure Diagram with arc and node values and node names

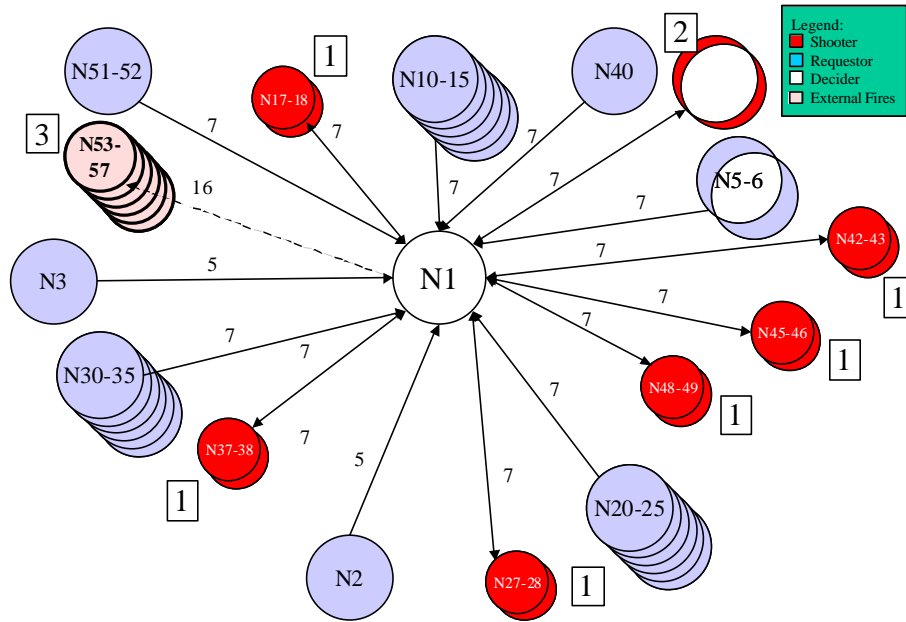

Annex D – Hierarchical Network Structure with arc and node values and node names

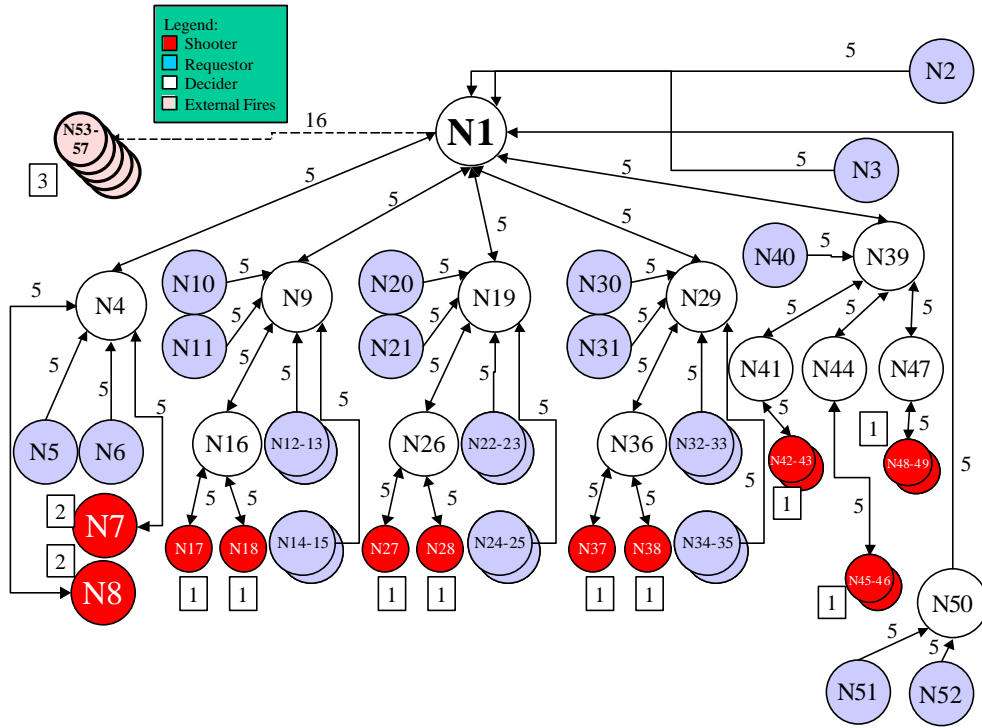

Annex E – Composite Network Structure with arc and node values and node names

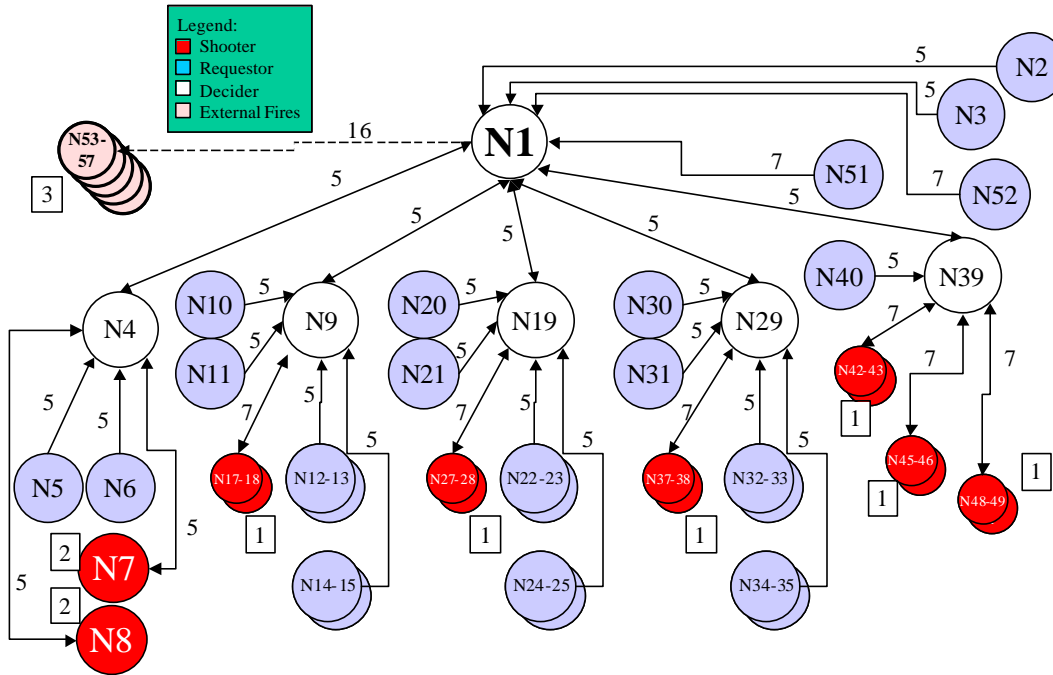

APPENDIX 3 – Programming and Output Data

Annex A – Program and Output Data for Flat Structure w/ Low Intensity

GAMS Rev 133 Windows NT/95/98 01/13/04 09:20:43 Page 1
 General Algebraic Modeling System
 Compilation

```

1 *-----
2 OPTIONS RESLIM = 100, ITERLIM = 1000
3     LIMCOL = 0, LIMROW = 0, DECIMALS = 2
4     SOLPRINT = OFF, LP = XA;
5 *-----
6 SET
7   i      nodes in the network /N0*N57/
8   arc(i,i)  arcs in the network
9   /N0.N7, N0.N8, N0.N17,
10  N0.N18, N0.N27, N0.N28,
11  N0.N37, N0.N38, N0.N42,
12  N0.N43, N0.N53, N0.N54,
13  N0.N55, N0.N56, N0.N57,
14  N1.N7, N1.N8, N1.N17,
15  N1.N18, N1.N27, N1.N28,
16  N1.N37, N1.N38, N1.N42,
17  N1.N43, N1.N45, N1.N46,
18  N1.N48, N1.N49, N1.N53,
19  N1.N54, N1.N55, N1.N56,
20  N1.N57, N2.N1, N3.N1,
    
```

```

21 N5.N1, N6.N1, N7.N1,
22 N8.N1, N10.N1, N11.N1,
23 N12.N1, N13.N1, N14.N1,
24 N15.N1, N17.N1, N18.N1,
25 N20.N1, N21.N1, N22.N1,
26 N23.N1, N24.N1, N25.N1,
27 N30.N1, N31.N1, N32.N1,
28 N33.N1, N34.N1, N35.N1,
29 N37.N1, N38.N1, N40.N1,
30 N42.N1, N43.N1, N45.N1,
31 N46.N1, N48.N1, N49.N1,
32 N51.N1, N52.N1 /;
33 *-----
34 ALIAS
35 (i,j);
36 *-----
37 PARAMETERS

```

Node N0 serves to take up slack within the network. By putting all slack demand on N0 and then linking it with all demand nodes and giving those arcs a cost of zero, forces the program to find the shortest paths for all other demands first and then use the slack demand to balance the equations.

```

46
47 cost (i,j)   arc length
48 / N0.N7 = 0, N0.N8 = 0, N0.N17 = 0,
49 N0.N18 = 0, N0.N27 = 0, N0.N28 = 0,
50 N0.N37 = 0, N0.N38 = 0, N0.N42 = 0,
51 N0.N43 = 0, N0.N53 = 0, N0.N54 = 0,
52 N0.N55 = 0, N0.N56 = 0, N0.N57 = 0,
53 N1.N7 = 7, N1.N8 = 7, N1.N17 = 7,
54 N1.N18 = 7, N1.N27 = 7, N1.N28 = 7,
55 N1.N37 = 7, N1.N38 = 7, N1.N42 = 7,
56 N1.N43 = 7, N1.N45 = 7, N1.N46 = 7,
57 N1.N48 = 7, N1.N49 = 7, N1.N53 = 16,
58 N1.N54 = 16, N1.N55 = 16, N1.N56 = 16,
59 N1.N57 = 16, N2.N1 = 5, N3.N1 = 16,
60 N5.N1 = 7, N6.N1 = 7, N7.N1 = 7,
61 N8.N1 = 7, N10.N1 = 7, N11.N1 = 7,
62 N12.N1 = 7, N13.N1 = 7, N14.N1 = 7,
63 N15.N1 = 7, N17.N1 = 7, N18.N1 = 7,
64 N20.N1 = 7, N21.N1 = 7, N22.N1 = 7,
65 N23.N1 = 7, N24.N1 = 7, N25.N1 = 7,
66 N30.N1 = 7, N31.N1 = 7, N32.N1 = 7,
67 N33.N1 = 7, N34.N1 = 7, N35.N1 = 7,
68 N37.N1 = 7, N38.N1 = 7, N40.N1 = 7,
69 N42.N1 = 7, N43.N1 = 7, N45.N1 = 7,
70 N46.N1 = 7, N48.N1 = 7, N49.N1 = 7,
71 N51.N1 = 7, N52.N1 = 7 /
72
73 b(i)         vector of supplies and demands
74 / N7 = -2, N8 = -2, N17 = -1, N18 = -1, N27 = -1, N28 = -1,
75 N37 = -1, N38 = -1, N42 = -1, N43 = -1, N45 = -1, N46 = -1,
76 N48 = -1, N49 = -1, N53 = -3, N54 = -3, N55 = -3, N56 = -3,

```

```

77   N57 = -3, N11 = 1, N23 = 2, N24 = 3, N40 = 1, N51 = 2,
78   N0 = 22;
79   *-----
80 POSITIVE VARIABLE
81   X(i,j)    amount of flow on each arc;
82 VARIABLE
83   TOTALTIME    total time to satisfy all fire missions;
84   *-----
85 EQUATIONS
86   OBJ          define objective function
87   FLOWBAL(i)   flow conservation;
88   *-----
89   OBJ..        TOTALTIME =E= SUM(arc,cost(arc)*X(arc));
90   FLOWBAL(i).. SUM(arc(i,j),X(i,j))-SUM(arc(j,i),X(j,i)) =E= b(i)
91   *-----
92 MODEL FIREMISSIONFLOW /ALL/;
93 FIREMISSIONFLOW.OPTFILE = 1;
94 SOLVE FIREMISSIONFLOW USING LP MINIMIZING TOTALTIME;
95 DISPLAY TOTALTIME.L,X,L;

```

COMPILATION TIME = 0.000 SECONDS 0.8 Mb WIN207-133

MODEL STATISTICS

BLOCKS OF EQUATIONS	2	SINGLE EQUATIONS	47
BLOCKS OF VARIABLES	2	SINGLE VARIABLES	72
NON ZERO ELEMENTS	199		

GENERATION TIME = 0.000 SECONDS 1.6 Mb WIN207-133

EXECUTION TIME = 0.000 SECONDS 1.6 Mb WIN207-133

S O L V E S U M M A R Y

```

MODEL FIREMISSIONFLOW OBJECTIVE TOTALTIME
TYPE LP                DIRECTION MINIMIZE
SOLVER XA              FROM LINE 94

```

```

**** SOLVER STATUS 1 NORMAL COMPLETION
**** MODEL STATUS 1 OPTIMAL
**** OBJECTIVE VALUE 126.0000

```

```

RESOURCE USAGE, LIMIT 0.000 100.000
ITERATION COUNT, LIMIT 4 1000

```

GAMS/XA Jun 14, 2002 WIN.XA.XA 20.7 011.024.040.VIS

Memory estimate (computed): 0.56MB

Copyright (c) 2000, 2001 by SUNSET SOFTWARE TECHNOLOGY.
1613 Chelsea Road, Suite 153
San Marino, California 91108 U.S.A.
All Rights Reserved Worldwide.

Telephone 626-441-1565 FAX 626-441-1567
 EMAIL: jim@sunsetsoft.com
 http://www.sunsetsoft.com

Licensed Solely To: GAMS DEVELOPMENT CORPORATION - 1208802
 WASHINGTON, DC

STATISTICS - gams Tue Jan 13 09:20:43 2004
 xa VERSION 13.68 NT DLL USABLE MEMORY 0.5 MBYTE
 ENV ID 1 SOLVE NUMBER 1
 VARIABLES 72
 0 LOWER, 0 FIXED, 0 UPPER, 1 FREE
 CONSTRAINTS 48
 0 GE, 47 EQ, 0 LE, 1 NULL/FREE, 0 RANGED.
 200 NON-ZEROS WORK 45,774
 MINIMIZATION.
 GAMS DEVELOPMENT CORPORATION - 1208802
 WASHINGTON, DC

**** REPORT SUMMARY : 0 NONOPT
 0 INFEASIBLE
 0 UNBOUNDED

95 VARIABLE TOTALTIME.L = 126.00 total time to satisfy
 all fire missions

---- 95 VARIABLE X.L amount of flow on each arc

	N1	N7	N8	N17	N18	N27
N0				1.00	1.00	
N1		2.00	2.00	1.00		
N11	1.00					
N23	2.00					
N24	3.00					
N40	1.00					
N51	2.00					

95 VARIABLE X.L amount of flow on each arc

	N28	N37	N38	N42	N43	N45
N0	1.00	1.00	1.00	1.00	1.00	
N1					1.00	

95 VARIABLE X.L amount of flow on each arc

	N46	N48	N49	N53	N54	N55
N0			3.00	3.00	3.00	
N1	1.00	1.00	1.00			

95 VARIABLE X.L amount of flow on each arc

+ N56 N57
N0 3.00 3.00

EXECUTION TIME = 0.050 SECONDS 1.6 Mb WIN207-133

USER: Michael R. Anderson G030318:1008CP-WIN
US Army TRAC, Joint Analysis Division DC904

**** FILE SUMMARY

INPUT C:\WINDOWS\GAMSDIR\FLAT_LOW.GMS
OUTPUT C:\WINDOWS\GAMSDIR\FLAT_LOW.LST

Annex B – Program and Output Data for Flat Structure w/ Medium Intensity

GAMS Rev 133 Windows NT/95/98 01/13/04 09:22:06 Page 1
General Algebraic Modeling System
Compilation

```
1 *-----  
2 OPTIONS RESLIM = 100, ITERLIM = 1000  
3   LIMCOL = 0, LIMROW = 0, DECIMALS = 2  
4   SOLPRINT = OFF, LP = XA;  
5 *-----  
6 SET  
7   i      nodes in the network /N0*N57/  
8   arc(i,i) arcs in the network  
9   /N0.N7, N0.N8, N0.N17,  
10  N0.N18, N0.N27, N0.N28,  
11  N0.N37, N0.N38, N0.N42,  
12  N0.N43, N0.N53, N0.N54,  
13  N0.N55, N0.N56, N0.N57,  
14  N1.N7, N1.N8, N1.N17,  
15  N1.N18, N1.N27, N1.N28,  
16  N1.N37, N1.N38, N1.N42,  
17  N1.N43, N1.N45, N1.N46,  
18  N1.N48, N1.N49, N1.N53,  
19  N1.N54, N1.N55, N1.N56,  
20  N1.N57, N2.N1, N3.N1,  
21  N5.N1, N6.N1, N7.N1,  
22  N8.N1, N10.N1, N11.N1,  
23  N12.N1, N13.N1, N14.N1,  
24  N15.N1, N17.N1, N18.N1,  
25  N20.N1, N21.N1, N22.N1,  
26  N23.N1, N24.N1, N25.N1,  
27  N30.N1, N31.N1, N32.N1,  
28  N33.N1, N34.N1, N35.N1,
```

```

29   N37.N1, N38.N1, N40.N1,
30   N42.N1, N43.N1, N45.N1,
31   N46.N1, N48.N1, N49.N1,
32   N51.N1, N52.N1 /;
33 *-----
34 ALIAS
35 (i,j);
36 *-----
37 PARAMETERS

```

Node N0 serves to take up slack within the network. By putting all slack demand on N0 and then linking it with all demand nodes and giving those arcs a cost of zero, forces the program to find the shortest paths for all other demands first and then use the slack demand to balance the equations.

```

46
47 cost (i,j)   arc length
48 / N0.N7 = 0,  N0.N8 = 0,  N0.N17 = 0,
49   N0.N18 = 0,  N0.N27 = 0,  N0.N28 = 0,
50   N0.N37 = 0,  N0.N38 = 0,  N0.N42 = 0,
51   N0.N43 = 0,  N0.N53 = 0,  N0.N54 = 0,
52   N0.N55 = 0,  N0.N56 = 0,  N0.N57 = 0,
53   N1.N7 = 7,  N1.N8 = 7,  N1.N17 = 7,
54   N1.N18 = 7,  N1.N27 = 7,  N1.N28 = 7,
55   N1.N37 = 7,  N1.N38 = 7,  N1.N42 = 7,
56   N1.N43 = 7,  N1.N45 = 7,  N1.N46 = 7,
57   N1.N48 = 7,  N1.N49 = 7,  N1.N53 = 16,
58   N1.N54 = 16,  N1.N55 = 16,  N1.N56 = 16,
59   N1.N57 = 16,  N2.N1 = 5,  N3.N1 = 16,
60   N5.N1 = 7,  N6.N1 = 7,  N7.N1 = 7,
61   N8.N1 = 7,  N10.N1 = 7,  N11.N1 = 7,
62   N12.N1 = 7,  N13.N1 = 7,  N14.N1 = 7,
63   N15.N1 = 7,  N17.N1 = 7,  N18.N1 = 7,
64   N20.N1 = 7,  N21.N1 = 7,  N22.N1 = 7,
65   N23.N1 = 7,  N24.N1 = 7,  N25.N1 = 7,
66   N30.N1 = 7,  N31.N1 = 7,  N32.N1 = 7,
67   N33.N1 = 7,  N34.N1 = 7,  N35.N1 = 7,
68   N37.N1 = 7,  N38.N1 = 7,  N40.N1 = 7,
69   N42.N1 = 7,  N43.N1 = 7,  N45.N1 = 7,
70   N46.N1 = 7,  N48.N1 = 7,  N49.N1 = 7,
71   N51.N1 = 7,  N52.N1 = 7 /
72
73 b(i)         vector of supplies and demands
74 / N7 = -2,  N8 = -2,  N17 = -1,  N18 = -1,  N27 = -1,  N28 = -1,
75   N37 = -1,  N38 = -1,  N42 = -1,  N43 = -1,  N45 = -1,  N46 = -1,
76   N48 = -1,  N49 = -1,  N53 = -3,  N54 = -3,  N55 = -3,  N56 = -3,
77   N57 = -3,  N11 = 1,  N23 = 2,  N24 = 3,  N40 = 1,  N51 = 2,
78   N5 = 2,  N10 = 2,  N12 = 1,  N13 = 1,  N34 = 3,  N0 = 13/;
79 *-----
80 POSITIVE VARIABLE
81 X(i,j)       amount of flow on each arc;
82 VARIABLE
83 TOTALTIME   total time to satisfy all fire missions;
84 *-----

```

```

85 EQUATIONS
86 OBJ      define objective function
87 FLOWBAL(i)  flow conservation;
88 *-----
89 OBJ..      TOTALTIME =E= SUM(arc,cost(arc)*X(arc));
90 FLOWBAL(i)..  SUM(arc(i,j),X(i,j))-SUM(arc(j,i),X(j,i)) =E= b(i)
91 *-----
92 MODEL FIREMISSIONFLOW /ALL/;
93 FIREMISSIONFLOW.OPTFILE = 1;
94 SOLVE FIREMISSIONFLOW USING LP MINIMIZING TOTALTIME;
95 DISPLAY TOTALTIME.L,X.L;

```

COMPILATION TIME = 0.060 SECONDS 0.8 Mb WIN207-133

MODEL STATISTICS

```

BLOCKS OF EQUATIONS  2  SINGLE EQUATIONS  47
BLOCKS OF VARIABLES  2  SINGLE VARIABLES  72
NON ZERO ELEMENTS   199

```

GENERATION TIME = 0.000 SECONDS 1.6 Mb WIN207-133

EXECUTION TIME = 0.000 SECONDS 1.6 Mb WIN207-133

S O L V E S U M M A R Y

```

MODEL FIREMISSIONFLOW OBJECTIVE TOTALTIME
TYPE LP      DIRECTION MINIMIZE
SOLVER XA    FROM LINE 94

```

```

**** SOLVER STATUS  1 NORMAL COMPLETION
**** MODEL STATUS  1 OPTIMAL
**** OBJECTIVE VALUE      270.0000

```

```

RESOURCE USAGE, LIMIT  0.000  100.000
ITERATION COUNT, LIMIT  10     1000

```

GAMS/XA Jun 14, 2002 WIN.XA.XA 20.7 011.024.040.VIS

Memory estimate (computed): 0.56MB

Copyright (c) 2000, 2001 by SUNSET SOFTWARE TECHNOLOGY.
1613 Chelsea Road, Suite 153
San Marino, California 91108 U.S.A.
All Rights Reserved Worldwide.
Telephone 626-441-1565 FAX 626-441-1567
EMAIL: jim@sunsetsoft.com
<http://www.sunsetsoft.com>

Licensed Solely To: GAMS DEVELOPMENT CORPORATION - 1208802
WASHINGTON, DC

STATISTICS - gams Tue Jan 13 09:22:06 2004
 xa VERSION 13.68 NT DLL USABLE MEMORY 0.5 MBYTE
 ENV ID 1 SOLVE NUMBER 1
 VARIABLES 72
 0 LOWER, 0 FIXED, 0 UPPER, 1 FREE
 CONSTRAINTS 48
 0 GE, 47 EQ, 0 LE, 1 NULL/FREE, 0 RANGED.
 200 NON-ZEROS WORK 45,774
 MINIMIZATION.
 GAMS DEVELOPMENT CORPORATION - 1208802
 WASHINGTON, DC

**** REPORT SUMMARY : 0 NONOPT
 0 INFEASIBLE
 0 UNBOUNDED

95 VARIABLE TOTALTIME.L = 270.00 total time to satisfy
 all fire missions

--- 95 VARIABLE X.L amount of flow on each arc

	N1	N7	N8	N17	N18	N27
N1		2.00	2.00	1.00	1.00	1.00
N5	2.00					
N10	2.00					
N11	1.00					
N12	1.00					
N13	1.00					
N23	2.00					
N24	3.00					
N34	3.00					
N40	1.00					
N51	2.00					

95 VARIABLE X.L amount of flow on each arc

	N28	N37	N38	N42	N43	N45
N1	1.00	1.00	1.00	1.00	1.00	1.00

95 VARIABLE X.L amount of flow on each arc

	N46	N48	N49	N53	N54	N55
N0			1.00	3.00	3.00	
N1	1.00	1.00	1.00	2.00		

95 VARIABLE X.L amount of flow on each arc

	N56	N57
N0	3.00	3.00

EXECUTION TIME = 0.000 SECONDS 1.6 Mb WIN207-133

USER: Michael R. Anderson G030318:1008CP-WIN
US Army TRAC, Joint Analysis Division DC904

**** FILE SUMMARY

INPUT C:\WINDOWS\GAMSDIR\FLAT_MED.GMS
OUTPUT C:\WINDOWS\GAMSDIR\FLAT_MED.LST

Annex C – Program and Output Data for Flat Structure w/ High Intensity

GAMS Rev 133 Windows NT/95/98 01/13/04 09:33:30 Page 1
General Algebraic Modeling System
Compilation

```
1 *-----  
2 OPTIONS RESLIM = 100, ITERLIM = 1000  
3     LIMCOL = 0, LIMROW = 0, DECIMALS = 2  
4     SOLPRINT = OFF, LP = XA;  
5 *-----  
6 SET  
7   i      nodes in the network /N0*N57/  
8   arc(i,i)  arcs in the network  
9     /N0.N7, N0.N8, N0.N17,  
10    N0.N18, N0.N27, N0.N28,  
11    N0.N37, N0.N38, N0.N42,  
12    N0.N43, N0.N53, N0.N54,  
13    N0.N55, N0.N56, N0.N57,  
14    N1.N7, N1.N8, N1.N17,  
15    N1.N18, N1.N27, N1.N28,  
16    N1.N37, N1.N38, N1.N42,  
17    N1.N43, N1.N45, N1.N46,  
18    N1.N48, N1.N49, N1.N53,  
19    N1.N54, N1.N55, N1.N56,  
20    N1.N57, N2.N1, N3.N1,  
21    N5.N1, N6.N1, N7.N1,  
22    N8.N1, N10.N1, N11.N1,  
23    N12.N1, N13.N1, N14.N1,  
24    N15.N1, N17.N1, N18.N1,  
25    N20.N1, N21.N1, N22.N1,  
26    N23.N1, N24.N1, N25.N1,  
27    N30.N1, N31.N1, N32.N1,  
28    N33.N1, N34.N1, N35.N1,  
29    N37.N1, N38.N1, N40.N1,  
30    N42.N1, N43.N1, N45.N1,  
31    N46.N1, N48.N1, N49.N1,  
32    N51.N1, N52.N1 /;  
33 *-----
```

34 ALIAS

35 (i,j);

36 *-----

37 PARAMETERS

Node N0 serves to take up slack within the network. By putting all slack demand on N0 and then linking it with all demand nodes and giving those a cost of zero, forces the program to find the shortest paths for all other demands first and then use the slack demand to balance the equations.

46

47 cost (i,j) arc length

48 / N0.N7 = 0, N0.N8 = 0, N0.N17 = 0,
49 N0.N18 = 0, N0.N27 = 0, N0.N28 = 0,
50 N0.N37 = 0, N0.N38 = 0, N0.N42 = 0,
51 N0.N43 = 0, N0.N53 = 0, N0.N54 = 0,
52 N0.N55 = 0, N0.N56 = 0, N0.N57 = 0,
53 N1.N7 = 7, N1.N8 = 7, N1.N17 = 7,
54 N1.N18 = 7, N1.N27 = 7, N1.N28 = 7,
55 N1.N37 = 7, N1.N38 = 7, N1.N42 = 7,
56 N1.N43 = 7, N1.N45 = 7, N1.N46 = 7,
57 N1.N48 = 7, N1.N49 = 7, N1.N53 = 16,
58 N1.N54 = 16, N1.N55 = 16, N1.N56 = 16,
59 N1.N57 = 16, N2.N1 = 5, N3.N1 = 16,
60 N5.N1 = 7, N6.N1 = 7, N7.N1 = 7,
61 N8.N1 = 7, N10.N1 = 7, N11.N1 = 7,
62 N12.N1 = 7, N13.N1 = 7, N14.N1 = 7,
63 N15.N1 = 7, N17.N1 = 7, N18.N1 = 7,
64 N20.N1 = 7, N21.N1 = 7, N22.N1 = 7,
65 N23.N1 = 7, N24.N1 = 7, N25.N1 = 7,
66 N30.N1 = 7, N31.N1 = 7, N32.N1 = 7,
67 N33.N1 = 7, N34.N1 = 7, N35.N1 = 7,
68 N37.N1 = 7, N38.N1 = 7, N40.N1 = 7,
69 N42.N1 = 7, N43.N1 = 7, N45.N1 = 7,
70 N46.N1 = 7, N48.N1 = 7, N49.N1 = 7,
71 N51.N1 = 7, N52.N1 = 7 /

72

73 b(i) vector of supplies and demands

74 / N7 = -2, N8 = -2, N17 = -1, N18 = -1, N27 = -1, N28 = -1,
75 N37 = -1, N38 = -1, N42 = -1, N43 = -1, N45 = -1, N46 = -1,
76 N48 = -1, N49 = -1, N53 = -3, N54 = -3, N55 = -3, N56 = -3,
77 N57 = -3, N11 = 1, N23 = 2, N24 = 3, N40 = 1, N51 = 2,
78 N5 = 2, N10 = 2, N12 = 1, N13 = 1, N34 = 3, N2 = 1,
79 N6 = 2, N20 = 1, N30 = 2, N31 = 1, N0 = 6/;

80 *-----

81 POSITIVE VARIABLE

82 X(i,j) amount of flow on each arc;

83 VARIABLE

84 TOTALTIME total time to satisfy all fire missions;

85 *-----

86 EQUATIONS

87 OBJ define objective function

88 FLOWBAL(i) flow conservation;

89 *-----

```

90 OBJ..      TOTALTIME =E= SUM(arc,cost(arc)*X(arc));
91 FLOWBAL(i)..  SUM(arc(i,j),X(i,j))-SUM(arc(j,i),X(j,i)) =E= b(i)
92 *-----
93 MODEL FIREMISSIONFLOW /ALL/;
94 FIREMISSIONFLOW.OPTFILE = 1;
95 SOLVE FIREMISSIONFLOW USING LP MINIMIZING TOTALTIME;
96 DISPLAY TOTALTIME.L,X,L;

```

COMPILATION TIME = 0.000 SECONDS 0.8 Mb WIN207-133

MODEL STATISTICS

```

BLOCKS OF EQUATIONS  2  SINGLE EQUATIONS  47
BLOCKS OF VARIABLES  2  SINGLE VARIABLES  72
NON ZERO ELEMENTS   199

```

GENERATION TIME = 0.000 SECONDS 1.6 Mb WIN207-133

EXECUTION TIME = 0.000 SECONDS 1.6 Mb WIN207-133

S O L V E S U M M A R Y

```

MODEL FIREMISSIONFLOW  OBJECTIVE TOTALTIME
TYPE LP                DIRECTION MINIMIZE
SOLVER XA              FROM LINE 95

```

```

**** SOLVER STATUS  1 NORMAL COMPLETION
**** MODEL STATUS  1 OPTIMAL
**** OBJECTIVE VALUE      429.0000

```

```

RESOURCE USAGE, LIMIT  0.060  100.000
ITERATION COUNT, LIMIT  12     1000

```

GAMS/XA Jun 14, 2002 WIN.XA.XA 20.7 011.024.040.VIS

Memory estimate (computed): 0.56MB

Copyright (c) 2000, 2001 by SUNSET SOFTWARE TECHNOLOGY.
1613 Chelsea Road, Suite 153
San Marino, California 91108 U.S.A.
All Rights Reserved Worldwide.
Telephone 626-441-1565 FAX 626-441-1567
EMAIL: jim@sunsetsoft.com
<http://www.sunsetsoft.com>

Licensed Solely To: GAMS DEVELOPMENT CORPORATION - 1208802
WASHINGTON, DC

```

STATISTICS - gams Tue Jan 13 09:33:30 2004
xa VERSION 13.68 NT DLL  USABLE MEMORY 0.5 MBYTE
ENV ID 1 SOLVE NUMBER 1
VARIABLES 72

```

0 LOWER, 0 FIXED, 0 UPPER, 1 FREE
 CONSTRAINTS 48
 0 GE, 47 EQ, 0 LE, 1 NULL/FREE, 0 RANGED.
 200 NON-ZEROS WORK 45,774
 MINIMIZATION.
 GAMS DEVELOPMENT CORPORATION - 1208802
 WASHINGTON, DC

**** REPORT SUMMARY : 0 NONOPT
 0 INFEASIBLE
 0 UNBOUNDED

96 VARIABLE TOTALTIME.L = 429.00 total time to satisfy
 all fire missions

---- 96 VARIABLE X.L amount of flow on each arc

	N1	N7	N8	N17	N18	N27
N1		2.00	2.00	1.00	1.00	1.00
N2	1.00					
N5	2.00					
N6	2.00					
N10	2.00					
N11	1.00					
N12	1.00					
N13	1.00					
N20	1.00					
N23	2.00					
N24	3.00					
N30	2.00					
N31	1.00					
N34	3.00					
N40	1.00					
N51	2.00					

96 VARIABLE X.L amount of flow on each arc

	N28	N37	N38	N42	N43	N45
N1	1.00	1.00	1.00	1.00	1.00	1.00

96 VARIABLE X.L amount of flow on each arc

	N46	N48	N49	N53	N54	N55
N1	1.00	1.00	1.00	3.00	3.00	3.00

96 VARIABLE X.L amount of flow on each arc

	N56	N57
N0	3.00	3.00

EXECUTION TIME = 0.000 SECONDS 1.6 Mb WIN207-133

USER: Michael R. Anderson G030318:1008CP-WIN
US Army TRAC, Joint Analysis Division DC904

**** FILE SUMMARY

INPUT C:\WINDOWS\GAMSDIR\FLAT_HI.GMS

OUTPUT C:\WINDOWS\GAMSDIR\FLAT_HI.LST

Annex D – Program and Output Data for Hierarchical Structure w/ Low Intensity

GAMS Rev 133 Windows NT/95/98 01/10/04 18:53:55 Page 1
General Algebraic Modeling System
Compilation

```
1 *-----
2 OPTIONS RESLIM = 100, ITERLIM = 1000
3     LIMCOL = 0, LIMROW = 0, DECIMALS = 2
4     SOLPRINT = OFF, LP = XA;
5 *-----
6 SET
7   i      nodes in the network /N0*N57/
8   arc(i,i) arcs in the network
9     /N0.N7, N0.N8, N0.N17,
10    N0.N18, N0.N27, N0.N28,
11    N0.N37, N0.N38, N0.N42,
12    N0.N43, N0.N53, N0.N54,
13    N0.N55, N0.N56, N0.N57,
14    N1.N4, N1.N9,
15    N1.N19, N1.N29, N1.N39,
16    N1.N53, N1.N54, N1.N55,
17    N1.N56, N1.N57, N2.N1,
18    N3.N1, N4.N1, N4.N7,
19    N4.N8, N5.N4, N6.N4,
20    N7.N4, N8.N4, N9.N1,
21    N9.N16, N10.N9, N11.N9,
22    N12.N9, N13.N9, N14.N9,
23    N15.N9, N16.N9, N16.N17,
24    N16.N18, N17.N16, N18.N16,
25    N19.N1, N19.N26, N20.N19,
26    N21.N19, N22.N19, N23.N19,
27    N24.N19, N25.N19, N26.N19,
28    N26.N27, N26.N28, N27.N26,
29    N28.N26, N29.N1, N29.N36,
30    N30.N29, N31.N29, N32.N29,
31    N33.N29, N34.N29, N35.N29,
32    N36.N29, N36.N37, N36.N38,
33    N37.N36, N38.N36, N39.N1,
```

```

34  N39.N41, N39.N44, N39.N47,
35  N40.N39, N41.N39, N41.N42,
36  N41.N43, N42.N41, N43.N41,
37  N44.N39, N44.N45, N44.N46,
38  N45.N44, N46.N44, N47.N39,
39  N47.N48, N47.N49, N48.N47,
40  N49.N47, N50.N1, N51.N50,
41  N52.N50 /;
42  *-----
43  ALIAS
44  (i,j);
45  *-----
46  PARAMETERS

```

Node N0 serves to take up slack within the network. By putting all slack demand on N0 and then linking it with all demand nodes and giving those arcs a cost of zero, forces the program to find the shortest paths for all other demands first and then use the slack demand to balance the equations.

```

55
56  cost (i,j)   arc length
57  / N0.N7 = 0,  N0.N8 = 0,  N0.N17 = 0,
58  N0.N18 = 0,  N0.N27 = 0,  N0.N28 = 0,
59  N0.N37 = 0,  N0.N38 = 0,  N0.N42 = 0,
60  N0.N43 = 0,  N0.N53 = 0,  N0.N54 = 0,
61  N0.N55 = 0,  N0.N56 = 0,  N0.N57 = 0,
62  N1.N4 = 5,  N1.N9 = 5,
63  N1.N19 = 5, N1.N29 = 5, N1.N39 = 5,
64  N1.N53 = 16, N1.N54 = 16, N1.N55 = 16,
65  N1.N56 = 16, N1.N57 = 16, N2.N1 = 16,
66  N3.N1 = 5,  N4.N1 = 5,  N4.N7 = 5,
67  N4.N8 = 5,  N5.N4 = 5,  N6.N4 = 5,
68  N7.N4 = 5,  N8.N4 = 5,  N9.N1 = 5,
69  N9.N16 = 5, N10.N9 = 5, N11.N9 = 5,
70  N12.N9 = 5, N13.N9 = 5, N14.N9 = 5,
71  N15.N9 = 5, N16.N9 = 5, N16.N17 = 5,
72  N16.N18 = 5, N17.N16 = 5, N18.N16 = 5,
73  N19.N1 = 5, N19.N26 = 5, N20.N19 = 5,
74  N21.N19 = 5, N22.N19 = 5, N23.N19 = 5,
75  N24.N19 = 5, N25.N19 = 5, N26.N19 = 5,
76  N26.N27 = 5, N26.N28 = 5, N27.N26 = 5,
77  N28.N26 = 5, N29.N1 = 5, N29.N36 = 5,
78  N30.N29 = 5, N31.N29 = 5, N32.N29 = 5,
79  N33.N29 = 5, N34.N29 = 5, N35.N29 = 5,
80  N36.N29 = 5, N36.N37 = 5, N36.N38 = 5,
81  N37.N36 = 5, N38.N36 = 5, N39.N1 = 5,
82  N39.N41 = 5, N39.N44 = 5, N39.N47 = 5,
83  N40.N39 = 5, N41.N39 = 5, N41.N42 = 5,
84  N41.N43 = 5, N42.N41 = 5, N43.N41 = 5,
85  N44.N39 = 5, N44.N45 = 5, N44.N46 = 5,
86  N45.N44 = 5, N46.N44 = 5, N47.N39 = 5,
87  N47.N48 = 5, N47.N49 = 5, N48.N47 = 5,
88  N49.N47 = 5, N50.N1 = 5, N51.N50 = 5,
89  N52.N50 = 5 /

```

```

90
91 b(i)      vector of supplies and demands
92 / N7 = -2, N8 = -2, N17 = -1, N18 = -1, N27 = -1, N28 = -1,
93   N37 = -1, N38 = -1, N42 = -1, N43 = -1, N45 = -1, N46 = -1,
94   N48 = -1, N49 = -1, N53 = -3, N54 = -3, N55 = -3, N56 = -3,
95   N57 = -3, N11 = 1, N23 = 2, N24 = 3, N40 = 1, N51 = 2,
96   N0 = 22/;
97 *-----
98 POSITIVE VARIABLE
99 X(i,j)    amount of flow on each arc;
100 VARIABLE
101 TOTALTIME  total time to satisfy all fire missions;
102 *-----
103 EQUATIONS
104 OBJ        define objective function
105 FLOWBAL(i) flow conservation;
106 *-----
107 OBJ..     TOTALTIME =E= SUM(arc,cost(arc)*X(arc));
108 FLOWBAL(i).. SUM(arc(i,j),X(i,j))-SUM(arc(j,i),X(j,i)) =E= b(i)
109 *-----
110 MODEL FIREMISSIONFLOW /ALL/;
111 FIREMISSIONFLOW.OPTFILE = 1;
112 SOLVE FIREMISSIONFLOW USING LP MINIMIZING TOTALTIME;
113 DISPLAY TOTALTIME.L,X,L;

```

COMPILATION TIME = 0.000 SECONDS 0.8 Mb WIN207-133

MODEL STATISTICS

BLOCKS OF EQUATIONS	2	SINGLE EQUATIONS	59
BLOCKS OF VARIABLES	2	SINGLE VARIABLES	97
NON ZERO ELEMENTS	274		

GENERATION TIME = 0.110 SECONDS 1.6 Mb WIN207-133

EXECUTION TIME = 0.160 SECONDS 1.6 Mb WIN207-133

S O L V E S U M M A R Y

```

MODEL FIREMISSIONFLOW OBJECTIVE TOTALTIME
TYPE LP                DIRECTION MINIMIZE
SOLVER XA              FROM LINE 112

```

```

**** SOLVER STATUS 1 NORMAL COMPLETION
**** MODEL STATUS 1 OPTIMAL
**** OBJECTIVE VALUE 175.0000

```

```

RESOURCE USAGE, LIMIT 0.270 100.000
ITERATION COUNT, LIMIT 19 1000

```

GAMS/XA Jun 14, 2002 WIN.XA.XA 20.7 011.024.040.VIS

Memory estimate (computed): 0.57MB
 Copyright (c) 2000, 2001 by SUNSET SOFTWARE TECHNOLOGY.
 1613 Chelsea Road, Suite 153
 San Marino, California 91108 U.S.A.
 All Rights Reserved Worldwide.
 Telephone 626-441-1565 FAX 626-441-1567
 EMAIL: jim@sunsetsoft.com
<http://www.sunsetsoft.com>

Licensed Solely To: GAMS DEVELOPMENT CORPORATION - 1208802
 WASHINGTON, DC

STATISTICS - gams Sat Jan 10 18:53:55 2004
 xa VERSION 13.68 NT DLL USABLE MEMORY 0.6 MBYTE
 ENV ID 1 SOLVE NUMBER 1
 VARIABLES 97
 0 LOWER, 0 FIXED, 0 UPPER, 1 FREE
 CONSTRAINTS 60
 0 GE, 59 EQ, 0 LE, 1 NULL/FREE, 0 RANGED.
 275 NON-ZEROS WORK 46,887
 MINIMIZATION.
 GAMS DEVELOPMENT CORPORATION - 1208802
 WASHINGTON, DC

**** REPORT SUMMARY : 0 NONOPT
 0 INFEASIBLE
 0 UNBOUNDED

113 VARIABLE TOTALTIME.L = 175.00 total time to satisfy
 all fire missions

---- 113 VARIABLE X.L amount of flow on each arc

	N1	N4	N7	N8	N9	N16
N0			2.00			
N1	2.00					
N4		2.00				
N9					1.00	
N11				1.00		
N19	3.00					
N50	2.00					

113 VARIABLE X.L amount of flow on each arc

	N17	N18	N19	N26	N27	N28
N0		1.00				
N16	1.00					
N19			2.00			
N23			2.00			
N24			3.00			

N26 1.00 1.00

113 VARIABLE X.L amount of flow on each arc

+	N37	N38	N39	N42	N43	N44
N0	1.00	1.00		1.00	1.00	
N1			3.00			
N39					2.00	
N40			1.00			

113 VARIABLE X.L amount of flow on each arc

+	N45	N46	N47	N48	N49	N50
N39			2.00			
N44	1.00	1.00				
N47			1.00	1.00		
N51					2.00	

113 VARIABLE X.L amount of flow on each arc

+	N53	N54	N55	N56	N57
N0	3.00	3.00	3.00	3.00	3.00

EXECUTION TIME = 0.060 SECONDS 1.6 Mb WIN207-133

USER: Michael R. Anderson G030318:1008CP-WIN
 US Army TRAC, Joint Analysis Division DC904

**** FILE SUMMARY

INPUT C:\WINDOWS\GAMSDIR\HIERARCHICAL_LOW.GMS
 OUTPUT C:\WINDOWS\GAMSDIR\HIERARCHICAL_LOW.LST

Annex E – Program and Output Data for Hierarchical Structure w/ Medium

Intensity

GAMS Rev 133 Windows NT/95/98 01/10/04 18:54:31 Page 1
 General Algebraic Modeling System
 Compilation

```

1 *-----
2 OPTIONS RESLIM = 100, ITERLIM = 1000
3   LIMCOL = 0, LIMROW = 0, DECIMALS = 2
4   SOLPRINT = OFF, LP = XA;
5 *-----
6 SET
7 i      nodes in the network /N0*N57/

```

```

8  arc(i,i)    arcs in the network
9  /N0.N7, N0.N8, N0.N17,
10 N0.N18, N0.N27, N0.N28,
11 N0.N37, N0.N38, N0.N42,
12 N0.N43, N0.N53, N0.N54,
13 N0.N55, N0.N56, N0.N57,
14 N1.N4, N1.N9,
15 N1.N19, N1.N29, N1.N39,
16 N1.N53, N1.N54, N1.N55,
17 N1.N56, N1.N57, N2.N1,
18 N3.N1, N4.N1, N4.N7,
19 N4.N8, N5.N4, N6.N4,
20 N7.N4, N8.N4, N9.N1,
21 N9.N16, N10.N9, N11.N9,
22 N12.N9, N13.N9, N14.N9,
23 N15.N9, N16.N9, N16.N17,
24 N16.N18, N17.N16, N18.N16,
25 N19.N1, N19.N26, N20.N19,
26 N21.N19, N22.N19, N23.N19,
27 N24.N19, N25.N19, N26.N19,
28 N26.N27, N26.N28, N27.N26,
29 N28.N26, N29.N1, N29.N36,
30 N30.N29, N31.N29, N32.N29,
31 N33.N29, N34.N29, N35.N29,
32 N36.N29, N36.N37, N36.N38,
33 N37.N36, N38.N36, N39.N1,
34 N39.N41, N39.N44, N39.N47,
35 N40.N39, N41.N39, N41.N42,
36 N41.N43, N42.N41, N43.N41,
37 N44.N39, N44.N45, N44.N46,
38 N45.N44, N46.N44, N47.N39,
39 N47.N48, N47.N49, N48.N47,
40 N49.N47, N50.N1, N51.N50,
41 N52.N50 /;
42 *-----
43 ALIAS
44 (i,j);
45 *-----
46 PARAMETERS

```

Node N0 serves to take up slack within the network. By putting all slack demand on N0 and then linking it with all demand nodes and giving those arcs a cost of zero, forces the program to find the shortest paths for all other demands first and then use the slack demand to balance the equations.

```

55
56 cost (i,j)    arc length
57 /N0.N7 = 0, N0.N8 = 0, N0.N17 = 0,
58 N0.N18 = 0, N0.N27 = 0, N0.N28 = 0,
59 N0.N37 = 0, N0.N38 = 0, N0.N42 = 0,
60 N0.N43 = 0, N0.N53 = 0, N0.N54 = 0,
61 N0.N55 = 0, N0.N56 = 0, N0.N57 = 0,
62 N1.N4 = 5, N1.N9 = 5,
63 N1.N19 = 5, N1.N29 = 5, N1.N39 = 5,

```

```

64  N1.N53 = 16, N1.N54 = 16, N1.N55 = 16,
65  N1.N56 = 16, N1.N57 = 16, N2.N1 = 16,
66  N3.N1 = 5,  N4.N1 = 5,  N4.N7 = 5,
67  N4.N8 = 5,  N5.N4 = 5,  N6.N4 = 5,
68  N7.N4 = 5,  N8.N4 = 5,  N9.N1 = 5,
69  N9.N16 = 5, N10.N9 = 5, N11.N9 = 5,
70  N12.N9 = 5, N13.N9 = 5, N14.N9 = 5,
71  N15.N9 = 5, N16.N9 = 5, N16.N17 = 5,
72  N16.N18 = 5, N17.N16 = 5, N18.N16 = 5,
73  N19.N1 = 5, N19.N26 = 5, N20.N19 = 5,
74  N21.N19 = 5, N22.N19 = 5, N23.N19 = 5,
75  N24.N19 = 5, N25.N19 = 5, N26.N19 = 5,
76  N26.N27 = 5, N26.N28 = 5, N27.N26 = 5,
77  N28.N26 = 5, N29.N1 = 5, N29.N36 = 5,
78  N30.N29 = 5, N31.N29 = 5, N32.N29 = 5,
79  N33.N29 = 5, N34.N29 = 5, N35.N29 = 5,
80  N36.N29 = 5, N36.N37 = 5, N36.N38 = 5,
81  N37.N36 = 5, N38.N36 = 5, N39.N1 = 5,
82  N39.N41 = 5, N39.N44 = 5, N39.N47 = 5,
83  N40.N39 = 5, N41.N39 = 5, N41.N42 = 5,
84  N41.N43 = 5, N42.N41 = 5, N43.N41 = 5,
85  N44.N39 = 5, N44.N45 = 5, N44.N46 = 5,
86  N45.N44 = 5, N46.N44 = 5, N47.N39 = 5,
87  N47.N48 = 5, N47.N49 = 5, N48.N47 = 5,
88  N49.N47 = 5, N50.N1 = 5, N51.N50 = 5,
89  N52.N50 = 5 /
90
91  b(i)      vector of supplies and demands
92  / N7 = -2, N8 = -2, N17 = -1, N18 = -1, N27 = -1, N28 = -1,
93  N37 = -1, N38 = -1, N42 = -1, N43 = -1, N45 = -1, N46 = -1,
94  N48 = -1, N49 = -1, N53 = -3, N54 = -3, N55 = -3, N56 = -3,
95  N57 = -3, N11 = 1, N23 = 2, N24 = 3, N40 = 1, N51 = 2,
96  N5 = 2, N10 = 2, N12 = 1, N13 = 1, N34 = 3, N0 = 13/;
97  *-----
98  POSITIVE VARIABLE
99  X(i,j)    amount of flow on each arc;
100 VARIABLE
101 TOTALTIME  total time to satisfy all fire missions;
102 *-----
103 EQUATIONS
104 OBJ        define objective function
105 FLOWBAL(i) flow conservation;
106 *-----
107 OBJ..      TOTALTIME =E= SUM(arc,cost(arc)*X(arc));
108 FLOWBAL(i).. SUM(arc(i,j),X(i,j))-SUM(arc(j,i),X(j,i)) =E= b(i)
109 *-----
110 MODEL FIREMISSIONFLOW /ALL/;
111 FIREMISSIONFLOW.OPTFILE = 1;
112 SOLVE FIREMISSIONFLOW USING LP MINIMIZING TOTALTIME;
113 DISPLAY TOTALTIME.L,X.L;

```

COMPILATION TIME = 0.000 SECONDS 0.8 Mb WIN207-133

MODEL STATISTICS

BLOCKS OF EQUATIONS 2 SINGLE EQUATIONS 59
BLOCKS OF VARIABLES 2 SINGLE VARIABLES 97
NON ZERO ELEMENTS 274

GENERATION TIME = 0.000 SECONDS 1.6 Mb WIN207-133

EXECUTION TIME = 0.000 SECONDS 1.6 Mb WIN207-133

S O L V E S U M M A R Y

MODEL FIREMISSIONFLOW OBJECTIVE TOTALTIME
TYPE LP DIRECTION MINIMIZE
SOLVER XA FROM LINE 112

**** SOLVER STATUS 1 NORMAL COMPLETION
**** MODEL STATUS 1 OPTIMAL
**** OBJECTIVE VALUE 342.0000

RESOURCE USAGE, LIMIT 0.000 100.000
ITERATION COUNT, LIMIT 24 1000

GAMS/XA Jun 14, 2002 WIN.XA.XA 20.7 011.024.040.VIS

Memory estimate (computed): 0.57MB
Copyright (c) 2000, 2001 by SUNSET SOFTWARE TECHNOLOGY.
1613 Chelsea Road, Suite 153
San Marino, California 91108 U.S.A.
All Rights Reserved Worldwide.
Telephone 626-441-1565 FAX 626-441-1567
EMAIL: jim@sunsetsoft.com
<http://www.sunsetsoft.com>

Licensed Solely To: GAMS DEVELOPMENT CORPORATION - 1208802
WASHINGTON, DC

STATISTICS - gams Sat Jan 10 18:54:31 2004
xa VERSION 13.68 NT DLL USABLE MEMORY 0.6 MBYTE
ENV ID 1 SOLVE NUMBER 1
VARIABLES 97
0 LOWER, 0 FIXED, 0 UPPER, 1 FREE
CONSTRAINTS 60
0 GE, 59 EQ, 0 LE, 1 NULL/FREE, 0 RANGED.
275 NON-ZEROS WORK 46,887
MINIMIZATION.
GAMS DEVELOPMENT CORPORATION - 1208802
WASHINGTON, DC

**** REPORT SUMMARY : 0 NONOPT
0 INFEASIBLE
0 UNBOUNDED

113 VARIABLE TOTALTIME.L = 342.00 total time to satisfy
all fire missions

---- 113 VARIABLE X.L amount of flow on each arc

	N1	N4	N7	N8	N9	N16
N1		2.00				
N4			2.00	2.00		
N5		2.00				
N9	3.00					2.00
N10				2.00		
N11				1.00		
N12				1.00		
N13				1.00		
N19	3.00					
N29	1.00					
N50	2.00					

113 VARIABLE X.L amount of flow on each arc

+	N17	N18	N19	N26	N27	N28
N16	1.00	1.00				
N19			2.00			
N23			2.00			
N24			3.00			
N26				1.00	1.00	

113 VARIABLE X.L amount of flow on each arc

+	N29	N36	N37	N38	N39	N41
N1				5.00		
N29		2.00				
N34	3.00					
N36			1.00	1.00		
N39					2.00	
N40				1.00		

113 VARIABLE X.L amount of flow on each arc

+	N42	N43	N44	N45	N46	N47
N39			2.00		2.00	
N41	1.00	1.00				
N44			1.00	1.00		

113 VARIABLE X.L amount of flow on each arc

+	N48	N49	N50	N53	N54	N55
N0			3.00	3.00	3.00	
N47	1.00	1.00				

```

113 VARIABLE X.L amount of flow on each arc
+   N48   N49   N50   N53   N54   N55
N51                2.00

```

```

113 VARIABLE X.L amount of flow on each arc
+   N56   N57
N0   1.00  3.00
N1   2.00

```

EXECUTION TIME = 0.000 SECONDS 1.6 Mb WIN207-133

USER: Michael R. Anderson G030318:1008CP-WIN
US Army TRAC, Joint Analysis Division DC904

**** FILE SUMMARY

INPUT C:\WINDOWS\GAMSDIR\HIERARCHICAL_MED.GMS
OUTPUT C:\WINDOWS\GAMSDIR\HIERARCHICAL_MED.LST

Annex F – Program and Output Data for Hierarchical Structure w/ High Intensity

GAMS Rev 133 Windows NT/95/98 01/13/04 09:34:57 Page 1
General Algebraic Modeling System
Compilation

```

1 *-----
2 OPTIONS RESLIM = 100, ITERLIM = 1000
3   LIMCOL = 0, LIMROW = 0, DECIMALS = 2
4   SOLPRINT = OFF, LP = XA;
5 *-----
6 SET
7   i      nodes in the network /N0*N57/
8   arc(i,i) arcs in the network
9   /N0.N7, N0.N8, N0.N17,
10  N0.N18, N0.N27, N0.N28,
11  N0.N37, N0.N38, N0.N42,
12  N0.N43, N0.N53, N0.N54,
13  N0.N55, N0.N56, N0.N57,
14  N1.N4, N1.N9,
15  N1.N19, N1.N29, N1.N39,
16  N1.N53, N1.N54, N1.N55,
17  N1.N56, N1.N57, N2.N1,
18  N3.N1, N4.N1, N4.N7,
19  N4.N8, N5.N4, N6.N4,
20  N7.N4, N8.N4, N9.N1,

```

```

21 N9.N16, N10.N9, N11.N9,
22 N12.N9, N13.N9, N14.N9,
23 N15.N9, N16.N9, N16.N17,
24 N16.N18, N17.N16, N18.N16,
25 N19.N1, N19.N26, N20.N19,
26 N21.N19, N22.N19, N23.N19,
27 N24.N19, N25.N19, N26.N19,
28 N26.N27, N26.N28, N27.N26,
29 N28.N26, N29.N1, N29.N36,
30 N30.N29, N31.N29, N32.N29,
31 N33.N29, N34.N29, N35.N29,
32 N36.N29, N36.N37, N36.N38,
33 N37.N36, N38.N36, N39.N1,
34 N39.N41, N39.N44, N39.N47,
35 N40.N39, N41.N39, N41.N42,
36 N41.N43, N42.N41, N43.N41,
37 N44.N39, N44.N45, N44.N46,
38 N45.N44, N46.N44, N47.N39,
39 N47.N48, N47.N49, N48.N47,
40 N49.N47, N50.N1, N51.N50,
41 N52.N50 /;
42 *-----
43 ALIAS
44 (i,j);
45 *-----
46 PARAMETERS

```

Node N0 serves to take up slack within the network. By putting all slack demand on N0 and then linking it with all demand nodes and giving those a rcs a cost of zero, forces the program to find the shortest paths for all other demands first and then use the slack demand to balance the equations.

```

55
56 cost (i,j)   arc length
57 / N0.N7 = 0,  N0.N8 = 0,  N0.N17 = 0,
58 N0.N18 = 0,  N0.N27 = 0,  N0.N28 = 0,
59 N0.N37 = 0,  N0.N38 = 0,  N0.N42 = 0,
60 N0.N43 = 0,  N0.N53 = 0,  N0.N54 = 0,
61 N0.N55 = 0,  N0.N56 = 0,  N0.N57 = 0,
62 N1.N4 = 5,  N1.N9 = 5,
63 N1.N19 = 5, N1.N29 = 5, N1.N39 = 5,
64 N1.N53 = 16, N1.N54 = 16, N1.N55 = 16,
65 N1.N56 = 16, N1.N57 = 16, N2.N1 = 16,
66 N3.N1 = 5,  N4.N1 = 5,  N4.N7 = 5,
67 N4.N8 = 5,  N5.N4 = 5,  N6.N4 = 5,
68 N7.N4 = 5,  N8.N4 = 5,  N9.N1 = 5,
69 N9.N16 = 5, N10.N9 = 5, N11.N9 = 5,
70 N12.N9 = 5, N13.N9 = 5, N14.N9 = 5,
71 N15.N9 = 5, N16.N9 = 5, N16.N17 = 5,
72 N16.N18 = 5, N17.N16 = 5, N18.N16 = 5,
73 N19.N1 = 5, N19.N26 = 5, N20.N19 = 5,
74 N21.N19 = 5, N22.N19 = 5, N23.N19 = 5,
75 N24.N19 = 5, N25.N19 = 5, N26.N19 = 5,
76 N26.N27 = 5, N26.N28 = 5, N27.N26 = 5,

```

```

77  N28.N26 = 5, N29.N1 = 5, N29.N36 = 5,
78  N30.N29 = 5, N31.N29 = 5, N32.N29 = 5,
79  N33.N29 = 5, N34.N29 = 5, N35.N29 = 5,
80  N36.N29 = 5, N36.N37 = 5, N36.N38 = 5,
81  N37.N36 = 5, N38.N36 = 5, N39.N1 = 5,
82  N39.N41 = 5, N39.N44 = 5, N39.N47 = 5,
83  N40.N39 = 5, N41.N39 = 5, N41.N42 = 5,
84  N41.N43 = 5, N42.N41 = 5, N43.N41 = 5,
85  N44.N39 = 5, N44.N45 = 5, N44.N46 = 5,
86  N45.N44 = 5, N46.N44 = 5, N47.N39 = 5,
87  N47.N48 = 5, N47.N49 = 5, N48.N47 = 5,
88  N49.N47 = 5, N50.N1 = 5, N51.N50 = 5,
89  N52.N50 = 5 /
90
91  b(i)      vector of supplies and demands
92  / N7 = -2, N8 = -2, N17 = -1, N18 = -1, N27 = -1, N28 = -1,
93  N37 = -1, N38 = -1, N42 = -1, N43 = -1, N45 = -1, N46 = -1,
94  N48 = -1, N49 = -1, N53 = -3, N54 = -3, N55 = -3, N56 = -3,
95  N57 = -3, N11 = 1, N23 = 2, N24 = 3, N40 = 1, N51 = 2,
96  N5 = 2, N10 = 2, N12 = 1, N13 = 1, N34 = 3, N2 = 1,
97  N6 = 2, N20 = 1, N30 = 2, N31 = 1, N0 = 6/;
98  *-----
99  POSITIVE VARIABLE
100 X(i,j)    amount of flow on each arc;
101 VARIABLE
102 TOTALTIME total time to satisfy all fire missions;
103 *-----
104 EQUATIONS
105 OBJ      define objective function
106 FLOWBAL(i) flow conservation;
107 *-----
108 OBJ..    TOTALTIME =E= SUM(arc,cost(arc)*X(arc));
109 FLOWBAL(i).. SUM(arc(i,j),X(i,j))-SUM(arc(j,i),X(j,i)) =E= b(i)
110 *-----
111 MODEL FIREMISSIONFLOW /ALL/;
112 FIREMISSIONFLOW.OPTFILE = 1;
113 SOLVE FIREMISSIONFLOW USING LP MINIMIZING TOTALTIME;
114 DISPLAY TOTALTIME.L,X.L;

```

COMPILATION TIME = 0.050 SECONDS 0.8 Mb WIN207-133

MODEL STATISTICS

BLOCKS OF EQUATIONS	2	SINGLE EQUATIONS	59
BLOCKS OF VARIABLES	2	SINGLE VARIABLES	97
NON ZERO ELEMENTS	274		

GENERATION TIME = 0.000 SECONDS 1.6 Mb WIN207-133

EXECUTION TIME = 0.000 SECONDS 1.6 Mb WIN207-133

SOLVE SUMMARY

MODEL FIREMISSIONFLOW OBJECTIVE TOTALTIME
TYPE LP DIRECTION MINIMIZE
SOLVER XA FROM LINE 113

**** SOLVER STATUS 1 NORMAL COMPLETION
**** MODEL STATUS 1 OPTIMAL
**** OBJECTIVE VALUE 510.0000

RESOURCE USAGE, LIMIT 0.050 100.000
ITERATION COUNT, LIMIT 21 1000

GAMS/XA Jun 14, 2002 WIN.XA.XA 20.7 011.024.040.VIS

Memory estimate (computed): 0.57MB
Copyright (c) 2000, 2001 by SUNSET SOFTWARE TECHNOLOGY.
1613 Chelsea Road, Suite 153
San Marino, California 91108 U.S.A.
All Rights Reserved Worldwide.
Telephone 626-441-1565 FAX 626-441-1567
EMAIL: jim@sunsetsoft.com
<http://www.sunsetsoft.com>

Licensed Solely To: GAMS DEVELOPMENT CORPORATION - 1208802
WASHINGTON, DC

STATISTICS - gams Tue Jan 13 09:34:57 2004
xa VERSION 13.68 NT DLL USABLE MEMORY 0.6 MBYTE
ENV ID 1 SOLVE NUMBER 1
VARIABLES 97
0 LOWER, 0 FIXED, 0 UPPER, 1 FREE
CONSTRAINTS 60
0 GE, 59 EQ, 0 LE, 1 NULL/FREE, 0 RANGED.
275 NON-ZEROS WORK 46,887
MINIMIZATION.
GAMS DEVELOPMENT CORPORATION - 1208802
WASHINGTON, DC

**** REPORT SUMMARY : 0 NONOPT
0 INFEASIBLE
0 UNBOUNDED

114 VARIABLE TOTALTIME.L = 510.00 total time to satisfy
all fire missions

---- 114 VARIABLE X.L amount of flow on each arc

	N1	N4	N7	N8	N9	N16
N2	1.00					
N4			2.00	2.00		
N5		2.00				

N6	2.00				
N9	3.00			2.00	
N10				2.00	
N11				1.00	
N12				1.00	
N13				1.00	
N19	4.00				
N29	4.00				
N50	2.00				

114 VARIABLE X.L amount of flow on each arc

+	N17	N18	N19	N26	N27	N28
N16	1.00	1.00				
N19			2.00			
N20			1.00			
N23			2.00			
N24			3.00			
N26				1.00	1.00	

114 VARIABLE X.L amount of flow on each arc

+	N29	N36	N37	N38	N39	N41
N1				5.00		
N29		2.00				
N30	2.00					
N31	1.00					
N34	3.00					
N36			1.00	1.00		
N39					2.00	
N40				1.00		

114 VARIABLE X.L amount of flow on each arc

+	N42	N43	N44	N45	N46	N47
N39			2.00		2.00	
N41	1.00	1.00				
N44			1.00	1.00		

114 VARIABLE X.L amount of flow on each arc

+	N48	N49	N50	N53	N54	N55
N0				3.00		
N1			3.00		3.00	
N47	1.00	1.00				
N51			2.00			

114 VARIABLE X.L amount of flow on each arc

+	N56	N57
N0	3.00	

N1 3.00

EXECUTION TIME = 0.000 SECONDS 1.6 Mb WIN207-133

USER: Michael R. Anderson G030318:1008CP-WIN
US Army TRAC, Joint Analysis Division DC904

**** FILE SUMMARY

INPUT C:\WINDOWS\GAMSDIR\HIERARCHICAL_HI.GMS
OUTPUT C:\WINDOWS\GAMSDIR\HIERARCHICAL_HIL.LST

Annex G – Program and Output Data for Composite Structure w/ Low Intensity

GAMS Rev 133 Windows NT/95/98 01/13/04 08:46:12 Page 1
General Algebraic Modeling System
Compilation

```
1 *-----  
2 OPTIONS RESLIM = 100, ITERLIM = 1000  
3     LIMCOL = 0, LIMROW = 0, DECIMALS = 2  
4     SOLPRINT = OFF, LP = XA;  
5 *-----  
6 SET  
7 i      nodes in the network /N0*N57/  
8 arc(i,i)  arcs in the network  
9   /N0.N7, N0.N8, N0.N17,  
10  N0.N18, N0.N27, N0.N28,  
11  N0.N37, N0.N38, N0.N42,  
12  N0.N43, N0.N53, N0.N54,  
13  N0.N55, N0.N56, N0.N57,  
14  N1.N4, N1.N9, N1.N19,  
15  N1.N29, N1.N39, N1.N53,  
16  N1.N54, N1.N55, N1.N56,  
17  N1.N57, N2.N1, N3.N1,  
18  N4.N1, N4.N7, N4.N8,  
19  N5.N4, N6.N4, N7.N4,  
20  N8.N4, N9.N1, N9.N17,  
21  N9.N18, N10.N9, N11.N9,  
22  N12.N9, N13.N9, N14.N9,  
23  N15.N9, N17.N9, N18.N9,  
24  N19.N1, N19.N27, N19.N28,  
25  N20.N19, N21.N19, N22.N19,  
26  N23.N19, N24.N19, N25.N19,  
27  N27.N19, N28.N19, N29.N1,  
28  N29.N37, N29.N38, N30.N29,  
29  N31.N29, N32.N29, N33.N29,  
30  N34.N29, N35.N29, N37.N29,  
31  N38.N29, N39.N1, N39.N42,  
32  N39.N43, N39.N45, N39.N46,
```

```

33   N39.N48, N39.N49, N40.N39,
34   N42.N39, N43.N39, N45.N39,
35   N46.N39, N48.N39, N49.N39,
36   N51.N1, N52.N1 /;
37 *-----
38 ALIAS
39 (i,j);
40 *-----
41 PARAMETERS

```

Node N0 serves to take up slack within the network. By putting all slack demand on N0 and then linking it with all demand nodes and giving those arcs a cost of zero, forces the program to find the shortest paths for all other demands first and then use the slack demand to balance the equations.

```

50
51 cost (i,j)   arc length
52 / N0.N7 = 0,  N0.N8 = 0,  N0.N17 = 0,
53   N0.N18 = 0,  N0.N27 = 0,  N0.N28 = 0,
54   N0.N37 = 0,  N0.N38 = 0,  N0.N42 = 0,
55   N0.N43 = 0,  N0.N53 = 0,  N0.N54 = 0,
56   N0.N55 = 0,  N0.N56 = 0,  N0.N57 = 0,
57   N1.N4 = 5,  N1.N9 = 5,  N1.N19 = 5,
58   N1.N29 = 5,  N1.N39 = 5,  N1.N53 = 16,
59   N1.N54 = 16,  N1.N55 = 16,  N1.N56 = 16,
60   N1.N57 = 16,  N2.N1 = 5,  N3.N1 = 5,
61   N4.N1 = 5,  N4.N7 = 5,  N4.N8 = 5,
62   N5.N4 = 5,  N6.N4 = 5,  N7.N4 = 5,
63   N8.N4 = 5,  N9.N1 = 5,  N9.N17 = 7,
64   N9.N18 = 7,  N10.N9 = 5,  N11.N9 = 5,
65   N12.N9 = 5,  N13.N9 = 5,  N14.N9 = 5,
66   N15.N9 = 5,  N17.N9 = 7,  N18.N9 = 7,
67   N19.N1 = 5,  N19.N27 = 7,  N19.N28 = 7,
68   N20.N19 = 5,  N21.N19 = 5,  N22.N19 = 5,
69   N23.N19 = 5,  N24.N19 = 5,  N25.N19 = 5,
70   N27.N19 = 7,  N28.N19 = 7,  N29.N1 = 5,
71   N29.N37 = 7,  N29.N38 = 7,  N30.N29 = 5,
72   N31.N29 = 5,  N32.N29 = 5,  N33.N29 = 5,
73   N34.N29 = 5,  N35.N29 = 5,  N37.N29 = 7,
74   N38.N29 = 7,  N39.N1 = 5,  N39.N42 = 7,
75   N39.N43 = 7,  N39.N45 = 7,  N39.N46 = 7,
76   N39.N48 = 7,  N39.N49 = 7,  N40.N39 = 5,
77   N42.N39 = 7,  N43.N39 = 7,  N45.N39 = 7,
78   N46.N39 = 7,  N48.N39 = 7,  N49.N39 = 7,
79   N51.N1 = 5,  N52.N1 = 5 /
80
81 b(i)         vector of supplies and demands
82 / N7 = -2,  N8 = -2,  N17 = -1,  N18 = -1,  N27 = -1,  N28 = -1,
83   N37 = -1,  N38 = -1,  N42 = -1,  N43 = -1,  N45 = -1,  N46 = -1,
84   N48 = -1,  N49 = -1,  N53 = -3,  N54 = -3,  N55 = -3,  N56 = -3,
85   N57 = -3,  N11 = 1,  N23 = 2,  N24 = 3,  N40 = 1,  N51 = 2,
86   N0 = 22/;
87 *-----
88 POSITIVE VARIABLE

```

```

89 X(i,j)    amount of flow on each arc;
90 VARIABLE
91 TOTALTIME    total time to satisfy all fire missions;
92 *-----
93 EQUATIONS
94 OBJ          define objective function
95 FLOWBAL(i)   flow conservation;
96 *-----
97 OBJ..        TOTALTIME =E= SUM(arc,cost(arc)*X(arc));
98 FLOWBAL(i).. SUM(arc(i,j),X(i,j))-SUM(arc(j,i),X(j,i)) =E= b(i)
99 *-----
100 MODEL FIREMISSIONFLOW /ALL/;
101 FIREMISSIONFLOW.OPTFILE = 1;
102 SOLVE FIREMISSIONFLOW USING LP MINIMIZING TOTALTIME;

103 DISPLAY TOTALTIME.L,X.L;

```

COMPILATION TIME = 0.050 SECONDS 0.8 Mb WIN207-133

MODEL STATISTICS

BLOCKS OF EQUATIONS	2	SINGLE EQUATIONS	52
BLOCKS OF VARIABLES	2	SINGLE VARIABLES	84
NON ZERO ELEMENTS	235		

GENERATION TIME = 0.110 SECONDS 1.6 Mb WIN207-133

EXECUTION TIME = 0.110 SECONDS 1.6 Mb WIN207-133

S O L V E S U M M A R Y

```

MODEL FIREMISSIONFLOW OBJECTIVE TOTALTIME
TYPE LP                DIRECTION MINIMIZE
SOLVER XA              FROM LINE 102

```

```

**** SOLVER STATUS 1 NORMAL COMPLETION
**** MODEL STATUS 1 OPTIMAL
**** OBJECTIVE VALUE      144.0000

```

```

RESOURCE USAGE, LIMIT 0.280 100.000
ITERATION COUNT, LIMIT 9 1000

```

GAMS/XA Jun 14, 2002 WIN.XA.XA 20.7 011.024.040.VIS

Memory estimate (computed): 0.56MB
 Copyright (c) 2000, 2001 by SUNSET SOFTWARE TECHNOLOGY.
 1613 Chelsea Road, Suite 153
 San Marino, California 91108 U.S.A.
 All Rights Reserved Worldwide.
 Telephone 626-441-1565 FAX 626-441-1567
 EMAIL: jim@sunsetsoft.com
<http://www.sunsetsoft.com>

Licensed Solely To: GAMS DEVELOPMENT CORPORATION - 1208802
 WASHINGTON, DC

STATISTICS - gams Tue Jan 13 08:46:13 2004
 xa VERSION 13.68 NT DLL USABLE MEMORY 0.5 MBYTE
 ENV ID 1 SOLVE NUMBER 1
 VARIABLES 84
 0 LOWER, 0 FIXED, 0 UPPER, 1 FREE
 CONSTRAINTS 53
 0 GE, 52 EQ, 0 LE, 1 NULL/FREE, 0 RANGED.
 236 NON-ZEROS WORK 46,262
 MINIMIZATION.
 GAMS DEVELOPMENT CORPORATION - 1208802
 WASHINGTON, DC

**** REPORT SUMMARY : 0 NONOPT
 0 INFEASIBLE
 0 UNBOUNDED

103 VARIABLE TOTALTIME.L = 144.00 total time to satisfy
 all fire missions

---- 103 VARIABLE X.L amount of flow on each arc

	N1	N4	N7	N8	N9	N17
N0			2.00		1.00	
N1	2.00					
N4		2.00				
N11				1.00		
N19	3.00					
N51	2.00					

103 VARIABLE X.L amount of flow on each arc

+	N18	N19	N27	N28	N37	N38
N0				1.00	1.00	
N9	1.00					
N19		1.00	1.00			
N23		2.00				
N24		3.00				

103 VARIABLE X.L amount of flow on each arc

+	N39	N42	N43	N45	N46	N48
N0		1.00	1.00			
N1	3.00					
N39			1.00	1.00	1.00	
N40	1.00					

103 VARIABLE X.L amount of flow on each arc

	N49	N53	N54	N55	N56	N57
N0		3.00	3.00	3.00	3.00	3.00
N39	1.00					

EXECUTION TIME = 0.000 SECONDS 1.6 Mb WIN207-133

USER: Michael R. Anderson G030318:1008CP-WIN
US Army TRAC, Joint Analysis Division DC904

**** FILE SUMMARY

INPUT C:\WINDOWS\GAMSDIR\COMPOSITE_LOW.GMS
OUTPUT C:\WINDOWS\GAMSDIR\COMPOSITE_LOW.LST

Annex H – Program and Output Data for Composite Structure w/ Medium Intensity

GAMS Rev 133 Windows NT/95/98 01/13/04 08:48:19 Page 1
General Algebraic Modeling System
Compilation

```
1 *-----
2 OPTIONS RESLIM = 100, ITERLIM = 1000
3   LIMCOL = 0, LIMROW = 0, DECIMALS = 2
4   SOLPRINT = OFF, LP = XA;
5 *-----
6 SET
7   i      nodes in the network /N0*N57/
8   arc(i,i) arcs in the network
9   /N0.N7, N0.N8, N0.N17,
10  N0.N18, N0.N27, N0.N28,
11  N0.N37, N0.N38, N0.N42,
12  N0.N43, N0.N53, N0.N54,
13  N0.N55, N0.N56, N0.N57,
14  N1.N4, N1.N9, N1.N19,
15  N1.N29, N1.N39, N1.N53,
16  N1.N54, N1.N55, N1.N56,
17  N1.N57, N2.N1, N3.N1,
18  N4.N1, N4.N7, N4.N8,
19  N5.N4, N6.N4, N7.N4,
20  N8.N4, N9.N1, N9.N17,
21  N9.N18, N10.N9, N11.N9,
22  N12.N9, N13.N9, N14.N9,
23  N15.N9, N17.N9, N18.N9,
24  N19.N1, N19.N27, N19.N28,
25  N20.N19, N21.N19, N22.N19,
26  N23.N19, N24.N19, N25.N19,
```

```

27 N27.N19, N28.N19, N29.N1,
28 N29.N37, N29.N38, N30.N29,
29 N31.N29, N32.N29, N33.N29,
30 N34.N29, N35.N29, N37.N29,
31 N38.N29, N39.N1, N39.N42,
32 N39.N43, N39.N45, N39.N46,
33 N39.N48, N39.N49, N40.N39,
34 N42.N39, N43.N39, N45.N39,
35 N46.N39, N48.N39, N49.N39,
36 N51.N1, N52.N1 /;

```

```

37 *-----
38 ALIAS
39 (i,j);
40 *-----

```

41 PARAMETERS

Node N0 serves to take up slack within the network. By putting all slack demand on N0 and then linking it with all demand nodes and giving those a rcs a cost of zero, forces the program to find the shortest paths for all other demands first and then use the slack demand to balance the equations.

```

50
51 cost (i,j)   arc length
52 / N0.N7 = 0,  N0.N8 = 0,  N0.N17 = 0,
53  N0.N18 = 0,  N0.N27 = 0,  N0.N28 = 0,
54  N0.N37 = 0,  N0.N38 = 0,  N0.N42 = 0,
55  N0.N43 = 0,  N0.N53 = 0,  N0.N54 = 0,
56  N0.N55 = 0,  N0.N56 = 0,  N0.N57 = 0,
57  N1.N4 = 5,  N1.N9 = 5,  N1.N19 = 5,
58  N1.N29 = 5,  N1.N39 = 5,  N1.N53 = 16,
59  N1.N54 = 16,  N1.N55 = 16,  N1.N56 = 16,
60  N1.N57 = 16,  N2.N1 = 5,  N3.N1 = 5,
61  N4.N1 = 5,  N4.N7 = 5,  N4.N8 = 5,
62  N5.N4 = 5,  N6.N4 = 5,  N7.N4 = 5,
63  N8.N4 = 5,  N9.N1 = 5,  N9.N17 = 7,
64  N9.N18 = 7,  N10.N9 = 5,  N11.N9 = 5,
65  N12.N9 = 5,  N13.N9 = 5,  N14.N9 = 5,
66  N15.N9 = 5,  N17.N9 = 7,  N18.N9 = 7,
67  N19.N1 = 5,  N19.N27 = 7,  N19.N28 = 7,
68  N20.N19 = 5,  N21.N19 = 5,  N22.N19 = 5,
69  N23.N19 = 5,  N24.N19 = 5,  N25.N19 = 5,
70  N27.N19 = 7,  N28.N19 = 7,  N29.N1 = 5,
71  N29.N37 = 7,  N29.N38 = 7,  N30.N29 = 5,
72  N31.N29 = 5,  N32.N29 = 5,  N33.N29 = 5,
73  N34.N29 = 5,  N35.N29 = 5,  N37.N29 = 7,
74  N38.N29 = 7,  N39.N1 = 5,  N39.N42 = 7,
75  N39.N43 = 7,  N39.N45 = 7,  N39.N46 = 7,
76  N39.N48 = 7,  N39.N49 = 7,  N40.N39 = 5,
77  N42.N39 = 7,  N43.N39 = 7,  N45.N39 = 7,
78  N46.N39 = 7,  N48.N39 = 7,  N49.N39 = 7,
79  N51.N1 = 5,  N52.N1 = 5 /
80
81 b(i)         vector of supplies and demands
82 / N7 = -2,  N8 = -2,  N17 = -1,  N18 = -1,  N27 = -1,  N28 = -1,

```

```

83   N37 = -1, N38 = -1, N42 = -1, N43 = -1, N45 = -1, N46 = -1,
84   N48 = -1, N49 = -1, N53 = -3, N54 = -3, N55 = -3, N56 = -3,
85   N57 = -3, N11 = 1, N23 = 2, N24 = 3, N40 = 1, N51 = 2,
86   N5 = 2, N10 = 2, N12 = 1, N13 = 1, N34 = 3, N0 = 13/;
87 *-----
88 POSITIVE VARIABLE
89 X(i,j) amount of flow on each arc;
90 VARIABLE
91 TOTALTIME total time to satisfy all fire missions;
92 *-----
93 EQUATIONS
94 OBJ define objective function
95 FLOWBAL(i) flow conservation;
96 *-----
97 OBJ.. TOTALTIME =E= SUM(arc,cost(arc)*X(arc));
98 FLOWBAL(i).. SUM(arc(i,j),X(i,j))-SUM(arc(j,i),X(j,i)) =E= b(i)
99 *-----
100 MODEL FIREMISSIONFLOW /ALL/;
101 FIREMISSIONFLOW.OPTFILE = 1;
102 SOLVE FIREMISSIONFLOW USING LP MINIMIZING TOTALTIME;
103 DISPLAY TOTALTIME,L,X,L;

```

COMPILATION TIME = 0.000 SECONDS 0.8 Mb WIN207-133

MODEL STATISTICS

```

BLOCKS OF EQUATIONS 2 SINGLE EQUATIONS 52
BLOCKS OF VARIABLES 2 SINGLE VARIABLES 84
NON ZERO ELEMENTS 235

```

GENERATION TIME = 0.000 SECONDS 1.6 Mb WIN207-133

EXECUTION TIME = 0.000 SECONDS 1.6 Mb WIN207-133

SOLVE SUMMARY

```

MODEL FIREMISSIONFLOW OBJECTIVE TOTALTIME
TYPE LP DIRECTION MINIMIZE
SOLVER XA FROM LINE 102

```

```

**** SOLVER STATUS 1 NORMAL COMPLETION
**** MODEL STATUS 1 OPTIMAL
**** OBJECTIVE VALUE 296.0000

```

```

RESOURCE USAGE, LIMIT 0.000 100.000
ITERATION COUNT, LIMIT 15 1000

```

GAMS/XA Jun 14, 2002 WIN.XA.XA 20.7 011.024.040.VIS

Memory estimate (computed): 0.56MB

Copyright (c) 2000, 2001 by SUNSET SOFTWARE TECHNOLOGY.
1613 Chelsea Road, Suite 153

San Marino, California 91108 U.S.A.
 All Rights Reserved Worldwide.
 Telephone 626-441-1565 FAX 626-441-1567
 EMAIL: jim@sunsetsoft.com
 http://www.sunsetsoft.com

Licensed Solely To: GAMS DEVELOPMENT CORPORATION - 1208802
 WASHINGTON, DC

STATISTICS - gams Tue Jan 13 08:48:19 2004
 xa VERSION 13.68 NT DLL USABLE MEMORY 0.5 MBYTE
 ENV ID 1 SOLVE NUMBER 1
 VARIABLES 84
 0 LOWER, 0 FIXED, 0 UPPER, 1 FREE
 CONSTRAINTS 53
 0 GE, 52 EQ, 0 LE, 1 NULL/FREE, 0 RANGED.
 236 NON-ZEROS WORK 46,262
 MINIMIZATION.
 GAMS DEVELOPMENT CORPORATION - 1208802
 WASHINGTON, DC

**** REPORT SUMMARY : 0 NONOPT
 0 INFEASIBLE
 0 UNBOUNDED

103 VARIABLE TOTALTIME.L = 296.00 total time to satisfy
 all fire missions

---- 103 VARIABLE X.L amount of flow on each arc

	N1	N4	N7	N8	N9	N17
N1		2.00				
N4			2.00	2.00		
N5		2.00				
N9	3.00				1.00	
N10				2.00		
N11				1.00		
N12				1.00		
N13				1.00		
N19	3.00					
N29	1.00					
N51	2.00					

103 VARIABLE X.L amount of flow on each arc

	N18	N19	N27	N28	N29	N37
N9	1.00					
N19			1.00	1.00		
N23		2.00				
N24		3.00				

N29 1.00
 N34 3.00

103 VARIABLE X.L amount of flow on each arc

+ N38 N39 N42 N43 N45 N46
 N1 5.00
 N29 1.00
 N39 1.00 1.00 1.00 1.00
 N40 1.00

103 VARIABLE X.L amount of flow on each arc

+ N48 N49 N53 N54 N55 N56
 N0 1.00 3.00 3.00 3.00
 N1 2.00
 N39 1.00 1.00

103 VARIABLE X.L amount of flow on each arc

+ N57
 N0 3.00

EXECUTION TIME = 0.000 SECONDS 1.6 Mb WIN207-133

USER: Michael R. Anderson G030318:1008CP-WIN
 US Army TRAC, Joint Analysis Division DC904

**** FILE SUMMARY

INPUT C:\WINDOWS\GAMSDIR\COMPOSITE_MED.GMS
 OUTPUT C:\WINDOWS\GAMSDIR\COMPOSITE_MED.LST

Annex I – Program and Output Data for Composite Structure w/ High Intensity

GAMS Rev 133 Windows NT/95/98 01/13/04 09:34:21 Page 1
 General Algebraic Modeling System
 Compilation

```

1 *-----
2 OPTIONS RESLIM = 100, ITERLIM = 1000
3   LIMCOL = 0, LIMROW = 0, DECIMALS = 2
4   SOLPRINT = OFF, LP = XA;
5 *-----
6 SET
7   i      nodes in the network /N0*N57/
8   arc(i,i) arcs in the network
9   /N0.N7, N0.N8, N0.N17,
```

```

10  N0.N18, N0.N27, N0.N28,
11  N0.N37, N0.N38, N0.N42,
12  N0.N43, N0.N53, N0.N54,
13  N0.N55, N0.N56, N0.N57,
14  N1.N4, N1.N9, N1.N19,
15  N1.N29, N1.N39, N1.N53,
16  N1.N54, N1.N55, N1.N56,
17  N1.N57, N2.N1, N3.N1,
18  N4.N1, N4.N7, N4.N8,
19  N5.N4, N6.N4, N7.N4,
20  N8.N4, N9.N1, N9.N17,
21  N9.N18, N10.N9, N11.N9,
22  N12.N9, N13.N9, N14.N9,
23  N15.N9, N17.N9, N18.N9,
24  N19.N1, N19.N27, N19.N28,
25  N20.N19, N21.N19, N22.N19,
26  N23.N19, N24.N19, N25.N19,
27  N27.N19, N28.N19, N29.N1,
28  N29.N37, N29.N38, N30.N29,
29  N31.N29, N32.N29, N33.N29,
30  N34.N29, N35.N29, N37.N29,
31  N38.N29, N39.N1, N39.N42,
32  N39.N43, N39.N45, N39.N46,
33  N39.N48, N39.N49, N40.N39,
34  N42.N39, N43.N39, N45.N39,
35  N46.N39, N48.N39, N49.N39,
36  N51.N1, N52.N1 /;
37  *-----
38  ALIAS
39  (i,j);
40  *-----
41  PARAMETERS

```

Node N0 serves to take up slack within the network. By putting all slack demand on N0 and then linking it with all demand nodes and giving those a cost of zero, forces the program to find the shortest paths for all other demands first and then use the slack demand to balance the equations.

```

50
51  cost (i,j)  arc length
52  /N0.N7 = 0,  N0.N8 = 0,  N0.N17 = 0,
53  N0.N18 = 0,  N0.N27 = 0,  N0.N28 = 0,
54  N0.N37 = 0,  N0.N38 = 0,  N0.N42 = 0,
55  N0.N43 = 0,  N0.N53 = 0,  N0.N54 = 0,
56  N0.N55 = 0,  N0.N56 = 0,  N0.N57 = 0,
57  N1.N4 = 5,  N1.N9 = 5,  N1.N19 = 5,
58  N1.N29 = 5,  N1.N39 = 5,  N1.N53 = 16,
59  N1.N54 = 16,  N1.N55 = 16,  N1.N56 = 16,
60  N1.N57 = 16,  N2.N1 = 5,  N3.N1 = 5,
61  N4.N1 = 5,  N4.N7 = 5,  N4.N8 = 5,
62  N5.N4 = 5,  N6.N4 = 5,  N7.N4 = 5,
63  N8.N4 = 5,  N9.N1 = 5,  N9.N17 = 7,
64  N9.N18 = 7,  N10.N9 = 5,  N11.N9 = 5,
65  N12.N9 = 5,  N13.N9 = 5,  N14.N9 = 5,

```

```

66  N15.N9 = 5, N17.N9 = 7, N18.N9 = 7,
67  N19.N1 = 5, N19.N27 = 7, N19.N28 = 7,
68  N20.N19 = 5, N21.N19 = 5, N22.N19 = 5,
69  N23.N19 = 5, N24.N19 = 5, N25.N19 = 5,
70  N27.N19 = 7, N28.N19 = 7, N29.N1 = 5,
71  N29.N37 = 7, N29.N38 = 7, N30.N29 = 5,
72  N31.N29 = 5, N32.N29 = 5, N33.N29 = 5,
73  N34.N29 = 5, N35.N29 = 5, N37.N29 = 7,
74  N38.N29 = 7, N39.N1 = 5, N39.N42 = 7,
75  N39.N43 = 7, N39.N45 = 7, N39.N46 = 7,
76  N39.N48 = 7, N39.N49 = 7, N40.N39 = 5,
77  N42.N39 = 7, N43.N39 = 7, N45.N39 = 7,
78  N46.N39 = 7, N48.N39 = 7, N49.N39 = 7,
79  N51.N1 = 5, N52.N1 = 5 /
80
81  b(i)      vector of supplies and demands
82  / N7 = -2, N8 = -2, N17 = -1, N18 = -1, N27 = -1, N28 = -1,
83  N37 = -1, N38 = -1, N42 = -1, N43 = -1, N45 = -1, N46 = -1,
84  N48 = -1, N49 = -1, N53 = -3, N54 = -3, N55 = -3, N56 = -3,
85  N57 = -3, N11 = 1, N23 = 2, N24 = 3, N40 = 1, N51 = 2,
86  N5 = 2, N10 = 2, N12 = 1, N13 = 1, N34 = 3, N2 = 1,
87  N6 = 2, N20 = 1, N30 = 2, N31 = 1, N0 = 6/;
88  *-----
89  POSITIVE VARIABLE
90  X(i,j)      amount of flow on each arc;
91  VARIABLE
92  TOTALTIME  total time to satisfy all fire missions;
93  *-----
94  EQUATIONS
95  OBJ        define objective function
96  FLOWBAL(i) flow conservation;
97  *-----
98  OBJ..      TOTALTIME =E= SUM(arc,cost(arc)*X(arc));
99  FLOWBAL(i).. SUM(arc(i,j),X(i,j))-SUM(arc(j,i),X(j,i)) =E= b(i)
100 *-----
101 MODEL FIREMISSIONFLOW /ALL/;
102 FIREMISSIONFLOW.OPTFILE = 1;
103 SOLVE FIREMISSIONFLOW USING LP MINIMIZING TOTALTIME;
104 DISPLAY TOTALTIME.L,X.L;

```

COMPILATION TIME = 0.000 SECONDS 0.8 Mb WIN207-133

MODEL STATISTICS

BLOCKS OF EQUATIONS	2	SINGLE EQUATIONS	52
BLOCKS OF VARIABLES	2	SINGLE VARIABLES	84
NON ZERO ELEMENTS	235		

GENERATION TIME = 0.000 SECONDS 1.6 Mb WIN207-133

EXECUTION TIME = 0.000 SECONDS 1.6 Mb WIN207-133

SOLVE SUMMARY

MODEL FIREMISSIONFLOW OBJECTIVE TOTALTIME
TYPE LP DIRECTION MINIMIZE
SOLVER XA FROM LINE 103

**** SOLVER STATUS 1 NORMAL COMPLETION
**** MODEL STATUS 1 OPTIMAL
**** OBJECTIVE VALUE 453.0000

RESOURCE USAGE, LIMIT 0.000 100.000
ITERATION COUNT, LIMIT 19 1000

GAMS/XA Jun 14, 2002 WIN.XA.XA 20.7 011.024.040.VIS

Memory estimate (computed): 0.56MB

Copyright (c) 2000, 2001 by SUNSET SOFTWARE TECHNOLOGY.
1613 Chelsea Road, Suite 153
San Marino, California 91108 U.S.A.
All Rights Reserved Worldwide.
Telephone 626-441-1565 FAX 626-441-1567
EMAIL: jim@sunsetsoft.com
<http://www.sunsetsoft.com>

Licensed Solely To: GAMS DEVELOPMENT CORPORATION - 1208802
WASHINGTON, DC

STATISTICS - gams Tue Jan 13 09:34:21 2004
xa VERSION 13.68 NT DLL USABLE MEMORY 0.5 MBYTE
ENV ID 1 SOLVE NUMBER 1
VARIABLES 84
0 LOWER, 0 FIXED, 0 UPPER, 1 FREE
CONSTRAINTS 53
0 GE, 52 EQ, 0 LE, 1 NULL/FREE, 0 RANGED.
236 NON-ZEROS WORK 46,262
MINIMIZATION.
GAMS DEVELOPMENT CORPORATION - 1208802
WASHINGTON, DC

**** REPORT SUMMARY : 0 NONOPT
0 INFEASIBLE
0 UNBOUNDED

104 VARIABLE TOTALTIME.L = 453.00 total time to satisfy
all fire missions

---- 104 VARIABLE X.L amount of flow on each arc

	N1	N4	N7	N8	N9	N17
N2	1.00					
N4			2.00	2.00		

N5	2.00				
N6	2.00				
N9	3.00				1.00
N10				2.00	
N11				1.00	
N12				1.00	
N13				1.00	
N19	4.00				
N29	4.00				
N51	2.00				

104 VARIABLE X.L amount of flow on each arc

+	N18	N19	N27	N28	N29	N37
N9	1.00					
N19			1.00	1.00		
N20		1.00				
N23		2.00				
N24		3.00				
N29					1.00	
N30				2.00		
N31				1.00		
N34				3.00		

104 VARIABLE X.L amount of flow on each arc

+	N38	N39	N42	N43	N45	N46
N1		5.00				
N29	1.00					
N39			1.00	1.00	1.00	1.00
N40		1.00				

104 VARIABLE X.L amount of flow on each arc

+	N48	N49	N53	N54	N55	N56
N0			3.00			
N1			3.00	3.00	3.00	
N39	1.00	1.00				

104 VARIABLE X.L amount of flow on each arc

+	N57
N0	3.00

EXECUTION TIME = 0.000 SECONDS 1.6 Mb WIN207-133

USER: Michael R. Anderson G030318:1008CP-WIN
 US Army TRAC, Joint Analysis Division DC904

**** FILE SUMMARY

INPUT C:\WINDOWS\GAMSDIR\COMPOSITE_HI.GMS
OUTPUT C:\WINDOWS\GAMSDIR\COMPOSITE_HI.LST

BIBLIOGRAPHY

GOVERNMENT PUBLICATIONS

Headquarters, Department of the Army. *FM 7-0 Training the Force*. Washington DC, 22 October 2002.

Headquarters, Department of the Army. *FM 22-100, Army Leadership*. Washington DC, 31 August 1999.

Headquarters, Department of the Army. *TRADOC FM 3-09.21, TACTICS, TECHNIQUES, AND PROCEDURES FOR THE FIELD ARTILLERY BATTALION*. Washington DC, 22 March 2001.

Headquarters, United States Army Training and Doctrine Command. *TRADOC Pamphlet 525-3-9: Objective Force Fires and Effects Concept of Operation (Coordinating Draft)*, Fort Monroe, VA, 02 Jul 2003

Headquarters, United States Army Training and Doctrine Command. *TRADOC Pamphlet 525-3-90, The United States Army Objective Force Operational and Organizational Plan Maneuver Unit of Action. (Coordinating Draft)*, Fort Monroe, VA, 30 June 2003, Change 2.

BOOKS

Ahuja, Ravindra K, Thomas L Magnanti, James B. Orin. *Network Flows*. Upper Saddle River, NJ: Prentice-Hall, 1993

Box, G.E.P., W.G. Hunter, and J.S. Hunter, *Statistics for Experimenters, An Introduction to Design, Data Analysis, and Model Building*. New York: John Wiley and Sons, 1978.

Canada, John R. and William G. Sullivan, *Economic Multiattribute Evaluation of Advanced Manufacturing Systems*. Englewood Cliffs: Prentice Hall, 1989.

Devore, Jay L. *Probability and Statistics for Engineering and the Sciences*, 4th ed. Pacific Grove: Duxbury Press, 1995.

Doerner, Dietrich. *The Logic of Failure: Why Things Go Wrong and What We Can Do to Make Them Right*. New York: Metropolitan Books, 1996.

Naveh, Shimon. *In pursuit of Military Excellence: The Evolution of Operational Theory*. Portland, OR: Frank Cass Publishers, 1997.

Senge, Peter M. *The Fifth Discipline: The Art and Practice of the Learning Organization*. New York: Doubleday Currency, 1990.

Van Creveld, Martin. *Command In War*. Cambridge MA: Harvard University Press, 1985.

Waldrop, M. Mitchell, *Complexity, The Emerging Science at the Edge of Order and Chaos*, New York, NY; Simon and Schuster, 1992.

ARTICLES

Cebrowski, Arthur K., and John J. Garstka. "Network-Centric Warfare: Its Origin and Future." *US Naval Institute Proceedings* (January 1998). Available online at <https://www.usni.org/Proceedings/Articles98/PROcebrowski.htm>. Site last visited 05 November, 2003.

Cheek, Gary H. "Why Can't Joe Get the Lead Out?" *Field Artillery Journal* (January-February 2003): 33-37.

Murray, Scott F. "Battle command, decisionmaking [sic], and the battlefield panopticon." *Military Review* (Jul/Aug 2002): 46-51

Schneider, James J. "The Theory of the Empty Battlefield." *RUSI: Journal of the Royal United Services Institute for Defence Studies* (September 1987): 36-44.

MONOGRAPHS AND THESIS'S

Herman, John W. "Self-Synchronized Fire in Support of Ship-to-Objective Maneuver (STOM)." Research Paper, Naval War College, 04 Feb 2002

Witsken, Jeffrey R. "Network-Centric Warfare: Implications for Operational Design". Research Paper, School of Advanced Military Studies, May 2002.

OTHER REFERENCES

_____. "Information Paper, Observations on the Emergence of Network-Centric Warfare." Available at <http://www.dtic.mil/jcs/j6/education/warfare.html>, accessed 11 Sep 2003.

Turabian, Kate L. *A Manual for Writers of Term Papers, Theses, and Dissertations*. 6th ed. Chicago: University of Chicago Press, 1996.