

Self-oscillating Ultrasonic Micro-motor and It's Application

A. Iino*, K. Suzuki, M.Suzuki, K.Nitadori, M.Kasuga

Seiko Instruments Inc. 8, Nakase 1-chome, Mihama-ku, Chiba-shi, Chiba 261-8507, Japan

Abstract

We have developed an ultrasonic micro-motor, which is expected to be used in a broad range of fields. The ultrasonic micro-motor, which can be driven by a single signal and change the rotational direction of a rotor easily by only selecting the electrode to apply drive signal, can easily construct a self-oscillating circuit and simplify the drive circuit. We have also simplified the motor structure which is easy to miniaturize and mass-produce. We applied the ultrasonic micro-motor to some functions in watches and clocks. Furthermore we have tried precise positioning control with the ultrasonic micro-motor, and consequently it's potential for the ultra-precision positioning has been revealed.

1. Introduction

The ultrasonic motor is an advanced actuator which uses both elastic vibration excited by piezoelectric ceramics and friction between a vibrator and a rotor. It has a lot of superior characteristics caused by the principle, and is expected as new driving sources in many devices. We have had a great expectation for the potential for the ultrasonic motor as a micro-actuator, and have developed. Especially, we thought the characteristics of small size and large torque are helpful to miniaturize the devices. But the ultrasonic motor has some problems, they are the complicated drive circuit as compared to one for the conventional electro magnetic motor and high drive voltage. They are the main problems to use in miniaturized devices such as watches, especially battery operated devices, practically.

To overcome these problems, we have set our sights on the typical crystal oscillator, which constructs a self-oscillating circuit. Our basic idea is constructing a self-oscillating circuit by putting an ultrasonic motor with piezoelectric element in place of a crystal resonator and simplifying the drive circuit. And we have developed a new standing wave type motor. The realization of the new principle drive method^[1,2] which can be driven by only single signal enabled us to adopt a self-oscillating circuit. We call this ultrasonic motor, which is driven by it's own oscillation with electric elements, "a self-oscillating ultrasonic motor". We also succeeded in further miniaturization of the ultrasonic micro-motor to 4.5 mm in diameter by simplifying the motor structure, especially the rotor pressuring mechanism and the bearing mechanism. Additionally we've realized to mass-produce the motor and applied it to some functions in watches and clocks. Of course a self-oscillating ultrasonic micro-motor can be operated by even a coin battery.

Report Documentation Page

Form Approved
OMB No. 0704-0188

Public reporting burden for the collection of information is estimated to average 1 hour per response, including the time for reviewing instructions, searching existing data sources, gathering and maintaining the data needed, and completing and reviewing the collection of information. Send comments regarding this burden estimate or any other aspect of this collection of information, including suggestions for reducing this burden, to Washington Headquarters Services, Directorate for Information Operations and Reports, 1215 Jefferson Davis Highway, Suite 1204, Arlington VA 22202-4302. Respondents should be aware that notwithstanding any other provision of law, no person shall be subject to a penalty for failing to comply with a collection of information if it does not display a currently valid OMB control number.

1. REPORT DATE 00 JUN 2003	2. REPORT TYPE N/A	3. DATES COVERED -	
4. TITLE AND SUBTITLE Self-oscillating Ultrasonic Micro-motor and Its Application		5a. CONTRACT NUMBER	
		5b. GRANT NUMBER	
		5c. PROGRAM ELEMENT NUMBER	
6. AUTHOR(S)		5d. PROJECT NUMBER	
		5e. TASK NUMBER	
		5f. WORK UNIT NUMBER	
7. PERFORMING ORGANIZATION NAME(S) AND ADDRESS(ES) Seiko Instruments Inc. 8, Nakase 1-chome, Mihama-ku, Chiba-shi, Chiba 261-8507, Japan		8. PERFORMING ORGANIZATION REPORT NUMBER	
9. SPONSORING/MONITORING AGENCY NAME(S) AND ADDRESS(ES)		10. SPONSOR/MONITOR'S ACRONYM(S)	
		11. SPONSOR/MONITOR'S REPORT NUMBER(S)	
12. DISTRIBUTION/AVAILABILITY STATEMENT Approved for public release, distribution unlimited			
13. SUPPLEMENTARY NOTES See also ADM001697, ARO-44924.1-EG-CF, International Conference on Intelligent Materials (5th) (Smart Systems & Nanotechnology)., The original document contains color images.			
14. ABSTRACT			
15. SUBJECT TERMS			
16. SECURITY CLASSIFICATION OF:			17. LIMITATION OF ABSTRACT
a. REPORT unclassified	b. ABSTRACT unclassified	c. THIS PAGE unclassified	UU
			18. NUMBER OF PAGES 12
			19a. NAME OF RESPONSIBLE PERSON

Furthermore, we tried precise positioning with a self-oscillation circuit, which is a simple construction, and a simple control system, and consequently confirmed the high ability. To put it concretely, we succeeded in the positioning of 0.01 degree resolution with the motor of 15mm in diameter. We expect the ultrasonic micro-motor to be the actuator for the ultra-precision positioning system in the field of nano-technology. We also describe the latest trials in our development.

2. Principle and basic construction

2.1 Principle

The ultrasonic motors use vibration of an elastic body, therefore there are many different kinds of drive methods depending on the type of vibration generated^[3]. There are mainly classified into two categories, the progressive wave type and the standing wave type.

Currently, the most popular type, which is practically used, is the progressive wave type. We also had developed the motor with a disk vibrator and miniaturized to 10mm in diameter^[4]. But generally, the drive circuit in this type of motor is very complicated, large and expensive, because it needs the booster circuit with two transformers to two signals with different periodical phases, namely SIN and COS waves, and an automatic frequency tracing circuit to maintain the stability of the motor drive with the change of temperature and load.

That is one of the obstacles to use the ultrasonic micro-motor in portable devices, even if the motor is very tiny size. To these problems, we applied a self-oscillating circuit, especially the standard crystal oscillator in watches called “Colpitts oscillator”, as the drive circuit shown in Fig.1^[2]. The self-oscillating circuit consists of a return circuit and an amplifier circuit. A return circuit filters by using a resonance of the vibrator. Then, the signal with natural frequency of the vibrator is amplified by an amplifier and sent back to the vibrator to create a continuous vibration of both the electric signal and the vibrator, and drive the rotor. Conditions for the oscillation is as follows.

$$|\alpha| \times |\beta| \geq 1 \quad (1)$$

$$\angle \alpha + \angle \beta = 2\pi n \quad (2)$$

Here α :return circuit β :amplifier circuit n :1,2,...

In this circuit, “Colpitts oscillator”, the vibrator with piezoelectric element works as an inductance between a resonant point and an anti-resonant point and construct a resonance circuit (return circuit) with two capacitors. Structuring the circuit in this way makes the oscillating frequency adjust near a resonance

point, which is suitable for the drive, to the change of the temperature, voltage and load. Thus, a piezoelectric element (ceramics) is an intelligent material working as both a resonator and an actuator.

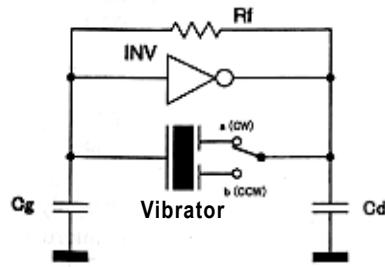

Fig.1 Construction of drive circuit using “Colpitts oscillator”

Owing to the complexity of creating a self-oscillating circuit for the progressive wave type, which needs two signals with different phase, this time we use the standing wave type which needs only single signal. We use a circular plate as an elastic body to thin the ultrasonic motor as possible as we can. Fig.2 shows the relationship between the location of the projections on the elastic body used to produce the output and the electrode pattern of the piezoelectric element, which produces the vibration. The electrode on a surface of the circular shape of the piezoelectric element shown in Fig.2 is divided into 12 parts of 1/4 wave lengths. The parts of each electrode are polarized alternately in pairs of positive (+) and negative (-). Every other pattern is shortened, creating the two zones shown by the shaded area and the non-shaded one in Fig.2. By the way, the common electrode is deposited on all another surface of the piezoelectric element. The surface with the common electrode of the piezoelectric element is bonded to the bottom of the vibrator, and generates the three wave vibration in the circumference direction. The six projections on the vibrator are placed on the border between parts of the same polarity. With this configuration, when a drive signal is applied to the shaded area of the electrode, the projections leaning to the left rise and the ones leaning to the right fall even though the position of the hills and valleys alternate in half periods. The rotor is then driven to the left by the three rising projections. When the driving signal is applied to the non-shaded area, the whole process is reversed (see Fig.3). By driving the rotor in this manner, it is possible to easily change the direction of the rotor movement. In the driving circuit, shown in Fig.1, the shaded and the non-shaded area of the electrodes respectively correspond to “a” and “b”.

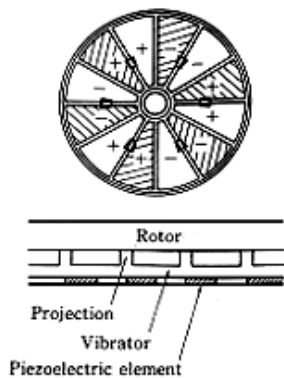

Fig.2 Relationship between projections and electrodes

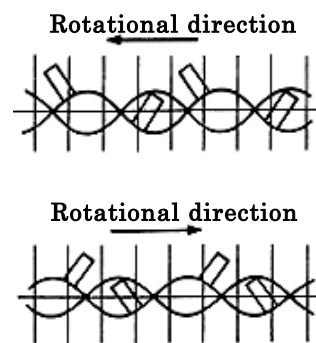
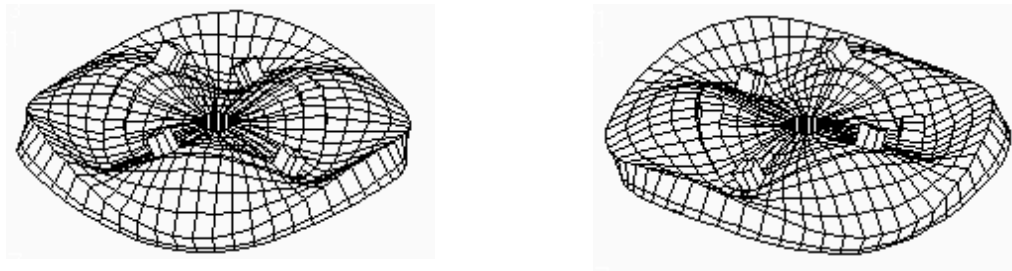

Fig.3 Relationship between motion of projections and rotational direction of rotor

Fig 4 shows the B_{13} mode of the elastic body we use this time, which has 1 nodal circle and 3 nodal diameters, which is analyzed by FEM considering piezoelectric effect. Though a degenerate mode exists, the vibrator is designed not to excite the degenerated mode by optimizing the design parameters of the vibrator^[5]. Because the excitation of degenerated mode affect the stability of both self-oscillation and motor drive. And the projections are designed so that the natural frequency of 1st bending mode of projections can be much higher than the one of B_{13} mode of the disk part of the vibrator.



(a) Driving mode

(b) Degenerate mode

Fig.4 Vibration mode of vibrator

As some examples, Fig.5 shows the relationships between frequency and admittance near the resonant point to be used in two vibrators with different design parameters.

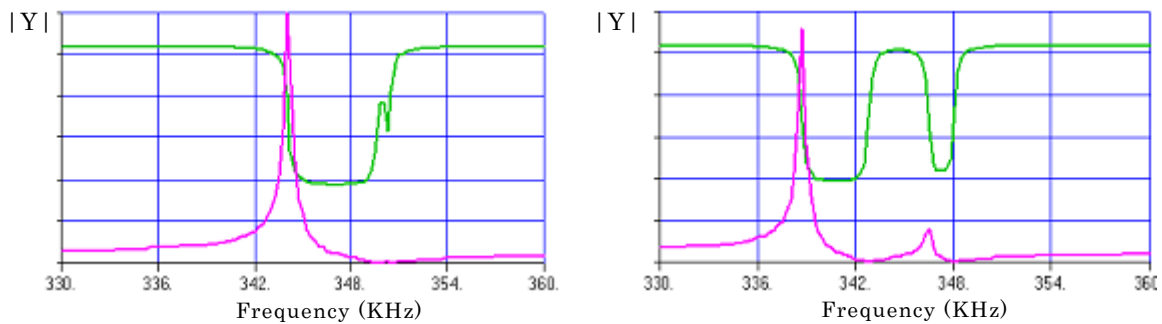

(a) Shape A

(b) Shape B

Fig.5 Relationship frequency and admittance of two vibrators

Fig.5(a) is the optimized vibrator with 8mm in diameter. Fig.6 shows the relationship between frequency and admittance in this vibrator. Any resonant points have not appeared near the resonant point of the B_{13} mode and the admittance value at the resonance is large enough to construct a self-oscillating circuit caused by using the electrode pattern of Fig.2. And though there are some resonant points in the higher frequency range than at the resonant frequency of B_{13} mode, it realizes stable oscillation to optimize the electric elements which construct filters with piezoelectric element. These things indicate that the electrode pattern shown in Fig.2 is suitable to the self-oscillating ultrasonic motor.

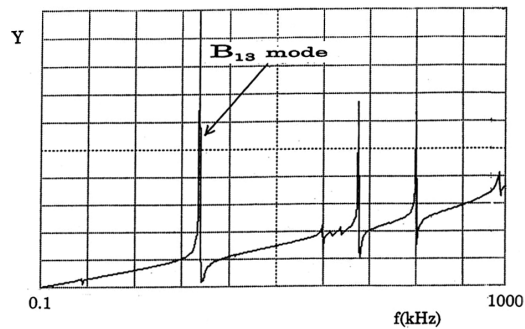

Fig.6 Relationship between frequency and admittance

2.2 Basic construction

Fig.7 shows the cross-sectional view of the ultrasonic micro-motor. We fabricate the vibrator out of aluminum alloy and reduce vibration loss during miniaturization by supporting the vibrator in the center, which is the nodal point, at one point, and consequently obtain a high Q_m value (about 1000). The three point contact from the three waves also help to limit disturbance from undulation and roughness at the micro level.

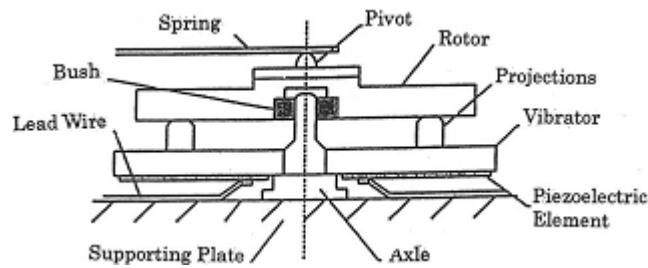

Fig.7 Cross-sectional view of ultrasonic micro-motor

The projections, which is set at the position with the largest vibration displacement to the radial direction, also help to magnify the displacement using the lever principle at the same time as selecting the vibration components in a particular direction. The rotor is made of wear-resistant engineering plastic (PPS), which is the composite material containing some reinforce fiber such as carbon fiber and so on. A bush in the center of the rotor, which is actually used in a watch mechanism, act as a bearing. A flat spring, which is attached at one point to a spring base, applies pressure to a pivot on the center of the upper part of the rotor to provide the optimum driving condition between the sliding part of the rotor and the projections on the vibrator.

The new rotor pressurizing mechanism and the bearing mechanism with the flat spring, the pivot and a bush enabled miniaturization beyond the limit of the size of mechanism with conventional rolling bearings and reduced rotational loss at the same time. Actually we can't obtain a micro-rolling bearing to suit the ultrasonic micro motor of this size. And we were able to strengthen the electrical field and lower the necessary drive voltage by using a thin piezoelectric element of only $80 \mu\text{m}$ to be driven by only a 1.5V battery.

2.3 Positioning system with self-oscillating ultrasonic micro-motor

There is no micro-motor for precise positioning, because the smaller the size is, the rotational speed becomes faster which makes it harder to control. And for example, in the case of electro magnetic stepping motor, it is hard to miniaturize the stepping motor for positioning such as a HB type stepping motor, which is for precise positioning, because it's structure is very comprehensive.

On the other hand, we believe the best feature of the ultrasonic micro-motor is the ability for precise positioning, in comparison with electromagnetic motor, though it's driver and controller are complicated. And no energy consumption at a standstill is a great advantage for the battery operated devices, though the conventional servo system consume electric power during this time.

We have tried precise positioning control with a simple driver of self-oscillating circuit and a simple controller. The controller has just simple functions that detects the signals from an encoder and calculates the position and outputs the control signals for ON/OFF and CW/CCW (change of rotational direction) to the drive circuit to the difference between the present position and the target position. All input and output signals in this system are digital signals, and hence it's easy to construct a circuit.

We also developed a micro- encoder which suits ultrasonic micro-motor with 4.5mm in diameter. The thickness of the sensor part in the micro-encoder is only 5mm^[6]. Fig.8 is the appearance of the micro-encoder with the ultrasonic micro-motor. Fig.9 shows the behavior, which is the relationship between time and position, during positioning with the system. This figure indicates the fast response of the ultrasonic micro-motor. We also succeeded in precise positioning of 0.01 degree resolution with the positioning system and the ultrasonic micro-motor with 15mm in diameter and realized the high ability for precise positioning. We expect this ultrasonic micro-motor to be conventional actuator for positioning for a lot of devices such as portable devices and so on. Actually we try to apply to some devices such as optical communication device and so on with this system.

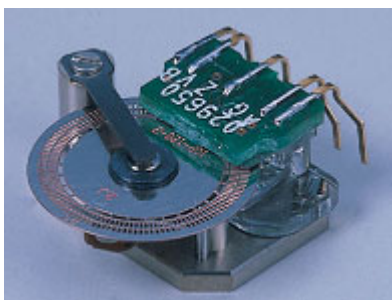

Fig.8 Appearance of ultrasonic micro-motor with micro-encoder

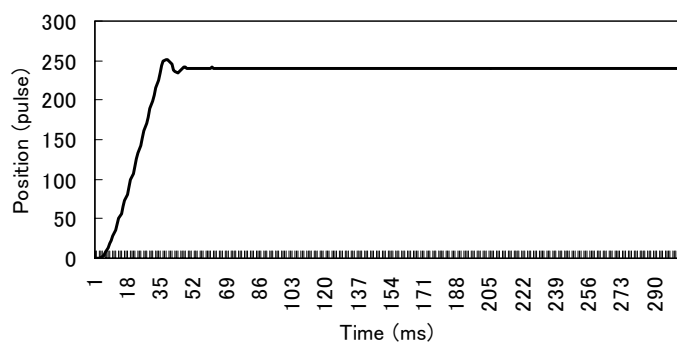

Fig.9 Relationship between time and position during position

3. Application to watch and clock

In the analog quartz watches, since the birth of it, electro magnetic stepping motors with two pole permanent magnet have been used to drive the hands. However, to the current of the times of demands for many functions, intelligence and reliability not to be affected by magnetic fields, it is increasingly difficult to develop reliable timepieces to satisfy the needs of the market place.

3.1 Vibration alarm

We succeeded in applying the ultrasonic micro-motor with 8mm in diameter to the vibrating alarm function in watches shown in Fig.10 at a price similar to conventional watches^[2]. The ultrasonic micro-motor can be seen through the little window at the 6 o'clock position on the dial. The vibration alarm alerts the user at a preset time by vibrating the watch. The vibration is generated by the centrifugal forces produced by fast and intermittent rotation of the rotor with an off-center weight.



Fig.10 Appearance of watch with vibration alarm function

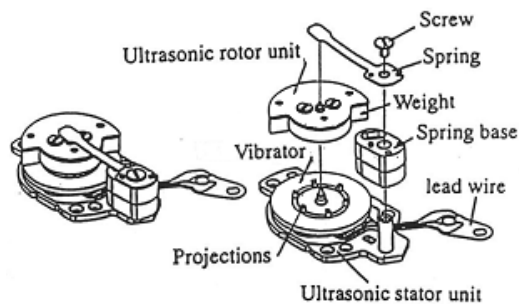

Fig.11 Overall view and expanded view of the ultrasonic micro-motor

Fig.11 shows an overall view and a expanded view of the ultrasonic micro-motor we applied to the vibration alarm. Basically, the structure is nearly same as the one shown in Fig.7. The off-center weight is placed on the outside of the projections on the vibrator. The drive circuit we used for the vibration alarm is shown in Fig.12. The drive circuit is made up of a return circuit, which consists of two condensers and a piezoelectric element (vibrator), and an amplifier circuit with two inverters and a booster circuit, which consists of a transistor and a coil. As seen in the figure, without the booster circuit, which is separated by the dotted lines, the structure of the circuit is the same as a typical Colpitts oscillator shown in Fig.1.

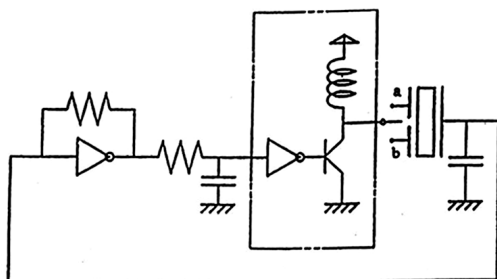

Fig.12 Self-oscillation circuit with booster circuit

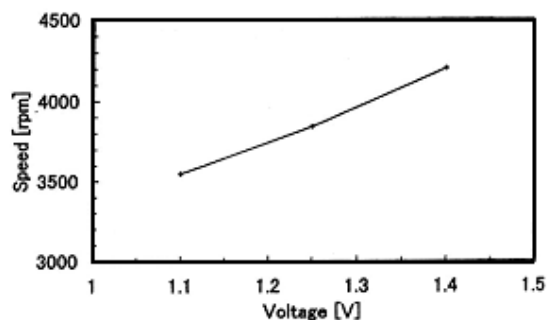

Fig.13 Relationship between applied voltage and rotational speed

Fig.13 shows the relationship between the applied voltage and the rotational speed. This ultrasonic micro-motor can be driven stably at low voltage, even in the end of battery life. Fig.14 shows the relationship between temperature and rotational speed. Though a resonant point shifts with the change of temperature shown in Fig.15, the change of speed through various temperatures is small. This graph proves the effectiveness of the self-oscillating circuit, though the structure of this circuit is very simple.

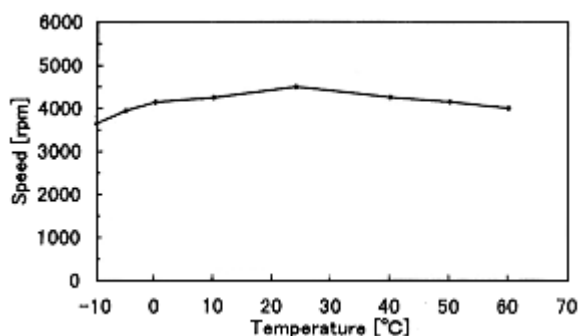

Fig.14 Relationship between temperature and rotational speed

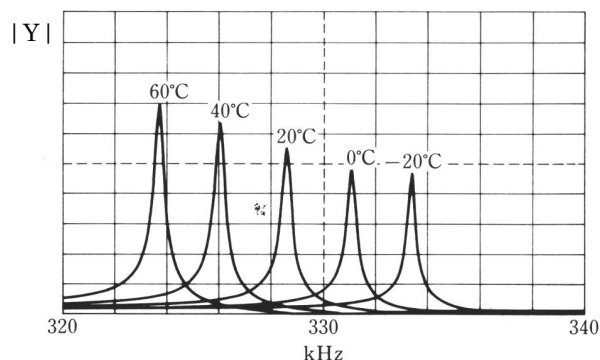

Fig.15 Relationship between temperature and resonant point

3.2 Drive of calendar mechanism

We applied the ultrasonic micro-motor with 4.5mm in diameter to the driving source of calendar mechanism shown in Fig.16, and realized the world's first women's quartz analog perpetual calendar watch^[2]. In this function, the motor move the date wheel for two or more dates in the case of months with 30days or less. The calendar automatically valid through February 28, 2100. Fig.17 shows the appearance of ultrasonic micro-motor used in this mechanism. This ultrasonic micro-motor is 4.5mm in diameter and 2.5mm in thickness, and the world's smallest size for use. The characteristics of the ultrasonic micro-motor is that the starting torque is 0.2g·cm and the no-load rotational speed is 2000rpm at 3V DC. The driving frequency is about 630kHz. The starting torque is more than ten times of electromagnetic stepping motor used in watches. The output power of the ultrasonic micro-motor is transmitted from the rotor pinion on the rotor to the intermediate wheel, to the date wheel, to the date dial.

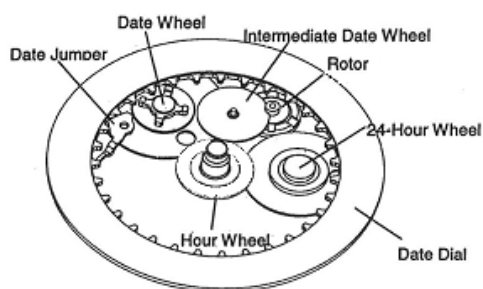

Fig.16 Construction of calendar mechanism

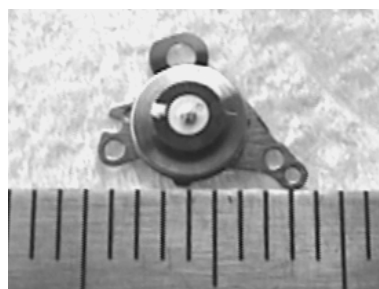

Fig.17 Appearance of ultrasonic micro-motor(ϕ 4.5 m m)

Fig.18 shows the drive circuit used in this movement. It makes the control of rotational direction possible to put 3-state buffers in front of two electrode parts respectively. According to the control signals (H or L

logic state) to two 3-state buffers, the state of buffer changes active or non-active and the electrode which a 3-state buffer apply drive signal to is selected. The 3-state buffers also work as amplifier and the drive circuit can be driven by a 3V lithium coin battery, even without any booster circuit.

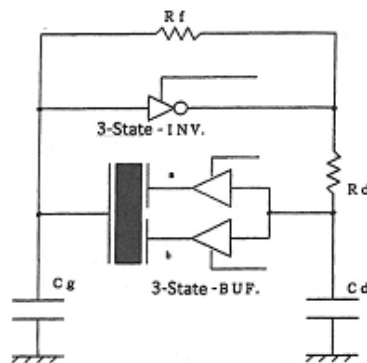

Fig.18 Drive circuit for calendar mechanism

3.3 Drive of windup doll

The ultrasonic micro-motor with 8mm in diameter is also used for novelty clock^[6]. The appearance of the clock is shown in Fig.19. The ultrasonic micro-motor is mounted in a thin disk over the clock. The doll on the disk usually dances rotating intermittently, and strikes the hours dancing smartly to the music. The ultrasonic micro-motor realizes quick turn and smart dance of the doll what electromagnetic motor can't perform, the miniaturization of the mechanism and low energy consumption.



Fig.19 Appearance of novelty clock

4. Some trials in the latest development

We focus the targets in our development on two subjects, which are the further miniaturization of the ultrasonic micro-motor and the application to the ultra-precision positioning.

4.1 Miniaturization of the motor

We continue our study for the further miniaturization of ultrasonic micro-motors^[7]. Fig.20 shows an example of ultrasonic micro-motors we have newly developed. The motor size is 2.0mm in width and 1.0mm in height, and No-load rotational speed is 500rpm at 5.0Vpp. The principle is similar to the one of

self-oscillating ultrasonic micro-motors described above. Fig.21 shows the vibration modes of the vibrator. Piezoelectric ceramics with four electrodes is deposited to the vibrator of a square plate. Selecting the two electrodes at the opposite angle, to which drive signals is applied, changes the vibration mode, and changes the rotational direction of the rotor. The use of a square plate as a vibrator realize a simple process for the motor fabrication, which is easy to mass-produce. Namely, the process is as follows: 1)Forming of elastic body having plural vibrators 2)Bonding of piezoelectric ceramics plate to the elastic body or depositing of piezoelectric ceramics to the elastic body 3)Dividing elastic body with piezoelectric ceramics into each vibrators.

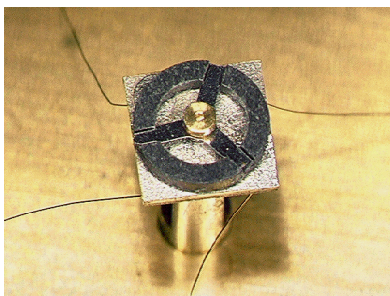
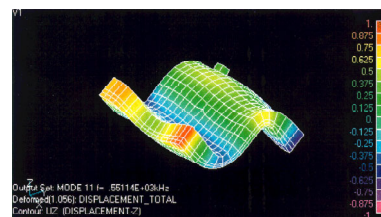
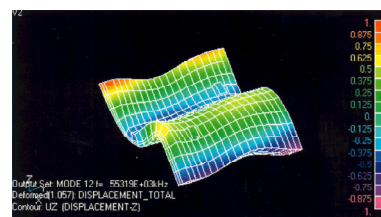

Fig.20 Appearance of newly developed ultrasonic micro-motor



(a) Rotational direction: CW



(b) Rotational direction: CCW

Fig.21 Vibration mode of square plate vibrator

4.2 Linear actuator for ultra-precise positioning

Fig.22 shows the principle of the ultrasonic linear micro-actuator. Fig.23 shows the construction of the vibrator and the connection with the drive circuit simply. Fig.24 shows the appearance of a micro-stage with the ultrasonic linear micro-actuator. The vibrator is made of multilayer ceramics and the actuator has some merits, that is small body, low drive voltage and large driving force. The vibrator of multilayer ceramics contains both the layers to excite longitudinal mode and the layers to excite the bending mode. The combination of two modes caused by applying two signals with different phase to the vibrator makes the elliptic motion of projections which are set at the loop point of bending mode and move the moving body. These construction of the vibrator makes it possible to excite two modes independently in the vibrator. To put it in other words, controlling locus of the elliptic motion changes the driving condition of the actuator such as speed, driving force. We believe that these characteristics suit the actuator used for the ultra-precise positioning in the field of nano-technology as well as portable devices. By the way, the size of the vibrator is about 20mm in length, 5.5mm in width and 2.0mm in thickness. The no-load speed is

150mm/s and the starting force is 60gf at 5Vpp .

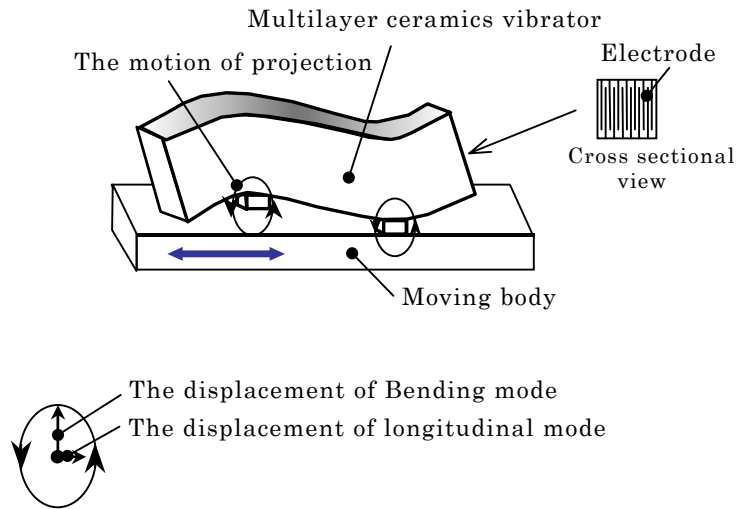

Fig.22 Principle of ultrasonic linear micro-actuator

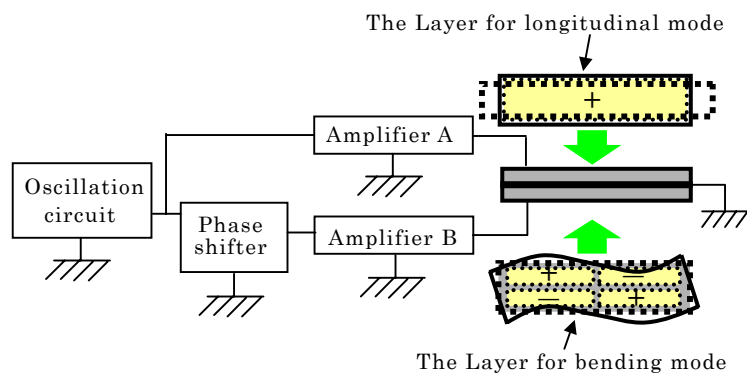

Fig.23 Construction of vibrator and connection with drive circuit

5. Conclusion

We have developed the self-oscillating ultrasonic micro-motor and miniaturized with new concept and applied to some functions in watches and clocks. We also have tried precise positioning control with this motor. Though this development, following achievements have obtained.

- 1). We established the new principle ultrasonic motor which can be driven by only single signal and reverse direction by selecting the electrode to apply drive signal and easily construct a self-oscillating circuit.
- 2). The realization of the self-oscillation circuit with the ultrasonic motor made a drive circuit very simple.
- 3). We have also simplified the motor structure and miniaturized to 4.5mm in diameter and 2.5mm in thickness and succeeded in mass-production using the high precision machining gained over the years through the manufacture of watches.
- 4). We have developed the micro-encoder to suit the ultrasonic micro-motor and constructed the simple positioning system with the self-oscillating ultrasonic micro-motor, and realized the high ability, though it is just a simple system.

5). We applied the ultrasonic micro-motor to some functions of it all, vibration alarm, the drive of calendar mechanism in watches, and the drive of windup doll in clocks, and the effectiveness as a micro-actuator was confirmed.

We expect the ultrasonic micro-motor and positioning system to be used in a lot of devices such as precise machines, optical devices, portable information devices, medical devices, and so on, in place of conventional electromagnetic motors. Furthermore, we develop new ultrasonic micro-motors which are the more miniaturized motor and the linear motor to be used for ultra-precision positioning in a field of nano-technology for the future.

References

1. T.Takano, Y.Tomikawa and C.Kusakabe, "Same Phase Drive-Type Ultrasonic Motors Using Two Degenerate Bending Vibration Modes of a Disk", IEEE TRANSACTIONS ON ULTRASONICS. FERROELECTRICS. AND FREQUENCY CONTROL, VOL.39, NO.2. (MARCH 1992) 13-19
2. A.iino, K.Suzuki, M.Kasuga, M,Suzuki, T.Ymamanaka, "Development of a Self-oscillating ultrasonic micro-motor and its application to a watch", Ultrasonics 38(2000)54-59
3. S.Ueha, Y.Tomikawa, "Ultrasonic Motors", OXFORD SCIENCE PUBLICATIONS (1993)
4. T.Satoh, "Vibration Alarm Analog Quartz Watch with Ultrasonic Micro-motor", Journal of the Horological Institute of Japan, (1992) 141,37-54
5. A.iino, S.Watanabe,M.Kasuga, "The Influence of design parameters to the Vibration Modes on Single-signal-drive-type Ultrasonic Motors using Flexural Disk Vibrators", TECHNICAL REPORT OF IEICE. US2002-113 (2003-02) 1-6
6. D.Ichiro, "Application of Ultrasonic Motor to Clock", ULTRASONIC TECHNOLOGY, (1998-07) 46-47
7. M.Kasuga, A.Iino, "Ultrasonic Micro-motor", The Japan Society for Precision Engineering Vol.68, No.5, 2002