



**NAVAL  
POSTGRADUATE  
SCHOOL**

**MONTEREY, CALIFORNIA**

**THESIS**

**NUCLEAR POWER SYSTEMS FOR MANNED  
MISSION TO MARS**

by

Scott James McGinnis

December 2004

Thesis Advisor:  
Second Readers:

Sherif Michael  
Daniel Bursch  
Oscar Biblarz

**Approved for public release; distribution is unlimited.**

THIS PAGE INTENTIONALLY LEFT BLANK

REPORT DOCUMENTATION PAGE			Form Approved OMB No. 0704-0188
Public reporting burden for this collection of information is estimated to average 1 hour per response, including the time for reviewing instruction, searching existing data sources, gathering and maintaining the data needed, and completing and reviewing the collection of information. Send comments regarding this burden estimate or any other aspect of this collection of information, including suggestions for reducing this burden, to Washington headquarters Services, Directorate for Information Operations and Reports, 1215 Jefferson Davis Highway, Suite 1204, Arlington, VA 22202-4302, and to the Office of Management and Budget, Paperwork Reduction Project (0704-0188) Washington DC 20503.			
1. AGENCY USE ONLY (Leave blank)	2. REPORT DATE December 2004	3. REPORT TYPE AND DATES COVERED Master's Thesis	
4. TITLE AND SUBTITLE: Space Nuclear Power Systems for Manned Mission to Mars			5. FUNDING NUMBERS
6. AUTHOR(S) Scott James McGinnis			
7. PERFORMING ORGANIZATION NAME(S) AND ADDRESS(ES) Naval Postgraduate School Monterey, CA 93943-5000			8. PERFORMING ORGANIZATION REPORT NUMBER
9. SPONSORING /MONITORING AGENCY NAME(S) AND ADDRESS(ES) N/A			10. SPONSORING/MONITORING AGENCY REPORT NUMBER
11. SUPPLEMENTARY NOTES The views expressed in this thesis are those of the author and do not reflect the official policy or position of the Department of Defense or the U.S. Government.			
12a. DISTRIBUTION / AVAILABILITY STATEMENT Approved for public release; distribution is unlimited.			12b. DISTRIBUTION CODE A
13. ABSTRACT (maximum 200 words)  Nuclear power is the next enabling technology in manned exploration of the solar system. Scientists and engineers continue to design multi-megawatt power systems, yet no power system in the 100 kilowatt, electric, range has been built and flown. Technology demonstrations and studies leave a myriad of systems from which decision makers can choose to build the first manned space nuclear power system. While many subsystem engineers plan in parallel, an accurate specific mass value becomes an important design specification, which is still uncertain. This thesis goes through the design features of the manned Mars mission, its power system requirements, their design attributes as well as their design faults. Specific mass is calculated statistically as well as empirically for 1-15MWe systems. Conclusions are presented on each subsystem as well as recommendations for decision makers on where development needs to begin today in order for the mission to launch in the future.			
14. SUBJECT TERMS Space Nuclear Power, Mars, Manned Mars Mission, Nuclear Electric Propulsion, Specific Mass			15. NUMBER OF PAGES 105
			16. PRICE CODE
17. SECURITY CLASSIFICATION OF REPORT Unclassified	18. SECURITY CLASSIFICATION OF THIS PAGE Unclassified	19. SECURITY CLASSIFICATION OF ABSTRACT Unclassified	20. LIMITATION OF ABSTRACT UL

THIS PAGE INTENTIONALLY LEFT BLANK

**Approved for public release; distribution is unlimited**

**NUCLEAR POWER SYSTEMS FOR HUMAN MISSION TO MARS**

Scott J. McGinnis  
Lieutenant, United States Navy  
B.S., United States Naval Academy, 1997

Submitted in partial fulfillment of the  
requirements for the degree of

**MASTER OF SCIENCE IN ASTRONAUTICAL ENGINEERING**

from the

**NAVAL POSTGRADUATE SCHOOL  
December 2004**

Author: Scott McGinnis

Approved by: Dr Sherif Michael  
Thesis Advisor

CAPT Daniel Bursch  
Second Reader

Dr Oscar Biblarz  
Second Reader

Dr Anthony J. Healey  
Chairman, Department of Mechanical and Astronautical  
Engineering

THIS PAGE INTENTIONALLY LEFT BLANK

## **ABSTRACT**

Nuclear power is the next enabling technology in manned exploration of the solar system. Scientists and engineers continue to design multi-megawatt power systems, yet no power system in the 100 kilowatt, electric, range has been built and flown. Technology demonstrations and studies leave a myriad of systems from which decision makers can choose to build the first manned space nuclear power system. While many subsystem engineers plan in parallel, an accurate specific mass value becomes an important design specification, which is still uncertain. This thesis goes through the design features of the manned Mars mission, its power system requirements, their design attributes as well as their design faults. Specific mass is calculated statistically as well as empirically for 1-15MWe systems. Conclusions are presented on each subsystem as well as recommendations for decision makers on where development needs to begin today in order for the mission to launch in the future.

THIS PAGE INTENTIONALLY LEFT BLANK

# TABLE OF CONTENTS

<b>I.</b>	<b>INTRODUCTION.....</b>	<b>1</b>
	A. GENERAL.....	1
	B. BACKGROUND.....	1
	1. Mars.....	1
	C. MARS EXPLORATION TIMELINE AND OBJECTIVES.....	2
	1. Initial Unmanned Missions.....	2
	2. First Manned Missions.....	2
	3. Follow-on Manned Missions.....	3
	D. SPACE NUCLEAR POWER.....	3
	1. SNAP-10A.....	9
	2. SP-100.....	9
	E. SPECIFIC POWER, SPECIFIC MASS.....	10
	1. Stored to Available.....	10
	2. Available to Propulsive Power.....	11
<b>II.</b>	<b>SPACE POWER SYSTEM COMPONENT OPTIONS.....</b>	<b>13</b>
	A. NUCLEAR SUBSYSTEMS.....	13
	1. Reactor.....	13
	a. <i>Fast versus Thermal</i> .....	13
	b. <i>Fuels</i> .....	15
	c. <i>Reactivity Control</i> .....	17
	2. Shielding.....	19
	a. <i>Shield Design Example</i> .....	21
	b. <i>Other Sources of Radiation</i> .....	22
	c. <i>Conclusion</i> .....	26
	B. POWER CONVERSION SUBSYSTEMS.....	26
	1. Static Power Conversion.....	26
	2. Dynamic Power Conversion.....	28
	a. <i>Rankine Cycle</i> .....	28
	b. <i>Brayton Cycle</i> .....	30
	c. <i>Stirling Cycle</i> .....	31
	d. <i>Comparison</i> .....	33
	C. HEAT REJECTION SUBSYSTEMS.....	35
	1. Heat Pipe Radiators.....	36
	2. Pumped Loop Liquid Metal.....	37
	3. Liquid Droplet Radiators.....	37
	D. MATERIALS.....	38
	1. Alloys.....	38
	a. <i>Needed Tests for Near and Long Term Space Nuclear Power System Flight</i> .....	40
	2. Lithium.....	41

<b>III.</b>	<b>DESIGN CONCEPTS .....</b>	<b>43</b>
<b>A.</b>	<b>PELLET BED REACTOR CONCEPT .....</b>	<b>43</b>
1.	Nuclear Subsystem.....	43
2.	Power Conversion Subsystem.....	44
3.	Heat Rejection Subsystem.....	44
<b>B.</b>	<b>POTASSIUM RANKINE SYSTEM .....</b>	<b>45</b>
1.	Nuclear Subsystem.....	45
a.	<i>Rocketdyne</i> .....	45
b.	<i>ORNL</i> .....	46
c.	<i>NASA</i> .....	46
2.	Power Conversion Subsystem.....	46
a.	<i>Rocketdyne</i> .....	46
b.	<i>ORNL</i> .....	47
c.	<i>NASA</i> .....	47
3.	Heat Rejection Subsystem.....	47
a.	<i>Rocketdyne</i> .....	47
b.	<i>ORNL</i> .....	47
c.	<i>NASA</i> .....	47
4.	Comparisons.....	47
<b>C.</b>	<b>SCALEABILITY OF THE SP-100 PROGRAM .....</b>	<b>49</b>
<b>D.</b>	<b>ADDITIONAL ANALYSIS OF POWER SYSTEM DESIGNS.....</b>	<b>50</b>
1.	Restart Capability.....	50
2.	Backup Power Requirements.....	50
3.	Power Management and Distribution.....	51
4.	Launch and Assembly Safety.....	52
5.	Attitude Determination and Control System .....	53
6.	Shield Requirements in Case of a Necessary Extra-Vehicular Activity (EVA).....	53
7.	Artificial Gravity.....	53
<b>IV.</b>	<b>THUMBRULES AND ASSUMPTIONS FOR NUCLEAR POWER SYSTEMS DESIGN 1MWE-15MWE .....</b>	<b>55</b>
<b>A.</b>	<b>NUCLEAR SUBSYSTEM.....</b>	<b>55</b>
1.	Reactor .....	55
2.	Shielding.....	56
<b>B.</b>	<b>POWER CONVERSION SUBSYSTEM .....</b>	<b>57</b>
<b>C.</b>	<b>HEAT REJECTION SUBSYSTEM.....</b>	<b>57</b>
<b>D.</b>	<b>SPECIFIC MASS.....</b>	<b>58</b>
1.	Specific Mass Breakdown by Thumbrule Approximation.....	58
2.	Empirical Method of Determining Specific Mass .....	59
<b>E.</b>	<b>MASS REDUCTION .....</b>	<b>60</b>
1.	Shield Mass Reduction .....	60
2.	Increasing Power Conversion Efficiency .....	60
a.	<i>Thermal Photovoltaics</i> .....	60
3.	Increasing Operating Temperatures.....	61
4.	Turbine Material Advances .....	62

5.	Overall Material Advances .....	62
6.	Advanced Radiator Concepts .....	62
V.	COMPARISON AND RECOMMENDATIONS .....	63
1.	Early Decisions and Project Prometheus.....	63
2.	Recommendations on Viable Multimegawatt Designs .....	64
3.	Recommendations on Technology Investment Decisions.....	65
VI.	CONCLUDING THOUGHTS.....	67
	APPENDICIES .....	69
1.	MARS MISSIONS PAST, PRESENT, AND FUTURE .....	69
2.	LAUNCH VEHICLE TO LEO COMPUTATION.....	70
a.	Bibliography for Launch Vehicle Computation .....	75
3.	EMPIRICAL DATABASE FOR SPECIFIC MASS CALCULATION ...	76
4.	MARS MISSION TIMING.....	79
1.	Ballistic Trajectories.....	79
a.	<i>Opposition</i> .....	79
b.	<i>Conjunction</i> .....	80
2.	Low-Thrust Trajectories.....	81
3.	Abort Scenarios.....	83
4.	Timing.....	83
	INITIAL DISTRIBUTION LIST .....	87

THIS PAGE INTENTIONALLY LEFT BLANK

## LIST OF FIGURES

Figure 1.	RTGs and Reactors currently in Space .....	4
Figure 2.	Space Vehicle Electric Power Requirement versus Duration of Mission Use .....	5
Figure 3.	Solar Energy Flux Available versus Actual Distance from the Sun.....	5
Figure 4.	Generic Nuclear Thermal Rocket .....	7
Figure 5.	Generic Nuclear Electric Vehicle .....	8
Figure 6.	SP-100 Design Layout .....	10
Figure 7.	Overall Specific Mass versus Electric Power Output of Launched and Conceptual Designs .....	12
Figure 8.	Empirical Energy Spectrum for Fission Neutrons .....	14
Figure 9.	Sliding Reactor Control with Tungsten and Lithium Hydride Shadow Shield .....	19
Figure 10.	GCR Fluence as a Function of Solar Cycle Minimum and Maximum.....	23
Figure 11.	Shielding Effectiveness Against GCR at Solar Minimum.....	24
Figure 12.	Operating Principle of Seebeck Effect and Thermoelectric Converter .....	27
Figure 13.	Ideal Rankine Temperature/ Entropy Diagram.....	28
Figure 14.	Example of Potassium Rankine System .....	29
Figure 15.	Ideal Brayton Temperature/Entropy Diagram .....	30
Figure 16.	Ideal Stirling Temperature/Entropy Diagram .....	31
Figure 17.	Example of Stirling Engine.....	32
Figure 18.	The Four Thermodynamic States of the Stirling Engine .....	33
Figure 19.	Overall Efficiency versus Peak Operating Temperature for Various Power Conversion Schemes .....	34
Figure 20.	Overall Specific Mass versus Electric Power of Launched and Conceptual Designs.....	34
Figure 21.	Mass Estimates versus System Power of Individual Components .....	35
Figure 22.	Liquid Droplet Radiator Concept.....	37
Figure 23.	Parameters of the PeBR concept Design .....	44
Figure 24.	Comparisons of Similar KRS.....	48
Figure 25.	Mass Breakdown of Three Competing KRS Designs.....	49
Figure 26.	Reactor Mass versus Thermal Power Output for 1-10 MWe Reactor Plants ..	56
Figure 27.	Specific Masses Comparatively.....	59
Figure 28.	Graph of Space Nuclear Power Design's Mass versus Power (log-log) .....	59
Figure 29.	Magnum Launch Vehicle as Proposed in NASA's DRM .....	71
Figure 30.	Database of Space Nuclear Power Designs, .....	78
Figure 31.	Opposition Class Trajectories .....	80
Figure 32.	Conjunction Class Trajectories .....	81
Figure 33.	Spiral Out Path of Low Thrust Trajectory .....	82
Figure 34.	Outbound Leg of Human Piloted Variable Isp Trajectory.....	82
Figure 35.	Comparison of Mission Durations and Mission Types .....	83
Figure 36.	Number of Sunspots versus Time with Sine Curve Approximation.....	84
Figure 37.	Distance Between Mars and earth with Sine Approximation.....	85
Figure 38.	Solar Weather and Distance between Mars and earth versus Time.....	86

THIS PAGE INTENTIONALLY LEFT BLANK

## LIST OF TABLES

Table 1.	Earth and Mars comparative parameters.....	1
Table 2.	SNAP-10A Characteristics .....	9
Table 3.	Candidate Ceramic Fuel Properties .....	16
Table 4.	Organ Specific Exposure Limits.....	20
Table 5.	Current Career Exposure Limits by Age and Sex*.....	20
Table 6.	Sunspot Activity versus Time of Measurement.....	22
Table 7.	GCR dose data in rem/year* .....	24
Table 8.	Solar Flare Radiation Dose* .....	25
Table 9.	Estimated Dosage for Astronauts Going to Mars .....	25
Table 10.	Mass and Power Comparisons of SP-100 Program and Scaled SP-100,.....	49
Table 11.	Temperature and Efficiency Values for KRS and CBC Conversion Systems .....	57
Table 12.	Radiator Temperature and Power per Square Meter Emitted.....	58
Table 13.	Mass Estimation of 4MWe System.....	58
Table 14.	Mars Missions Past, Present, and Future .....	69

THIS PAGE INTENTIONALLY LEFT BLANK

## **ACKNOWLEDGMENTS**

Thank you Dr. Chang-Diaz and CDR Steve Bowen for giving me the seed, Dr. Sherif Michael for the water, Andy Presby for being the seed next door, CAPT Dan Bursch and Dr Oscar Biblarz for the caretaking, and of course Laurie for your sunshine.

THIS PAGE INTENTIONALLY LEFT BLANK

# I. INTRODUCTION

## A. GENERAL

All great societies have sent explorers over the horizon to explore the new world. Queen Isabella tasked Columbus with finding the path to the Spice Islands, Thomas Jefferson tasked Lewis and Clark to explore the Louisiana Purchase, and President Kennedy challenged NASA to conduct manned exploration of the Moon. With the exciting occurrences of the past year, the landing of the Mars rovers, evidence of water on Mars, the President's Space exploration initiative, and the announcement of Naval Reactors working with NASA on building America's second space nuclear fission power source, America's space exploration future shines brightly. Part of President Bush's exploration vision for NASA is manned exploration of Mars. This paper will explore the optimal power systems to get us there, define a specific mass for the power system, and end with recommendations to decision makers on where to invest today to make it a reality.

## B. BACKGROUND

### 1. Mars

Mars, the fourth planet from the sun, was named for the Roman god of war because of its red color. With a distance from earth between 56-399 million kilometers, Mars rotates around the sun in about the twice the time earth does. A Martian day is similar in length of the earth and the land mass of mars equals the land mass of the earth.

Parameter	Earth	Mars
Bulk density(kg/m <sup>3</sup> )	5520	3933
Equatorial Gravity (m/s <sup>2</sup> )	9.81	3.71
Eccentricity	0.0167	0.0934
Day length (hours)	24	24.66
Mass (kg)	$5.98 \times 10^{24}$	$6.42 \times 10^{23}$

Table 1. Earth and Mars comparative parameters<sup>1</sup>

---

<sup>1</sup> Wiley J. Larsen and Linda Prane eds, *Human Spaceflight, Mission Analysis and Design* (San Francisco: McGraw Hill Companies, Inc) 78, 79, 89.

Because Mars seems to have at one time had liquid water on its surface and it is within reasonable reach of earth, Mars should be the next planet explored by humans. Data on all Mars missions to date are included in the Appendix.

### **C. MARS EXPLORATION TIMELINE AND OBJECTIVES**

The objectives of each phase of the Mars exploration mission differ. The first phase successfully began with the Mariner 9 program on November 14, 1971.<sup>2</sup> Mariner 9 led the way for the Viking landers in the mid seventies. Currently, the first phase continues with the Mars Exploration Rovers (MER) Spirit and Opportunity exploring the red planet. The following three sections outline the three phases of the Mars exploration mission.

#### **1. Initial Unmanned Missions**

The exploration of any foreign land begins with a survey of the area to find where to begin. Mars exploration began with an imaging mission, then with landers and relay satellites. More recently more imagers and remote sensing satellites have been sent to Mars, and at the beginning of the year the MERs successfully landed and have sent back immense amounts of data, including conclusive evidence Mars once harbored liquid water.<sup>3</sup>

Beginning in 2011 NASA will begin sending human precursor missions to Mars in order to prove technologies and prepare the landing space integral to a safe first manned mission. Some of the technologies which will be proved include: orbital rendezvous and docking, precision landing, resource extraction and utilization, and optical communications.<sup>4</sup> The timeline for sending human to Mars will be based upon the successes and knowledge gained by these missions.

#### **2. First Manned Missions**

The first manned mission to Mars should be a short stay mission. Mission durations and astrodynamics are covered in the appendix. The objectives of the first

---

<sup>2</sup>Wikipedia, *Mariner 9*, [http://en.wikipedia.org/wiki/Mariner\\_9](http://en.wikipedia.org/wiki/Mariner_9) (accessed November 22, 2004).

<sup>3</sup>Jet Propulsion Laboratory, *Mars Rovers Probing Water History at Two Sites*, <http://www.jpl.nasa.gov/news/news.cfm?release=2004-253> (accessed November 22, 2004).

<sup>4</sup>NASA, *The Vision for Space Exploration* [http://www.nasa.gov/pdf/55583main\\_vision\\_space\\_exploration2.pdf](http://www.nasa.gov/pdf/55583main_vision_space_exploration2.pdf), 9 (accessed November 22, 2004).

manned mission should be to validate the information gathered by the previous unmanned missions as well as begin to establish a human presence on Mars. The first manned mission should also validate our assumptions about long duration space travel beyond the earth's gravity well. An estimated timeframe for the first mission is 2030.

### **3. Follow-on Manned Missions**

Follow on manned missions will be similar to the research conducted at the Antarctic Research Facility or the continued manned presence at the International Space Station. The system which gets the astronauts to the Mars Research Facility should be reusable and be able to minimize transit times. By minimizing transit times radiation exposure durations are reduced and zero gravity (if artificial gravity is not implemented) ramifications are minimized. Follow on missions should build upon the first mission and include longer duration stays on the surface, typical of conjunction trajectories. The timing and trajectory options are presented in the appendix.

## **D. SPACE NUCLEAR POWER**

The primary enabling technology for a manned mission to Mars is nuclear power. Nuclear power for space application is not a new idea, and there are currently one US and thirty-three Russian fission reactors in space.<sup>5</sup> None are presently operational.

---

<sup>5</sup>Uranium Information Center, <http://www.uic.com.au/nip82.htm> (accessed November 22, 2004).

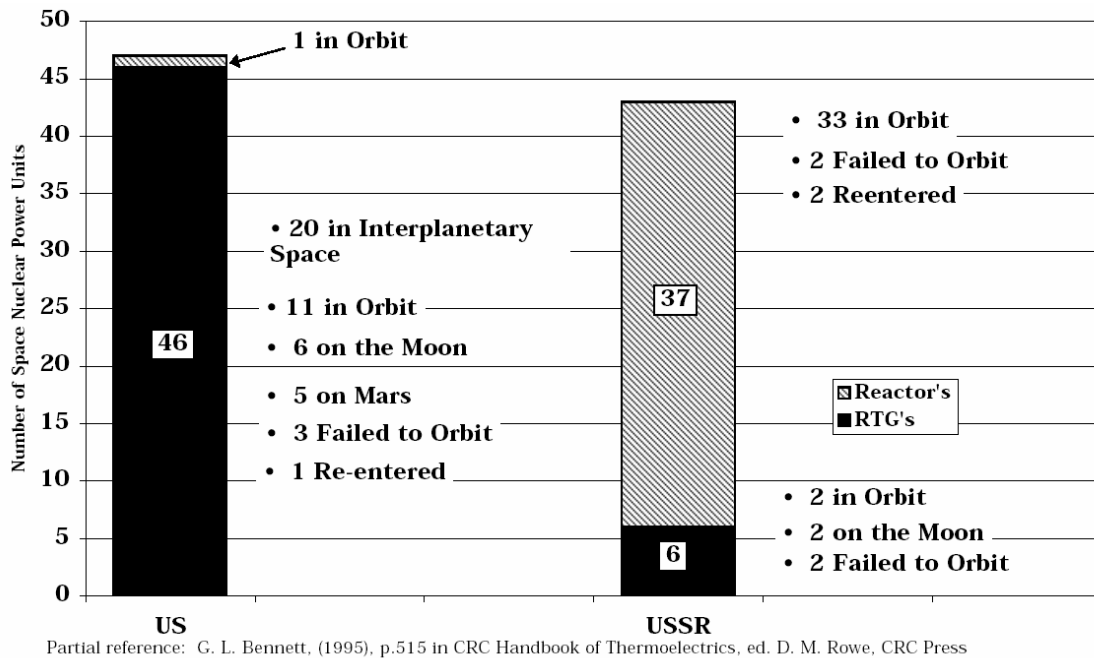

Figure 1. RTGs and Reactors currently in Space

A manned mission to Mars is possible without nuclear power. Using chemical propulsion severely limits the payload capable of going to Mars, extends the transit times, and removes safe abort scenarios for the mission. This reduces safety, increases risk, and limits mission capabilities. Using electric propulsion (EP) provides large propellant mass savings over chemical due to EP's high specific impulse, adds flexibility to the mission, and increases safety. EP requires a power rich power source. Nuclear power provides this power rich source, enabling a high payload mass fraction, which will allow more flexibility in redundancy and safety. Space nuclear power systems provide the durability, longevity, and ruggedness necessary for space exploration beyond earth's gravity. The following two figures are the most succinct means of portraying the necessity and validity of fission power for manned exploration beyond the moon.

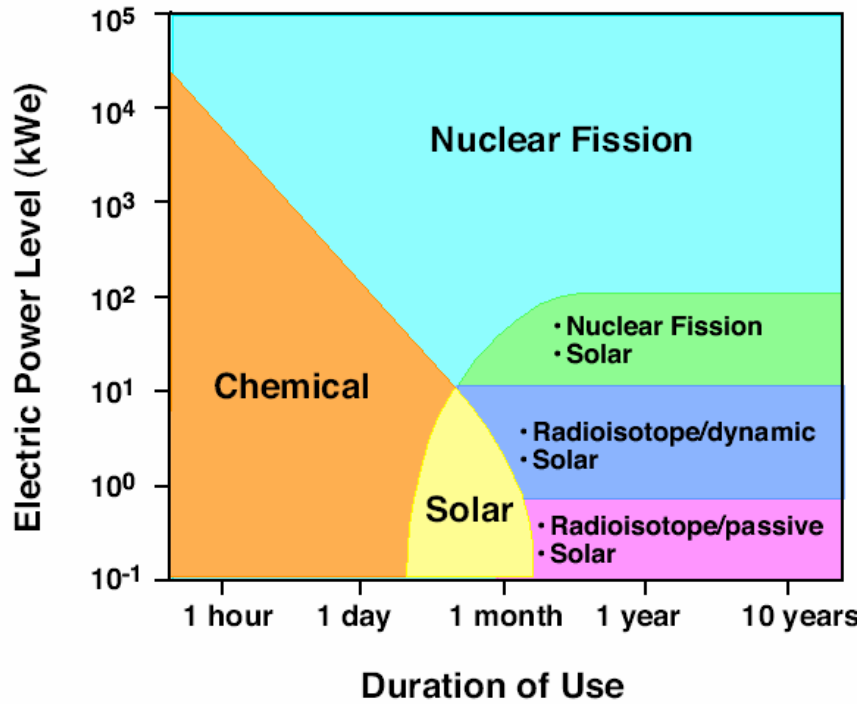

Figure 2. Space Vehicle Electric Power Requirement versus Duration of Mission Use<sup>6</sup>

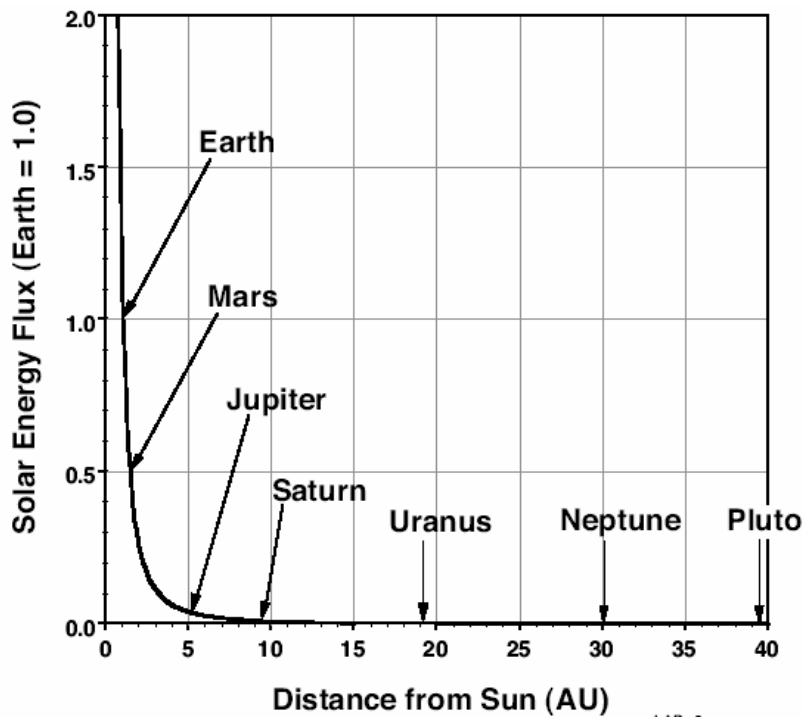

Figure 3. Solar Energy Flux Available versus Actual Distance from the Sun<sup>7</sup>

<sup>6</sup> Leonard Dudinski, Space Technology and Applications International Forum (STAIF), short course notes, Albuquerque, NM, February 2004.

Working on the assumption that the transit time to Mars will be around a six months and the stay on Mars no less than three, the duration of the total round trip is minimally a year and three months. If a second assumption is made that the power requirement for the mission will be above 100kWe, then the first figure shows that the power sources available for such a long duration mission at this power level is either nuclear fission or possibly solar. In figure 3, the solar flux available as a function of the distance from the sun shows that the flux from the sun drops off to less than half of its earth flux near the Mars orbit. The solar array necessary for propulsion and power becomes impracticable and unwieldy. For power systems greater than 30kWe, nuclear power provides a more compact and durable power source over solar.<sup>8</sup> Therefore, for a manned mission to Mars nuclear power is the most viable option.

Nuclear power can be broken in to two types: Radioisotope Thermoelectric generators (RTGs) and fission sources. RTGs rely on the long stable half life of plutonium-238. As plutonium decays it gives off heat. That heat is converted to electrical power by thermionics which are about five percent efficient. The rest of the heat is radiated to space by the RTG's radiator fins. RTGs powered experiments on the moon in the Apollo program, Galileo, Cassini, and Voyager. Specific power of RTGs is in the range of 4.5-10We/kg.<sup>9</sup> Because of this low specific power, RTGs realistic power output falls below the 1kWe range. Manned exploration vehicles begin in the low MWe range. Because of the high power requirement, duration of use, and distance from the sun, nuclear fission is the only power source for manned exploration vehicles in Mar's orbit. Two primary methods exist in which to extract the fissions' energy for the use of power and propulsion. One is called Nuclear Thermal Propulsion (NTP) and the other is Nuclear Electric Propulsion (NEP).

---

<sup>7</sup>Leonard Dudinski, STAIF, short course notes, Albuquerque, NM, February 2004.

<sup>8</sup>NASA, SP-100 Power Source, <http://spacelink.nasa.gov/NASA/Projects/Human.Exploration.and.Development.of.Space/Human.Space.Flight/Shuttle/Shuttle.Missions/Flight.031.STS-34/Galileos.Power.Supply/SP-100.Power.Source> (accessed November 22, 2004)

<sup>9</sup>Mohammed El-Genk, "Energy Conversion Technologies for Advance Radioisotope and Nuclear Reactor Power Systems for Future Planetary Exploration", *21<sup>st</sup> International Conference on Thermoelectronics*, 2002,1.

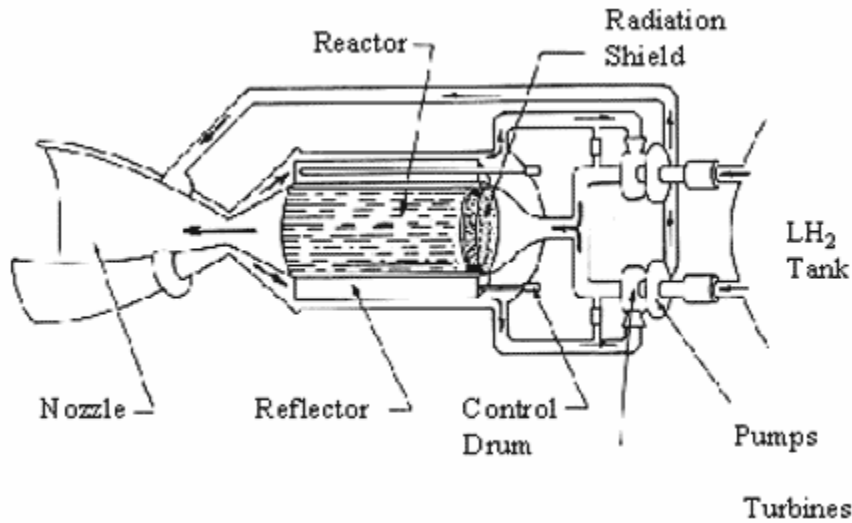

Figure 4. Generic Nuclear Thermal Rocket

NTP is currently the design of choice for the NASA Mars Design Reference Mission version 3. NTP uses the reactor as the heat source for the rocket to produce thrust. As seen in the above figure, the reactor coolant, typically hydrogen, flows from the storage tank to the nozzle, to regeneratively cool the nozzle and preheat the coolant. The hydrogen then flows through the reactor, where it then is heated to approximately 2700K and expelled through the convergent, divergent nozzle as the rocket propellant. This concept dates back to the 1960s where the KIWI and NERVA programs successfully tested the concept. Among NTP's advantages are a high specific impulse (around 900s) as compared to chemical, actual tested hardware, high thrust, and a simple design with minimal moving parts. Among its disadvantages are high fuel temperatures, no flown hardware, and its limited abort scenarios in a Mars mission.

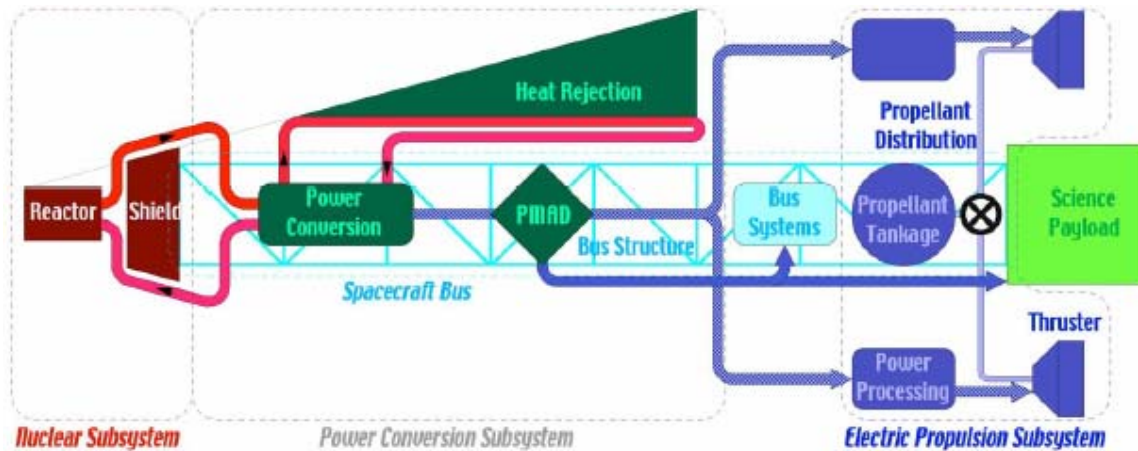

Figure 5. Generic Nuclear Electric Vehicle<sup>10</sup>

NEP uses the same fissioning process of NTP differently. There are many options for each of the subsystems shown in the above figure. The nuclear subsystem is composed of the reactor, its coolant, and the shield. Typically of a monocoque shape, the shield reduces the neutron and gamma flux for the supporting machinery and payload. The power conversion subsystem takes the heat generated by the reactor and converts it to electricity, rejecting the unusable heat via radiation in the heat rejection subsystem. Power Management and Distribution (PMAD) subsystem distributes the electrical power to the electric propulsion and payload.

Nuclear electric propulsion has the following advantages:

- Flexibility in design
- Flight proven hardware

And the following disadvantages:

- Complexity of design
- Size of the heat rejection subsystem

Another advantage of NEP is the amount of money, time, and research which has been done on various designs.

<sup>10</sup> Leonard Dudinski, STAIF, short course notes, Albuquerque, NM, February 2004.

## 1. SNAP-10A

The United States' only launched space reactor was SNAP-10A. It was a nuclear electric satellite (electric propulsion was not used then) used as a demonstration platform. Forty-three days after launch SNAP-10A shutdown due to a voltage regulator failure on the host vehicle.

SNAP-10A Characteristics.	
Date Launched	3-Apr-65
Planned/Actual Lifetime	1yr/43 days (due to VR failure on host S/C)
Pe	533We
Reactor Outlet Temperature	827K
Mass	436kg
Radiator area	5.8m <sup>2</sup>
Specific mass	818 kg/kWe

Table 2. SNAP-10A Characteristics<sup>11</sup>

## 2. SP-100

SP-100 was a NASA-JPL, DoD, and DOE sponsored program intended to develop a power system which could provide 100kWe consistently for ten years. SP-100 was a fast spectrum, uranium nitride (UN) fueled, lithium cooled reactor with a Silicon/Germanium thermoelectric power conversion system, and potassium heat pipe radiators. The reactors operating temperature was 1350K allowing for the use of less exotic materials. The shadow shield was composed of lithium hydride for neutrons and tungsten for gamma shielding. A boom was also used in conjunction with the shield to accommodate the payload's radiation tolerances.<sup>12</sup>

SP-100 was started in 1983 and the preliminary design, as discussed above, was chosen in 1985. Phase II of the program was ground system testing. Phase II went through 1993, when the program was terminated due to lack of funding. General Electric was the prime contractor and the program's total funding was \$415.2million. With 220

---

<sup>11</sup> Joseph A. Angelo, Jr. and David Buden, *Space Nuclear Power*, (Malabar, Florida: Orbit, 1985), 167.

<sup>12</sup>NASA, *SP-100 Power Source*, <http://spacelink.nasa.gov/NASA.Projects/Human.Exploration.and.Development.of.Space/Human.Space.Flight/Shuttle/Shuttle.Missions/Flight.031.STS-34/Galileos.Power.Supply/SP-100.Power.Source>. (accessed November 22, 2004)

industry workers and 80 national lab and NASA employees, SP-100 research and testing is the armature upon which most of today's space nuclear technology rests.<sup>13</sup>

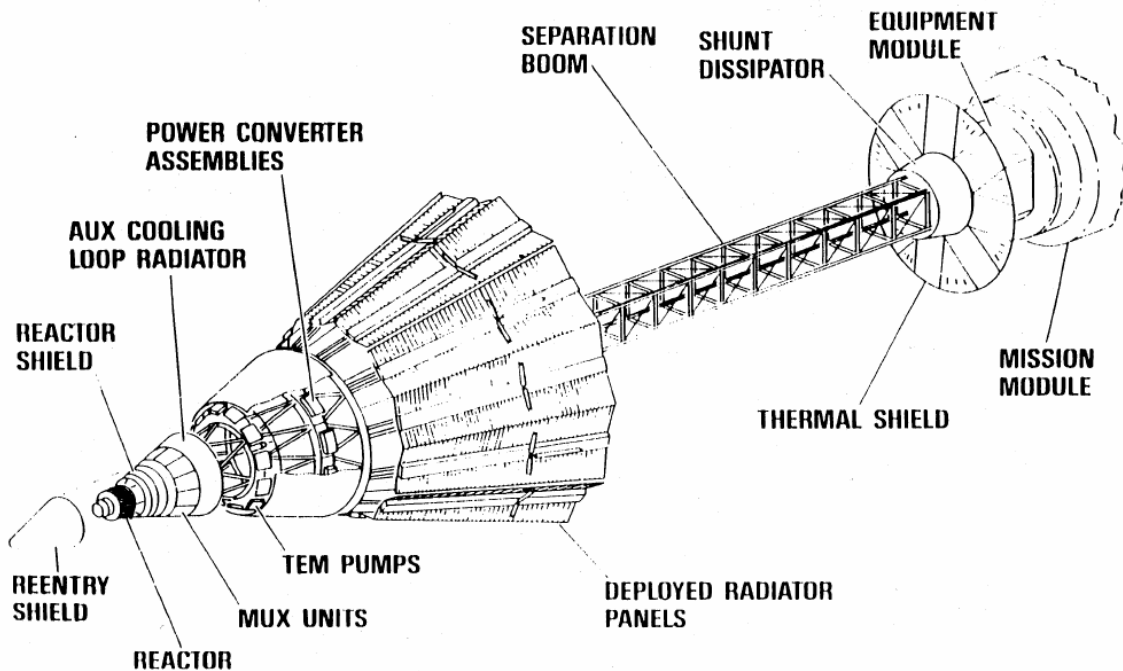

Figure 6. SP-100 Design Layout

## E. SPECIFIC POWER, SPECIFIC MASS

Power systems have two separate energy conversions: the conversion of stored energy to available energy and the available energy into propulsive power.

### 1. Stored to Available

For a chemical rocket, the maximum energy available per unit mass of propellant is the heat of the combustion reaction  $Q_R$ . The chemical power available is defined as

$P_{CHEM} = \dot{m} Q_R J$ , where  $J$  is a conversion constant and  $\dot{m}$  is the mass flow rate of the propellant. Chemical power multiplied by the combustion efficiency defines the available power.<sup>14</sup> Typical combustion efficiencies range between 94 and 99%. In electrical propulsion systems, the power available is the power source power, either solar or thermal power from fission, multiplied by the power conversion efficiency. (Deep

<sup>13</sup> University of Wisconsin Madison, Space Nuclear Power Sources, <http://fti.neep.wisc.edu/neep602/SPRING00/lecture20.pdf>. (accessed November 22, 2004)

<sup>14</sup>George Sutton and Oscar Biblarz, Rocket Propulsion Elements, (New York: Wiley, 2001) 36.

Space 1 utilized solar panels with a conversion efficiency of 22.5%).<sup>15</sup> From stored to available power for propulsion, chemical rockets are more efficient.

## 2. Available to Propulsive Power

Jet power is defined as:  $P_{jet} = \frac{1}{2} \dot{m} v^2 = \frac{1}{2} F g_o I_s$  or the time rate of change of the expended kinetic energy used to propel the vehicle. It is a function of both the force and the specific impulse of the engine. Specific power is defined as the jet power divided by the mass of the propulsion system. Because electric propulsion systems carry a large, massive power source relative to the chemical rocket, their specific powers are much lower than chemical rockets.

By comparing efficiencies and propulsive power, each propulsion system can be better matched to a mission objective. The specific power of the electric propulsion system is lower than the chemical, yet the power source is virtually unlimited versus the fuel expenditure of chemical systems. The high exhaust velocities of electric propulsion also make electric propulsion more “fuel efficient”. Therefore, with an unlimited power source and high fuel efficiencies, electric propulsion matches well with long duration (greater than one year) space flight.

Now that electrical propulsion has been shown to be more suited for long duration space exploration missions and nuclear power has been shown to be more suited as the power source for electric propulsion, the thesis will compare and try to predict the specific mass of various power systems. Specific mass is defined as the mass of the power system in kilograms required to produce one kilowatt of electric power to the payload and propulsion system. The mass includes all power system components from the payload side of the truss structure (as seen in the SP-100 diagram) out to the reactor. The lower the specific mass, the less mass placed in low earth orbit (LEO). Since initial mass in low earth orbit (IMLEO) equates to money, roughly \$10000/kg, the lower the IMLEO the lower the launch costs. The power system is considered more mass efficient the higher the specific mass. Also, with a lower overall mass for a given power system,

---

<sup>15</sup>Jet Propulsion Laboratory, *DS-1 Primary Mission*, [http://nmp.jpl.nasa.gov/ds1/DS1\\_Primary\\_Mission.pdf](http://nmp.jpl.nasa.gov/ds1/DS1_Primary_Mission.pdf) (accessed November 22, 2004)

the lower the inertia required to move the object. Specific power aids in mission planning and launch vehicle requirements generation.

The figure below shows the specific mass of flown systems such as SNAP-10A and the Russian TOPAZ. Also of note is the lowering of specific mass as the power level increases. This graph also shows the upward scalability of Brayton and Rankine cycles, predicting that higher power NEP systems will use one or the other for power conversion.

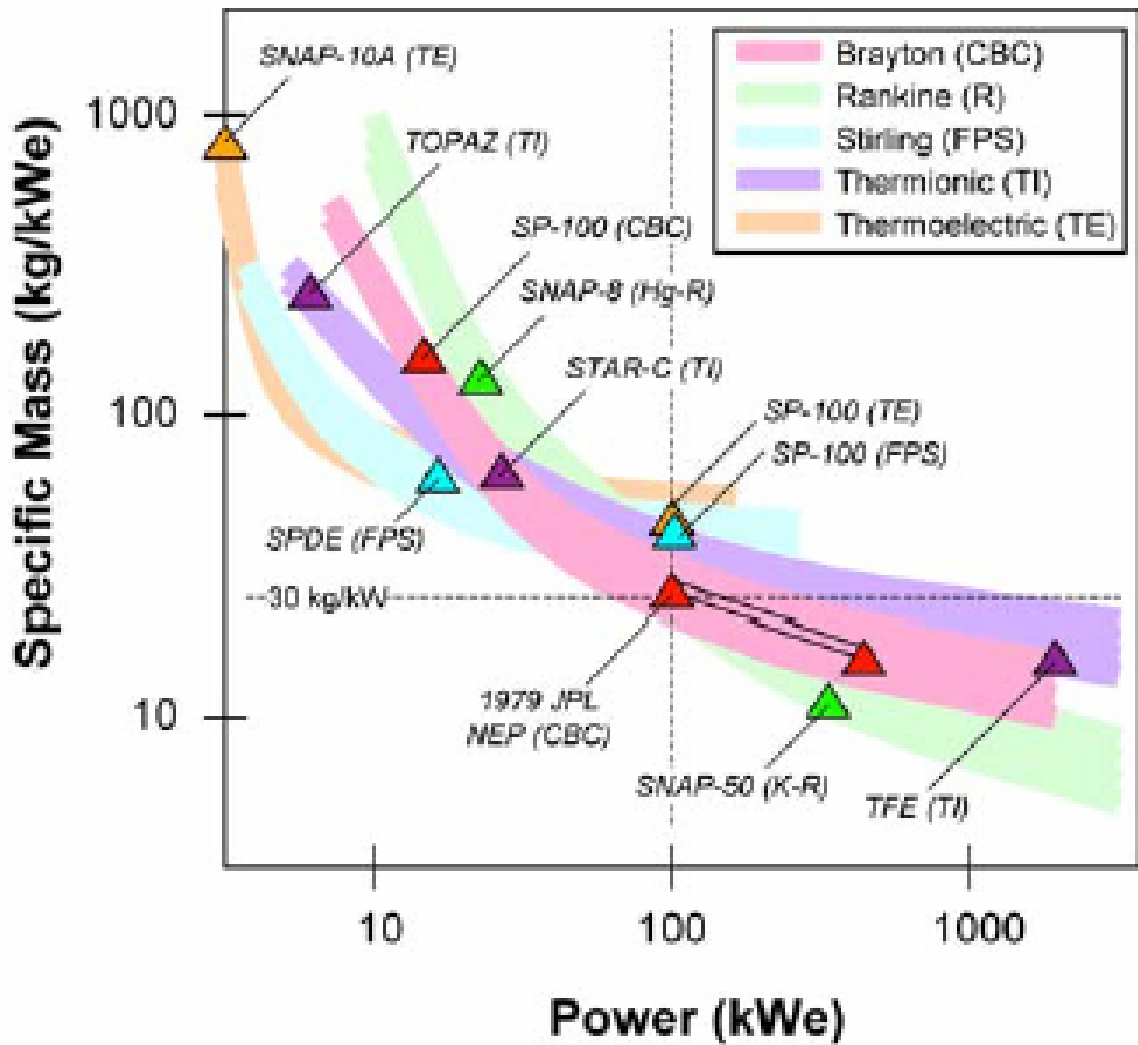

Figure 7. Overall Specific Mass versus Electric Power Output of Launched and Conceptual Designs<sup>16</sup>

<sup>16</sup> Lee Mason, STAIF, short course notes, Albuquerque, NM, February 2004.

## II. SPACE POWER SYSTEM COMPONENT OPTIONS

Perhaps the most difficult task for the conscientious designer is the exercise of proper technical judgment in extrapolating from current to future technology. Almost any propulsion scheme can be made to appear feasible (and even attractive) if the engineering assumptions are sufficiently broad. This is often the case with new concepts where the physics or engineering definition required to perform a more thorough analysis may legitimately be unknown. In such instances it is always prudent to err on the conservative side when performing system assessments. Overly optimistic assumptions (while perhaps making the initial concept more attractive) are frequently not borne out in practice and inevitably foster significant technical and programmatic repercussions. Even with relative technological risks factored in, a concept that relies on liberal assumptions can be made to appear substantially more attractive than competing designs using more conservative assumptions, which can lead to the unwise disbursement of program funds, the stagnation of promising areas of research, or other unfortunate outcomes.<sup>17</sup>

### A. NUCLEAR SUBSYSTEMS

Many different types of space nuclear power systems exist; however, common among fast fission nuclear electric systems are the reactor, composed of fuel, coolant, reflector, and control system, and the shield.

#### 1. Reactor

##### *a. Fast versus Thermal*

Power, volume, and mass requirements drive the type of reactor used for space applications. With a stated power requirement, reduction of the mass and volume which meets this power requirement becomes paramount. Reactor size drives shield size, which is the largest component of the nuclear subsystem in terms of mass. Different types of reactors require different types of fuel, moderation, and shielding.

Fissions can occur at two levels of neutron energy. For U235 neutron energies at 0.25eV and 1.0MeV cause the most fissions. This probability of fission is defined as the fuels' microscopic cross section of absorption. Therefore, we design a reactor to utilize neutrons at these energy levels. Thermal reactors rely on the lower

---

<sup>17</sup> AIAA SP-108-2004, "Recommended Design Practices for Conceptual Nuclear Fusion Space Propulsion Systems" 4.

energy neutrons and fast reactors on the higher energy neutrons.<sup>18</sup> The fission neutron energy spectrum has been empirically derived as the function

$$N(E) = 0.453 * e^{-(E/0.965)} \sinh * \sqrt{2.29 * E} \quad 19$$

where N(E) is the fraction of neutrons emitted per fission with energy E(MeV) per unit energy range. Figure 8 shows the graph of this function. As can be seen in figure 8, most of the neutrons produced are at the 0.75MeV energy level; therefore, for a thermal reactor, these fast neutrons must be slowed down to interact with the uranium. To slow down neutrons, a moderator is used. Typically, a moderator is composed of hydrogen in some form, because hydrogen's atomic weight is equal to that of the neutrons it is slowing down. Moderators tend to be heavy and voluminous and not suitable for space applications.

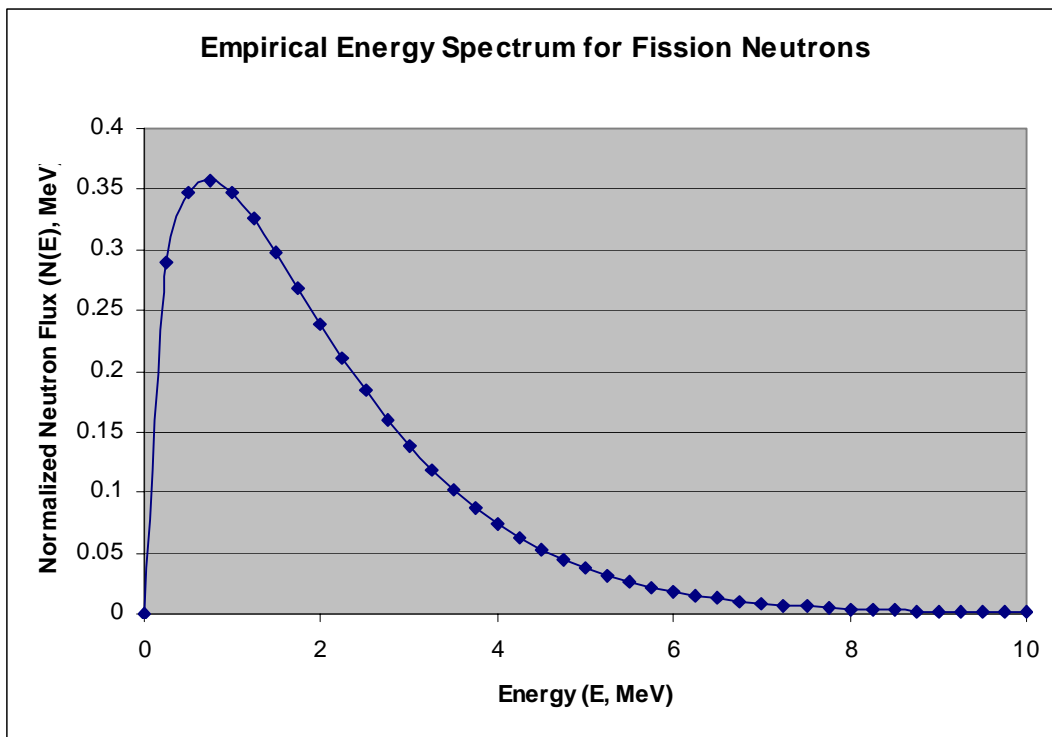

Figure 8. Empirical Energy Spectrum for Fission Neutrons

<sup>18</sup> Ronald W. Humble, Gary N Henry, and Wiley J. Larson, Space Propulsion Analysis and Design, (San Francisco: McGraw Hill, 1995) 476.

<sup>19</sup> Richard Stephenson, Introduction to Nuclear Engineering, (New York: McGraw-Hill, 1958) 59.

In addition to not requiring a moderator, fast reactors are also advantageous to space applications because they have high power densities, are compact, and buildup less fission product poisons (Xe and Sm) than do thermal reactors.<sup>20</sup> The fast reactor satisfies the power requirement while providing the most compact reactor possible.

**b. Fuels**

Many fuel options are available for space reactors. Pu-239, and U-235 are the usual candidates, and each have been extensively studied and tested to varying degrees. Plutonium has the most compact form and has been used as the primary fuel for RTGs since the beginning of the space age. However, their compact fuel form comes at a cost of an exceptionally high Curie content. In smaller power systems, such as RTGs, the curie content is acceptable and the risk can be mitigated by a containment shield which has been proven successful in the failed launch of both SNAP-19B1 and SNAP-27.<sup>21</sup> In higher power systems, greater than 100kWe, the mass savings of using plutonium is counter acted by the mass increase of the safety features required to contain the radioactivity of the fuel should there be a launch failure. In the current nuclear space reactor development project Prometheus, safety is described as the primary operating principle governing the design.<sup>22</sup> Therefore, plutonium will not be considered for future space reactor systems.

Uranium has long been the nuclear fuel of choice for land and sea reactor power systems. The three major space reactors (SNAP-10A, RORSAT (Russian), TOPAZ (Russian)) have used uranium-zirconium-hydride, uranium-molybdenum, and uranium dioxide respectively.<sup>23</sup> Uranium-235 is the fissile isotope utilized in these fuels. Because only 0.7204% of naturally occurring uranium is 235, uranium must either be enriched or moderated for thermal reactors to maintain a self sustaining fission.<sup>24</sup> Most

---

<sup>20</sup> Mohammed El Genk, STAIF, short course notes, Albuquerque NM, February 2004.

<sup>21</sup> Joseph Angelo and David Buden, Space Nuclear Power, (Malabar, Florida: Orbit Book Company 1985) 134.

<sup>22</sup> NASA, *Project Prometheus*, <http://exploration.nasa.gov/programs/prometheus.html>, (accessed October 1, 2004)

<sup>23</sup>SpaceWorks Engineering Inc, *Advanced Concepts Database*, <http://sei2.sei.aero/ACDB/ACpowDB.asp>, (accessed November 22, 2004)

<sup>24</sup>Jefferson Lab, *Uranium*, <http://education.jlab.org/itselemental/ele092.html> (accessed November 22, 2004)

space reactors utilize at least 90% enrichment or greater to lower the fuel mass necessary for required power operations.

There are a number of fuel requirements, among which the major concerns are temperature constraints, reactivity with cladding, and capability to contain fission products. In order to operate at efficient temperatures in the reactor, uranium must be in alloy form. The candidate uranium fuels, also known as ceramic fuels, which meet these requirements are uranium carbide (UC), uranium nitride (UN), and uranium dioxide (UO<sub>2</sub>). As a reference pure uranium has a melting point of 1408K.<sup>25</sup>

Property	UO <sub>2</sub>	UC	UN
Density (kg/m <sup>3</sup> )	9600	13600	13600
Thermal conductivity (W/mK at 1273K)	2.5	23	24
Melting point (K)	3023+/-40	2673+/-100	3123+/-30

Table 3. Candidate Ceramic Fuel Properties<sup>26</sup>

Uranium oxide has the most empirical data gathered of the three fuels, but its density and thermal conductivity are much lower than that of uranium carbide or uranium nitride. The lower density implies the volume of the core would have to be larger than if the other two fuels were used. Uranium carbide has better thermal conductivity and density than uranium oxide, but produces a high amount of fission product gases, swells excessively, and has difficult chemistry control.<sup>27</sup> Uranium nitride has a high fuel density, high thermal conductivity, and a high melting point. Some cladding interaction issues exist, but have been mitigated during the SP-100 program research. UN can currently be produced by BWX Technologies.

UN, in fuel pin form, consists of fuel pellets, clad with the refractory metal Nb-1Zr and an inner sheath of rhenium. Niobium alloys have the following advantages:

<sup>25</sup>Jefferson Lab, *Uranium*, <http://education.jlab.org/itselemental/ele092.html> (accessed November 22, 2004)

<sup>26</sup> Mohammed El Genk, STAIF, short course notes, Albuquerque, NM, February 2004

<sup>27</sup>W. J. Carmack, D.L.Husser, T.C.Mohr, and W.C.Richardson, "Status of Fuels Development and Manufacturing for Space Nuclear Reactors at BWX Technologies", STAIF, Albuquerque, NM, February 2004, 426.

- Easy fabricability
- High ductility
- High melting temperature
- Low ductile to brittle transition temperature
- Low density

One percent zirconium is used to tie up the free containment oxygen found in niobium alloy and to boost niobium's creep strength. Oxygen and carbon impurities potentially cause interactions with the fuel which could change the uranium to nitride ratio, reducing the stable properties of the fuel form. Any free uranium in the fuel form will succumb to uranium's lower melting temperature. Also as oxygen reacts with the lithium coolant, it forms lithium oxide which could precipitate out and clog coolant channels or piping. In the 1960s PWC, a carbide form of Nb-1Zr was shown to have superior creep strength over Nb-1Zr, but these results could not be replicated in commercial production.<sup>28</sup>

A rhenium sheath is welded to the inside of the Nb-1Zr in order to provide a barrier between the UN fuel which is reactive with the niobium. A benefit to the rhenium is that it has a low cross section of absorption in the fast spectrum, yet it also has a high cross section of absorption in the thermal neutron spectrum. These properties are favorable for a fast reactor due to the fact that they mitigate the reactivity in a water submersion accident. For note, a water submersion accident causes the reactor to be surrounded by (or even penetrated by) water which is an excellent thermalizer of fast neutrons. The thermalization could cause an inadvertent criticality or nuclear accident.

Because of its low swelling and fission gas release, its high melting point, and favorable thermal characteristics, UN is the fuel of choice for future space reactors. Along with Nb-1Zr cladding and a rhenium liner, this fuel cladding combination allows for a safe, reliable, and feasible space power system.

### *c. Reactivity Control*

A small amount of neutrons (approximately 1.730 percent in U235 fast fission<sup>29</sup>) are released shortly after the fission has occurred. These delayed neutrons are produced by the fission product nuclei decay and not the fission itself. These neutrons

<sup>28</sup> P.J. Ring and E.D. Sayre, Material Requirements, Selection and Development for the Proposed JIMO Space Power System, STAIF-2004, 809.

<sup>29</sup> Richard Stephenson, Introduction to Nuclear Engineering, (New York: McGraw-Hill, 1958), 61.

are of significant importance because they allow the reactor to be controlled. Each fission of U235 gives off 2.46 neutrons. If only one of these neutrons continues on and causes another fission, then the process is self sustaining. The ratio of the number of neutrons produced in one generation to the next is called the multiplication factor, or  $k$ . If  $k$  is less than one, the reaction is not self sustaining. If it is greater than one then the power level is increasing. A goal of one is achievable with a reactivity control system.

For a reactor of finite size the reactivity is defined by the effective multiplication factor (multiplication factor corrected for neutron loss mechanisms).

$$\delta k = \frac{(k_{eff} - 1)}{k_{eff}} \text{ }^{30}$$

Similar to the multiplication factor, if the reactor is sub critical the reactivity is negative. If the reactor is supercritical then the reactivity is positive. By controlling the reactivity we control the number of fissions occurring and thus the energy output of the reactor.

Reactivity control in ground based systems is typically done with control rods and burnable poisons. Both control rods and burnable poisons are materials, such as hafnium or boron, which have a high cross section of absorption for neutrons. By removing the neutrons with materials other than uranium, the numbers of neutrons available for fission goes down. The control rods can also be programmed to negate the effects of changing neutron flux distributions which occur over time. Plus, burnable poisons can absorb neutrons from a given period of time helping to flatten the core flux distribution. For space reactors, which typically have a shorter operating life (7yrs as opposed to decades for terrestrial plants) and use fast neutron flux, which is not susceptible to absorption from fission product poisons, reactivity control techniques usually exploit reactor drums or shutters/windows.

---

<sup>30</sup>Richard Stephenson, Introduction to Nuclear Engineering, (New York: McGraw-Hill, 1958) 319.

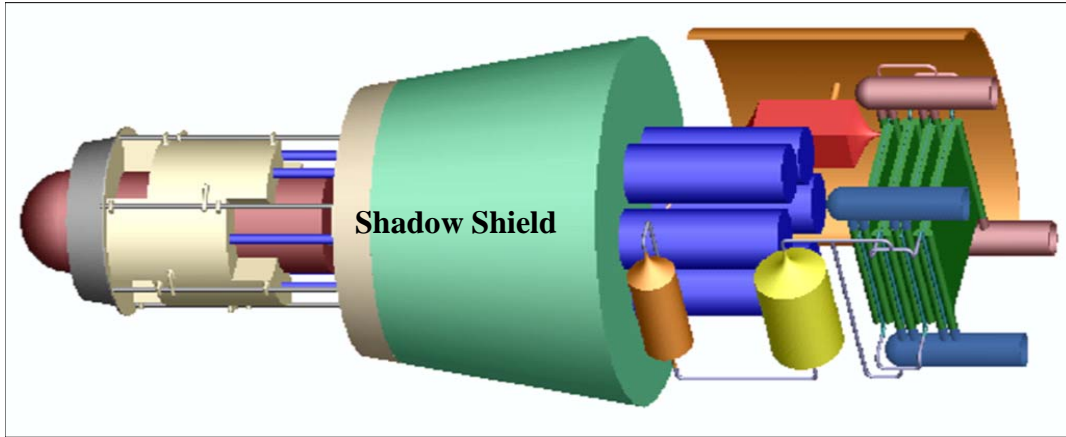

Figure 9. Sliding Reactor Control with Tungsten and Lithium Hydride Shadow Shield<sup>31</sup>

Reactor control drums typically surround the outside of the reactor. They usually have a neutron poison on one side ( $B_4C$ ) and a reflector material (beryllium) on the other. The drums spin to show one side or the other, or a combination of both. Without the reflectors on most space reactors the core cannot become critical. In larger cores, such as those in the MWe range, control rods are also used to provide enough negative reactivity to be able to shutdown the reactor in a water submersion accident. Control rods can also slide up and down in order to flatten out the neutron flux within the core to evenly burn the fuel.

## 2. Shielding

The reactor produces a spectrum of gamma and neutron radiation which is harmful to both machinery and humans. For space applications, the radiation produced from the reactor must be mitigated by the most mass efficient means possible. In terrestrial reactors, lead and water are employed to shield equipment and personnel from gammas and neutrons. For a space reactor the shielding is typically in the form of a shadow shield. A shadow shield places the shield as close to the reactor as possible to minimize the amount of shielding necessary as well as provide the largest amount of shielding per unit mass. All electronics and payload are situated behind the shadow shield.

<sup>31</sup>Alan Newhouse, Presentation on Project Prometheus, STAIF, Albuquerque, NM, February 2004.

The shield also performs the following functions:

- Serves as structural member between the reactor and spacecraft
- Protects the inner shielding material from physical damage
- Provides structure for drive motors to reactor control elements
- Can serve as attachment for a safety reentry aeroshell<sup>32</sup>

The typically accepted maximum fluence at the payload is derived from the SP-100 study. The shield must limit the neutron fluence to  $10^{13}$  neutrons per square centimeter and the gamma dose to  $5 \cdot 10^5$  rads at the payload interface 22.5 meters from the reactor side of the shield.<sup>33</sup> These levels are not sufficient to meet the exposure limits for astronauts as set forth by NASA. Therefore, the boom must be lengthened and/or the shield /must be larger.

Exposure interval	Depth (5cm)	Eye	Skin (0.01cm)
30 Days	25 REM	100 REM	150 REM
Annual	50 REM	200 REM	300 REM
Career	100-400 (REM)	400 REM	600 REM

Table 4. Organ Specific Exposure Limits<sup>34</sup>

SEX	AGE			
	25	35	45	55
MALE	125 REM	250 REM	325 REM	400 REM
FEMALE	100 REM	175 REM	250 REM	300 REM

Table 5. Current Career Exposure Limits by Age and Sex\*

*\*The career depth equivalent dose limits is based upon a maximum 3% lifetime excess risk of cancer mortality. The total equivalent dose yielding this risk depends on sex and age at the start of exposure. The career equivalent dose limit is approximately equal to*

$$200 + 7.5 \cdot (\text{age} - 30) \text{ rem for males up to 400 rem maximum}$$

$$20 + 7.5 \cdot (\text{age} - 38) \text{ rem for females up to 400 rem maximum}^{35}$$

<sup>32</sup>Thomas A. Berg and Richard K. Disney, "Engineering and Fabrication Considerations for Cost Effective Space Reactor Shield Development", STAIF-2004.

<sup>33</sup> SP-100 Project Integration Meeting Notes, General Electric, Long Beach, CA July 19-21, 1988.

<sup>34</sup> Johnson Space Center, <http://srag-nt.jsc.nasa.gov/RadDocs/TM104782/techmemo.htm> (accessed November 22, 2004).

<sup>35</sup> Johnson Space Center, <http://srag-nt.jsc.nasa.gov/RadDocs/TM104782/techmemo.htm> (accessed November 22, 2004).

*a. Shield Design Example*

Tables 4 and 5 show the astronauts' exposure limits. Because the SP-100 fluence goals are not sufficient to maintain the astronauts outside of these limits, let's try to increase the boom and then see how much shielding on the payload side will be required. To find the gamma dose at a longer boom, the dose at 22.5m must be brought back to the source (the reactor side of the shield), and since gamma falls off as one over radius squared, the value is proportional the square of the distances. The following shows the simple calculation:

$$5 * 10^5 \text{ rads} * 22.5^2 \text{ m}^2 = 2.53 * 10^8 \text{ rads} / \text{m}^2$$
$$\frac{2.53 * 10^8 \text{ rads} / \text{m}^2}{45^2 \text{ m}^2} = 1.25 * 10^5 \text{ rads}$$

This dose is over the 7.3 year lifetime of the power system (again a SP-100 design life). Therefore, the yearly dose would be  $1.79 * 10^4$  rads. To get this into rem, we must multiply by a quality factor. This gamma energy level is 1MeV; therefore, its quality factor is 11.<sup>36</sup> The amount of rem delivered by the source is simply the dose in rad multiplied by the quality factor or  $1.96 * 10^5$  rem. As seen in table 4, the most restrictive yearly dose allowable is 50rem. To get the actual dose down to less than the acceptable dose, we must shield the habitability module (or it would not be habitable) with lead or an equivalent material for gamma. Assuming lead with a tenth thickness (the amount of material required to reduce the flux by a factor of ten) is 2 inches, then it would require four tenth thicknesses to shield to under the allowable dose. This means a shield of lead eight inches thick must be placed between the astronauts and the reactor forty-five meters away. A similar set of rudimentary calculations can be done for neutrons. This paper does not optimize the combination of boom length and shield thickness, but uses the above as a demonstration of how this would be done. Many factors such as the boom mass versus shielding mass, extra shielding placement, larger booms versus increases in Attitude Determination and Control System (ADCS) design,

---

<sup>36</sup>Joseph A. Angelo, Jr. and David Buden, Space Nuclear Power, (Malabar, Florida: Orbit, 1985), 113.

and secondary neutron emissions must be considered to optimize this problem. Also, the shielding issue must have an accurate neutronics measurement which will vary from reactor to reactor.

***b. Other Sources of Radiation***

Radiation from the power source is not the only source of radiation. Solar wind and galactic cosmic radiation (GCR) are those types of radiation which come from the sun and from other extrasolar sources, respectively. The table below shows the solar cycle as measured by the number of sunspots over the last thirty years.

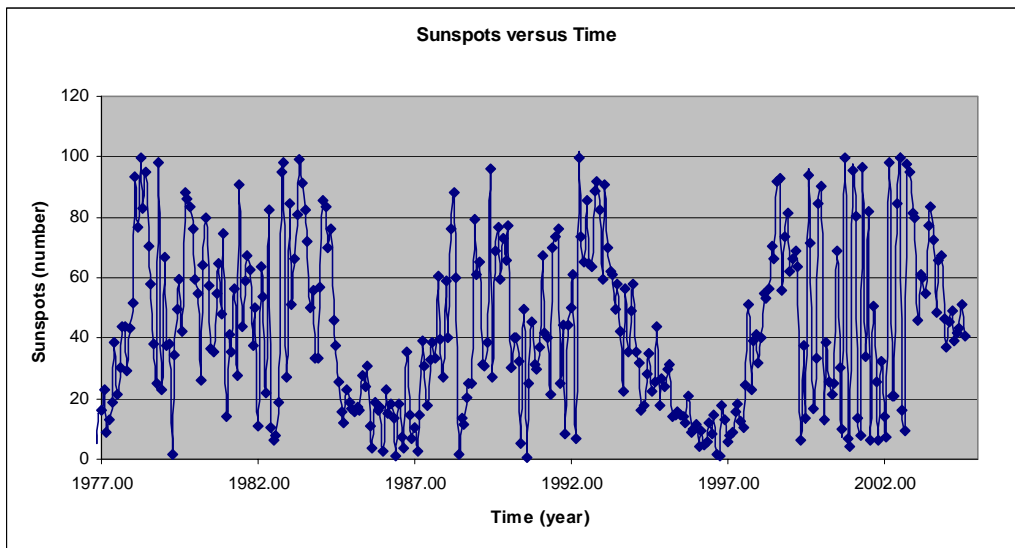

Table 6. Sunspot Activity versus Time of Measurement

The solar activity is a well documented eleven year cycle; however, solar particle events (SPE) are random in nature and could potentially deliver an acute dose exceeding 25rem (without the proper shielding). The ground support for the mission must include a solar watch to be able to relay potential SPE times to the crew to allow them to appropriately shield themselves. In addition to the nominal 35g/cm<sup>2</sup> shielding of the spacecraft a storm shelter of at least 20g/cm<sup>2</sup> of water equivalent material will be necessary for the crew to wait out the worst of a SPE.<sup>37</sup>

GCR is composed of highly energetic, ionized charged atomic nuclei. 87% is from hydrogen, 12% from helium, and the rest are trace amounts of uranium.

<sup>37</sup>Johnson Space Center, <http://srag-nt.jsc.nasa.gov/RadDocs/TM104782/techmemo.htm> (accessed November 22, 2004).

The energy levels can be as high as several thousand GeV per atomic mass unit.<sup>38</sup> Galactic cosmic radiation is not as predictably cyclical as the sun, but when the sun is at its peak, GCR is shielded by the sun's increased magnetosphere. When sunspot activity is at a low, GCR becomes more of an issue. The following graph shows the sun's affect on the lower energy particles and reduced affect on the higher energy particles.

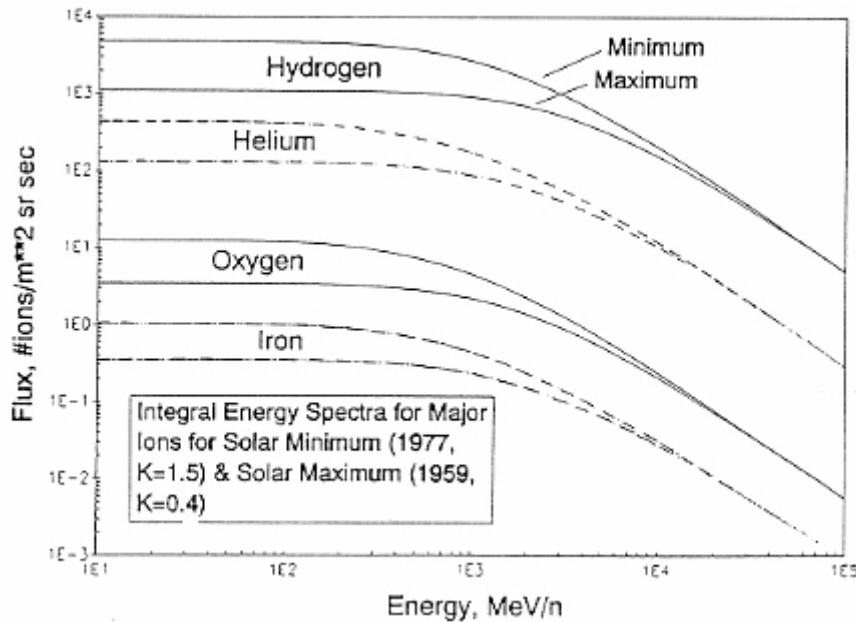

Figure 10. GCR Fluence as a Function of Solar Cycle Minimum and Maximum

The GCR dose rate in free space is 2.5 times higher at solar minimum than at solar maximum, and at solar minimum the exposure, unshielded, to blood forming organs (BFO) is estimated to be 60rem per year.<sup>39</sup>

<sup>38</sup>Johnson Space Center, <http://srag-nt.jsc.nasa.gov/RadDocs/TM104782/techmemo.htm> (accessed November 22, 2004).

<sup>39</sup>Johnson Space Center, <http://srag-nt.jsc.nasa.gov/RadDocs/TM104782/techmemo.htm> (accessed November 22, 2004).

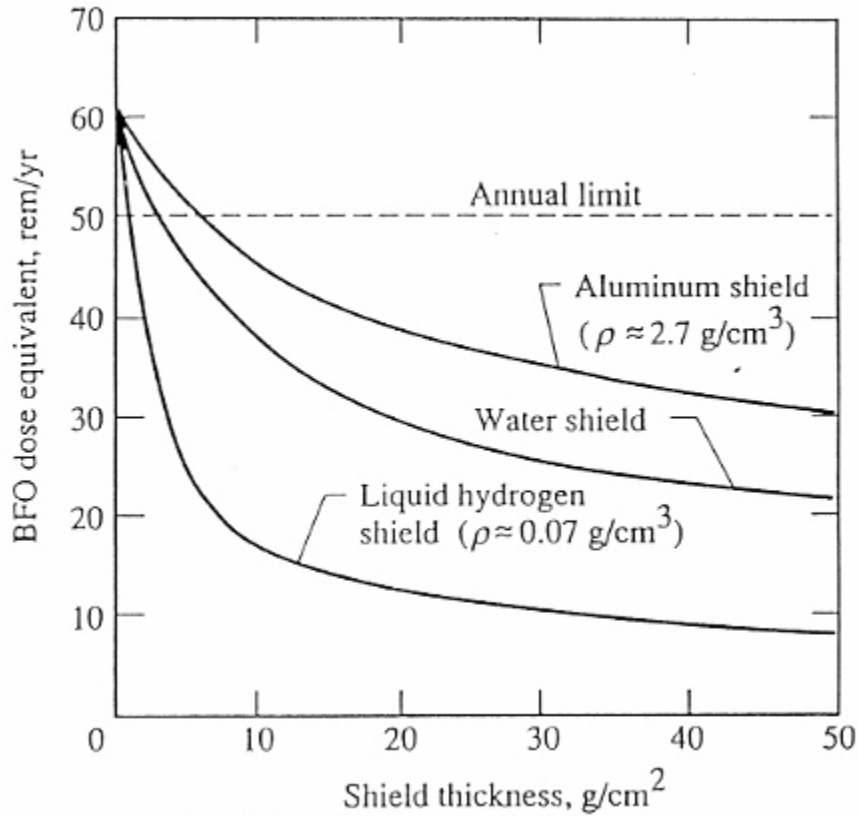

Figure 11. Shielding Effectiveness Against GCR at Solar Minimum<sup>40</sup>

A calculation of the total estimated dosage for a conjunction and opposition mission is shown in the table 9 using tables 7 and 8 below as well as estimated mission durations.

Condition	Unsheltered	Sheltered
Free Space, Solar Minimum	50	33
Free Space, Solar Maximum	20	15
Mars, Solar Minimum	13	8
Mars, Solar Maximum	6	4

Table 7. GCR dose data in rem/year\*<sup>41</sup>

\*unsheltered assumes 5g/cm<sup>2</sup> and sheltered assumes 35g/cm<sup>2</sup>

<sup>40</sup> Johnson Space Center, <http://srag-nt.jsc.nasa.gov/RadDocs/TM104782/techmemo.htm> (accessed November 22, 2004).

<sup>41</sup>Students for the Exploration and Development of Space, *Radiation and the Human Mars Mission*, <http://66.102.7.104/custom?q=cache:h2znAISZvrQJ:www.seds.org/pub/info/mars/RadHuman.mcw+rad+human&hl=en&ie=UTF-8> (accessed November 20, 2004)

Condition	Date	Unsheltered	Sheltered
Free Space	February-56	31	16
Free Space	November-60	37	7
Free Space	August-72	46	1
Free Space	Average	38	8
Mars	February-56	11	6
Mars	November-60	10	2
Mars	August-72	9	0.2
Mars	Average	10	2.73

Table 8. Solar Flare Radiation Dose\*<sup>42</sup>

\*free space data is for a spacecraft at 1AU – data is given based on three worst recorded flares on the dates shown

	Conjunction Class Dose (rem)		Opposition Class Dose (rem)	
	Solar Minimum	Solar Maximum	Solar Minimum	Solar Maximum
Outbound GCR	16.50	7.50	16.50	7.50
Solar Flare	4.00	4.00	4.00	4.00
Mars Stay GCR	12.48	6.24	0.67	0.33
Solar Flare on Mars	4.11	4.11	0.23	0.23
Return GCR	16.50	7.50	38.88	17.67
Solar Flare	4.00	4.00	9.42	9.42
Total	57.59	33.35	69.70	39.16
Dose Rate (rem/yr)	22.50	13.03	27.22	15.30

Table 9. Estimated Dosage for Astronauts Going to Mars

The following are the assumptions used for the mission durations:

- All phases of mission are “sheltered”
- Non-minimum energy conjunction mission of 180 day outbound and inbound trips
- The non-minimum energy conjunction mission requires a 550 day Mars stay<sup>43</sup>
- Opposition outbound leg mirrors conjunction outbound leg
- Opposition return leg uses a Venus gravity assist and a 430 day transit
- Exposure based on a 35g/cm<sup>2</sup> shielding
- Zero radiation from the reactor
- Solar Flare dose is the assumed average of the three worst recorded SPEs and the frequency is once per year

<sup>42</sup> Students for the Exploration and Development of Space, *Radiation and the Human Mars Mission*, <http://66.102.7.104/custom?q=cache:h2znAISZvrQJ:www.seds.org/pub/info/mars/RadHuman.mcw+rad+human&hl=en&ie=UTF-8> (accessed November 20, 2004)

<sup>43</sup> Robert Zubrin, *The Case for Mars*, (New York: The Free Press), 119.

With either the conjunction or opposition trajectories (see appendix for explanation of trajectories) the total exposure will be between 30-70 rem. No mission exceeds any yearly dose limit. And, no SPE estimated violates the acute dose allowed within a thirty day limit. With a storm shelter of 20g/cm<sup>2</sup> and proper cueing, the harsh effects of an acute dose from SPEs can be mitigated. Interestingly, the amount of radiation exposure increases as the solar cycle decreases due to GCR. This example clearly shows this phenomenon.

*c. Conclusion*

With the proper shielding, the manned Mars mission can be accomplished safely. The proper way to design a nuclear power system would be to first find the mission duration and destination. Second, calculate the expected dosage from the environment. The appropriate shield mass on board the human payload must be engineered. Finally, a boom versus reactor shield must be calculated with the minimum amount of shielding being determined by the equipment's radiation induced limitations. When compared to the analysis required to design an accurate space nuclear power system, this common sense exercise in shield design is simple yet rarely used.

**B. POWER CONVERSION SUBSYSTEMS**

Power conversion is the process where the heat generated by the reactor is converted to electrical energy. There are two types of power conversion techniques: static and dynamic. Static, or direct, power conversion includes using the thermo-physical properties of materials in order to convert the energy with no moving parts. Dynamic power conversion uses rotating machinery similar to terrestrial turbines.

**1. Static Power Conversion**

All of the currently flying space reactors (when critical) used static energy conversion. Direct power conversion reduces the number of moving parts, increases the simplicity, and increases the reliability of the overall system. However, direct power conversion efficiencies are low. Direct power conversion works on the Seebeck effect. Thomas Seebeck observed that an electromotive force, emf, is produced when two dissimilar metals are connected and maintained at different temperatures. A very basic application of the Seebeck effect is the thermocouple, a method to measure temperature.

More advanced applications of the Seebeck effect are semiconductor n and p junctions connected to a hot shoe on one side and a cold shoe on the other.

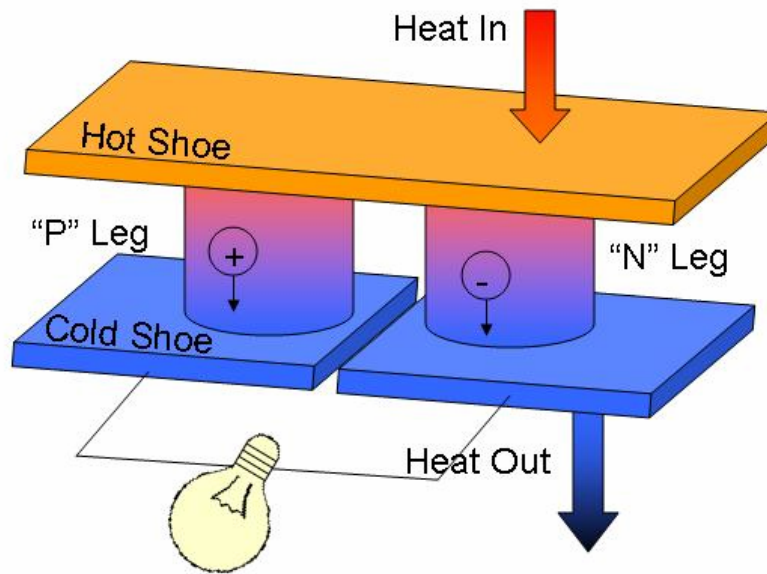

Figure 12. Operating Principle of Seebeck Effect and Thermoelectric Converter

Segmented Thermoelectrics (STE) are the next step in advanced thermoelectric design. STEs are comprised of two or more p and n legs which are designed to operate in different temperature ranges. Each material has an optimum temperature range; therefore, by combining them, the effective temperature range is increased. An increase in temperature range increases the overall efficiency. Using STEs and other variants of STEs efficiencies have been demonstrated at 10%. Possible increases include up to 16.08% resulting in a specific power of 10.7 We/kg for RTGs and possibly greater than 25We/kg for space nuclear reactors.<sup>44</sup> As can be seen by the low specific power for reactors, even at state of the art, static conversion techniques are not feasible for high power levels.

Another type of direct Power conversion is thermionic. Thermionics work on the voltage potential being produced between electrodes of different temperatures. Thermionics have competitive efficiencies with thermoelectrics and usually operate at

---

<sup>44</sup>Mohammed El-Genk, "Energy Conversion Technologies for Advance Radioisotope and Nuclear Reactor Power Systems for Future Planetary Exploration", 21<sup>st</sup> International Conference on Thermoelectronics, 2002, 3.

higher average temperatures. Thermionics were used in the Russian TOPAZ reactors but because of their high temperatures are life limiting.<sup>45</sup>

## 2. Dynamic Power Conversion

Dynamic Power conversion can be separated in to three different types: Rankine, Brayton, and Stirling. Each type utilizes the same thermodynamic cycle (expansion, rejection, compression, and addition), but with different mechanics and varying means. This allows the systems engineer a variety of dynamic power conversion methods to apply to various problems.

### a. Rankine Cycle

Rankine cycle utilizes a two phase working fluid. The basic steps are described here.

- 1-2 Isentropic Expansion
- 2-3 Isothermal Heat Rejection
- 3-4 Isentropic Compression
- 4-4' Isobaric Heat Addition
- 4'-1 Isothermal Heat Addition

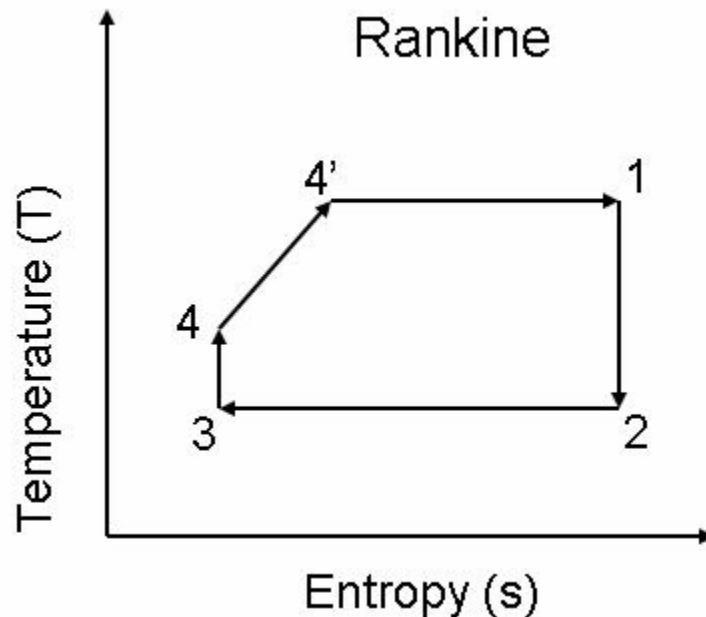

Figure 13. Ideal Rankine Temperature/ Entropy Diagram

<sup>45</sup> Lee S. Mason, "A Comparison of Brayton and Stirling Space Nuclear Power Systems for Power Levels from 1 Kilowatt to 10 Megawatts", STAIF, February 2001, Albuquerque, NM,3.

The working fluid at point one is a saturated vapor. It then goes through isentropic expansion, producing work by spinning the turbine. From two to three the fluid rejects the rest of its energy via the radiator while condensing back to a liquid. Three to four represents the pump compression, and four to four prime, the liquid is removing heat from the reactor at constant pressure, beginning its state change at four prime.<sup>46</sup>

Methods of increasing Rankine efficiency include superheating the gas after point one, reheating the working fluid where it is passed through the first stage of the turbine and sent back to the reactor to be heated at a constant pressure and sent to the second stage of the turbine, and regenerating the heat. Regenerating the heat includes using the excess thermal heat given off in the first turbine stage to preheat the fluid prior to its first pass through the reactor. By reducing the amount of moisture in the working fluid gas passing through the turbine blades and raising the average temperature at which thermal energy is added to the fluid, superheating, reheating, and regeneration can increase the overall Rankine efficiency.<sup>47</sup> Potassium Rankine systems will be discussed in a later section.

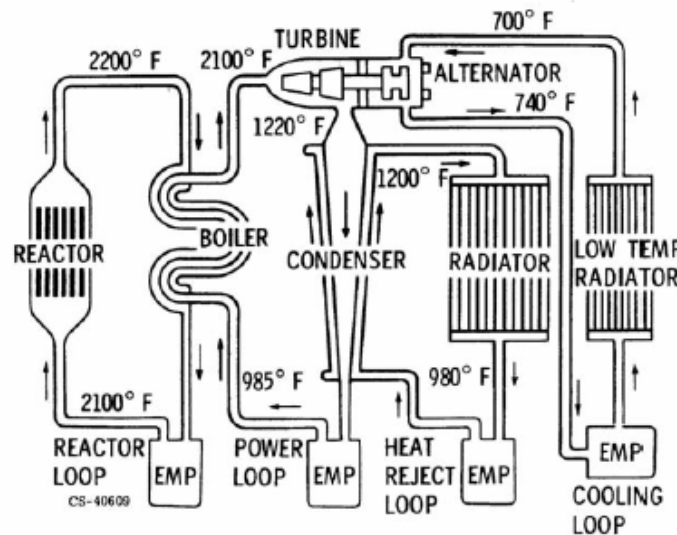

Figure 14. Example of Potassium Rankine System

<sup>46</sup>Joseph A. Angelo, Jr. and David Buden, Space Nuclear Power, (Malabar, Florida: Orbit, 1985), 79.

<sup>47</sup>Joseph A. Angelo, Jr. and David Buden, Space Nuclear Power, (Malabar, Florida: Orbit, 1985), 80.

**b. Brayton Cycle**

Brayton consists of a closed cycle gas turbine, alternator, and compressor on a single shaft. In addition to the shaft components a low temperature radiator, a high temperature heat exchanger, and a regenerator (or recuperator) are also needed. The basic steps of an idealized Brayton cycle consist of the following:

- 1-2 Isentropic Compression
- 2-3 Isobaric Heat Addition
- 3-4 Isentropic Expansion
- 4-1 Isobaric Heat Rejection

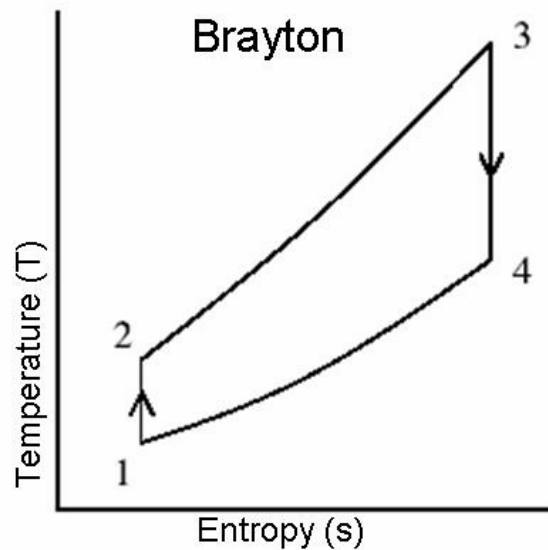

Figure 15. Ideal Brayton Temperature/Entropy Diagram

The working fluid during the entire process is a single phase idealized gas. As it goes from one to two, the working fluid is being compressed at constant entropy by the compressor. From two to three it is going through the reactor at a constant pressure, gaining energy in the form of heat. Three to four it is outputting work by isentropic expansion through the turbine, rotating at 30000-60000rpm.<sup>48</sup> And, four back to one the working fluid releases more heat energy to space via the radiator.<sup>49</sup>

<sup>48</sup> Leonard Dudinski, STAIF, short course notes, Albuquerque, NM, February 2004

<sup>49</sup> Joseph A. Angelo, Jr. and David Buden, Space Nuclear Power, (Malabar, Florida: Orbit, 1985) 82.

To increase the efficiency of the Brayton a regeneration cycle similar to the Rankine cycle can be used. Efficiency can also be improved by multi-level compression, multistage expansion with reheating, and reheating as with Rankine. Because there is no two phase flow, as in the Rankine, the likelihood of blade impingement by liquid droplets in the turbine is lessened. Working fluids include inert gasses such as a He-Xe mixture and Argon.

*c. Stirling Cycle*

The Stirling cycle consist of a displacer, a low mass piston, a regenerator, and a linear generator all in a sealed cylinder (see figure 17). The basic steps of an ideal Stirling cycle are as follows (refers to figures 16 and 18):

- 1-2 Isothermal Compression
- 2-3 Constant Volume Heat Addition
- 3-4 Isothermal Expansion
- 4-1 Constant Volume Heat Rejection

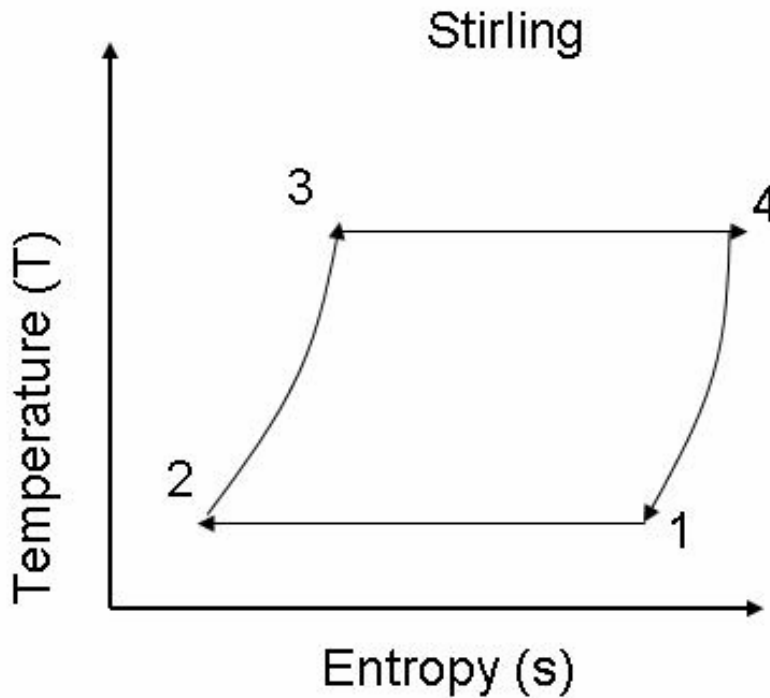

Figure 16. Ideal Stirling Temperature/Entropy Diagram

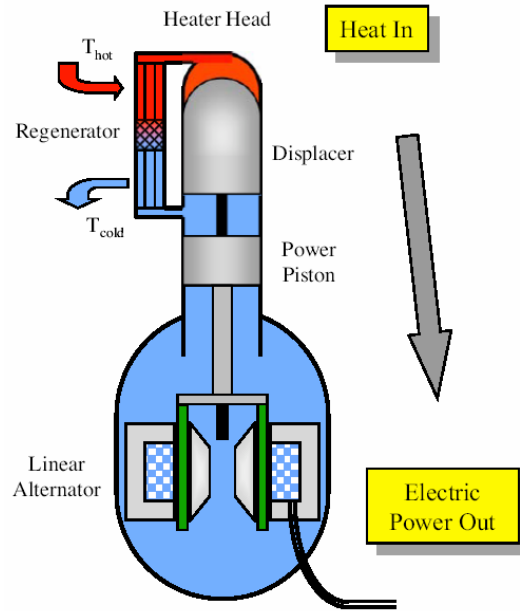

Figure 17. Example of Stirling Engine

The working fluid in a Stirling engine is an ideal gas. From one to two the gas undergoes isothermal compression as the low mass piston compresses the cold gas. At point two the gas is at  $T_c$  and recovers the stored heat from the regenerator in a reversible, constant volume process. Then from three to four the working gas expands isothermally due to heat addition from  $T_h$ , driving the heavy piston upwards and causing more heat transfer through the regenerator. Then the process repeats itself. The bottom piston moves up and down from 60-80 Hz through a linear generator.<sup>50</sup>

The regenerator is an important part of the Stirling cycle. An ideal regenerator is where the working fluid transfers its heat from the high temperature side to the low temperature side through a reversible process. It is usually made of a wire mesh or tiny thinned walled tubes. As the working fluid passes back through the regenerator at  $T_c$ , it regains the heat it gave off initially and leaves at  $T_h$ .<sup>51</sup>

<sup>50</sup> Lee Mason, STAIF, short course notes, Albuquerque, NM, February 2004

<sup>51</sup> Joseph A. Angelo, Jr. and David Buden, Space Nuclear Power, (Malabar, Florida: Orbit, 1985) 86.

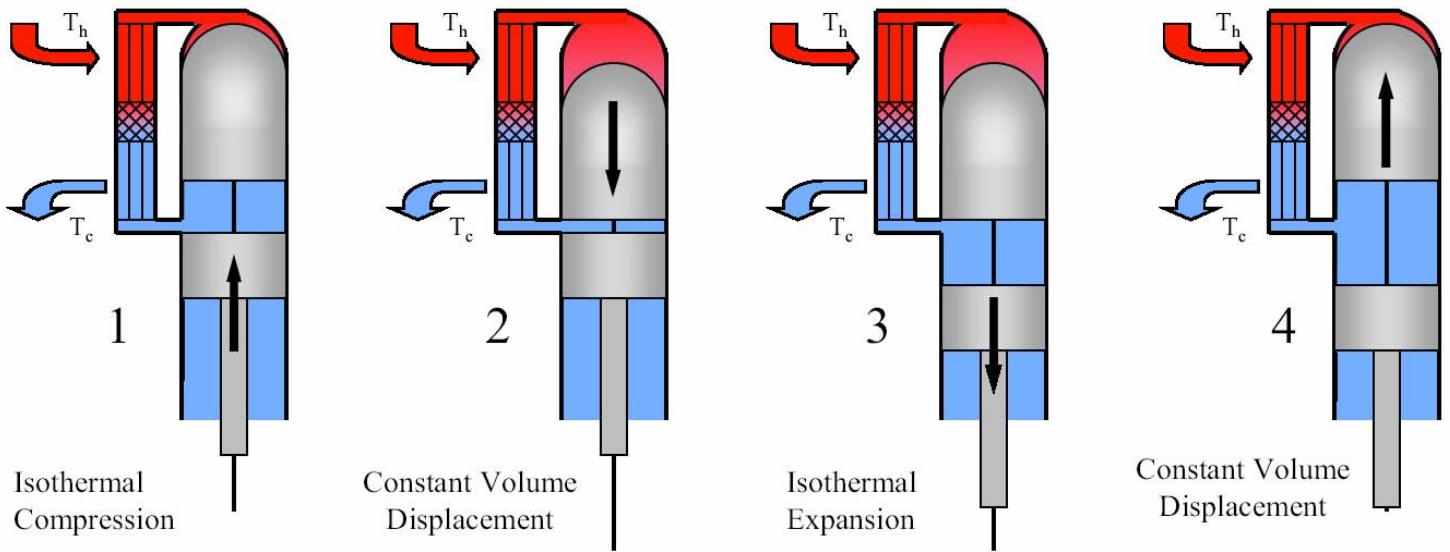

Figure 18. The Four Thermodynamic States of the Stirling Engine

*d. Comparison*

As can be seen by figure 19, the different types of power conversion suit different temperatures and perform with different efficiencies. Figure 7 (now figure 20) has also been placed beside figure 19 to better show the comparison. Obviously, the higher the efficiency the smaller the mass overall; however, comparing Stirling and Brayton at the same efficiency, the temperature of the Brayton is higher. A higher peak temperature allows for a smaller, more efficient radiator and an overall smaller mass. For MW operations as required by a manned Mars mission, the power conversion schemes with the lowest specific mass are Brayton and Rankine.

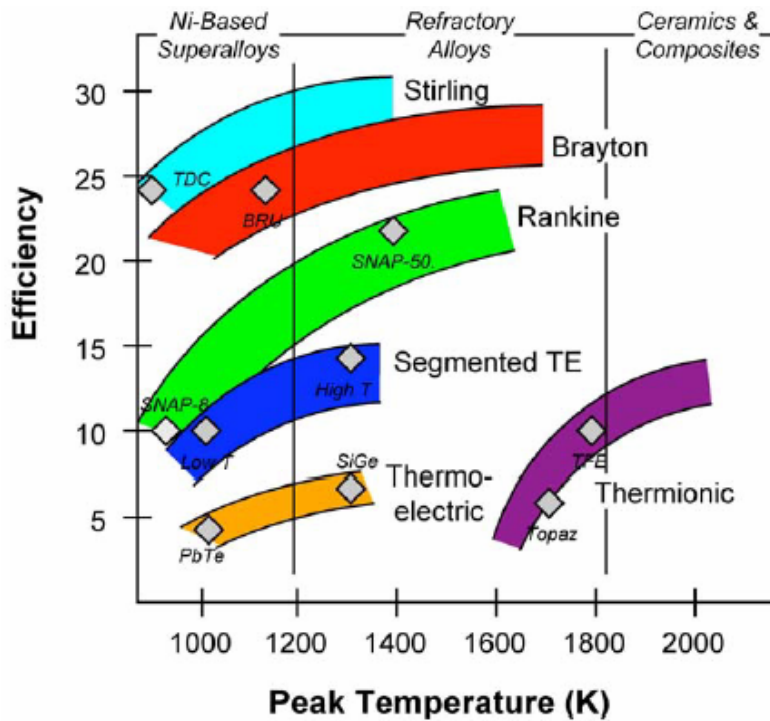

Figure 19. Overall Efficiency versus Peak Operating Temperature for Various Power Conversion Schemes<sup>52</sup>

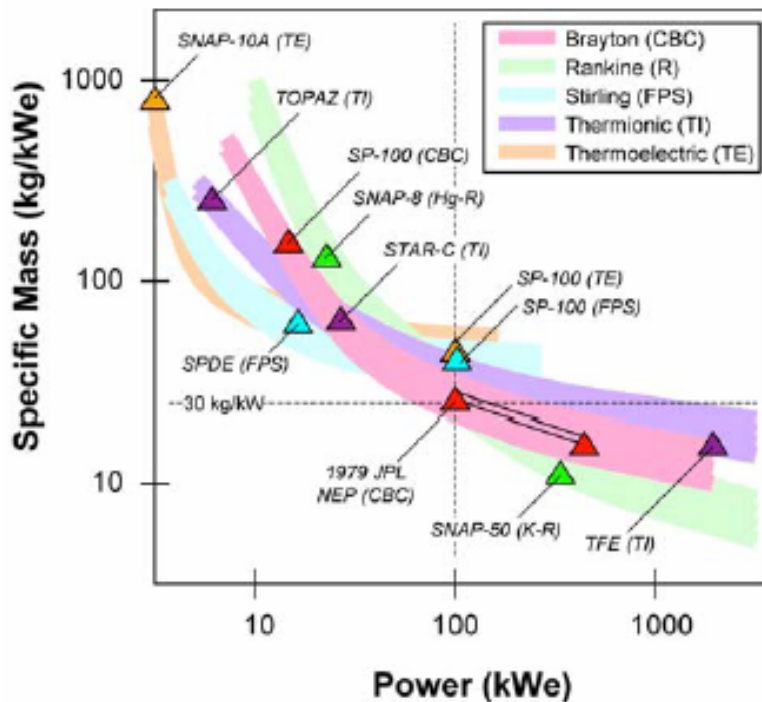

Figure 20. Overall Specific Mass versus Electric Power of Launched and Conceptual Designs<sup>53</sup>

<sup>52</sup> Leonard Dudinski, STAIF, short course notes, Albuquerque, NM, February 2004

<sup>53</sup> Lee Mason, STAIF, short course notes, Albuquerque, NM, February 2004

### C. HEAT REJECTION SUBSYSTEMS

Most power conversion techniques are below 30% efficient; the other 70% of the heat generated by the reactor must be dissipated to space. The only method of heat transfer available to a spacecraft to space is radiation. Radiative cooling is a common element among all spacecraft: manned, unmanned, planetary orbit, or interplanetary. Radiators commonly are a subsystem on all earth orbiting satellites; however, on multimegawatt (MMW) power systems the radiator can become up to fifty percent of the overall mass as shown in the figure 21. This mass contribution focuses design efforts towards increasing the power conversion efficiency and increasing the radiating temperature. By increasing the radiating temperature, the power conversion efficiency decreases due to a lower temperature difference across the system. Therefore, to raise the radiating temperature, a higher reactor temperature must be designed in order to maintain the temperature across the power conversion system and keep the radiator temperature high for thermal efficiency. The higher the reactor temperature the higher the material concerns and the lesser the reliability of the system.

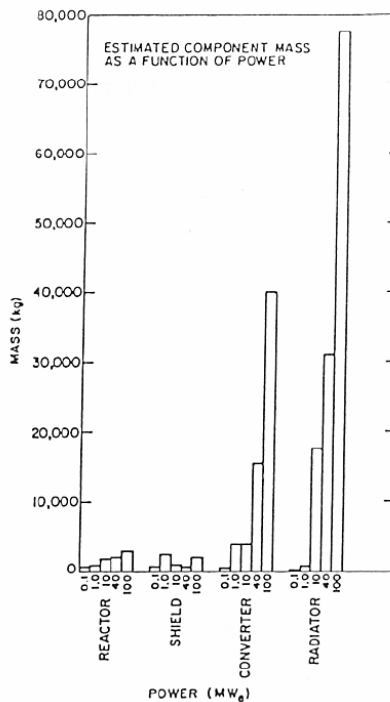

Figure 21. Mass Estimates versus System Power of Individual Components<sup>54</sup>

<sup>54</sup>David Buden and Joseph A Anjelo, *The Role of Nuclear Reactors in Future Military Satellites*, Los Alamos National Laboratory Paper LA-UR-82-1649, 8th DARPA Strategic Space Symposium, Monterey, CA, 1982.

By decreasing the amount of heat to be radiated (by increasing the power conversion efficiency), the size of the radiator necessary will decrease, lowering the radiator mass. To illustrate the temperature dependence of radiator size the Stephan-Boltzman relationship can be used:

$$R = \sigma \varepsilon T^4$$

Where: R= power radiated per m<sup>2</sup>

$\varepsilon$  = Emissivity (taken as unity for black body)

$$\sigma = 5.67 * 10^{-8} \left( \frac{\text{W}}{\text{m}^2 \text{K}^4} \right)$$

T= Temperature of the radiator (in K) <sup>55</sup>

It is easily seen that the power radiated from the radiator is directly proportional to the temperature to the fourth. Although high temperatures reduce radiator size, high temperatures also decrease system reliability, reduce lifetime, and require higher material strengths. Radiator performance is measured by their specific mass, defined as mass divided by area of radiator.

### 1. Heat Pipe Radiators

One of the simplest radiator designs, the heat pipe radiator, utilizes both heat pipes and fins to reject higher heat loads. Because volume is the second restriction, after mass, heat pipe radiators are typically constructed with a stowed and deployed configuration, increasing their complexity. Many shapes and designs exist. For example the Jupiter Icy Moons Orbiter is typically seen with a flat plate radiator within the shadow of the reactor's shield. Any deployment features in a heat pipe radiator increases the complexity of the radiator and the likelihood of a failure. Also heat pipe radiators are susceptible to micrometeoroid impacts; therefore, redundancy is required in all heat pipe radiators. A bumpered (or shielded) carbon/carbon composite radiator with a high emissivity is the most likely type of high temperature (greater than 750K) radiator used.

---

<sup>55</sup>Christopher Olsen, Naval Postgraduate School, Monterey, CA, Class Notes, PH2514, Introduction to the Space Environment, 13.

## 2. Pumped Loop Liquid Metal

The pumped loop radiator design consists of an electromagnetic pump, a radiating surface, a working fluid, and an accumulator. The accumulator works similar to a pressurizer on a terrestrial reactor. It acts as an expansion volume as well as maintains a constant pressure in the system. The working fluid can be either a liquid metal or an organic liquid. Because the heat pump radiator suffers heat losses around the pumped loop, it must operate at a lower than the rejection temperature at the discharge end of the power conversion system.<sup>56</sup>

## 3. Liquid Droplet Radiators

A more advanced concept involves the use of the liquid drops to radiate the excess energy. The Liquid Droplet Radiator (LDR), as seen below, uses a droplet generator and droplet collector to form liquid jets of droplets, maximizing the surface to volume area, in order to radiate energy between the generator and collector. At the collector the droplets are combined back into a liquid and pumped back to the heat exchanger and out the generator. The liquid streams serve the same purpose as do the fins on the heat pipe radiator. This approach reduces the risk of micro meteoroid impact upon the radiator, reduces the storable size required on the launch vehicle, and most importantly lowers the mass of the radiator three to four times.<sup>57</sup>

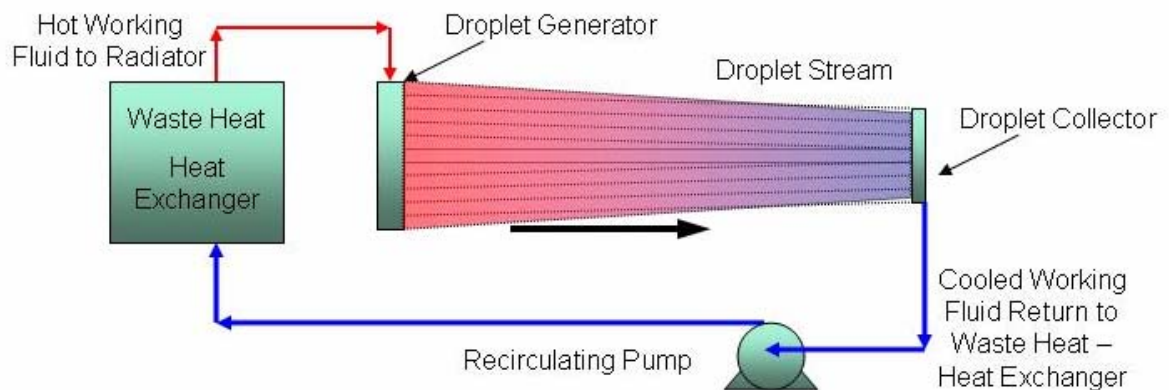

Figure 22. Liquid Droplet Radiator Concept

<sup>56</sup>Joseph A. Angelo, Jr. and David Buden, *Space Nuclear Power*, (Malabar, Florida: Orbit, 1985)104.

<sup>57</sup>Jason R. Feig, "Radiator Concepts for High Power Systems in Space", Air Force Rocket Propulsion laboratory, *Space Nuclear Power Systems*, M. S. El-Genk and M. D. Hoover eds, (Malabar, FL: Orbit Book Company, 1985).

## **D. MATERIALS**

If a subsystem can be likened to an organ in the body such as the heart or lungs, the materials would be considered the skin, the largest organ which holds the rest of the system together. Material issues permeate throughout the entire power system design beginning with the fuel and ending with the truss structure. In this section a short synopsis of the most common materials used in space nuclear power systems will be reviewed.

### **1. Alloys**

When reviewing the candidate materials for use in a space nuclear power system, it is necessary to review the following properties:

- Manufacturing capability, availability, and cost
- Mechanical and thermophysical properties
- Irradiation effects
- Chemical compatibility and corrosion properties
- Nuclear properties (such as cross section for absorption)<sup>58</sup>

The candidate materials for high power space nuclear power system structures in the 1300K-1400K range are the refractory metals Niobium, Tungsten, Molybdenum, Rhenium, and Tantalum. Super alloys do not have the strength at these temperatures and the more exotic materials such as carbon/carbon and ceramics cannot be fabricated into these complex systems.<sup>59</sup>

Niobium metals are used in the form of Niobium with 1% Zirconium (Nb-1Zr) and Nb-1Zr with 0.1 percent carbon are called PWC-11. 172,763 hours of creep testing has been performed on Nb-1Zr in 1960 and 34 creep tests have been performed for a total of 320,650 hours in 1986. PWC-11 was tested less than Nb-1Zr but was developed to increase the creep strength of Nb-1Zr yet proved to have less strength than Nb-1Zr.<sup>60</sup> In irradiation testing, Nb-1Zr becomes brittle less than 800K. At temperatures above 1100K

---

<sup>58</sup> Steven J. Zinkle and F.W. Wiffen, "Radiation Effects in Refractory Alloys", STAIF, February 2004, Albuquerque, NM, 733.

<sup>59</sup> P.J. Ring and E.D. Sayre, "Material Requirements, Selection, and Development for the Proposed JIMO Space Power System", STAIF, February 2004, Albuquerque, NM, 808.

<sup>60</sup> R.W. Buckman, "Nuclear Space Power Systems Materials Requirements", STAIF, February 2004, Albuquerque, NM, 815.

the elongation of Nb-1Zr has experimentally been shown to become significant.<sup>61</sup> Nb-1Zr is compatible with many liquid metal coolants and has a favorable cross section for absorption in the fast spectrum.

Tungsten is considered only as a shielding material. Because it is highly dense it is a great gamma shield, but because it is dense it is heavy and unsuited for any other space nuclear power system applications. Tungsten has a low fracture toughness even above its ductile to brittle transition temperature (DBTT). Low temperature irradiation tests of tungsten shows it has a severe radiation hardening embrittlement below 1200K.<sup>62</sup> Tungsten, as part of the shield, should be placed closest to the reactor to ensure it is kept at a higher temperature and to reduce the mass of the tungsten necessary. Tungsten is also extremely difficult to fabricate and weld; therefore, the only effort in using tungsten should be in the shield design.

Three molybdenum alloys were considered for use and tested in the 1960s: Mo-TZM (Mo-0.5%Ti-0.1%Zr-0.03%C), Mo-TZC (Mo-1%Ti-0.3%Zr-0.15%C), and Mo-13%Re. Mo-13%Re is the most likely molybdenum alloy to be used as cladding, yet because molybdenum is extremely difficult to weld and has poor properties after welding, it cannot be used in most of the power system components.

Nb-1Zr was the cladding choice for SP-100. It had the most favorable characteristics of all the refractory metals, yet it is not compatible with the fuel. Because of this a sleeve liner must be in place between the cladding and the fuel. Rhenium was chosen for this sleeve. Rhenium interacts well with both cladding and fuel and it can be fabricated as a sleeve. In addition, rhenium has a low cross section for absorption for fast neutrons and a high cross section for absorption for thermal neutrons. Therefore, rhenium gives the added benefit of reducing the chance of criticality in a water submersion accident.<sup>63</sup>

---

<sup>61</sup> Steven J. Zinkle and F.W. Wiffen, "Radiation Effects in Refractory Alloys", STAIF, February 2004, Albuquerque, NM, 735.

<sup>62</sup> Steven J. Zinkle and F.W. Wiffen, "Radiation Effects in Refractory Alloys", STAIF, February 2004, Albuquerque, NM, 735.

<sup>63</sup> P.J. Ring and E.D. Sayre, "Material Requirements, Selection, and Development for the Proposed JIMO Space Power System", STAIF, February 2004, Albuquerque, NM, 808.

There are two major tantalum alloys: ASTAR-811C (Ta-8%W-1%Re-1%Hf-0.025%C) and T-111(Ta-8%W-2%Hf). ASTAR-811C has superior creep properties to T-111, yet it still retains the fabrication and welding characteristics of T-111. Both alloys were tested satisfactorily with lithium coolant.<sup>64</sup> Tantalum alloys are significantly stronger than niobium, but they have higher fast neutron cross sections of absorption, are twice as heavy, and are more difficult to weld than niobium. In DBTT tests irradiated tantalum alloys showed brittle behavior in temperatures less than 1000K.<sup>65</sup>

In choosing alloys for space nuclear power systems no one alloy is perfect. For the United States' next space reactor under JIMO, Nb-1Zr should be the alloy of choice. It is easily fabricated, has high ductility and melting point, a low DBTT, and a low density. For higher power systems of the future, the relatively low strength of niobium will become more of a concern. Tantalum alloys must be considered to allow the higher power systems to work at higher temperatures.

*a. Needed Tests for Near and Long Term Space Nuclear Power System Flight*

The following tests need to be performed to increase the database for material studies of space nuclear power systems:

- Irradiated tests on tungsten and tungsten-rhenium alloys in the 950-1300K range<sup>66</sup>
- Reactor fast fluence testing
- Bonded rhenium barrier cladding long duration fission product build up tests<sup>67</sup>
- Charpy impact or fracture toughness tests on tantalum irradiation samples at high temperature
- PWC-11 testing-irradiation and fracture toughness tests

---

<sup>64</sup> R.W. Buckman, "Nuclear Space Power Systems Materials Requirements", STAIF, February 2004, Albuquerque, NM, 818.

<sup>65</sup> Steven J. Zinkle and F.W. Wiffen, "Radiation Effects in Refractory Alloys", STAIF, February 2004, Albuquerque, NM, 733.

<sup>66</sup>Zinkle and Wiffen, 733.

<sup>67</sup> P.J. Ring and E.D. Sayre, "Material Requirements, Selection, and Development for the Proposed JIMO Space Power System", STAIF, February 2004, Albuquerque, NM, 813.

## 2. Lithium

Lithium is considered for two aspects of the power system. One is the primary cooling fluid and the other is for the neutron shield as Lithium Hydride. Lithium Hydride has a high hydrogen density ( $5.9 \times 10^{22}$  hydrogen atoms/cm<sup>3</sup>), low mass density (0.775g/cm<sup>3</sup>), and moderately high melting point of 960K, and produces a minimal amount of secondary radiation. Lithium Hydride has the unfavorable property of expanding up to 25% when it reaches its melting temperature, which underlines the fact that the shield must be actively cooled to prevent temperatures from reaching this point. Also, lithium has a high thermal neutron cross section for absorption. If too much lithium<sup>6</sup> is present, than a large amount of helium could be generated in the shield. This can be avoided by enriching the LiH with 99.99%Li<sup>7</sup>.

Liquid lithium used as a primary coolant must be kept above its melting temperature of 454K. The reason lithium is used as a primary coolant over NaK, which was used in SNAP-10A, is that SNAP-10A operated at 816K. NaK operating range is 800-980K. At higher power levels, such as the MW range, higher temperatures are mandatory to meet performance requirements; therefore, lithium or mercury are the primary candidates. Mercury has the disadvantages of being heavy and having a high cross section for absorption of fast neutrons.<sup>68</sup> Lithium also has the advantages of low vapor pressure, low density, and high specific heat. These advantages lead to a lower operating pressure which is less stressful on the reactor components and allows for thinner piping walls. High specific heat and low density, lower the pumping requirements, making the pump more reliable. And, if oxygen levels are kept low in the coolant and in the cladding, there will be minimal corrosion due to the coolant.<sup>69</sup>

---

<sup>68</sup>Joseph A. Angelo Jr. and David Buden, Space Nuclear Power, (Malabar, Florida: Orbit, 1985) 63.

<sup>69</sup> P.J Ring and E.D. Sayre, "Material Requirements, Selection, and Development for the Proposed JIMO Space Power System", STAIF, February 2004, Albuquerque, NM, 813.

THIS PAGE INTENTIONALLY LEFT BLANK

### III. DESIGN CONCEPTS

Many design concepts of reactors, power conversion schemes, radiators, and propulsion systems exist in current literature. The following examples are today's most realistic and technologically feasible designs for systems which can provide power in the 1-15MWe range. The Pellet Bed Reactor System is a relatively new design, where the Potassium Rankine system has been around since the 1960s. The SP100 derivative is an evolutionary design from the SP100 era of the late 1980s and early nineties. Each of these designs gives a specific mass, which will be analyzed against a statistical fit in the following section.

#### A. PELLET BED REACTOR CONCEPT

The Pellet Bed Reactor (PeBR) Concept utilizes a common reactor type for both NEP and NTR applications. Since this paper is only focusing on NEP the NTR concept will not be presented. The overall specific mass for the system is 3.29 kg/kWe.

##### 1. Nuclear Subsystem

The PeBR is a helium gas cooled, fast spectrum reactor. The fuel is in the form of 10mm diameter pellets. The core is separated in to three 120degree sectors. Each sector is fully contained and can be operated individually or in concert with one or two other sections. Each of the 120 degree sections is filled with the fuel pellet (similar to a "pool of balls"). The power output of each sector is 16.3 MWt.

The uniqueness of the PeBR is in its fuel design. Each fuel pellet contains hundreds of TRISO-type fuel microspheres dispersed throughout a graphite matrix. The microspheres contain a UC-ZrC fuel kernel (approx. 400-500 micrometers in diameter) with three coatings:

- Inner coating of low density, pyrolytic graphite 15microns thick
- Intermediate coating of high density graphite 5-10 microns thick
- Outer coating of ZrC 10 microns thick

The fuel particles serve as the first pressure vessel for the containment of fission products. UC-ZrC fuel has a melting temperature of 3693+/-20K at low carbon content and 3123+/- 50K at high carbon content.

The shield is a typical LiH and W double layered shadow shield located outside of the reactor pressure vessel. Actively cooled by the reactors' helium working fluid, the shield is maintained below 500K. Potassium radiators are attached on the shields to aid in decay heat removal. Decay heat is removed from the vessel via conduction to these radiators and radiation to space.

Two independent control systems are implemented with 15 segmented Be<sub>2</sub>C/B<sub>4</sub>C control drums spaced equally within the radial Be<sub>2</sub>C reflector and 6 B<sub>4</sub>C safety rods at the 0.2 meter radial distance from the center. The control drums keep the reactors subcritical during launch and with the control rods are sufficient to prevent criticality in a water submersion casualty.

## 2. Power Conversion Subsystem

Each of the three individual sectors of the PeBR system contains its own Closed Brayton Cycle (CBC) power conversion system. Each CBC utilizes the same helium gas coolant to produce 5MWe.

## 3. Heat Rejection Subsystem

The unique design of the heat pipe radiator covers 5300 square meters of area. It radiates at an average temperature of 645K. Using the Stephan-Boltzman relationship and an emissivity of 0.80, that means that it radiates approximately 7.85kW per square meter. At 5300 square meters, that equals 41.6MW radiated to space, which conservatively corresponds to their design specifications.

Parameter	Value
Total Thermal Power	50MWt
Total Electric Power	15MWe
Overall System Efficiency	29.1
Maximum Fuel Temperature	2200K
Total System Mass	49300kg
Specific Mass	3.29kg/kWe

Figure 23. Parameters of the PeBR concept Design

The PeBR concept offers many advantages in its design, including:

- Safety in either launching with or without fuel
- Capability of refueling in orbit
- Multiple layers of Redundancy
- Negative temperature coefficient of reactivity
- Passive decay heat removal system
- Favorable non nuclear testing possibilities

However, the low specific mass does not take in consideration the power conditioning system. Also, the temperatures of the fuel, power conversion system, and radiator are unusually high. At 2000K, efficiencies will definitely be high, lowering the specific mass of the overall system. There is no mention of material development or issues to be addressed at operating at these extremely high temperatures. Without major developments in fuels and material, this concept's specific mass is likely to increase.

## **B. POTASSIUM RANKINE SYSTEM**

The Potassium Rankine System (KRS) has been in conceptual development since the 1960s. The following designs presented are three designs from different organizations, one a NASA sponsored 2001 Rocketdyne design, another an ORNL 1983 design based on the Medium Powered Reactor Experiment (MPRE) design of 1966, and the last a 1993 NASA internal study on a NEP architecture for a manned Mars mission using KRS based on a scale up of SP-100. Each of these uses a KRS and a fast reactor. The following sections will compare and contrast them inside of three of their subsystems.

### **1. Nuclear Subsystem**

#### ***a. Rocketdyne***

The 2001 Rocketdyne reactor is liquid metal cooled and hexagonally cermet fueled with UNW-25Re. The system is designed with one reactor and three power conversion systems producing 10MWe. UC was considered, but deemed too risky due to the unknown chemical interactions with the cladding. Cooled with liquid lithium, the reactor operating temperature is 1550K based on refractory metals limit. UN pin

type fuel was considered as well. The cermet fuel has a higher strength and higher thermal conductivity than the pin type. However, there is more data and experience with pin type fuels.

The shield is a monocoque shape with a 17.4 degree cone half angle. It is made with a reactor side of tungsten 8.2 cm thick and a payload side of Be<sub>2</sub>C/B<sub>4</sub>C 62.6 cm thick. The shield allows a 5rem/yr dose rate at the dose plane positioned 100m behind the shield.

***b. ORNL***

The ORNL design is based upon the MPRE of the early 1960s. The reactor is a fuel pin, UN pellet with T-111 alloy (Ta-8W-2Hf) cladding with a W liner between the UN and T-111 cladding. The reactor operating temperature of 1365K supplies a final supply of 99% quality liquid potassium to the turbines. Average fuel burnup is 6 at.%. The shield design is a very common alternating layers of LiH and W with varying thicknesses of between 50 to 70 cm. The dose rate 20m away from the shield is  $10^{13}$  neutrons/cm<sup>2</sup> and  $10^6$  rad of gamma.

***c. NASA***

NASA's current Design Reference Mission (DRM) utilizes NTP as the benchmark propulsion system. In 1993 NASA produced a rival architecture based on NEP. Even though some assumptions have changed the basic design of the propulsion system, the NEP architecture presented is accurate enough to establish a baseline estimate of NEP power system parameters. They use a 24MWt, UN pin type, SP-100 derived, lithium cooled reactor. The reactor outlet temperature is 1375K and utilizes a KRS for power conversion.

**2. Power Conversion Subsystem**

***a. Rocketdyne***

Rocketdyne's KRS utilizes three turbines with one backup. Each system cools the reactor concurrently. The output voltage is 10,000VDC. The turbine inlet temperature limit is 1350K. This temperature reduces the amount of tantalum necessary in the primary loop and allows niobium alloys which are lighter to be used. However, this lower temperature lowers the temperature at which the radiator operates and

increases the mass of the radiator. Optimization studies were done to show that the trade offs minimize mass at these temperatures.

***b. ORNL***

The KRS seven stage turbine has a 83% efficiency, spinning at 1050 rpm. The output voltage is 1000 V at 2000Hz.

***c. NASA***

Each of the two reactors utilizes three 2MWe KRSs for a fifty percent redundancy feature. This provides a total system output of 8MWe for the manned mission and 4MWe for the unmanned. Their output voltage is 1400VDC at 2000Hz. 1400VDC was shown to be lighter than a more efficient 5000VDC PMAD system.

**3. Heat Rejection Subsystem**

***a. Rocketdyne***

The heat pipe radiator is a carbon/carbon potassium working fluid composite structure with Nb-1%Zr coating. The auxiliary radiators use both mercury and water for working fluids. Its rejection temperature is between 1000-1025K. Combined total heat transfer area is 899 m<sup>2</sup>. Advanced radiator studies have shown a possible mass savings of 6480kg for a 10MWe 2yr mission system. Micrometeoroid impact analysis was done on the radiator structure.

***b. ORNL***

The primary radiator has three manifolds of 17.8 meters each operating at 1020K. They are arranged in three flat plate manifolds, 120 degrees apart. Each heat pipe is 2.5 cm diameter with a 1.7m inner set and 4.42 m outer set. Combined the total heat transfer area is 660 m<sup>2</sup>.

***c. NASA***

The primary heat rejection temperature is 975K in the potassium heat pipe radiators. Mass estimates are based on a 5kg/m<sup>2</sup> which are SP-100 based.

**4. Comparisons**

When placed next to each other, similar KRS designs show different assumptions which translate in to grossly different specific masses. Each system utilizes the same radiator type and working fluid, the same fuel material, and the same shielding materials, yet the specific masses range from 4-10 kg/kWe.

System	Rocketdyne	ORNL	NASA
Power Output (MWe)	10	5	4
Lifetime (years)	2	5	5
Reactor Power (MWt)	52	28	24
Overall Efficiency	0.192	0.179	0.167
Number of Systems	1	1	2
Fuel Burnup %	25	6	assume 6
Fuel Type	Hex-Cermet	Pin	Pin
Payload distance from Rx (m)	100	20	60
Voltage (KVDC)	10	1	1.4
Frequency	460	2KHz	2KHz
Radiator Type	C/C K-heat pipe	C/C K-heat pipe	C/C K-heat pipe
Radiator Temperature (K)	1000	1020	975
Waste Heat	42MW	23MW	20MW
Radiator Area (m <sup>2</sup> )	899	660	636
Waste Heat/Area (kW/m <sup>2</sup> )	46.72	34.85	31.45
Radiator (kg/m <sup>2</sup> )	3.87	8.33	6.57
Number of Power Converters	4	1	3
% PC redundancy	25	0	50

Figure 24. Comparisons of Similar KRS

The reason the masses are different is because of a much higher burn up assumption of the UN fuel for the Rocketdyne system. They assume a 25% burnup, yet BWX Technologies has shown that UN performs well between six and ten percent burnup.<sup>70</sup> Beyond this fuel burnup, fission product buildup causes swelling and cracking of the cladding structure. Therefore, the 25% assumption is grossly flawed. The other two designs show a significant difference in their specific masses plus a difference in the required amount of power to send a manned mission to Mars (the NASA mission requires two 4MWe power sources). 5MWe is not sufficient to meet the duration in space requirement for a manned Mars mission. Although 5MWe is not sufficient, the design does give a nice data point in order to somewhat validate the NASA design, which does not use this design in its analysis. The ORNL design was completed prior to SP-100 and the NASA design after SP-100. Possibly the SP-100 design used the ORNL design which was then used by NASA. So this comparison might be incorrect.

<sup>70</sup> W. J. Carmack, D.L.Husser, T.C.Mohr, and W.C.Richardson, "Status of Fuels Development and Manufacturing for Space Nuclear Reactors at BWX Technologies", STAIF, February 2004, Albuquerque, NM, 426.

System	Rocketdyne	ORNL	NASA
Power	10MWe	5MWe	4MWe
Reactor	4500	3500	3810
Shield	6930	11000	9760
Primary, Auxiliary loop	11702	in shield	in shield
Power Conversion System	12060	4500	7860
Heat Rejection System	4435	5500	4180
Structure	included	included	4650
Power Conditioning System	468	included	11250
Total	40095	24500	41510
Specific Mass (kg/kWe)	4.0095	4.9	10.3775

Figure 25. Mass Breakdown of Three Competing KRS Designs

### C. SCALEABILITY OF THE SP-100 PROGRAM

The SP-100 program, as discussed earlier, is the benchmark of recent space nuclear power studies. In a 1991 study, the SP-100 space power system was scaled up to a 5, 10, and 40 MWe system. The reactor is still a highly enriched, UN, lithium cooled fast reactor. The authors used a  $6\text{kg/m}^2$  assumption to estimate the radiator mass. Their burnup rate is never stated but they state they only had to modestly increase the SP-100 assumption. Unlike SP-100, thermoelectrics were not considered. A reason was not given for this, but the assumption can be made that at the higher power levels the benefits of static conversion are overshadowed by the low efficiency translating to a very large radiator mass. The design life was extended to a full 10 years of operation instead of an operational life of ten years and full power lifetime of 7.3 years. The last change was to increase the operational temperature to 1400K from 1350K.

System	Rankine	Brayton	SP-100
Power	25MWt	25MWt	2.4MWt
Output power	5MWe	5MWe	0.1053MWe
Lifetime	10	10	7.3
Reactor	4200	4200	700
Shield	3930	3930	1037
Structure	incl in S/S	incl in S/S	538
Primary Heat Transport System	1550	1550	500
Power Conversion System	31140	56140	409
Heat Rejection System	appr4180	appr4180	1027
Power Conditioning System	incl in PC	incl in PC	399
Total	45000	70000	4610
Specific Mass (kg/kWe)	9	14	43.78

Table 10. Mass and Power Comparisons of SP-100 Program and Scaled SP-100<sup>71,72</sup>

<sup>71</sup>Douglas Newkirk, Samir A. Salamah, and Samuel L. Stewart, "SP-100 Scaleup to 40MWe", General Electric Company, 1991, American Institute of Physics.

## **D. ADDITIONAL ANALYSIS OF POWER SYSTEM DESIGNS**

The five candidate designs presented in this section are an accurate cross section of all available designs. Each design has varying levels of detail and some are more advanced (meaning longer term technologically). A few design flaws have been pointed out in the description of system. Overall, the following operational concerns have not been discussed and are assumed not accounted for in the engineering of the system. Yet, all of the following must be considered when designing a space nuclear power system.

### **1. Restart Capability**

All operational reactors must have a restart capability. No engineering model can predict all scenarios which would cause a reactor shutdown, and an automatic reactor shutdown mechanism must be in place to protect from a reactor accident, leaving the reactor useless. SNAP-10A did not have a restart capability, but no one was relying on its power as life support. Restarting the reactor must be a quick procedure as evidenced by the *USS Thresher*\*. If the reactor has not built up enough decaying fission products, the decay heat might not be sufficient to keep the liquid metal coolant liquid. This is another reason the reactor needs to be restarted quickly. For a manned Mars mission the communication's lag between earth and Mars requires one member of the crew to have adequate knowledge to find the cause of shutdown, understand the implications, and be able to correct it quickly enough to safely restart the reactor in order to limit its thermal stresses.

### **2. Backup Power Requirements**

The nuclear submarine design is durable because of the flexibility in the power source design. The reactor continually charges a battery, and a diesel engine is always available to provide power on or near the surface of the water. If the reactor should shutdown, the battery provides enough power to maintain crucial systems while the reactor's cause for shutdown is found. Battery power is sufficient to bridge the gap between reactor shutdown and subsequent restart or for the preparations for starting the diesel. Space nuclear power does not have the luxury of being "near the surface". This is

---

<sup>72</sup> SP-100 Project Integration Meeting Notes, General Electric, Long Beach, CA July 19-21, 1988.

\**USS Thresher* was lost with all hands on April 10, 1963. One of the lessons learned from the tragedy was that if they had been able to quickly restart the reactor the consequences would not have been as severe. Subsequently, all US naval reactors now have a fast recovery startup procedure.

what makes the design more complicated and reliability more important. Reliability cannot be defined solely by redundancy. Redundant faulty designs do not combine to make a safe design. This important reliability requirement makes the launching of a cargo mission using the same power and propulsion systems as the human mission, 26 months earlier, mandatory for a safe manned flight.

Backup power sources need to be able to meet the demand of hotel loads, reactor restart, and coolant heating. Backup power sources could be RTGs, fuel cells, or solar cells (a backup chemical system would defeat the purpose of using NEP). RTGs could be used in the primary piping as a heat source for maintaining the coolant above melting temperature. Fuel cells could use the same hydrogen used for propulsion or for shielding. For a manned mission, there will definitely be two reactors (if not three). One reactor should be able to supply the power to restart the other reactor while simultaneously powering hotel loads. A backup power source can be used intermittently for life support to ensure operability and have the capability to support hotel loads while supplying power for a reactor restart and maintaining the coolant temperature. A balance between redundancy, reliability, and mass efficiency must be kept when designing a space nuclear power source.

### **3. Power Management and Distribution**

The power management and distribution system is one of the least designed areas in space nuclear power. Currently, the state of the art in design delivers 120Vdc. 200Vac is projected for the next 15 years and 5000Vac is project for 2030.<sup>73</sup> At high power levels, propulsion needs at a minimum 10,000V. Only one design has discussed voltages at this level. Projections for PMAD show that AC, low frequency transmission for 30MWe are more efficient, less massive, and more reliable due to simplicity in design than DC. The specific mass for this system is 1.75kg/kWe.<sup>74</sup> Significant effort and investment must be made in order to achieve this high voltage level from the current state of the art.

---

<sup>73</sup> Lee S. Mason, "A Comparison of Brayton and Stirling Space Nuclear Power Systems for Power Levels from 1 Kilowatt to 10 Megawatts", STAIF, February 2001, Albuquerque, NM,4.

<sup>74</sup> Kenneth J. Metcalf, "Power Conditioning System Modelling (sic) for Nuclear Electric Propulsion" (Canoga Park, CA: NASA -CR-191136, 1993) 4.

#### 4. Launch and Assembly Safety

One of the most important aspects of space nuclear power, safety, is one of the least written about. The safe placement of the reactor in space and the safe assembly of the exploration vehicle while in space pose the highest concern of policy makers and the public. The PeBR design addresses safety more than other designs, and the flexibility of the design allows for the fuel to be launched separately from the vehicle. Fueling a terrestrial reactor is a very difficult process. In space fueling might prove to be more difficult than actual terrestrial planning for a safe launch. Reliable launch vehicles are always a concern due to the expense of the payload. No launch vehicle can be considered 100% reliable; therefore, safety factors must be designed in the power system to either contain all fuel or to have the fuel burn up in re-entry. Re-entry burnup would not be sufficient if the launch vehicle did not make it to orbit. Typically poison plugs have been put in place in the reactor to remove the chance of a water submersion accident. SP-100 was designed to remain intact upon reentry.

The two RTGs lost in the American space program did not release any radioactivity to the environment. Two Russian nuclear powered spacecraft re-entered the atmosphere. One landed in Canada on January 24, 1978. Named Cosmos 954, it scattered radioactive debris in an uninhabited area. One piece of Cosmos 954 gave off 200 roegentens/hour, enough to kill a human in two hours.<sup>75</sup> Cosmos 1402 fell in the Indian Ocean south of Diego Garcia on January 23, 1983. Even more recently reported, the Russian RORSATs leaked 360 pounds of NaK coolant in a 900km orbit, posing a space debris hazard.<sup>76</sup> These hazards if replicated with a MW sized reactor could be catastrophic to a populated city or to the safety of an entire orbit of satellites. Safety needs to be engineered in the initial design and throughout the design of the operations.

---

<sup>75</sup> Space.com, "Falling on a City Near You: Dangerous Space Reentries" [http://www.space.com/news/spacehistory/dangerous\\_reentries\\_000602.html](http://www.space.com/news/spacehistory/dangerous_reentries_000602.html). (accessed November 23, 2004).

<sup>76</sup> Space.com, "Havoc in the Heavens: Soviet Era Satellite's Leaky Reactor's Lethal Legacy" [http://www.space.com/news/mystery\\_monday\\_040329.html](http://www.space.com/news/mystery_monday_040329.html) (accessed November 23, 2004).

## **5. Attitude Determination and Control System**

Unless the satellite is a tumbler, it has an ADCS. With space nuclear power, there is typically a boom or truss structure involved due to the radiation emitted from the reactor. Large truss structures require complicated ADCSs. Many designs lack mention of how these large structures are going to stay pointed in their intended direction of motion. The cost benefit analysis will have to be done in order to decide whether a large control moment gyro (CMG), large flywheel system, or thrust vector control (TVC) will be used. With truss structures reaching 50 feet or more, ADCS needs to be a large part in the design of the system.

## **6. Shield Requirements in Case of a Necessary Extra-Vehicular Activity (EVA)**

Even though not discussed, most reactor designs for space do not expect any maintenance to be performed on them once critical. However, the rest of the ship might not have that requirement. The shadow of the shield needs to take in consideration the areas humans, or other radiation susceptible equipment, might have to move in to perform its mission. For example, if the reactor and the habitability module were in an axial position relative to one another then there would probably be no problem. If there are multiple reactors placed around the habitability module, the module should fit in the shadow of all of the reactors. Any other spacecraft which dock with the exploration vehicle must also fit within that shadow or only be docked for a short period of time.

## **7. Artificial Gravity**

Artificial gravity (AG) is commonly discussed among long duration spaceflight, because long duration space flight has been shown to reduce bone density. AG has the benefits of astronaut health and ease of testing for reactor components. However, part of the ship must be despun in order to provide stable propulsion or vehicle rendezvous. The difficulty with AG is not in the design of how it will be accomplished (nominally 4rpm and a 50m boom). It is in its operation. If the reactor is designed to operate in 1g as a counterweight to the habitability module then what happens when the vehicle must be despun to off load the astronauts? Or if the power system is despun and operating in zero gravity how do you distribute power over that rotary joint? Large space slip rings? Because these engineering challenges are not trivial and AG is not mandatory for a Mars

mission (if the transit times are kept reasonable), AG should not be incorporated in the first manned mission but only on subsequent missions once an NEP transportation system has been proven.

## IV. THUMBRULES AND ASSUMPTIONS FOR NUCLEAR POWER SYSTEMS DESIGN 1MWE-15MWE

Because no multimegawatt power systems have been built, it is difficult to plan a Mars mission accurately. The most likely power system requirement for a manned Mars mission is going to be in the 8-15MWe range, probably split into two or three reactors of 3-5MWe. This section will go through the assumptions and the calculations for a first order estimate of a power system in this range. This is a first cut or SMAD (Space Mission Analysis and Design)-like estimation for a multimegawatt power system. Thumbrules and assumptions all change when different power levels are discussed. The power level groups include 0-100kWe, 100kWe-1MWe, 1MWe-10MWe, and 10MWe and higher. This example will use 4MWe.

### A. NUCLEAR SUBSYSTEM

#### 1. Reactor

For the reactor the following assumptions must be made.

- Fast neutron spectrum
- U235 fuel, enriched >93%
- Liquid metal cooled
- 6% at burnup
- 7 year lifetime at full power

Most of these assumptions are based on SP-100 design. The 6% at burnup is the design specification of UN from BWX technologies, the maker of the fuel. Since this is an approximation, uranium oxide and carbide might also be used but will most likely be a little larger. For power systems in the 1-100kWe range, an empirical formula used is  $M_{Rx}(kg) = 132 * \ln P_{Rx}(kW) - 325$ .<sup>77</sup> This uses thermoelectrics and lower powered CBC designs which are more applicable for that power range. Using the same empirical philosophy the following graph shows the plot and formula for the 1-10MWe range using CBC or Rankine cycle.

---

<sup>77</sup> Mohammed El Genk, STAIF, short course notes, Albuquerque, NM, February 2004

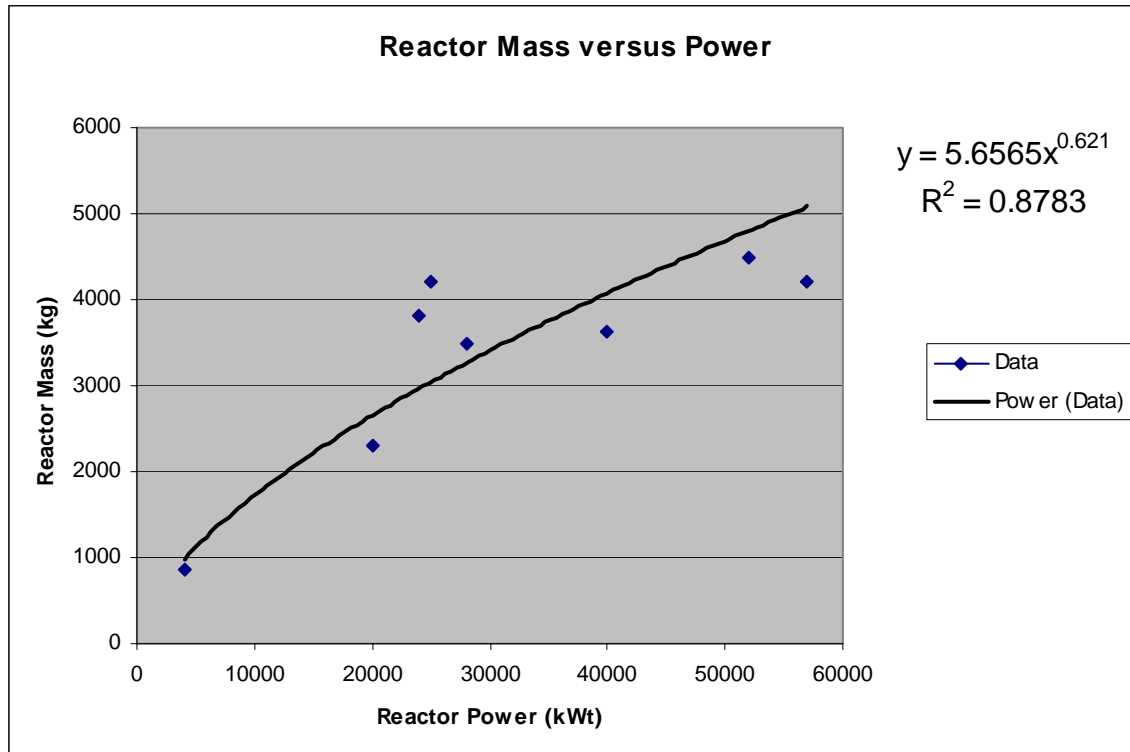

Figure 26. Reactor Mass versus Thermal Power Output for 1-10 MWe Reactor Plants

Using a 17.5% overall efficiency assumption will require a reactor with a 22.86MWt output in order to get 4MWe from it. Therefore, using this formula the reactor mass will be 2880.8kg.

## 2. Shielding

For shielding, the relationships among the powers above 100kWe remain consistent with those below. The following assumptions are also made.

- 7 years nominal power
- Shield cone angle between 30 and 34 degrees
- Payload distance is 20m
- Fast neutron fluence is  $10^{13} \text{ n / cm}^2$
- Gamma dose is 0.5Mrad

These assumptions are also mostly SP-100 based. Using the empirically derived formula,  $M_{SH} (kg) = 26.5 * [P_{Rx} (kW)]^{0.46178}$ , the mass of a shield for a 22.86MWt core is 2708.8kg.

## B. POWER CONVERSION SUBSYSTEM

The type of power conversion chosen will decide which thumbrules are used. For this power range only dynamic power conversion is suitable. Within dynamic, Stirling scales well only to 168kWe; therefore, KRS and CBC were the only two considered. The following table was drawn from Figure 19.

KRS			CBC	
Temperature	Efficiency		Temperature	Efficiency
1000	11		1000	16.5
1100	13.5		1100	20
1200	15.5		1200	24
1300	17		1300	25
1400	18		1400	26
1500	20		1500	26.5
1600	21		1600	27
1700	21		1700	27.5
1800	21		1800	27.5

Table 11. Temperature and Efficiency Values for KRS and CBC Conversion Systems

Using a temperature of 1350K we used a KRS system conversion efficiency of 17.5%. 1350K came from the SP-100 program. This efficiency allows us to find the thermal power requirement as well as the amount of heat rejected by the radiator. Figure 20. above gives us an estimated value of a system specific mass for the overall system but can also be used for the power conversion system only. Assuming a 4kg/kWe value for KRS and a 5kg/kWe value for CBC for systems over 1MWe we can estimate the conversion system mass. For our 4MWe example this equates to a 16000kg system.

## C. HEAT REJECTION SUBSYSTEM

The radiator assumptions include

- Carbon/carbon, liquid metal, heat pipe radiator

---

<sup>78</sup> Mohammed El Genk, STAIF, short course notes, Albuquerque, NM, February 2004

- An emissivity of 0.85

Using the Stephan-Boltzman relationship the following table was produced.

Temperature (K)	kW/m <sup>2</sup>
600	6.25
650	8.60
700	11.57
750	15.25
800	19.74
850	25.16
900	31.62
950	39.26
1000	48.20
1050	58.58
1100	70.56

Table 12. Radiator Temperature and Power per Square Meter Emitted

For our example of 4MWe, 18.86MW must be radiated to space. If we use a radiator temperature of 800K (low estimate, yet demonstrated from SP-100<sup>79</sup>), then we must have 955.28 m<sup>2</sup> of radiator. At around 6kg/m<sup>2</sup><sup>80</sup> this equates to 5731.7kg.

#### D. SPECIFIC MASS

##### 1. Specific Mass Breakdown by Thumbrule Approximation

4 MWe System Estimation (kg)	
Reactor	2880.8
Shield	2708.8
Power Conversion	16000
Heat Rejection	5731.7
Total	27321.3
Structure-10% of Total	2732.13
Total Mass	30053.43
Specific Mass (kg/kWe)	7.51

Table 13. Mass Estimation of 4MWe System

As seen in the above table, the breakdown of a 4MWe power system totals up to 30mT (metric ton). For planning purposes this allows a decision maker to see that this type of power system will not fit with current launch technology or give a better estimate

<sup>79</sup> SP-100 Projected Integration Meeting, General Electric, Long Beach, CA July 19-21, 1988.

<sup>80</sup>“Ultra High Power Space Nuclear Power System Design and Development” Rockwell International, March 2001, NASA CR 2001-210767, 85.

of IMLEO requirements. Of course, this estimate is a conservative one. Using the same methodology a KRS with an in core temperature of 1600K and radiator temperature of 1100K comes out to be 23,402kg with a specific mass of 5.85 kg/kWe. This system could fit in the shuttle bay or Delta IV heavy.

## 2. Empirical Method of Determining Specific Mass

In the preceding parts of this paper many specific masses have been presented. As an overview the following figure combines them all.

Design	Specific Mass(kg/kWe)
UNM Pellet Bed Reactor	3.29
NASA NEP design	10.38
Rocketdyne KRS	4.01
ORNL KRS	4.90
SP-100 Derived-KRS	9.00
SP-100 Derived-CBC	14.00
Calculated Example	7.51

Figure 27. Specific Masses Comparatively

As can be seen the designs vary between 3.29-14 kg/kWe. This is a very large difference. For mission planners this large distribution is unacceptable. In order to reduce this uncertainty, I put together a database (Appendix 3) of every space nuclear power design flown or used as a study. The designs had to be a fission source using U235 as the fuel. With these ninety-five designs the following graph was made.

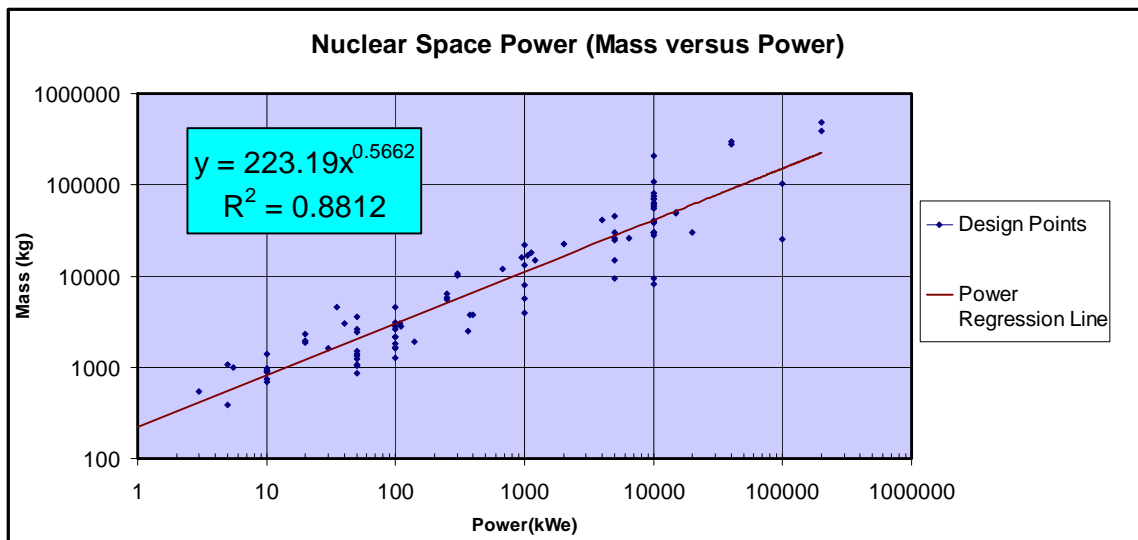

Figure 28. Graph of Space Nuclear Power Design's Mass versus Power (log-log)

The data was fit to varying types of regression lines. The power curve, shown above, fit the best with the highest  $R^2$  value. By using this formula, first order estimates of specific mass can be made quickly. For the 4MWe example, the mass would be 24.44mT equating to a specific mass of 6.11kg/kWe.

## **E. MASS REDUCTION**

As can be seen by the previous estimates, a high energy space reactor power system will have a large mass. There are many ways in which the mass of the reactor can be lowered. The two highest impact components are the shielding and power conversion system.

### **1. Shield Mass Reduction**

The shield can weigh up to a third of the total system mass. There are two methods of lowering shield mass. One is to reduce the thickness of the lithium hydride and tungsten. This could be accomplished by lowering the shielding requirement for the equipment while optimizing the astronaut shield for cosmic radiation and truss length. This would require an integrated power system, habitat module design. Larger truss structures with more axial strength would make it possible to further the distance the power system is from the rest of the spacecraft. Increasing the distance would reduce the thickness of the shielding required to protect the spacecraft from the ionizing radiation produced from the reactor. This is under the assumption that the truss structure separating the payload from the power system has less mass than the reduction in shielding benefit.

### **2. Increasing Power Conversion Efficiency**

The other engineering solution to reducing overall power system mass is to find new power conversion schemes which would increase the power conversion efficiency and reduce the radiator mass required. A higher efficiency would also reduce the amount of nuclear fuel required for a given power level. A lower reactor mass would reduce shield mass requirements and truss structure.

#### ***a. Thermal Photovoltaics***

Direct energy conversion techniques have been the only flown systems to date. The benefits of direct energy conversion have been addressed in the preceding

sections. With static energy conversion, the benefits do not outweigh the low conversion efficiency in the 1-10MWe range. The mass of the power systems and the radiators become unwieldy.

A new static energy conversion system, thermal photovoltaics (TPV), converts heat energy  $>0.5\text{eV}$  into electrical energy. These cells operate in the band where reactors reject heat the most, increasing the potential conversion efficiency of the system to possibly 40%. TPVs are constructed of low band-gap semiconductor materials, such as Indium Gallium Arsenide, which materially are not stable at high temperatures. This poses the problem of maintaining TPV cells at or below 500K. As discussed earlier the temperature at which the radiator radiates dramatically impacts the amount of power per area radiated from the surface. Therefore, TPV conversion systems will require a larger radiator than used with dynamic conversion schemes. Overall system masses can be reduced by using TPV; however, increased development in radiator technologies would be required to make TPV an effective power conversion scheme.<sup>81</sup>

### **3. Increasing Operating Temperatures**

As temperatures are increased in the fuel, temperatures increase at the outlet of the reactor. Depending on the heat rejection temperature, this might increase the temperature drop across the power conversion system and the heat rejection temperature. Both of these will increase the efficiency of their respective units. However, above 1550K there are tradeoffs which must be thoroughly examined before increased performance can be claimed.

The material selection process in the power system is greatly influenced by the operating temperatures of each system. At temperatures above 1550K, the masses of both the primary system and the boiler system (in a KRS) increase due to having to thicken the tantalum alloy component parts due to weaknesses at the higher temperature. The increased performance benefits of the subsystem components do not outweigh these mass increases.<sup>82</sup> Material advances must be made in order to achieve higher than 4kg/kWe which will require higher temperatures.

---

<sup>81</sup> Personal conversation with LT Andrew Presby

<sup>82</sup> "Ultra High Power Space Nuclear Power System Design and Development" Rockwell International, March 2001, NASA CR 2001-210767, 11.

#### **4. Turbine Material Advances**

Because of the high temperature potassium which drives the KRS, refractory alloys are selected to increase the system's reliability. With advances in ceramic turbine blades in the aerospace community, the nuclear space community could benefit. By replacing as many components in the Rankine and Brayton turbines with high temperature ceramic materials a mass savings can be realized.<sup>83</sup>

#### **5. Overall Material Advances**

With the advances in carbon/carbon (c/c) technology, it is possible to use c/c with an alloy layer in the primary piping, boiler/reheater, and KRS's potassium vapor and liquid piping. This would replace refractory alloys typically used such as T-111, ASTAR-811C and Nb-1Zr, which are heavier. If c/c is used in this manner 3000kg could be reduced from the overall system mass of a 10MWe system.<sup>84</sup>

#### **6. Advanced Radiator Concepts**

Heat pipe radiators are the most proven heat rejection system for large amounts of heat dissipation. At the average heat rejection temperatures slightly below 1000K and an emissivity of 0.85, power rejected per square meter is less than 48kW. This makes high power systems require extremely large radiator areas (1000K and an emissivity of 0.85 are state of the art). To reduce radiator area, the power conversion efficiency must be increased or the radiator capabilities must be increased.

In addition to increasing the amount of heat rejected per square kilometer, better coatings with higher emissivities need to be developed. Advanced radiator designs not only decrease the specific mass of current technology systems, but also allow future developments, such as TPV, to be more effective. As discussed earlier, the liquid droplet radiator and the pumped loop radiator are two different candidates. Neither of these candidates is above a TRL 2 and requires substantial RDT&E before they can be a credible option to current heat pipe technology.

---

<sup>83</sup> Rockwell, 28.

<sup>84</sup> Rockwell, 26.

## V. COMPARISON AND RECOMMENDATIONS

### 1. Early Decisions and Project Prometheus

To this point each of the major subsystems of a space nuclear power system (except for Power Management and Distribution) has been presented. Each subsystem's modus operandi, advantages, and disadvantages have been presented. The decision to send a nuclear fission source in space is large and complex regardless of the mission requirements and intended use. Because funding is limited, all aspects of different types of fuels, shielding, heat rejection, and power conversion techniques cannot be explored with financial backing simultaneously. Therefore, the largest decisions will be made early in the program and must be made correctly or the entire program may be cancelled.

The first reactor to be produced to go in space is under Project Prometheus for the Jupiter Icy Moons Orbiter, JIMO. The technologies developed and implemented for Prometheus will be the basis for the development of a multimegawatt power system for future manned exploration. Also, the technologies for the lunar surface reactor and/or surface Mars reactor will also take from Prometheus' experiences. Thus, the decisions made for Prometheus will certainly influence the future direction of space nuclear power for many decades to come. Without understanding the implications of these early decisions will undoubtedly cause many problems for future engineers and policy makers.

Correctly, Project Prometheus has chosen to focus on safety as a first priority.<sup>85</sup> The requirements as dictated by NASA seem very similar SP-100 requirements. In doing this they have allowed themselves to use the large amount of data, analysis, and testing from this program. Because the requirements are similar, the technical roadmaps should begin with the following parameters:

- Uranium Nitride Fuel
- Liquid Metal Cooled Reactor
- Tungsten/Lithium-Hydride Shield
- Carbon/Carbon Liquid Metal Heat Pipe Radiator
- Static Power Conversion

---

<sup>85</sup>NASA, *Project Prometheus*, <http://exploration.nasa.gov/programs/prometheus.html> (accessed October 1, 2004)

- Complete system deployable by Shuttle or Delta IVH

By using these parameters, Prometheus not only uses the base of knowledge developed as part of SP-100 but also sets the stage for larger power systems in the future. The one exception is the power conversion system. For the large MMW class power systems, a dynamic power conversion scheme is necessary. In this area, two options will have to be simultaneously developed. For the lower power systems, the penalties of static conversion (low efficiencies, large radiator mass) can be overlooked for the benefits (simpler design, higher reliability, no AC/DC conversion). For the larger power systems a dynamic power conversion scheme must be invested in. Potassium Rankine provides the highest conversion efficiency with the lowest mass. There is extensive research in the field. Rankine systems have been used in Navy ships and submarines for many years. With the low powered system being liquid metal cooled, a KRS could be implemented in place of a static conversion system with limited design changes in other subsystems.

## **2. Recommendations on Viable Multimegawatt Designs**

Many paper reactors can take incredible liberties in their base assumptions. Without intense scrutiny, these details slip through the cracks and an impossible engineering reality seems realistic. The following conditions should raise flags in consideration of building a space nuclear power system.

- Specific mass below 4kg/kWe
- Operating temperatures near or above 1550K<sup>86</sup>
- Liquid Droplet Radiators
- Radiators specifications below 5kg/m<sup>2</sup>
- Systems with no mention of launch safety
- Systems greater than 20mT with no discussion of in orbit construction or new launch vehicle development
- Shield designs without discussion of boom length
- Truss design without mention of ADCS
- Stirling power conversion above 200kWe
- No discussion of refractory element usage

---

<sup>86</sup> Rockwell, 118.

- Greater than 8% at burnup in fast spectrum reactors<sup>87</sup>
- Reactor restart capability
- Backup power sources

Many system design improvements could have tremendous positive impacts on the performance of a space nuclear power system; however, first a power system greater than 100kWe must be flown. Once the power system is shown safe and operational, these new technologies should be funded and developed to further advance the program.

### **3. Recommendations on Technology Investment Decisions**

Commonly in program management higher risk technologies will be bought down with early funding for research and development. The following areas require immediate funding today for future space missions:

- Nuclear fuels development, production, and irradiation testing
- Heavy Lift Launch Vehicle (HLLV) development
- Refractory alloy manufacture, production, and irradiation and creep testing.
- Potassium Rankine duration testing
- Long duration, high power, electric propulsion development and testing

Uranium Nitride was the fuel of choice for the SP-100 project and can be used in a multitude of reactor designs. A lot of developing has already occurred; yet large scale production is not possible today. An early investment in fuels will allow the reactor neutronics and lifetime modeling to be complete and accurate prior to flight.

Launch propulsion is still a large barrier to entry to space. Many reports, including the recent Aldridge report, state that without a serious investment in new launch propulsion systems, the President's vision for space exploration cannot go forward. If the specific power for 4MWe systems is 6.11kg/kWe as is expected, then a complete power system for a manned mission to Mars can be launched in one 80mT payload launch vehicle. A rudimentary calculation proving the viability of using a shuttle derived LO/LH launch vehicle is in the appendix. This sized launch vehicle is mandatory for Moon exploration, Mars exploration, and the upcoming space tourism market.

---

<sup>87</sup> W. J. Carmack, D.L.Husser, T.C.Mohr, and W.C.Richardson, "Status of Fuels Development and Manufacturing for Space Nuclear Reactors at BWX Technologies", STAIF, Albuquerque, NM, February 2004, 426.

Launch vehicle development, even shuttle derived, is a long process. It is expensive, and must be begun today for exploration in the future.

Refractory elements are the backbone for space nuclear power systems. A strong manufacturing, production, and testing facility needs to be built early in the program. The required tests were discussed in the materials section.

Once the materials have been established, the potassium Rankine systems need to be tested for long duration. Many tests were done in the 60's, but not at the power levels required for a manned mission.

Finally, the electric propulsion systems which will send the mission to Mars need to be developed further. Many different EP devices are in development today, but those applicable to a manned mission are only at a TRL 2 or 3. High power, high duration systems need to be funded in parallel with the power system's development in order for unforeseen difficulties which inevitably occur in high technology endeavors to be overcome. A fallback in schedule in one, drastically affects the other.

## VI. CONCLUDING THOUGHTS

A manned mission to Mars has many requirements. The power systems is but one of them. However, without sufficient available power, the mission will have to sacrifice safety, reliability, and flexibility in order to launch. Without newly developed heavy lift launch vehicles no manned Mars missions will occur.

When planning for a long duration manned space mission, a practical planning factor is specific mass. For a nuclear electric power system this value changes based on different types of subsystems chosen. The bracket of possible values is 4-8 kg/kWe using state of the art technology and at least a twenty year timeline. Using a KRS system with c/c heat pipe radiators, and a UN pin type fuel an approximate specific mass of 6-7 kg/kWe is achievable under the same circumstances. Without investment in the pertinent technologies, these values will remain the same no matter the year.

Material advances in fuels and refractory metals as well as coated c/c will increase reliability and lower specific mass. Stronger, lighter materials will allow for higher temperatures, which will increase efficiencies and lower radiator masses. Advances in static energy conversion sources have the long term potential to revolutionize space nuclear power and make dynamic conversion obsolete.

Mars needs to be explored by humans present on the surface. Realistic people in the 1970s believed that by the year 2000, more people who have walked on the moon would be permanently on Mars. Every night when people see the moon they realize that it is possible to walk its surface. Humans have the endurance and the knowledge to widen their frontier beyond the moon. With a national commitment to join together and accomplish this ever present challenge, America can once again shine from the highest hill as a beacon of human potential and imagination.

THIS PAGE INTENTIONALLY LEFT BLANK

## APPENDICIES

### 1. MARS MISSIONS PAST, PRESENT, AND FUTURE

Mission	Country	Launch	Purpose	Results
[Unnamed]	USSR	10/10/1960	Mars flyby	did not reach Earth orbit
[Unnamed]	USSR	10/14/1960	Mars flyby	did not reach Earth orbit
[Unnamed]	USSR	10/24/1962	Mars flyby	achieved Earth orbit only
Mars 1	USSR	11/1/1962	Mars flyby	radio failed at 65.9 million miles (106 million km)
[Unnamed]	USSR	11/4/1962	Mars flyby	achieved Earth orbit only
Mariner 3	U.S.	11/5/1964	Mars flyby	shroud failed to jettison
Mariner 4	U.S.	11/28/1964	first successful Mars flyby 7/14/65	returned 21 photos
Zond 2	USSR	11/30/1964	Mars flyby	passed Mars but radio failed, returned no planetary data
Mariner 6	U.S.	2/24/1969	Mars flyby 7/31/69	returned 75 photos
Mariner 7	U.S.	3/27/1969	Mars flyby 8/5/69	returned 126 photos
Mariner 8	U.S.	5/8/1971	Mars orbiter	failed during launch
Kosmos 419	USSR	5/10/1971	Mars lander	achieved Earth orbit only
Mars 2	USSR	5/19/1971	Mars orbiter/lander arrived 11/27/71	no useful data, lander destroyed
Mars 3	USSR	5/28/1971	Mars orbiter/lander, arrived 12/3/71	some data and few photos
Mariner 9	U.S.	5/30/1971	Mars orbiter, in orbit 11/13/71 to 10/27/72	returned 7,329 photos
Mars 4	USSR	7/21/1973	failed Mars orbiter	flew past Mars 2/10/74
Mars 5	USSR	7/25/1973	Mars orbiter, arrived 2/12/74	lasted a few days
Mars 6	USSR	8/5/1973	Mars orbiter/lander, arrived 3/12/74	little data return
Mars 7	USSR	8/9/1973	Mars orbiter/lander, arrived 3/9/74	little data return
Viking 1	U.S.	8/20/1975	Mars orbiter/lander, orbit 6/19/76-1980, lander 7/20/76-1982	Combined, the Viking orbiters and landers returned 50,000+ photos
Viking 2	U.S.	9/9/1975	Mars orbiter/lander, orbit 8/7/76-1987, lander 9/3/76-1980	combined, the Viking orbiters and landers returned 50,000+ photos
Phobos 1	USSR	7/7/1988	Mars/Phobos orbiter/lander	lost 8/88 en route to Mars
Phobos 2	USSR	7/12/1988	Mars/Phobos orbiter/lander	lost 3/89 near Phobos
Mars Observer	U.S.	9/25/1992	orbiter	lost just before Mars arrival 8/21/93
Mars Global Surveyor	U.S.	11/7/1996	orbiter, arrived 9/12/97	currently conducting prime mission of science mapping
Mars 96	Russia	11/16/1996	orbiter and landers	launch vehicle failed
Mars Pathfinder	U.S.	12/4/1996	Mars lander and rover, landed 7/4/97	last transmission 9/27/97
Nozomi (Planet-B)	Japan	7/4/1998	Mars orbiter, currently in orbit around the Sun	Mars arrival delayed to 12/03 due to propulsion problem
Mars Climate Orbiter	U.S.	12/11/1998	Orbiter	lost on arrival at Mars 9/23/99
Mars Polar Lander/Deep Space 2	U.S.	1/3/1999	lander/descent probes to explore Martian south pole	lost on arrival 12/3/99
Mars Odyssey	U.S.	4/7/2001	Orbiter	currently conducting prime mission of science mapping
Mars Express	E.S.A.	6/2/2003	Orbiter and Lander	lander Beagle 2 failed, orbiter conducting prime mission of science mapping
Mars Exploration Rovers	U.S.	6/10/2003	Rover	currently roving Mars
Mars Exploration Rovers	U.S.	7/7/2003	Rover	currently roving Mars
Mars Reconnaissance Orbiter	U.S.	8/2005	Orbiter	Planned
Phoenix	U.S.	8/2007	Mars Lander	Planned
Mars Science Laboratory	U.S.	2009	Mars Lander (proposal)	Planned
Sample Return Mission	U.S.	2014	Mars Lander (proposal)	Planned

Table 14. Mars Missions Past, Present, and Future<sup>88</sup>

<sup>88</sup> <http://mars.jpl.nasa.gov/missions/> (accessed November 29, 2004)

## 2. LAUNCH VEHICLE TO LEO COMPUTATION

Currently, the world's launch vehicle market has the capability to place approximately 25mT of payload in LEO. For a manned mission to Mars this is an inadequate lift capability. As sighted in NASA's Mars Design Reference Mission (DRM) addendum to version 3, the probable need of a Mars mission will be around an 80mT lift capability. For reference, the Saturn V launch vehicle lifted 118mT to 185km orbit.<sup>89</sup> As sighted by the Aldridge Commission, "we have been particularly concerned that NASA pay close attention early to assessing options for a new heavy-lift space launch capability."<sup>90</sup> A new heavy lift launch vehicle needs to be developed in order for a manned mission beyond LEO to take place.

Many papers have sighted the difficulty in trying to rebuild a Saturn V rocket. Because the past two decades have been shuttle centric, we should focus on the existing hardware, testing facilities, and storage capabilities NASA already has in place. The DRM relies on a shuttle derived, liquid hydrogen/liquid oxygen (LH/LOX) launch vehicle, named the Magnum. Many variants exist, but they all center on a large LH tank with a LOX tank above. The variants include using Shuttle Solid Rocket Boosters (SRB) with two RS-68s, three RS-68s with a smaller core, three and four RD0120 with varying cores. A more advanced version uses two Liquid Flyback Boosters instead of SRBs. Variants of this are the "baseline" with two RS-68s, a LOX/RP1 with five RD180s, and a LOX/LH with three RD0120s.

Understanding that the entire Mars mission depends upon the successful construction of a HLLV, the following calculations show through simple means that an 80mT vehicle using shuttle hardware is feasible. All of the calculations use formulas and tables from Rocket Propulsion Elements (RPE) by Sutton and Biblarz.

---

<sup>89</sup>Astronautix, *Saturn V*, <http://www.astronautix.com/lvs/saturnv.htm>, (accessed October 17, 2004)

<sup>90</sup>Aldridge Commission Report, 2004, 27.

## Magnum Launch Vehicle

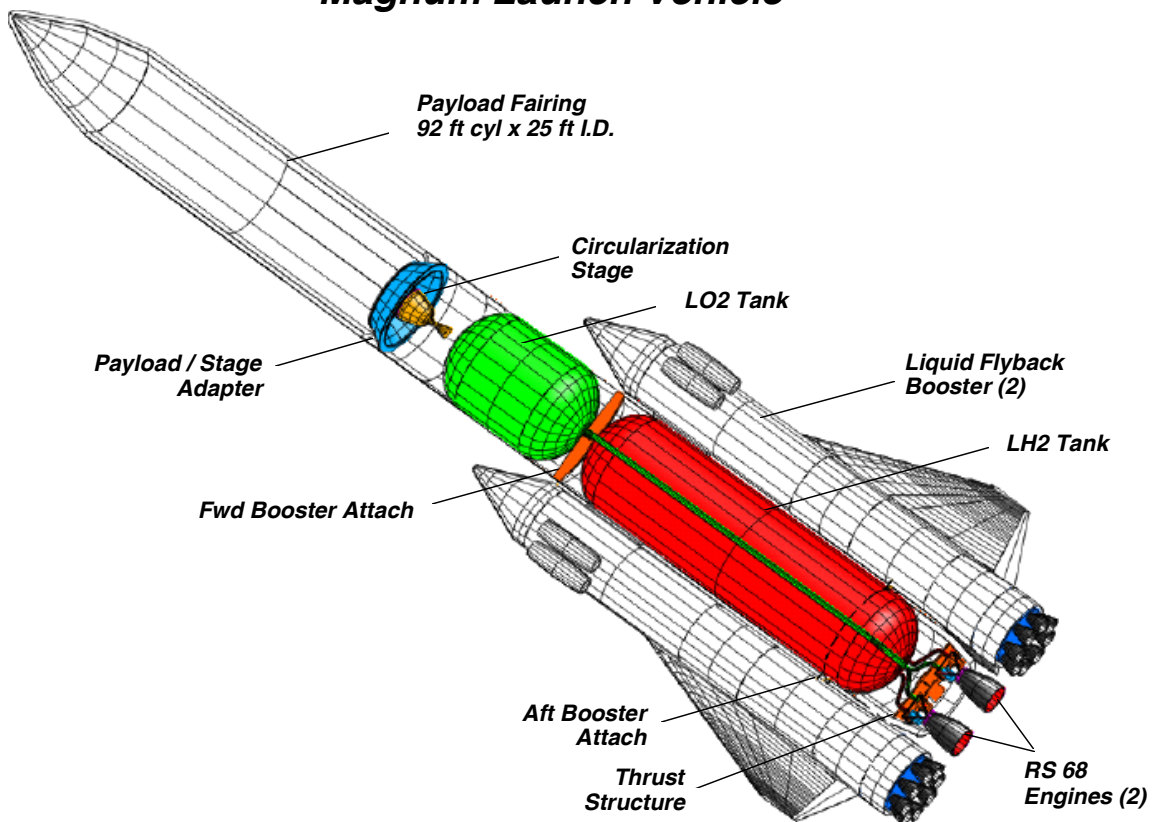

Figure 29. Magnum Launch Vehicle as Proposed in NASA's DRM

**Assumption one:** 80mT payload=176,400 lbm  
**Assumption two:** Desired velocity increase = 9347 m/sec  
 (using Shuttle velocity breakdown Table 4-3)  
 Orbit altitude = 110km  
 Max stage diameter = 8.4 m enables HLLV to use Shuttle facilities  
 Max acceleration = 3 g<sub>o</sub> for manned mission

**Assumption three:** Fuel is LH with LOX oxidizer (From Table 5-5(frozen flow))

Mass ratio=3.4  
 Average Specific gravity=0.26  
 Chamber Temp=2959K  
 Characteristic velocity=2428m/sec  
 Molecular Mass of combined products=8.9  
 Specific Impulse (I<sub>s</sub>) = 386 seconds  
 k=1.26

LH makes for excellent regenerative cooling.

**Assumption four:** Using RS-68 engines  
 Chamber pressure=95.92bar=1410psia=9.592MPa  
 Nozzle area ratio:  $D_t=19.22''$  <sup>91</sup> ;  $\epsilon = \frac{A_2}{A_t} = 21.5$

Per RPE, the specific impulse of LH/LOX at 40% between frozen and shifting = 387.4 sec. However, the RS-68 is less efficient and has a specific impulse of 362 at sea level.

**Assumption five:**  $p_2=p_3=14.7\text{psia}=0.101325\text{MPa}$  (at sea level)  
 using  $p_1/p_3=94.67$  we get  $C_f=1.6$  (From Figure 3-7)

The chamber pressure is set high and the thrust chamber is small in order to save vehicle space and inert mass. The feed system will need to be more robust than the current shuttle system in order to take the higher pressures. The HLLV will use two RS-68s, instead of three Space Shuttle Main Engines (SSME), due to their simplified design philosophy which uses less parts.<sup>92</sup> (Use page 386, Table 10-3) The configurations give about the same thrust, yet the Is of the SSME is better.

Starting with calculating the mass flow rate of the RS-68s at sea level:

$$F = A_t C_F p_1$$

$$F = \left( \frac{19.22''}{2} \right)^2 * \pi * 1.6 * 1410$$

$$F = 6.54 * 10^5 \text{ lb}_f = 2.91 * 10^6 \text{ N}$$

Using the thrust, the mass flow rate of the engine:

$$\dot{m}_{RS-68} = \frac{F}{g_0 I_s} = \frac{2.91 * 10^6 \text{ N}}{9.81 \text{ m/s}^2 * 362 \text{ s}} = 819.19 \text{ kg/s}$$

---

<sup>91</sup> Drake, R. personal phone conversation on RS-68 specifications.

<sup>92</sup> Sutton and Biblarz, Rocket Propulsion Elements, p.324.

**Assumption six:** SRB Is = 237s  
 SRB thrust =  $2.6 * 10^6 \text{ lb}_f = 1.15 * 10^7 \text{ N}$

$$\dot{m}_{SRB} = \frac{F}{g_0 I_s} = \frac{1.15 * 10^7 \text{ N}}{9.81 \text{ m/s}^2 * 237 \text{ s}} = 4946.3 \text{ kg/s}$$

With the mass flow rates of each stage we can begin to calculate the  $\Delta u$  this rocket will produce. The simplest Magnum has two RS-68s and two Shuttle SRBs. With this assumption, the low specific impulse of the SRBs will lower the initial stage specific impulse. Using a different type of first stage would improve the performance. The initial stage uses the sea level values for specific impulse and the second stage uses the specific impulse in a vacuum.

$$\Delta u = \sum c \ln\left(\frac{m_o}{m_f}\right) = \Delta u_o + \Delta u_1$$

$$\Delta u_{initial-stage} = c_{initial-stage} \ln\left(\frac{m_{o_1}}{m_{f_1}}\right); \Delta u_{second-stage} = c_{second-stage} \ln\left(\frac{m_{o_2}}{m_{f_2}}\right)$$

$$I_{s-initial-stage} = \frac{\sum F}{g_o \sum \dot{m}}$$

$$I_{s-initial-stage} = \frac{2.91 * 10^6 \text{ N} + 1.15 * 10^7 \text{ N}}{9.81(819.19 \text{ kg/s} + 4946.3 \text{ kg/s})} = 254.78 \text{ sec}$$

$$c_{initial-stage} = 9.81 * 254.78 = 2499.35 \text{ m/s}$$

**Assumption seven:** The Shuttle External Tank (ET) will be filled completely with LH and another LOX tank will be part of the upper stage on top of the ET.

$$\text{ET empty} = 66,800 \text{ lb}_m$$

Filling both the LOX and LH tanks of ET with LH

$$\text{LH}_{\text{mass}} = 19,182 \text{ ft}^3 (\text{volume of LOX tank}) * 4.43 \text{ lb}_m / \text{ft}^3 + 237,641 \text{ lb}_m = 322,652 \text{ lb}_m = 1.46 * 10^5 \text{ kg}$$

LOX required with a 5.85 by mass mixture:

$$\text{LOX}_{\text{mass}} = 5.86 * 322,652 \text{ lb}_m = 1.89 * 10^6 \text{ lb}_m = 8.57 * 10^5 \text{ kg}$$

$$\text{LH/LOX}_{\text{mass}} = 2.21 * 10^6 \text{ lb}_m$$

$$\text{SRB}_{\text{mass}} = 1.3 * 10^6 \text{ lb}_m$$

$$\text{SRB}_{\text{fuel-mass}} = 1.1 * 10^6 \text{ lb}_m$$

$$\text{Magnum}_{\text{mass}} = \text{ET}_{\text{empty}} + \text{LH} + \text{LOX} + 2 * \text{SRB} + \text{payload}$$

$$\text{Magnum}_{\text{mass}} = 66,800 + 322,652 + 1.89 * 10^6 + 2 * 1.3 * 10^6 + 176,400$$

$$\text{Magnum}_{\text{mass}} = 5.06 * 10^6 \text{ lb}_m$$

**Assumption eight:** First stage burns for the nominal 124 seconds of the SRBs and then separates.

$$m_{o_1} = 5.06 * 10^6 \text{ lb}_m$$

$$m_{\text{LH/LOXburnt-initial-stage}} = 819.19 \text{ kg} / \text{s} * 2.205 \text{ lb}_m / \text{kg} * 124 \text{ sec} * 2 \text{ engines} = 4.5 * 10^5 \text{ lb}_m$$

$$m_{f_1} = 5.06 * 10^6 \text{ lb}_m - 2 * 1.1 * 10^6 \text{ lb}_m - 4.5 * 10^5 \text{ lb}_m = 2.41 * 10^6 \text{ lb}_m$$

$$\Delta u_{\text{initial-stage}} = 2499.35 \ln\left(\frac{5.06}{2.41}\right) = 1853.87 \text{ m} / \text{s}$$

$$c_{\text{second-stage}} = g_o I_s = 9.81 * 420 = 4120.2 \text{ m} / \text{s}$$

$$m_{o_2} = m_{f_1} - m_{\text{boosterempty}} = 2.41 * 10^6 \text{ lb}_m - 2 * 0.2 * 10^6 \text{ lb}_m = 2.01 * 10^6 \text{ lb}_m$$

$$m_{\text{fuelleftinET}} = 2.21 * 10^6 \text{ lb}_m - 5.06 * 10^5 \text{ lb}_m = 1.704 * 10^6 \text{ lb}_m$$

$$m_{f_2} = 2.01 * 10^6 \text{ lb}_m - 1.704 * 10^6 \text{ lb}_m = 306,000 \text{ lbs}$$

$$\Delta u_1 = 4120.2 * \ln\left(\frac{2.01}{.306}\right) = 7755.5 \text{ m} / \text{s}$$

$$\Delta u = 1853.87 + 7755.5 = 9609.37 \text{ m} / \text{s}$$

If the final mass in orbit is 306,000 lbs minus 66,800 lbs mass of ET and 176,400 lbs for payload and there is 62800lbs remaining. This is due to rounding errors, but would be attributable to unused fuel, payload fairing, connectors, and structural components. The achieved  $\Delta u$  of 9609.37m/s is sufficient to meet the assumed requirement of 9347 m/s for a Shuttle payload. The orbit of 110km would typically not be used for an assembly of a manned Mars vehicle using space nuclear power but an orbit injection phase could be used to place the payload in a safer orbit.

The above calculation shows through rudimentary analysis that a baseline HLLV using existing Shuttle architecture and parts can be used to place an 80mT payload in orbit.

**a. Bibliography for Launch Vehicle Computation**

Reference Mission Version 3.0: Addendum to Human Exploration of Mars: The Reference Mission from the NASA Exploratory Study Team, June 1998.

Borowski, Stanley, NASA Glenn Research Center, personal phone conversation and fax of Magnum specifications from the Space Exploration Program.

Sutton, George and Oscar Biblarz, Rocket Propulsion Elements (New York: John Wiley and Sons, 2001).

<http://mars.jpl.nasa.gov/> (accessed November 26, 2004)

<http://www.astronautix.com> (accessed November 26, 2004)

<http://science.ksc.nasa.gov/shuttle/technology/sts-newsref/srb.html#srb-posts>  
(accessed November 26, 2004)

<http://mars.nw.net/> (accessed November 26, 2004)

<http://www.marssociety.org/> (accessed November 26, 2004)

### 3. EMPIRICAL DATABASE FOR SPECIFIC MASS CALCULATION

Space Nuclear Power Design	Nominal Mass (kilograms)	Nominal Power (kWe)	Specific Power (kWe/kg)	Specific Mass (kg/kWe)
<a href="#">1 MW MPRE</a>	5680	1000	0.18	5.68
<a href="#">10 MW (Turbine)</a>	8136	10000	1.23	0.81
<a href="#">10 MW Potassium-Vapor</a>	54544	10000	0.18	5.45
<a href="#">10 MW STARS</a>	58152	10000	0.17	5.82
<a href="#">140 kW MPRE</a>	1905	140	0.07	13.61
<a href="#">2 MW TFE Concept</a>	22490	2000	0.09	11.25
<a href="#">367 kW MPRE</a>	2510	367	0.15	6.84
<a href="#">5 MW MPRE</a>	25985	5000	0.19	5.20
<a href="#">Bimodal System</a>	1410	10	0.01	141.00
<a href="#">BNL Particle Bed Reactor</a>	40000	10000	0.25	4.00
<a href="#">ENABLER</a>	30000	10000	0.33	3.00
<a href="#">GA In-core Thermionic System</a>	26000	6500	0.25	4.00
<a href="#">Grumman 50 kW</a>	855	50	0.06	17.10
<a href="#">LANL 10 kW Brayton</a>	895	10	0.01	89.50
<a href="#">LANL 10 kW Rankine</a>	960	10	0.01	96.00
<a href="#">LANL 10 kW Stirling</a>	735	10	0.01	73.50
<a href="#">LANL 10 kW TE (UC)</a>	695	10	0.01	69.50
<a href="#">LANL 10 kW TE (UO2)</a>	920	10	0.01	92.00
<a href="#">LANL 10 kW TI</a>	885	10	0.01	88.50
<a href="#">LANL 100 kW Brayton</a>	1800	100	0.06	18.00
<a href="#">LANL 100 kW Rankine</a>	2130	100	0.05	21.30
<a href="#">LANL 100 kW Stirling</a>	2160	100	0.05	21.60
<a href="#">LANL 100 kW TE (UC)</a>	1640	100	0.06	16.40
<a href="#">LANL 100 kW TE (UO2)</a>	1605	100	0.06	16.05
<a href="#">LANL 100 kW TI</a>	1270	100	0.08	12.70
<a href="#">LANL 50 kW Brayton</a>	1315	50	0.04	26.30
<a href="#">LANL 50 kW Rankine</a>	1500	50	0.03	30.00
<a href="#">LANL 50 kW Stirling</a>	1385	50	0.04	27.70
<a href="#">LANL 50 kW TE (UC)</a>	1225	50	0.04	24.50
<a href="#">LANL 50 kW TE (UO2)</a>	1040	50	0.05	20.80
<a href="#">LANL 50 kW TI</a>	1080	50	0.05	21.60
<a href="#">LLNL Nuclear Rankine System</a>	70000	10000	0.14	7.00
<a href="#">NASA 1 MW Brayton</a>	13300	1000	0.08	13.30
<a href="#">NASA 1 MW Stirling</a>	21800	1000	0.05	21.80
<a href="#">NASA 10 MW Brayton</a>	108000	10000	0.09	10.80

<b>Space Nuclear Power Design</b>	<b>Nominal Mass (kilograms)</b>	<b>Nominal Power (kWe)</b>	<b>Specific Power (kWe/kg)</b>	<b>Specific Mass (kg/kWe)</b>
<a href="#">NASA 100 kW Stirling</a>	3100	100	0.03	31.00
<a href="#">RC / MC Thermionic</a>	5595	250	0.04	22.38
<a href="#">RMBLR</a>	30000	20000	0.67	1.50
<a href="#">Rocketdyne K-Rankine System</a>	30000	10000	0.33	3.00
<a href="#">Rockwell UHP 10 MW (10 yr.)</a>	40095	10000	0.25	4.01
<a href="#">Rockwell UHP 10 MW (2 yr.)</a>	30006	10000	0.33	3.00
<a href="#">Rockwell UHP 200 MW (10 yr.)</a>	484749	200000	0.41	2.42
<a href="#">Rockwell UHP 200 MW (2 yr.)</a>	385002	200000	0.52	1.93
<a href="#">RORSAT</a>	390	5	0.01	78.00
<a href="#">SNAP-10A</a>	295	0.533	0.00	553.47
<a href="#">SNAP-2</a>	546	3	0.01	182.00
<a href="#">SNAP-50</a>	10070	300	0.03	33.57
<a href="#">SNAP-8</a>	4545	35	0.01	129.86
<a href="#">SP-100</a>	2800	100	0.04	28.00
<a href="#">SPACE-R</a>	1600	30	0.02	53.33
<a href="#">SPR-4</a>	3750	375	0.10	10.00
<a href="#">SPR-5</a>	60000	10000	0.17	6.00
<a href="#">SPR-6</a>	70000	10000	0.14	7.00
<a href="#">SPR-8 10 MW</a>	80000	10000	0.13	8.00
<a href="#">SPR-9 10 MW</a>	38000	10000	0.26	3.80
<a href="#">Standard MC (U8Ta2C)</a>	5776	250	0.04	23.10
<a href="#">Standard Multi-cell</a>	6440	250	0.04	25.76
<a href="#">Topaz I</a>	1000	5.5	0.01	181.82
<a href="#">Topaz II</a>	1061	5	0.00	212.20
<a href="#">Topaz III</a>	3000	40	0.01	75.00
<a href="#">Torchlite</a>	25000	5000	0.20	5.00
<a href="#">TRW 50 kW</a>	1043	50	0.05	20.86
<a href="#">UNM Pellet Bed -1990</a>	64000	10000	0.16	6.40
<a href="#">UNM Pellet Bed Reactor-1994</a>	49350	15000	0.30	3.29
<a href="#">Boeing NEP VEH</a>	274682	40000	0.15	6.87
<a href="#">High temperature Pin-Fuel Element Reactor with Thermoelectric Conversion(233-Angelo)</a>	2799	110	0.04	25.45
<a href="#">In Core Thermionic Power System(235-Angelo)</a>	2996	108.398	0.04	27.64
<a href="#">Low-Temperature Pin Fule Element Reactor with Stirling Cycle conversion(239-Angelo)</a>	12000	680	0.06	17.65
	17000	1050	0.06	16.19
	15000	1200	0.08	12.50
	16000	950	0.06	16.84

<b>Space Nuclear Power Design</b>	<b>Nominal Mass (kilograms)</b>	<b>Nominal Power (kWe)</b>	<b>Specific Power (kWe/kg)</b>	<b>Specific Mass (kg/kWe)</b>
<a href="#">Potentially Achievable performance for MW systems-Heat Pipe/Stirling (Angelo-268)</a>	3920	1000	0.26	3.92
	9380	5000	0.53	1.88
<a href="#">Candidate Parameters for 10 and 100MWe plants(Angelo-270)</a>	27840	10000	0.36	2.78
	103620	100000	0.97	1.04
	9370	10000	1.07	0.94
	25530	100000	3.92	0.26
<a href="#">Performance goals for MWe class (Angelo-267)</a>	15000	5000	0.33	3.00
	8000	1000	0.13	8.00
<a href="#">300kWe advanced Rankine cycle space power syste (Angelo-201)</a>	10570	300	0.03	35.23
<a href="#">Out of core thermionic reactor operating characteristics (219-Angelo)</a>	3800	400	0.11	9.50
<a href="#">ORNL - MMW-design</a>	30000	5000	0.17	6.00
<a href="#">Lewis research Center-1994-Mars NEP architecture</a>	41510	4000	0.10	10.38
<a href="#">ERATO-UO2</a>	2319	20	0.01	115.95
<a href="#">ERATO-HGTR</a>	1960	20	0.01	98.00
<a href="#">ERATO-UN</a>	1884	20	0.01	94.20
<a href="#">ERATO-UO2</a>	3610	50	0.01	72.20
<a href="#">ERATO-HGTR</a>	2600	50	0.02	52.00
<a href="#">ERATO-UN</a>	2430	50	0.02	48.60
<a href="#">SP-100-scaleable-Rankine</a>	45000	5000	0.11	9.00
<a href="#">SP-100-scaleable-Rankine</a>	75000	10000	0.13	7.50
<a href="#">SP-100-scaleable-Rankine</a>	301930	40000	0.13	7.55
<a href="#">SP-100/SPAR (224-Angelo)</a>	4610	100	0.02	46.10

Figure 30. Database of Space Nuclear Power Designs<sup>93,94</sup>

<sup>93</sup> <http://sei2.sei.aero/ACDB/ACpowDB.asp> (17 Nov 04)

<sup>94</sup> Joseph A. Angelo, Jr. and David Buden, Space Nuclear Power, (Malabar, Florida: Orbit, 1985).

#### 4. MARS MISSION TIMING

##### 1. Ballistic Trajectories

The path of any spacecraft to Mars must follow one of two types of ballistic trajectories: Conjunction and Opposition.

###### *a. Opposition*

Opposition type trajectories are also known as short stay trajectories. They are classified as short stay missions, usually between 20-40 days on the planet. Their return trajectory crosses inside of earth's orbit, within Venus's orbit. Opposition refers to the earth leaving opposition from Mars as the spacecraft reaches Mars, or in other words, the sun is between the earth and Mars at the end of the inbound leg. After the short stay, the earth return vehicle must catch up with the earth in order to catch it, requiring the vehicle to pass inside of earth's heliocentric orbit, giving it the necessary speed. Once near earth the vehicle is too fast and must use more  $\Delta v$  to slow down to enter earth's orbit.

###### Advantages

- Short duration spaceflight (1.6years)

###### Disadvantage

- High  $\Delta v$  mission requirements
- Lower mass fraction
- Shorter time on Mars
- Longer time in zero gravity than currently explored

A variant of the opposition type mission gives a total duration stay on Mars of 60days by performing a swingby of Venus or a  $\Delta v$  maneuver in interplanetary space. This will lower the total required  $\Delta v$  and increase the stay time at Mars.

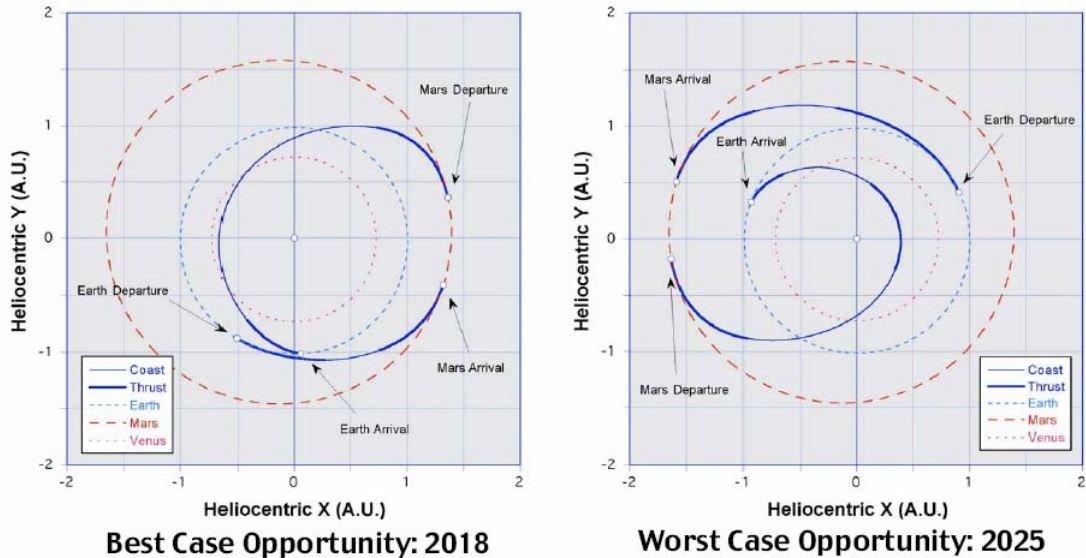

Figure 31. Opposition Class Trajectories

**b. Conjunction**

Conjunction trajectories are also known as long stay trajectories. Conjunction means that at Mars arrival, earth is moving into conjunction with Mars, or in other words the earth and mars are on the same side of the sun. They are characterized by their short outbound and inbound legs, but pay for this short duration flight by a long, usually a year and a half, mission duration on Mars, waiting for the correct alignment. The total trip time is usually around 2.8 years for the lowest energy case.

Advantages

- Low  $\Delta v$  for mission
- Smallest propellant mass for a given propulsion type
- Less time in zero gravity condition
- Less time in high radiation environment

Disadvantage

- Relatively long time for roundtrip flight

If the  $\Delta v$  is increased for a conjunction mission then the trip time in interplanetary space can be reduced to around 120 days as opposed to the 191-235 on a minimum  $\Delta v$  mission.<sup>95</sup> This “fast transit” lowers the total trip time by 100 days to 854days.

<sup>95</sup> Larsen, Wiley J. and Linda Prane, Human Spaceflight, Mission Analysis and Design, McGraw Hill Companies, Inc. San Francisco, p. 258.

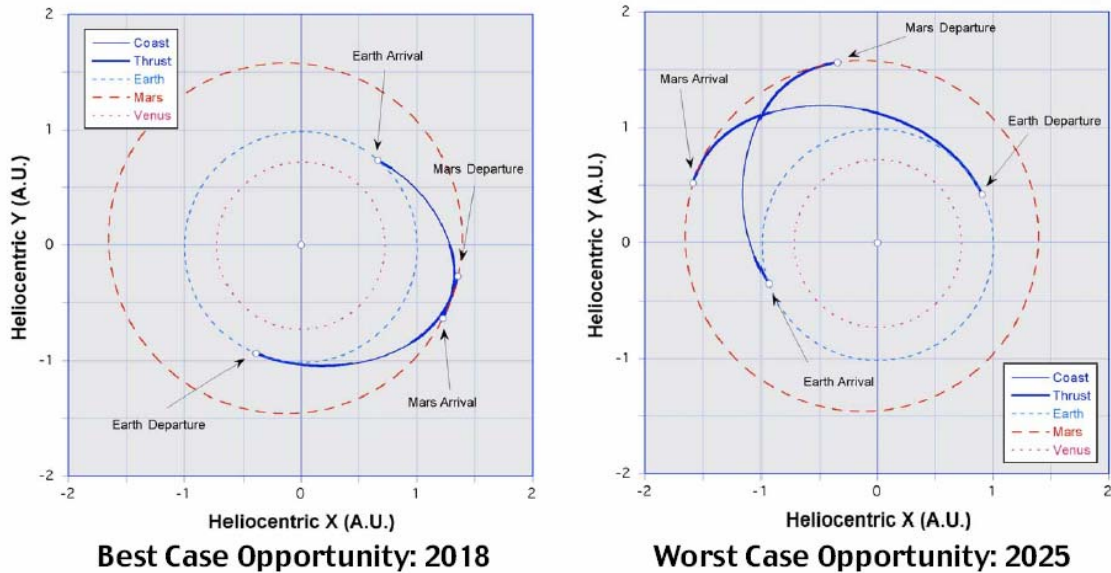

Figure 32. Conjunction Class Trajectories

## 2. Low-Thrust Trajectories

With a NTR or chemical Trans Mars Injection (TMI) stage, the specific impulse is constant. The thruster lights off and the spacecraft flies towards its target. This limits the trajectory selection to the previous ballistic ones. With a Variable Specific Impulse Magneto-plasma Rocket or VASIMR, the Isp can be scaled to optimize the performance of the vehicle at every stage of the expedition. Figure 32 is representative of a low thrust trajectory.

The low thrust trajectory includes a spiraling out from LEO to the edge of the earth's gravity well, where the crew will meet up with the vehicle. The vehicle thrusts towards Mars for around six months and begins the spiral in towards Low Mars Orbit (LMO). Mars stays range from 100-200 days and the total trip time average 2.5 years. Many variations exist on this trajectory, but all are different based on the thruster's characteristics.<sup>96</sup>

### Advantages

- More abort scenarios

<sup>96</sup> Larsen, Wiley J. and Linda Prane, Human Spaceflight, Mission Analysis and Design, McGraw Hill Companies, Inc. San Francisco, p. 260,261.

- Lower propellant-mass requirements, due to higher Isp
- Disadvantage
- Spiral out maneuver requires autonomous vehicle control
  - More complicated vehicle

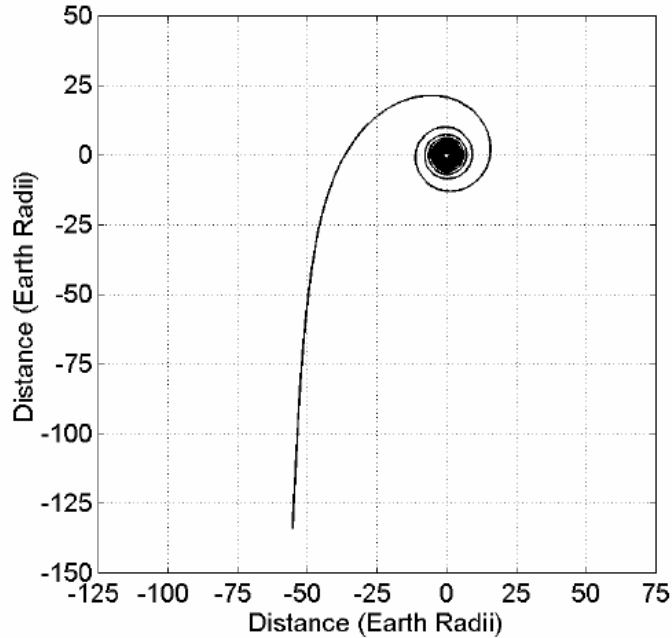

Figure 33. Spiral Out Path of Low Thrust Trajectory

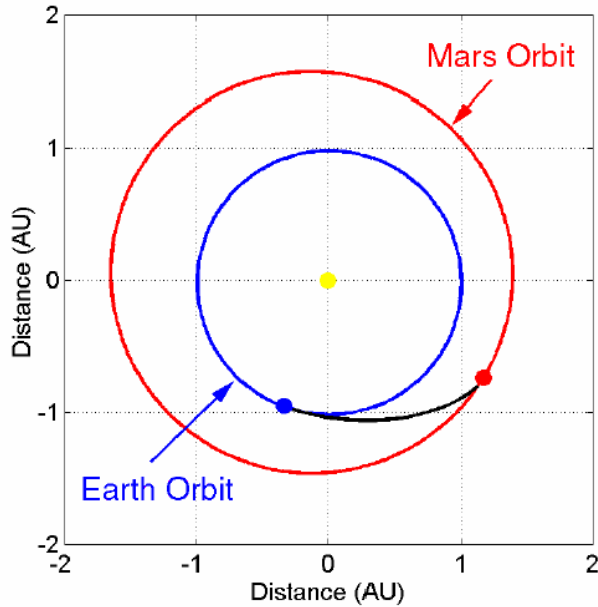

Figure 34. Outbound Leg of Human Piloted Variable Isp Trajectory<sup>97</sup>

<sup>97</sup> Personal Communication with Dr Franklin Chang-Diaz.

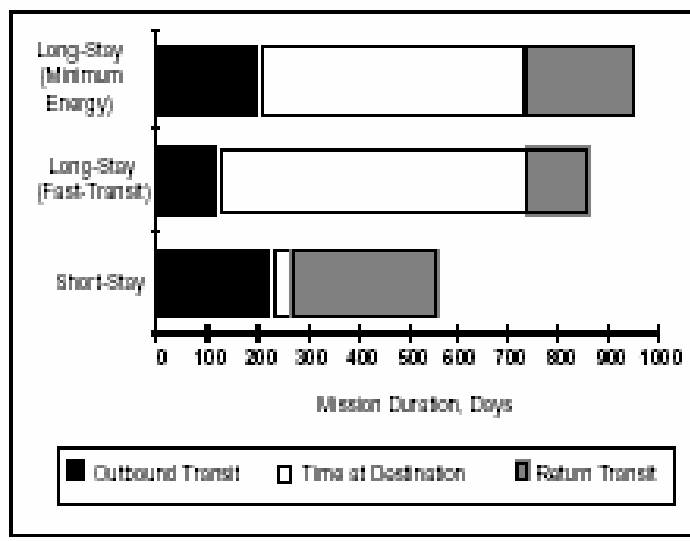

Figure 35. Comparison of Mission Durations and Mission Types

As seen in the above figure, the comparison shows that the duration of the stay on Mars is not directly proportional to the transit duration. The long stay (conjunction), fast-transit mission reduces the unknown risk of GCR and SPE radiation effects as well as physiological zero gravity effects.

### 3. Abort Scenarios

Abort scenarios are more severe for a Mars mission than for other manned expeditions due to the distances involved. The  $\Delta v$  requirements for a return at an unplanned for point requires an excessive amount of fuel, and each point of return cannot be planned for by increasing the amount of fuel carried onboard. The reliability of each part of the spacecraft must be high as well as the capability to be fixed real time. Redundancy features must be implemented to the highest extent. Abort safe haven options include but are not limited to either the Moon/earth L1 and L2 points, Mars orbit, Mars surface. With traditional chemical stages and NTR you severely limit the options you have because of not being able to control the thrust of the vehicle during the entire duration of interplanetary space travel.

### 4. Timing

The timing of the manned Mars mission is the one of the more important planning factors in the mission. Earth and Mars orbit the sun in such a manner that the launch opportunities repeat themselves each 26 months, according to which trajectory is going to

be flown. In addition to which type of trajectory used for a manned Mars mission, the timing needs to be considered as well. The timing of the mission should include the same aspects as have all great explorations: weather, distance, trajectory options, technology maturation, and funding.

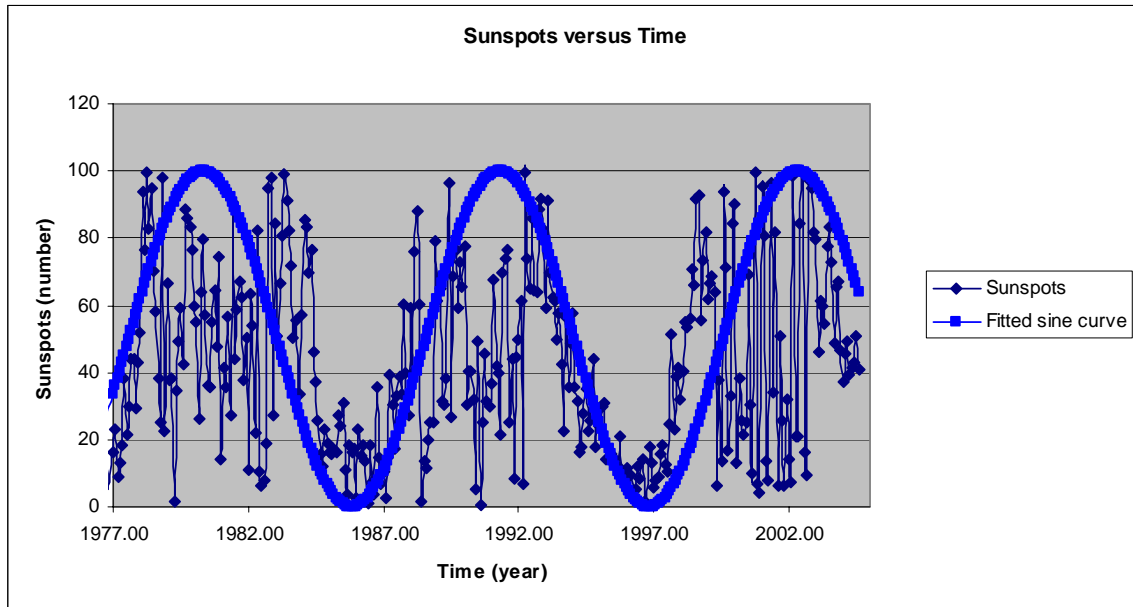

Figure 36. Number of Sunspots versus Time with Sine Curve Approximation

Before climbing Mount Everest or beginning a long sea voyage, the weather would be a primary consideration. Inter-solar system weather is attributable from the sun. Data exists for sunspot activity, a major indicator of solar weather, dating back to 1749.<sup>98</sup> Plotting this data over time, as done in the above figure, shows that there is an eleven year cycle in sunspot activity, which also corresponds to solar particle events (SPE). A sine curve approximation has been placed on top of the data to simplify the presentation. Understanding that the radiation from outside the solar system, GCR, is more dangerous than solar flare activity, as discussed in the shielding section of the thesis, allows us to plan a launch near solar maximum to allow for the sun's shielding effects. However, this must be weighted against the potential for communication's difficulties common during solar events.

<sup>98</sup> <http://science.nasa.gov/ssl/pad/solar/sunspots.htm>, 25 Oct 04

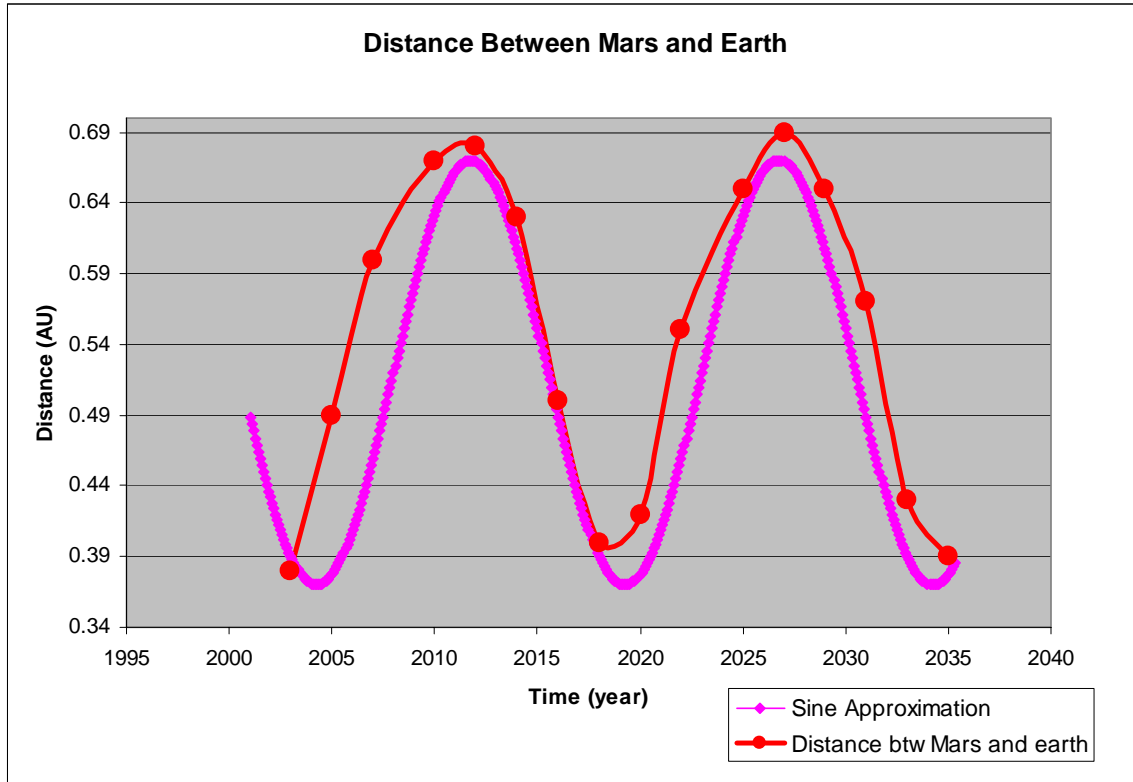

Figure 37. Distance Between Mars and earth with Sine Approximation

The mean distance between Mars and earth should be another consideration when determining mission viability. Because Mars and earth are both rotating around the sun, their combined orbital paths allow for a launch opportunity every 26 months. The distance at each of those opportunities differs between 0.4AU and 0.7AU. The figure above shows these distances between earth and Mars at each launch opportunity. A sine curve approximation has been placed on top of the data for simplification. As shown above, the earth/Mars distance cycle is approximately 15 years.

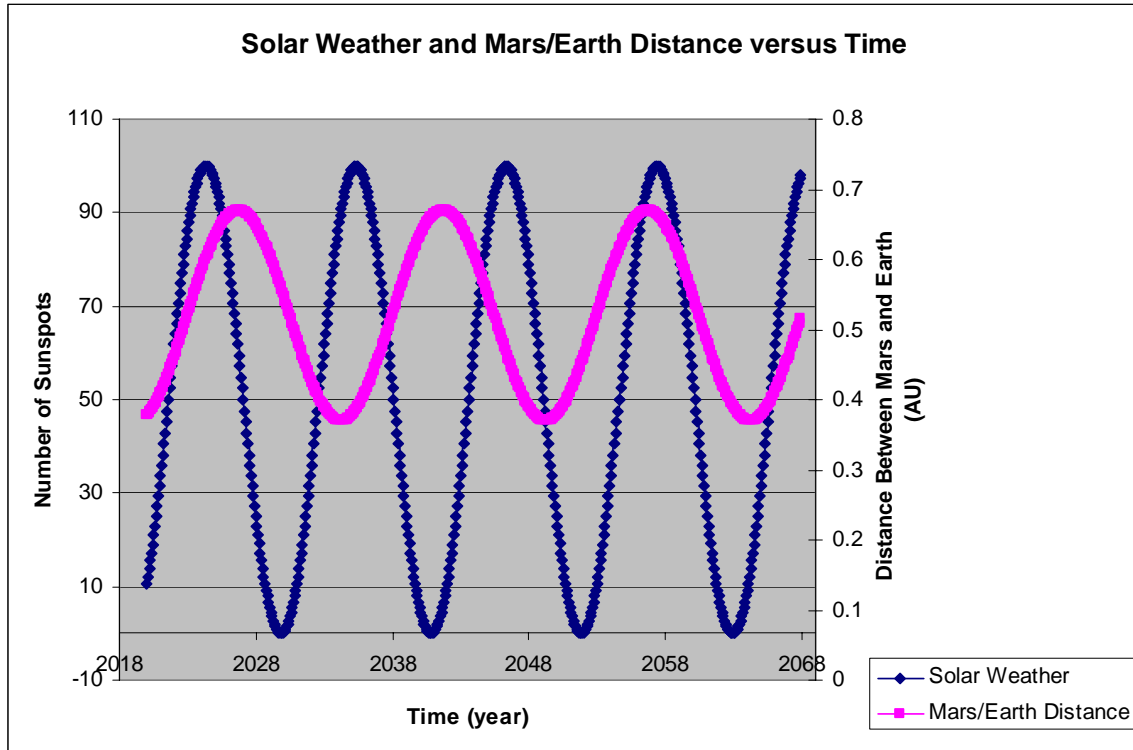

Figure 38. Solar Weather and Distance between Mars and earth versus Time

By combining the weather curve with the distance curve the best times to send a manned mission to Mars is more apparent. The earliest favorable time to send astronauts is 2033-2038. Again in 2043 is another good time to launch. The President's plan of launching a manned mission to Mars has been estimated to occur near 2030. With reasonable planning now, a NEP system can be designed to meet this challenge.

## INITIAL DISTRIBUTION LIST

1. Defense Technical Information Center  
Ft. Belvoir, VA
2. Dudley Knox Library  
Naval Postgraduate School  
Monterey, CA
3. Dr. Anthony Healey  
Chairman, Code MAE  
Department of Mechanical and Astronautical Engineering  
Naval Postgraduate School  
Monterey, CA
4. Dr. Sherif Michael  
Department of Electrical and Computer Engineering  
Naval Postgraduate School  
Monterey, CA
5. Dr. Oscar Biblarz  
Department of Mechanical and Astronautical Engineering  
Naval Postgraduate School  
Monterey, CA
6. CAPT Daniel Bursch  
Associate Dean, GSEAS  
Naval Postgraduate School  
Monterey, CA
7. Dr. Franklin Chang-Diaz  
Advanced Space Propulsion Laboratory  
Houston, TX
8. CDR Steve Bowen  
Astronaut Office, NASA  
Houston, TX
9. Scott McGinnis  
Naval Postgraduate School  
Monterey, CA