



NAVAL POSTGRADUATE SCHOOL

MONTEREY, CALIFORNIA

THESIS

**RADAR SEARCH AND DETECTION WITH THE
CASA 212 S43 AIRCRAFT**

by

Jose Manuel Landa Borges

December 2004

Thesis Advisor:
Second Reader:

Steven E. Pilnick
Matthew G. Boensel

Approved for public release; distribution is unlimited

THIS PAGE INTENTIONALLY LEFT BLANK

REPORT DOCUMENTATION PAGE			Form Approved OMB No. 0704-0188
Public reporting burden for this collection of information is estimated to average 1 hour per response, including the time for reviewing instruction, searching existing data sources, gathering and maintaining the data needed, and completing and reviewing the collection of information. Send comments regarding this burden estimate or any other aspect of this collection of information, including suggestions for reducing this burden, to Washington headquarters Services, Directorate for Information Operations and Reports, 1215 Jefferson Davis Highway, Suite 1204, Arlington, VA 22202-4302, and to the Office of Management and Budget, Paperwork Reduction Project (0704-0188) Washington DC 20503.			
1. AGENCY USE ONLY (Leave blank)	2. REPORT DATE December 2004	3. REPORT TYPE AND DATES COVERED Master's Thesis	
4. TITLE AND SUBTITLE: Radar Search and Detection with the CASA 212 S43 Aircraft		5. FUNDING NUMBERS	
6. AUTHOR(S) Jose Manuel Landa Borges		8. PERFORMING ORGANIZATION REPORT NUMBER	
7. PERFORMING ORGANIZATION NAME(S) AND ADDRESS(ES) Naval Postgraduate School Monterey, CA 93943-5000		10. SPONSORING/MONITORING AGENCY REPORT NUMBER	
9. SPONSORING /MONITORING AGENCY NAME(S) AND ADDRESS(ES) N/A		11. SUPPLEMENTARY NOTES The views expressed in this thesis are those of the author and do not reflect the official policy or position of the Department of Defense or the U.S. Government.	
12a. DISTRIBUTION / AVAILABILITY STATEMENT Approved for public release; distribution is unlimited		12b. DISTRIBUTION CODE	
13. ABSTRACT (maximum 200 words) This research develops a detection rate model to analyze the effectiveness of the RDR 1500B search radar installed in the CASA 212 S43 aircraft belonging to Venezuelan Naval Aviation. The model is based on a search and detection mission to find a diesel submarine executing an incursion inside the Venezuelan Caribbean Sea area, assumed to be intermittently operating with periscopes or masts exposed above the sea surface. The analysis obtains cumulative probability of detection vs. time based on the radar manufacturer's performance data, user inputs for aircraft search area size, search speed, and search altitude, and submarine periscope or mast exposure profile. The model can use given periscope radar cross section data, or roughly calculate radar cross section given assumptions about exposed periscope height above the sea-surface and sea-state conditions. Submarine evasion due to radar counter-detection is also modeled.			
14. SUBJECT TERMS RDR 1500B Search Radar; CASA 212 S43 Aircraft; Search and Detection; Submarine Periscope Exposure		15. NUMBER OF PAGES 101	16. PRICE CODE
17. SECURITY CLASSIFICATION OF REPORT Unclassified	18. SECURITY CLASSIFICATION OF THIS PAGE Unclassified	19. SECURITY CLASSIFICATION OF ABSTRACT Unclassified	20. LIMITATION OF ABSTRACT UL

NSN 7540-01-280-5500

Standard Form 298 (Rev. 2-89)
Prescribed by ANSI Std. Z39-18

THIS PAGE INTENTIONALLY LEFT BLANK

Approved for public release; distribution is unlimited

RADAR SEARCH AND DETECTION WITH THE CASA 212 S43 AIRCRAFT

José Manuel Landa Borges
Lieutenant Commander (Venezuelan Navy)
B.S., Venezuelan Naval School, 1989

Submitted in partial fulfillment of the
requirements for the degree of

MASTER OF SCIENCE IN OPERATIONS RESEARCH

from the

**NAVAL POSTGRADUATE SCHOOL
December 2004**

Author: Jose Manuel Landa Borges

Approved by: Steven E. Pilnick
Thesis Advisor

Matthew G. Boensel
Second Reader

James N. Eagle
Chairman, Department of Operations Research

THIS PAGE INTENTIONALLY LEFT BLANK

ABSTRACT

This research develops a detection rate model to analyze the effectiveness of the RDR 1500B search radar installed in the CASA 212 S43 aircraft belonging to Venezuelan Naval Aviation. The model is based on a search and detection mission to find a diesel submarine executing an incursion inside the Venezuelan Caribbean Sea area, assumed to be intermittently operating with periscopes or masts exposed above the sea surface. The analysis obtains cumulative probability of detection vs. time based on the radar manufacturer's performance data, user inputs for aircraft search area size, search speed, and search altitude, and submarine periscope or mast exposure profile. The model can use given periscope radar cross section data, or roughly calculate radar cross section given assumptions about exposed periscope height above the sea-surface and sea-state conditions. Submarine evasion due to radar counter-detection is also modeled.

THIS PAGE INTENTIONALLY LEFT BLANK

TABLE OF CONTENTS

I.	INTRODUCTION.....	1
A.	PURPOSE.....	1
B.	SCOPE.....	1
C.	METHODOLOGY.....	2
1.	Data Sources.....	2
2.	Radar and Aircraft Parameter Identification.....	2
3.	Radar Cross Section Development.....	2
4.	RDR 1500B Radar Footprint Determination.....	2
5.	Lateral Range and Sweep Width Development.....	2
6.	Search Model Development.....	2
7.	Analysis of Results.....	2
D.	ORGANIZATION OF THE STUDY.....	3
II.	SCENARIO DESCRIPTION.....	5
III.	CASA 212 S43 AIRCRAFT OVERVIEW.....	7
A.	GENERAL INFORMATION.....	7
B.	TECHNICAL FEATURES.....	8
1.	Radar Frequency and Wavelength.....	8
2.	Pulse Repetition Frequency.....	9
3.	Maximum Unambiguous Detection Range.....	9
4.	Minimum Detection Range.....	9
5.	Maximum Detection Range.....	10
6.	Antenna Effective Aperture.....	12
7.	Horizontal Coverage.....	12
C.	RADAR CROSS SECTION.....	13
1.	Definitions.....	13
2.	Cylinder Target.....	16
D.	MISCELLANEOUS FEATURES OF THE RDR 1500B RADAR SEARCH.....	19
E.	OPERATIONAL CHARACTERISTICS OF THE CASA 212 S43 AIRCRAFT.....	21
1.	Searching Operational Speed.....	21
2.	Flight Altitude.....	22
3.	Search Area.....	22
4.	Radar Horizon.....	22
IV.	DETECTION RATE MODEL APPLIED TO RDR 1500B SEARCH RADAR.....	25
A.	DETECTION RATE MODEL OVERVIEW.....	25
B.	DETECTION RATE MODEL THEORY.....	27
C.	DEVELOPMENT OF THE DETECTION RATE.....	28
1.	Periscope Exposure Rate.....	29

	a.	<i>Operational Period</i>	29
	b.	<i>Periscope Exposure Hours</i>	30
	c.	<i>Radar Glimpse Interval</i>	30
	d.	<i>Glimpse Count</i>	30
2.		Sweep Width and Lateral Range Function	31
	a.	<i>Option One</i>	31
	b.	<i>Option Two</i>	32
3.		Approximation of the Lateral Range Function	32
4.		Effective Sweep Width	38
5.		Effective Sweep Rate.....	40
6.		Radar Patch Coverage	40
7.		Radar Detection Patch Coverage Probability.....	41
8.		Counter-Detection by the Submarine	41
9.		Detection Rate.....	41
V.		ANALYSIS OF THE RESULTS	43
A.		OPERATIONAL SEARCH AREA	43
	1.	Total Search Area of 125,000 nm ² and One Aircraft	44
	2.	Total Search Area of 125,000 nm ² and Two Aircraft	44
	3.	Total Search Area of 62,500 nm ² and One Aircraft	45
	4.	Total Search Area of 62,500 nm ² and Two Aircraft	46
	5.	Total Search Area of 31,200 nm ² and One Aircraft	47
	6.	Total Search Area of 31,200 nm ² and Two Aircraft	48
	7.	Total Search Area of 15,600 nm ² and One Aircraft	48
	8.	Total Search Area of 7,800 nm ² and One Aircraft	49
	9.	Total Search Area of 3,900 nm ² and One Aircraft	50
B.		PERIOD OF TIME TARGET PERISCOPES OR MASTS EXPOSED ABOVE THE SEA SURFACE	50
	1.	Three-Hour Exposure	51
	2.	Six-Hour Exposure	51
	3.	Nine-Hour Exposure	52
	4.	Twelve-Hour Exposure	52
C.		SEA STATE CORRECTION FACTOR APPLICATION	53
	1.	Three-Hour Exposure at Sea State Smooth.....	53
	2.	Three-Hour Exposure at Sea State Moderate.....	54
	3.	Three-Hour Exposure at Sea State Rough.....	55
	4.	Twelve-Hour Exposure at Sea State Smooth	56
	5.	Twelve-Hour Exposure at Sea State Moderate.....	57
	6.	Twelve-Hour Exposure at Sea State Rough	57
	7.	Twelve-Hour Exposure at Sea State Very Rough.....	58
D.		COUNTER DETECTION CAPABILITY	59
	1.	Three-Hours Exposure at Sea State Smooth.....	59
	2.	Three-Hour Exposure at Sea State Moderate.....	60
	3.	Three-Hour Exposure at Sea State Rough.....	61
	4.	Twelve-Hour Exposure at Sea State Smooth	62
	5.	Twelve-Hour Exposure at Sea State Rough	62

VI.	CONCLUSIONS AND RECOMMENDATIONS.....	65
A.	GENERAL.....	65
B.	CONCLUSIONS.....	65
C.	RECOMMENDATIONS.....	68
	APPENDIX.....	69
	LIST OF REFERENCES.....	73
	INITIAL DISTRIBUTION LIST.....	75

THIS PAGE INTENTIONALLY LEFT BLANK

LIST OF FIGURES

Figure 1.	Venezuelan Caribbean Sea (Submarine’s Operating Area).....	5
Figure 2.	CASA 212 Series 200 Aircraft.....	7
Figure 3.	CASA 212 S43 Aircraft.....	7
Figure 4.	Tactical Operator Station.....	8
Figure 5.	Minimum Range Calculation.....	9
Figure 6.	Pattern Produced by Antenna.....	10
Figure 7.	Horizontal Coverage and Silence Radar Zone.....	12
Figure 8.	Concept of Radar Cross Section [11].....	14
Figure 9.	Compared Reflection of the Target.....	14
Figure 10.	Graphical Representation of the RCS of Small Target.....	18
Figure 11.	Graphical Representation of the RCS of Medium Target.....	18
Figure 12.	Graphical Representation of the RCS of Large Target.....	19
Figure 13.	RCS vs. Ranges at 200 Feet.....	20
Figure 14.	Lateral Range (CPA).....	33
Figure 15.	Relative Motion of Target.....	34
Figure 16.	Lateral Range Small Target.....	35
Figure 17.	Lateral Range Medium Target.....	36
Figure 18.	Lateral Range Large Target.....	36
Figure 19.	Sweep Width for a Small Target.....	39
Figure 20.	Sweep Width for a Medium Target.....	39
Figure 21.	Sweep Width for a Large Target.....	40
Figure 22.	CDP vs. Time Using 125,000 nm ² and One Aircraft.....	44
Figure 23.	CDP vs. Time Using 125,000 nm ² and Two Aircraft.....	45
Figure 24.	CDP vs. Time Applying 62,500 nm ² and One Aircraft.....	46
Figure 25.	CDP vs. Time Applying 62,500 nm ² and Two Aircraft.....	47
Figure 26.	CDP vs. Time Applying 31,200 nm ² and One Aircraft.....	47
Figure 27.	CDP vs. Time Applying 31,200 nm ² and Two Aircraft.....	48
Figure 28.	CDP vs. Time Applying 15,600 nm ² and One Aircraft.....	49
Figure 29.	CDP vs. Time Applying 7,800 nm ² and One Aircraft.....	49
Figure 30.	CDP vs. Time Applying 3,900 nm ² and One Aircraft.....	50
Figure 31.	CDP vs. Time Applying 3,900 nm ² and Six-Hour Exposure.....	51
Figure 32.	CDP vs. Time Applying 3,900 nm ² and Nine-Hour Exposure.....	52
Figure 33.	CDP vs. Time Applying 3,900 nm ² and Twelve-Hour Exposure.....	53
Figure 34.	Three-Hour Exposure at Sea State Smooth.....	54
Figure 35.	Three-Hour Exposure at Sea State Moderate.....	54
Figure 36.	Three-Hour Exposure at Sea State Rough.....	55
Figure 37.	Twelve-Hour Exposure at Sea State Smooth.....	56
Figure 38.	Twelve-Hour Exposure at Sea State Moderate.....	57
Figure 39.	Twelve Hours Periscope Exposed at Sea State Rough.....	58
Figure 40.	Twelve-Hour Exposure at Sea State Very Rough.....	58

Figure 41.	Counter-Detection Capability and Three-Hour Exposure at Sea State Smooth.....	59
Figure 42.	Counter-Detection Capability and Three-Hour Exposure at Sea State Moderate.....	60
Figure 43.	Counter-Detection Capability and Three-Hour Exposure at Sea State Rough	61
Figure 44.	Counter-Detection Capability and Twelve-Hour Exposure at Sea State Smooth.....	62
Figure 45.	Counter-Detection Capability and Twelve-Hour Exposure at Sea State Rough	63
Figure 46.	RCS vs. Ranges at 500 Feet.....	69
Figure 47.	RCS vs. Ranges at 1000 Feet.....	70
Figure 48.	RCS vs. Ranges at 1500 Feet.....	71
Figure 49.	RCS vs. Ranges at 2000 Feet.....	72

LIST OF TABLES

Table 1.	Tilt Angles.....	10
Table 2.	World Meteorological Organization Sea State Code [16]	15
Table 3.	Sea State Correction Factor	16
Table 4.	Radar Cross Section Data.....	17
Table 5.	Tilt and Elevation Angles, Minimum Range and Radar Horizon	21
Table 6.	CASA 212 S43 Aircraft Operational Characteristics	21
Table 7.	Lateral Range Curve Data.....	37
Table 8.	Developed Lateral Range Curve Data for a Small Target	37
Table 9.	Developed Lateral Range Curve Data for a Medium Target.....	37
Table 10.	Developed Lateral Range Curve Data for a Large Target	38

THIS PAGE INTENTIONALLY LEFT BLANK

ACKNOWLEDGMENTS

This work would not have been possible without the enormous support of my thesis advisor, Professor Steven E. Pilnick, to who I extend my great appreciation. His expert advice, directions and patience have allowed me to finish this challenge.

Besides, I wish to thank my wife, Imelda Marina, my children, Freddy and Jose, and my mother, Gladys, for being patient during the time when I was absent.

Additionally, I wish to thank my father and my friend Francisco who are not present but sometimes they pushed me to continue working hard to obtain this big challenge.

Finally, I want to thank my friends Rogelio, Orlando, Nancy and anyone else who were unconditionally helping me in translating and supporting my interpretations.

THIS PAGE INTENTIONALLY LEFT BLANK

EXECUTIVE SUMMARY

1. Introduction

The Venezuelan Naval Aviation Command uses the CASA 212 S43 aircraft for maritime patrol in the Venezuelan Caribbean Sea area. During a recent scheduled upgrade, the RDR 1500B search radar system was installed. This research develops a detection rate model to analyze the effectiveness of the RDR 1500B search radar installed in the CASA 212 S43 aircraft belonging to Venezuelan Naval Aviation. The model is based on a search and detection mission to find a diesel submarine executing an incursion inside the Venezuelan Caribbean Sea area, assumed to be intermittently operating with periscopes or masts exposed above the sea surface.

This model, developed in Microsoft Excel, will assist in evaluating the effectiveness of radar tactics by the CASA 212 S43 aircraft. It will also serve as a training model for the aircrews, who could determine the probability of detection resulting from varying search area sizes, operation time, and target characteristics. Additionally, the model may also prove useful as a tactical decision aid.

2. RDR 1500B Search Radar Performance

The maximum detection range (R_{max}) is the most important characteristic of the radar used in this investigation. Manufacturer provided performance graphs of the RDR 1500B when operated at various altitudes, give maximum detection ranges as a function of target radar cross section (RCS).

Actual submarine periscope RCS data could be used if it were available. However, lacking actual data, RCS is computed using the physics of radar reflection, assumptions about exposed periscope height and shape, and assumptions about sea surface radar reflection in various sea states. The model is set up to simultaneously calculate results for three different periscope target

sizes called small, medium and large. The periscopes are treated as approximately cylindrical in shape, and the differences in size are the height of the submarine periscope above the sea surface. It is assumed that in sea-state zero, perfect corner reflection between the vertical periscope and the flat sea-surface produces the same RCS as if the angle of incidence of the radar were perpendicular to the side of the cylinder. It is further assumed that increasing sea-states reduce the percentage of time that perfect corner reflection is achieved, and thus results in proportionally smaller RCS.

Maximum radar detection range, depending on aircraft altitude and target RCS is used to compute other parameters of interest in the detection rate model.

3. Detection Rate Model Overview

The detection rate model is developed in order to analyze the probability of radar detection of a submarine that is only detectable during occasional periods of periscope exposure.

The idea underlying the detection rate is that the rate at which detections can be made is governed by the rate at which occasional periscope exposures occur. Then, when an exposure occurs, it can result in detection if the searching aircraft radar happens to be covering the patch of ocean where the submarine periscope happens to be and the submarine does not evade due to counter-detection. This idea is summarized as follows:

$$\left[\begin{array}{c} \text{Detection} \\ \text{Rate} \end{array} \right] = \left[\begin{array}{c} \text{Rate of submarine} \\ \text{periscope exposure} \\ \text{opportunities} \end{array} \right] * P \left[\begin{array}{c} \text{Aircraft radar} \\ \text{detection patch} \\ \text{is covering spot} \\ \text{when periscope} \\ \text{exposure occurs} \end{array} \right] * P \left[\begin{array}{c} \text{Submarine does} \\ \text{not avoid detection} \\ \text{due to radar} \\ \text{counter-detection} \end{array} \right]$$

The periscope exposure rate or detection opportunity rate is computed based on user inputs concerning the submarine operating profile, such as hours

per day at periscope depth for recharging batteries, communicating, or looking at surface ships. The current version of this model computes a constant opportunity rate, but the model could be easily adapted to allow for an opportunity rate that varies by time of day, for example.

In developing the overall model, it was convenient to consider that the searching aircraft lays down a pattern of discrete non-overlapping radar patches. The time it takes the aircraft to fly over one patch, which depends on the specified aircraft search speed and the length of the patch, provides a convenient time step for computations within the model, and a natural time unit with which to derive the periscope exposure rate or detection opportunity rate.

In this thesis, the probability that the searching aircraft radar happens to be covering the patch of ocean where the submarine periscope happens to be is called the *radar detection patch coverage probability*. The radar detection patch coverage probability is simply the ratio of the area of the effective radar patch to the search area within which a submarine is assumed to be operating. It is assumed that the uncertain submarine position, when exposed, is equally to be likely anywhere in the search area.

The area of the effective radar patch is the product of the length of the patch times the effective sweep width of the radar. Effective sweep width is obtained by taking the integral of the radar lateral range function over all possible closest points of approach between the aircraft and the target. If actual lateral range curves for the RDR 1500B were available from the manufacturer, or from operational testing, they could be used directly. However, lacking such data, a lateral range function was approximated based on the geometry of the RDR 1500B radar footprint and the proportional amount of time that an exposed target will fall within the footprint as a function of the closest point of approach between the exposed target and the aircraft.

The probability that the submarine does not avoid detection because it counter-detected the radar before the radar detected the submarine is obtained by calculating two areas, and taking a ratio. First is the area of the radar detection patch, within which the submarine will be detected if it is caught in that patch of area. The second is the total area inside the airborne radar horizon, within which the submarine can counter-detect the airborne radar. The difference between these two areas represents an area within which the submarine can detect the radar emission, but the airborne radar cannot see the much smaller radar reflection. This affords the submarine a chance to submerge and avoid being caught with exposed periscopes. The ratio of the detection patch area to the radar horizon area thus represents the probability of no submarine evasion due counter-detection.

A more concise summary of the detection rate idea is thus,

$$\left[\begin{array}{c} \text{Detection} \\ \text{rate} \end{array} \right] = \left[\begin{array}{c} \text{Periscope} \\ \text{exposure} \\ \text{rate} \end{array} \right] * P \left[\begin{array}{c} \text{Radar} \\ \text{patch} \\ \text{coverage} \end{array} \right] * P \left[\begin{array}{c} \text{No} \\ \text{counter-detection} \\ \text{evasion} \end{array} \right]$$

Detection rate models are commonly used in search and detection theory for continuous-looking search (see, for example, Wagner, et. al. [1] or Washburn [10]). The general theory of detection rate models applies to the problem addressed in this thesis, namely submarine periscope detection by the RDR 1500B search radar. The current version of the model computes a constant detection rate, but the model could be easily adapted to allow for a detection rate that varies with time. When the detection rate is a constant, γ , then the cumulative detection probability (CDP) as a function of hours of search, t , is

$$\text{CDP}(t) = 1 - e^{-\gamma t} .$$

4. Analysis

Plots of cumulative detection probability versus search time, CDP(t) show graphically how rapidly or slowly CDP grows with time for different operational situations. The plots allow tactical decision makers to answer questions of interest easily for each situation, such as:

- How many hours of search are needed to reach a CDP of .5?
- What CDP can be achieved in a single sortie of 6.15 hours? In 24 cumulative hours of search? In 48 hours? etc.

a. Search Area

For the CASA 212 S43 aircraft a critical period of search is a single sortie time of 6.15 hours, which represents the maximum flight time that the aircraft may be operated in one mission. The model was exercised, starting with the entire Venezuelan Caribbean Sea area and successively halving the search area until cumulative detection probability for a single sortie was seen to be .5 or better. It was found that a search area size of 3900 nm², which could be a box of 60 nm by 65 nm, a reasonable size patrol area for the CASA 212 S43 aircraft, can result in a CDP better than .5 in a single sortie. Figure ES-1 shows the results for a single aircraft search, 3900 nm² search area, 3 hours periscope exposure time per 24 hour operational period, sea-state zero, 200 foot aircraft altitude, 146 knots search speed, and no radar counter-detection by the submarine.

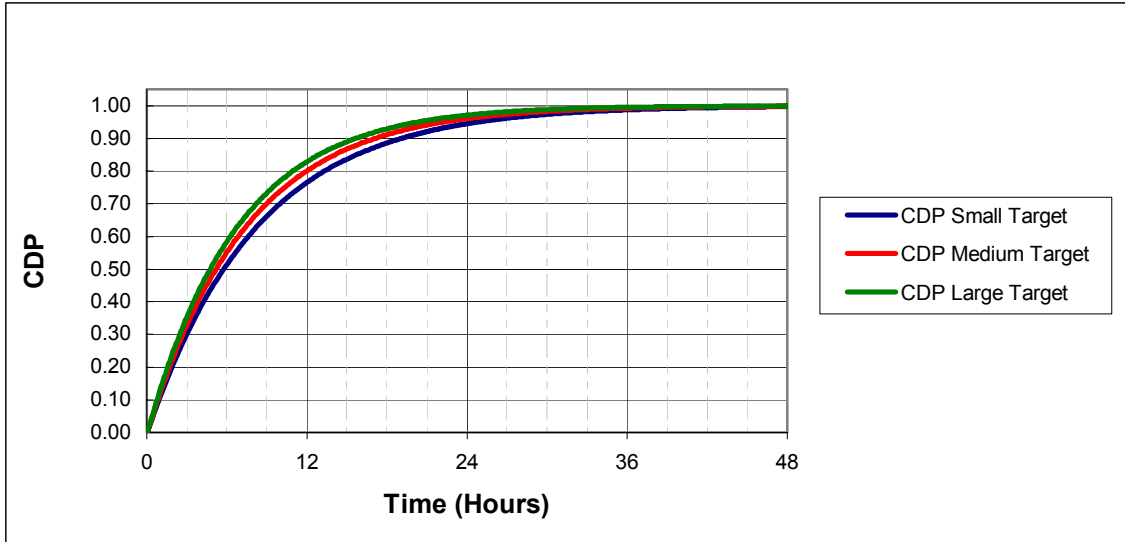

Figure ES-1. CDP vs. Time; Search Area 3,900 nm²

b. Multiple Aircraft

Multiple aircraft or multiple sorties can be employed in two ways to achieve two different results. One method would be to assign sequential sorties to the same search area, which would increase CDP as a function of the total hours of search effort in that area. Alternatively, additional aircraft could be assigned to other search boxes for one sortie each, which would result in the same CDP but over the larger total area searched.

c. Radar Counter-Detection by the Submarine

When the radar horizon from the airborne radar is a longer distance than the maximum detection range, the difference between these two areas represents an area within which the submarine can detect the radar emission, but the airborne radar cannot see the much smaller radar reflection. This affords the submarine a chance to submerge and avoid being caught with exposed periscopes. Fortunately, for the RDR 1500B, low altitude both increases the maximum detection range, and shortens the distance to the radar horizon, and thus minimizes the probability that a submarine can take advantage of a counter-detection capability. However, the CASA 212 S43 aircraft, like most aircraft, does not get best fuel endurance at low altitude. Therefore, there is a tradeoff of flight endurance for detection probability.

d. Sea-State Degradation of RCS

For a fixed periscope exposure height, increasing sea-state has the effect of decreasing target RCS. The effect of RCS reduction creates a compound penalty when the submarine has counter-detection capability. Reduced RCS shortens the maximum effective detection range of radar. This causes two separate factors in the detection rate to diminish. First, the size of the radar patch is reduced, which by itself diminishes the detection rate. Secondly, the shortened radius of the maximum detection area increases the chance that the submarine can avoid detection entirely due to counter-detection evasion, which causes detection rate to diminish further. Both of these factors are approximately proportional to the square of the maximum detection range. Accordingly, the detection rate is approximately proportional to the fourth power of the maximum detection range. If diminished RCS decreases maximum detection range by 10% (i.e., to 90% of the previous maximum detection range) then the detection rate is reduced to roughly $(.9)^4$ or approximately $2/3^{\text{rds}}$ of the previous detection rate. The operational implication of this is that as sea-state increases, the aircraft search plan may need to compensate for the reduced RCS with much smaller search areas and lower search altitudes.

5. Use of the Model

This research developed a search and detection tool in Microsoft Excel to evaluate the effectiveness of radar tactics by the CASA 212 S43 aircraft. This tool can serve as a training model for the aircrews, who could determine the probability of detection resulting from varying search area sizes, operational parameters, and target characteristics. The model may also prove useful as a tactical decision aid.

THIS PAGE INTENTIONALLY LEFT BLANK

I. INTRODUCTION

The Venezuelan Naval Aviation Command is composed of different squadrons, and one is the Maritime Patrol Squadron. The CASA 212 S43 aircraft belongs to this squadron. This aircraft is manufactured by the CASA Company (Construcciones Aeronauticas SA), located in Spain. One of the primary functions established for the use of this aircraft is the support of the afloat units in the search and detection of targets in Venezuelan territorial waters, contiguous zones, economic exclusive zones, and when conducting joint operations [8]. Currently, the procedures executed during maritime patrol, Search and Rescue (SAR), vigilance, and search and detection missions are those implemented for the aircraft when it had the previous search radar system. However, this search radar system was replaced three years ago during scheduled upgrade. The existing procedures were based on standardized patterns written in the flight manual published by the aircraft manufacturer and standardized by pilots of the Venezuelan Naval Aviation Command.

A. PURPOSE

The purpose of this research is to develop a stochastic model to evaluate and to analyze the RDR 1500B search radar installed in the CASA 212 S43 aircraft. The model developed is based on a search and detection mission using the mentioned aircraft. The situation assumed is a diesel submarine executing an incursion inside the Venezuelan Caribbean Sea area. The diesel submarine is assumed to be intermittently operating at periscope depth as explained later in the scenario description.

B. SCOPE

This research focuses on developing a search and detection tool in Microsoft Excel to evaluate the effectiveness of radar tactics by the CASA 212 S43 aircraft. This tool also serves as a training model for the aircrews, who could

determine the probability of detection resulting from varying search area sizes, operation time, and target characteristics. The model may also prove useful as a tactical decision aid.

C. METHODOLOGY

The methodology used in this thesis research consists of the following steps.

1. Data Sources

The data on parameters are obtained directly from open sources, including the radar manufacturer's manuals and the Internet. Prior to operational use, it is necessary to verify the data with the information obtained from official technical manuals.

2. Radar and Aircraft Parameter Identification

This represents a selection and analysis of aircraft and radar parameters to be applied in the search model based on the assumed scenario.

3. Radar Cross Section Development

Develop considerations and create parameters related to diesel submarine periscope exposure.

4. RDR 1500B Radar Footprint Determination

This step develops a representation of the coverage pattern of the radar considered in this study for search and detection of a diesel submarine's periscopes or masts.

5. Lateral Range and Sweep Width Development

Develop considerations and create a lateral range function related to CASA 212 S43 aircraft, the installed radar, and specific target characteristics.

6. Search Model Development

Develop the model to evaluate the effectiveness of the RDR 1500B search radar installed in the CASA 212 S43 based on the assumed scenario.

7. Analysis of Results

This addresses an analysis of results measuring the effectiveness of an area search plan using the RDR 1500B search radar. The search plan includes

the CASA 212 S43 aircraft operated at an established altitude and airspeed searching for a submarine's periscope over an assigned area based on the scenario.

D. ORGANIZATION OF THE STUDY

Chapter II describes the operational scenario used in this study. Chapter III describes the CASA 212 S43 aircraft, overviews features, and investigates some tactical and technical details of the aircraft. This overview provides a more thorough background about the operational particulars of the platform permitting the selection of parameters (flight and radar) related directly to the stochastic search and detection model. This chapter also provides the technical details concerning the determination of target radar cross sections based on different periscope exposure heights above the sea surface.

Chapter IV describes the development of a detection rate model for this problem. It includes development of a submarine periscope exposure rate, the radar detection lateral range function and effective sensor sweep width. It also represents the possibility of radar counter-detection by the submarine.

Chapter V presents the analysis of the data obtained in the spreadsheet model developed in Chapter IV to evaluate and compare the effectiveness of the RDR 1500B search radar for submarine periscope detection under various circumstances.

Chapter VI summarizes all previous chapters and presents conclusions and recommendations to the Venezuelan Naval Aviation Command for future research.

THIS PAGE INTENTIONALLY LEFT BLANK

II. SCENARIO DESCRIPTION

The Maritime Patrol Squadron of the Venezuelan Naval Aviation Command (CAN) uses the CASA 212 S43 aircraft in several pre-established functions in the CAN Doctrine Manual (MAN-DC-CNAOP-0004). One of them is to support surface units in the search and detection of illegal targets navigating in Venezuelan waters [8].

Venezuela has approximately 500,000 square kilometers (193,050 square miles) of territorial waters (territorial sea, contiguous zones, and economic exclusive zones), which are geographically distributed between the Caribbean Sea and the Atlantic Ocean. The area studied in this investigation is the Venezuelan Caribbean Sea shown in Figure 1. It covers approximately 323,760 square kilometers (approximately 125,000 square miles) [9].



Figure 1. Venezuelan Caribbean Sea (Submarine's Operating Area).

Based on the International Maritime Right, each country is responsible for its territorial waters. In this case, the assumption is that Venezuela is facing a situation where a foreign diesel submarine is executing an incursion ordered by the submarine's own country.

The CASA 212 S43 aircraft with the RDR-1500B search radar installed is deployed on a joint naval operation with the mission to search and detect the submarine's periscope. The foreign diesel submarine is intermittently operating at periscope depth anywhere inside the limits of the Venezuelan Caribbean Sea.

Relevant operational details for both the search aircraft and the foreign submarine are treated as parameters that can be varied for analysis. Search aircraft parameters include speed, altitude, and assigned search area. Target submarine parameters include the timing and frequency with which the submarine exposes its periscope or masts, and the radar cross section of the exposed periscope or masts.

III. CASA 212 S43 AIRCRAFT OVERVIEW

A. GENERAL INFORMATION

The CASA 212 S43 is an aircraft manufactured by the CASA Company located in Seville, Spain. The CASA 212 S43 is a specialized version of the CASA 212 Series 200 aircraft (transportation version). The Venezuelan Naval Aviation Command also uses this aircraft to transport tactical troops and cargo to various regions where access is difficult. Figure 2 illustrates this aircraft.



Figure 2. CASA 212 Series 200 Aircraft.

The CASA 212 S43 aircraft, shown in Figure 3, is a modified version of the aircraft illustrated above, which integrates an airborne search and surveillance radar system for sea search operations as its primary mission [2]. Maritime patrol, SAR missions, and anti-submarine duties are the specific uses of the aircraft's mission system. It has a nose dome, which houses the radar antenna and other equipment installed internally and externally on the aircraft enabling it to execute its mission successfully.



Figure 3. CASA 212 S43 Aircraft.

The radar operator station is located on the starboard side of the main cabin [15]. It is a console that incorporates a radar display, long-range system, control display unit (CDU) repeater, antisubmarine warfare (ASW) and intercommunication system (ICS) controls, shown in Figure 4.

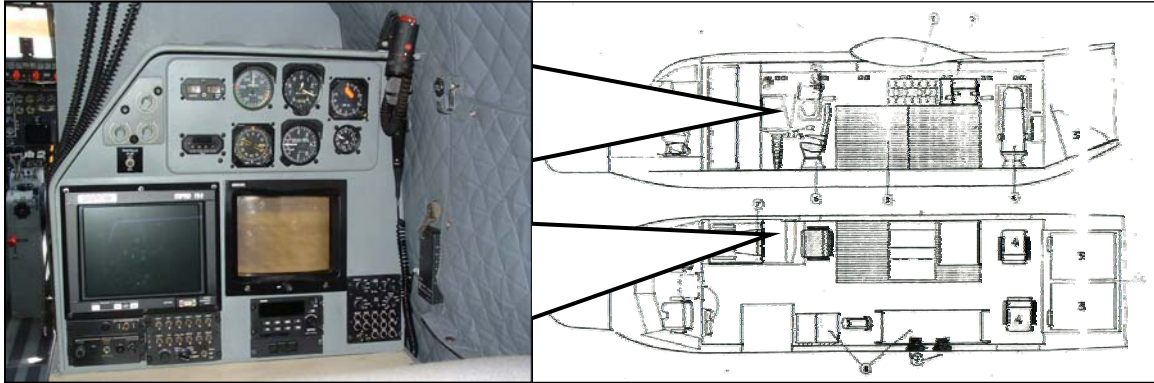

Figure 4. Tactical Operator Station.

B. TECHNICAL FEATURES

This investigation focuses on developing a search and detection tool in Microsoft Excel to evaluate the effectiveness of the RDR 1500B search radar installed on the CASA 212 S43 aircraft. Most of the parameters detailed here refer to the radar features and provide a link to the problem of searching for the periscope of a diesel submarine navigating at periscope depth. The following paragraphs present the technical parameters of interest for the mission analysis. This investigation takes available data and uses radar theory to develop the information necessary for further analysis.

1. Radar Frequency and Wavelength

The RDR 1500B search radar operates in the X-band (9.375 GHz, which represents the number of electromagnetic cycles by second) [2]. Using the relationship shown in Equation 3.1, the wavelength (λ) of the radar can be obtained based on the speed of light (c) of $299,972 \times 10^3$ meters/sec, and the operation frequency (f) shown before. In this case, the result from applying the equation is 3.198 cm.

$$c = \lambda * f \quad (3.1)$$

2. Pulse Repetition Frequency

The pulse repetition frequency of the RDR 1500B search radar is 1600 Hz. This is the frequency used to search for small targets such as a submarine's periscope or a short pulse width (0.1 μ sec) [4].

3. Maximum Unambiguous Detection Range

The basic definition of radar defines the maximum unambiguous detection range (R_u) by measuring the time required for a pulse to return from a target just before the emission of a second pulse [14]. The calculation for RDR 1500B search radar is based on Equation 3.2 [14] and gives a result equal to 50.60 nm.

$$R_u = \frac{c}{2 * f_p} \quad (3.2)$$

4. Minimum Detection Range

The minimum detection range (R_{min}) is 0.351 nm at a search altitude of 200 ft (0.033 nm). This value was calculated using basic trigonometry (see Figure 5). It is possible to compare this value to the graph performance of the RDR 1500B search radar (Figure 13 and Appendix) and the conclusion was that they are almost identical. Basic trigonometry required the search angle. It was determined by using the antenna tilt angle and elevation beam width angle [2] See Figure 5. The small radius around the aircraft represents the minimum detection range (R_{min}), which depicted on the pattern of the radar antenna (see Figure 6).

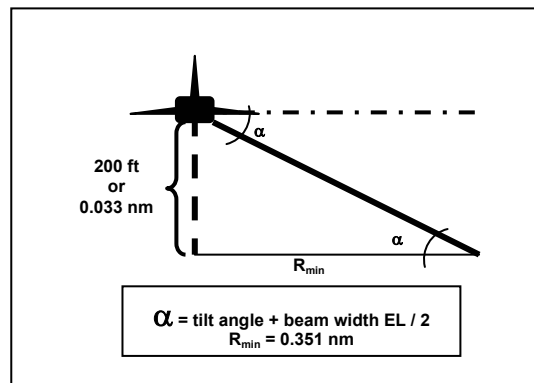

Figure 5. Minimum Range Calculation

Altitudes (ft)	Tilt Angle (degrees)
200	-0.11
500	-0.17
1000	-0.24
1500	-0.29
2000	-0.34

Table 1. Tilt Angles

Table 1 shows the tilt angles for different altitudes, which were obtained from the performance graphs of the RDR 1500B search radar (Figures 13 and Appendix) [3]. The negative sign means the angles represent depression below the horizon. These are used later to calculate minimum range (R_{min}) and radar horizon (R_h) values shown in Table 2.

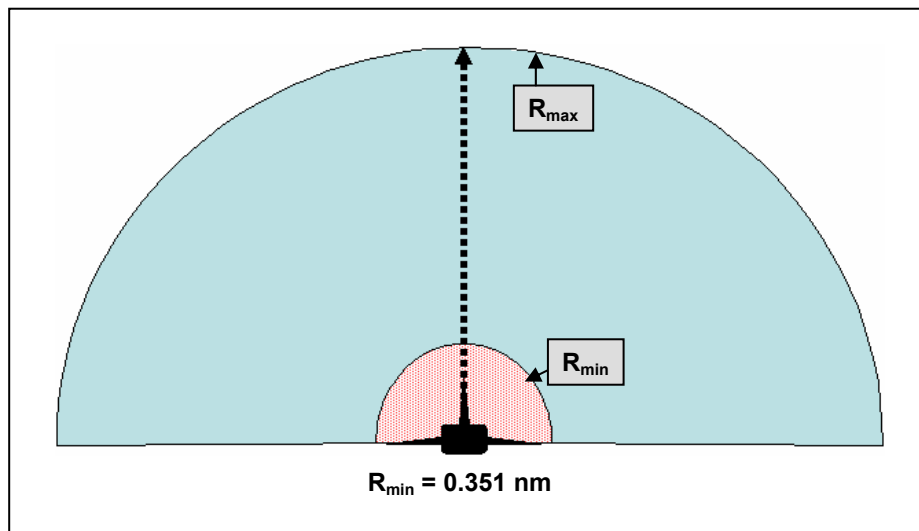

Figure 6. Pattern Produced by Antenna

5. Maximum Detection Range

The maximum detection range (R_{max}) is one of the most important characteristics of this investigation and it is a direct consequence of the radar's parameters. Equation 3.3 presents the relationship or all required to calculate this range. Many of the parameters available in the performance graphs are shown at Figures 13 and Appendix. They are used to calculate the maximum

detection range of the RDR 1500B search radar. The radar cross section of the target (RCS) was determined separately and those calculations are detailed in Chapter IV at RCS section.

$$R_{\max} = \sqrt[4]{\frac{P_t G A_e \sigma}{(4\pi)^2 S_{\min}}} \quad (3.3)$$

From this equation, each parameter represents:

P_t = Transmitted Power

G = Antenna Gain

A_e = Antenna Effective Aperture

σ = Radar Cross Section of the target

S_{\min} = Minimum Detectable Signal

and if the S_{\min} is that value of S_{in} (input signal), which satisfies the relationship $[kT_0BF_n(S_{out}/N_{out})_{\min}]$ and corresponds to the minimum detectable signal-to-noise ratio at the output of the $(S_{out} / N_{out})_{\min}$, then [5].

$$S_{\min} = k T_0 B F_n \left(\frac{S_{out}}{N_{out}} \right)_{\min} \quad (3.4)$$

Each parameter represents:

k = Boltzmann's Constant = 1.38×10^{-23} J / deg

T_0 = Standard Temperature (290° K = 62° F)

B = Receiver Bandwidth

F_n = Noise Figure

$(S_{out} / N_{out})_{\min}$ = Minimum Detectable Signal-To-Noise Ratio $(S/N)_{\min}$

as explained before, the parameters are available in the performance graphs of the RDR 1500B search radar shown in Figures 13 and Appendix.

6. Antenna Effective Aperture

The antenna effective aperture (A_e) is obtained by Equation 3.5. It has a value of 0.102 m^2 . The efficiency is assumed to be 80% efficiency but might be varied in the model developed. This parameter is required to calculate the maximum detection range (R_{\max}) and obtained basing on the antenna gain (G) and the wavelength of radiated energy (λ). Besides these parameters, the factor of efficiency depends on how the radar's antenna is generally working, represented by the Greek letter (η) [6].

$$A_e = \frac{G\lambda^2}{4\pi\eta} \quad (3.5)$$

7. Horizontal Coverage

The horizontal coverage is important to model development. It had to be assumed based on basic radar calculation and approaching the pattern generated by the RDR 1500B search radar. Figure 7 shows this pattern, which was developed in the model.

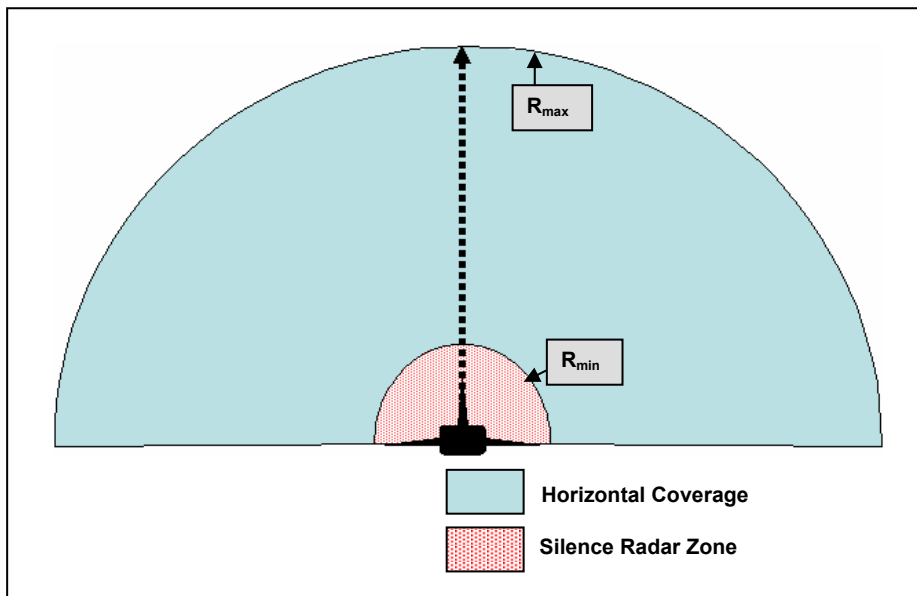

Figure 7. Horizontal Coverage and Silence Radar Zone

C. RADAR CROSS SECTION

This is one of the most important parameters for this research because the target being searched for is very small and difficult to detect from an aerial platform. Actual submarine periscope radar cross-section data could be used if it were available. However, lacking actual data, radar cross-section is computed using the physics of radar reflection, assumptions about exposed periscope height and shape, and assumptions about sea surface radar reflection in various sea states.

In order to see the effect on cumulative detection probability due to submarine periscope radar cross section, the model is set up to simultaneously calculate results for three different periscope target sizes called small, medium and large. The periscopes are treated as approximately cylindrical in shape, and the differences in size are the height of the submarine periscope above the sea surface.

1. Definitions

The radar cross section is the measure of a target's exposed surface area ability to reflect radar signals in the direction of the radar receiver [11]. Also, it determines the power density returned to the radar for a particular power density incident on the target [5]. It is considered the cross-sectional area of a fictitious smooth sphere that scatters incident radar energy in all directions, and produces an echo power back along the incident energy axis equal to the reflection produced by a real target.

It can be viewed as a comparison of the strength of the reflected signal from a target to the reflected signal from a perfectly smooth sphere of cross sectional area of 1 m^2 as shown in Figure 8.

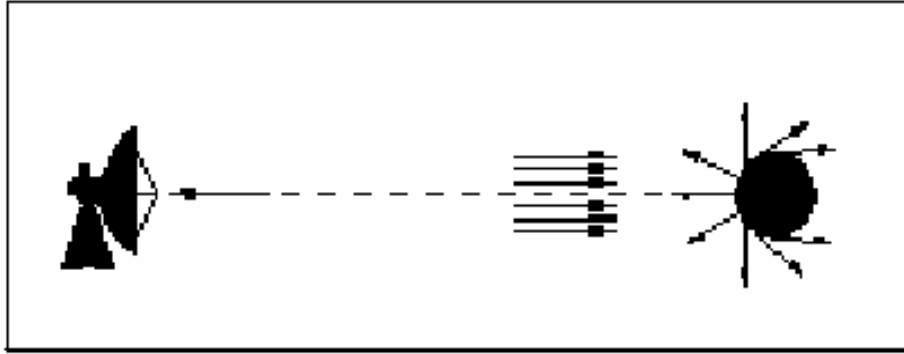

Figure 8. Concept of Radar Cross Section [11]

One of the taken assumptions was the kind of targets selected. The periscopes are assumed to have an approximately cylindrical form. Variations were done with length or height of the periscope above the sea surface (increasing 10 cm from one periscope to another).

Another assumption, initially, was that energy is reflected off of a flat sea surface. Thus, the reflection is similar to the platform looking at the target at a 90° angle (see Figure 9). This situation occurs because the sea surface is like a mirror when very calm. After the initial analysis, corrections are applied to account for sea states that diminish the percentage of time that corner reflection occurs.

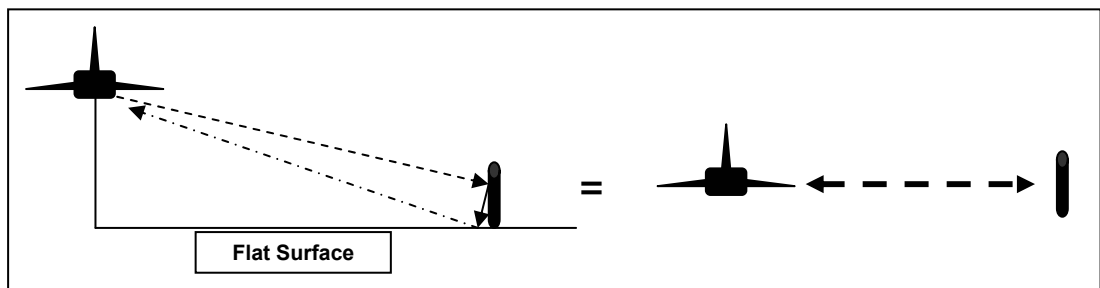

Figure 9. Compared Reflection of the Target

Sea state conditions are described using the world meteorological organization sea state code; this code is a distribution of sea state depending on the characteristics that it presents at any time. The sea state code and its respective characteristics are shown in Table 2.

The analysis in Chapter V is initially done for situations where the sea state is like a mirror or very calm. In other words, the situations are assumed with sea surface corner reflection 100% of the time. Subsequent analysis is conducted to see the effect of sea state degradation of radar cross section and the resulting degradation of cumulative detection probability.

Correction factor are assumed to reduce the RCS of the target based on the sea state code description shown in Table 2. These correction factors are shown in Table 3.

Sea State Code	Description	Average Wave Height (Feet)
0	Sea is like a mirror, it is very calm, the wind speed is less than 1 knot	None
1	Sea is Smooth; wave height 0.1 m; ripples with appearance of scales; no foam; Wind speed 1-3 knots	0.0 - 0.3
2	Small wavelets, crests of glassy appearance, not breaking; wind speeds 4-6 knots	0.3 - 1.7
3	Sea is Moderate; large wavelets; crests begin to break; scattered white caps; wind speeds 7-17 knots.	1.7 - 4.0
4	Sea is rough; moderate waves; many crests break; whitecaps; wind speeds 17-21 knots	4.0 - 8.0
5	Sea is very rough; waves heap up; forming foam streaks; wind speeds 22-27 knots.	8.0 - 13.0
6	Sea is high; sea begins to roll; forming very definite foam streaks and considerable spray; wind speeds 28-40 knots.	13.0 - 20.0
7	Sea is very high; very big; steep waves with wind-driven overhanging crests; sea surface whitens due to dense coverage with foam; wind speeds 41-47 knots.	20.0 - 30.0
8	Sea is mountainous; very high-rolling breaking waves; sea surface foam-covered; wind speeds 48-55 knots.	30.0 - 45.0
9	Sea is mountainous; air filled with foam, sea surface white with spray; wind speeds 56-63 knots.	45 and greater

Table 2. World Meteorological Organization Sea State Code [16]

The correction factors are based on the following information. For sea state zero (0) the reflection is constant, as if the platform is looking at the target at 90° (Figure 9). For sea state one (1) the reflection is assumed 90% of the time because the sea condition is smooth. For sea state two (2) the reflection is assumed 75% of the time because the sea condition is slight and the waves are smaller than the assumed height of the submarine periscope. For sea state three (3) the reflection is assumed 50% of the time because the sea condition is moderate and the reflection might still be obtained. For sea state four (4) the reflection is only assumed 25% (one fourth) of the time because in this situation it is rough to detect any type of target. For sea state five (5) or higher (six – nine) the situations are more difficult. The assumed correction factors to these sea states are distributed from 5.0% to 0.01% of the time.

SEA STATE		
Sea State	Correction factor	Condition
0	100.00%	Flat Surface
1	90.00%	Smooth
2	75.00%	Slight
3	50.00%	Moderate
4	15.00%	Rough
5	2.50%	Very Rough
6	1.00%	High
7	0.15%	Very High
8	0.07%	Mountainous
9	0.01%	Very Mountainous

Table 3. Sea State Correction Factor

2. Cylinder Target

The RCS of a target with an approximately cylindrical form may be approximated by Equation 3.6. The factors that integrate the equation are the wavenumber, which is $2 \pi / \lambda$, the radius of the target (r) and the square of length (l^2) [12].

$$\text{Cylinder Target RCS} = \frac{2 \pi r l^2}{\lambda} \quad (3.6)$$

This equation is used to generate the approximate radar cross section of the targets. The results applying this equation were calculated in a spreadsheet and are shown at Table 4. These results represent the radar cross sections when the sea state is assumed zero (0).

Radar Cross Section				
	Small Target	Medium Target	Large Target	
$kr = 2\pi r/\lambda =$	29.47	29.47	29.47	
wavenumber (k) =	196.49	196.49	196.49	
radius (r) =	0.15	0.15	0.15	m
c =	2.998E+08	2.998E+08	2.998E+08	m/sec
Radar Frequency =	9.375E+09	9.375E+09	9.375E+09	Hz
wavelength (λ) =	3.198E-02	3.198E-02	3.198E-02	m
Length (L) =	0.50	0.60	0.70	m
RCS =	7.368	10.610	14.442	m ²
RCS (dBm2) =	8.674	10.257	11.596	dBm ²

Table 4. Radar Cross Section Data

Those results for each target size compared with the graphs shown in Figures 10 through 12 reveal very similar results. These graphical representations were obtained by a program run in MATLAB to compute and graph RCS of simple targets [13]. The required data were radar frequency, radius of the target, and the length of the exposed target. The importance of these results is the accuracy of the obtained values after their comparison.

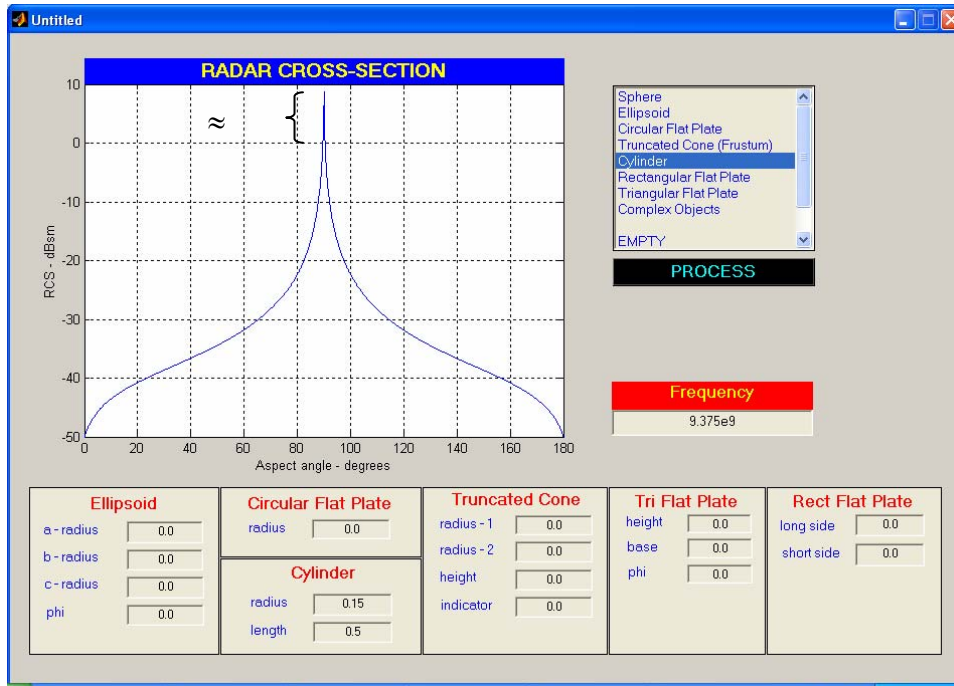

Figure 10. Graphical Representation of the RCS of Small Target

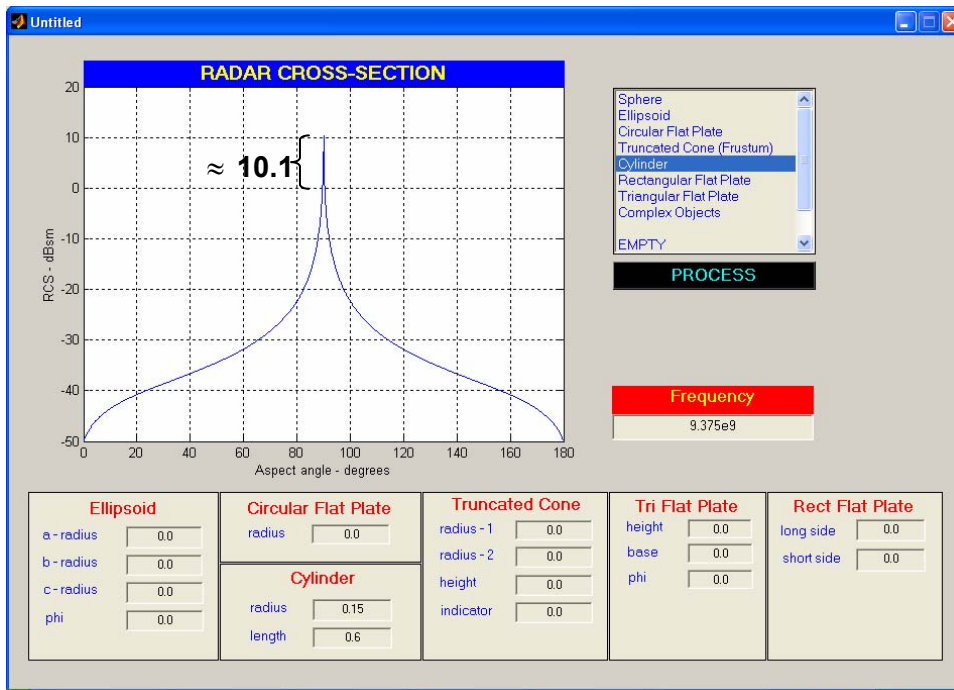

Figure 11. Graphical Representation of the RCS of Medium Target

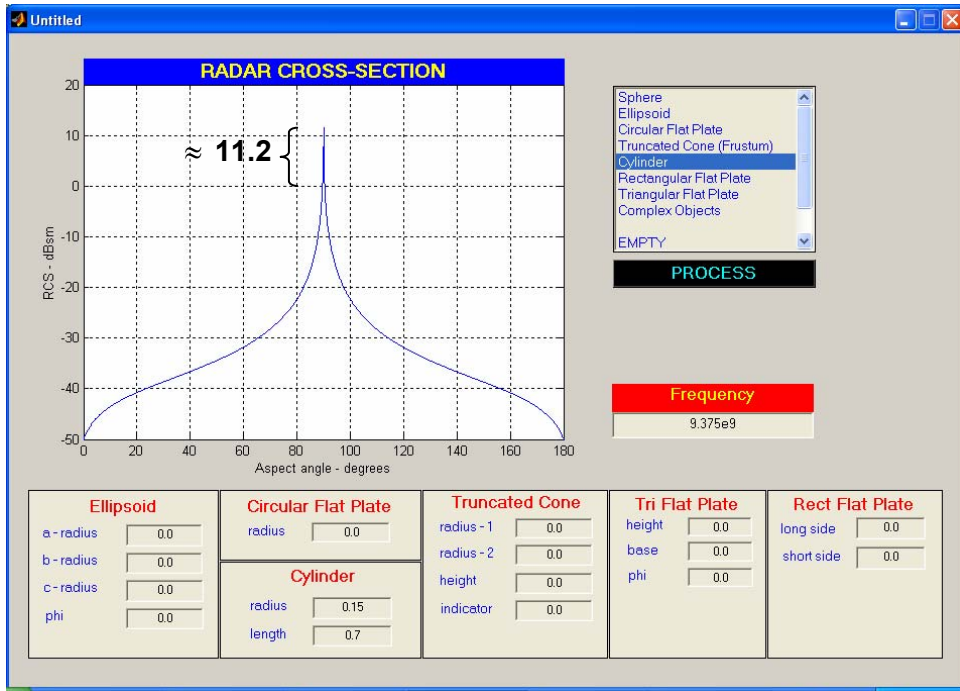

Figure 12. Graphical Representation of the RCS of Large Target

D. MISCELLANEOUS FEATURES OF THE RDR 1500B RADAR SEARCH

Many technical and operational characteristics comprise this radar system. Others such as the flight altitude were determined by the analysis of different performance graphs plotting the relationship of the target RCS vs. Ranges. Also, they show the approximated minimum and maximum ranges at different altitudes. Figure 13 shows this relationship when the radar system is at an altitude of 200 ft. Appendix shows the graphs for altitudes of 500 ft, 1000 ft, 1500 ft and 2000 ft.

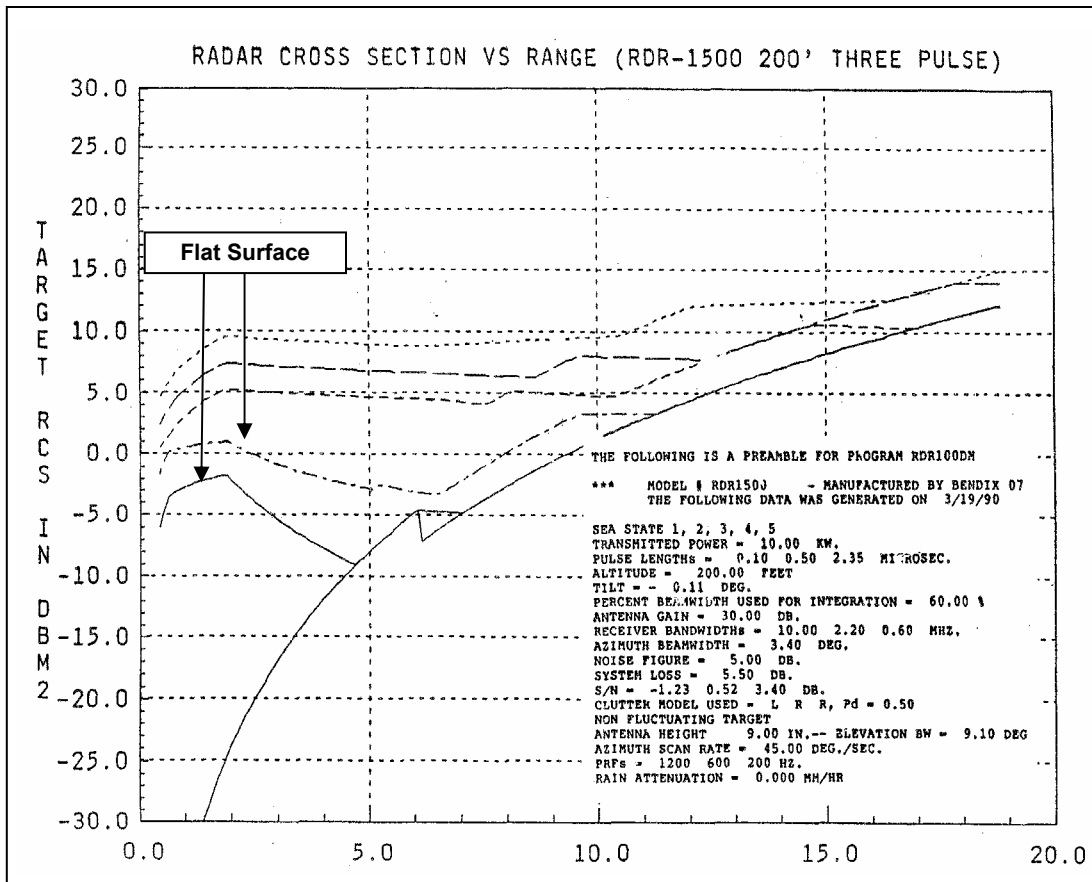

Figure 13. RCS vs. Ranges at 200 Feet

This performance graph and those appearing in the Appendix show some important information when compared with the result obtained from the equations. For instance, the minimum and maximum detection ranges are very similar depending upon the altitude and RCS of the target. In addition, each curve demonstrates a different behavior and represents the different sea states related to the altitude.

Table 5 shows the result obtained applying basic trigonometry. Also the radar horizon can be verified in this table. The equation of the radar horizon shown in the next section of this chapter (Equation 3.7) calculated these radar horizon values.

Altitude (feet)	Altitude (nm)	Tilt Angle (τ)	Elev Angle (ϕ)	α	α (Rad)	$\tan(\alpha)$	R_{min} (nm)	R_n (nm)
200	0.033	0.110	5.250	5.360	0.094	0.094	0.351	17.11
500	0.082	0.170	5.250	5.420	0.095	0.095	0.867	27.06
1000	0.165	0.240	5.250	5.490	0.096	0.096	1.712	38.26
1500	0.247	0.290	5.250	5.540	0.097	0.097	2.545	46.86
2000	0.329	0.340	5.250	5.590	0.098	0.098	3.363	54.11

Table 5. Tilt and Elevation Angles, Minimum Range and Radar Horizon

E. OPERATIONAL CHARACTERISTICS OF THE CASA 212 S43 AIRCRAFT

Operational characteristics are established in the aircraft manual. To develop the model for this thesis, the required characteristics were search speed, flight altitude, search area, and flight time.

To be able to analyze the model, it is important to know and understand certain additional information about aircraft performance. The CASA 212 S43 has a maximum fuel capacity of 5,229 pounds. The fuel consumption, based on the CASA 212 S43 aircraft table of performance and using the operational characteristics depicted below in Table 10, is 757 pounds per hour [15].

Assuming that the aircraft has its maximum fuel capacity, each sortie has approximately a flight time of 6.9 hours [15], but due to internal regulations in the Venezuelan Naval Aviation Command, it is established that 45 minutes must be calculated for an alternate airport in case of adverse weather conditions or another situation that requires going to a different airport [8]. Thus, each sortie in this research has a maximum flight time of 6.15 hours.

Operational Characteristics	
Flight Altitude	200 ft
Search Speed	146 Knots

Table 6. CASA 212 S43 Aircraft Operational Characteristics

1. Searching Operational Speed

When this aircraft operates in search missions, the manufacturer's recommended speed stated in the operation flight manual is 146 knots [3]. It is

calculated by performance tables added in the operation flight manual and represents the best velocity to maneuver the aircraft at a set altitude to reduce the fuel consumption, an important factor to maximize search time in a determined area.

2. Flight Altitude

Flight altitude interacts directly with the aircraft's operational employment as well as its radar capabilities. Operational employment is affected because endurance is related to the flight altitude. In other words, flying at a low altitude increases fuel use, while flying at high altitude is more fuel efficient. Due to this relationship, flight altitude affects the time available on station.

The Navy Operational Manual in the Venezuelan Navy establishes 1000 feet as the search altitude when using an airplane in antisubmarine warfare missions [8]. However, in this case, where the effectiveness of the RDR 1500B search radar versus the submarine periscope area is being evaluated, it is mandatory to require the use of graphs of radar performance for targets of different radar cross sections to establish the best flight altitude [2]. In other words, the flight altitude should be set based on the size of the target.

For example, based on the graphs of radar performance, a flight altitude of 200 ft, gives better detection capability for small radar cross section targets than an altitude of 1000 ft. The model in this thesis has the capability to be varied to observe the resulting change of the measures of effectiveness for different altitudes.

3. Search Area

This parameter represents the area within which the target is assumed to be operating, and where search is conducted. It is within the Venezuelan Caribbean Sea. The model allows the user to vary search area size and examine the resulting probability of detection.

4. Radar Horizon

The radar horizon (R_h) is another important parameter obtained from basic radar theory [14]. Equation 3.7 provides the result in nautical miles for a given antenna height (h), in this case aircraft altitude, set in feet. Since the target is a

diesel submarine periscope (effectively at sea level), the R_h only depends on the aircraft altitude. Using 200 ft altitude, we find a radar horizon of 17.11 nm.

$$R_h \text{ (nm)} = 1.21\sqrt{h \text{ (ft)}} \quad (3.7)$$

THIS PAGE INTENTIONALLY LEFT BLANK

IV. DETECTION RATE MODEL APPLIED TO RDR 1500B SEARCH RADAR

This chapter describes the detection rate model. This model was developed in a spreadsheet based on the available information about the RDR 1500B search radar and the missions established in Chapter II.

A. DETECTION RATE MODEL OVERVIEW

In this thesis, a detection rate model is developed in order to analyze the effectiveness of radar search for a submarine that is only detectable during occasional periods of periscope exposure.

The idea underlying the detection rate is that the rate at which detections can be made is governed by the rate at which occasional periscope exposures occur. Then, when an exposure occurs, it can result in detection if the searching aircraft radar happens to be covering the patch of ocean where the submarine periscope happens to be and the submarine does not evade due to counter-detection. This idea is summarized as follows:

$$\left[\begin{array}{c} \text{Detection} \\ \text{Rate} \end{array} \right] = \left[\begin{array}{c} \text{Rate of submarine} \\ \text{periscope exposure} \\ \text{opportunities} \end{array} \right] * P \left[\begin{array}{c} \text{Aircraft radar} \\ \text{detection patch} \\ \text{is covering spot} \\ \text{when periscope} \\ \text{exposure occurs} \end{array} \right] * P \left[\begin{array}{c} \text{Submarine does} \\ \text{not avoid detection} \\ \text{due to radar} \\ \text{counter-detection} \end{array} \right]$$

The periscope exposure rate or detection opportunity rate is computed based on user inputs concerning the submarine operating profile, such as hours per day at periscope depth for recharging batteries, communicating, or looking at surface ships. The current version of this model computes a constant opportunity rate, but the model could be easily adapted to allow for an opportunity rate that varies by time of day, for example.

In this thesis, the probability that the searching aircraft radar happens to be covering the patch of ocean where the submarine periscope happens to be is called the *radar detection patch coverage probability*. The radar detection patch coverage probability is simply the ratio of the area of the effective radar patch to the search area within which a submarine is assumed to be operating. It is assumed that the uncertain submarine position, when exposed, is equally to be likely anywhere in the search area. The size of the effective radar patch is determined using actual radar capabilities vs. targets of different radar cross sections, which also depends on search aircraft altitude.

Lacking actual data on periscope radar cross-section, which if available would likely be classified, radar cross-section is computed using the physics of radar reflection, assumptions about exposed periscope height and shape, and assumptions about sea surface radar reflection in various sea states. The model could use actual submarine periscope radar cross section data if it were available.

In developing the overall model, it was convenient to consider that the searching aircraft lays down a pattern of discrete non-overlapping radar patches. The time it takes the aircraft to fly over one patch, which depends on the specified aircraft search speed and the length of the patch, provides a convenient time step for computations within the model, and a natural time unit with which to derive the periscope exposure rate or detection opportunity rate.

The probability that the submarine does not avoid detection because it counter-detected the radar before the radar detected the submarine is obtained by calculating two areas, and taking a ratio. First is the area of the radar detection patch, within which the submarine will be detected if it is caught in that patch of area. The second is the total area inside the airborne radar horizon, within which the submarine can counter-detect the airborne radar. The difference between these two areas represents an area within which the submarine can detect the radar emission, but the airborne radar cannot see the much smaller radar reflection. This affords the submarine a chance to submerge

and avoid being caught with exposed periscopes. The ratio of the detection patch area to the radar horizon area thus represents the probability of no submarine evasion due counter-detection.

A more concise summary of the detection rate idea is thus,

$$\left[\begin{array}{c} \text{Detection} \\ \text{rate} \end{array} \right] = \left[\begin{array}{c} \text{Periscope} \\ \text{exposure} \\ \text{rate} \end{array} \right] * P \left[\begin{array}{c} \text{Radar} \\ \text{patch} \\ \text{coverage} \end{array} \right] * P \left[\begin{array}{c} \text{No} \\ \text{counter-detection} \\ \text{evasion} \end{array} \right]$$

Details of each of the parts of the model development are described in the following sections.

B. DETECTION RATE MODEL THEORY

Detection rate models are commonly used in search and detection theory for continuous-looking search (see, for example, Wagner, et. al. [1] or Washburn [10]). They are based on Poisson Processes with either a constant rate parameter, or a rate parameter that varies with time, in which case the process is called non-homogeneous (see, for example, Ross [17]).

To summarize the general theory, let $\gamma(t)$ denote the detection rate at time t . Two assumptions form the basis of detection rate models:

(1) At any time $t \geq 0$, for a small interval of time $h > 0$,

$$P\{\text{at least one detection occurs in } [t, t+h]\} \approx h \gamma(t), \quad (4.1)$$

and the probability of two or more detections occurring in $[t, t+h]$ is negligible compared to $h \gamma(t)$.

(2) Occurrences of detections in non-overlapping time intervals are probabilistically independent.

The general result is an expression for the cumulative detection probability as a function of time, CDP(t).

$$\text{CDP}(t)=1-e^{-\int_0^t \gamma(u) du} \quad (4.2)$$

It can be further noted that the term in the exponent incidentally gives a result for the mean number of detections in (0, t):

$$E[\text{ number of detections in } (0,t)]=\int_0^t \gamma(u) du \quad (4.3)$$

If the detection rate is constant, i.e., $\gamma(t)=\gamma$, then the results are simplified.

$$\text{CDP}(t)=1-e^{-\gamma t} \quad (4.4)$$

$$E[\text{ number of detections in } (0,t)]=\gamma t \quad (4.5)$$

Furthermore, with a constant detection rate γ , the time to initial detection is an exponential random variable, and the mean time between detection events is $1/\gamma$.

The general theory of detection rate models applies to the problem addressed in this thesis, submarine periscope detection by the RDR 1500. The current version of the model computes a constant detection rate, but the model could be easily adapted to allow for a detection rate that varies with time.

Another useful theoretical property of detection rate models is that (Poisson) detection rates add. If the detection rate for a type 1 target is γ_1 , and the detection rate for a type 2 target is γ_2 , then the overall detection rate for any target of type 1 or type 2 is $\gamma = \gamma_1 + \gamma_2$. The current version of the model developed in this thesis is for a single target type with a specified periscope exposure profile, for the sake of simplicity, but the model could be easily adapted to multiple target types representing several periscope exposure profiles.

C. DEVELOPMENT OF THE DETECTION RATE

This section describes in detail the derivation of the elements of the detection rate. Target radar cross section and radar performance measures

such as the minimum and maximum detection ranges and radar horizon were determined in the previous chapter. In this section, the implications of the radar footprint on probability of detection are developed.

1. Periscope Exposure Rate

The periscope exposure rate or detection opportunity rate is computed based on user inputs concerning the submarine operating profile, such as hours per day at periscope depth for recharging batteries, communicating, or looking at surface ships. In this context, any convenient time period can be used to summarize the submarine operating profile that includes time spent completely submerged and time spent with periscopes or masts exposed.

In actual practice, a submarine might use different periscopes or masts for each function. For the sake of simplicity, the current version of this model assumes one common periscope/mast for all functions and aggregates the total time exposed per period. The model could be expanded to consider different periscopes or masts (with different radar cross sections) exposed for differing amounts of time. If different masts were modeled, then it would be appropriate to distinguish exposure times for each unique periscope-mast configuration.

One other simplification used in the current version of the model is to compute a constant periscope exposure rate (or detection opportunity rate); but, it is noted that the model could be easily adapted to allow for an opportunity rate that varies by time of day, for example.

A few terms are defined here, and used to compute the periscope exposure rate:

a. Operational Period

This is any convenient fixed time period used to summarize the submarine operating profile, such as a 24-hour day. An operational period includes time spent completely submerged and time spent with periscopes or masts exposed for any purpose. The model allows the operational period to be input as any number of hours.

b. Periscope Exposure Hours

This is the total expected amount of time during each Operational Period that the submarine has periscopes or masts exposed for any purpose such as recharging batteries, communicating, or making visual observations. Periscope Exposure Hours is a user input.

c. Radar Glimpse Interval

Radar Glimpse Interval is defined here as the time it takes the aircraft to fly over one radar coverage patch, which depends on the specified aircraft search speed and the length of the patch. Equation 4.6 shows this relationship.

$$\text{Radar Glimpse Interval (hrs)} = \frac{\text{Radar Patch Length (nm)}}{\text{Aircraft Search Speed (kts)}} \quad (4.6)$$

d. Glimpse Count

This is computed by the ratio of the Periscope Exposure Hours to the Radar Glimpse Interval. It counts the number of glimpse intervals that comprise Periscope Exposure Hours (during each Operational Period). Equation 4.7 shows this relationship.

$$\text{Glimpse Count} = \frac{\text{Periscope Exposure Hours (hrs)}}{\text{Radar Glimpse Interval (hrs)}} \quad (4.7)$$

Finally, the periscope exposure rate is calculated by dividing the glimpse count (number of glimpses that comprise periscope exposure during each Operational Period) by the duration of an Operational Period. Equation 4.8 shows this relationship.

$$\text{Periscope Exposure Rate (hrs}^{-1}\text{)} = \frac{\text{Glimpse Count}}{\text{Operational Period (hrs)}} \quad (4.8)$$

It is noted that the model does not explicitly use submarine speed as an input, but submarine speed does implicitly determine the rate at which the submarine needs to recharge batteries.

2. Sweep Width and Lateral Range Function

Sweep width for the RDR 1500 when flown at a particular altitude searching for a target of a particular radar cross section is needed for computing the detection rate. Two options exist for determining sweep width.

a. Option One

Option one would assume the radar footprint determined in Chapter 3 acts like a cookie-cutter and thus the overall width of the footprint would be the sweep width. The following discussion describes the reasoning behind this method and concludes that it is not used due to some shortcomings.

Since the radar footprint, Figure 7, was determined based upon the radar ability to see targets within that footprint (and conversely its inability to see targets outside the footprint), the radar footprint could possibly be interpreted as a cookie-cutter detection pattern (i.e., detecting every target that falls within the footprint with probability 1).

Although the shape of the footprint is irregular, as the aircraft moves forward, the radar footprint physically sweeps the area from the left-most corner of the footprint to the right-most corner. Thus, the entire width of the footprint could be optimistically interpreted as a cookie-cutter sweep width and used directly in subsequent calculations. This cookie-cutter sweep width interpretation is called optimistic because of the irregular shape of the radar footprint. In fact, as the radar footprint sweeps over area, points close to the extreme left and right corners of the pattern are within the footprint for much less time than points that are passed closer to the middle of the pattern.

Accordingly, it is deemed unrealistic to treat the full width of the radar footprint as a cookie-cutter sweep width, and therefore this method is not used.

b. Option Two

Option Two is to calculate sweep width as the integral of the lateral range function over all possible closest points of approach between the aircraft and the submarine (i.e., find the area under the radar lateral range curve) [1]. This is the preferred method that is used.

If actual lateral range curves for the RDR 1500B were available from the manufacturer, or from operational testing, they could be used directly. However, lacking such data, a lateral range function can be approximated based on the geometry of the RDR 1500 radar footprint and the proportional amount of time that an exposed target will fall within the footprint as a function of the closest point of approach between the exposed target and the aircraft.

3. Approximation of the Lateral Range Function

Lateral range is the closest point of approach (CPA) between the searcher and the target assuming a straight line relative motion path as illustrated in Figure 14. The lateral range function, $L(x)$, is a cumulative detection probability as a function of the lateral range x [1]. These definitions implicitly assume that a target exists that can be detected. In the context of this thesis, the target would be an exposed submarine periscope. Accordingly, the cumulative probability of detection used in the lateral range function might more correctly be called a conditional cumulative probability of detection given that the submarine periscope is exposed. This is very significantly different from the cumulative detection probability that will ultimately be computed based on intermittent submarine periscope exposure and counter-detection evasion.

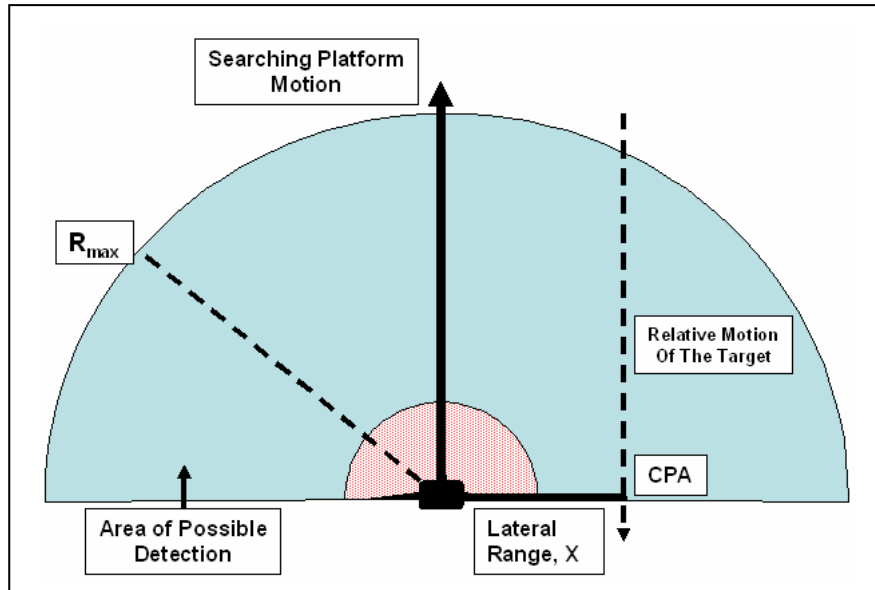

Figure 14. Lateral Range (CPA)

To construct the lateral range curve, it is assumed that the sensor capability depends on the maximum detection range (R_{max}), the amount of time an exposed target would be inside the radar footprint, and whatever the detection rate is for an exposed target.

As can be seen in Figure 14, when CPA range $x \leq R_{max}$, the target could be detected and when CPA range $x > R_{max}$ the target is not detectable.

Figure 15 illustrates the relative motion path of the target through the radar footprint starting from when the target enters in the area of possible detection at point (x, y_0) . The location of the target at time t is $(x, y(t)) = (x, y_0 - vt)$, where v is the relative speed. It may be noted that in the context of this thesis, submarine speed is very slow compared to aircraft search speed and thus relative speed is approximately just the aircraft speed.

In this case, the target reaches its CPA at time $t = y_0 / v$ and moves out of the area of detection.

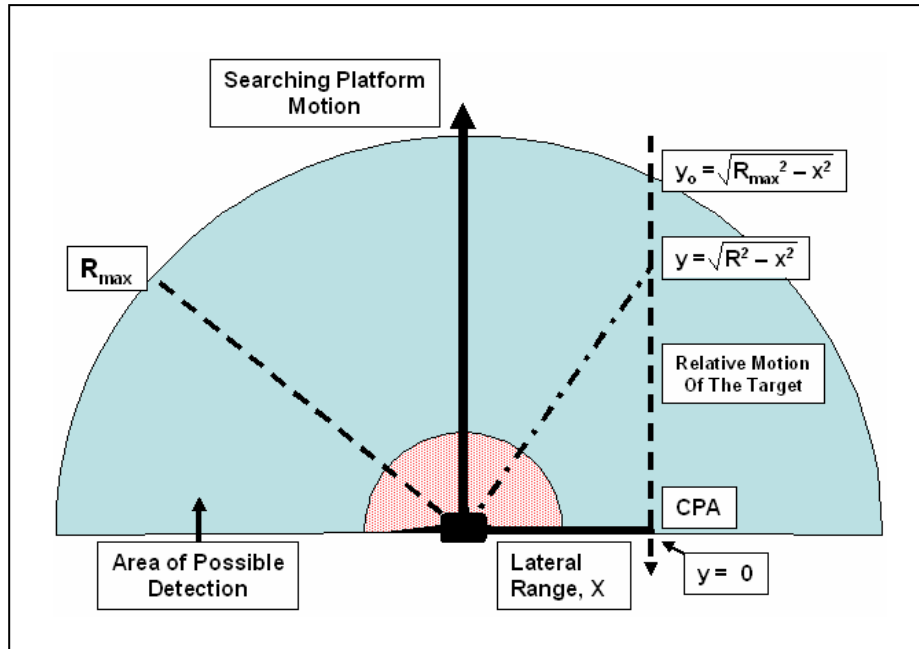

Figure 15. Relative Motion of Target

Wagner [1] derives a lateral range function for a situation comparable to the situation here. If it is assumed that the RDR 1500 footprint passes over an area containing an exposed submarine periscope, and that during this encounter a constant detection rate applies, then the lateral range function takes the form of Equation 4.9, where K is a constant.

$$L(x) = 1 - e^{(-K(\sqrt{R_{\max}^2 - x^2})/v)} \quad \text{for } x \leq R_{\max} \quad (4.9)$$

For $x > R_{\max}$, $L(x) = 0$.

The maximum value of this lateral range function, when CPA range $x = 0$, is

$$P_{\max} = L(0) = 1 - e^{(-K R_{\max}/v)} \quad (4.10)$$

Thus, it can be seen that the single parameter K affects both the height of the lateral range function and also the shape as it falls off from its maximum value to 0.

In this thesis, the parameter K is treated as a user input to generate an approximate lateral range function that is deemed to be realistic for the given radar and given target radar cross section. The examples that follow are for K=2.9, a common value then applied for all three target sizes shown in Section C of Chapter III.

The obtained lateral range curves for each target are the graphs shown in Figures 16 through 18. They are calculated in the spreadsheet prepared with the application of Equation 4.11, and available data of the RDR 1500B search radar and aircraft.

$$L(x) = 1 - e^{\left(-2.9(\sqrt{R_{\max}^2 - x^2}/V)\right)} \quad (4.11)$$

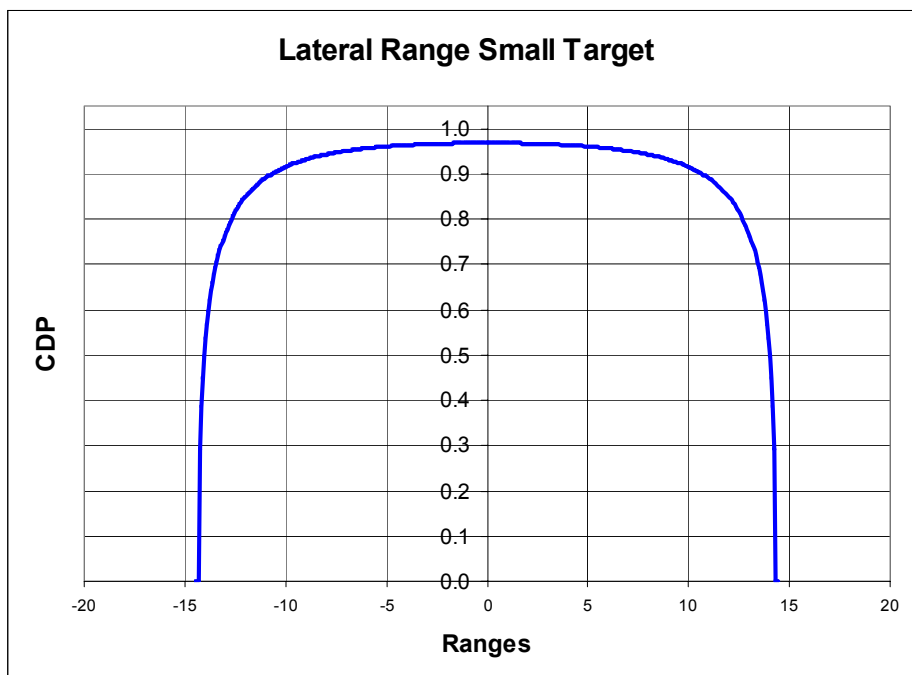

Figure 16. Lateral Range Small Target

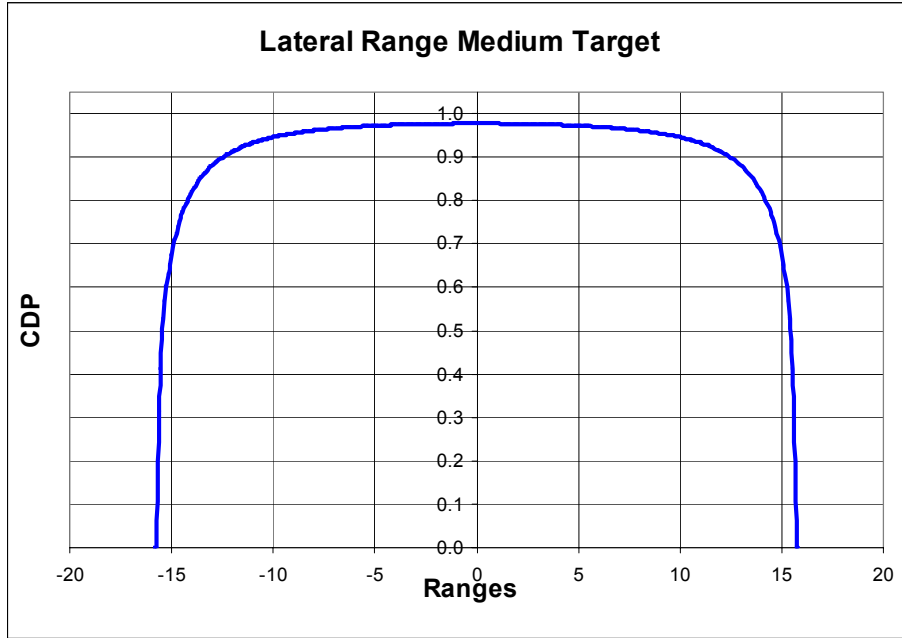

Figure 17. Lateral Range Medium Target

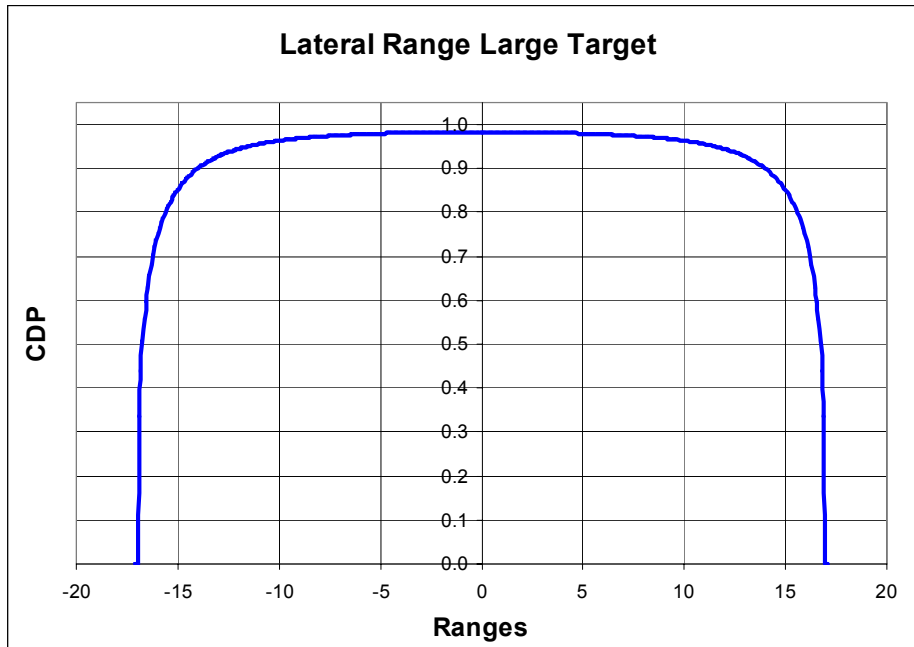

Figure 18. Lateral Range Large Target

These shapes of the three graphs are very similar to each other because they all use the same value for the parameter K . The differences are due to the different maximum ranges, which in turn were due to the different target sizes.

	Small Target	Medium Target	Large Target	Units
$R_{max} =$	14.13	15.48	16.72	Nm
$R_{min} =$	-14.13	-15.48	-16.72	Nm
Area =	12.71	14.17	15.50	Nm ²
Delta_R =	0.07	0.08	0.08	Nm
Height =	1.00	1.00	1.00	Nm
Parameter K =	2.90	2.90	2.90	per hour
Sweep Width (W) =	25.41	28.34	31.01	Nm

Table 7. Lateral Range Curve Data

Table 7 shows the data used to calculate each lateral range curve. Each R_{max} is based on the RCS of the target. The term Area represents the area below the positive half of each curve, which is used to determine the Sweep Width (W) for each target. The parameter Delta_R is the CPA range step used to tabulate the lateral range function. It was established at 0.5% of R_{max} . Parameter K represents the constant, which was assumed to construct each curve that would be similar to an actual lateral range curve for the radar. The Sweep Width Section of this chapter explains the Height and Sweep Width (W) terms.

SMALL TARGET				
-CPA	CPA	L(x)	Area	Total
0.000	0.000	0.968	0.000	0.000
-0.072	0.072	0.968	0.069	0.069
-0.143	0.143	0.968	0.069	0.139
-14.276	14.276	0.291	0.024	12.931
-14.347	14.347	0.000	0.010	12.942
-14.419	14.419	0.000	0.000	12.942

Table 8. Developed Lateral Range Curve Data for a Small Target

MEDIUM TARGET				
-CPA	CPA	L(x)	Area	Total
0.000	0.000	0.977	0.000	0.000
-0.079	0.079	0.977	0.077	0.077
-0.157	0.157	0.977	0.077	0.154
-15.638	15.638	0.314	0.029	14.411
-15.717	15.717	0.000	0.012	14.423
-15.795	15.795	0.000	0.000	14.423

Table 9. Developed Lateral Range Curve Data for a Medium Target

LARGE TARGET				
-CPA	CPA	L(x)	Area	Total
0.000	0.000	0.983	0.000	0.000
-0.085	0.085	0.983	0.083	0.083
-0.170	0.170	0.983	0.083	0.167
-16.891	16.891	0.334	0.033	15.762
-16.976	16.976	0.000	0.014	15.777
-17.061	17.061	0.000	0.000	15.777

Table 10. Developed Lateral Range Curve Data for a Large Target

Tables 8 through 10 represent part of the calculated lateral range function tables, which are also used to obtain the Sweep Width (W). This data was obtained from Equation 4.11.

4. Effective Sweep Width

It is necessary to know the radar sweep width for use in the model. The following equation (Equation 4.12) defines this parameter [1].

$$w = \int_{-R_{max}}^{+R_{max}} L(x) dx \quad (4.12)$$

This parameter is defined as equal to the area under the lateral range curve [1]. In other words, this defines an equivalent cookie cutter lateral range curve with a base of sweep width W and height 1.0 (100%). Since the base has units of distance and the height no units, the sweep width W has units of distance (nm). Figures 19 through 21 show the graphical representations for each target. Each square line represents the sweep width for each target.

The sweep width represents the total area below the lateral range curve. Numerical integration with the trapezoid rule is used to calculate the entire area. This rule was executed with a small step size (Delta_R) set at 0.5% of the R_{max}.

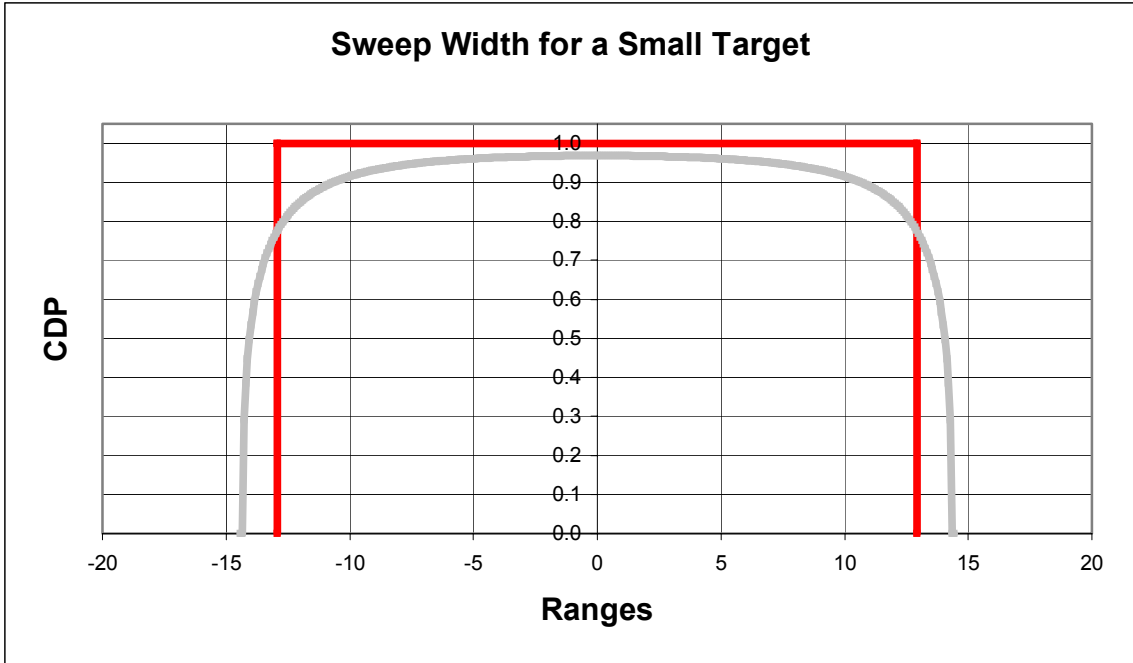

Figure 19. Sweep Width for a Small Target



Figure 20. Sweep Width for a Medium Target



Figure 21. Sweep Width for a Large Target

5. Effective Sweep Rate

Sweep rate is the product between aircraft search speed (v) and the effective sweep width (W), which is calculated independently for each type of target. Sweep rate has units area searched per unit time.

For instance, the sweep rate for one aircraft with a search speed of 146 knots (nm/hour) and the sweep width based on the RCS for a small target and 200 feet of aircraft search altitude of approximately 25.41 nm and sea state zero (0), is roughly 3,710 nm²/hour.

6. Radar Patch Coverage

This parameter is required to calculate the radar detection patch coverage probability to be applied in the detection rate. It is the product between the sweep rate (nm²/hour) and the glimpse interval (hour). The result is the area that the aerial platform covers in interval of time it takes the aircraft to fly the length of a single radar footprint patch. The following equation shows this relationship (Equation 4.13).

$$\text{Radar Patch Coverage} = \text{Radar Glimpse Interval} * \text{Effective Sweep Rate} \quad (4.13)$$

7. Radar Detection Patch Coverage Probability

This represents the likelihood that the relatively small aircraft radar patch happens to be covering the point in the much larger search area when a detection opportunity (i.e., periscope exposure) occurs. It is assumed that the uncertain submarine position, when exposed, is equally likely to be anywhere in the search area. This probability is therefore simply the ratio of the area of the effective radar patch to the search area within which a submarine is assumed to be operating. Equation 4.14 shows this relationship.

$$\text{Radar Detection Patch Coverage Probability} = \frac{\text{Radar Patch Coverage}}{\text{Search Area}} \quad (4.14)$$

8. Counter-Detection by the Submarine

The model considers the possibility that the search radar can be counter-detected by the target submarine. Modeling counter-detection uses the radar maximum detection range (R_{\max}), which depends on the target RCS as well as aircraft altitude, and the associated calculated radar horizon (R_{ho}). Those two ranges form concentric half circles. The difference in these areas represents opportunity for the submarine to make a counter-detection and submerge without being detected. The ratio of that difference to the area within the radar horizon is then the (conditional) probability of submarine submerging before detection, given that he is in a radar horizon patch. The probability of no counter-detection evasion can be obtained by subtracting the probability of evasion from 1, or directly as the ratio of the area of the inner circle (radar detection) to the area of the outer circle (radar horizon).

9. Detection Rate

This parameter represents the most important value required for this research as the model depends on how many opportunities the periscope is exposed to on the sea surface per period of time.

As explained in the overview of the detection rate model, the detection rate idea is summarize in Equation 4.15.

$$\text{Detection Rate} = \left(\begin{array}{c} \text{Periscope} \\ \text{Exposure} \\ \text{Rate} \end{array} \right) * P \left(\begin{array}{c} \text{Radar} \\ \text{Patch} \\ \text{Coverage} \end{array} \right) * P \left(\begin{array}{c} \text{No} \\ \text{Counter-detection} \\ \text{Evasion} \end{array} \right) \quad (4.15)$$

Since the current version of the model computes a constant periscope exposure rate (or detection opportunity rate), and the two probabilities in Equation 4.15 are also constants, the resulting detection rate is constant. The constant detection rate thus obtained is then used with Equation 4.4 to calculate cumulative detection probability for the search.

It is noted that the model could be easily adapted to allow for a detection rate that varies by time of day, for example. In this case, Equation 4.2 would be used to evaluate cumulative detection probability after using numerical integration to evaluate Equation 4.3.

V. ANALYSIS OF THE RESULTS

This chapter analyzes results obtained using the detection rate model applied to the RDR 1500B search radar installed in the CASA 212 S43 aircraft. The analysis is based on using cumulative detection probability (CDP) as a function of hours of search as the principal measure of operational effectiveness for the search. It is convenient to examine the plot of cumulative detection probability versus time, $CDP(t)$ to see graphically how rapidly or slowly CDP grows with time for different operational situations. The plots allow tactical decision makers to answer questions of interest easily for each situation, such as:

- How many hours of search are needed to reach a CDP of .5?
- What CDP can be achieved in a single sortie of 6.15 hours? In 24 cumulative hours of search? In 48 hours? etc.

The analysis in this chapter reflects variations in the following user inputs to the model:

- search area size
- number of searching aircraft
- submarine periscope exposure time
- sea-state
- submarine counter-detection of the radar

All the cases analyzed also reflect various periscope heights above the sea surface, called small, medium, and large targets. Aircraft search altitude and speed are fixed in this analysis, but any of these parameters could be changed for further investigation.

A. OPERATIONAL SEARCH AREA

The analysis is initiated by making different combinations based on the total searching area and the number of aircraft used. The periscope exposure hours is kept to three (3) hours. Based on the total area, this is the best method to analyze the resulting plot of CDP as a function of hours of search to obtain a

search area size in which either one or two aircraft could make this type of mission. Starting with a fairly large area, reductions in search area size are made until a reasonably useful CDP can be achieved based on a single aircraft sortie time of 6.15 hours.

1. Total Search Area of 125,000 nm² and One Aircraft

Figure 22 shows the situation as applied to the entire Venezuelan Caribbean Sea, in which the water extension is approximately 125,000 nm² when using an aircraft. Based on this graph and using the operational characteristics shown in Table 6, it is possible to analyze the resulting plot of CDP as a function of hours of search.

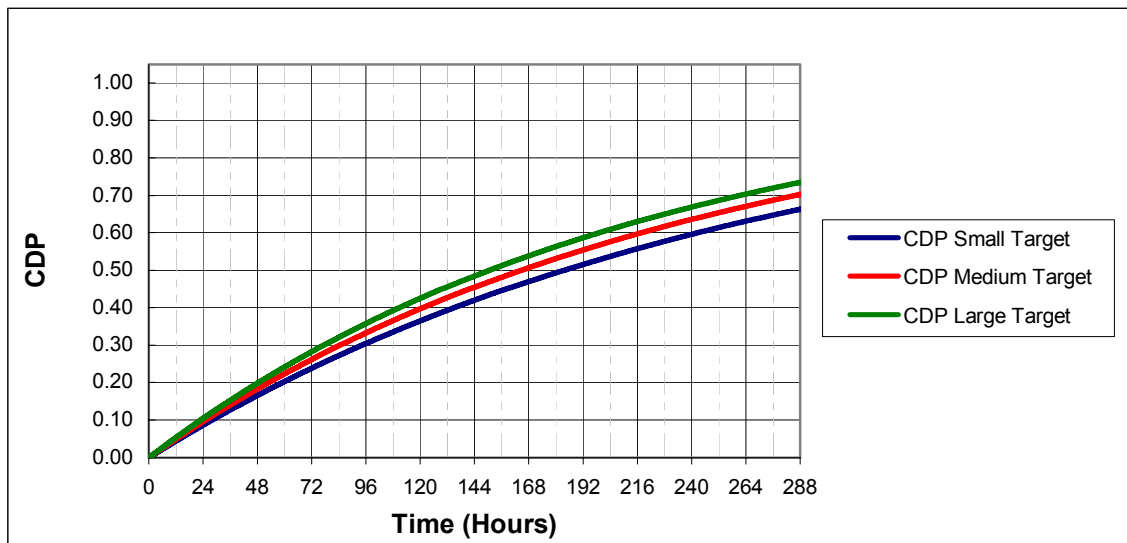

Figure 22. CDP vs. Time Using 125,000 nm² and One Aircraft

These three CDP curves represent each type of target. To obtain a CDP of at least .5 requires many hours of search effort, which would take many aircraft sorties over long periods of time. These periods of time are 183.5 hours, 164.7 hours, and 150.5 hours, respectively. In this case, approximately .03 probability of detection could be obtained in a single sortie lasting 6.15 hours.

2. Total Search Area of 125,000 nm² and Two Aircraft

In this situation a second aircraft is added to search concurrently with the first aircraft within the same search area. They can be flying coordinated patterns, or completely independently, with the only assumption being that their

two radar patches do not simultaneously look at the exact same spot. Adding the second aircraft therefore doubles the detection rate. Figure 23 shows the results.

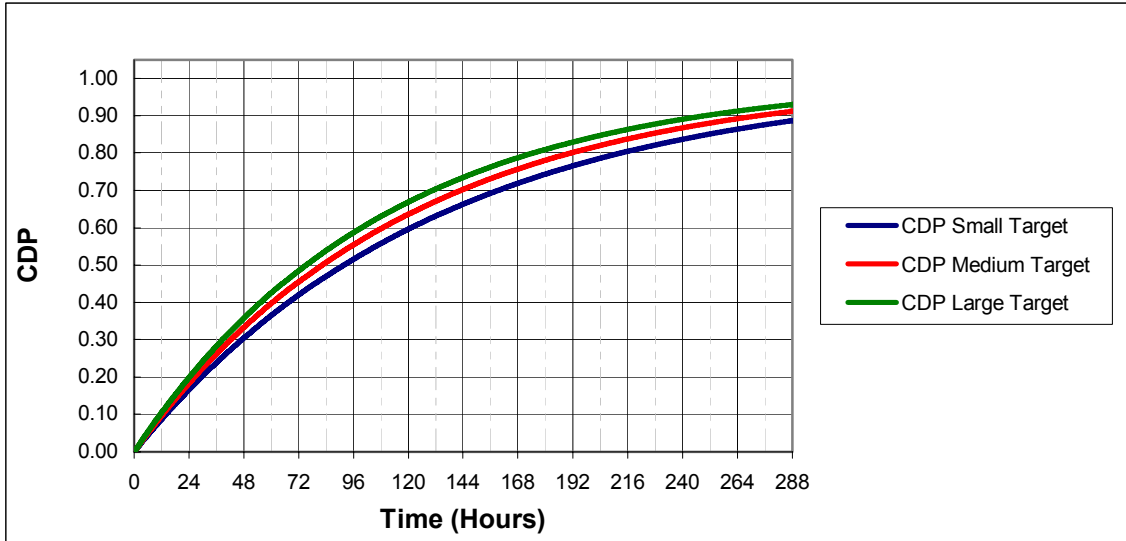

Figure 23. CDP vs. Time Using 125,000 nm² and Two Aircraft

Observing the graph, it is seen that CDP increases much more rapidly, but is still very low after one sortie with both aircraft. At 6.15 hours CDP is approximately .05. A cumulative probability of detection of .5 is achieved at 91.8 hours, 82.8 hours, and 75.7 hours, respectively. For a search area this large, these times equate to 13-15 two plane sorties, which takes roughly three to four days to get up to .5 probability of detection. Better results could be obtained if the search area can be reduced.

3. Total Search Area of 62,500 nm² and One Aircraft

This area size represents a 50% reduction of the original area, i.e., the uncertain area within which the submarine is assumed to be operating is half the size previously analyzed. Figure 24 shows the resulting plot of CDP obtained for this area.

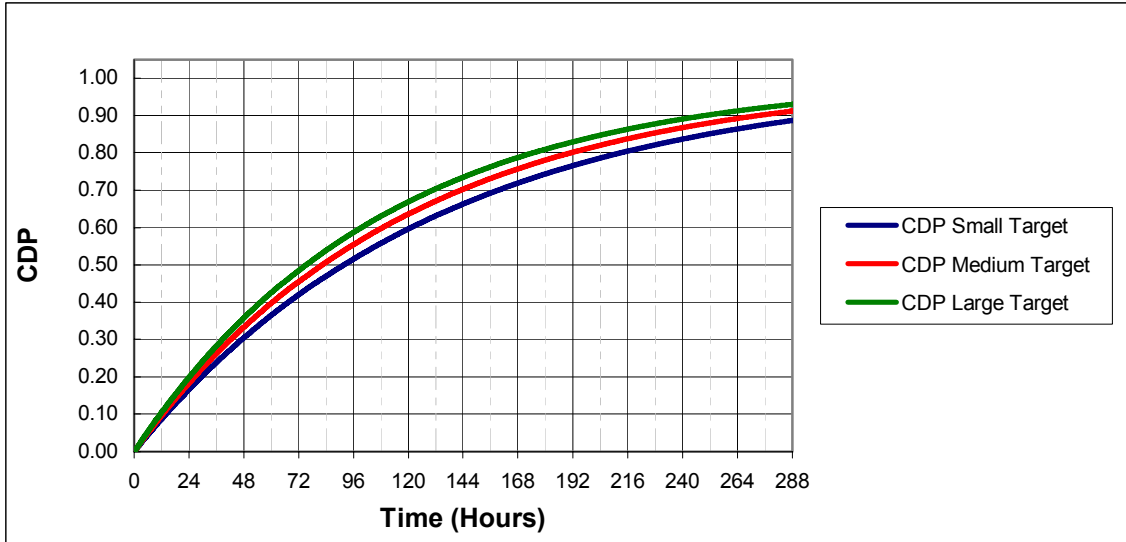

Figure 24. CDP vs. Time Applying 62,500 nm² and One Aircraft

These results are, of course, the same as the previous case, which was for two aircraft searching twice the area. Another interpretation is that this result demonstrates that halving the search area effectively doubles the detection rate.

4. Total Search Area of 62,500 nm² and Two Aircraft

In this situation, the search area size is kept the same as the previous situation. The difference is that the number of aircraft is increased to two. These CDP curves should be higher than before because the search area coverage is doubled in the same period of time, i.e., the detection rate is doubled again. Figure 25 shows these CDP curves.

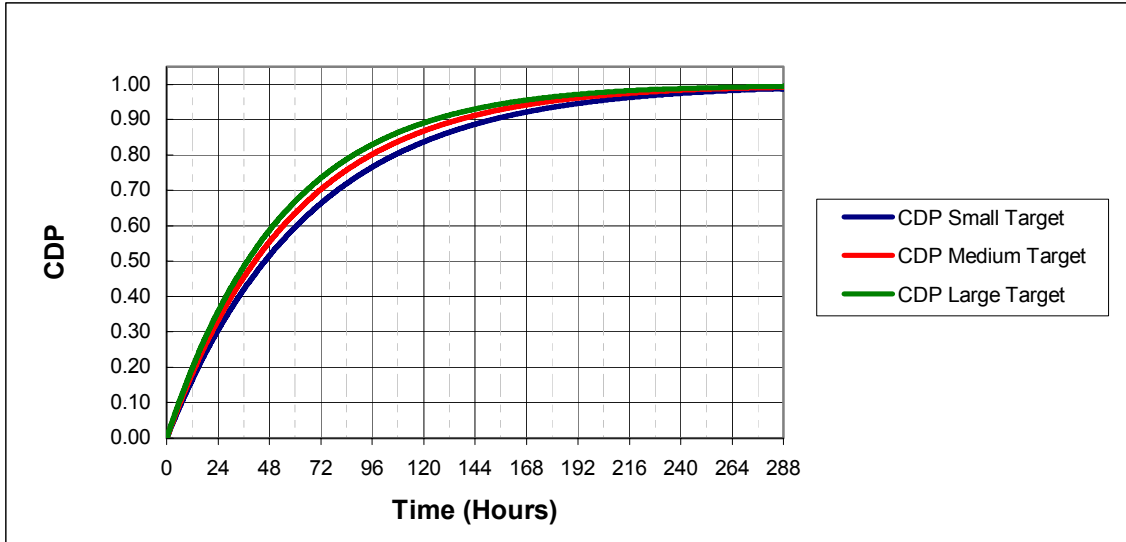

Figure 25. CDP vs. Time Applying 62,500 nm² and Two Aircraft

The graph shows that the results are much better with a single sortie of 6.15 hours for two aircraft, at which point the CDP is approximately .11. The elapsed search time, with both aircraft searching simultaneously, to obtain a .5 CDP are 46.0 hours, 41.3 hours, and 37.7 hours, respectively.

5. Total Search Area of 31,200 nm² and One Aircraft

This search area size is 50% of the previous area with one aircraft searching. Figure 26 shows the graphical results. These results are the same as the previous case, which was for two aircraft searching twice the area.

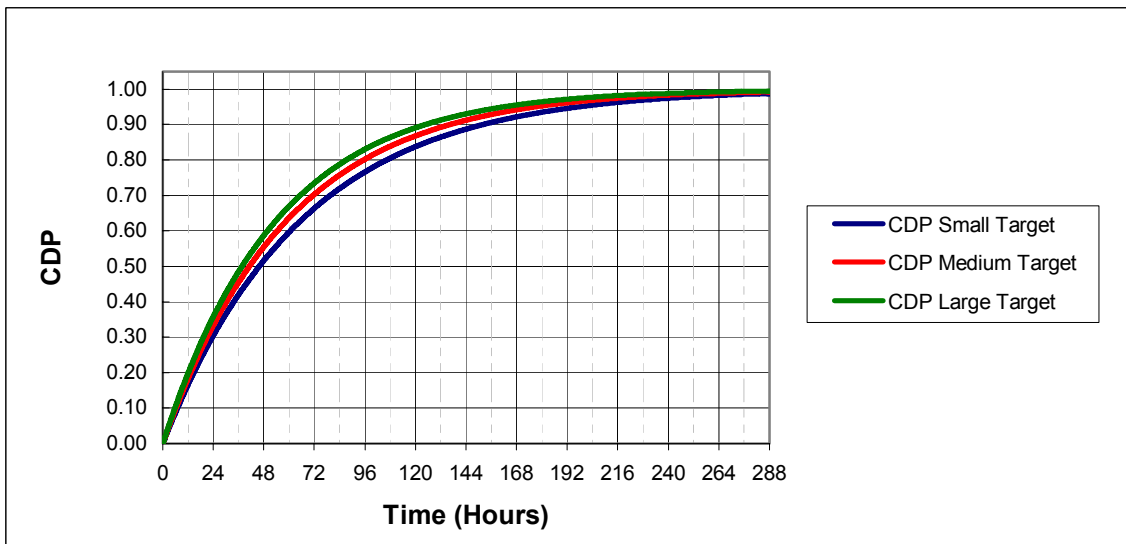

Figure 26. CDP vs. Time Applying 31,200 nm² and One Aircraft

6. Total Search Area of 31,200 nm² and Two Aircraft

This situation is the same search area as the previous case with two simultaneous searchers. Figure 27 shows this combination.

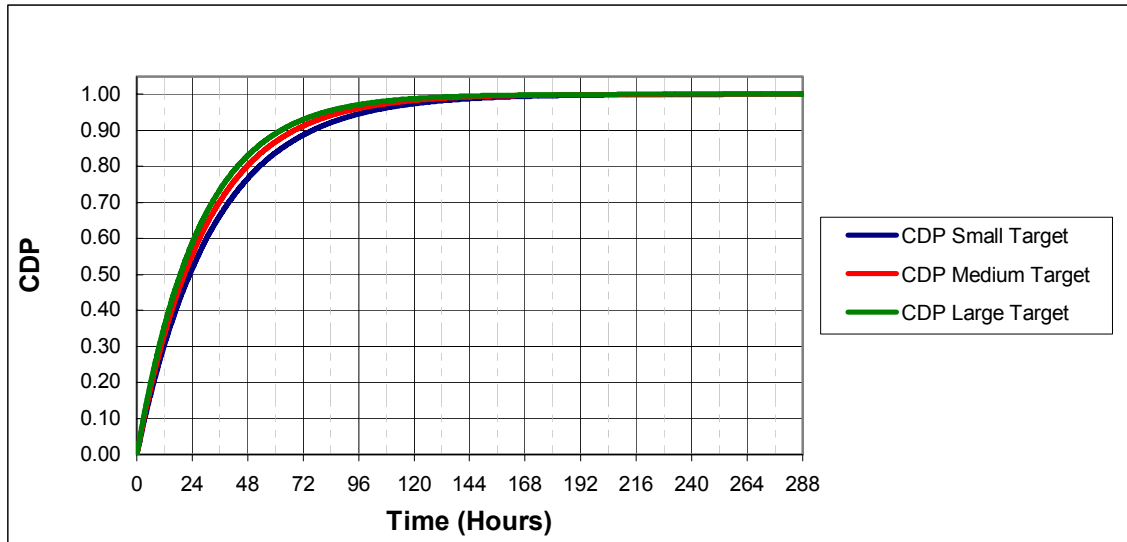

Figure 27. CDP vs. Time Applying 31,200 nm² and Two Aircraft

In this combination, the resulting plots are much better. Less than 24 hours are required to obtain at least the .5 CDP. For the three target sizes the search times are 23.0 hours, 20.6 hours, and 18.9 hours, respectively. Also, for a sortie time of 6.15 hours, CDP is approximately .2.

7. Total Search Area of 15,600 nm² and One Aircraft

This combination is created using one aircraft and reducing the search area by half, as before. The result is again the same as for twice the area searched with twice the aircraft. Figure 28 shows this combination.

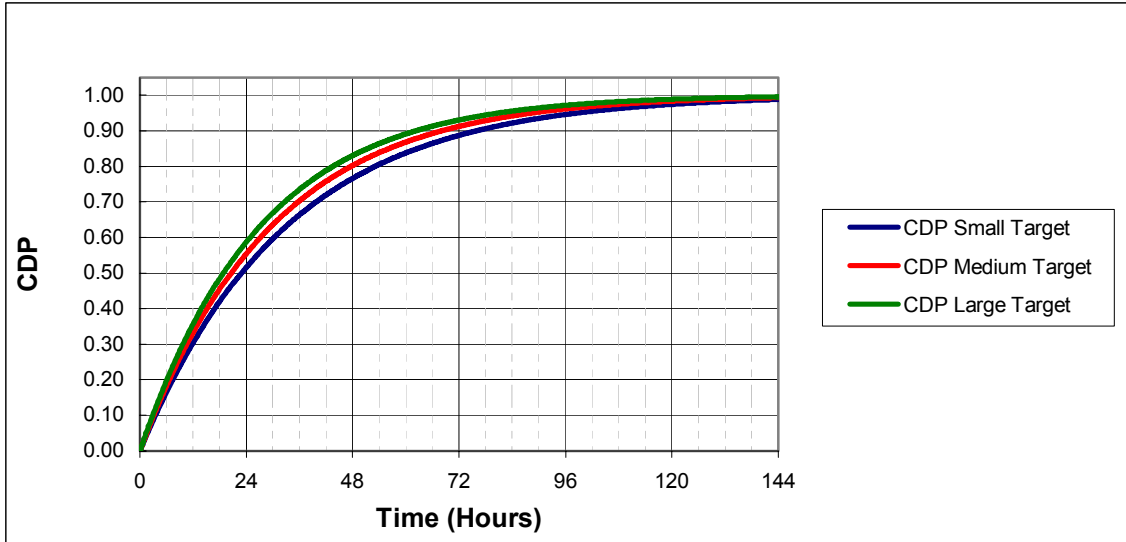

Figure 28. CDP vs. Time Applying 15,600 nm² and One Aircraft

The combination using the same search area size with two aircraft will not be shown because the result is the same as the following case reduction of the search area by half again.

8. Total Search Area of 7,800 nm² and One Aircraft

Figure 29 shows the results for this search area and only one aircraft.

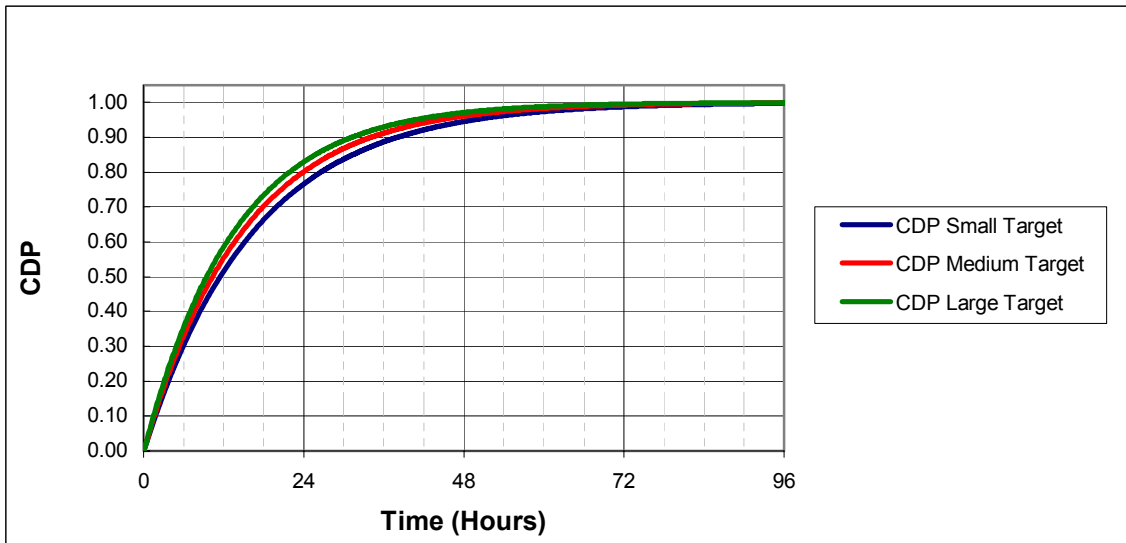

Figure 29. CDP vs. Time Applying 7,800 nm² and One Aircraft

Observe that the results in this graph are better. A sortie time (6.15 hours) obtains a CDP of .34. The periods of time to obtain a CDP of .5 are 11.5 hours,

10.42 hours, and 9.45 hours, respectively. It can be anticipated that with two aircraft or reducing the search area in half again, the result should be a CDP of more than .5 for one sortie time.

9. Total Search Area of 3,900 nm² and One Aircraft

This combination shows a reduction to half the previous search area with a single searching aircraft. This area corresponds to 60nm by 65 nm, but could be other shapes. Figure 30 shows the results for this combination.

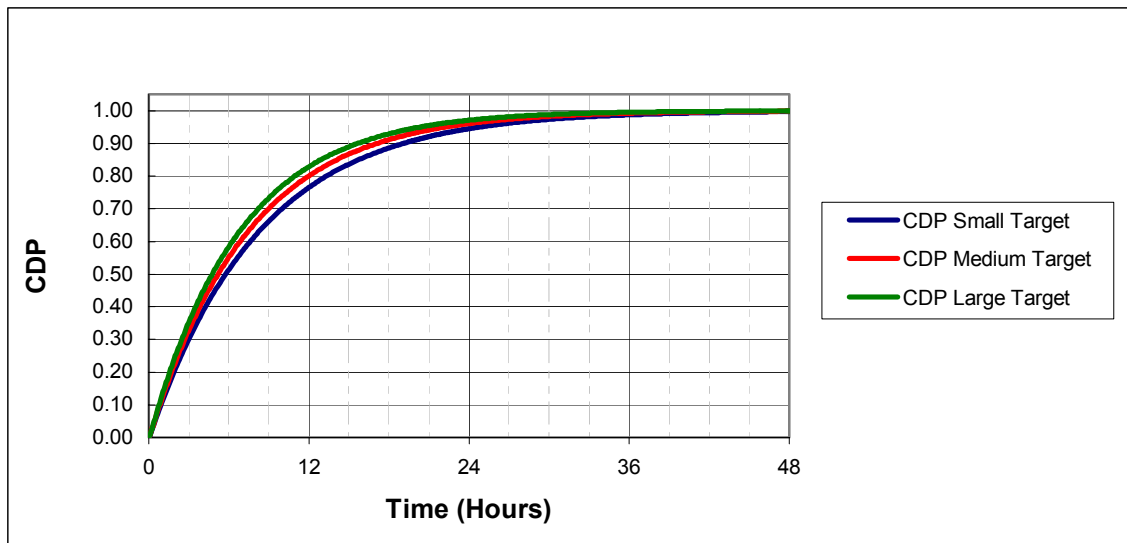

Figure 30. CDP vs. Time Applying 3,900 nm² and One Aircraft

The resulting plot of CDP as a function of hours of search looks very good. The situation achieves better than .5 probability of detection with a single sortie time (6.15 hours). For the three size targets, the CDP results for 6.15 hours are .52, .56, and .59, respectively.

B. PERIOD OF TIME TARGET PERISCOPES OR MASTS EXPOSED ABOVE THE SEA SURFACE

This section obtains different CDP curves based on the periscope exposure hours. These periods of time are based on general diesel submarine characteristics, such as time required for the battery recharge process,

communications process and tactical observations. These periods of time are varied from a baseline of 3 hours exposed per 24 hour operational period up to 12 hours exposed per 24 hour period.

In this section, the search area size is $3,900 \text{ nm}^2$, and one aircraft is used.

1. Three-Hour Exposure

This combination represents the same situation shown in the last part of the previous section.

2. Six-Hour Exposure

In this combination, periscope exposure hours are doubled. Figure 31 shows the results.

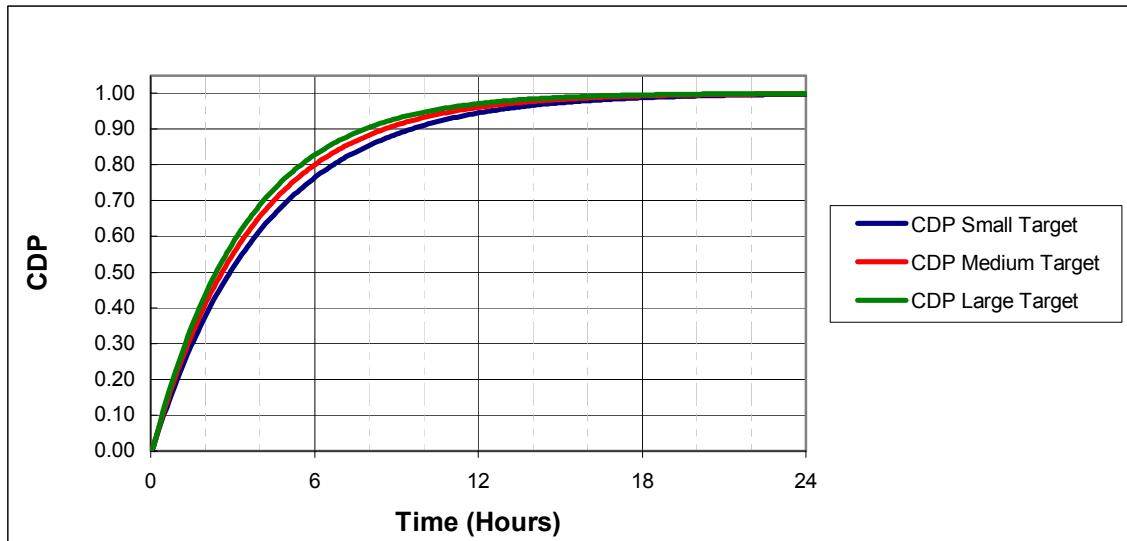

Figure 31. CDP vs. Time Applying $3,900 \text{ nm}^2$ and Six-Hour Exposure

This graph looks very good because the resulting plots have an excellent cumulative detection probability. For a single sortie time (6.15 hours), they are .77, .80, and .83 for the three target sizes studied. It is noted that doubling periscope exposure hours effectively doubles the detection rate and that these results are equivalent to doubling the number of searchers, or halving the search area as was done in the previous section.

3. Nine-Hour Exposure

In this situation, the periscope exposure hours are increased to nine (9), which represents 37.5% of an operational period of 24 hours. This effectively triples the baseline detection rate. Figure 32 shows the results for this combination.

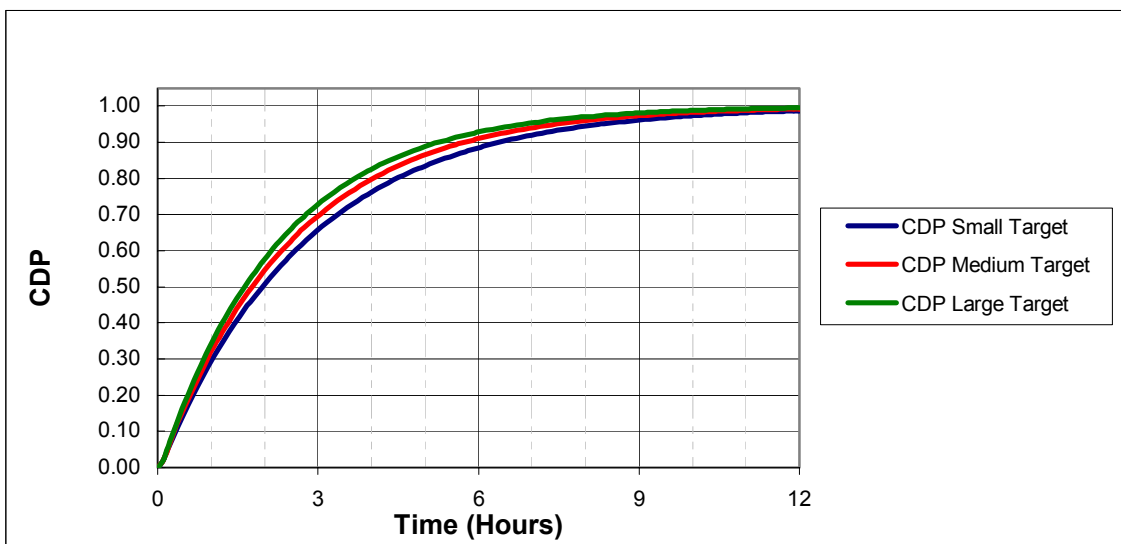

Figure 32. CDP vs. Time Applying 3,900 nm² and Nine-Hour Exposure

From this graph, the resulting plots show single sortie CDP of .89, .91, and .93, respectively. These results from an aircraft represent an excellent probability of detection of a small target.

4. Twelve-Hour Exposure

In this situation, the periscope exposure hours is increased to a half day (12 hours), which produces four times the baseline detection rate. Figure 33 shows the results for this combination.

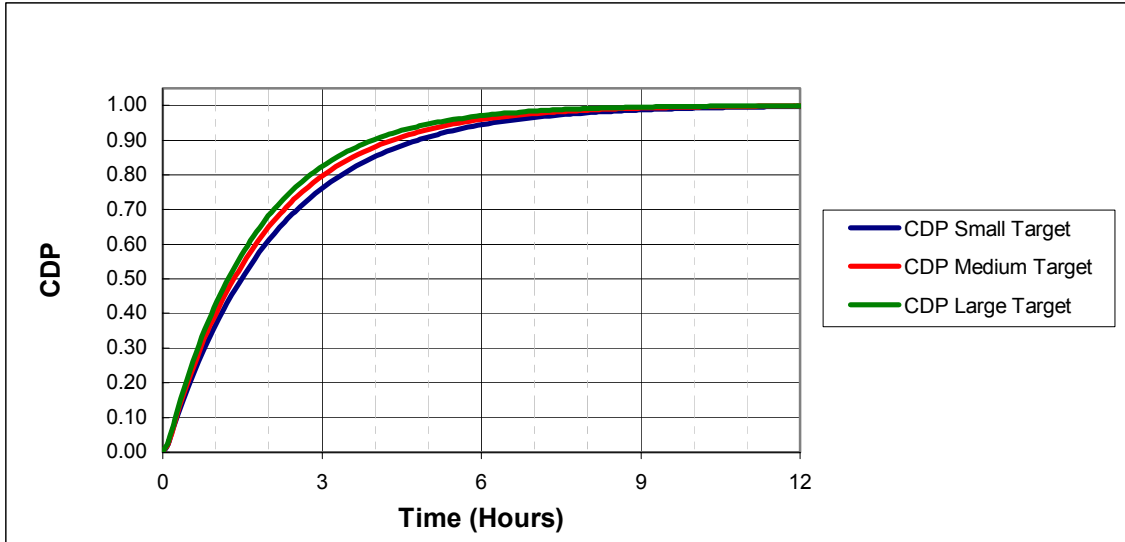

Figure 33. CDP vs. Time Applying 3,900 nm² and Twelve-Hour Exposure

This situation is much better than before. The results are CDP of .95, .96, and .97, respectively, for one sortie time (6.15 hours).

C. SEA STATE CORRECTION FACTOR APPLICATION

This section shows the application of the correction factors (Table 3) to adjust the submarine periscope radar cross sections for sea states other than sea state zero. The consequences are shown in the graphical representations of the CDP as a function of search time.

The analysis was conducted using a single aircraft, keeping the search area size (3,900 nm²) and applying the sea state correction factors in situations when periscope exposure hours are three (3) and twelve (12).

1. Three-Hour Exposure at Sea State Smooth

This situation relates three (3) hours that the target is above the surface, and the sea state one (1), in which correction factor applied is 90%. This correction factor directly affects the RCS of the target, and indirectly, the lateral range curves and maximum ranges. Figure 34 shows the resulting CDP.

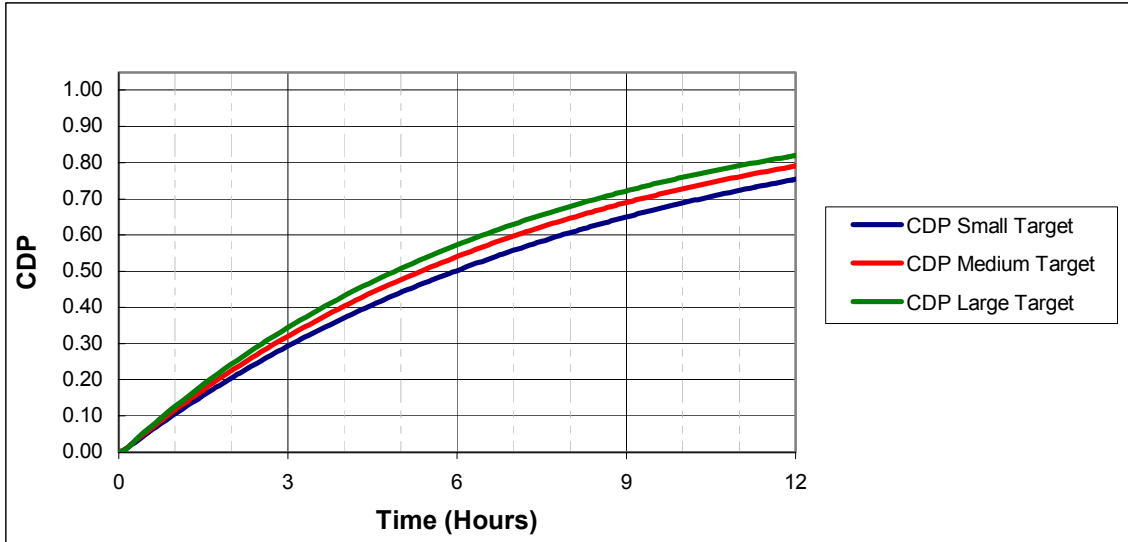

Figure 34. Three-Hour Exposure at Sea State Smooth

With this application of the sea state 1 correction, the resulting CDP for a single sortie time is reduced by approximately .01 compared with the sea state zero case, which was shown in Figure 30.

2. Three-Hour Exposure at Sea State Moderate

In this situation, the sea state 3 correction is applied (the RCS reduction is 50%). Figure 35 shows the results for this combination.

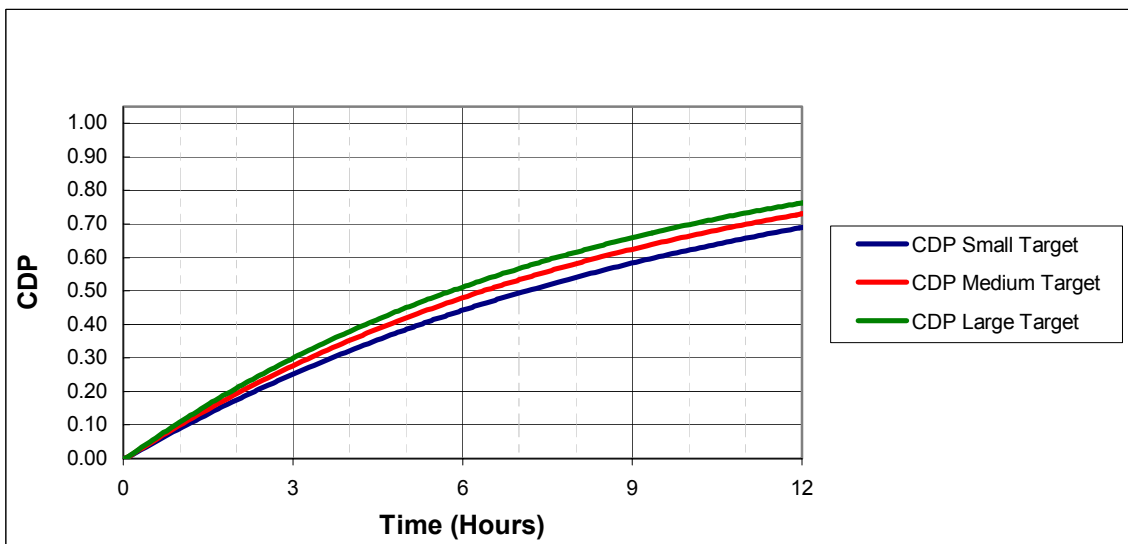

Figure 35. Three-Hour Exposure at Sea State Moderate

In this situation, each CDP at one sortie time (6.15 hours) is reduced almost .07. This case is an example showing the probability of detection affected by weather conditions.

3. Three-Hour Exposure at Sea State Rough

In this situation, the correction for sea state 4 is applied and the RCS is only 15% of its original value. This reduction is due to the waves being higher than the submarine periscope. Figure 36 shows the results for this combination.

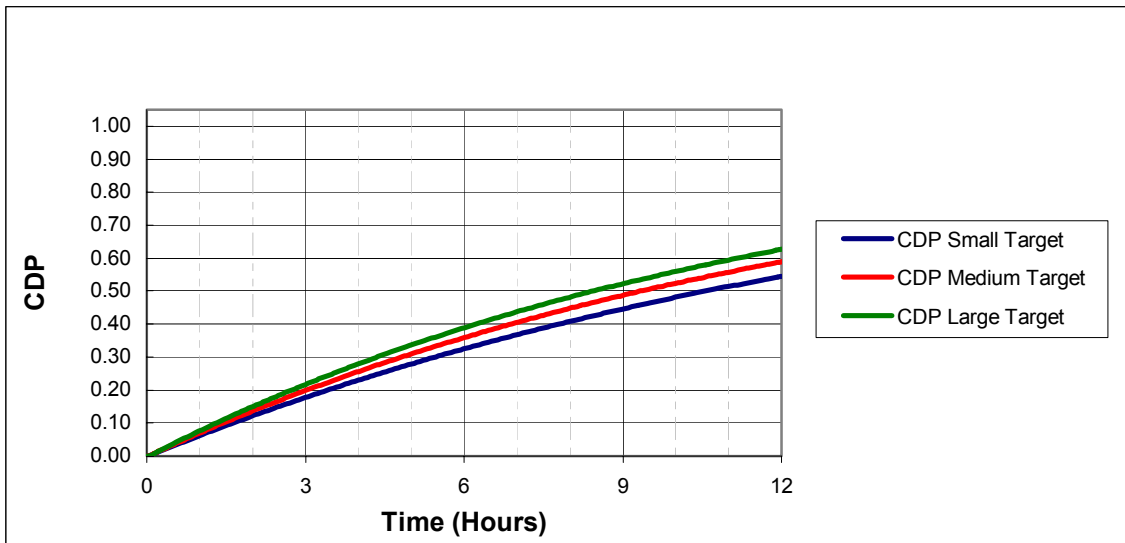

Figure 36. Three-Hour Exposure at Sea State Rough

The resulting plots of CDP as a function of hours of search are between .3 and .4 at one sortie time (6.15 hours). At that point, the CDP is reduced by .12 with respect to the previous case. With three hours periscope exposure time, a search mission is significantly affected by the weather conditions.

In a situation where CDP is degraded due to weather, alternatives already examined with the model are suggested to compensate for the degradation. For example, reducing search area, adding additional aircraft to search simultaneously, or adding more sequential sorties.

This last case of weather degraded CDP may be pessimistic because the original periscope target sizes, i.e. height of exposed periscopes, were held constant in this analysis. A submarine attempting to recharge batteries may need to raise periscopes higher to compensate for greater wave height.

Observing this situation, the analysis is not applied to those sea states beyond sea state 4 because they are extremely affected by those conditions.

4. Twelve-Hour Exposure at Sea State Smooth

This situation is a relationship where the periscope is assumed to be exposed above the sea surface for 12 hours. The RCS of the targets is affected by 10%. The application of the correction factor represents 90% of the RCS. Figure 37 shows the resulting CDP for this situation.

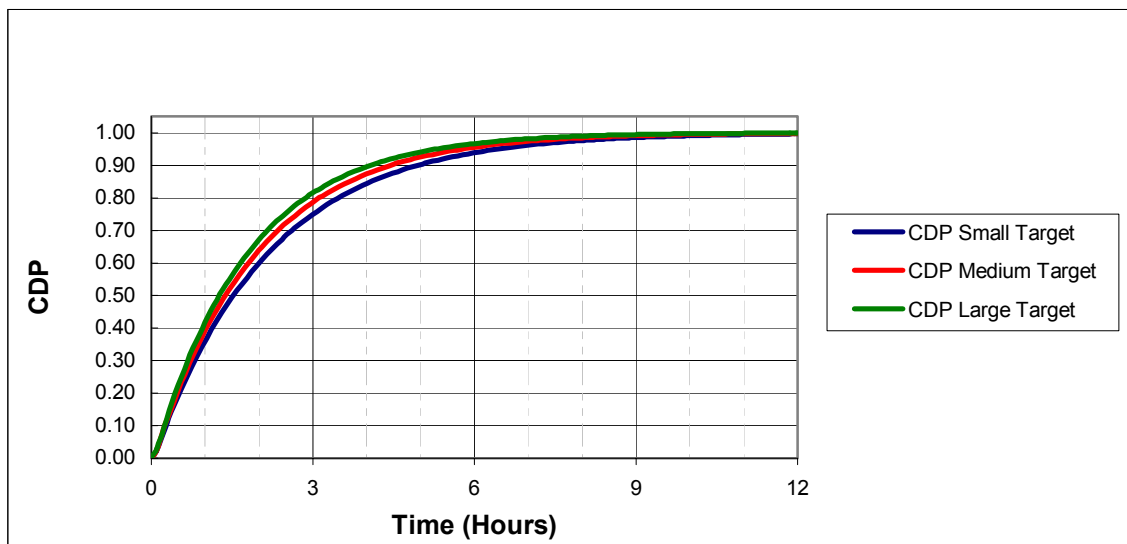

Figure 37. Twelve-Hour Exposure at Sea State Smooth

With this application of the sea state 1 correction, the resulting CDP for a single sortie time is reduced approximately .01 compared with the sea state zero case, which was shown in Figure 33. This is roughly the same degradation as the comparable three hour exposure cases.

5. Twelve-Hour Exposure at Sea State Moderate

This situation shows a relationship keeping the same time used previously and sea state 3. In this case, the RCS of each target is reduced by 50%. Figure 38 shows the resulting CDP for this situation.

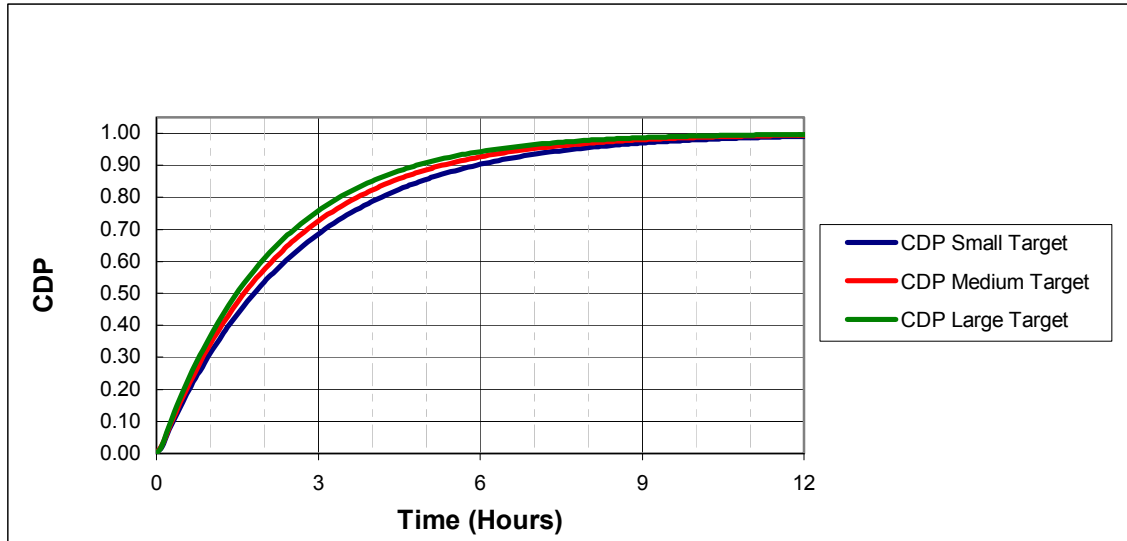

Figure 38. Twelve-Hour Exposure at Sea State Moderate

In this situation, the results are little affected. The variation in the resulting plots of CDP is approximately .04 compared with Figure 33. The weather condition affects the mission but it is possible to execute it because the CDP with respect to one sortie time (6.15 hours) is better than .9.

6. Twelve-Hour Exposure at Sea State Rough

As expressed before, this situation applies the sea state 4 correction reducing RCS to 15% of the value in sea state zero. This reduction is due to the waves being higher than the submarine periscope. Figure 39 shows the results for this combination.

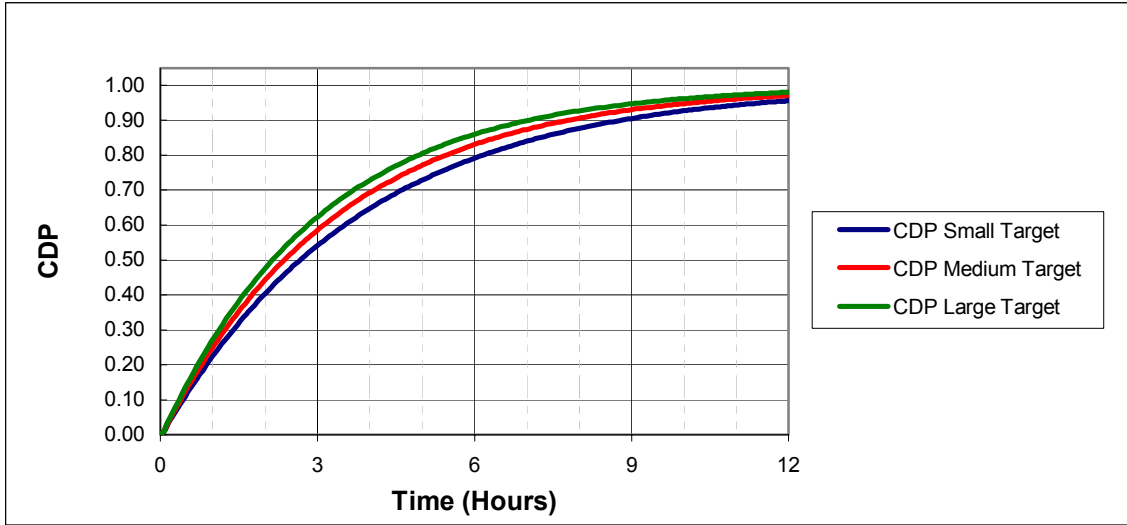

Figure 39. Twelve Hours Periscope Exposed at Sea State Rough

Although there is appreciable degradation compared to sea state zero, with twelve hours of periscope exposure time, CDP for all three target sizes after one sortie time (6.15 hours) of search are still better than .8. This probability is very good for this kind of mission.

7. Twelve-Hour Exposure at Sea State Very Rough

This situation applies corrections for sea state 5, reducing RCS to 2.5% of the RCS in sea state zero. Figure 40 shows the results for this combination.

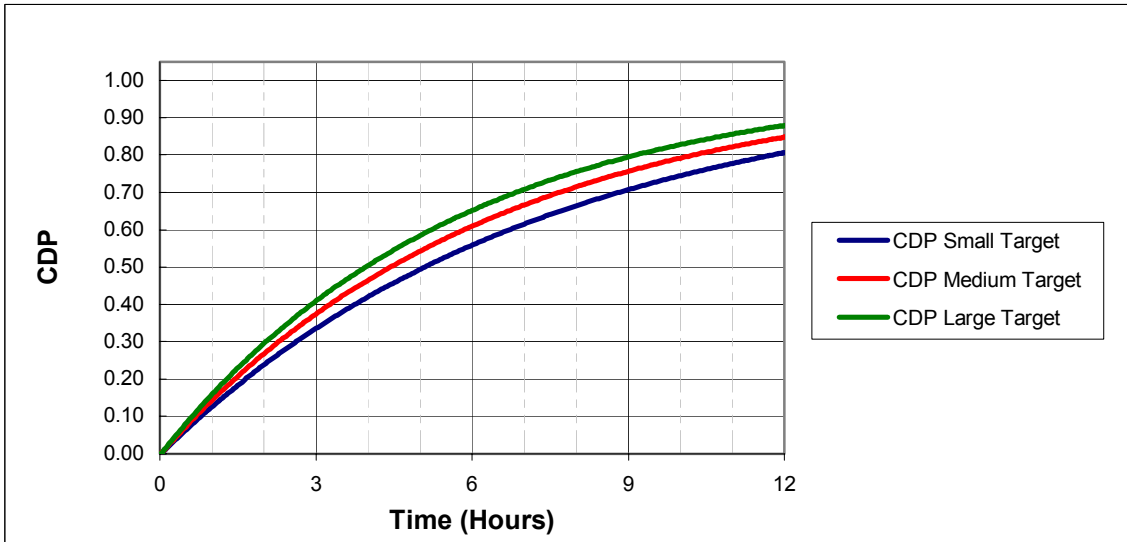

Figure 40. Twelve-Hour Exposure at Sea State Very Rough

Although the cumulative detection probability curves are affected by the weather conditions, the CDP exceeds .5 in one sortie time. Even in very rough sea states, 12 hour exposure time keeps CDP moderately high.

D. COUNTER DETECTION CAPABILITY

This part of the analysis is to observe the variation that could be obtained if the target had this kind of capability. Some situations previously applied in Section C in this chapter are implemented to compare them.

1. Three-Hours Exposure at Sea State Smooth

This situation assumes using three hours periscope exposure above the sea surface and that the sea state is smooth. The submarine could detect the aircraft to determine when it should submerge to avoid detection. This action reduces the CDP. Figure 41 illustrates the results for this situation.

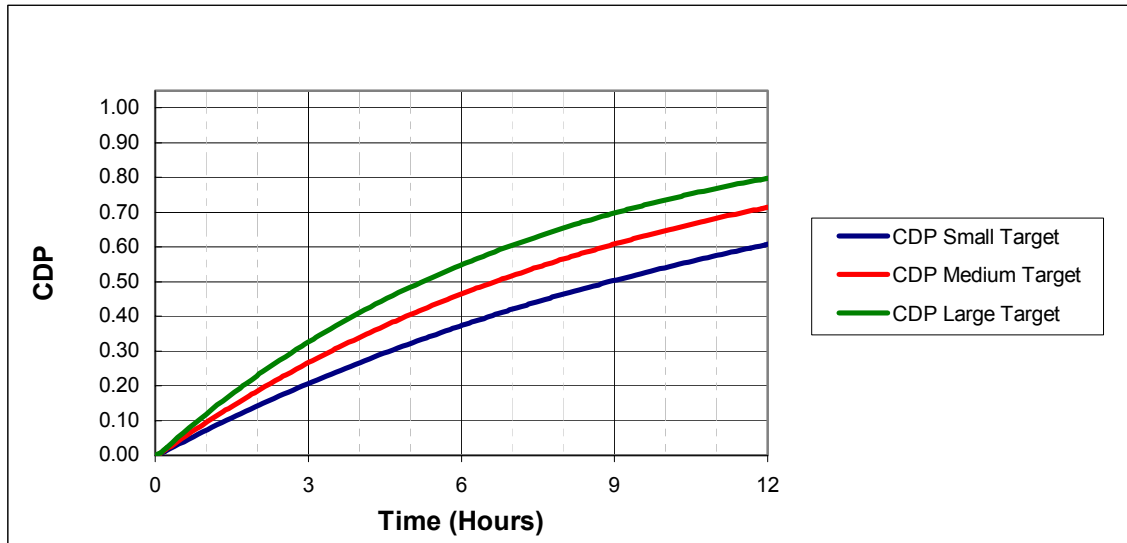

Figure 41. Counter-Detection Capability and Three-Hour Exposure at Sea State Smooth

Comparing these results with those shown in Figure 34, they are significantly affected by this submarine capability. The medium target CDP at one sortie time (6.15 hours) is .47 with counter-detection versus .55 without counter detection capability. In this case, the probability is reduced by approximately .08.

2. Three-Hour Exposure at Sea State Moderate

This situation assumes using the same three hours periscope exposure above the sea surface and that the sea state is moderate. The submarine is assumed to have counter-detection capability. Figure 44 shows the resulting CDP for this situation.

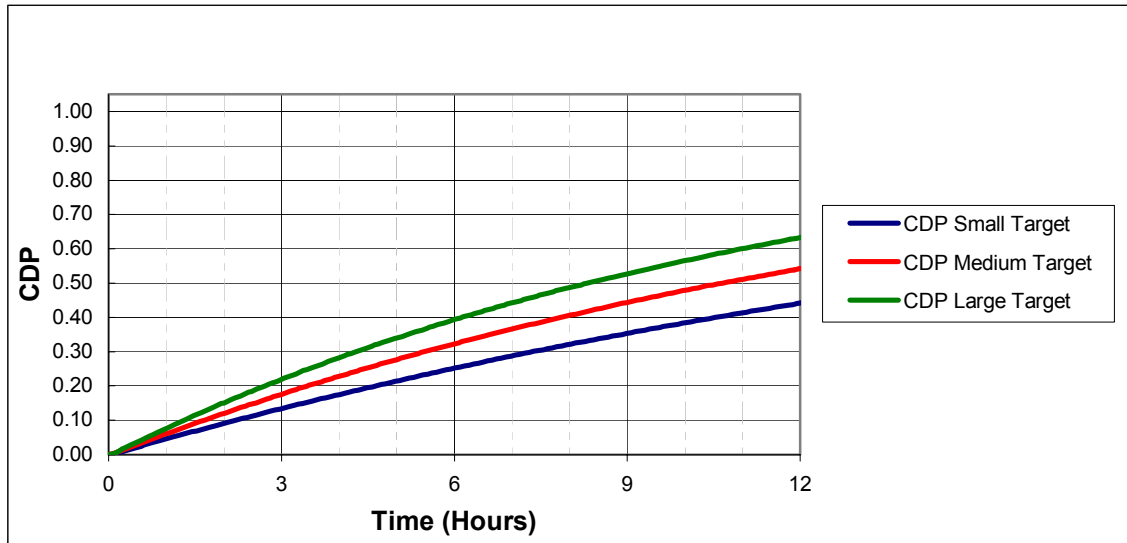

Figure 42. Counter-Detection Capability and Three-Hour Exposure at Sea State Moderate

In this case, the resulting plots, when compared with those shown in Figure 35, demonstrate that they are also affected by this submarine capability. The medium target CDP for one sortie time (6.15 hours) is .33 with counter-detection versus .49 without this capability. In this case, it is approximately reduced by .16, which is twice the reduction in probability from sea state smooth. The effect of RCS reduction creates a compound penalty when the submarine has counter-detection capability. Reduced RCS shortens the maximum effective detection range of radar. This causes two separate factors in the detection rate to diminish. First, the size of the radar patch is reduced, which by itself diminishes the detection rate. Secondly, the shortened radius of the maximum detection area increases the chance that the submarine can avoid detection entirely due to counter-detection evasion, which causes detection rate to diminish further. Both of these factors are approximately proportional to the

square of the maximum detection range. Accordingly, the detection rate is approximately proportional to the fourth power of the maximum detection range. If a diminished RCS decreases maximum detection range by 10% (i.e. to 90% of the previous maximum detection range) then the detection rate is reduced to roughly $(.9)^4$ or approximately $2/3^{\text{rds}}$ of the previous detection rate.

3. Three-Hour Exposure at Sea State Rough

This situation assumes using the same three hours periscope exposure above the sea surface and that the sea state is rough. The submarine is assumed to have counter-detection capability. Figure 43 illustrates the results for this situation.

In this case, the variation in CDP is highly affected by the submarine capability. Comparing the CDP of .14 for a medium target with counter-detection capability to the results in Figure 37, which show a CDP of .37 for a medium target without this capability, the difference is .23. In other words, the RCS reduction due to sea state accentuates the reduction in CDP due to counter-detection.

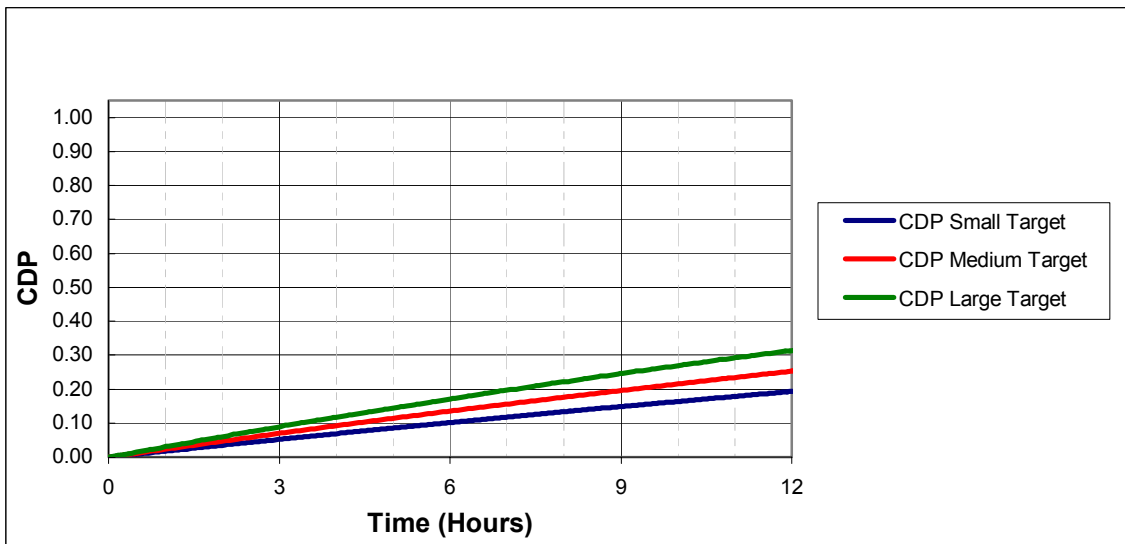

Figure 43. Counter-Detection Capability and Three-Hour Exposure at Sea State Rough

4. Twelve-Hour Exposure at Sea State Smooth

This situation assumes twelve hours periscope exposure time and sea state is smooth. The submarine is also assumed to have counter-detection capability. Figure 44 illustrates the results for this situation.

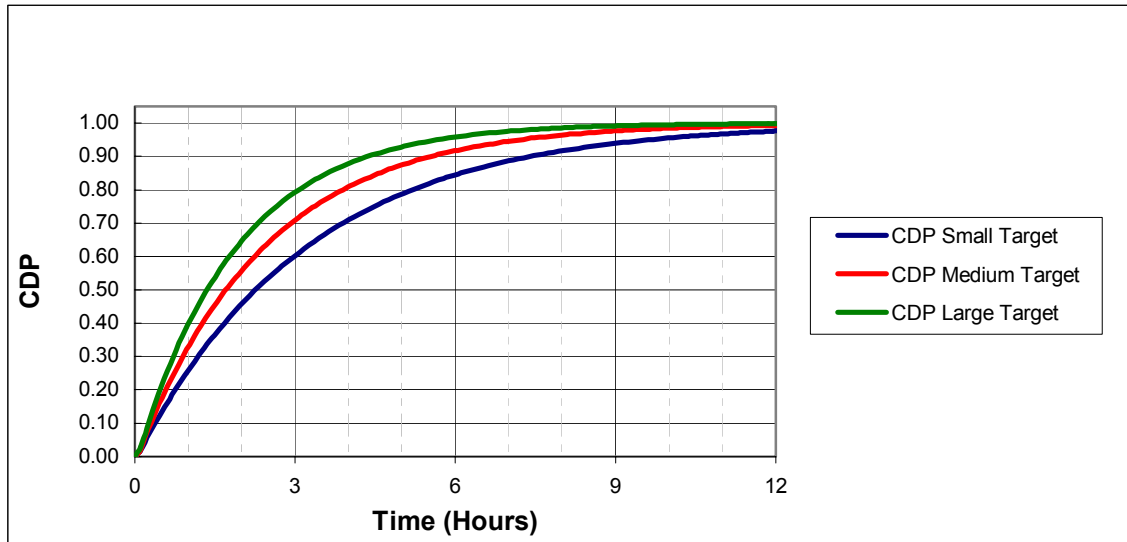

Figure 44. Counter-Detection Capability and Twelve-Hour Exposure at Sea State Smooth

In this case, the degradation is most noticeable in the CDP for small target size. The degradation in probability is approximately .10.

5. Twelve-Hour Exposure at Sea State Rough

This situation assumes using the same twelve hours periscope exposure time and that the sea state is rough. The submarine is also assumed to have the counter-detection capability. Figure 45 illustrates the results for this situation.

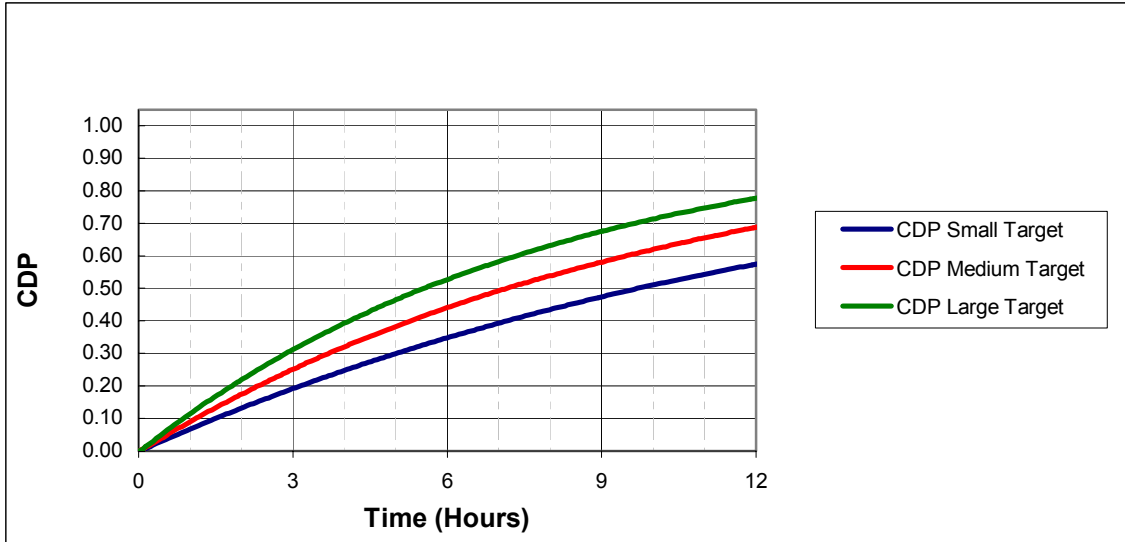

Figure 45. Counter-Detection Capability and Twelve-Hour Exposure at Sea State Rough

In this situation, the variation is notably reduced comparing it with Figure 39. At one sortie time (6.15 hours), the CDP for a medium target in that figure is .84 while in this figure it is .45. The difference is .39. In this case, the detection is significantly affected by the weather conditions and the submarine capability.

THIS PAGE INTENTIONALLY LEFT BLANK

VI. CONCLUSIONS AND RECOMMENDATIONS

A. GENERAL

The CASA 212 S43 aircraft has been operated by Venezuelan Naval Aviation for many years. During the last scheduled maintenance, the CASA 212 S43 aircraft had the RDR 1500B search radar installed. In this thesis, a detection rate model was developed in Microsoft Excel to evaluate the effectiveness of this radar. The development was based on available radar information and different operational assumptions, which were very similar to real situations, although the assumptions have not been proven in a real operational situation. In other words, Venezuela has never encountered this type of situation.

This evaluation was completed assuming a situation in which the aircraft is operated in an anti-submarine warfare (ASW) mode. Three types of target sizes were modeled to compare results. The target represents a diesel submarine periscope, which is intermittently exposed above the sea surface.

An ASW mission is one type of mission that could be conducted with this aircraft. Normally, this type of mission is executed together with the Venezuelan Navy surface vessels.

Several conclusions were drawn after building the detection rate model and analyzing the RDR 1500B search radar installed in the CASA 212 S43 aircraft.

B. CONCLUSIONS

Throughout this research, some significant operational findings were identified concerning such factors as the search area size, the number of aircraft used, the submarine periscope exposure time, the submarine counter-detection capability, and the weather conditions present in the search area.

To analyze search effectiveness, cumulative detection probability versus the search time was used as the measure of effectiveness. For the CASA 212

S43 aircraft a critical period of search is a single sortie time of 6.15 hours, which represents the maximum flight time that the aircraft may be operated in one mission. The model was exercised, starting with the entire Venezuelan Caribbean Sea area and successively halving the search area until cumulative detection probability for a single sortie was seen to be .5 or better. It was found that a search area size of 3900 nm² could result in such a CDP. This is the area of, for example, a 60 nm by 65 nm rectangle, which is a reasonable size for an area search patrol by a CASA 212 S43.

The conclusion about a search area size of 3,900 nm² was derived with a model input of three hours of submarine periscope exposure per 24 hour operational period. The analytical model shows that detection rate is directly proportional to periscope exposure hours, i.e., if periscope exposure time is doubled the detection rate is doubled. Detection rate is also inversely proportional to the search area. Accordingly, if it is determined that the submarine periscope exposure time is increased by any percentage, the aircraft search area can also be increased by the same percentage and still achieve the same CDP.

Multiple aircraft or multiple sorties can be employed in two ways to achieve two different results. One method would be to assign sequential sorties to the same search area, which would increase CDP as a function of the total hours of search effort in that area. Alternatively, additional aircraft could be assigned to other search boxes for one sortie each, which would result in the same CDP but over the larger total area searched. Of course, combinations could be used.

When the radar horizon from the airborne radar is a longer distance than the maximum detection range, the difference between these two areas represents an area within which the submarine can detect the radar emission, but the airborne radar cannot see the much smaller radar reflection. This affords the submarine a chance to submerge and avoid being caught with exposed periscopes. Fortunately, for the RDR 1500B, low altitude both increases the

maximum detection range, and shortens the distance to the radar horizon, and thus minimizes the probability that a submarine can take advantage of a counter-detection capability. However, the CASA 212 S43 aircraft, like most aircraft, does not get best fuel endurance at low altitude. Therefore, there is a tradeoff of flight endurance for detection probability.

For a fixed periscope exposure height, increasing sea-state has the effect of decreasing target RCS. The effect of RCS reduction creates a compound penalty when the submarine has counter-detection capability. Reduced RCS shortens the maximum effective detection range of radar. This causes two separate factors in the detection rate to diminish. First, the size of the radar patch is reduced, which by itself diminishes the detection rate. Secondly, the shortened radius of the maximum detection area increases the chance that the submarine can avoid detection entirely due to counter-detection evasion, which causes detection rate to diminish further. Both of these factors are approximately proportional to the square of the maximum detection range. Accordingly, the detection rate is approximately proportional to the fourth power of the maximum detection range. If diminished RCS decreases maximum detection range by 10% (i.e. to 90% of the previous maximum detection range) then the detection rate is reduced to roughly $(.9)^4$ or approximately $2/3^{\text{rds}}$ of the previous detection rate. The operational implication of this is that as sea-state increases, the aircraft search plan may need to compensate for the reduced RCS with much smaller search areas and lower search altitudes.

To make tactical decisions, this analytical model would help the Venezuelan Navy Operations Chairman because of its versatility in changing target RCS, which affects the maximum range, flight altitude and flight time, for example. Also, this analysis and the model could help determine what actions the Venezuelan Navy Chairman should take concerning the search area size, the number of aircraft and operational characteristics, and target characteristics because the model gives results when varying those parameters.

Another conclusion is that the Venezuelan Navy Intelligence Division should be able to give geographical location information about any enemy operation in Venezuelan territorial waters to help narrow down the search to search area sizes smaller than the total Venezuelan Caribbean Sea. If this division does not develop the information about enemy submarines, then Venezuelan Navy operating forces will need more resources to implement sufficient search presence in the larger search area.

C. RECOMMENDATIONS

The results obtained from the analytical model developed in this thesis were compared with a simulation model being developed by another student. The results were very similar. However, further validation of this model is desirable, preferably with real-world data. The best method is operational testing and evaluation by implementing situations in which the CASA 212 S43 aircraft is searching for a diesel submarine periscope, varying operational parameters as done in the analysis. This collected data would then be used for comparison with the theoretical results of this model. .

The RDR 1500B search radar should be exercised in ASW missions to determine operationally what its effectiveness could be. In other words, it is recommended to obtain data by real operational situations with the purpose of analyzing this and making better conclusions; which would help in future systems acquisition.

Strategically, Venezuela is divided into patrol areas in which the search area size is a constraint. This model could be used to help quantitatively analyze the effects of varying the size of patrol areas.

APPENDIX

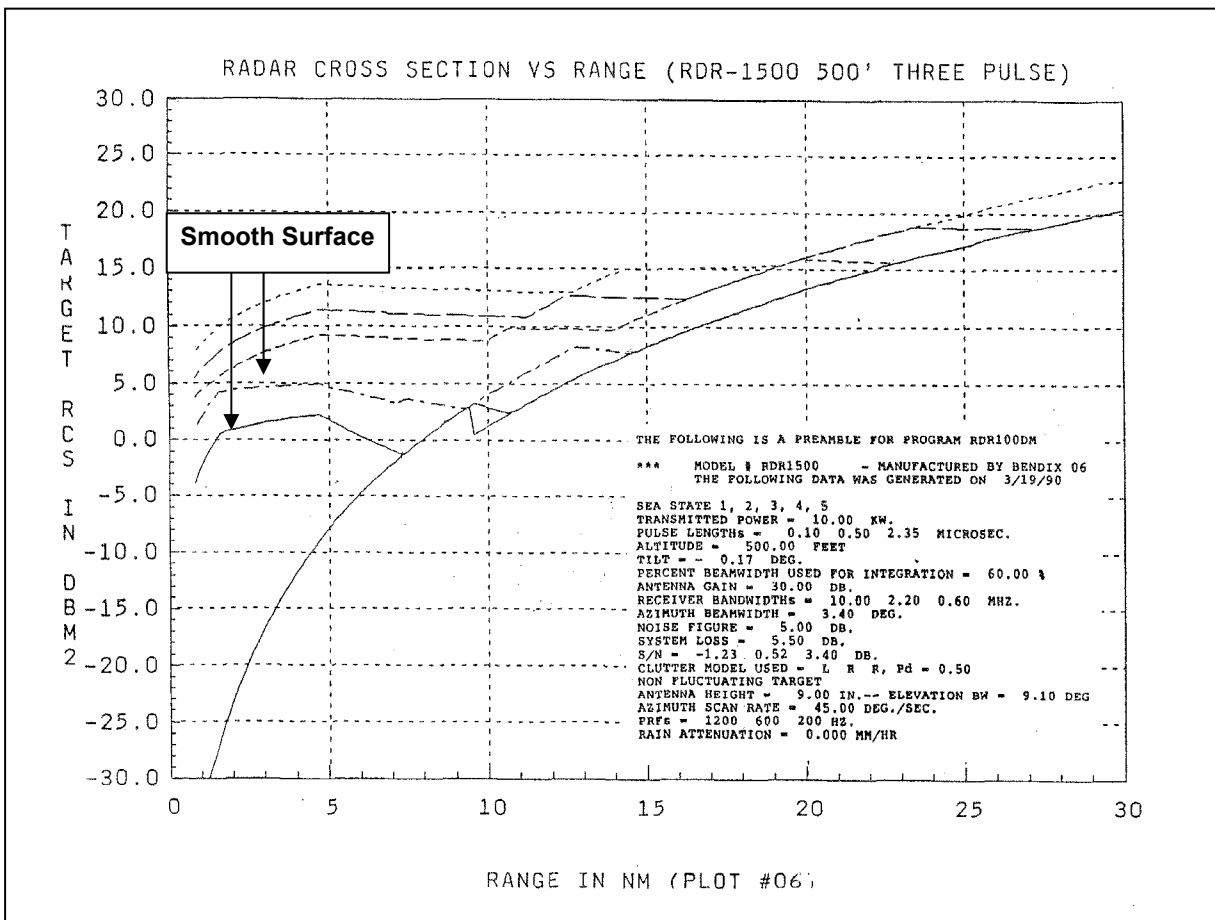

Figure 46. RCS vs. Ranges at 500 Feet

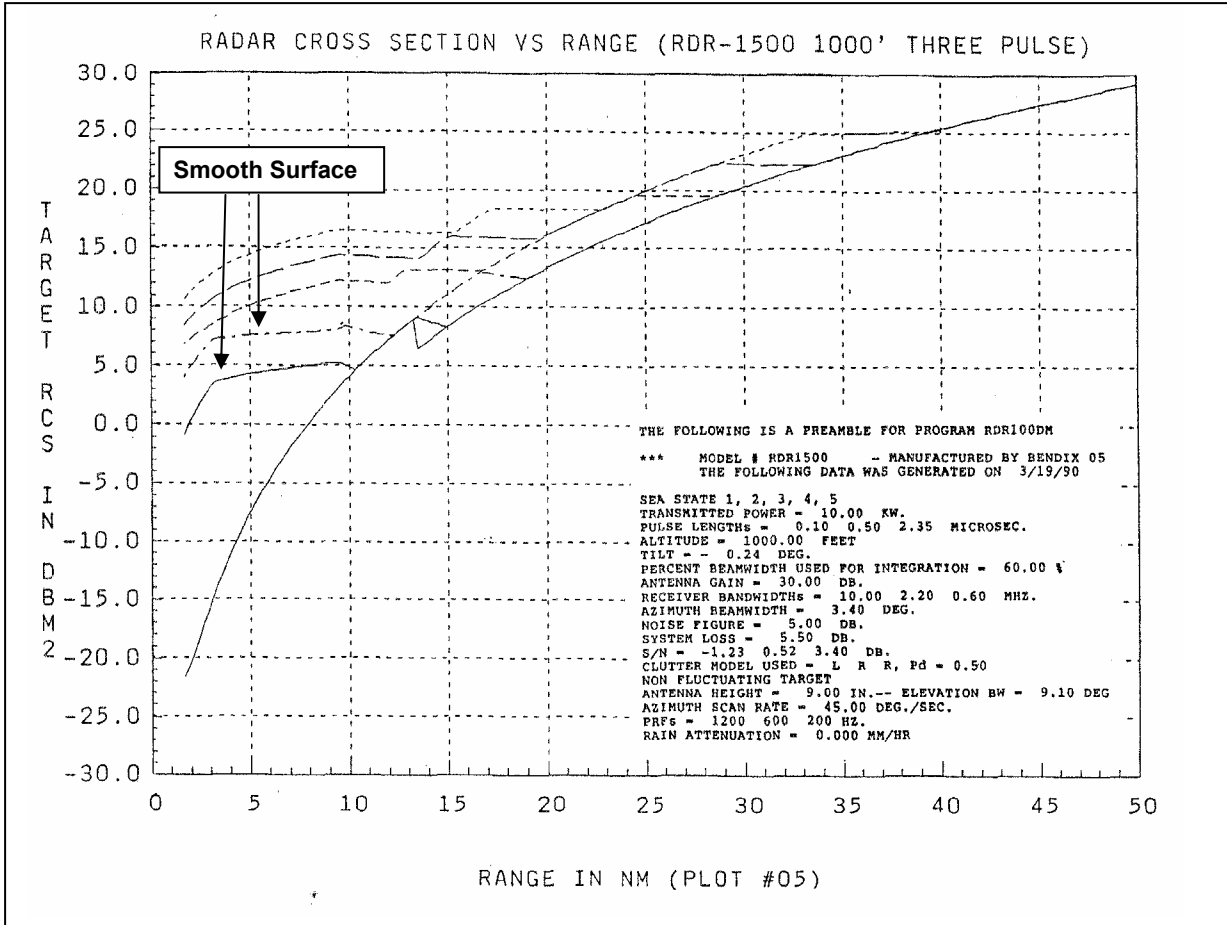

Figure 47. RCS vs. Ranges at 1000 Feet

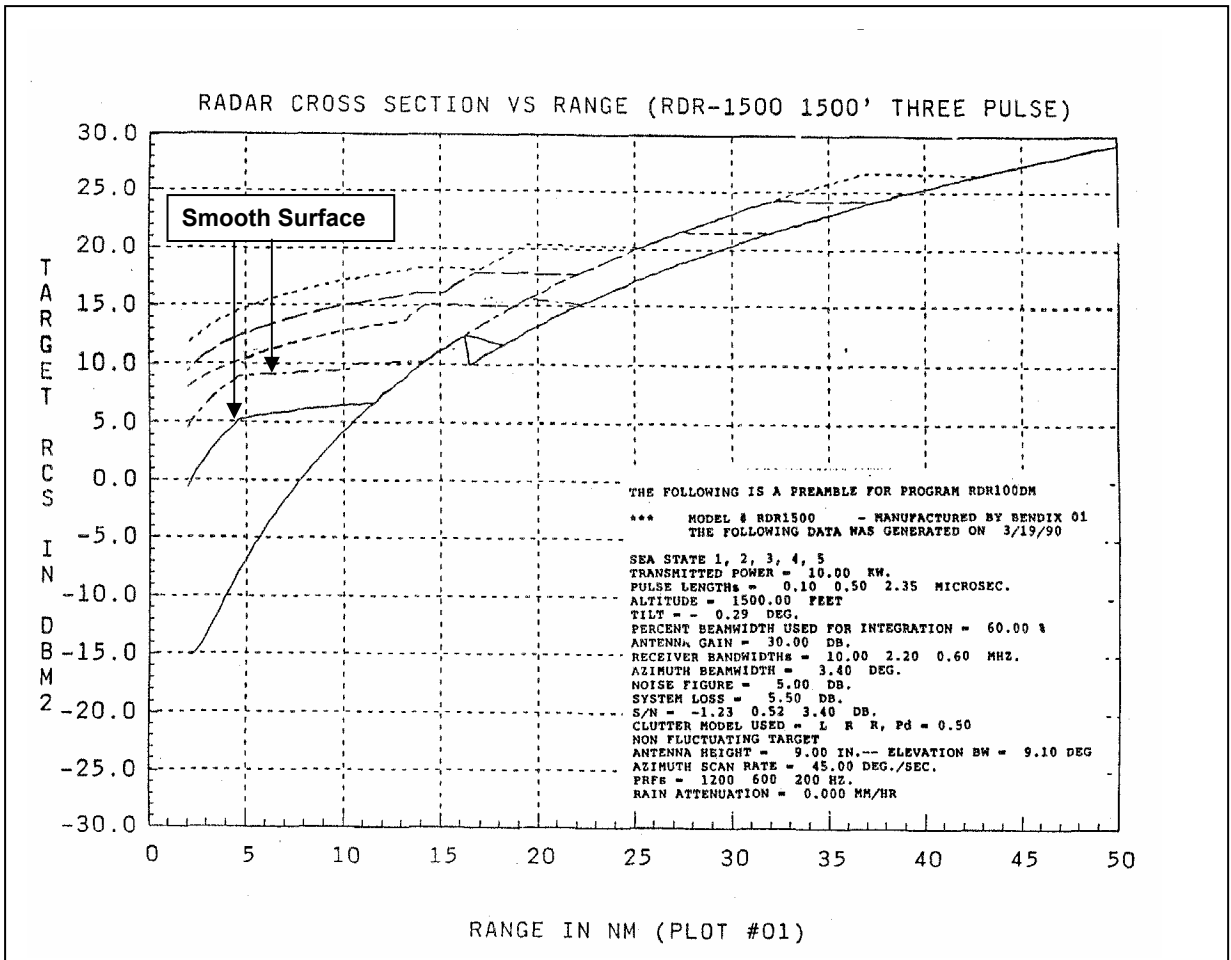

Figure 48. RCS vs. Ranges at 1500 Feet

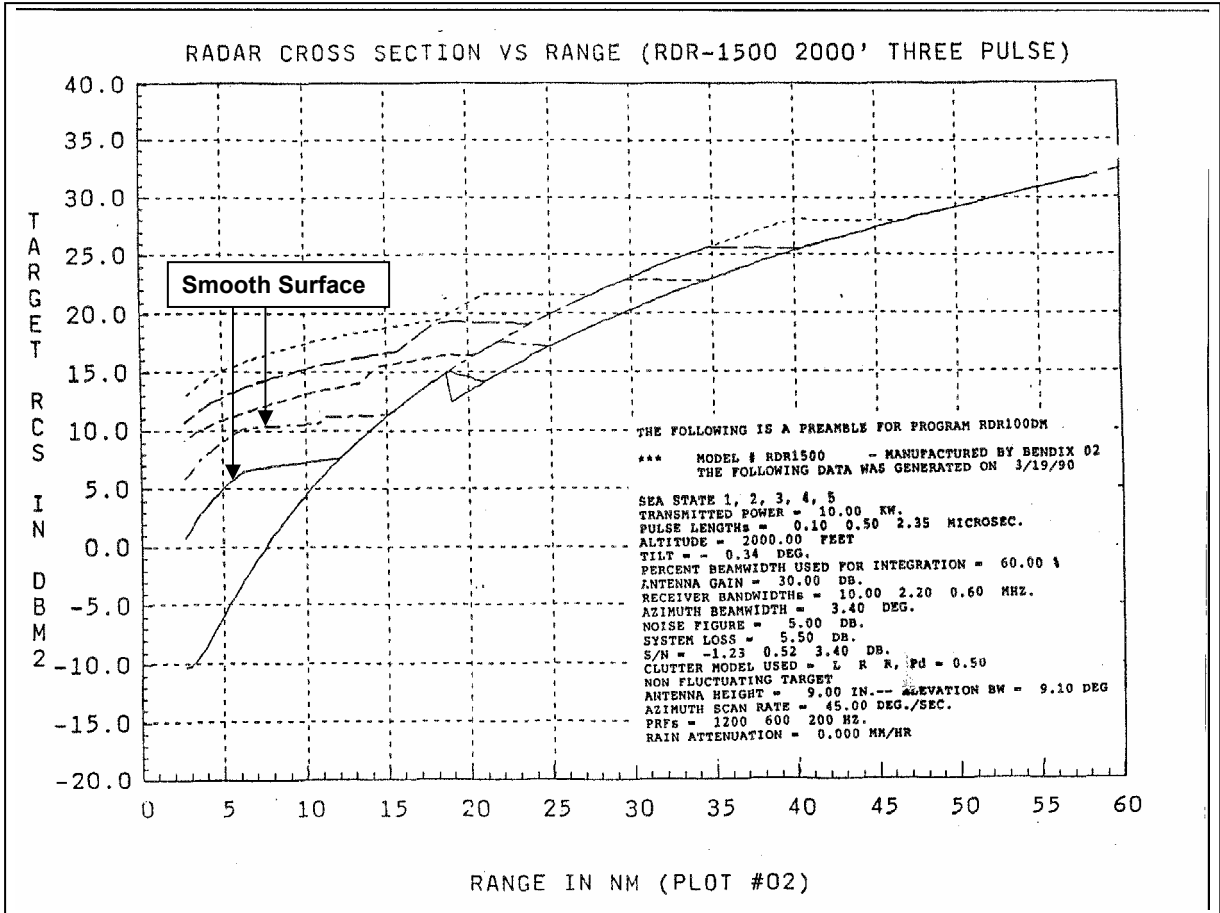

Figure 49. RCS vs. Ranges at 2000 Feet

LIST OF REFERENCES

1. Wagner, Daniel H., Mylander C. and Sanders, Thomas J., Naval Operations Analysis, Naval Institute Press, 1999.
2. www.telephonics.com/products/1500.shtml. Telephonics Corporation, Products and Services, RDR-1500B Color Weather Search and Rescue Radar. A Griffon Company, 2004, Accessed April 2004.
3. AlliedSignal AEROSPACE Commercial Avionics System RDR-1500B 360° Search and Surveillance Radar System Operator's Manual, 1980.
4. Maintenance Manual RDR-1500B Radar System Part 1, Construcciones Aeronautica S.A (CASA) Company, March 1997.
5. Skolnik, Merrill Ivan, Introduction to Radar System, McGraw-Hill, 2001.
6. Stimson, George W., Introduction to Airborne Radar, Scitech Publishing. Inc., 1998.
7. Gaver, Donald, P., Jacobs, Patricia A. and Stoneman, J., Analytical Models for Mobile Sensor (UAV) Coverage of a Region, Operations Research Department, Naval Postgraduate School, 1999.
8. Manual de Doctrina de Empleo del Comando de la Aviación Naval (MAN-DC-CNAOP-0004). Comando Naval de Operaciones, Venezuelan Navy. 2001.
9. Observatorio Naval Cajigal, Aguas Marinas y Submarinas de Venezuela. Comando Naval de Operaciones Venezuelan Navy, February 1985.
10. Washburn, Alan R., Search and Detection, Military Applications Section Operations Research Society of America c/o Ketron, 1981.
11. <https://ewhdbks.mugu.navy.mil/rcs.htm>. Allen E. Fuhs, Radar Cross Section (RCS), 1984, Accessed September 2004.
12. Knott, Eugene F., Radar Cross Section Measurements, Van Nostrand Reinhold, NY, 1993.
13. Mahafza, Bassem R., Radar Systems Analysis and Design Using Matlab, Chapman & Hall/CRC, 2000.
14. Pilnick, Steven E., Class Notes for OA3602, Search and Detection Theory Operations Research Department, Naval Postgraduate School, 2004.

15. CASA, Flight Manual to Operators CASA 212 S43 Aircraft, Spain, October 1987.
16. Bowditch, Nathaniel, LL.D., Basics of Weather Observations, an Epitome of Navigation, National Imagery and Mapping Agency, 1995.
17. Ross, Sheldon M., Introduction to Probability Models, University of California at Berkeley, Eighth Edition, 2003.

INITIAL DISTRIBUTION LIST

1. Defense Technical Information Center
Ft. Belvoir, Virginia
2. Dudley Knox Library
Naval Postgraduate School
Monterey, California
3. Naval Aviation Command
Naval Operations Command
Venezuelan Navy
Volmert Avenue, San Bernardino
Caracas, Dtto Federal
Venezuela
4. Naval Education Command
Venezuelan Navy Command
Volmert Avenue, San Bernardino
Caracas, Dtto Federal
Venezuela
5. Professor Steven E. Pilnick
Operations Research Department
Naval Postgraduate School
Monterey, California
6. Professor Matthew G. Boensel
Systems Engineering Department
Naval Postgraduate School
Monterey, California