

REPORT DOCUMENTATION PAGE

Form Approved
OMB No. 0704-0188

Public reporting burden for this collection of information is estimated to average 1 hour per response, including the time for reviewing instructions, searching existing data sources, gathering and maintaining the data needed, and completing and reviewing the collection of information. Send comments regarding this burden estimate or any other aspect of this collection of information, including suggestions for reducing this burden, to Washington Headquarters Services, Directorate for Information Operations and Reports, 1215 Jefferson Davis Highway, Suite 1204, Arlington, VA 22202-4302, and to the Office of Management and Budget, Paperwork Reduction Project (0704-0188), Washington, DC 20503.

1. AGENCY USE ONLY (Leave blank)	2. REPORT DATE January 2005	3. REPORT TYPE AND DATES COVERED USARIEM Technical Note	
4. TITLE AND SUBTITLE Physiological Data Acquisition System Documentation		5. FUNDING NUMBERS	
6. AUTHOR(S) S.B. Robinson, L. Elliott		8. PERFORMING ORGANIZATION REPORT NUMBER TN05-03	
7. PERFORMING ORGANIZATION NAME(S) AND ADDRESS(ES) Thermal & Mountain Medicine Division U.S. Army Research Institute of Environmental Medicine Kansas Street Natick, MA 01760-5007		10. SPONSORING / MONITORING AGENCY REPORT NUMBER	
9. SPONSORING / MONITORING AGENCY NAME(S) AND ADDRESS(ES) Same as #7 Above		11. SUPPLEMENTARY NOTES	
12a. DISTRIBUTION / AVAILABILITY STATEMENT Approved for public release; distribution is unlimited.		12b. DISTRIBUTION CODE	
<p>13. ABSTRACT (Maximum 200 words)</p> <p>This report describes a data acquisition system developed to obtain electrocardiogram (ECG), pulse waveform, core and skin temperature measurements, as well as ambient climactic conditions. These data are typical of those collected during heat-strain studies in climatic chambers in USARIEM. Since acceptable commercial systems are not available, this system was custom-built to acquire data using National Instruments hardware components and LabVIEW 7.0 Express Developmental Software.</p> <p>General requirements for this system are that it be highly accurate, precise, and expandable for future studies. The system also needs to function within the environmental temperatures of the protocol.</p> <p>Data collection for this system is achieved by sampling analog and digital signals at regular intervals from thermocouples, thermistors, outboard data collection devices, user input controls, and modifying them within the custom software to obtain real-time measurements.</p> <p>The software Graphical User Interface (GUI) is designed to be user-friendly, with minimal user input configurations to manage. The interface is also designed to provide both a graphical history of data, as well as a numerical history in tabular form.</p> <p>Finally, data are secured by opening the destination file, appending data to this file, and closing this file each time data are collected. This method ensures that data are not lost during power failure or if the LabVIEW software is corrupted.</p>			
14. SUBJECT TERMS Data acquisition, ECG, heart rate, Finapres, Nellcor, blood pressure, LabVIEW, core temperature, skin temperature, pulse oximetry		15. NUMBER OF PAGES 26	
17. SECURITY CLASSIFICATION OF REPORT Unclassified		16. PRICE CODE	
18. SECURITY CLASSIFICATION OF THIS PAGE Unclassified	19. SECURITY CLASSIFICATION OF ABSTRACT Unclassified	20. LIMITATION OF ABSTRACT Unclassified	

USARIEM TECHNICAL NOTE TN05-03

PHYSIOLOGICAL DATA ACQUISITION SYSTEM DOCUMENTATION

Scott B. Robinson
Leonard Elliott

Thermal and Mountain Medicine Division

January 2005

U.S. Army Research Institute of Environmental Medicine
Natick, MA 01760-5007

DISCLAIMERS

Approved for public release; distribution is unlimited.

The views, opinions and/or findings contained in this publication are those of the authors and should not be construed as an official department of the army position, policy or decision unless so designated by other documentation.

The investigators have adhered to the policies for protection of human subjects as prescribe din Army Regulation 70-25, and the research was conducted in adherence with the provisions of 45 CFR part 46.

TABLE OF CONTENTS

<u>SECTION</u>	<u>PAGE</u>
LIST OF FIGURES.....	iv
LIST OF TABLES.....	iv
SYMBOLS/ACRONYMS/ABBREVIATIONS.....	v
INTRODUCTION.....	1
MATERIALS.....	2
METHODS.....	2
Measurements.....	2
User Interface Design.....	2
Programming Design.....	2
Physical Connections/Wiring.....	4
Data Security/Validation.....	4
FIGURES/TABLES.....	5
DIAGRAMS.....	11
COMPONENT SPECIFICATIONS.....	14
SCXI-1000.....	14
SCXI -1102.....	16
SCXI -1300.....	18
STANDARD OPERATING PROCEDURE FOR PHYSIOLOGICAL DATA ACQUISITION SYSTEM (SCXI).....	19
REFERENCES.....	20

LIST OF FIGURES

<u>FIGURE</u>		<u>PAGE</u>
1	Graphical User Interface.....	5
2	Write to Spreadsheet.vi	5
3	ECG Acquisition Loop	6
4	MWST_4site.vi	6
5	Date_time.vi	7
6	Temp_Header.vi	7
7	ECG_Header.vi	8
8	Waves_Header.vi.....	8

LIST OF TABLES

<u>TABLE</u>		<u>PAGE</u>
1	Spreadsheet labeling scheme.....	9
2	Terminal block wiring scheme	10

SYMBOLS/ACRONYMS/ABBREVIATIONS

Ω	Ohms (resistance)
$^{\circ}\text{C}$	Degrees Celcius
μA	Microamps
μV	Microvolts
A	Amps
AC	Alternating current
A/D	Analog to digital
Acq. AI	Acquire Analog Input
ASCII	American Standard Code for Information Interchange
CPU	Central processing unit
D/A	Digital to analog
DAQ	Data Acquisition
DC	Direct Current
DMM	Digital Multimeter
ET	Elapsed Time
*.exe	Executable file (PC-compatible application)
GUI	Graphical user interface
mA	Milliamps
ms	Milliseconds
mV	Millivolts
MAX	Measurement and Automation Explorer
NI	National Instruments
SCXI	Signal Conditioning extensions for Instrumentation
SOP	Standard operating procedure

T_a	Ambient temperature
TBX	Terminal block
V	Volts or voltage
VI	Virtual Instrument

INTRODUCTION

This report describes a data acquisition system developed to obtain electrocardiogram (ECG), pulse waveform, core and skin temperature measurements, as well as ambient climactic conditions. These data are typical of those collected during heat-strain studies in climatic chambers in USARIEM. Since acceptable commercial systems are not available, this system was custom-built to acquire data using National Instruments hardware components and LabVIEW 7.0 Express Developmental Software.

General requirements for this system are that it be highly accurate, precise, and expandable for future studies. The system also needs to function within the environmental temperatures of the protocol.

Data collection for this system is achieved by sampling analog and digital signals at regular intervals from thermocouples, thermistors, outboard data collection devices, user input controls, and modifying them within the custom software to obtain real-time measurements.

The software Graphical User Interface (GUI) is designed to be user-friendly, with minimal user input configurations to manage. The interface is also designed to provide both a graphical history of data, as well as a numerical history in tabular form.

Finally, data are secured by opening the destination file, appending data to this file, and closing this file each time data are collected. This method ensures that data are not lost during power failure or if the LabVIEW software is corrupted.

MATERIALS

- (1) NI LabVIEW 7.0 Express Developmental Software Package
- (1) NI SCXI-1000 4-slot chassis
- (1) NI SCXI-1102 analog input module
- (1) NI SCXI-1102c analog input module
- (2) NI SCXI-1300 32-channel terminal blocks
- (1) NI 68-POS series D-type cable assembly (type SHC68-68EP 1m.)
- (1) NI 68-POS cable adaptor for SCXI-1000 chassis
- (1) NI DAQ card-6036E multifunction PCI data acquisition card
- (1) Desktop computer with 1 unused PCI port
- (1) Fluke 27 Digital Multimeter
- (1) HP 34902A 16-Channel Reed Multiplexer
- (1) Agilent 82357A USB/GPIB interface
- (1) Agilent 34970A Data Acquisition/Switch Unit
- (1) Philips Viridia UHF Telemetry System
- (1) Nellcor Pulse-Oximeter
- (1) Ohmeda Finapres Finger Blood Pressure Monitor
- (1) Generic 25-pin 4-port switch box

METHODS

MEASUREMENTS

The system is developed to measure signals from thermocouples, thermistors, and data collection devices using National Instrument's hardware. The data are then processed, manipulated, displayed using National Instrument's LabVIEW data acquisition software.

USER INTERFACE DESIGN

The GUI is designed to meet all of the needs of the investigator and display data (both numerically and graphically) in an intuitive manner (Figure 1). It is also designed to provide the investigator with hands-free data management while remaining aesthetically pleasing.

A log of collected data (in tabular format) is visible, displaying the last eight samples acquired. Previously collected data is still accessible by scrolling downward. The table is modified so that the top-most row of data is the most current; incoming data will append to this table. The table displays the current core, skin, calculated mean weighted skin, ambient and dew point temperatures.

PROGRAMMING DESIGN

In order to keep data flowing smoothly and allow LabVIEW programmers to update/conceptualize the code without difficulty, the program is designed in a systematic and concise manner consistent with standards for programming in a data

flow language. Three different sampling rates for data acquisition were required, therefore three “while loops” were written to allow scanning at each of three intervals. Skin, core, ambient, and dew point temperatures need to be measured at 60 second intervals, ECG needs to be measured at 1000 samples/second, and waveforms from the Finapres finger blood pressure monitor and Nellcor pulse oxymeter need to be measured at 100 samples/second. The main portions of the program are built within these “while loops” and, once initiated, will run continuously until the user clicks the stop button, which is a “stop if true” Boolean. Upon activating this button, the activity within the loop will cease, and data will stop being collected. The program collects data, manipulates them as desired, and writes to disk within this main loop. Outside the loop is a VI (Figures 2, 6, 7, and 8) that opens a file, obtains an initial time and date stamp, acquires a file name according to the users text input string entry entitled filename, writes a series of predetermined “headers” for each spreadsheet column, and then passes this information into the loop that writes these data to the beginning of the spreadsheet. Data collected from this point on append to the end of each row to eliminate the potential for overwriting data.

Several actions occur simultaneously within the main loop of the program. To collect data from each channel, an “AI one pt” VI initializes the hardware, configures it for measurement, measures the voltage, passes voltage waveform data out, and clears the data from each channel for future measurements, in that order (Figure 3). The “Y” value (voltage) is then pulled off the waveform and passed on for collection or further processing (Figure 4). Simultaneously, the Agilent 34970A Data Acquisition/Switch Unit measures resistance from the rectal thermistor and passes data to LabVIEW via a RS-232 communications port.

The data table displayed on the front panel is generated by pulling off the array of data destined for the “Write to Spreadsheet” VI and converting the array of numbers to an array of strings wired to a pre-formatted table. The array is arranged so that the top-most row displays the last measurement collected.

Each group of samples has an associated timestamp to indicate the exact hour, minute, second, and millisecond that the data were acquired. Timestamps are handled by acquiring hours, minutes, seconds, and milliseconds from the CPU clock time and writing them in separate columns of a spreadsheet. A running time is also acquired by taking the absolute value of a “Get Date/Time In Seconds” VI and subtracting the time acquired at zero start time (Figure 5).

The GUI was designed to display real-time data in the form of numerical indicators, 2D graphs, and historical table format. Electrocardiogram, Nellcor pulse waves, and Finapres pulse waves are displayed in real-time, identical to the source which generated the signal. In addition, Nellcor oxygen saturation and Finapres pulse rate are displayed in numerical format.

All temperature-related data collected are displayed on the front panel in table format with the last eight samples collected in continuous view. The table contains vertical and horizontal scrollbars to view the entire data set collected. The spreadsheet column titles are listed in the Table 1. ECG, Nellcor pulse wave and rate, and

Finapress pulse wave and oxygen saturation raw values are not displayed in the table, due to their high sample rates.

PHYSICAL CONNECTIONS/WIRING

This system was developed to perform in chambers 236a (for pre and post test measurement phase) and 236c (for dehydration phase). The data needed to be collected with minimal loss during transition to each chamber, therefore the LabVIEW data acquisition system was hosted by one PC with signals fed in from both chamber simultaneously, selectable by a generic 25-pin 4-port rotary switch box. Voltages were collected on one SCXI-1102 and one SCXI-1102c analog input modules using the SCXI-1300 terminal blocks. The SCXI-1102c is dedicated for high frequency measurements and is set up to measure ECG voltage, Finapress pulse waveform and pulse rate, and Nellcor pulse waveform and oximetry. The SCXI-1102 is dedicated to high resolution/lower frequency measures including air, dew point, and skin thermocouple measurements. Resistances were measured on the Agilent 34970A Data Acquisition/Switch Unit. Table 2 (Terminal Block Wiring Scheme) shows the order of wiring on each of the two terminal blocks. See first diagram for complete schematic of instruments, connections, wiring, and data flow.

DATA SECURITY/VALIDATION

Several measures have been taken, in the design of this system, to ensure the integrity of the data. The system is designed to acquire samples at three different sampling intervals, with the user-option to monitor (without recording) or record/write data in ASCII format to disk (C:\unique_filename.txt) immediately after acquiring the sample. Thus, if the system/equipment were to fail during a test, data will still be recoverable up to the failure point, given the data file has not been corrupted. In addition, the system will time-stamp each sample (HH:MM:SS:MS). Additionally, the subject ID number will also be able to be entered by the user to assist in identifying test results when analyzing data at a later point.

Figure 3. ECG Acquisition Loop

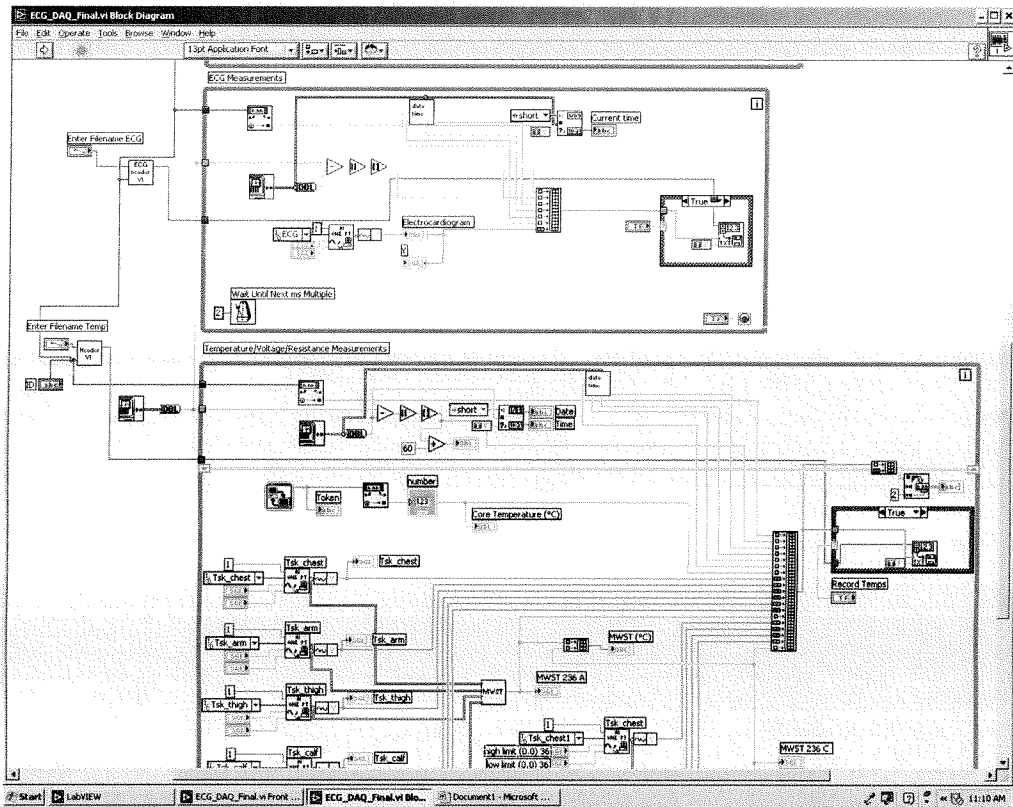

Figure 4. MWST_4site.vi

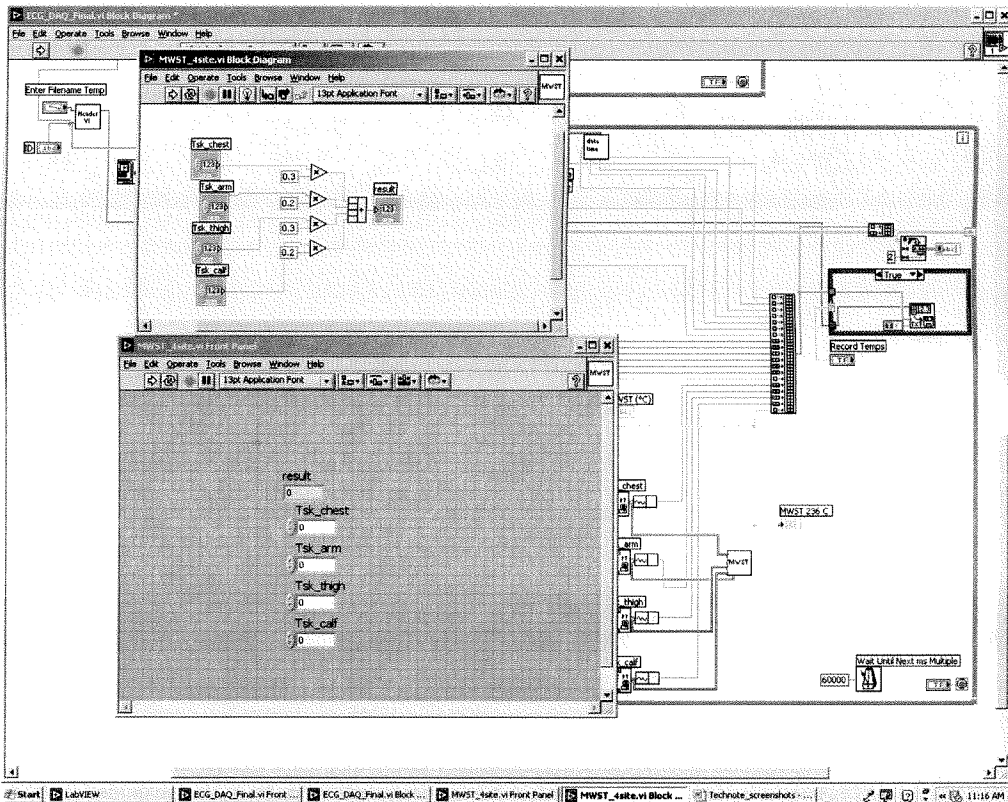

Figure 5. Date_time.vi

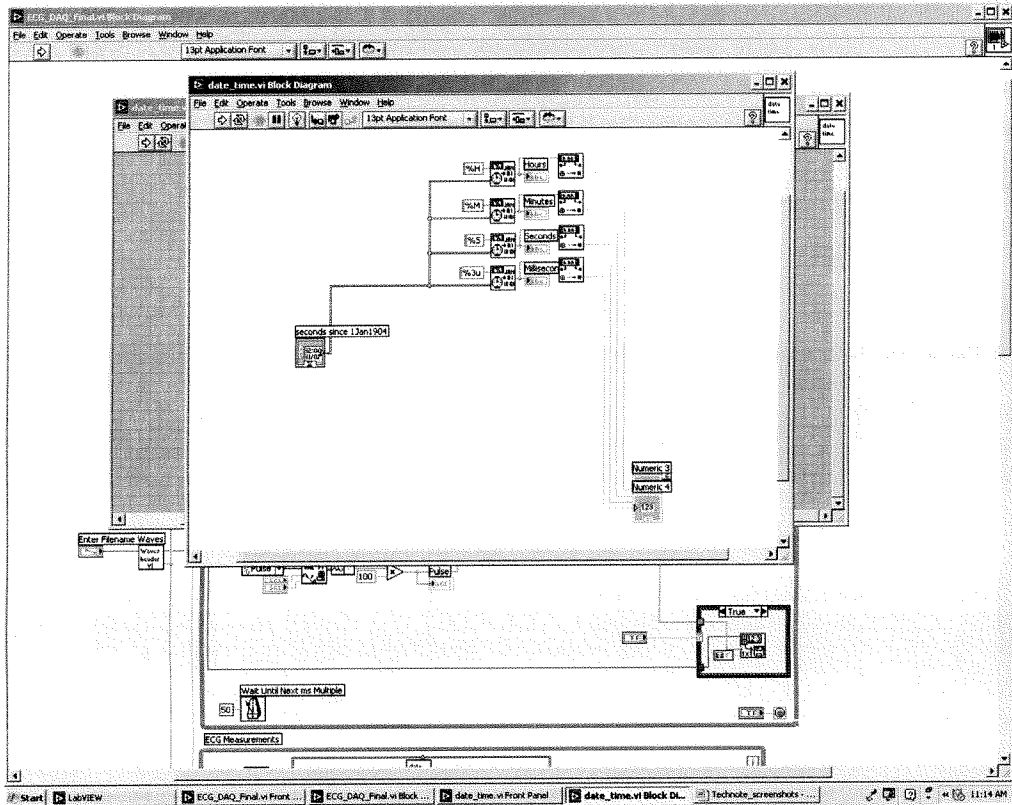

Figure 6. Temp_Header.vi

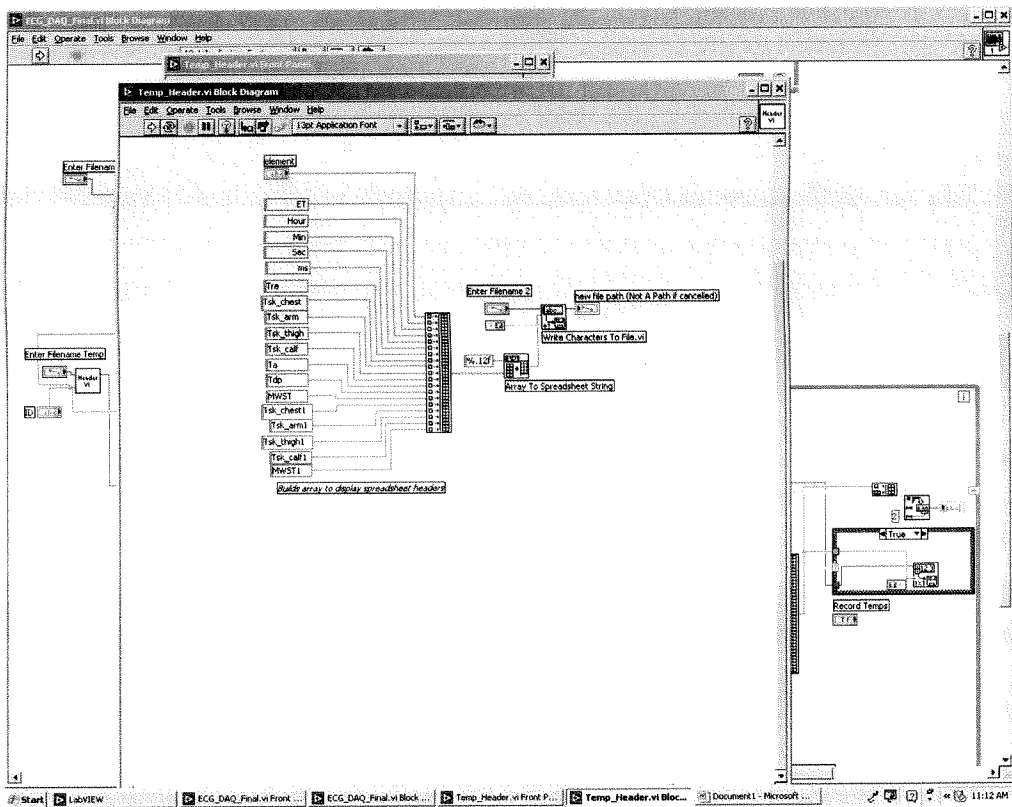

Table 1. Spreadsheet Labeling Scheme.

Column	Temp. label	ECG Label	Waves Label
1	<i>ID</i>	<i>ID</i>	<i>ID</i>
2	<i>ET</i>	<i>ET</i>	<i>ET</i>
3	<i>Hour</i>	<i>Hour</i>	<i>Hour</i>
4	<i>Min</i>	<i>Min</i>	<i>Min</i>
5	<i>Sec</i>	<i>Sec</i>	<i>Sec</i>
6	<i>ms</i>	<i>ms</i>	<i>ms</i>
7	<i>Tre</i>	<i>ECG</i>	<i>Nellcor Wave</i>
8	<i>Tsk_chest</i>		<i>Sat</i>
9	<i>Tsk_arm</i>		<i>B/P</i>
10	<i>Tsk_thigh</i>		<i>Pulse</i>
11	<i>Tsk_calf</i>		
12	<i>Ta</i>		
13	<i>Tdp</i>		
14	<i>MWST</i>		
15	<i>Tsk_chest1</i>		
16	<i>Tsk_arm1</i>		
17	<i>Tsk_thigh1</i>		
18	<i>Tsk_calf1</i>		
19	<i>MWST1</i>		

Table 2. Terminal Block Wiring Scheme.

SCXI-1102	Source
00	---
01	Tsk_chest
02	Tsk_arm
03	Tsk_thigh
04	Tsk_calf
05	Tsk_chest1
06	Tsk_arm1
07	Tsk_thigh1
08	Tsk_calf1
09	Ta
10	Tdp
11-31	unused
SCXI-1102C	Source
00	ECG
01	Nellcor Wave
02	Nellcor Sat
03	Finapress B/P
04	Finapress pulse
05-31	unused

DIAGRAMS

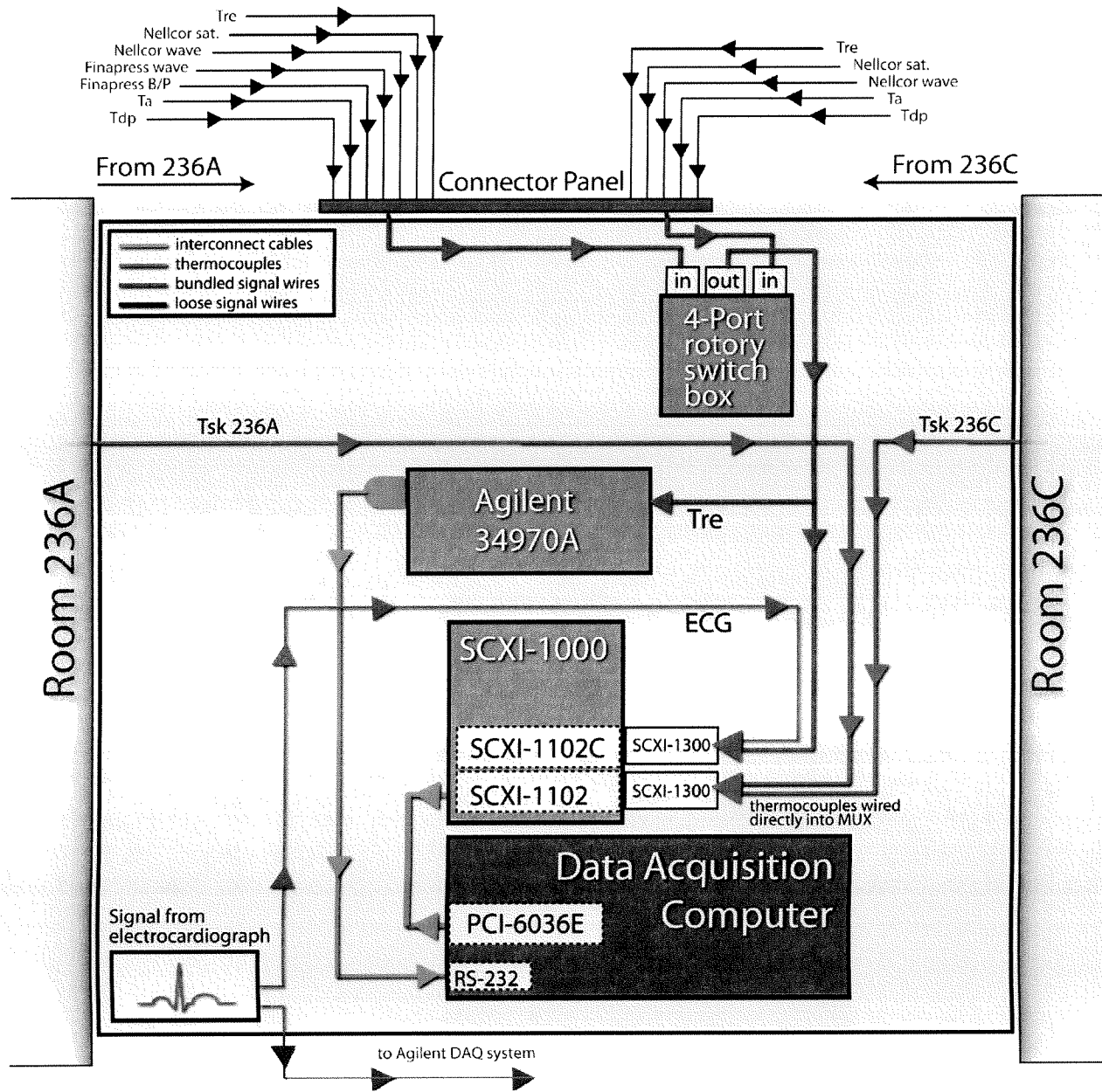

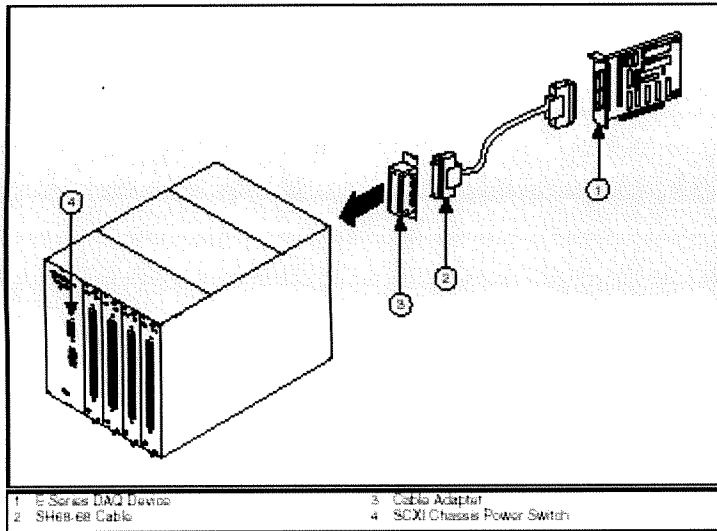
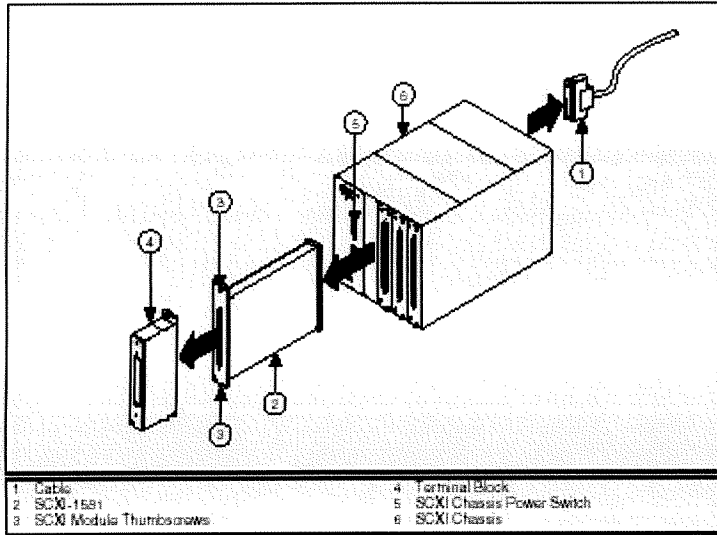

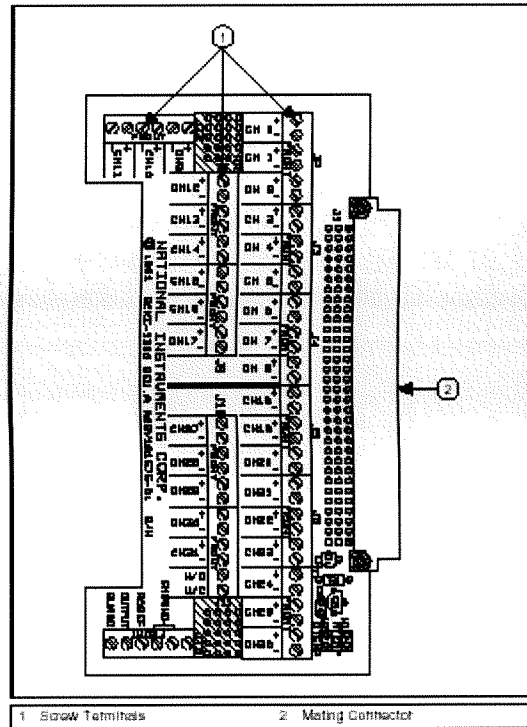
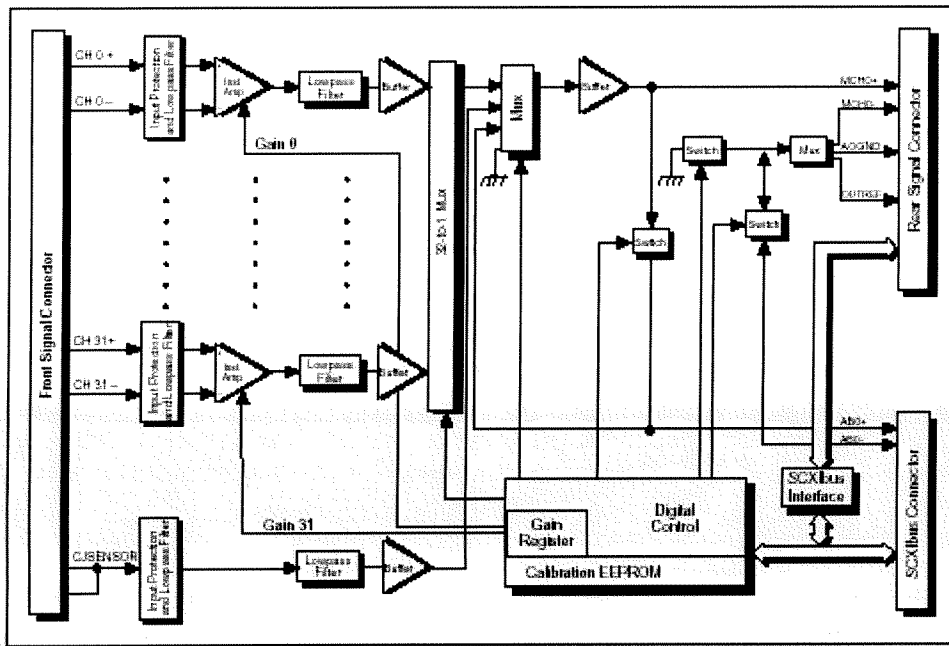

COMPONENT SPECIFICATIONS

SCXI-1000

Electrical

Supplies	SCXI-1000/ 1000DC/2000	SCXI-1001
V+		
Tolerance limits include peaks	+18.5 to +25 V	-18.5 to -25 V
Ripple (peak-to-peak)	1.5 V	1.5 V
Max load	680 mA	2.04 A
V-		
Tolerance limits include peaks	-18.5 to -25 V	-18.5 to -25 V
Ripple (peak-to-peak)	1.5 V	1.5 V
Max load	680 mA	2.04 A
+5 V		
Tolerance limits include peaks	+4.75 to +5.25 V	+4.75 to +5.25 V
Ripple (peak-to-peak)	50 mV	50 mV
Max load	250 mA	600 mA

Maximum loads are the supply current for the entire chassis. Scaling the maximum power gives the allotted current per slot, as follows:

Supplies	SCXI-1000/ 1000DC/2000	SCXI-1001
V+	170 mA	170 mA
V-	170 mA	170 mA
+5 V	50 mA	170 mA

Source Power Requirements

Line Voltage, 47-63 Hz	Max AC Current		
	SCXI-1000	SCXI-1001	SCXI-2000
120 VAC, ± 10%	0.6 A	1.25 A	0.6 A
100 VAC, ± 10%	0.5 A	1.25 A	0.5 A
240 VAC, ± 10%	0.25 A	0.75 A	0.25 A
220 VAC, ± 10%	0.25 A	0.75 A	0.25 A

SCXI-1000DC

Input voltage 12 VDC nominal
(9.5 to 16.0 VDC)
Max DC operating current
at 9.5 VDC 5.5 A

Physical

Weight

SCXI-1000 3.9 kg (8 lb 10 oz)
SCXI-1000DC 3.3 kg (7 lb 5 oz)
SCXI-1001 6.8 kg (14 lb 14 oz)
SCXI-2000 3.8 kg (8 lb 8 oz)

Refer to the following figures for the physical dimensions of the 4-slot chassis (SCXI-1000, SCXI-1000DC, and SCXI-2000) and the 12-slot chassis (SCXI-1001).

Environment

Operating temperature0° - 50°C
Storage temperature-20° - 70 °C
Relative humidity5% - 90% non-condensing

SCXI-1102

Analog Input

Input Characteristics

Number of channels	32 differential
Input signal ranges	± 100 mV (gain = 100) or ± 10 V (gain = 1)
Max working voltage (signal + common mode)	Each input should remain within ± 10 V
Input damage level	± 42 V
Inputs protected	CH<0.31>, CJSENSOR

Transfer Characteristics

Nonlinearity	0.005% FSR
Offset error	
Gain = 1	
After calibration	150 μ V max
Before calibration.....	600 μ V
Gain = 100	
After calibration	15 μ V max
Before calibration.....	100 μ V
Gain error (relative to calibration reference)	
Gain = 1	
After calibration	0.015% of reading max
Before calibration.....	0.04% of reading
Gain = 100	
After calibration	0.017% of reading max
Before calibration.....	0.1% of reading

Amplifier Characteristics

Input impedance	
Normal powered on.....	> 1 G Ω
Powered off	10 k Ω
Overload.....	10 k Ω
Input bias current	± 0.5 nA
Input offset current	± 1.0 nA
CMRR	
50 to 60 Hz, either gain	110 dB
0 Hz, gain 1	75 dB min
0 Hz, gain 100	100 dB min
Output range	± 10 V
Output impedance	91 Ω

Dynamic Characteristics

Bandwidth	1 Hz
Scan interval (per channel, any gain)	
0.012%	3 μ s

0.0061%2	10 μ s
System noise (related to input)	
Gain = 1.....	50 μ Vrms
Gain = 100.....	5 μ Vrms

Filters

Cutoff frequency (-3 dB).....	1 Hz
NMR (60 Hz)	40 dB
Step response (either gain)	
To 0.1%	1 s
To 0.01%	10 s

Stability

Recommended warm-up time	20 min.
Offset temperature coefficient	
Gain = 1.....	20 μ V/ $^{\circ}$ C
Gain = 100.....	1 μ V/ $^{\circ}$ C
Gain temperature coefficient	10 ppm/ $^{\circ}$ C

Physical

Dimensions	3.0 by 17.2 by 20.3 cm (1.2 by 6.8 by 8.0 in.)
I/O connector.....	50-pin male ribbon cable
rear connector	
96-pin male DIN C front connector	

Environmental

Operating temperature.....	0 $^{\circ}$ - 50 $^{\circ}$ C
Storage temperature	-55 $^{\circ}$ - 150 $^{\circ}$ C
Relative humidity	5% - 90% non-condensing

SCXI-1300

Electrical

(Cold-Junction Sensor on the SCXI-1300)

Sensor type..... Integrated circuit (LM35CAZ)
Accuracy1 $\pm 1.3^{\circ}\text{C}$ from 0° - 50°C
Repeatability $\pm 0.5^{\circ}\text{C}$
Output..... $0 - 0.5\text{ V}$ from 0° - 50°C (10
mV/ $^{\circ}\text{C}$)

Environmental

Operating temperature..... 0° - 50°C
Storage temperature -20° - 70°C
Relative humidity..... 10% - 90%
Indoor use only

STANDARD OPERATING PROCEDURE FOR PHYSIOLOGICAL DATA ACQUISITION SYSTEM (SCXI)

1. Turn on UPS power switch.
2. Turn on SCXI chassis power switch.
3. Turn on Agilent 34970A power switch
4. Turn on monitor.
5. **Disable all McAfee scans.** Right click on the McAfee icon on the lower MS toolbar. Move over “quick enable,” and click on all items with a check mark to the left of it. Ensure that no items have a check mark next to it.

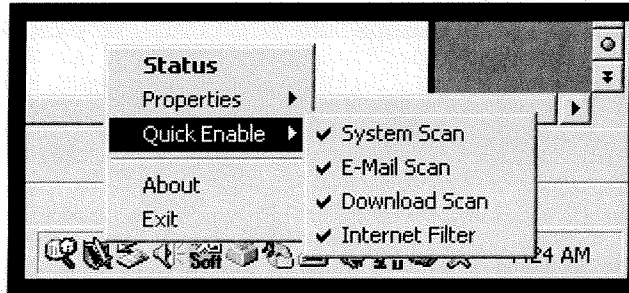

6. Disable all screen savers and power managers.
7. Launch H03-11.vi application from desktop shortcut, located on Desktop.
8. Maximize window.
9. Enter unique filename and specify path name (to be saved).
10. Enter two-digit subject number (e.g., 01, 02, 13).
11. Press “run” button (located on navigation bar) when ready to monitor data. (Note: data are being monitored but not recorded. The “record” button must be pressed to acquire data.)

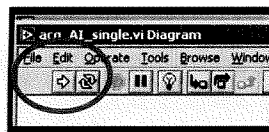

12. Allow enough time for the channels to initialize, noted by data being collected in the spreadsheet columns.
13. Press all three “record” buttons to record data to spreadsheet.
14. Press “stop” button to end both monitoring and recording.
15. Find file C:\your_unique_filename.txt and copy to Zip disk or CD-R.
16. Close program and shutdown computer.

REFERENCES

1. National Instruments Corporation. *National Instruments DAQ SCXI User Manual*. Austin, TX: 1999.
2. National Instruments Corporation. *National Instruments LabVIEW 7.0 Express Developers Suite*. Austin, TX: 2003.
3. National Instruments Corporation. *National Instruments LabVIEW Basics I and II Development Course Manual*. Austin, TX: 2002.
4. National Instruments Corporation. *National Instruments LabVIEW Measurements Manual*. Austin, TX: 1999.
5. National Instruments Corporation. *National Instruments Measurement and Automation Catalog 2003*. Austin, TX: 2000.
6. National Instruments Corporation. *National Instruments SCXI-1000 User Manual*. Austin, TX: 2001.
7. National Instruments Corporation. *National Instruments SCXI-1102 User Manual*. Austin, TX: 1998.
8. National Instruments Corporation. *National Instruments SCXI-1102c User Manual*. Austin, TX: 1998.
9. National Instruments Corporation. *National Instruments SCXI-1300 User Manual*. Austin, TX: 1999.
10. Agilent Technologies Inc. *Agilent Technologies 34970A User Manual*. Loveland, CO: 2003.