



X-Ray Fluorescence-Based Multi-Metal Continuous Emission Monitor

Development

K. James Hay, Bruce E. Johnsen, and
John A. Cooper

January 2005

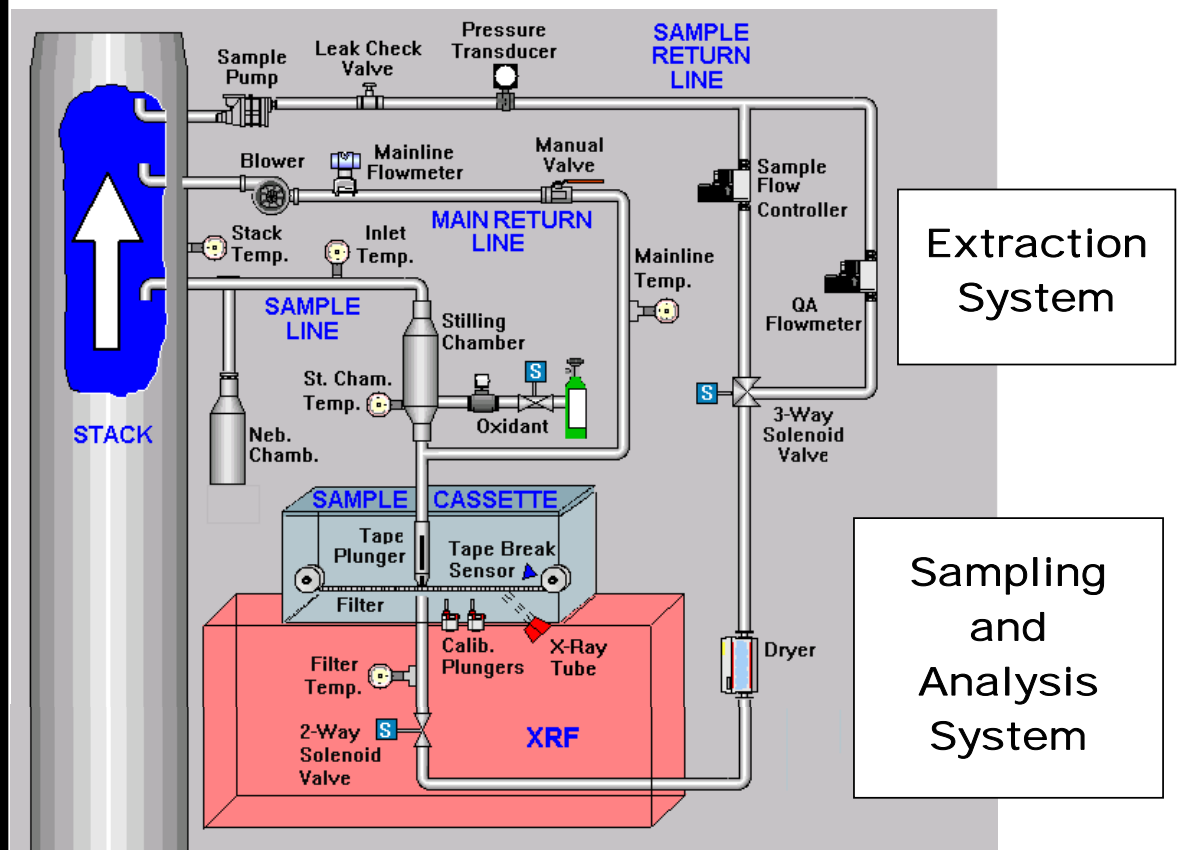

X-Ray Fluorescence-Based Multi-Metal Continuous Emission Monitor: Development

K. James Hay

*Construction Engineering Research Laboratory
PO Box 9005
Champaign, IL 61826-9005*

Bruce E. Johnsen and John A. Cooper

*Cooper Environmental Services
10170 SW Nimbus Avenue, Suite H5
Portland, OR 97223-4340*

Final Report

Approved for public release; distribution is unlimited.

Prepared for U.S. Army Corps of Engineers
Washington, DC 20314-1000

Under Work Unit #CNE-B091

ABSTRACT: Army demilitarization incinerators will need to comply with the Hazardous Waste Combustor National Emission Standards for Hazardous Air Pollutants that will regulate metals and metal compounds listed under the Clean Air Act Amendments. A large problem for these incinerator operations is limited knowledge of the types and quantities of emitted metals. Compliance may be determined only through trial burn emission tests because of this limitation. A continuous emission monitor (CEM) for multi-metals will provide the emission data, a tool to help meet compliance requirements, and the opportunity to adjust burn strategies for increased production. The XCEM multi-metal CEM was developed using x-ray fluorescence (XRF) as the analytical method and an automated sampling system that provides extractive batch sampling onto a filter tape. The system is operated with user-friendly WonderWare® software that provides automation, calibration routines, and report generation. A prototype XCEM was tested in the laboratory with a spiked gas stream against U.S. Environmental Protection Agency Reference Method 29 for four sample runs. The XCEM met the relative accuracy criteria for four of seven metals. A field-ready XCEM was built for demonstration at the 1236 Deactivation Furnace at Tooele Army Depot, Utah.

DISCLAIMER: The contents of this report are not to be used for advertising, publication, or promotional purposes. Citation of trade names does not constitute an official endorsement or approval of the use of such commercial products. All product names and trademarks cited are the property of their respective owners. The findings of this report are not to be construed as an official Department of the Army position unless so designated by other authorized documents.
DESTROY THIS REPORT WHEN IT IS NO LONGER NEEDED. DO NOT RETURN IT TO THE ORIGINATOR.

Contents

List of Figures and Tables	v
Conversion Factors	vii
Preface.....	viii
1 Introduction	1
Background.....	1
Objective	3
Approach	3
Mode of Technology Transfer	3
2 XCEM Development.....	4
XCEM Description	5
<i>Extraction System.....</i>	<i>5</i>
<i>Sampling and Analysis System</i>	<i>7</i>
<i>Control System.....</i>	<i>9</i>
Integration of Sensors.....	10
<i>Operator Accessible Control Screens.....</i>	<i>10</i>
<i>Administrator Accessible Control Screens.....</i>	<i>17</i>
Sampling Platform Modifications	19
<i>Quality Assurance Modifications.....</i>	<i>19</i>
<i>Ease-of-use Modifications</i>	<i>23</i>
<i>Safety Modifications</i>	<i>24</i>
3 Laboratory Testing.....	25
Mercury Sampling.....	25
<i>Experimental.....</i>	<i>25</i>
<i>Mercury RIF Results</i>	<i>25</i>
<i>Mercury Oxidation Automation</i>	<i>26</i>
<i>Mercury XCEM Results</i>	<i>27</i>
Method 29 Comparison Tests	27
<i>Spike Injection System</i>	<i>27</i>
<i>Test Design.....</i>	<i>30</i>
<i>XCEM Results During Method 29 Testing</i>	<i>31</i>
<i>XCEM vs M29.....</i>	<i>37</i>
<i>Method 29 and XCEM Precision and Accuracy.....</i>	<i>39</i>

4 Field-ready XCEM 43

5 Summary and Conclusions..... 46

References 48

Abbreviations and Acronyms 49

Report Documentation Page..... 51

List of Figures and Tables

Figures

1	Schematic of XCEM components minus the control computer.....	5
2	XCEM analysis system, computer control, and sampling cassette	6
3	XCEM sampling cassette	7
4	Gas sampling process in the sample cassette.....	8
5	X-ray detection process.....	8
6	Component Control screen	11
7	Diagnostics screen.....	12
8	Metal Concentration screen during M29 testing.....	12
9	Quality Assurance screen	13
10	Temperature Trend screen	14
11	Pressure Trend screen.....	14
12	Flow Trend screen.....	15
13	Concentration Trend screen.....	15
14	Data output screen.....	16
15	Alarm screen	17
16	Set QA Ranges screen.....	18
17	Set Analog Ranges screen.....	19
18	XCEM QA program.....	20
19	PLC control for the XCEM.....	21
20	Zero and span test plunger	22
21	Pd wire-mounted for QA.....	22
22	XCEM sampling cassette and XRF control panel	24
23	Schematic of Hg capture for first phase experiments	26
24	RIF Hg capture efficiency versus air flow rate through filter	26
25	XCEM elemental concentrations during M29 testing	32
26	XCEM cadmium versus other spiked metals during M29 testing.....	35
27	Comparisons of XCEM and M29 concentration by run.....	40
28	XCEM and M29 normalized concentrations by element.....	41
29	New Component Control Screen for XCEM software interface	43

30	XCEM cassettes	44
31	XCEM extraction system and cassette and chassis	44
32	XCEM with cabinet door open.....	45
33	XCEM with computer system installed at TEAD	45

Tables

1	Army hazardous waste combustors	2
2	Evaluation of spike injection options	29
3	Test conditions during M29 sampling	31
4	Elemental concentrations at XCEM and M29 Ports during pre- and post-tests	36
5	Relative accuracies of M29 Port versus XCEM Port during pre- and post-tests	36
6	Reported XCEM and M29 concentrations.....	38
7	Average metal concentrations for each sampling run	38
8	XCEM and M29 relative accuracies	39

Conversion Factors

Non-SI* units of measurement used in this report can be converted to SI units as follows:

Multiply	By	To Obtain
degrees Fahrenheit	$(5/9) \times ({}^{\circ}\text{F} - 32)$	degrees Celsius
feet	0.3048	meters
inches	0.0254	meters

* *Système International d'Unités* (International System of Measurement), commonly known as the metric system.

Preface

This study was conducted for Headquarters, Department of the Army under Program Element 063728A, “Environmental Technology Demonstration”; Project 002, “Environmental Compliance Technology”; Work Unit CNE-B091, “Hazardous Air Pollutants Technology Demonstrations.” The peer reviewer was Thomas Logan, U.S. Environmental Protection Agency, Office of Air Quality and Planning and Standards, Air Measurements and Quality Group.

The work was performed by the Environmental Process Branch (CN-E) of the Installations Division (CN), Construction Engineering Research Laboratory (CERL). The CERL Principal Investigator was Dr. K. James Hay. Part of this work was contracted to Cooper Environmental Services under DACA42-02-P-0072, DACA42-01-R-008, and DACA42-00-P-0245. The technical editor was Linda L. Wheatley, Information Technology Laboratory. Dr. Kirankumar V. Topudurti is Chief, CN-E, and Dr. John T. Bandy is Chief, CN. The associated Technical Director was Gary W. Schanche. The Director of CERL is Dr. Alan W. Moore.

CERL is an element of the U.S. Army Engineer Research and Development Center (ERDC), U.S. Army Corps of Engineers. The Commander and Executive Director of ERDC is COL James R. Rowan, EN, and the Director of ERDC is Dr. James R. Houston.

1 Introduction

Background

The U.S. Environmental Protection Agency (EPA) is developing regulations for Hazardous Waste Combustors (HWC) as part of Title III of the 1990 Clean Air Act Amendments (CAAA) in the form of a National Emission Standards for Hazardous Air Pollutants (NESHAP). The U.S. Army possesses many demilitarization furnaces that will need to comply with these regulations. Of most concern is being able to meet the requirements for metals and metal compounds listed under the CAAA. These incinerator operations have a large problem because of limited knowledge of the types and quantities of metals emitted. Compliance may be determined only through trial burn emission tests because of this limitation. These tests are expensive and require worst-case scenario burns. The air permits that are then issued are based on these worst-case burns and impose limitations on the demilitarization facilities. A continuous emission monitor (CEM) for metals would provide the emission data, a tool to help meet compliance requirements, and the opportunity to adjust burn strategies for increased production and sustainability. In addition, the HWC NESHAP suggests that a CEM would be the preferential method of emission accountability.

Multi-metal CEMs being developed are based on elemental sensors using laser-induced breakdown spectroscopy (LIBS) or inductively coupled plasma (ICP). None of the LIBS monitors has successfully met the EPA-proposed Performance Specification 10 (PS-10 1996) for continuous multi-metal monitors. Only one of the ICP units, developed by Thermo Jarrell Ash Corporation, has been successful in meeting the relative accuracy (RA) criteria of the PS-10 (Seltzer 2000). The multi-metal CEMS technology appears to have practical limitations such as its complexity, high initial cost, and high operating costs. The U.S. Army Engineer Research and Development Center, Construction Engineering Research Laboratory (ERDC/CERL) decided to pursue the development of the X-ray fluorescence (XRF)-based continuous emission monitor (XCEM) because it had the potential to be a reliable and accurate CEM without these limitations.

The basic approach of the XCEM is to draw a continuous representative sample of stack gas to a stilling chamber where a smaller metered sample is extracted and passed through a chemically treated filter that collects metals in the particu-

late and vapor phases. Following sampling, the filter is passed through an XRF analyzer where the masses of up to 19 metals are measured. This approach was originally tested in 1997 at an EPA test incinerator, where the filters were analyzed offline (French 1998). Cooper Environmental Services (CES) further developed this method into an online system tested under the ERDC/CERL Waste Minimization and Pollution Prevention Program at MSE Technology Applications, Inc.'s (MSE-TA's) research incinerator in Butte, MT (Bryson et al. 2000). The results were encouraging because the XCEM met the PS-10 RA requirements for chromium (Cr) and lead (Pb). Many of the other requirements were unmet, however, and further development was needed. It was at this point that ERDC/CERL began funding the development of XCEM technology under their Hazardous Air Pollutants (HAP) program. Table 1 lists the Army's 19 existing, new, or planned hazardous waste combustors (Josephson 2003).

Table 1. Army hazardous waste combustors.

Location	Type	Waste Treated	Status	GO or CO
Sierra AD	APE 1236	CS	Existing	GO
Tooele AD	APE 1236	CS	Existing	GO
Tooele AD	APE 1236	Test Furnace – CS	Existing	GO
McAlester AAP	APE 1236	CS	Existing	GO
Hawthorne AAP	APE 2210	CS	New	CO
Fort Richardson	APE 1236	CS	New	GO
Kansas AAP	APE 1236	CS	Existing	CO
Crane AAP	APE 1236	CS	New	GO
Lake City AAP	APE 1236	Off-spec conventional	Existing	GO
Picatinny Arsenal	APE 1236	Waste R&D propellants	New	GO
Pine Bluff Arsenal	Fluidized Bed	Pyrotechnics and Obscurants	New	GO
Pine Bluff Arsenal	APE 1236	Off-spec pyrotechnics	Existing	GO
Radford AAP	Kiln	Off-spec propellants	Existing	GO
Deseret CA	Chemical	Chem	Existing	GO
Umatilla AD	Chemical	Chem	New	GO
Pine Bluff Arsenal	Chemical	Chem	New	GO
Anniston AD	Chemical	Chem	New	GO
Pueblo CA	Chemical	Chem	Planned	GO
Anniston AD	Kiln	De-Painting wastes	Planned	GO

GO – Government Owned
 CS – Conventional Stockpile
 AD – Army Depot

CO – Contractor Owned
 Chem – Chemical Stockpile
 AAP – Army Ammunition Plant

CA – Chemical Activity
 APE - Army Peculiar Equipment
 R&D – Research and Development

Objective

The overall objective of the HAP program is to develop cost-effective technologies to help the Army meet current and future demands of HAP regulations. The specific objective of the work reported here was to develop a multi-metal CEM for use at an Army installation. It is important that this monitor be easy to transition to the Army by incorporating characteristics that make it compatible with Army operations and expectations, such as user friendliness and affordability. Ultimately, the desired exit criterion under the HAP Program is for the monitor to meet the complete requirements of the proposed PS-10 under field conditions. This objective will be pursued in a follow-on report.

Approach

The XCEM was developed under this project through contracts with CES (DACA42-00-P-0245 and DACA42-01-R-008). A prototype was constructed incorporating necessary improvements determined from the Butte testing, such as user friendliness, automation, and the capability to monitor mercury (Hg). This prototype was then tested in the laboratory by comparing it against the EPA Reference Method 29 (M29). A new monitor was constructed and readied for demonstration at the 1236 production deactivation furnace at Tooele Army Depot (TEAD), UT.

Mode of Technology Transfer

This technology was developed through the ERDC/CERL HAP Program, which uses 6.3 advanced development and field-testing funds. The HAP Program is part of the Army Environmental Quality Technology (EQT) Program. As part of the EQT process, a technology transfer plan is being developed by the Army Environmental Center (AEC) for this technology and other qualified technologies under the HAP program. A User's Guide and a Resource Manual have been developed to accompany the XCEM for field training and reference (CES 2001a,b).

This report will be accessible through the World Wide Web (WWW) at URL:
<http://www.cecer.army.mil>

2 XCEM Development

Regulators, government agencies, and industry have expressed support for development of instrumentation capable of continuous measurement of metals from stationary sources. The EPA recently reemphasized its position in the final Maximum Achievable Control Technology (MACT) standard for hazardous waste incinerators. In this standard, continuous monitoring is placed at the top of the Compliance Monitoring Hierarchy and underscored as the “strong preference” (Federal Register [FR] 52925). The incentives provided in the MACT standard for using multi-metal CEMs include bypassing feedstock measurement and decreased requirements for performance testing. In addition, end users of multi-metal CEMs have real-time access to process control information and the potential for enhanced public acceptance.

Over the past few years, CES has developed instrumentation capable of continuous multi-metal measurement. The CES approach uses XRF to measure stack gas particulate matter (PM) that has been concentrated on a filter. In 1997 CES demonstrated the feasibility of this approach using an offline continuous sampling system at an EPA test incinerator in North Carolina (French 1998). Further adaptation of the approach led to an online XCEM capable of determining metal concentrations every 10 to 15 minutes. The prototype XCEM was successfully tested in 1999 at the MSE-TA test facility (Bryson et al. 2000). During these tests, the XCEM demonstrated an RA for two MACT metals, Cr and Pb, of less than 20 percent. Further refinement was needed, however, to meet EPA’s PS-10. Specifically, the MSE-TA report recommended that the following tasks be performed:

1. **Sensor Integration:** Integrate temperature and pressure sensors into a user-friendly computer interface.
2. **Sampling Platform Modifications:** Modify the sampling platform for improved ease-of-use, and integrate an automated quality assurance (QA) program into the sampling platform design.
3. **Mercury Sampling:** Conduct additional laboratory testing for Hg capture efficiency and automation of XCEM Hg oxidation system. Conduct further Hg RA testing.
4. **Spike Injection System:** Develop an injection method capable of supplying adequate concentrations of metals for routine testing. Conduct further XCEM RA testing using the new spike injection system.

This chapter presents a general description of the XCEM and the improvements to the XCEM that address the first two recommendations made in the MSE-TA report: sensor integration and sampling platform modifications.

XCEM Description

Figure 1 shows major XCEM components and relative flows. The XCEM comprises three major subsystems: an extraction system, sampling and analysis system, and control system.

Extraction System

The extraction system is designed to transport a representative sample of stack gas from the stack to the filter tape. It includes a probe, 1-inch-diameter tubing, stilling chamber, and flow measurement and control components. Temperature is measured at five locations, and all tubing prior to the filter is heat traced.

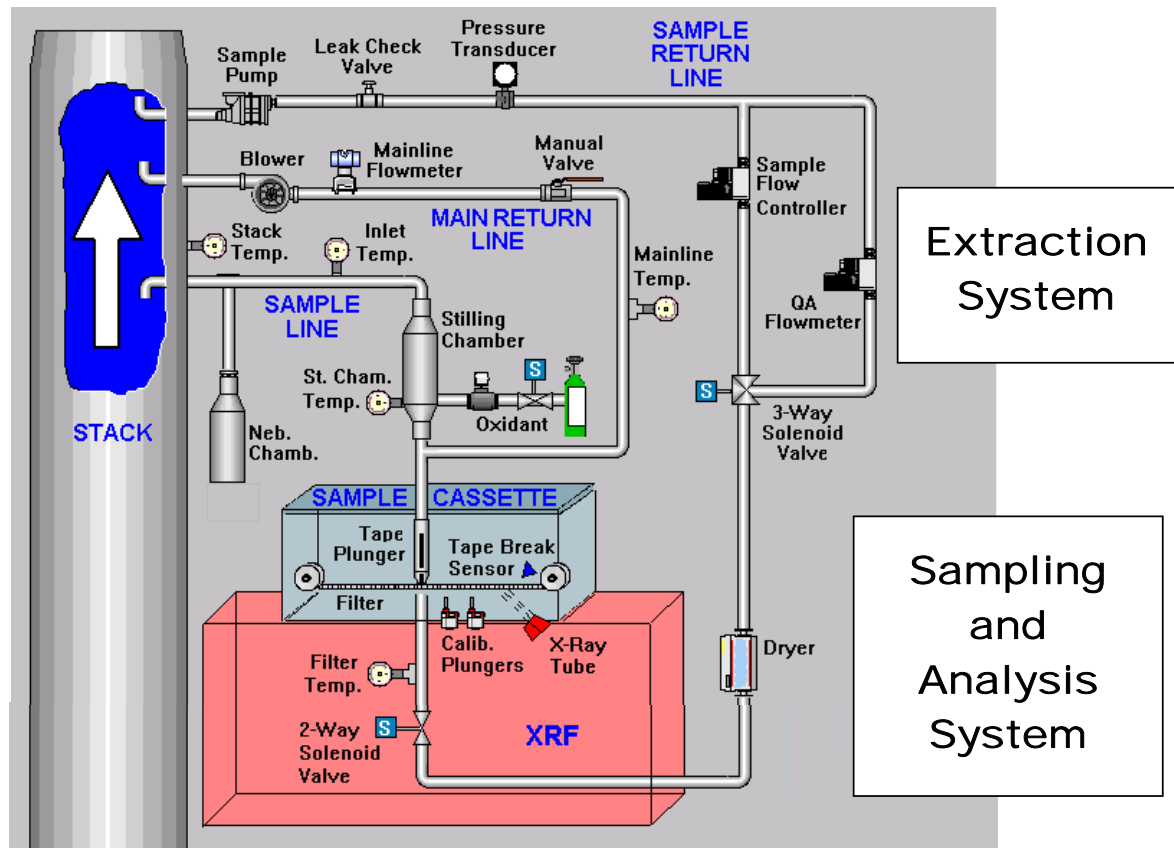

Figure 1. Schematic of XCEM components minus the control computer.

The extraction system draws an isokinetic sample from the stack using a large-diameter probe. The gas is transported to a 3-inch-diameter stilling chamber, which slows the gas velocity, decreasing the Stokes number so that small quantitative subsamples can be extracted. The subsample, less than 1 percent of the gas sample in the stilling chamber, is removed from the stilling chamber through a one-quarter-inch-diameter extraction tube. Inside the extraction tube, a dilution and mixing chamber allows the addition of chlorine and other gases to dry and oxidize the sample. The oxidized sample is then drawn through a resin-impregnated filter (RIF) where particulate and vapor phase metallic species are concentrated for subsequent XRF analysis. After passing through the filter, the gas is dried with a Universal Analyzer dryer, measured with a mass flow controller, and returned to the stack through a diaphragm sampling pump. A post-filter pressure transducer provides assurance that no leaks are present in the system. The volume of the remaining 99 percent of the stilling chamber stack gas is measured and returned to the stack using a regenerative blower. The entire extraction system is shown in Figure 1.

The XCEM software interface controls key extraction system components including: thermocouples, a pressure transducer, blower, pump, and several flowmeters. Temperature, flow, and pressure data are automatically recorded in an electronic database. Figure 2 shows the sample cassette atop the XRF analyzer next to the computer control enclosure.



Figure 2. XCEM analysis system, computer control, and sampling cassette.

Sampling and Analysis System

Once the stack gas subsample leaves the stilling chamber, it is drawn into a sample cassette (Figure 3). This cassette contains a stepper motor, infrared tape break sensor, and filter tape mounted on reels. Stack gas entering the cassette is transported through the extraction tube across a 0.3 cm² spot on the filter tape. Every 12 minutes the filter tape in the cassette is advanced from the sampling location to the analysis position located 1 inch away. A Kevex-Spectrace QuanX XRF instrument (Thermo Kevex, Thermo Electron Corp., Waltham, MA) then analyzes the metals mass concentrated on the filter. Following analysis, the sample is advanced again and collected on a take-up reel. Figure 4 shows a schematic of this process. During the XRF analysis, x-rays are emitted from the x-ray tube onto the filter tape sample. Resultant x-rays are produced that are characteristic of the metals on the sample (Figure 5). These x-rays are detected by the XRF detector and a signal that is proportional to the mass for each metal is sent to the computer. The computer acquires these signals and compares it to known mass per signal ratios developed during calibration. XRF results are then reported as micrograms per sample.



Figure 3. XCEM sampling cassette.

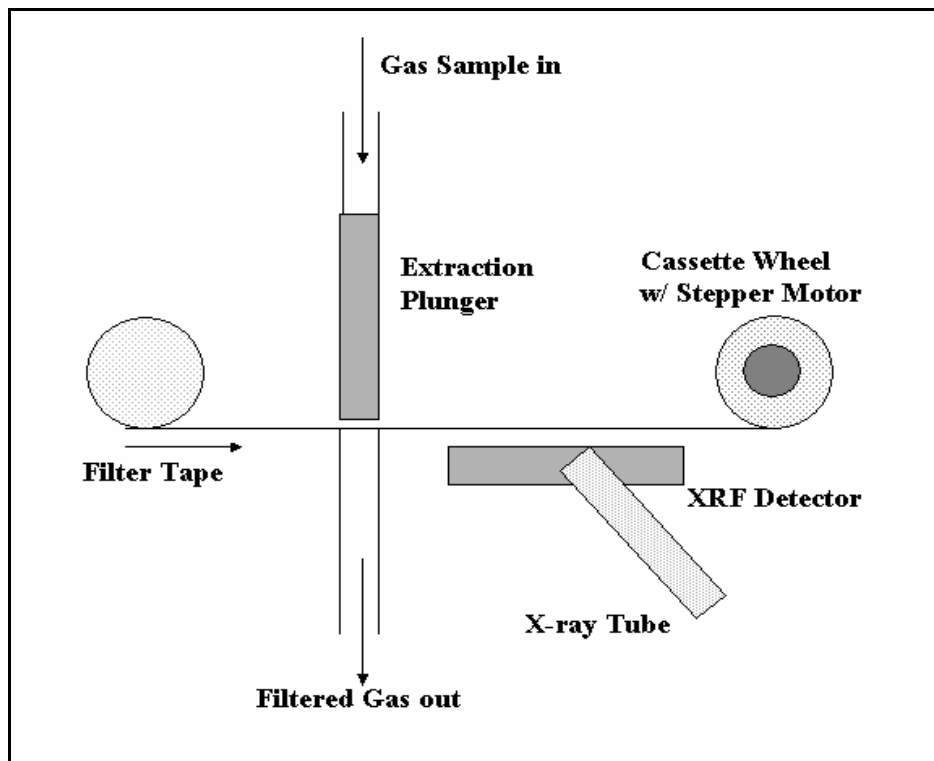

Figure 4. Gas sampling process in the sample cassette.

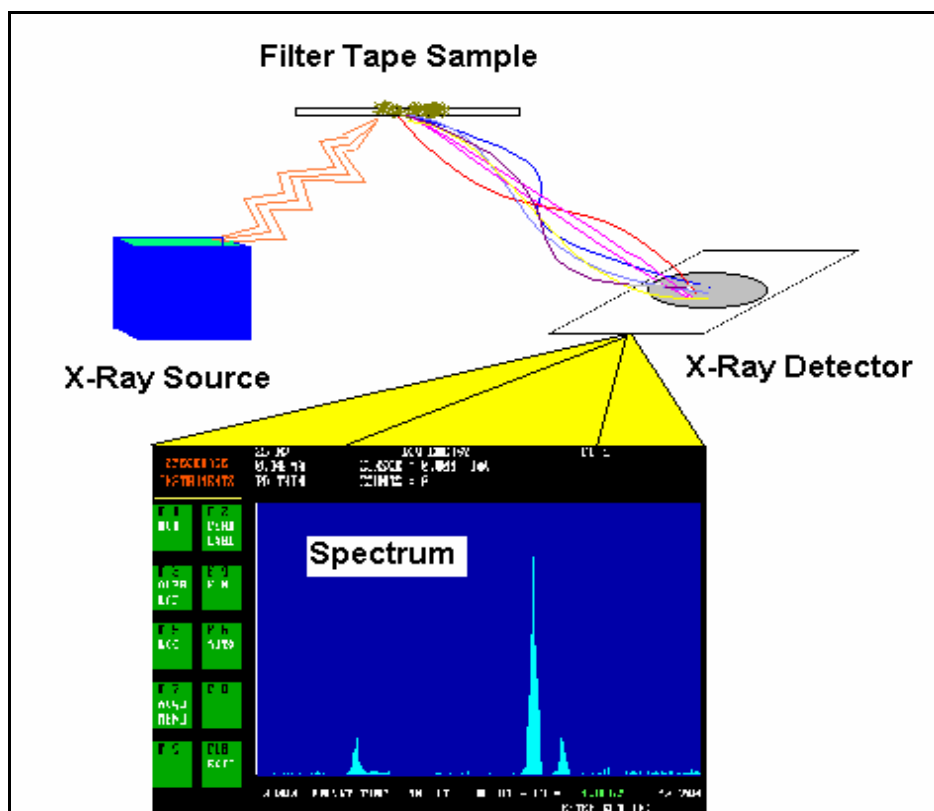

Figure 5. X-ray detection process.

Since XRF is nondestructive, metal mass on the take-up reel is available if needed for subsequent chemical analysis. Each cassette holds a 2–4 week supply of tape and is engineered to be portable and easily removed. It is anticipated that each XCEM will come with two cassettes, which will enable the operator to exchange tapes in a clean environment and transport the entire cassette into the field. An additional benefit of having two cassettes is a duplication of components. In the event of equipment failure, the duplicate cassette can be in place within a few minutes, decreasing instrument downtime. The cassette is designed to fit directly onto the XRF instrument and includes interlocks to prevent the XRF from operating when the cassette is not in place.

The QuanX energy dispersive XRF has an electronically cooled lithium drifted silicon detector. Located immediately above the detector is a permanently mounted palladium rod, which is analyzed with each sample to determine if instrument drift is occurring. As an additional QA source, a rod is mounted on a pneumatic plunger near the detector. This rod has an epoxy coating with significant quantities of Cadmium (Cd), Cr, Hg, and Pb. Each day the XCEM activates the plunger and extends the rod into the analysis area for span and zero tests.

Detection limits for the XRF are determined by filter blank concentrations and analysis time. If a sample is taken every 10 minutes, detection limits for all of the MACT metals are less than 3.5 $\mu\text{g}/\text{m}^3$ (micrograms per cubic meter). Detection limits can be improved by increasing sampling time. The XRF automatically determines metals concentration and uncertainties. The data are then transmitted to a second computer, which runs the WonderWare® software control interface.

Control System

XCEM flows and temperatures are controlled using WonderWare® software interface on a personal computer. This interface records pressure, temperature, metals concentrations, QA data, and sampling times, and prints a hard copy report with each sample analysis. An electronic copy of the data is kept in a WonderWare® database, which cannot be altered without being flagged. These data can be made available over a local intranet or a secure Internet website. A second personal computer runs the XRF software.

Automating the XCEM to make it a user-friendly tool was a primary objective of this work. The automation and control features that were developed are discussed in the next section.

Integration of Sensors

The MSE-TA report recommended computer control of XCEM components, data storage, and QA. In response to this recommendation, the XCEM has been fully automated using a WonderWare® software interface. This interface includes a variety of screens that allow the user to control components, diagnose problems, view concentration trends, and output data. Each screen contains an alarm signal in the lower right-hand corner that flashes if some component of the system is not working or if the metals' concentrations exceed user-defined limits. The XCEM interface is password protected and can be accessed by either an operator with limited XCEM control or an administrator with full user rights.

Operator Accessible Control Screens

The computer interface allows the user to view a number of screens that present operational data for control of the XCEM. Those screens are presented below.

Component Control Screen

The *Component Control* screen (Figure 6) contains a schematic of the XCEM system. This schematic includes icons representing key XCEM components and real-time data for temperatures, pressures, and flows. Adjacent to the schematic, a *System Start/Stop* button begins and completes sampling with a single click. This screen also provides users with the option of manually adjusting individual components of the sampling system. Users logged on as operators can control heaters or turn the pump and blower on by double clicking on the appropriate icon and responding to the pop-up dialogue box. Users logged on as administrators have the further capability of controlling flow rates and valves. This page is considered the “home page” for the interface and can be accessed from any screen by clicking on the house icon in the lower left-hand corner of the page.

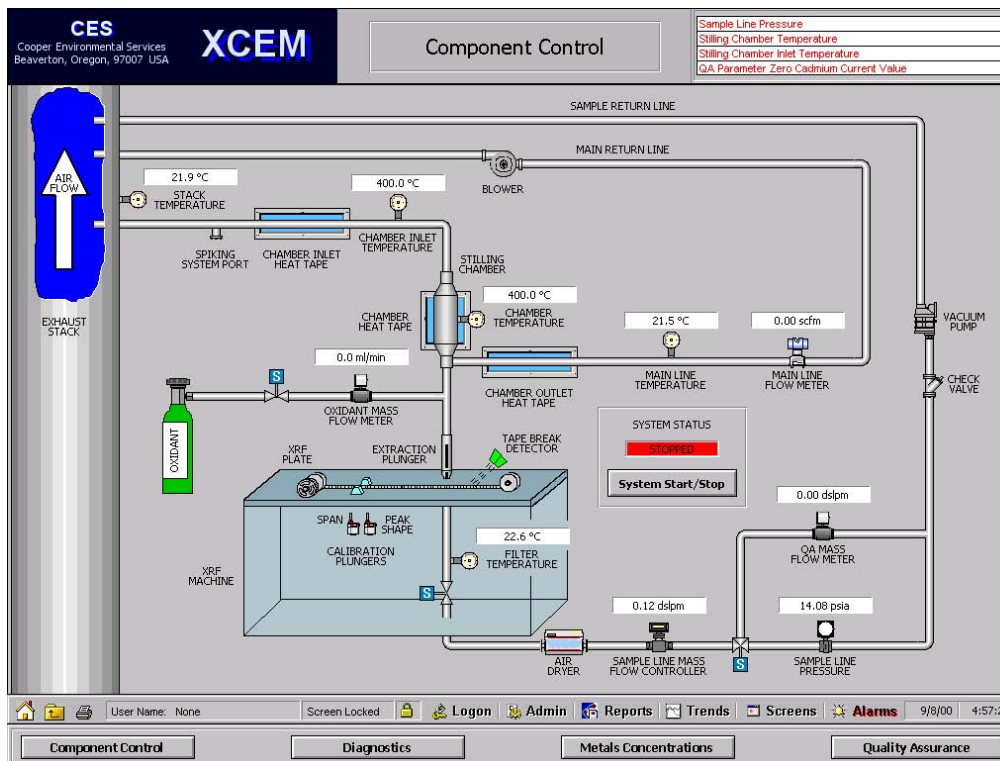

Figure 6. Component Control screen.

Diagnostics screen

The *Diagnostics* screen (Figure 7) is a read-only interface designed to give the operator an easy-to-read system status check. The *Diagnostics* screen displays current temperature, flow, QA and metal concentrations and lights indicating if the system is functioning properly. Buffer ranges defined by the system administrator for each component are displayed on this screen. Measurements that fall within these buffer ranges are given a green light. Measurements slightly beyond the range are signified with a yellow light, and data significantly beyond the buffer range warrant a red light. Yellow and red lights are listed as alarms by the XCEM interface.

Metals Concentration screen

Up to 20 real-time metals' concentrations are displayed on the *Metals Concentration* screen (Figure 8). Operators can graph up to eight of these concentrations simultaneously and access a 12-hour rolling average chart that displays High Volatile Metals (HVM), Semi-Volatile Metals (SVM), and Low Volatile Metals (LVM). The chart was developed in accordance with the MACT rule for hazardous waste incinerators and can be set to include buffer ranges to alert the operator of high metal concentrations in the stack. As with all graphs within the

XCEM interface, the Metals Concentration graph's time axis can be set to display data for periods between a few hours up to 6 weeks.

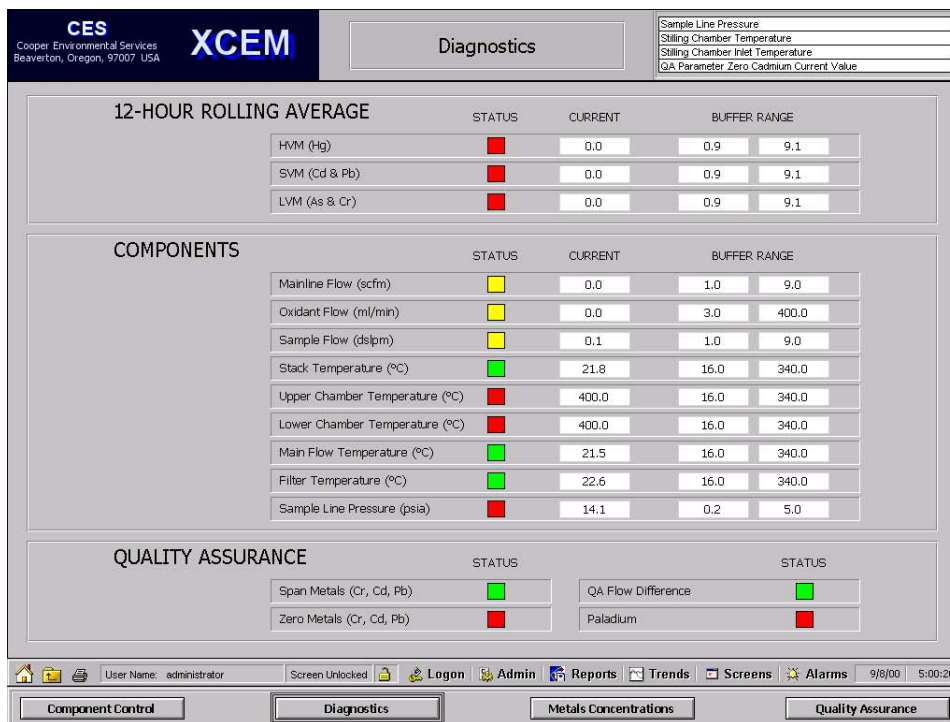

Figure 7. Diagnostics screen.

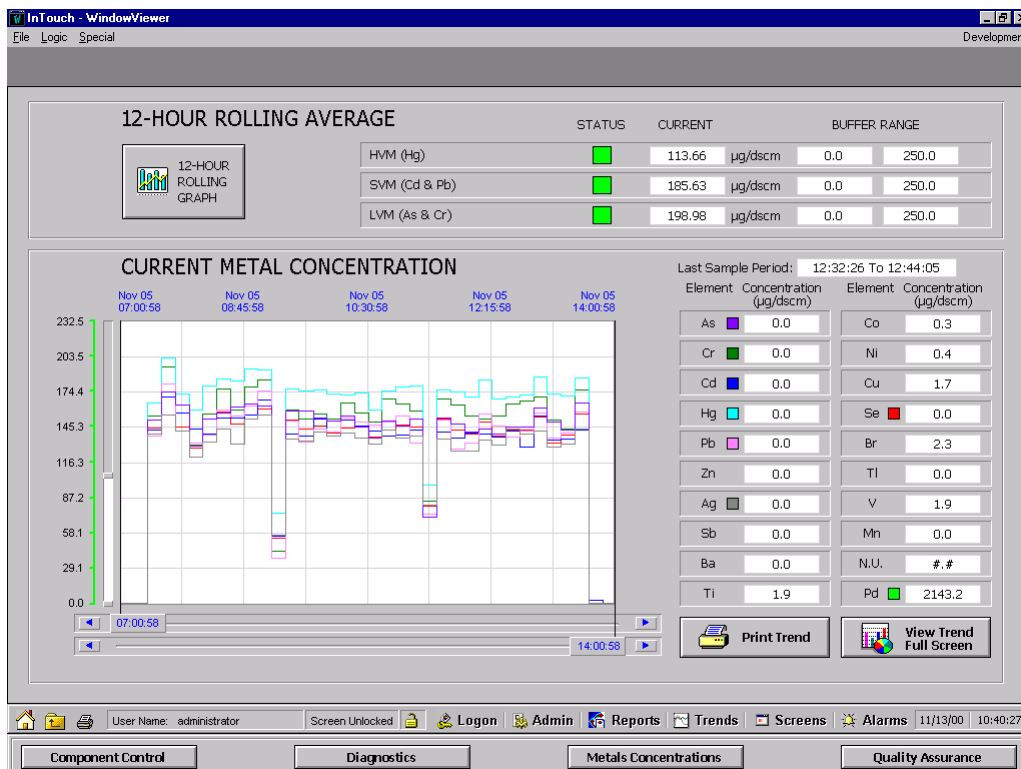

Figure 8. Metal Concentration screen during M29 testing.

Quality Assurance screen

The *Quality Assurance* screen (Figure 9) is a read-only display that shows historical QA results. Palladium (Pd) is measured with each sample while daily span and zero tests for key metals are conducted at user-defined times. The time at which the latest QA check was undertaken is also listed in a text box on the right-hand side.

Trends screens

Trends for temperature, pressure, flow, and metals concentrations are all displayed as individual screens by the XCEM computer interface (Figures 10–13). Each screen can display up to eight trends simultaneously and can be customized to include combinations of data from the other trends screens. For example, stack temperature and metals concentrations can be graphed simultaneously. All figures can be printed by using the *Print Trend* button in the lower right-hand corner of the screen.

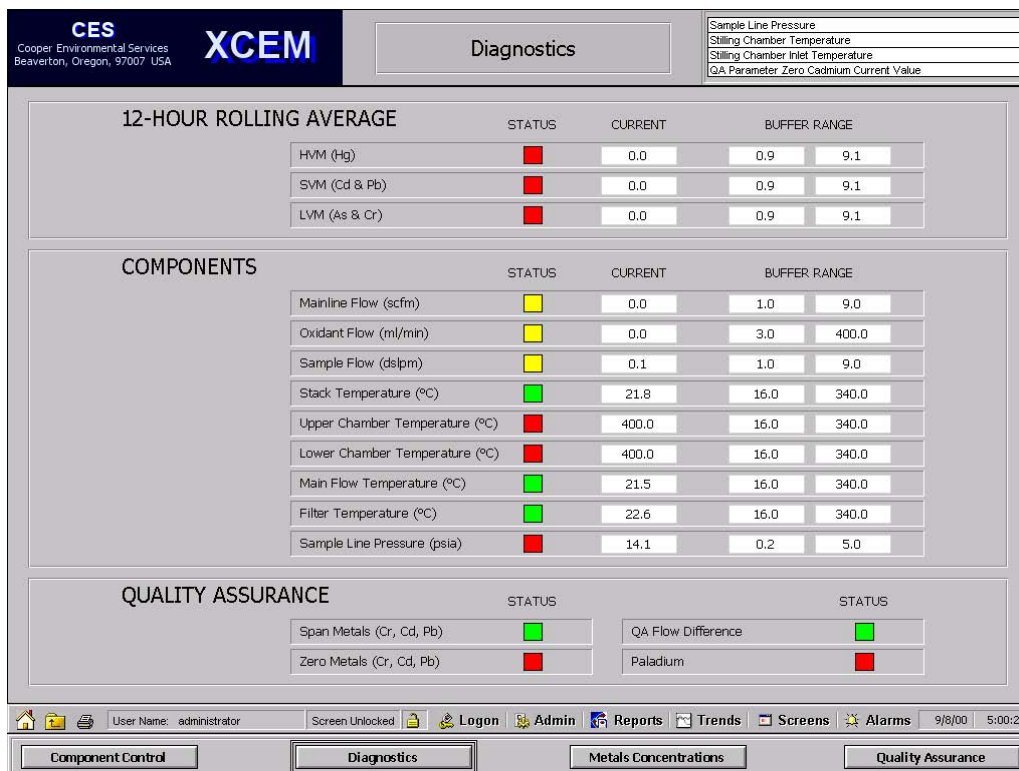

Figure 9. Quality Assurance screen.

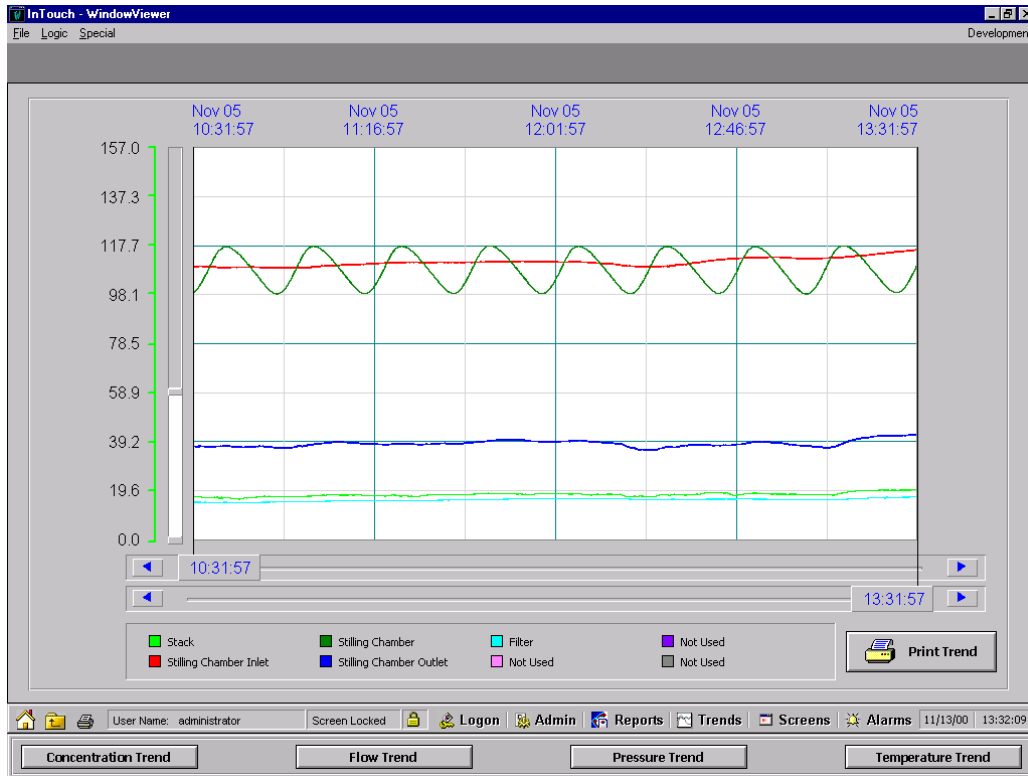

Figure 10. Temperature Trend screen.

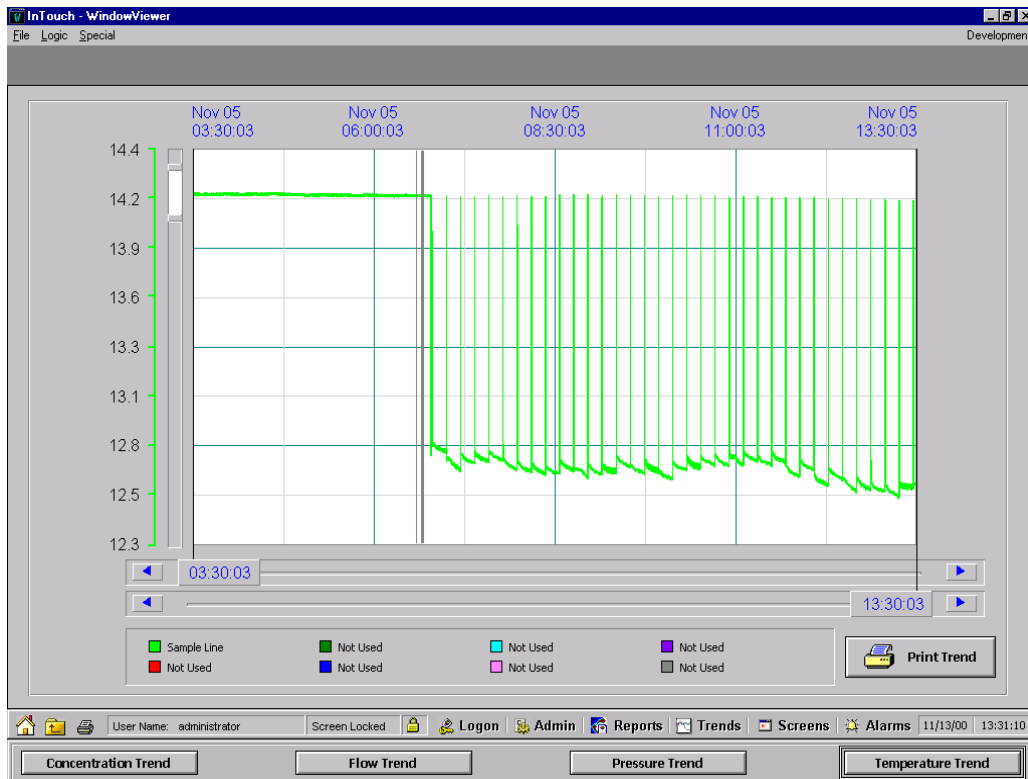

Figure 11. Pressure Trend screen.

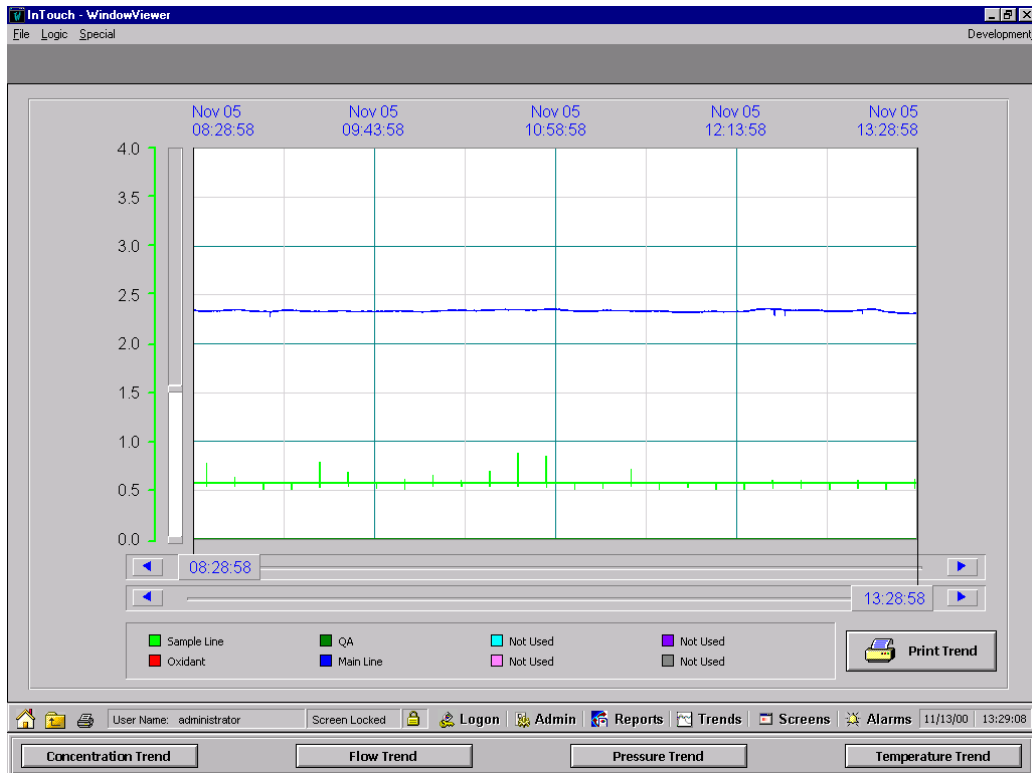

Figure 12. Flow Trend screen.

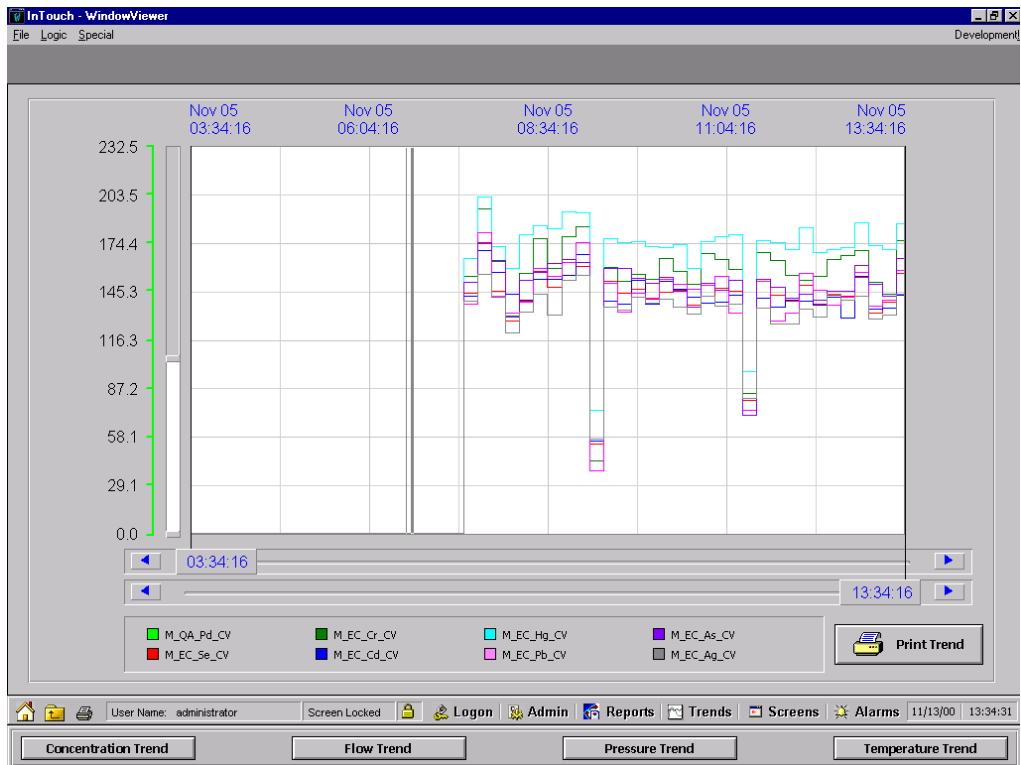

Figure 13. Concentration Trend screen.

Data output

The control program automatically saves QA and metals concentration data. XCEM operators have the option to convert the data to a comma-delimited format that is readily opened using Microsoft® Excel or other spreadsheet programs. Using the *Data Output* screen (Figure 14), the operator can select up to 6 weeks of historical data. The output is automatically averaged over a user-defined sample period. Data output includes:

1. Sample date
2. Sampling time
3. Concentrations of analyzed elements
4. Uncertainty in concentrations of analyzed elements
5. Pressure in sampling loop
6. Temperatures
7. Main line, oxidant and sample flows
8. Data flag and code if red alarm is triggered.

Data are automatically flagged if a potential problem occurred (i.e., a parameter is outside the user-defined QA limits/ranges). The XCEM administrator defines acceptable boundaries for all temperature, flow, and pressure readings as well as QA parameters, individual metal concentrations, and 12-hour average concentrations.

The screenshot shows the 'Data Output' screen in the InTouch - WindowViewer application. The window title is 'InTouch - WindowViewer' and the menu bar includes 'File', 'Logic', 'Special', and 'Development'. The main content area is divided into three sections:

- START DATE AND TIME:** Features a calendar grid with the 13th of the month highlighted. To the right are input fields for 'Start Time Hour' (set to 12) and 'Start Time Minute' (set to 33).
- DURATION OF SAMPLE:** Includes a 'Time' input field set to 6 and a 'Time Period' dropdown menu set to 'Week'. A legend indicates: N = None, W = Week, D = Day, H = Hour, M = Minute. A note states: 'Fractional values are allowed. (.25D = 6 hours, 1W = 1 Week)'. The maximum duration is noted as six weeks.
- SAMPLE INTERVAL:** Includes a 'Time' input field set to 8 and a 'Time Period' dropdown menu set to 'Minute'. A legend indicates: W = Week, D = Day, H = Hour, M = Minute, S = Second. A note states: 'Fractional values are allowed. (.2M = 2 Minutes, .5H = 30 Minutes)'. The maximum interval is noted as six weeks.
- CONTROL AND STATUS:** Shows the 'CSV Save Filename' as 'd:\ztemp\XRFTST110500'. There are 'Save to File' and 'View File' buttons. The 'Operation Result' is 'NO ERRORS' in a green box. The 'Last Error Message' is 'None'.

The bottom status bar displays: 'User Name: administrator', 'Screen Unlocked', 'Logon', 'Admin', 'Reports', 'Trends', 'Screens', 'Alarms', and the date/time '11/13/00 13:33:28'. A 'Write/Save/View CSV File' button is located at the bottom left of the window.

Figure 14. Data output screen.

For chain-of-custody purposes, neither the operator nor the administrator can change the recorded data in the XCEM database without flagging the data.

Alarms

When an alarm condition exists, a flashing red alarm signal is shown at the bottom right of each screen and a discussion of the alarm condition is shown in the upper right of each computer screen. Detailed information about the alarm can be found on the *Alarm* screen (Figure 15). Alarm conditions include filter tape breakage, diagnostic or QA parameters out of the buffer range, sampling cassette lids incorrectly mounted, and 12-hour rolling averages out of the buffer range. When an alarm condition is remedied, it remains listed in the *Alarm* screen with green, blue, or black font colors. The XCEM will continue to sample despite an alarm condition; however, data will be flagged.

Administrator Accessible Control Screens

Only an individual logged in as an administrator can set component and QA buffer ranges, scale analog readings from the instrument and bypass the normal instrumentation routines. Administrator access is password protected. The following screens are only accessible by an administrator.

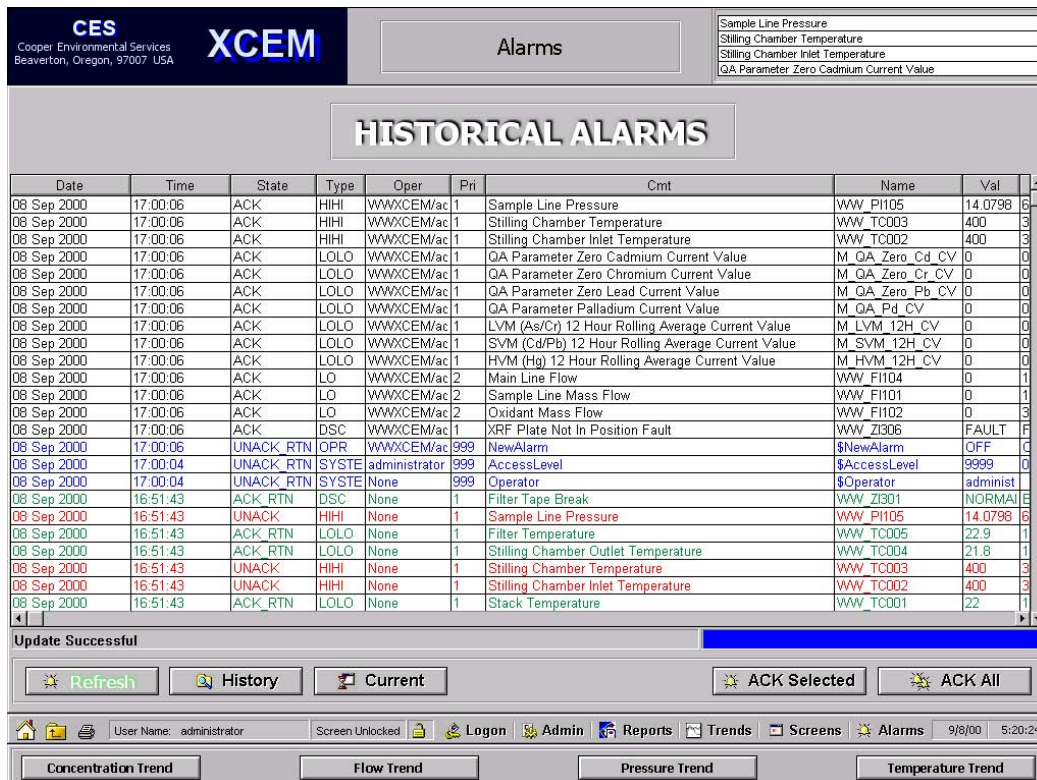

Figure 15. Alarm screen.

Set QA Ranges

Administrators can set buffer ranges using the *Set QA Ranges* screen (Figure 16). Low and high target ranges are entered on this page. Measurements that fall within the target range will give a green light on the *Diagnostics* screen. Red light ranges are also defined. When measured data lies between the target range and red light range, a yellow light is displayed on the diagnostics screen and an alarm is signaled.

Administrators using the *Set QA Ranges* screen can also set the hour of the day that a QA analysis will occur, conduct an immediate zero/span test or a peak shape test, and view milli-ampere (mA) readings for instrumentation.

Set Analog Ranges

Administrators also have access to the *Set Analog Ranges* screen for XCEM (Figure 17). This screen relates the 4 to 20 mA signal received by components to a scale used by the program. For example, a flow meter may have a 4 mA signal designated as 0 scfm (standard cubic feet per minute) and a 20 mA signal designated as 12 scfm using this screen.

SET COMPONENT AND QA RANGES

		Target Range		Red Light			Buffer Range		Red Light	
		Low	High	Low	High		Low	High	Low	High
Sample Line Mass Flow	FI101 (dspm)	1.0	9.0	0.0	10.0	HVM (Hg)	0.9	9.1	0.5	9.5
Oxidant Mass Flow	FI102 (ml/min)	3.0	400.0	0.0	450.0	SVM (Cd & Pb)	0.9	9.1	0.5	9.5
Main Line Flow	FI104 (scfm)	1.0	9.0	0.0	10.0	LVM (As & Cr)	0.9	9.1	0.5	9.5
Sample Line Pressure	PI105 (psia)	0.2	5.0	0.0	6.0	Palladium (Pd)	0.9	9.1	0.5	9.5
Stack Temperature	TC001 (°C)	16.0	340.0	15.0	350.0	Span Chromium	0.9	9.1	0.5	9.5
Chamber Inlet Temperature	TC002 (°C)	16.0	340.0	15.0	350.0	Span Cadmium	0.9	9.1	0.5	9.5
Chamber Temperature	TC003 (°C)	16.0	340.0	15.0	350.0	Span Lead	0.9	9.1	0.5	9.5
Chamber Outlet Temperature	TC004 (°C)	16.0	340.0	15.0	350.0	Zero Chromium	0.9	9.1	0.5	9.5
Filter Temperature	TC005 (°C)	16.0	340.0	15.0	350.0	Zero Cadmium	0.9	9.1	0.5	9.5
QA Flow Difference	(%)		99.0		100.0	Zero Lead	0.9	9.1	0.5	9.5

QA STATUS AND PARAMETERS

Length of Sampling/Analysis Time: 0 minutes 0 seconds

Set QA Analysis Time: 0 hour 0 minute

Enable QA Analysis:

View Component mA Values:

Immediate Zero/Span Request:

Immediate Peak Shape Request:

Zero/Span Run Status: Peak Shape Run Status:

User Name: administrator | Screen Unlocked | Logon | Admin | Reports | Trends | Screens | Alarms | 9/8/00 5:21:13

Figure 16. Set QA Ranges screen.

CES
Cooper Environmental Services
Beaverton, Oregon, 97007 USA

XCEM

Set Analog Ranges

Sample Line Pressure
Stilling Chamber Temperature
Stilling Chamber Inlet Temperature
QA Parameter Zero Cadmium Current Value

ANALOG SCALING VALUES

			Scaling Range		Current Value
			Minimum	Maximum	
Sample Line Mass Flow Meter	FI101	(0-999.9 dslpm)	0.0	5.0	0.1
Oxidant Mass Flow Meter	FI102	(0-999.9 ml/min)	0.0	500.0	0.0
QA Mass Flow Meter	FI103	(0-999.9 dslpm)	0.0	5.0	0.0
Main Line Flow Meter	FI104	(0-999.9 scfm)	0.0	12.0	0.0
Sample Line Pressure Meter	PI105	(0-999.9 psia)	0.0	15.0	14.1
Sample Line Flow Setpoint	FIC201	(0-999.9 dslpm)	0.0	5.0	2.0 12800 Cnts

XRF PARAMETERS

Set CSV File Name: G:\Results.CSV

Set CSV File Offset: 0

Last File Exists Status Check: 0 Last File Read Status: 0

Set Archival File Path: D:\XRF Archival

Last Archival Initiate Status: 0 Last Archival Status: 0

Set CSV Conversion File Name: D:\ztemp\Parse_Results.exe

Set XRF Results Text File Name: G:\Results

User Name: administrator Screen Unlocked Logon Admin Reports Trends Screens Alarms 9/8/00 5:22:01

Set Component/QA Ranges Set Analog Ranges Loop Tuning PLC Status CSV Tool I/O Forces

Figure 17. Set Analog Ranges screen.

Sampling Platform Modifications

The XCEM sampling platform was modified to provide automated QA features and improve operator ease-of-use.

Quality Assurance Modifications

The XCEM was reengineered to include an automated, user-friendly QA program (Figure 18). A WonderWare® software package has been developed with a custom programmable logic controller (PLC) to control key components and independently run QA features (Figure 19).

QA features for the XCEM focus upon the two numbers required to determine stack gas concentration: mass of the metal on the filter and sample volume. Metal mass on the filter is determined in micrograms per spot using the XRF while sample volume is in dry standard cubic meters per spot as determined by mass flow meters. A spot is equal to the area on the filter tape scanned by the XRF analyzer. The XCEM program builds in automated redundancy and daily QA checks for measuring both mass and volume. Acceptable QA boundaries are user-defined. If the measured values fall outside of these boundaries, such as

when instrument drift occurs, the software package will signal an alarm and flag the data. All QA measurements are logged in the XCEM database and are available for use by Microsoft® Excel and Access or compatible data management programs.

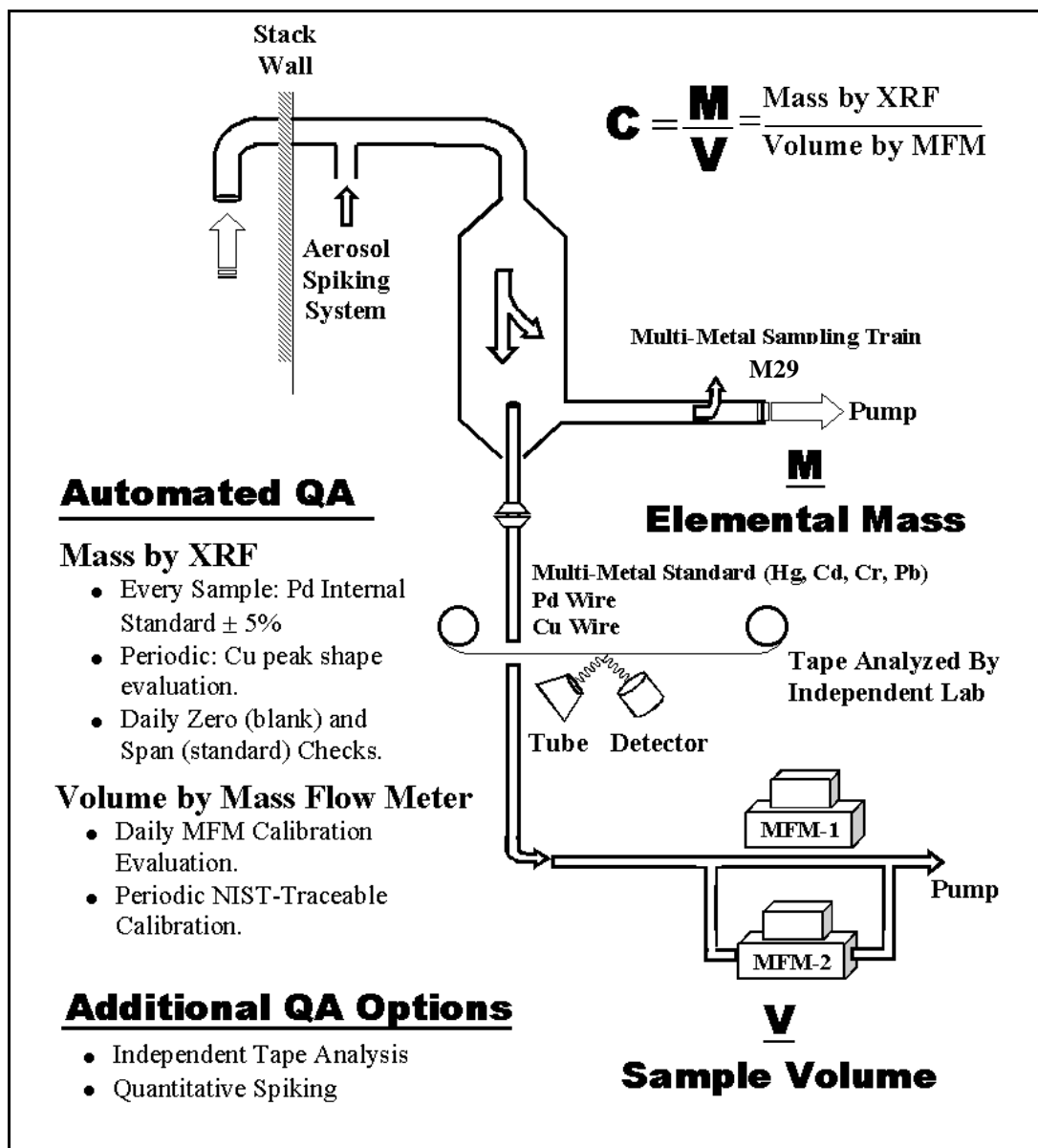

Figure 18. XCEM QA program.



Figure 19. PLC control for the XCEM.

Mass measurement QA

XCEM mass measurements are determined using a KevexSpectrace QuanX XRF. For this project, the XRF analyzer was calibrated using thin film standards made by pipetting a National Institute of Standards and Technology (NIST)-traceable standard solution containing equal masses of silver (Ag), arsenic (As), Cd, Cr, Hg, Pb, and selenium (Se) onto a Mylar film. A series of 10 standards with varying concentrations were analyzed by the XRF, and a linear relationship between x-ray intensity and mass was determined. The XRF is stable over a period of months and typically requires calibration only about once every 6 months.

XRF zero and span tests are conducted examining blank filter tape and a metal rod attached to a pneumatic plunger mounted below the sampling cassette (Figure 20). At a user-defined time of day, the XCEM begins the QA process by advancing clean, unexposed filter tape into the x-ray beam area and analyzing the blank tape as a zero test. Immediately following this test, the plunger extends the multi-metal standard rod into the beam area. The rod, which contains relatively high concentrations of Cr, Hg, Cd, and Pb, acts as a span test. The zero/span test typically takes 20 to 30 minutes.

To check for instrument drift and provide a continuous assurance that the XRF is giving precise, repeatable mass measurements, a Pd wire has been permanently mounted in the XRF x-ray beam analysis region (Figure 21). The Pd is measured with every sample, allowing for continuous comparison to preceding values determined when the instrument was last calibrated.

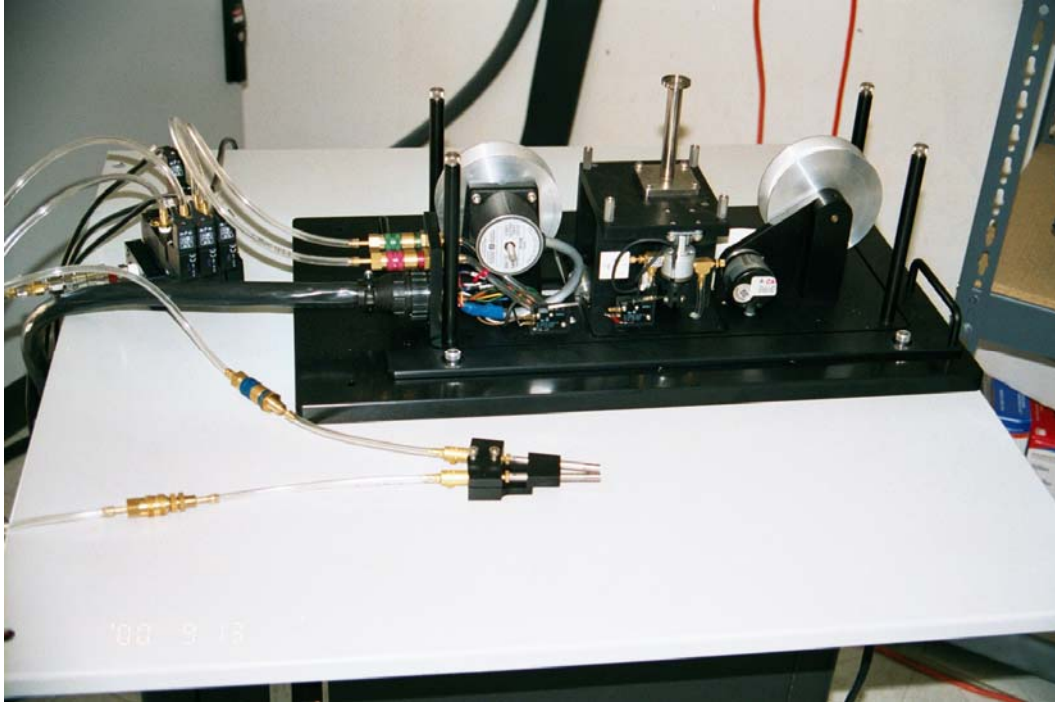

Figure 20. Zero and span test plunger.



Figure 21. Pd wire-mounted for QA.

Flow measurement QA

In addition to mass measurements, the XCEM assures quality flow measurements using a redundant mass flow meter in-line with the existing flow controller. When QA mass measurements are engaged, the software interface diverts flow out of the flow controller and through the second mass flowmeter. The two flow rates are then compared. If a significant difference is determined, an alarm will be posted and the data will be flagged. Having a redundant flow meter provides two additional benefits. It can act as a back-up method for measuring concentrations if the flow controller breaks down, and the QA mass flow meter can be periodically removed and sent out for recalibration without affecting the XCEM normal operations.

Extraction system QA

The accuracy of the extraction system can be evaluated periodically (e.g., every 6 to 12 months) by spiking metals directly into the XCEM. A spiking system was developed that uses a NIST traceable standard solution and a nebulizer. This spiking system, which is inexpensive to operate, demonstrated good precision and was able to spike a variety of metals over a wide concentration range. Using this approach, XCEM-reported metal concentrations can be compared with results from either an M29 sample train or a filter grab sample. The XCEM spiking system and results of M29 comparison tests are discussed later.

Ease-of-use Modifications

In earlier XCEM versions, the sampling platform was permanently mounted to the top of the QuanX XRF. The updated XCEM, however, has been reengineered to include a sampling cassette that is attached with only four thumbscrews to the XRF analysis platform. The sampling cassette is lightweight (about 25 pounds) and can be removed from the analyzer in under 5 minutes (Figure 3). No tools are required to disconnect the electronics' plug, screws, and two pneumatic lines on the cassette. Once removed, the cassette is self-supporting, but a special transport plate is available. It is anticipated that the next version of the XCEM will come with at least two sampling cassettes. Every 2 to 4 weeks, when the XCEM filter tape has been fully exposed, operators will be able to rapidly change sampling cassettes and transport the cassette containing the exposed tape to a separate work area. In the work area, technicians will be able to change filter tapes in a clean environment and conduct routine preventative maintenance on the cassette. It is anticipated that a technician would be able to carry out these tasks in under an hour.

Safety Modifications

The portable sampling cassette contains a mounted filter tape, a stepper motor, pneumatic plungers, lead shielding, and a tape breakage sensor (Figures 3, 20, and 22). The cassette cover is positioned to trigger interlocks so that sampling cannot take place unless the covers and shielding are properly positioned.

In addition to increased efficiency in exchanging filter tapes, the portable cassette ensures that the tape is not contaminated prior to installation into the unit. Another benefit is the system redundancy provided by the cassette. If the stepper motor, plungers, or tape are damaged, the XCEM operator can rapidly exchange cassettes and ensure monitor uptime.

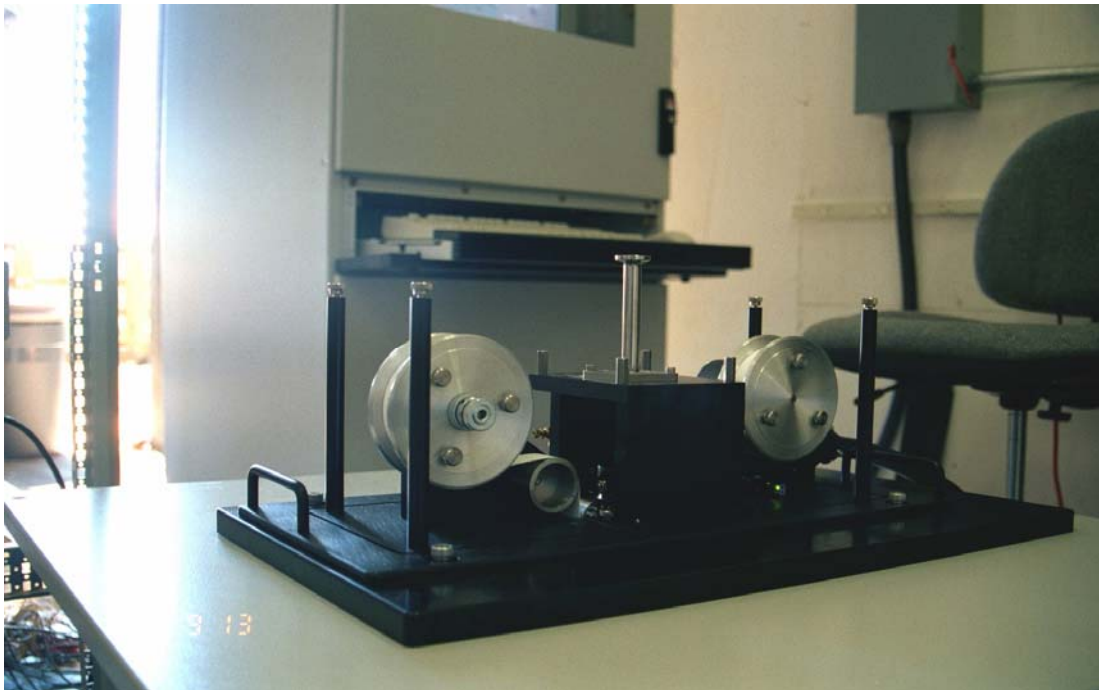

Figure 22. XCEM sampling cassette and XRF control panel.

3 Laboratory Testing

This chapter addresses the last two recommendations that were presented in the MSE-TA report (Bryson et al. 2000): Hg sampling and the spike injection system. As discussed in the previous chapter, additional laboratory testing was needed to evaluate and optimize the Hg capture efficiency of the automated oxidation system, and to compare XCEM mercury measurements with M29. A spike injection system was developed so that M29 comparison tests with six metals in addition to Hg could be performed in the laboratory. This chapter also presents the results of these M29 comparison tests.

Mercury Sampling

Experimental

Optimization of the XCEM Hg sampling efficiency was accomplished in two phases. In the first phase (Figure 23), elemental Hg was generated using a Hg permeation tube in a controlled temperature environment. The elemental Hg vapor was then converted to mercuric chloride using chlorine gas. The resulting mercuric chloride was then captured on a 47-mm diameter RIF that was backed up by a second 47-mm diameter RIF. Any Hg vapor that was not trapped by the RIFs was captured with a carbon-impregnated filter (CIF). Analysis of the relative concentrations on the two RIFs and CIF were conducted to determine if breakthrough was occurring. In the second phase, Hg was generated using the XCEM nebulization system and a stock multi-element standard from VHG Labs, Inc. (Manchester, NH). The Hg was injected directly into the XCEM sampling system and analyzed in real time. The XCEM real-time data were compared to results from a modified EPA M29 sampling train.

Mercury RIF Results

The primary purpose of first-phase Hg testing was to determine RIF vapor phase Hg capture efficiencies under varying flow, temperature, and oxidant conditions. Figure 24 shows a typical capture efficiency curve when flow rates varied. In this series of tests, conducted with a filter temperature of 140 °F (60 °C), the primary RIF collected greater than 90 percent of the Hg when flow rates through

the filter were less than 0.8 dry standard Lpm/cm² (liters per minute per square centimeter). These results indicate that the RIF could capture greater than 90 percent of vapor phase (elemental) Hg under typical operating conditions.

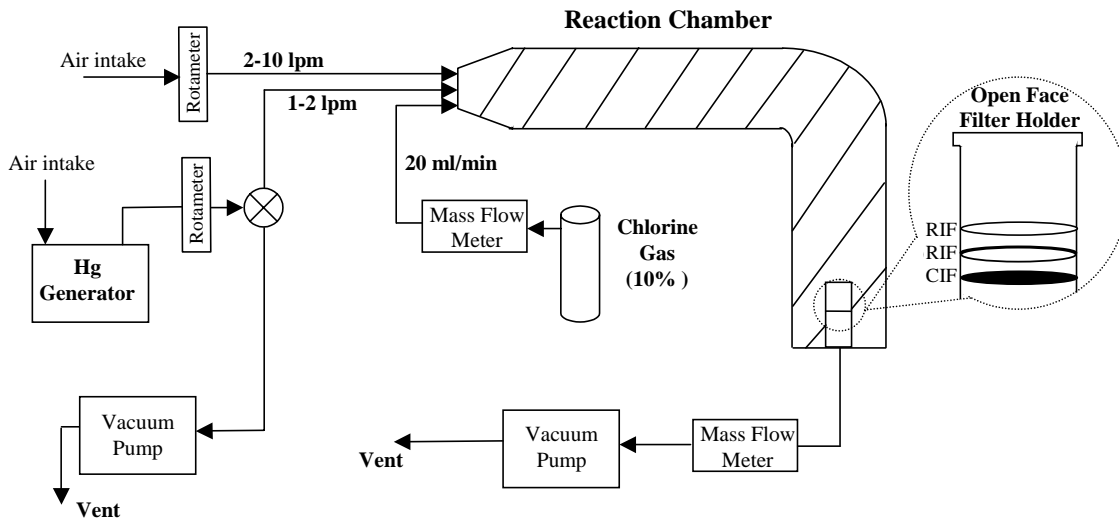

Figure 23. Schematic of Hg capture for first phase experiments.

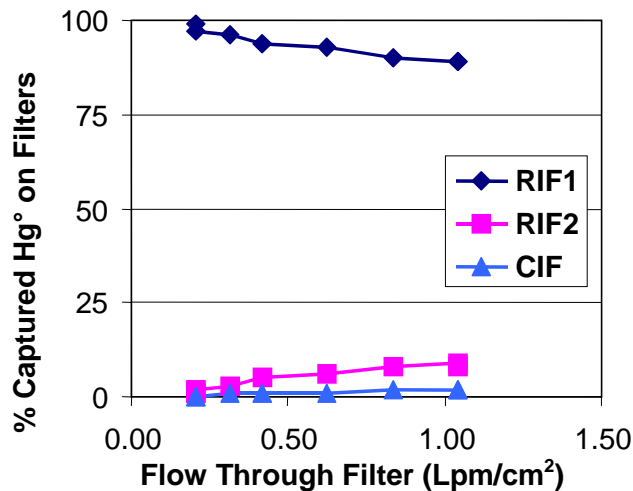

Figure 24. RIF Hg capture efficiency versus air flow rate through filter.

Mercury Oxidation Automation

The XCEM continuously extracts a small subsample, on the order of 0.5 Lpm, of stack gas from the stilling chamber. Prior to collection on the RIF, this subsample enters a dilution/oxidation chamber where an oxidizing agent, such as chlorine gas, is used to convert the elemental Hg to ionic phase Hg, which can then be captured on the RIF. The calculations that determine the settings for the oxidant valve, flowmeter, and dilution have all been automated and are fully integrated into the XCEM computer control system.

Mercury XCEM Results

During the second phase of Hg testing, the XCEM total Hg measurement capability was determined using an M29 sampling train. Mercuric nitrate and other metallic compounds of interest were spiked into the XCEM extraction system and were simultaneously collected by the RIF and an M29 sampling train. Four M29 tests were conducted, with each test lasting 3 hours. Since the XCEM determined Hg concentrations every 12 minutes, a time-weighted average was used to compare XCEM and M29 results.

Overall the XCEM and M29 Hg concentrations were in good agreement. The average XCEM Hg concentration was $135 \pm 8 \mu\text{g}/\text{m}^3$ (micrograms per cubic meter) while the average M29 result was $122 \pm 6 \mu\text{g}/\text{m}^3$. On average, an 11 percent difference existed between reported sampling run concentrations, which is within M29 uncertainty. No indication of filter trapping inefficiencies was evident because the XCEM reported slightly higher Hg concentrations than M29. During testing, about 7 percent of the Hg was in the vapor phase as defined by the M29 front half/back half measurement.

The XCEM/M29 Hg RA for the four test runs was 20.4 percent, which when rounded to two significant digits marginally meets the PS-10 RA criterion. This number was calculated using the method described in PS-10. The RA will decrease with increased numbers of runs, so that it is estimated that the RA would decrease to about 18 percent if more runs with similar results had been conducted.

Overall the M29 results demonstrate that the XCEM can adequately trap and measure Hg concentrations under realistic test conditions.

Method 29 Comparison Tests

Spike Injection System

Approach

The quality of the XCEM mass measurements is routinely evaluated with the Pd quality control standard, zero, and span checks. However, a spiking system is required to confirm XCEM transport and collection efficiencies. An ideal spike injection system should have the following capabilities:

- Can inject all MACT metals at levels well above detection limits
- Repeatable precision

- Easy and safe to implement
- Relatively inexpensive to operate
- Able to produce an aerosol with high transmission efficiency
- Quantifiable.

Several options were reviewed which could potentially meet the above criteria (Table 2). These options included:

- **Nebulization.** A solution containing elements of interest is aspirated into a gas stream. The resulting droplets dry and create an aerosol of salt particles.
- **Aerosolization.** A spiked powder is suspended in a carrier gas that is injected into the stack gas stream. Methods of aerosolizing a spiked powder include moving a deposit under a gas jet, fluidized bed plus elutriator, or micro-screw injection.
- **Evaporation.** A compound of a spiking element with a well-defined boiling point is raised to a temperature above its boiling point. This takes place in an inert carrier gas that is introduced into the stack gas.
- **Combustion/aspiration.** A solid or liquid containing spiking elements is burned in a carrier gas. The combustion products containing the spiking elements are carried into the stack gas with the carrier gas. Oils containing a variety of elements are available and could be readily burned. Solids would need to be specially prepared and there would be a greater tendency for the elements to remain in the ash.
- **Electric spark.** A high voltage spark or arc is created between two carbon electrodes containing spiking elements. The sparking process generates fine particles with the spiked elements.
- **Hydride generation.** An inert gas is bubbled through a solution containing the spiking elements. Sodium tetraborohydrate is added to the solution. The hydride-forming elements are exchanged with the carrier gas and carried to the stack.
- **Specialty gas.** A commercially prepared and certified gaseous mixture containing the required spiking elements.

After reviewing the options, nebulization was selected as the preferred alternative due to its simplicity, potential for extended operation, and quantification advantages. Nebulizers have been used to successfully generate aerosols for a number of years (Ylatalo et al. 2000; Flagan and Seinfeld 1988; Fuchs and Stutugin 1966). They are relatively inexpensive and easy to use. In addition, NIST traceable laboratory standards are available for all metals of interest. These standards are available in a wide variety of concentrations (From 1 to 2000 µg/mL) and have a guaranteed shelf life of 1 year.

Table 2. Evaluation of spike injection options.

Option	Advantages	Disadvantages
1) Nebulization	Ease of use Low cost Readily available standards	Humidity affects nebulization rate Potential water super-saturation in stack sample
2) Aerosolization	Ease of use Low cost	Uniformity of powder issues Potential agglomeration issues Quantification is difficult
3) Evaporation	Ease of use Low cost	Loss of large particles to walls Different temperatures required for different elements
4) Combustion/ Aspiration	Ease of use Low cost Readily available standards Carrier particles produced by the combustion process	Potential safety issues
5) Electric Spark	Precision Ease of use	Potential safety issues Engineering expense Quantification difficulties
6) Hydride Generation	Ease of use Low cost	Cost of components Instability of hydrides Not all metals are available
7) Specialty Gas	Independent certification	Cost of gas Availability of gas

Design

During nebulization, compressed air is pushed into the bottom of a nebulizer cup containing a liquid solution. The compressed air exits the cup at the top and creates a partial vacuum, which draws liquids out with the air. A DeVilbiss nebulizer (Illinois Tool Works, Glendale Heights, IL) was used for these tests. The nebulizer included an impaction plate designed to prevent large droplets from escaping.

For the M29 testing, the nebulization system produced 100 liters per minute (Lpm) of spiked gas with concentrations between 115 and 180 $\mu\text{g}/\text{m}^3$ for seven metals: Ag, As, Cd, Cr, Hg, Pb, and Se. A commercially available solution standard (VHG Labs, Manchester, NH) was used to spike the gas stream. The standard solution contained 100 $\mu\text{g}/\text{mL}$ of each metal in 5 percent nitric acid. For each test run, standard solution was added to the nebulizer cup, which was then weighed. Following nebulization, the cup was reweighed and the amount of nebulized solution was determined.

About 5 Lpm of spiked aerosol from the nebulizer cup was injected into a vertical four-inch diameter pipe. Another 95 Lpm of dry air was drawn into the pipe with the spiked aerosol. The pipe, which was 3-ft long, was heat traced and kept at about 220 °F (103 °C). The addition of heat and dry air served to rapidly dry

the nebulized particles. It is estimated that the typical dried particle size was on the order of 0.2 microns in diameter once it exited the 4-inch tubing. The combined 100 Lpm of spiked gas was then drawn into the stilling chamber for extraction by the XCEM and M29 probes.

Spiking evaluation

The DeVilbiss nebulizer showed good precision over the 4 days of M29 testing. The overall nebulization rate, as determined by mass measurements, was 0.23 ± 0.01 mL/min. This represents a 4 percent relative standard deviation (RSD). Following M29 testing, further nebulization tests under more controlled conditions have demonstrated improved precision and an RSD of less than 1 percent.

Although the nebulizer precision was good during M29 testing, the mass of nebulized solution could not be used to accurately predict stack concentrations.

Despite the overall quantification issue, nebulization remains a promising approach. The current nebulization system is able to precisely provide all elements of interest over a wide range of concentrations allowing for an effective XCEM test range of 1–2000 $\mu\text{g}/\text{m}^3$. It is relatively inexpensive, safe, and easy to operate, and a wide variety of metals are available as NIST traceable standard solutions.

Test Design

To test XCEM accuracy, four modified M29 test runs were conducted from 4–7 November 2000. During these tests, simultaneous samples were collected by the XCEM and an M29 sampling train. Simulated “stack gas” was provided by nebulization of a metals solution containing equal concentrations of As, Cd, Cr, Hg, Pb, Se, and Ag. The M29 sample probe extracted the stack gas from a 2-inch-diameter pipe located approximately 3 feet downstream of the XCEM extraction tube. Both sampling sites were at least eight diameters downstream and two diameters upstream of any flow disturbance as required by EPA sampling protocols. During testing, XCEM and M29 temperatures, flows, and pressures were held constant. No XCEM dryer was used for the M29 tests since water content was determined to be less than 1 percent of the volume. Test parameters are listed in Table 3.

The M29 sample was collected isokinetically while the XCEM extracted subsokinetically from the stilling chamber. The stilling chamber design slows stack gas and allows for non-isokinetic sampling due to its low Stoke’s number (Cooper et al. 2000).

Table 3. Test conditions during M29 sampling.

Test Parameter		Test Parameter	
Main Line Flow (scfm)	3.52 ± 0.02	Stillling Chamber Temperature	~ 230 °F
XCEM Sample Flow (sLpm)	0.58 ± 0.003	Temperature at M29 Impinger Inlet	~ 230 °F
M29 Flow (sLpm)	4.1 ± 0.2	Temperature at M29 Impinger Outlet	< 52 °F
Nebulization Rate (mL/min)	0.23 ± 0.01	M29 Sample Time (min)	180
Nebulizer Metal Concentration (µg/mL)	100	Ambient Relative Humidity	40 - 60%
Nebulized Metals	As, Cd, Cr, Hg, Pb, Se, Ag	Ambient Temperature	55 - 65 °F

Metals were nebulized using the XCEM spike injection system. The nebulized standard solution, provided by VHG labs, is NIST traceable and contains 100 µg/mL of each metal in 5 percent nitric acid. Particle size for the test was estimated to be on the order of 1 micron or less. During the M29 tests, the nebulization rate was very stable and varied by no more than 5 percent.

The XCEM exhibited no mechanical or functional problems during the 4-day test period, which included over 150 test runs.

XCEM Results During Method 29 Testing

XCEM results by element

The XCEM reported metal concentrations in µg/m³ every 11.7 minutes for each of the nebulized metals (Figure 25). Every 2 to 3 hours, spiking was stopped to refill the nebulizer cup. Since the refilling process took about 5 minutes, it reduced concentrations for one XCEM sample run. These concentration changes are shown as deflections in Figure 25 and illustrate the sensitivity of the instrument to changes in metal concentration. The horizontal magenta lines indicate the respective metal M29 concentration for the duration of each M29 sample.

To evaluate the XCEM instrument stability, a Pd rod is situated directly above the x-ray tube and provides Pd concentrations with every sample. For these tests, the Pd QA rod had an effective concentration of 140 ± 1.0 µg during the 4-day test period with a precision of better than 1 percent (Figure 25). The consistent Pd concentrations during M29 testing indicate that no XRF instrument drift occurred.

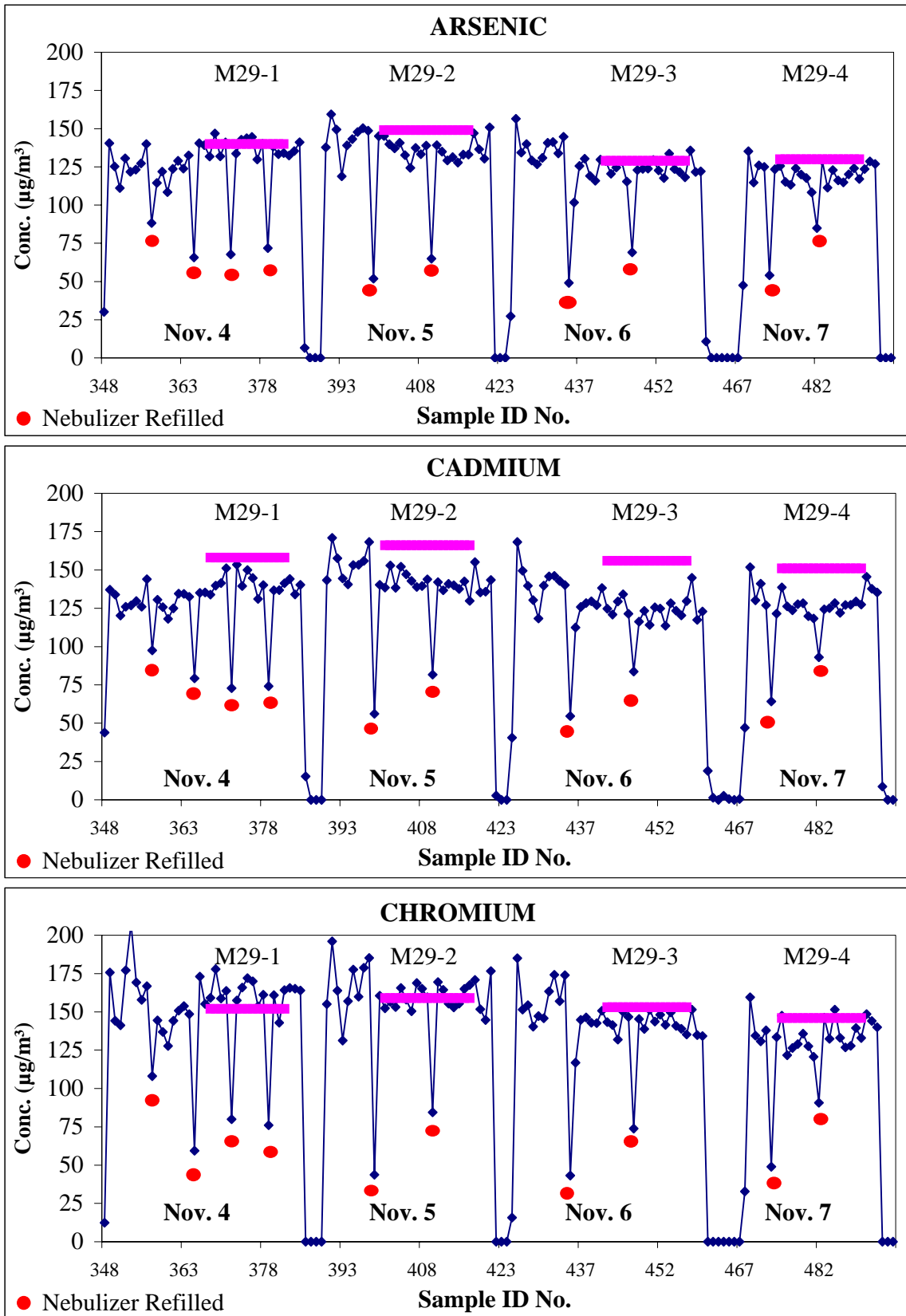

Figure 25. XCEM elemental concentrations during M29 testing.

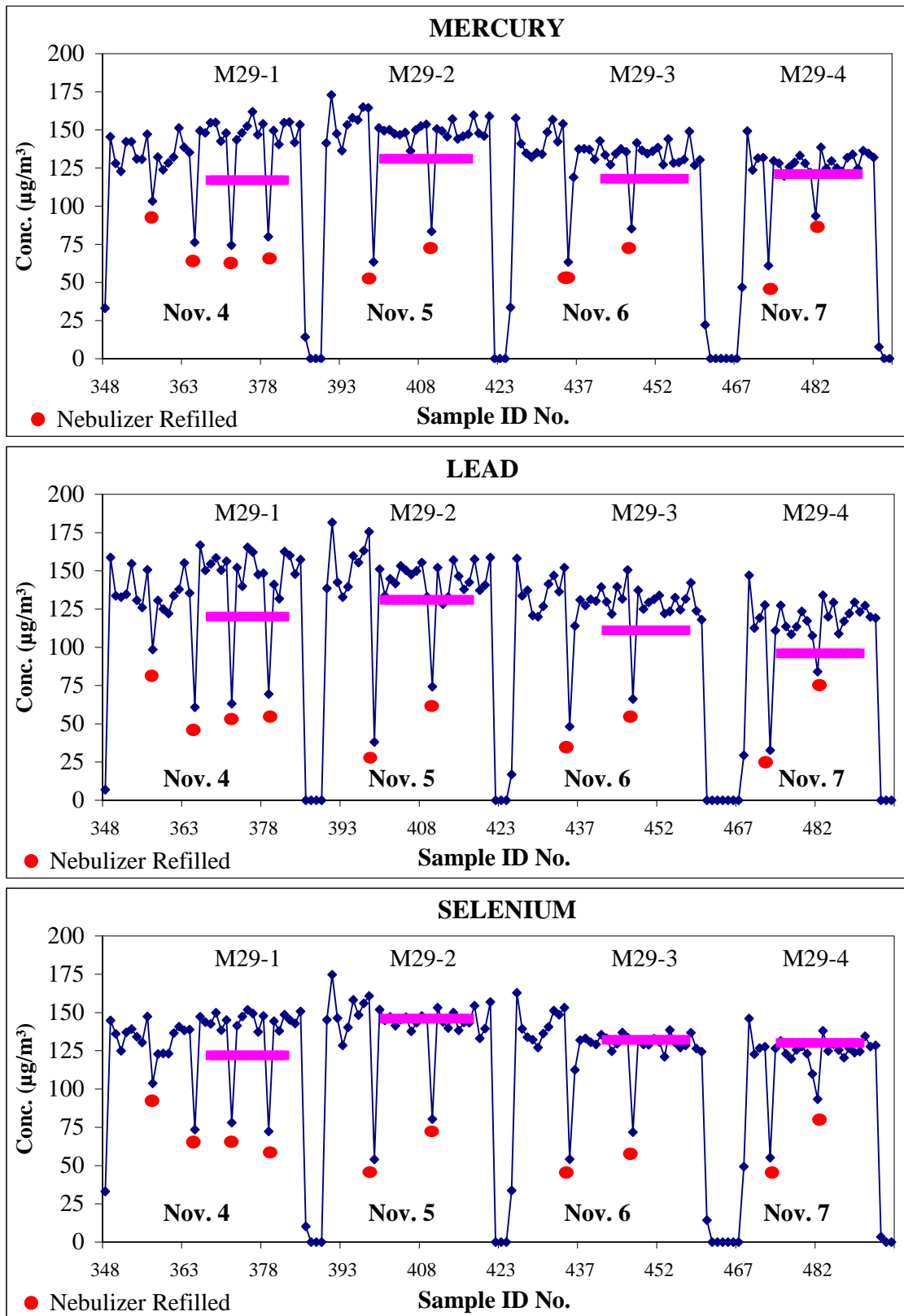

Figure 23 (Cont'd). XCEM elemental concentrations during M29 testing.

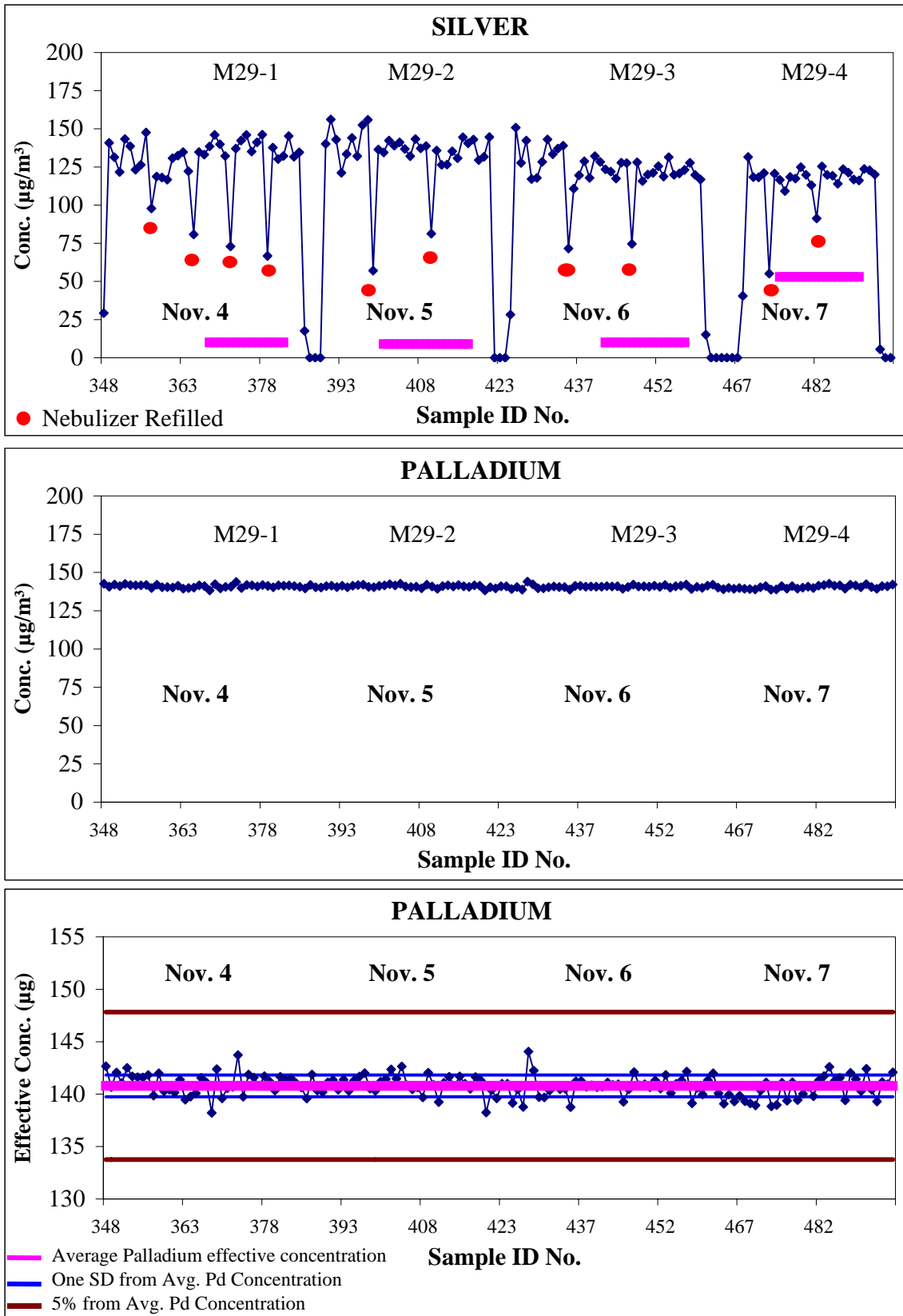

Figure 23 (Cont'd). XCEM elemental concentrations during M29 testing.

XCEM metal concentrations during the 4 days of testing were highly correlated. For example, in comparison to Cd, all of the metals exhibited a correlation of 0.95 or better and had a slope between 0.95 and 1.17 (Figure 26). The choice of Cd was purely arbitrary, and similar relationships would be seen if another metal was chosen. The slope is expected to be close to 1 because all the metals were spiked with the same concentration. Differences in correlation are expected to be due primarily to XRF calibration and spectral measurement uncertainties. The high degree of correlation and relatively uniform slope indicate good uniformity in the relative concentration of the spiked stack gas.

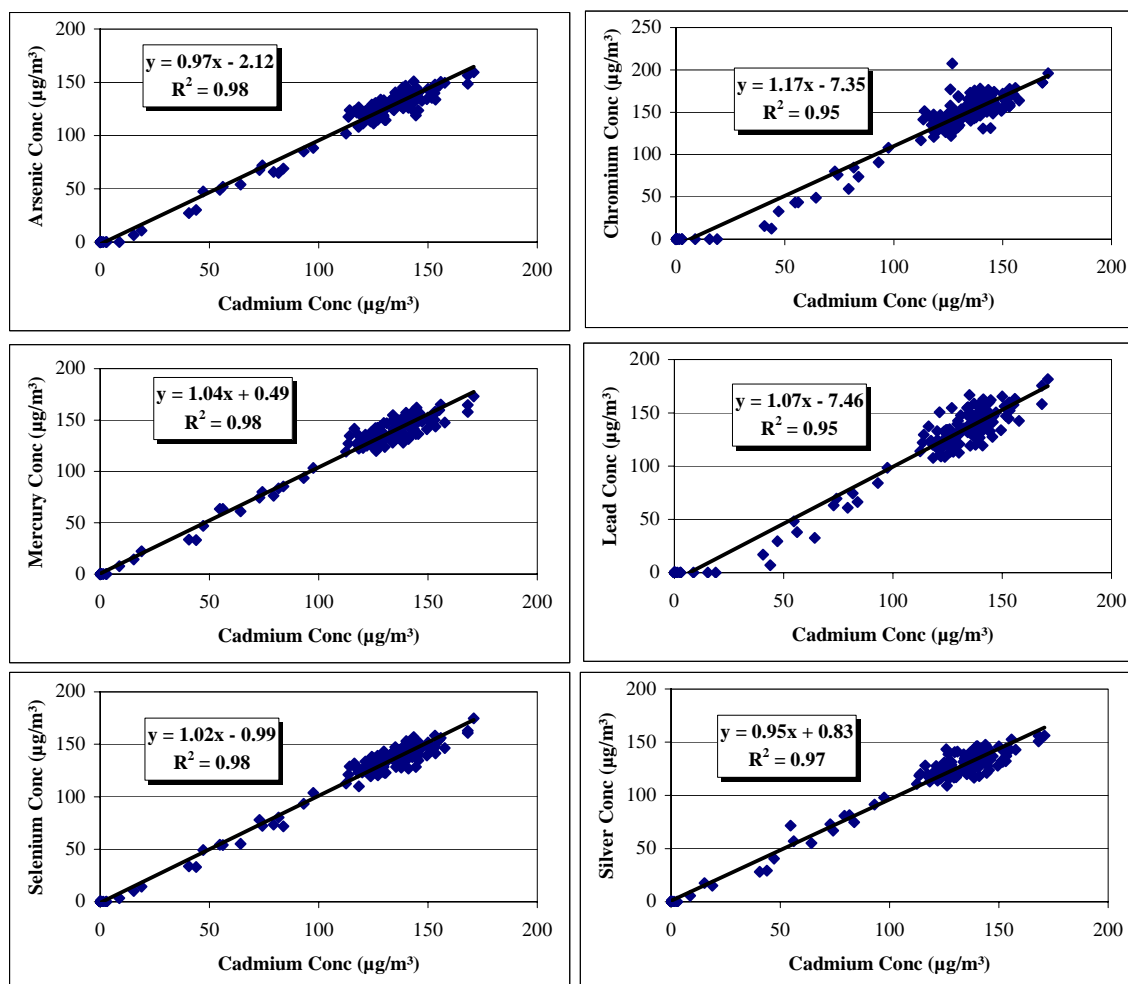

Figure 26. XCEM cadmium versus other spiked metals during M29 testing.

Pre- and post-tests at XCEM Port versus Method 29 port

QA testing was conducted before and after each of the four M29 test runs. During QA testing, an open-faced filter holder containing an RIF and CIF was used to collect a grab sample from the M29 port. This filter combination, developed by CES, is called a Hazardous Elemental Sampling Train (HEST), and has been tested in a variety of stack environments as a way of quickly evaluating stack gas metal concentrations (Johnson et al. 1998). The HEST samples were analyzed using a laboratory XRF and compared to the XCEM reported concentrations for the concurrent run. Results for the pre- and post-tests are shown in Table 4. Overall, the XCEM reported average metal concentration was $138 \pm 13 \mu\text{g}/\text{m}^3$ while the M29 port test average concentration was $126 \pm 12 \mu\text{g}/\text{m}^3$ (including Ag). Comparing the average metal concentration is important because all metals were spiked at identical concentrations. Especially useful is comparing the average concentrations for all metals during one sampling event (e.g., run 2 pre-test or run 3 post-test). It appears that the averages are within the standard deviation between the two ports and that the deviations are similar. Using the M29 port results as the “true” value, the XCEM reported concentrations fell within the 20 percent RA criterion in PS-10 for all metals except Ag (Table 5). These calculations were performed using the eight sets of sample values for each metal. The M29 port concentration for Ag was low by 17 percent relative to all other reported metal concentrations, while the XCEM Ag concentration was in good agreement with reported concentrations for other spiked metals.

Table 4. Elemental concentrations at XCEM and M29 Ports during pre- and post-tests.

TEST	As		Cd		Cr		Hg		Pb		Se		Ag		XCEM (No Ag)			M29 (No Ag)			
	XC	M29 Port	XC	M29 Port	XC	M29 Port	XC	M29 Port	XC	M29 Port	XC	M29 Port	XC	M29 Port	Avg	SD	% RSD	Avg	SD	% RSD	
1	PRE	115	110	122	110	132	114	126	123	115	123	110	117	96	124	6	5	114	5	5	
	POST	138	146	137	147	165	152	148	166	153	150	147	147	133	126	148	10	7	151	8	5
2	PRE	141	138	147	140	167	143	156	154	150	142	149	138	139	115	152	9	6	143	6	4
	POST	133	141	136	148	148	146	147	163	139	145	136	143	131	117	140	6	4	148	8	5
3	PRE	128	109	124	115	144	118	134	125	117	130	113	117	87	130	8	6	116	5	5	
	POST	122	118	120	119	135	123	129	133	121	122	125	119	118	95	125	6	4	123	5	4
4	PRE	120	120	136	122	133	124	128	135	116	122	125	121	118	95	126	7	6	124	6	5
	POST	128	116	137	116	142	122	133	133	120	122	128	118	121	90	131	8	6	121	6	5
AVERAGE		128	125	132	127	146	130	137	142	130	129	133	126	124	103	134	6	5	130	6	5

Table 5. Relative accuracies of M29 Port versus XCEM Port during pre- and post-tests.

Element	RA	Meets EPA-Proposed Criterion ¹
Arsenic	8.8	Yes
Cadmium	11.3	Yes
Chromium	17.0	Yes
Mercury	8.3	Yes
Lead	4.4	Yes
Selenium	10.5	Yes
Silver	27.6	No

¹ EPA-proposed PS-10 for Multi-Metal CEMs requires an RA Criterion of 20%.

XCEM vs M29

XCEM and M29 analytical data

During M29 testing, the XCEM reported stack gas concentrations for As, Cd, Cr, Hg, Pb, and Se in $\mu\text{g}/\text{m}^3$. In addition to an electronic copy, the XCEM printed a hard copy of the results after each test run. Metals concentrations used in this report are the same as the XCEM hardcopy output with the exception of corrections to As and Hg concentrations. After testing and before receiving the M29 results, the XRF was recalibrated using a duplicate/new set of calibration standards. At that time, it was determined that the original standards' Hg concentrations were too low by 17 percent, giving a reported concentration that was too high. As such, the XCEM-reported Hg concentrations were reduced by 17 percent.

Except for Hg, all of the elements were in good agreement following calibration. During recalibration, however, it was discovered that a 10 percent As correction factor, which had been used in the shakedown period, had accidentally been left in the XRF calibration equation. All XCEM concentrations used in this report were determined without the use of correction factors. Accordingly, the XCEM-reported As concentrations were reduced by 10 percent.

After making these corrections, CES received the M29 data from an independent laboratory, Chester LabNet. Included with the M29 data were results from blank and spike tests. No changes were made to M29 laboratory results with the exception of a blank subtraction to account for Se in the M29 blank.

XCEM vs M29 test results

XCEM and M29 concentrations for the four M29 test runs are shown in Table 6. Reported concentrations for the two methods are in good agreement for all elements except Ag.

No apparent overall bias is evident between the two methods. Indeed, the overall average non-Ag metal concentrations reported by the two methods are within a few percent of each other. This trend holds true for each sample run (Table 7) and indicates that it is probable that no particulate loss occurred in the sampling system.

Table 6. Reported XCEM and M29 concentrations.

Element	Method	Concentration					Avg. %
		Run 1	Run 2	Run 3	Run 4	Average	Diff.
As	XCEM	128	131	120	117	124	10
	M29	140	149	129	130	137	
Cd	XCEM	131	138	121	124	129	19
	M29	158	166	156	151	158	
Cr	XCEM	149	156	139	131	144	6
	M29	152	159	153	146	152	
Hg	XCEM	139	145	131	126	135	-11
	M29	117	131	118	121	122	
Pb	XCEM	139	140	127	117	131	-15
	M29	120	131	111	96	114	
Se	XCEM	134	141	127	123	131	1
	M29	122	146	132	130	132	
Ag	XCEM	128	133	120	117	125	-951
	M29	10	9	10	53	21	
XCEM (No Ag)	Avg	137	142	127	123	132	4
	SD	8	8	7	5	7	
	% RSD	6	6	5	4	5	
M29 (No Ag)	Avg	135	147	133	129	136	
	SD	18	14	18	20	17	
	% RSD	13	10	14	15	13	

Table 7. Average metal concentrations for each sampling run.

M29 Run No.	XCEM Avg. Metal Conc. ($\mu\text{g}/\text{m}^3$)	M29 Avg. Metal Conc. ($\mu\text{g}/\text{m}^3$)	Percent Difference
Run 1	137	135	1.5
Run 2	142	147	3.4
Run 3	127	133	4.5
Run 4	123	129	4.6
Average	132	136	3.5

¹ Metal concentrations are an average of As, Cd, Cr, Hg, Pb, and Se for each run.

The strong average concentration correlation is reflected in the positive RA results (Table 8). Even with only four sampling runs, the RA for As, Cr, Hg, and Se meets the PS-10 RA criterion of 20 percent. During formal M29 certification, a minimum of nine runs is recommended by EPA's proposed PS-10. Had the XCEM been tested for nine runs, it is estimated (by using a value of nine for the number of sample runs in the PS-10 RA calculation) that Pb would have also met the RA criterion. The only MACT metal that would not meet the RA criterion was Cd with an RA of 23 percent. Since M29 Cd concentrations were, on average, 15 percent higher than other M29 reported concentrations, it is believed that differences in the Cd concentration are a function of a high M29 bias as discussed in the next section.

Table 8. XCEM and M29 relative accuracies.

Element	RA with Four M29 Runs	Est. RA with Nine M29 Runs
Arsenic	14.3	13.0
Cadmium	22.7	21.6
Chromium	13.1	11.0
Mercury	20.4	17.8
Lead	21.3	19.3
Selenium	16.2	13.2
Silver	721.7	662.6

In contrast to the other spiked metals, Ag XCEM and M29 concentrations do not show good agreement. The average Ag concentration during M29 testing was reported as $21 \pm 21 \mu\text{g}/\text{m}^3$, while the XCEM Ag concentrations during the four runs was $131 \pm 8 \mu\text{g}/\text{m}^3$. This M29 average Ag concentration is more than five standard deviations from the average M29 non-Ag concentration of 136 ± 18 . Although the pre- and post-test results did indicate some potential difference in the Ag concentrations, the average reported M29 port concentration of $103 \pm 15 \mu\text{g}/\text{m}^3$ was still five-fold higher than the M29 test run results. The laboratory that performed the M29 analysis believes some analytical problems were possible for Ag and cites the fact that Ag and Sb are the only elements exempted from spike recovery criteria by the standard method. For these reasons (and since the Ag spike did not meet the 80 to 120 percent recovery criterion), it is believed that the M29 Ag numbers were inaccurate.

The consistency between the overall average XCEM and M29 concentrations is important because it indicates that particle loss did not occur during testing. The consistency in the elemental concentrations also indicates that elemental fractionation was not occurring. Except for Ag, all 24 reported metal concentrations during each of the test runs were within the combined 5 percent XCEM and 13 percent M29 uncertainties (Figure 27).

Method 29 and XCEM Precision and Accuracy

As discussed in the last section, no indication of particle loss or chemical fractionation was observed by either method during M29 testing. As such, all elements should have been present in equal concentrations at both the XCEM and M29 ports. In this situation, a hypothetical unbiased method's reporting of elemental concentrations for a given sample run would be randomly distributed above and below the "true" elemental concentration. The average elemental concentration would then be a method's best estimate of the "true" concentration in the stack, and the range of distributions around and about the average

concentration would reflect the method's precision. Elemental concentrations consistently and significantly above or below the average concentration would indicate measurement problems. Figure 28 shows elemental concentrations for each sample run that have been normalized to the average elemental concentration. Normalized concentrations in Figure 28 were calculated using Equations 1 and 2.

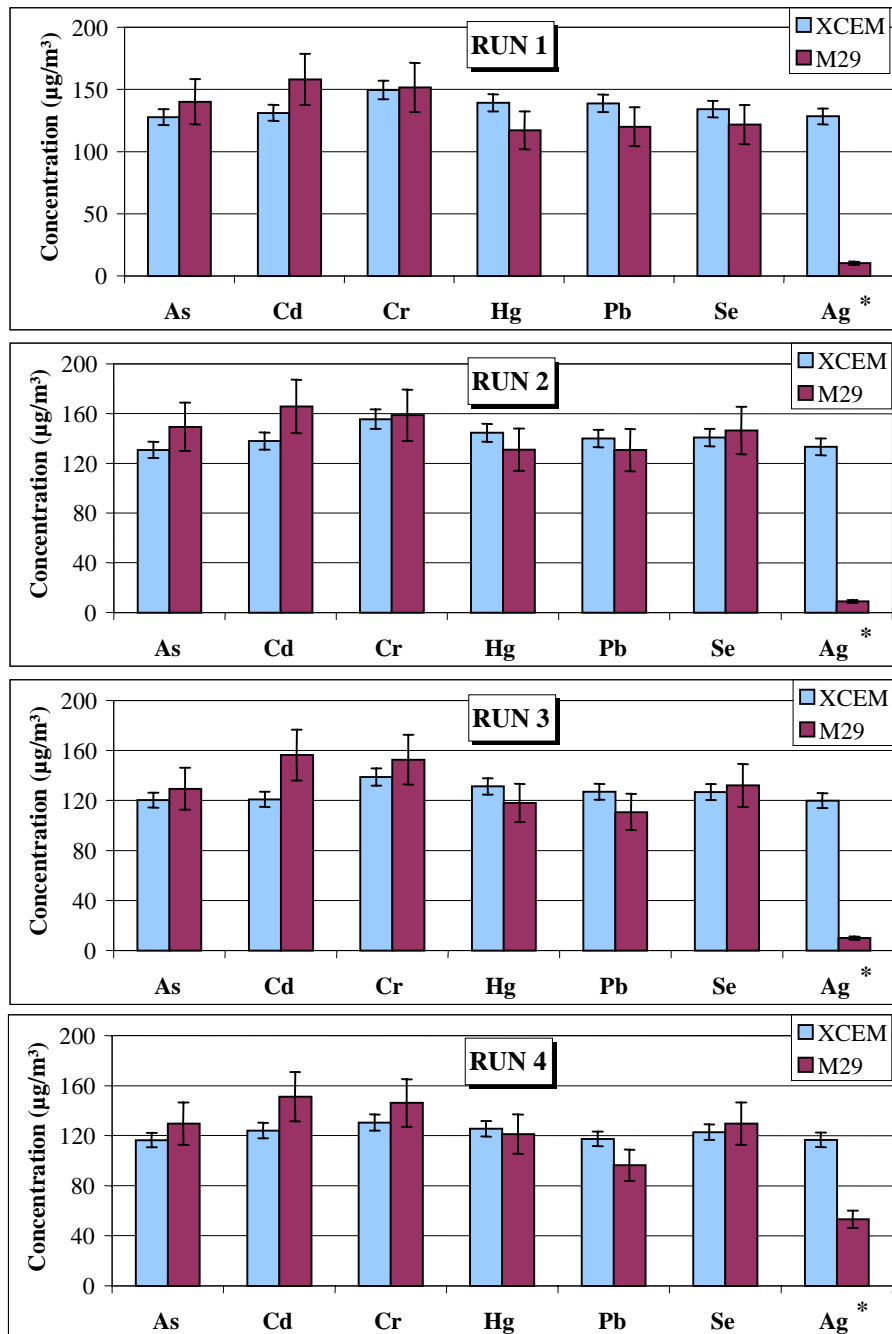

* Expected concentration of all elements should be the same.

Figure 27. Comparisons of XCEM and M29 concentration by run.

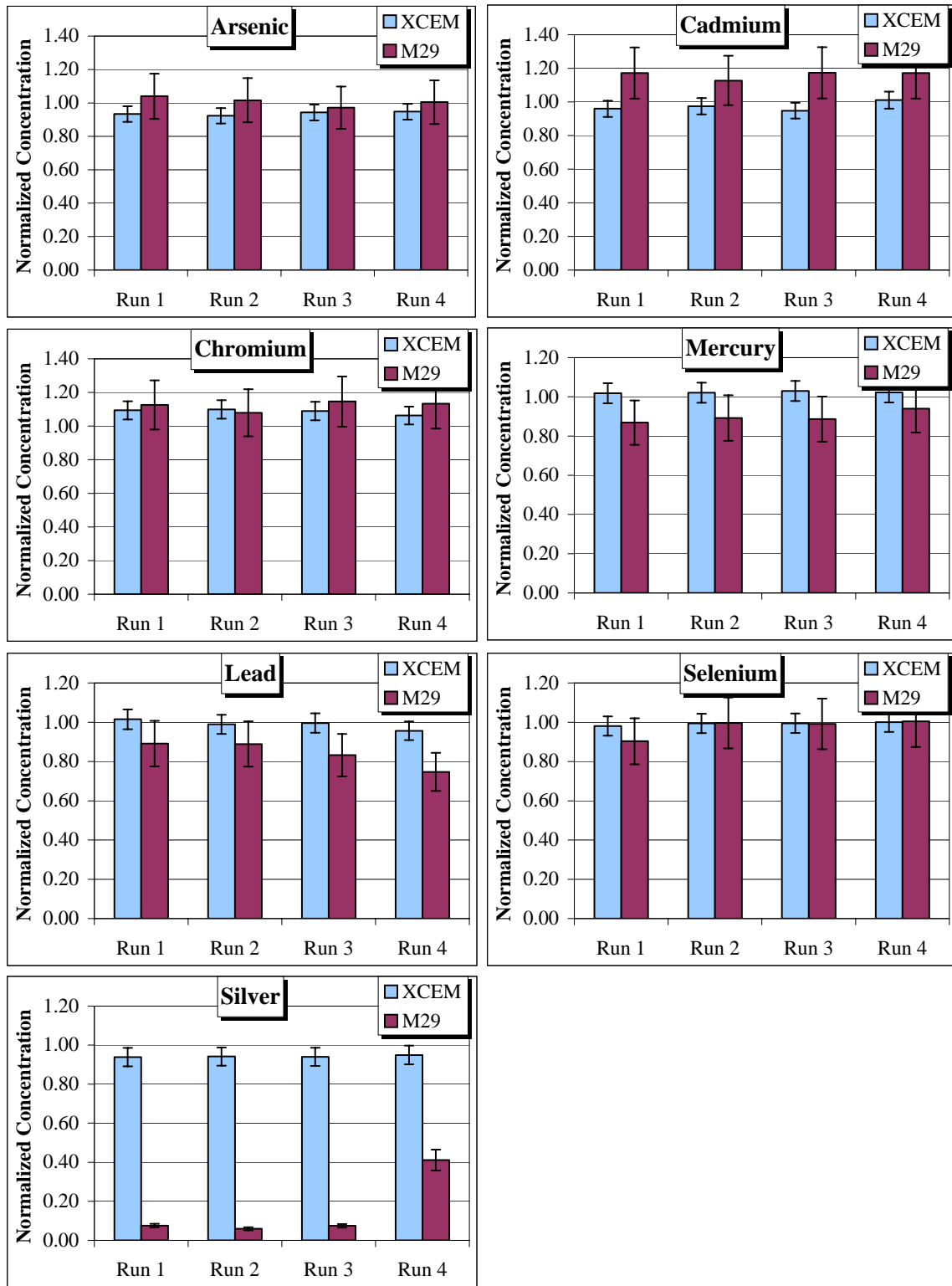

Figure 28. XCEM and M29 normalized concentrations by element.

$$X_n = \frac{X_e}{\bar{X}} \quad \text{[Eq 1]}$$

where,

X_n = Normalized XCEM concentration for an element during a sampling run
 X_e = Reported XCEM concentration for an element during a sampling run
 \bar{X} = Average of reported XCEM As, Cd, Cr, Hg, Pb, and Se concentrations during a sampling run

$$M_n = \frac{M_e}{\bar{M}} \quad \text{[Eq 2]}$$

where,

M_n = Normalized M29 concentration for an element during a sampling run
 M_e = Reported M29 concentration for an element during a sampling run
 \bar{M} = Average of reported M29 As, Cd, Cr, Hg, Pb, and Se concentrations during a sampling run.

In Figure 28, all XCEM normalized concentrations are within 10 percent of the average elemental concentration, and two-thirds of the values are within 5 percent of the average elemental concentration. This is consistent with an XCEM estimated one-sigma uncertainty of 5 percent. For the M29 samples, however, only As and Se have all reported concentrations within 10 percent of the average M29 elemental concentration. Two-thirds of the M29 values are within 13 percent of the M29 average, which is consistent with a M29 one-sigma precision of 13 percent. Interestingly, M29 Cd and M29 Pb concentrations have the greatest deviation from the M29 average, 16 percent high and 16 percent low, respectively, and are the two elements with the highest RAs relative to the XCEM. The M29 Cd is, on average, 19 percent higher than the XCEM, and the M29 Hg is, on average, 11 percent lower. This indicates that much of the RA difference between the XCEM and M29 for Cd and Pb may be a product of M29 bias.

Overall, the normalized concentrations indicated one-sigma uncertainties of about 5 percent for the XCEM and 13 percent for the M29. This M29 uncertainty is in good agreement with the EPA uncertainty estimate of 10 to 15 percent (MACT 1999b). The M29 normalized concentrations showed significant inter-elemental differences indicating a possible method bias, which could be responsible for RA differences.

4 Field-ready XCEM

CES constructed a new XCEM for testing at the TEAD facility. This prototype incorporates all the changes described in the previous chapters. It also includes a modified ThermoNoran QuanX energy dispersive XRF analyzer (Thermo KeveX) for metal detection. The QuanX is capable of simultaneously measuring 19 elements and a Pd QA standard. In addition, an eductor downstream of the stilling chamber is used to pull the stack gas through the extraction system. This change is indicated in the slightly modified main component screen of the custom WonderWare® (Progressive Software, Albany, OR) software interface (Figure 29).

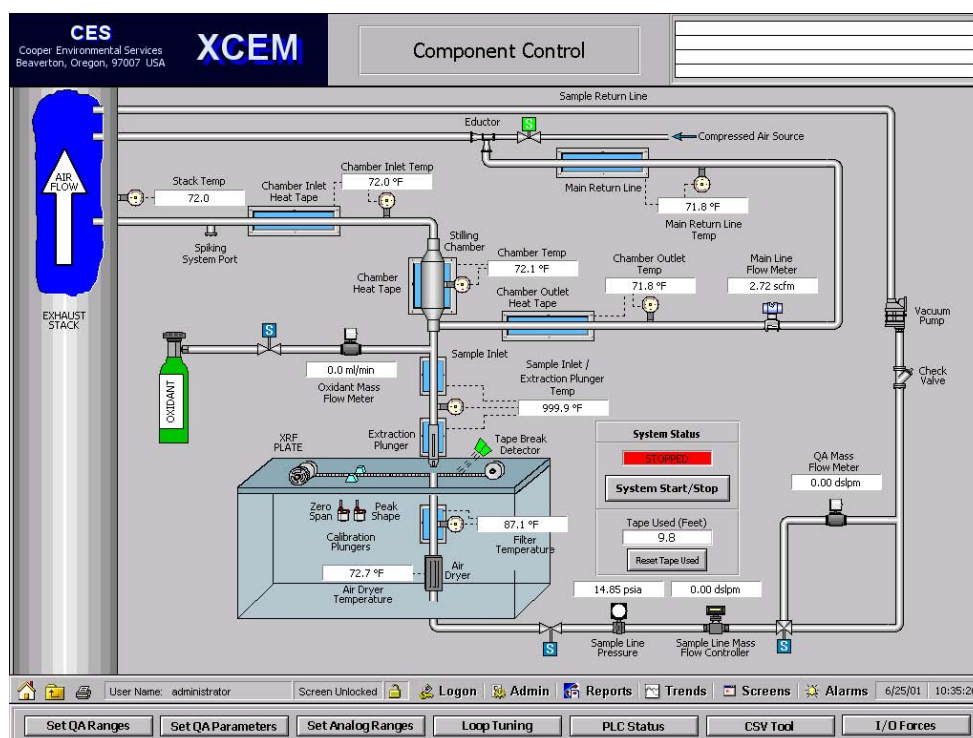

Figure 29. New Component Control Screen for XCEM software interface.

As described in the previous chapters, all day-to-day functions of the XCEM have been automated including flow and temperature control, concentration determination, and QA routines. Flow, temperature, concentration, pressure, and error messages are automatically recorded in a secure database. The data can readily be imported into excel or an equivalent program for subsequent analysis. Flows,

temperatures, concentrations, and pressure are logged in real-time on the screen. Images of the new XCEM and its components are shown in Figures 30–33. Installation of this unit at TEAD is described in more detail in a follow-on technical report.



Figure 30. XCEM cassettes.

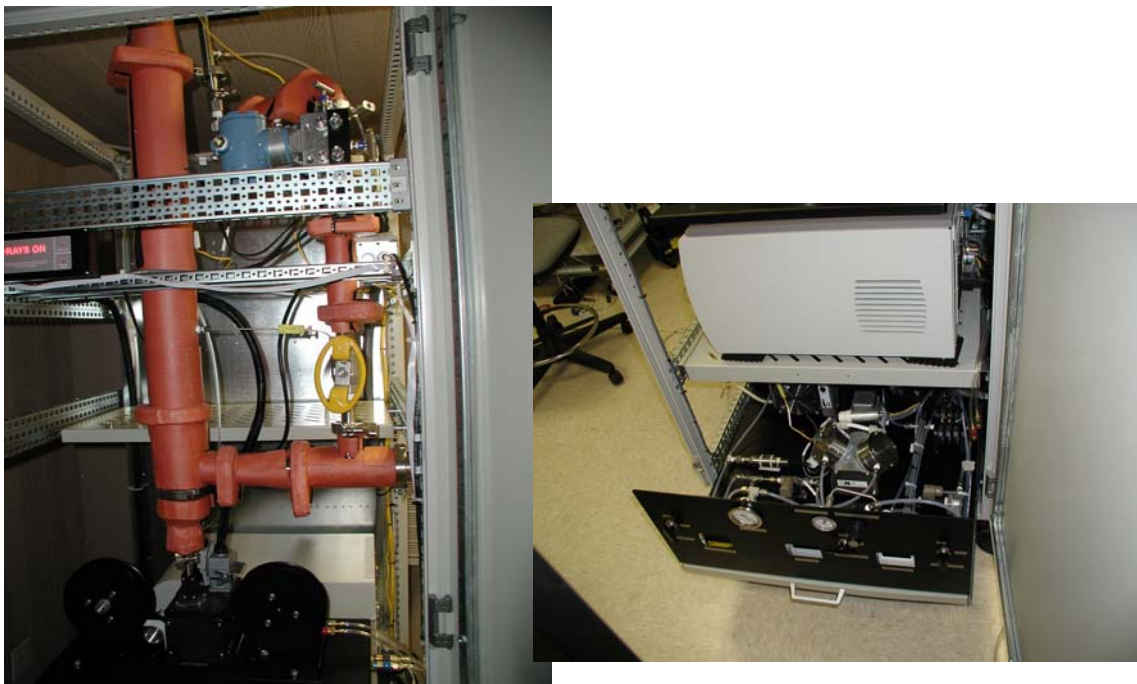

Figure 31. XCEM extraction system and cassette (left) and chassis (right).



Figure 32. XCEM with cabinet door open.



Figure 33. XCEM with computer system installed at TEAD.

5 Summary and Conclusions

The XCEM has been developed to provide for automated operations. It now includes features that improve ease-of-use and QA. The XCEM extraction, measurement, and data recording systems have been fully automated using a flexible WonderWare® software interface. The revised XCEM has been equipped with an automated daily zero and span check, as well as a mechanism for checking instrument drift, with every sample.

The XCEM RIF displayed good capture efficiencies for vapor phase Hg under reasonable temperature and flow conditions. The XCEM measured the mercuric nitrate injected during M29 comparison tests with a 20.4 RA using four test runs. This number meets the EPA's proposed PS-10 RA criterion when rounded to two significant digits. It is estimated that a larger number of test runs would bring that value below 20, so that the XCEM will likely also meet the RA criterion for Hg in future testing.

A nebulization spiking approach was used to provide very precise concentrations of all MACT metals over a wide range of concentrations (1 to 2000 mg/cm³). The XCEM agreed well with the M29 test runs for all elements except Ag. The XCEM displayed better precision than M29 and was able to report data every 12 min during the 4-day test period. M29 Ag concentrations differed dramatically from any other M29 or XCEM reported concentration. For this reason, and because of laboratory QA issues, it is believed that the low M29 Ag concentrations are a result of M29 sampling or analysis error.

The XCEM met the proposed PS-10 RA criteria for As, Cr, Hg, and Se with only four sample runs. It is estimated that the XCEM would also have met the Pb RA criterion if nine tests had been conducted. Cadmium, with an RA of 23 percent, did not meet the RA criterion.

Although the simulated stack gas contained the metals of interest and relatively high concentrations of nitric acid (~100 ppm), the simulated stack gas did not contain sulfur dioxide, fly ash, or nitrogen dioxide as might be seen in an actual incinerator stack. For this reason, additional testing under actual stack conditions is needed to ensure that the XCEM can perform as well in the field as it did for these tests.

A new XCEM incorporating the changes made in this report was constructed and installed at TEAD where it underwent M29 comparison tests under real incinerator conditions. The installation and field testing of the XCEM at TEAD are presented in a follow-on technical report.

References

- Bryson, S., C. Whitworth, and S. Kujawa. (2000). Final Report – Test and Evaluation of an X-Ray Fluorescence Based Multi-Element Metals Continuous Emission Monitor. Prepared for U.S. Army Corp of Engineers by MSE-TA, Inc., Butte, MT.
- Cooper Environmental Services (CES). (2001a). “XCEM User’s Guide,” Beaverton, OR, 2001.
- _____. (2001b). “XCEM Resource Manual,” Beaverton, OR, 2001.
- Cooper, J., B.E. Johnsen, K.J. Hay, and W. Watson (2000). Continuous Hazardous Element Analysis System for Ambient and Emissions Monitoring. Presented at regional AWMA Conference: Recent Advances in the Science and Management of Air Toxics. April 10, 2000.
- Flagan, R.C., and J.H. Seinfeld (1988). Fundamentals of Air Pollution Engineering, Prentice-Hall, Englewood Cliffs, NJ, pp 59-62, 146-159, 359-384.
- French, N. (1998). 1997 Performance Testing of Multi-Metal Continuous Emissions Monitors. Summary Report Prepared for the U.S. EPA and U.S. DOE by Sky+, Napa, CA.
- Fuchs, N.A., and A.G. Stutugin. (1966). Aerosol Science, edited by CN Davies, Academic Press, London, pp 1-30.
- Johnsen, B., J. Cooper, and B. Richards (1998). Evaluation of a Hazardous Elemental Sampling Train During EPA’s Continuous Emission Monitoring Test. Presented at Pacific Northwest AWMA Conference and International Conference on Incineration and Thermal Treatment Technologies. October 1, 1998.
- Josephson, Paul. (2003). Hazardous Waste Combustor Management Plan – AEC.
- Maximum Achievable Control Technology. (1999). Final Standards for Hazardous Air Pollutants for Hazardous Waste Combustors. Federal Register 52828-FR53077, Vol. 64, No. 189.
- _____. (1999b). Final Technical Support Document for HWC MACT Standards. Vol III. Selection of MACT Standards and Technology. Chapter 13. USEPA Contract 68-D2-0164.
- PS-10 (1996), Proposed Performance Specification 10 for Metal CEMS (Proposed 04/19/96) Found on the EPA website at: <http://www.epa.gov/ttn/emc/propperf.html>.
- Seltzer, M.D. (2000). “Performance Testing of a Multimetals Continuous Emissions Monitor”, J. Air Waste Mgt. Assoc., Vol. 60, No. 6.
- Ytalatalo, S., H. Toivonen, and J. Lehtinen. (2000). Authentication of Air Samples by Aerosol. Aerosol Science and Technology 33:419-426.

Abbreviations and Acronyms

AEC	U.S. Army Environmental Center
CAAA	Clean Air Act Amendments (of 1990)
CEM	continuous emission monitor
CERL	Construction Engineering Research Laboratory
CES	Cooper Environmental Services
CIF	carbon-impregnated filter
EPA	U.S. Environmental Protection Agency
ERDC	U.S. Army Engineer Research and Development Center
EQT	Environmental Quality Technology
HAP	Hazardous Air Pollutants
HEST	Hazardous Elemental Sampling Train
HVM	high volatile metals
HWC	hazardous waste combustors
ICP	inductively coupled plasma
LIBS	laser-induced breakdown spectroscopy
LVM	low volatile metals
M29	EPA Reference Method 29
mAmp	milli-ampere
MACT	Maximum Achievable Control Technology
MSE-TA	MSE Technology Applications, Inc.
NESHAP	National Emission Standards for Hazardous Air Pollutants
NIST	National Institute of Standards and Technology
PLC	programmable logic controller
PM	particulate matter
PS-10	EPA Performance Specification 10
QA	quality assurance
RA	relative accuracy
RIF	resin-impregnated filter
RSD	relative standard deviation

SCFM	standard cubic feet per minute
SVM	semi-volatile metals
TEAD	Tooele Army Depot (Utah)
XCEM	XRF-based continuous emission monitor
XRF	x-ray fluorescence

Chemical elements

Ag	silver
As	arsenic
Cd	cadmium
Cr	chromium
Hg	mercury
Pb	lead
Pd	palladium
Se	selenium

