

AD\_\_\_\_\_

Award Number: DAMD17-03-2-0015

TITLE: Remis: A Tool to Facilitate Innovation, Standardization,  
and Validation in the Creation of Ergonomic Surgical  
Simulators

PRINCIPAL INVESTIGATOR: W. Brent Seales, Ph.D.

CONTRACTING ORGANIZATION: University of Kentucky Research  
Foundation  
Lexington, Kentucky 40506-0057

REPORT DATE: February 2005

TYPE OF REPORT: Annual

PREPARED FOR: U.S. Army Medical Research and Materiel Command  
Fort Detrick, Maryland 21702-5012

DISTRIBUTION STATEMENT: Approved for Public Release;  
Distribution Unlimited

The views, opinions and/or findings contained in this report are those of the author(s) and should not be construed as an official Department of the Army position, policy or decision unless so designated by other documentation.

20050315 009

# REPORT DOCUMENTATION PAGE

Form Approved  
OMB No. 074-0188

Public reporting burden for this collection of information is estimated to average 1 hour per response, including the time for reviewing instructions, searching existing data sources, gathering and maintaining the data needed, and completing and reviewing this collection of information. Send comments regarding this burden estimate or any other aspect of this collection of information, including suggestions for reducing this burden to Washington Headquarters Services, Directorate for Information Operations and Reports, 1215 Jefferson Davis Highway, Suite 1204, Arlington, VA 22202-4302, and to the Office of Management and Budget, Paperwork Reduction Project (0704-0188), Washington, DC 20503

<b>1. AGENCY USE ONLY</b> (Leave blank)		<b>2. REPORT DATE</b> February 2005	<b>3. REPORT TYPE AND DATES COVERED</b> Annual (6 Jan 2004 - 5 Jan 2005)	
<b>4. TITLE AND SUBTITLE</b> Remis: A Tool to Facilitate Innovation, Standardization, and Validation in the Creation of Ergonomic Surgical Simulators			<b>5. FUNDING NUMBERS</b> DAMD17-03-2-0015	
<b>6. AUTHOR(S)</b> W. Brent Seales, Ph.D.				
<b>7. PERFORMING ORGANIZATION NAME(S) AND ADDRESS(ES)</b> University of Kentucky Research Foundation Lexington, Kentucky 40506-0057  <i>E-Mail:</i> seales@uky.edu			<b>8. PERFORMING ORGANIZATION REPORT NUMBER</b>	
<b>9. SPONSORING / MONITORING AGENCY NAME(S) AND ADDRESS(ES)</b> U.S. Army Medical Research and Materiel Command Fort Detrick, Maryland 21702-5012			<b>10. SPONSORING / MONITORING AGENCY REPORT NUMBER</b>	
<b>11. SUPPLEMENTARY NOTES</b>				
<b>12a. DISTRIBUTION / AVAILABILITY STATEMENT</b> Approved for Public Release; Distribution Unlimited				<b>12b. DISTRIBUTION CODE</b>
<b>13. ABSTRACT (Maximum 200 Words)</b>  The goal of this work is to develop and test new technologies that will break down the barriers that block more surgeons from attaining and continuing to practice (without injury or pain) high levels of skill in minimally invasive surgery (MIS). This project will develop new technology by concentrating on three major research thrusts: <b>Smart Image:</b> the project will develop and evaluate new approaches for extracting, fusing, and presenting information cues from imagery and other data sources; <b>Configurable Display:</b> the project will develop new approaches for presenting existing data (video, CT data) and extracted cues (3D reconstruction, haptic cues, etc.) to the user within a flexible, configurable display environment; <b>Ergonomic Assessment:</b> the project will use existing technology and build new techniques as needed to acquire crucial ergonomic data relative to key factors of patient position, technology configuration, and instrument design.				
<b>14. SUBJECT TERMS</b> Minimally invasive surgery, visualization, ergonomic assessment, simulation, modeling, calibration, smart image, acquisition			<b>15. NUMBER OF PAGES</b> 18	
			<b>16. PRICE CODE</b>	
<b>17. SECURITY CLASSIFICATION OF REPORT</b> Unclassified	<b>18. SECURITY CLASSIFICATION OF THIS PAGE</b> Unclassified	<b>19. SECURITY CLASSIFICATION OF ABSTRACT</b> Unclassified	<b>20. LIMITATION OF ABSTRACT</b> Unlimited	

## Table of Contents

Cover.....	1
SF 298.....	2
Table of Contents.....	3
Introduction.....	4
Major Accomplishments.....	4
Project Milestones 2004.....	8
Project Milestones 2005.....	13
Summary.....	14
Appendices.....	15

# **REVEAL: Reconstruction, Enhancement, Visualization, and Ergonomic Assessment for Laparoscopy**

## **1. Introduction**

Information cues available in laparoscopy and other forms of minimally invasive surgery are impoverished relative to cues available in open surgery. Acquiring surgical skill in such an environment is extremely challenging. Even after mastery, continued practice can lead to problems for the surgeon as indicated by frequent incidence of pain and injury associated with laparoscopy. The long-term impact on the surgeon performing these procedures is largely unknown.

The goal of this work is to develop and test new technologies that will break down the barriers that block more surgeons from attaining and continuing to practice (without injury or pain) high levels of skill in MIS. This project will develop new technology by concentrating on three major research thrusts:

- **Smart Image:** the project will develop and evaluate new approaches for extracting, fusing, and presenting information cues from imagery and other data sources.
- **Configurable Display:** the project will develop new approaches for presenting existing data (video, CT data) and extracted cues (3D reconstruction, haptic cues, etc.) to the user within a flexible, configurable display environment
- **Ergonomic Assessment:** the project will use existing technology and build new techniques as needed to acquire crucial ergonomic data relative to key factors of patient position, technology configuration, and instrument design.

## **2. Major Accomplishments**

In this section we provide a functional view of major tasks accomplished during the 2004 project year. These include (1) creation of the software development laboratory, (2) distribution of REVEAL Suite release 1.0, (3) distribution of REVEAL Suite release 2.0, (4) large-scale projection of stereo images from a laparoscopic probe, (5) creation of a UMM research operating room suite, (6) securing Human Studies IRB approval, and (7) creation of a study framework for quantitative analysis of latency on task performance.

### **Creation of Software Development Laboratory**

The software development laboratory was established at the beginning of the year. It consists of a distributed rendering system containing a 22 node cluster computer and a workstation for use as a coordinating "head node." Two additional workstations were acquired for use by the development staff. The workstations run RedHat Enterprise

Linux OS. We have also purchased 12 DLP projectors to create the large format display. Recently we purchased a rear projection polarity preserving screen for stereo display. The screen and projectors are mounted on a custom made truss. Low cost video cameras are used to calibrate the projectors.

A dual Xeon processor server is also part of the laboratory. The server is equipped with a tape drive and a dual-disk RAID controller. The server runs RedHat Advanced Server OS. We run a number of services on the server including (1) the website for the REVEAL project; (2) the CVS server and repository; (3) a MySQL database server and repository; (4) an NFS networked file system server; (5) and an LDAP user authentication server; and (6) centralized tape backup of all critical data. The server also performs regular nightly builds and tests on the most current version of the application in CVS.

Laboratory machines are interconnected using a gigabit network switch, providing reduced latency and increased throughput relative to current 10/100 Ethernet switches. All laboratory machines are on a dedicated network connected to the larger university network through a hardware firewall. Protection of laboratory resources by a firewall reduces the potential for infiltration by hackers or denial of service attacks.

A number of software development policies and procedures were drafted and implemented at the inception of the laboratory. These include (1) work practices and coding standards; (2) backup procedures; (3) nightly build and regression test procedures; and (3) protocols for using a common software repository (CVS).

### **REVEAL Suite Release 1.0**

Release 1.0 of the REVEAL tools provides large-scale high-resolution, high-brightness display of OpenGL applications and video using an arbitrary number of low-cost LCD or DLP projectors. It is based on the VIBE tool, previously developed by researchers at the University of Kentucky, with ancillary applications created to integrate the general purpose VIBE tool into a context appropriate for clinical use.

Using VIBE, an arbitrary number of projectors can be tiled together to create a single large scale display. The calibration algorithm used is robust, efficient and flexible. The projectors can be positioned casually and need not be aligned in any way. The projection surface can have any arbitrary shape and is not required to be flat. By using binary encoded patterns the calibration time is reduced to logarithmic order per projector. As part of our development activities, VIBE has been enhanced with background subtraction technique to reduce errors during the calibration process. This also lets us project on surfaces with imperfections.

The release also includes the *SmartVideo* application, providing real time video at ~30 frames per second on a gigabit network. Written using OpenGL, the *SmartVideo* program can play real-time video on the tiled display using the information gathered by the calibration program to produce a single, uniform frame. Although Chromium can run

most off-the-shelf OpenGL video applications, the frame rate obtained by using them on general-purpose hardware is very low. The *SmartVideo* application has been optimized to run efficiently on the cluster and network driving the tiled display and offer higher frame rates. This is achieved by fragmenting the captured video frames and sending only the required fragments to the appropriate projector. The number and size of fragments is computed using the calibration information. *SmartVideo* is also designed to preserve the aspect ratio on the tiled display based on dynamically detected calibration parameters.

A user friendly, portable, Java GUI is also provided with the suite. The GUI can be used to configure the calibration parameters and launch OpenGL applications without the need to manually update low-level configuration files.

## **REVEAL Suite Release 2.0**

Release 2.0 of the REVEAL tools, released in the middle of October 2004, provides a number of enhancements over version 1.0. The robustness and reliability of the calibration process has been improved. It now also includes a feature to perform a single-step fast calibration that works for all kinds of surfaces but with limited projector orientation. It assumes that the projectors are oriented such that their center-line of projection is orthogonal to the projection surface. This reduces calibration time to a constant value per projector. The calibration process has also been enhanced to adapt to situations where camera and viewer are positioned on opposite sides of the projection surface at the time of calibration.

The calibration software in this release can perform stereo calibration, calibrating two independent pools of tiled projectors so they can display stereo images. If the projectors are oriented suitably, fast stereo calibration can also be done. The calibration tries to maximize the overlap area available for stereo display.

In addition to the *SmartVideo* application, a *SmartStereo* application is provided with this release. The *SmartStereo* program can play real time stereo video on the stereo calibrated projectors. Synchronized video grabbing is included in the *SmartStereo* application. Synchronized capture ensures that left and right images are captured at as close to the same instant as possible. *SmartStereo* can play synchronized stereo video at 12-14 fps using the cluster computer and network configuration described above.

## **Large-Scale Projection of Stereo Images from Laparoscopic Probe**

Large scale projection of stereo images is a seamless stereo display formed by using two pools of calibrated projectors. The display is used to render high resolution stereo images with depth cues, thus creating a realistic 3D view for the user. The display can be used in multi-viewer environment and also for training purposes.

A large-scale projection system of stereo images is a complex system involving many hardware and software components. The hardware components of the system include two or more projectors, a camera, a gigabit network, a cluster of computers, each of which is

connected to a projector, a projection screen, polarized viewing goggles, polarized filters, and heat resistant custom designed filter mounts. The software components include proprietary stereo calibration software, the Chromium distributed rendering software framework, and the custom built OpenGL stereo applications.

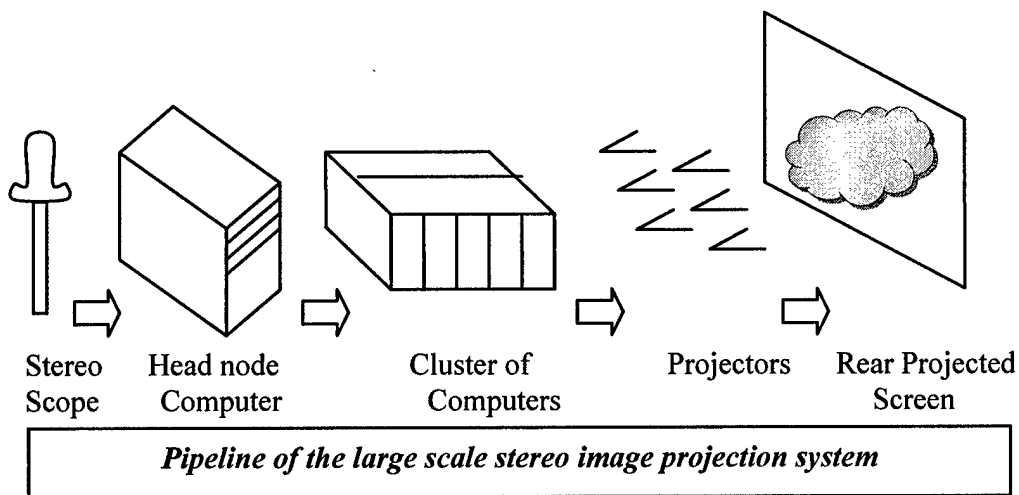

The projectors are divided into two sets, each set representing either a left-eye view or a right-eye view. Each set of projectors is independently calibrated using the functionality of VIBE calibration described above. The calibration information of the two views is processed and the stereo parameters are calculated. The OpenGL stereo applications use these stereo parameters to render the stereo display. The user only has to designate each projector as either left or right. No further user interaction is needed to calibrate and render the stereo display. Synchronization is provided at the image capture end and as well as at the image rendering end of the pipeline.

With eight projectors and eight render nodes, a 4X4 tiled stereo display is formed with a resolution of about 2000 X 1500 pixels. In our current system implementation the frame rate on gigabit network is around 12-14 frames per second. We are in the process of analyzing the performance and sensitivity of the current system with a goal of producing stereo video in the 25-30 frames per second range.

### **Creation of UMM Research Operating Room Suite**

We have secured space in the University of Maryland Medical Center for deployment of the experimental environment to be used for simulation, testing, and the human study protocol. This space is located in the old Operating Room suite and has the advantage of being equipped as a functional OR in terms of floor plan and dimension. This suite will be used as the major deployment platform in 2005 for the technology we have developed to be used in the human/animal protocol and assessment study to follow.

### **Human Studies IRB Approval**

We failed in 2004 to complete the IRB approval process through TATRC and the US Army. Until this approval is received we are unable to run the protocol as it relates to human subjects and animals. We nevertheless have moved forward with technical development, space and infrastructure acquisition, and readiness and planning to carry out the protocol once approvals are in place.

### **Quantitative Analysis of Latency on Task Performance**

We have begun a secondary task analysis and a latency task performance study to more closely define the parameters that will likely affect performance of the new technology (especially display settings). This analysis will inform system settings and help us establish the guidelines for the human study that will bring out the most effective results.

### **3. Project Milestones 2004**

The 2004 project plan included two distinct sets of milestones, one for visualization technology development activities, and a second for ergonomic assessment activities. The milestones and our progress in reaching each are assessed in the sections that follow.

#### **Primary Milestones: Visualization Technology**

##### 1) Hire and train development personnel

In November of 2003 two "Program Systems Analyst" positions were posted through the University of Kentucky hiring system. A total of 35 applications were received and vetted. Of these 35 applicants three were found to fully satisfy all qualifications outlined in the original job posting. These three were invited for interviews. Based on these interviews two candidates were selected to receive the first offers. Both accepted, successfully negotiated contracts, and started work on the project.

Yogesh Shukla, MS, joined the project as "Program Systems Analyst" on 15 December 2003. Praveen Devabhaktuni, MS, joined the project as "Program Systems Analyst" on 5 January 2004. Both have been actively involved in (1) establishing the project's laboratory and software development environment; and (2) developing significant new functionality to support large-scale projection of monocular and stereoscopic images from laparoscopic camera probes.

In addition to the full-time staff we have hired an undergraduate student, Ryan Davis, in a supporting role. Initially he was responsible for maintaining the project web site and cataloging project media (still photos, videos, *etc.*). His work in this area was performed with such efficiency and high quality that lately we have been transitioning him into a role that will involve him in an undergraduate research experience. Currently he is involved in defining and developing tools to support set-up and calibration of multi-projector displays.

During the summer of 2004 we employed a graduate student, Michael Jacobs from New York University, who focused on two major tasks: (1) developing tools to support experiments to determine the impact of latency on performance of minimally invasive surgical tasks; and (2) researching techniques for controlling program functionality that could be integrated into laparoscopic surgical procedures with little or no additional equipment and no negative impact on patient safety or clinician performance.

2) Establish software development environment (hardware, software, standards)

Early in 2004 we purchased computing equipment (a 22-processor cluster computer, desktop computers, networking infrastructure, *etc.*) to support research and development activities. Three workstations were purchased, two for the development staff and another to act as the head node to control the cluster computer.

The development staff configured and deployed this equipment to create (1) a test environment for laparoscopic capture and multi-projector display R&D, and (2) a development environment to support software development activities. A description of the software development environment follows in Section 4.

The development staff worked together to evolve a set of standards to be followed while working on the project. Specifically the Scrum methodology for agile software development has been adopted. This methodology is suitable for research project like ours where new research ideas and hypothesis need to be tested quickly to determine their feasibility before working to integrate them in the final product. The entire team meets every month to select items from the project backlog that can be implemented within a thirty day iteration called a "sprint." The idea is to focus on immediate goals and let the architecture and design evolve over multiple sprints. In addition the development team holds daily meetings to analyze progress and hurdles. Improvements and alternatives are discussed during these meetings. Team members regularly document problems as well as successes in a bug tracking database. Coding standards and testing procedures have been developed which guide the software development process.

3) Establish MIS test-bed (collect instruments, interfaces)

We have created a MIS test-bed on which new ideas are prototyped and integrated into an evolving suite of tools. Instruments and devices were acquired from various sources to build the test-bed. A laparoscopic trainer stand was obtained from Stryker. It is used as a crude simulation of a laparoscopic surgical site, to help medical students become accustomed to the limited visual cues available in MIS procedures, and develop manual dexterity in the use of MIS instruments. In addition, Stryker has also provided various surgical tools (clamps, probes, *etc.*) used for laparoscopy. Camera probes specialized for this kind of

surgical operation as well as controllers and light sources are also part of the test-bed.

Recently we acquired a stereoscopic camera probe from Viking Systems (formerly Vista Surgical Systems) to facilitate the development of stereo vision applications. A mannequin has also been acquired as part of our effort to develop a system for human anatomical studies based on non-planar projective displays.

The overall goal of developing the test-bed is to create a simulation environment where new display and image processing technologies can be tested and evaluated during the development process.

4) Gather product requirements

In keeping with the Scrum methodology, we have approached requirements gathering as an ongoing process, rather than single monolithic phase. Throughout the year formal and informal meetings between software developers at the UK site and personnel focused on ergonomics issues at UMM have been held. During those meetings the needs of UMM researchers have been elicited and reformulated as potential new features for the REVEAL suite of tools being developed by the UK researcher and development team.

5) Analyze product requirements

Requirements gathered as described in (4) above have been reformulated as individual implementable features and entered into the project backlog, a repository for maintaining a list of known bugs and potential features. Each month this backlog is assessed, the items are prioritized, and items are selected for implementation as part of the month's development activities.

6) Hold a multi-site project workshop meeting

On November 17<sup>th</sup> UK and UMM researchers associated with the REVEAL project met for a multi-site project workshop at the University of Maryland Medical Center. During this meeting progress toward the year's milestones was assessed, presentations were made covering significant results achieved, and plans were made for continuing progress into the next year and continuing inter-site coordination.

7) Define a scalable real-time architecture for multi-input, multi-transformation, multi-display MIS support

The diagram below describes the architecture of the display system that has been developed. We create a large format display using an array of arbitrarily positioned projectors which are calibrated using the VIBE software. Each projector is driven by a node in the cluster. A head node works as the

coordinator, determining how to split and distribute the display stream among the projectors.

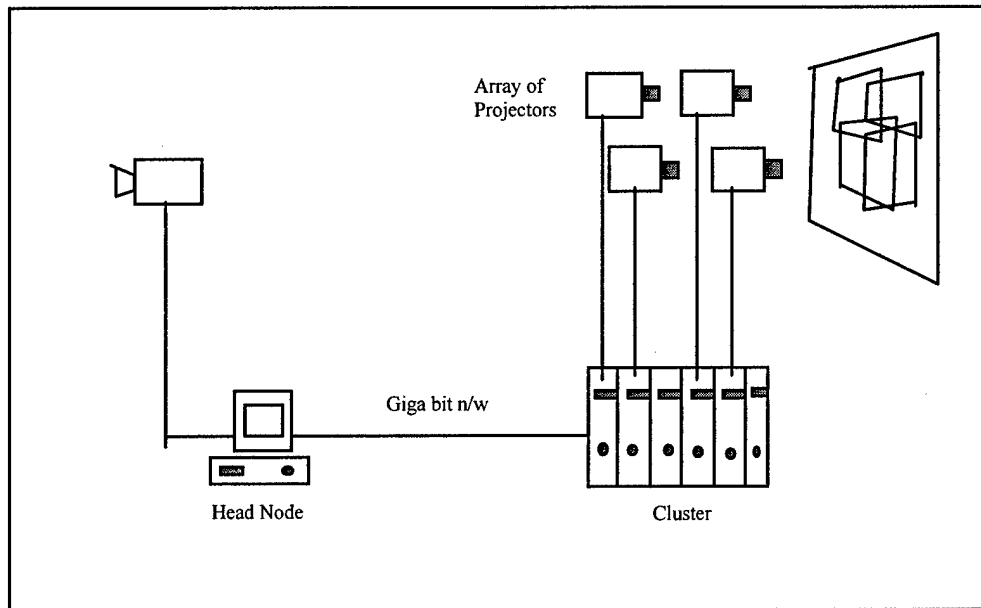

The head node and the cluster nodes are connected through a gigabit network to ensure minimum latency in the distribution of the display stream. We run Chromium on the head node and also on each of the cluster nodes. The OpenGL compatibility of Chromium ensures that most applications can be run on this architecture without any changes. On the head node Chromium uses the calibration information to split and distribute the display stream. VIBE adds an additional stream processing unit (SPU) to Chromium at the cluster end which receives the display stream from the head node and applies warping and blending using the calibration information to create a large tiled, seamless display.

#### 8) Identify re-usable components from public domain and outside researchers

Identifying externally developed, reusable components has had several advantages. First, the use of components that perform generic tasks has allowed us to concentrate on tasks specific to our domain. Second, use of industry standard tools opens a wide range of input sources to us without any effort on our part.

The principal public domain components that we have adopted are as follows:

OpenGL – An industry standard graphics library and API. It is used by application programs as a common interface for generating elaborate graphics displays from 3D models. Using OpenGL as the graphics library/API for our project has allowed us to incorporate a number of existing general-purpose and

medical imaging software applications into our system with no programming effort.

Chromium – An OpenGL compatible, generic, public domain software system for distributed rendering. Chromium is the framework that supports our projective display system—a single video source is received, divided by a small application program, processed through the Chromium distributed rendering system, and displayed using another small application program from the VIBE system.

OpenCV – A public domain library containing implementations of standard computer vision algorithms. Use of OpenCV has enabled our development team to concentrate on novel applications of computer vision techniques to our problem domain, leveraging tried and tested implementations of classic algorithms with minimal effort.

CVS – Use of CVS controls concurrent access to source code and documentation files, and creates a repository that organizes a multi-release project into discrete “versions.” This enables simultaneous development by the staff and versioning of ongoing work.

Mantis – To document and maintain the project backlog required by Scrum we use the Mantis bug tracking system. The development staff track tasks assigned to them and record progress and problems regularly using Mantis.

#### 9) Implement first iteration of architectural framework

The goal of the first iteration was to create a flexible, low cost, large format display system. We have used inexpensive off-the-shelf projectors and hardware. Another objective was to create a generic display system that would support a wide array of applications. Keeping the system flexible meant that the projectors were not required to be aligned in any rigid way. They could be tiled arbitrarily and calibrated to create a large seamless display.

As part of the first year’s effort we implemented an efficient and robust projector calibration technique for monocular and stereo projection. We also developed a real time video application for the tiled display. A synchronized stereo video application has been developed that can run on the stereo calibrated system. Further details of our system are presented below.

#### 10) Implement flexible display back-end for unprocessed probe camera data

We have implemented our first iteration of a display back-end. This work encompasses the *SmartVideo* and *SmartStereo* applications. These tools provide a framework for (1) efficient display of unprocessed probe camera data, and (2)

future integration of computer vision techniques to improve and enhance probe camera images in real-time and near-real time.

### **Primary Milestones: Ergonomic Assessment**

- 1) Obtain UMD IRB/IACUC approval
- 2) Hire and train development personnel
- 3) Establish ergonomic assessment environment (space, hardware, software, assessment methodologies)
- 4) Organize human subjects for baseline tasks
- 5) Analyze assessment hardware/software system requirements
- 6) Perform baseline assessment study using human subjects completing tasks in training environment
- 7) Define technical requirements for improved assessment technology
- 8) Process and interpret baseline study using trainer boxes and assessment environment
- 9) Hold a multi-site project workshop meeting
- 10) Conduct follow-on study with humans completing laparoscopic baseline tasks on animals

## **4. Project Milestones 2005**

The 2005 project plan again included two distinct sets of milestones for visualization technology development activities and ergonomic assessment activities. The milestones and our plans for reaching each during the coming year are assessed in the sections that follow.

### **Primary Milestones: Visualization Technology**

- 1) Deploy and evaluate first iteration of cluster-based distributed architectural framework

The November multi-site project workshop included planning for the deployment of UK REVEAL developed processing and display systems in the UMM research operating room suite. Deployment is planned for early 2005.

- 2) Deploy and evaluate display back-end for probe camera data

The November multi-site project workshop included planning for the deployment of UK REVEAL developed processing and display systems in the UMM research operating room suite. Deployment is planned for early 2005.

- 3) Integrate stereo probe device support into acquisition and back-end display framework

Work on this task commenced in late 2004 and we have already nearly completed a first prototype of a straight-through stereo video display system for the Viking Systems probe and controller.

- 4) Design and test algorithms for low-latency probe-data cue extraction (reconstruction, enhancement, overlays)

Some preliminary work on user-interface design issues was carried out by the summer student in 2004. Work is scheduled to continue in 2005.

- 5) Design and test algorithms for non-invasive ergonomic cue extraction in simulation/surgical setting

Work is scheduled to commence in 2005 with additional input from UMM researchers and clinicians.

- 6) Design display mode alternatives for same-display integration of probe-data, extracted cue data and other overlay information

Work is scheduled to commence in 2005.

- 7) Test and support performance analysis of trial environment configurations: stereo, display configurations, integrated cues

Performance analysis and management activities commenced in 2004 and are ongoing. We are actively analyzing the performance of various configurations, and creating requirements for enhancements required for more accurate and timely reporting of performance statistics in future releases of the REVEAL suite.

### **Primary Milestones: Ergonomic Assessment**

- 1) Organize performance trials on baseline tasks
- 2) Assess latency impact of distributed architecture
- 3) Upgrade hardware/software environments
- 4) Conduct implementation tests on stereo-probe acquisition and display
- 5) Design and perform stereo-based human skills study
- 6) Design and test non-invasive assessment algorithms
- 7) Design and perform human skills study with trial environment configurations: display, integrated cues, stereo

### **5. Summary**

We met all technical milestones in 2004 and are eager to move forward with the plan for 2005. We have been hampered on the clinical/human subjects side of the project because we have still not obtained final approval for our protocols. We envision accelerated forward progress once these approvals are in place, and we anticipate that to occur early in Project Year 3 (early 2005).

## Appendix A: Project Personnel

Name	Role	Location	2005 FTE
W. Brent Seales, PhD	Principal Investigator	UK College of Engineering	31.5%
Adrian Park, MD	Co-Principal Investigator	UM School of Medicine	
Tsegay Baraki	Administrative Support (Budget, Reporting)	UMMS Department of General Surgery	
Jesus Caban	Research Assistant	UK Department of Computer Science	100%
C. Melody Carswell	Senior Researcher	UK Department of Psychology	25%
Duncan Clarke, PhD	Technical Project Lead	Fremont Associates, LLC	60%
Ryan Davis	Student Programmer	UK Center for Visualization	
Praveen Devabhaktuni, MS	Program Systems Analyst	UK Center for Visualization	100%
Ivan George	Technical Support	UMMS Department of General Surgery	
Kimberly Hall	Administrative Support (Budget, Clerical)	UK Center for Visualization	20%
Stephen Kavic, MD	Senior Researcher	UM School of Medicine	
Huey Khoo	Research Assistant	UK Department of Computer Science	100%
Linda Rice, RN, CCRC	Administrative Support (Research Protocols)	UK Medical Center	20%
Ross Segan, MD	Senior Researcher	UM School of Medicine	
Robert Shapiro, PhD	Senior Researcher	UK Department of Kinesiology and Health	5%
Yogesh Shukla, MS	Program Systems Analyst	UK Center for Visualization	100%
Donald Witzke, PhD	Senior Researcher	UK Department of Pathology	5%

## Appendix B: Laboratory Facilities

### UK Software Development Laboratory

- Project Staff Office
  - Location: 801 KU Building
  - Purpose: Working environment for day-to-day activities of software developers.
  - Equipment:
    - Two developer workstations
    - Twin-processor Dell PowerEdge server with DLT tape drive
    - Cisco firewall/router
  
- High-Performance Multi-Projector Display Laboratory
  - Location: 871 KU Building
  - Purpose: Test environment for MIS video image processing techniques and large-scale projected displays.
  - Equipment:
    - RackSaver 22 Processor cluster computer with gigabit backplane
    - Dell workstation
    - Gigabit network switch
    - 12 DLP projectors with overhead mounts
    - Custom heat- and vibration-tolerant filters w/ mounts for stereo projection
    - 7.5' x 10' back-projected polarity-preserving screen with mounting frame
    - General purpose Canon video camera
    - Stryker trainer stand with auxiliary high-definition LCD display
    - 2 Stryker 888 high resolution cameras, controllers and lens probes
    - Stryker light source
    - Viking Systems stereo camera probe, controller and light source
    - Assorted MIS surgical instruments
  
- Project Office
  - Location: 883 KU Building
  - Purpose: Working environment for project management and small team meetings.
  - Equipment: One general purpose computer.
  
- Web site
  - Location: <http://halsted.vis.uky.edu>
  - Purpose: Provide general overview of project activities, distribute project documents and software, and serve as repository for project images (still and video).

## **UMM Research Operating Room Suite**

- Simulation space in old OR Suite
  - Location: UMB Medical Center
  - Purpose: Working environment for day-to-day activities of human subjects using technology and simulation environment
    - Renovations for power, computer cluster mounting, network backbone
    - Mounting hardware for projection, screen surface material, cameras for observation

## ***Appendix C: Publications***

J Caban, W.B. Seales, A. Park. Heterogeneous Displays for Surgery and Surgical Simulation, MMVR 2005, Long Beach, CA.

A. Park. A novel, comprehensive model of paraesophageal hernias, SAGES 2005.

A. Park. 3-Dimensional Modeling based on Computed Tomography (CT) Data for Evaluation and Preoperative Planning in Adrenalectomy: Surgically-Relevant Imaging, SAGES 2005.

A. Park. A novel conceptual model of the current surgical classification of paraesophageal hernias using dynamic three-dimensional reconstruction. SAGES 2005.

A. Park. Repair of a complex foregut hernia aided by novel three-dimensional surgical reconstruction. SAGES 2005

A. Park. The application of three-dimensional imaging in planning operative treatment of gastrointestinal stromal tumors. **(SAGES 2005, submitted in video)**

---