



**Examination of Alternative Pretreatments to Hexavalent
Chromium-Based DOD-P-15328D Wash Primer
for MIL-A-46100D High Hard Steel Armor**

by Brian E. Placzankis, Chris E. Miller, and John V. Kelley

ARL-TR-3393

January 2005

NOTICES

Disclaimers

The findings in this report are not to be construed as an official Department of the Army position unless so designated by other authorized documents.

Citation of manufacturer's or trade names does not constitute an official endorsement or approval of the use thereof.

Destroy this report when it is no longer needed. Do not return it to the originator.

Army Research Laboratory

Aberdeen Proving Ground, MD 21005-5069

ARL-TR-3393

January 2005

Examination of Alternative Pretreatments to Hexavalent Chromium-Based DOD-P-15328D Wash Primer for MIL-A-46100D High Hard Steel Armor

Brian E. Placzankis, Chris E. Miller, and John V. Kelley
Weapons and Materials Research Directorate, ARL

REPORT DOCUMENTATION PAGE			<i>Form Approved</i> OMB No. 0704-0188		
Public reporting burden for this collection of information is estimated to average 1 hour per response, including the time for reviewing instructions, searching existing data sources, gathering and maintaining the data needed, and completing and reviewing the collection information. Send comments regarding this burden estimate or any other aspect of this collection of information, including suggestions for reducing the burden, to Department of Defense, Washington Headquarters Services, Directorate for Information Operations and Reports (0704-0188), 1215 Jefferson Davis Highway, Suite 1204, Arlington, VA 22202-4302. Respondents should be aware that notwithstanding any other provision of law, no person shall be subject to any penalty for failing to comply with a collection of information if it does not display a currently valid OMB control number. PLEASE DO NOT RETURN YOUR FORM TO THE ABOVE ADDRESS.					
1. REPORT DATE (DD-MM-YYYY) January 2005		2. REPORT TYPE Final		3. DATES COVERED (From - To) July 2002–September 2003	
4. TITLE AND SUBTITLE Examination of Alternative Pretreatments to Hexavalent Chromium Based DOD-P-15328D Wash Primer for MIL-A-46100D High Hard Steel Armor			5a. CONTRACT NUMBER		
			5b. GRANT NUMBER		
			5c. PROGRAM ELEMENT NUMBER		
6. AUTHOR(S) Brian E. Placzankis, Chris E. Miller, and John V. Kelley			5d. PROJECT NUMBER 622105 H84		
			5e. TASK NUMBER		
			5f. WORK UNIT NUMBER		
7. PERFORMING ORGANIZATION NAME(S) AND ADDRESS(ES) U.S. Army Research Laboratory ATTN: AMSRD-ARL-WM-MC Aberdeen Proving Ground, MD 21005-5069			8. PERFORMING ORGANIZATION REPORT NUMBER ARL-TR-3393		
9. SPONSORING/MONITORING AGENCY NAME(S) AND ADDRESS(ES) PM Brigade Combat Team 6501 E. Eleven Mile Road Warren, MI 48397-5000			10. SPONSOR/MONITOR'S ACRONYM(S)		
			11. SPONSOR/MONITOR'S REPORT NUMBER(S)		
12. DISTRIBUTION/AVAILABILITY STATEMENT Approved for public release; distribution is unlimited.					
13. SUPPLEMENTARY NOTES					
14. ABSTRACT Hexavalent Chromium based compounds with their associated health and environmental risks have necessitated reductions and even eliminations of their usage in U.S. Army weapon systems. These compounds are primarily associated with pretreatments and conversion coatings applied prior to primers and topcoats that make up the Chemical Agent Resistant Coating (CARC) coating system. Despite these hazards, for armor steels such as MIL-A-46100D high hard alloy, hexavalent chromium based DOD-P-15328D wash primer is still commonly used. This study explores the effectiveness of wash primer alternatives with respect to corrosion, adhesion, and susceptibility to Environmentally Assisted Cracking (EAC) issues. The alternatives studied were: spray based zinc phosphate in accordance with TT-C-490, grit blast only with no other pretreatment, and grit blast with a rust inhibiting sealer.					
15. SUBJECT TERMS zinc phosphate, MIL-A-46100D, high hard armor steel, wash primer, hexavalent, chromium					
16. SECURITY CLASSIFICATION OF:			17. LIMITATION OF ABSTRACT UL	18. NUMBER OF PAGES 52	19a. NAME OF RESPONSIBLE PERSON Brian E. Placzankis
a. REPORT UNCLASSIFIED	b. ABSTRACT UNCLASSIFIED	c. THIS PAGE UNCLASSIFIED			19b. TELEPHONE NUMBER (Include area code) 410-306-0841

Contents

List of Figures	iv
List of Tables	v
Acknowledgments	vi
1. Introduction	1
2. Experimental Procedure	2
3. Results	15
3.1 Pull-off Adhesion	15
3.2 Accelerated Corrosion.....	15
3.3 Resistance to Flash Rusting.....	19
3.4 Rising Step Load (K_{IEAC})	32
4. Discussion	32
5. Conclusions	37
6. References	38
Distribution List	41

List of Figures

Figure 1. Brigade Combat Team (BCT) Stryker Interim Armored Vehicle (IAV) in Standard Infantry Carrier Vehicle (ICV) configuration.....	2
Figure 2. Process steps for abrasive blast with primer coating applied at MILITEX and followed for the laboratory procedure.....	3
Figure 3. Process steps for abrasive blast with CHEMINHIB 420 abrasive blast at MILITEX with primer applied at GDLS, London facility and followed for the laboratory procedure.	4
Figure 4. Process steps for the proposed spray zinc phosphate followed in the laboratory procedure.	4
Figure 5. Test chamber configuration used for ASTM B 117-90 neutral salt fog.....	5
Figure 6. Test chamber configuration used for GM 9540P cyclic corrosion.....	5
Figure 7. Pull-off hydraulic adhesion test (ASTM D 4541).	8
Figure 8. K_{IEAC} test specimen configuration (25).	12
Figure 9. Crack plane orientation identification codes for rolled plate (24).	13
Figure 10. Identification of crack initiation load P_{IEAC}	13
Figure 11. Rising step load specimen in test fixture.	14
Figure 12. Rising step load test configuration.	14
Figure 13. ASTM D 4541 pull-off adhesion results abrasive blast with DOD-P-15328D (wash primer) Cr^{+6} based legacy pretreatment.	16
Figure 14. ASTM D 4541 pull-off adhesion results for abrasive blast only.....	16
Figure 15. ASTM D 4541 pull-off adhesion results for abrasive blast with CHEMINHIB 420 water soluble inhibitor coating.....	17
Figure 16. ASTM D 4541 pull-off adhesion results for abrasive blast with spray zinc phosphate pretreatment.	17
Figure 17. 53022(II)/53039A at 1500 hr ASTM B 117-90 salt fog.....	21
Figure 18. 53022(II)/64159 at 1500 hr ASTM B 117-90 salt fog.	22
Figure 19. Legacy coating system (a) vs. current coating systems (b and c) pretreated with spray zinc phosphate at 1500 hr ASTM B 117-90 salt fog.....	23
Figure 20. 53022(II)/53039A at 80 cycles GM 9540P cyclic corrosion.....	25
Figure 21. 53022(II)/64159 at 80 cycles GM 9540P cyclic corrosion.	26
Figure 22. Legacy coating system (a) vs. current coating systems (b and c) pretreated with spray zinc phosphate at 80 cycles GM 9540P cyclic corrosion.....	27
Figure 23. Initial appearance of bare pretreated specimens prior to 100% relative humidity exposure.	28

Figure 24. Appearance of bare pretreated specimens after 16 hr of ASTM D 1735 100% relative humidity exposure.	29
Figure 25. Initial appearance of bare pretreated specimens prior to 1 week of 27 °C, 69% relative humidity ambient laboratory exposure.	30
Figure 26. Appearance of bare pretreated specimens after 1 week of 27 °C, 69% relative humidity ambient laboratory exposure.	31
Figure 27. Average K_{IEAC} for pretreated 4340 and 46100 by orientation.	33
Figure 28. Changes in phosphate quality/appearance from adjustments to free acid concentration point values via increases of Henkel Primer 40 to the BONDERITE 952 spray zinc phosphate solution.	36

List of Tables

Table 1. GM 9540P cyclic corrosion test details.	6
Table 2. Evaluation of scribed coated specimens subjected to corrosive environments - ASTM D 1654-79A.	7
Table 3. Laboratory conditions for pull-off adhesion ASTM D 4541.	8
Table 4. Typical mechanical properties of MIL-A-46100D high hard armor and other high strength steels.	9
Table 5. Chemical composition of MIL-A-46100D high hard armor ^(a, b)	10
Table 6. Precracking conditions for K^{IEAC} CV2 specimens.	11
Table 7. Readings (psi) for ASTM D 4541 pull-off adhesion.	18
Table 8. ASTM D 1654-79A scribe creepback ratings for 1500 hr ASTM B 117-90 salt fog exposure.	20
Table 9. ASTM D 1654-79A scribe creepback ratings for 80 cycle GM 9540P cyclic corrosion exposure.	24
Table 10. Experimental conditions and K_{IEAC} values for rising step load specimens.	34

Acknowledgments

The authors thank the following people for their knowledge and support during the performance of this study: Carmen Uffen, Keith Clavett, and Lilliana Pereira of GDLS, London, Ontario, for information and assistance on current coating processes; Janet Byrne of PPG Industries, Euclid, OH, who cross-referenced the Canadian and U.S. product names and supplied PPG product samples for evaluation and information for product mixing/application procedures; John Beatty and Jonathan Montgomery of the U.S. Army Research Laboratory for their additional knowledge in high strength armor steels and assistance in troubleshooting the tensile test load frame; and finally, the authors wish to recognize Terry Dean and Geoff Hoerauf of PM BCT for their funding, guidance, and, most of all, their patience with respect to the unanticipated additional time needed for completion of this study.

1. Introduction

Hexavalent Chromium based compounds with their associated health and environmental risks have necessitated reductions and even eliminations of their usage in U.S. Army weapon systems (1). These compounds are primarily associated with pretreatments and conversion coatings applied prior to primers and topcoats that make up the Chemical Agent Resistant Coating (CARC) coating system. Despite these hazards, for armor steels such as MIL-A-46100D (2) high hard alloy, hexavalent chromium based DOD-P-15328D (3) wash primer is still commonly used. This study explores the effectiveness of wash primer alternatives with respect to corrosion, adhesion, and susceptibility to environmentally assisted cracking (EAC) issues. The alternatives studied were: spray based zinc phosphate in accordance with TT-C-490D (4), grit blast only with no other pretreatment, and grit blast with a rust inhibiting sealer.

Historically, DOD-P-15328D wash primer has extensively been used as one possible pretreatment portion of the CARC coating system for steel and aluminum substrates. The hexavalent chromium component present in the wash primer promotes adhesion of the primer to the substrate and inhibits the nucleation and growth of corrosion sites. In order to comply with current Army policies and DOD directives, all new Army acquisition must be hexavalent chromium free. Three hexavalent chromate free solutions were selected for study based upon feedback from the Brigade Combat Team (BCT) Stryker Interim Armored Vehicle (IAV) Environmental Management Team and process engineers at the General Dynamics Land Systems (GDLS) London, Ontario, Canada assembly facility for the Stryker family of armored vehicles (figure 1). These three pretreatments were: Abrasive blast only, Abrasive Blast + PPG CHEMINHIB^{*} 420 (5), and Abrasive Blast + Henkel Surface Technologies BONDERITE[†] 952 spray based zinc phosphate. Performance criteria applied to replacement candidates for hexavalent chromate based DOD-P-15328D wash primer included corrosion resistance and adhesion, as well as process controls and ease of application during manufacturing.

A particular concern for this study is the armor steel itself. The yield strength for MIL-A-46100D high hard armor steel used in Stryker and other weapon systems is at or beyond the 1400 MPa (6) level commonly noted for high risk to cracking via hydrogen exposure near the surface. This form of hydrogen attack, usually referred to as EAC, can occur as a result of corrosion in a natural environment and can also be introduced via aqueous surface processing procedures such as cleaning or plating. Zinc phosphate as a pretreatment for steels is common in the automotive industry; however, it is normally used on much lower strength steels. The phosphating process is aqueous by nature and includes acidic steps. Due to the high strength level of the MIL-A-46100D armor steel, the potential for environmentally assisted cracking from potential hydrogen sources such as a spray zinc phosphate remains a critical concern and cannot be underestimated.

^{*}CHEMINHIB is a registered trademark of PPG Industries, Inc., Euclid, OH.

[†]BONDERITE is a registered trademark of Henkel Surface Technologies, Madison Heights, MI.



Figure 1. Brigade Combat Team (BCT) Stryker Interim Armored Vehicle (IAV) in Standard Infantry Carrier Vehicle (ICV) configuration.

Funding for this study was provided by the U.S. Army Tank Automotive and Armaments Command (TACOM) via PM BCT.

2. Experimental Procedure

High hard armor steel test panels (120 each nominally $10.16 \times 15.24 \times 0.635$ cm) of MIL-A-46100D were prepared. Prior to pretreatment and testing, all panels were clearly designated for their respective pretreatments. Due to the extreme hardness of the material, panel identification was executed via removal of panel corners through surface grinding. The three panel processing sets and their quantities prepared were identified as follows:

- All four corners intact–Abrasive Blast (30)
- One corner removed–Abrasive Blast with CHEMINHIB 420 (30)
- Two corners removed–Abrasive Blast with spray zinc phosphate (30)

Each of the three sets of test panels were further subdivided and coated with two different primer/topcoat systems:

- MIL-P-53022-10 (7) (type II) primer with MIL-C-53039A (8) topcoat (15)
- MIL-P-53022-10 (type II) primer with MIL-DTL-64159 (9) (type II) topcoat (15)

An additional control set of 30 panels representative of legacy processing methods was prepared with hexavalent chromium containing DOD-P-15328D and was coated with MIL-P-53022-10 (type I) primer and MIL-C-46168 (10) topcoat. All of the test panels' respective primer coats

were applied within 24 hr after the surface preparation and pretreatment. The abrasive blasting step was performed on all panels and consisted of SiC media applied to a SSPC-SP 10 (11) near white metal finish with a 1.5-mil profile. Applications of spray zinc phosphate and CHEMINHIB 420 surface pretreatments were performed on the blasted panels following manufacturer’s instructions and procedures used at the GDLS London facility. To avoid confusion, it should be noted that KLEENINHIB* 486 (12) product used in cleaning and shipping phases for bare Stryker hulls is also known by the trade name CHEMKLEEN 340 in the United States. Both of these products are chemically identical. The CHEMINHIB 420 was prepared from PPG Industries RECOOL* ADDITIVE 15 (13) concentrate. Additional spray zinc phosphated panels were set aside and sampled for coating weight using a heated chromic acid stripping solution. The spray zinc phosphate applied on the 46100 corrosion test panels fell within the range for zinc phosphate coating weight specified in TT-C-490 and averaged 320 mg/ft². The application procedures for the different pretreatment scenarios as performed in production and in laboratory conditions are described in figures 2–4 (14–17).

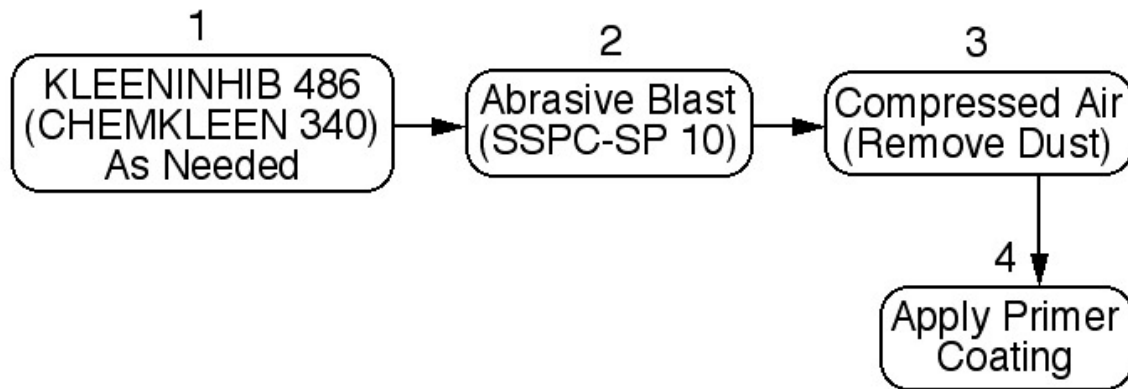

Figure 2. Process steps for abrasive blast with primer coating applied at MILITEX and followed for the laboratory procedure.

Two corrosion test chambers, a Harshaw Model 22 standard neutral salt fog and an Attotech Model CCT-NC-30 cyclic corrosion test chamber, were used to evaluate the armor steel test panels. Figures 5 and 6 show the test chambers used throughout the study. Immediately prior to exposure, the panels were all “X” scribed using a standard carbide tipped hardened steel scribe. The scribed panels were placed into the respective chambers and exposed to ASTM B 117-90 (18) and General Motors 9540P (19) accelerated corrosion test environments. The ASTM B 117-90 neutral salt fog conditions are 95°F with saturated humidity and atomized fog of 5% NaCl solution. The GM 9540P test consists of 18 separate stages that include the following: saltwater spray, humidity, drying, ambient, and heated drying. The environmental conditions and duration of each stage for one complete 9540P cycle are provided in table 1. The standard 0.9% NaCl, 0.1% CaCl₂, 0.25% NaHCO₃ test solution was used. In addition, the cyclic chamber was calibrated with standard steel mass loss calibration coupons as described in the GM 9540P test specification.

*KLEENINHIB and RECOOL are registered trademarks of PPG Industries, Inc., Euclid, OH.

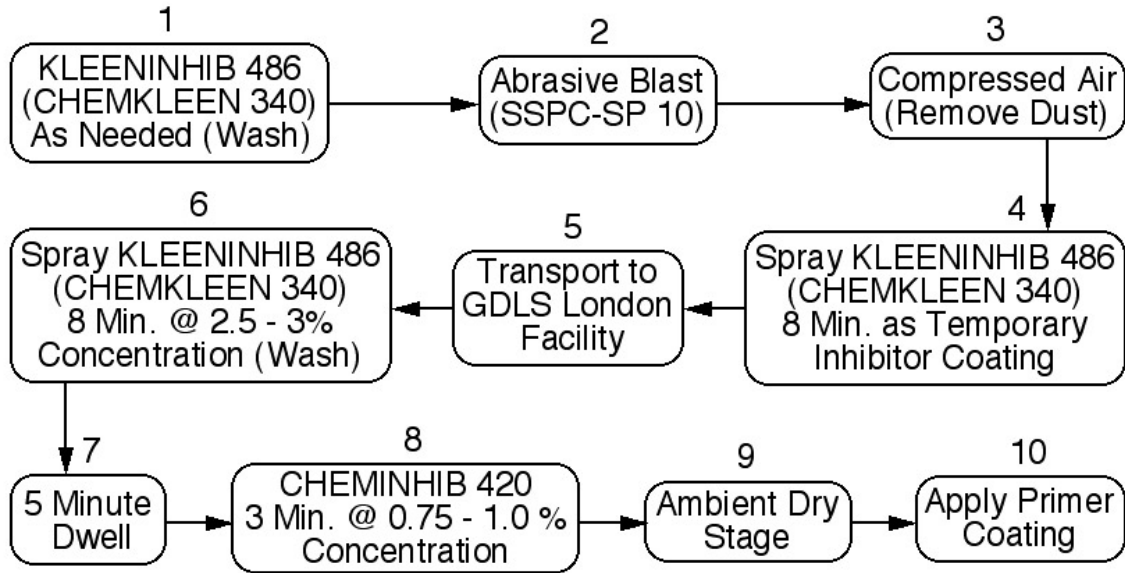

Figure 3. Process steps for abrasive blast with CHEMINHIB 420 abrasive blast at MILITEX with primer applied at GDLS, London facility and followed for the laboratory procedure.

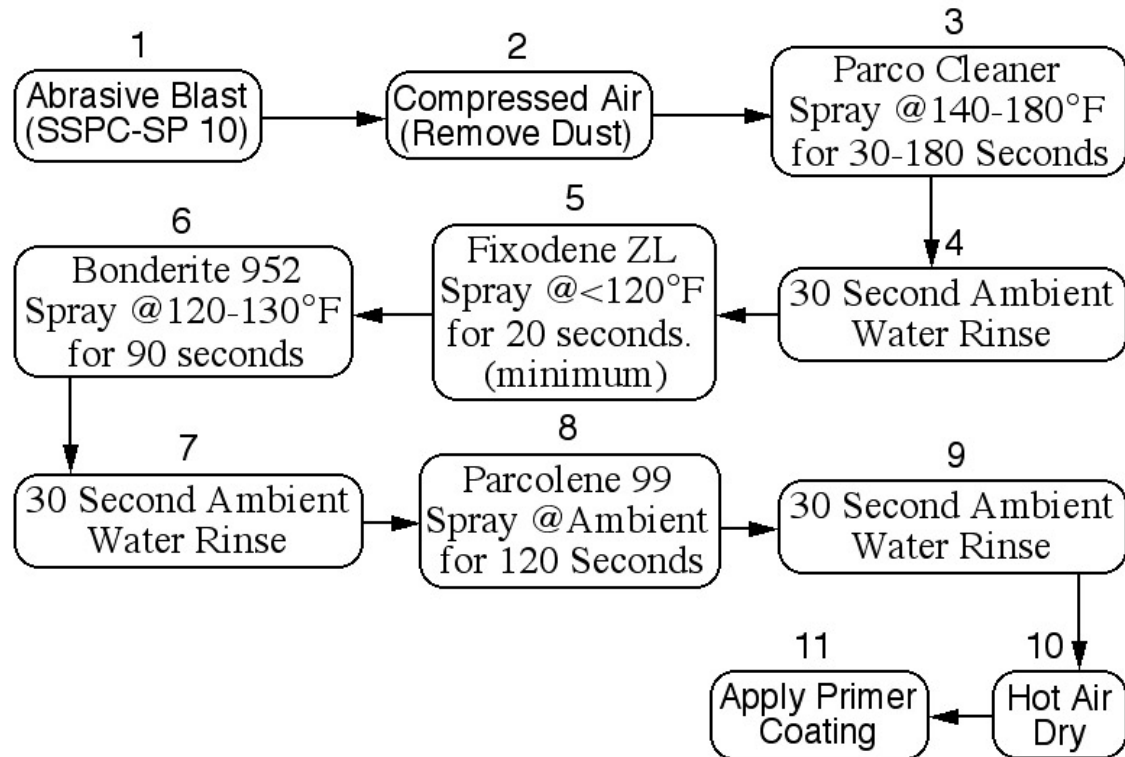

Figure 4. Process steps for the proposed spray zinc phosphate followed in the laboratory procedure.

Note: Fixodene and Parcolene are registered trademarks of Henkel Surface Technologies, Madison Heights, MI.



Figure 5. Test chamber configuration used for ASTM B 117-90 neutral salt fog.



Figure 6. Test chamber configuration used for GM 9540P cyclic corrosion.

Table 1. GM 9540P cyclic corrosion test details.

Interval	Description	Time (min)	Temperature (± 3 °C)
1	Ramp to salt mist	15	25
2	Salt mist cycle	1	25
3	Dry cycle	15	30
4	Ramp to salt mist	70	25
5	Salt mist cycle	1	25
6	Dry cycle	15	30
7	Ramp to salt mist	70	25
8	Salt mist cycle	1	25
9	Dry cycle	15	30
10	Ramp to salt mist	70	25
11	Salt mist cycle	1	25
12	Dry cycle	15	30
13	Ramp to humidity	15	49
14	Humidity cycle	480	49
15	Ramp to dry	15	60
16	Dry cycle	480	60
17	Ramp to ambient	15	25
18	Ambient cycle	480	25

In order to quantify the corrosion, ASTM B 117-90 salt fog panels were numerically rated for scribe corrosion creepback damage at weekly intervals up to 1512 hr using method ASTM D 1654-79A (20). The GM 9540P panels were also rated using ASTM D 1654-79A for scribe creepback corrosion at 10, 20, 40, 60, 70, and 80 cycles. In addition to the numeric ratings, representative panels chosen from the first exposure interval were digitally scanned at each rating interval and saved as high quality graphics files at 600 dpi to visually chronicle the corrosion damage. To facilitate easier viewing of the inevitable large quantities of raw data from this test matrix, color codes were assigned based upon ranges of ASTM D 1654-79A ratings. Table 2 depicts the ASTM D 1654-79A rating parameters and also defines the colors and their respective rating ranges. In addition to the color coding, for panels where coating blistering from corrosion occurred in areas away from the scribe, the numerical ratings appear boldfaced and underscored.

For evaluating coating adhesion to the different surface treatments, pull-off adhesion was chosen as the basis for adhesion evaluation over scribe and tape based methods such as ASTM D 3359 (21). Tape-based measurements were attempted, however, the coarse, irregular surface topography and extreme substrate hardness inherent to 46100 armor steel led to rapid dulling and even breaking of scribing tools as well as inconsistent and unusable results. The pull-off adhesion measurements assessing the effects of pretreatment or surface preparation at the substrate were performed in accordance with ASTM D 4541 (22). An Elcometer Model 108 hydraulic adhesion test equipment (HATE) was used for this procedure. In addition to being a more quantitative test method, pull-off adhesion is also less prone to human elements in testing, such as variations in pressure applied during scribing as well as interpretation and perception of results. For the pull-off adhesion test, a loading fixture commonly referred to as a “dolly” is

Table 2. Evaluation of scribed coated specimens subjected to corrosive environments - ASTM D 1654-79A.

Rating of Failure at Scribe (Procedure A)		
Representative Mean Creepage From Scribe		Rating Number
(mm)	(in)	
Over 0	0	10
Over 0 to 0.5	0 to 1/64	9
Over 0.5 to 1.0	1/64 to 1/32	8
Over 1.0 to 2.0	1/32 to 1/16	7
Over 2.0 to 3.0	1/16 to 1/8	6
Over 3.0 to 5.0	1/8 to 3/16	5
Over 5.0 to 7.0	3/16 to 1/4	4
Over 7.0 to 10.0	1/4 to 3/8	3
Over 10.0 to 13.0	3/8 to 1/2	2
Over 13.0 to 16.0	1/2 to 5/8	1
Over 16.0 to more	5/8 to more	0

secured normal to the coating surface using an adhesive. The adhesive used was cyanoacrylate. After allowing the adhesive to cure for 24 hr at 40 °C in dry conditions (table 3), the attached dolly was inserted into the test apparatus. The load applied by the apparatus was gradually increased and monitored on the gauge until a plug of coating was detached. The failure value (in psi) was recorded and the failure mode was characterized. The pull-off test apparatus and dolly configuration are illustrated in figure 7. For pull-off data to be valid, the specimen substrate must be of sufficient thickness to ensure that the coaxial load applied during the removal stage does not distort the substrate material and cause a bulging or “trampoline effect.” When a thin specimen is used, the resultant bulge causes the coating to radially peel away outwards from the center instead of being uniformly pulled away in pure tension and thus results in significantly lower readings than for identically prepared specimens at greater substrate thickness. At 0.25 in, all of the armor panels evaluated in the test matrix had adequate thickness for valid pull-off test results. Measurements were obtained by utilizing the five remaining specimens from each pretreatment coated with MIL-P-53022-10 (type II) primer with MIL-DTL-64159 (type II) topcoat except for the controls which used DOD-P-15328D and were coated with MIL-P-53022-10 (type I) primer and MIL-C-46168 topcoat. Pull-off adhesion measurements attempted with the MIL-C-53039A topcoated specimens all resulted in coating interlayer adhesive failures at the primer/ topcoat interface and thus could not be used to assess the relative effect on coating adhesion imparted by the pretreatment or surface preparation at the substrate. Any other failure measurements due to coating separation between the primer and topcoat layers or at the topcoat surface with the cyanoacrylate adhesive were also rejected.

In order to assess the relative resistance of pretreatment alternatives to flash rusting in a production environment, humidity testing was conducted on test panels prepared with only the surface preparation or pretreatment alternatives. Surplus panels from the adhesion study were abrasive blasted and prepared in four different configurations with five replicate panels for:

- Abrasive blast only.
- Abrasive blast with KLEENINHIB 486, sealed with CHEMINHIB 420.
- Abrasive blast and spray zinc phosphate (BONDERITE 952 w/Henkel clean stages).
- Abrasive blast with KLEENINHIB 486 and spray zinc phosphate (BONDERITE 952).

Table 3. Laboratory conditions for pull-off adhesion ASTM D 4541.

Adhesive Type	Cyanoacrylate
Cure time (hr)	24
Temperature (°C)	40
Percent relative humidity	~0
Substrate material	MIL-A-46100D
Substrate thickness (in)	0.25
Substrate surface profile	Abrasive blast (1.5 mil)
Pretreatment types	DOD-P-15328D None CHEMINHIB 420 Spray zinc phosphate
Coating types	CARC 53033(I)/46168 CARC 53022(II)/64159
Coating thickness (mils)	~5.5 (including profile)

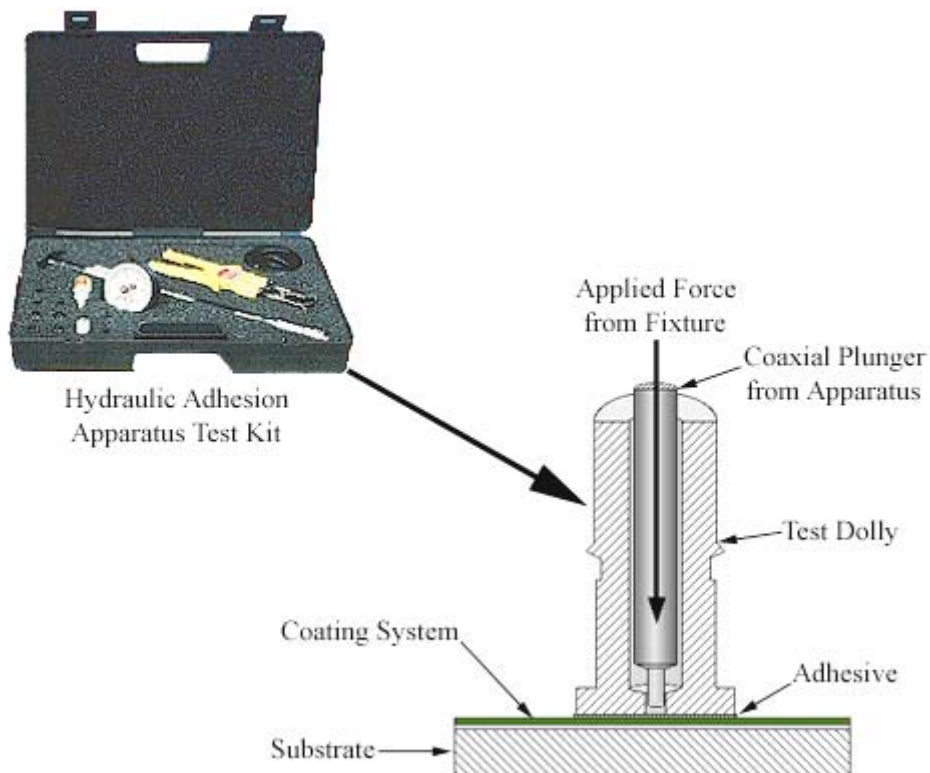

Figure 7. Pull-off hydraulic adhesion test (ASTM D 4541).

The humidity exposure was conducted in accordance with ASTM D 1735 (23) at saturated levels for 16 hr. Additional panels were also set aside in ambient laboratory conditions with relative humidity ranging from 60% to 70% for 1 week. For both exposures, the panels were digitally scanned prior to as well as after exposure.

Finally, resistance to environmentally assisted cracking was assessed using the rising step load method for determination of K_{IEAC} . For this procedure, CV2 Charpy specimens of MIL-A-46100D and VAR 4340 were machined in longitudinal-transverse (L-T) and transverse-longitudinal (T-L) orientations in accordance with ASTM E 399-97 (24, 25). Table 4 contains mechanical properties typical for these alloys and table 5 displays the composition specifications for MIL-A-46100D. The pretreatments evaluated for these specimens included: DOD-P-15328D wash primer, and spray zinc phosphate for the MIL-A-46100D steel and only spray zinc phosphate for the 4340 steel. Unlike the 46100 test panels, the charpy specimens were not abrasive blasted prior to pretreatment. The 4340 steel specimens were included for cross referencing of MIL-A-46100D to known materials. Specimen fatigue precracking was carried out using three stages, each consisting of decreasing loading levels. In the first precracking stage, the load was maintained to keep stress intensity values below 80% of the estimated experimental critical stress intensity and the stress ratio ($\sigma_{max}/\sigma_{min}$) was kept between -1 and $+0.1$. In the intermediate stage, the cycling load was reduced to maintain the stress intensity value as crack growth occurred and the intact cross section was reduced. For the final stage of precracking, the load was further reduced so the final value of K_{max} was unlikely to exceed 60% of the estimated value for K_I during experimentation. Additionally, the final value for K_{max}/E did not exceed $0.0032 \text{ m}^{1/2}$, where E is Young's modulus. Precrack length, represented by the dimensionless expression a/W (crack length over specimen width), was maintained near 0.5. The fatigue precrack loading sequences for the K_{IEAC} specimens are listed in table 6.

Table 4. Typical mechanical properties of MIL-A-46100D high hard armor and other high strength steels.

Mechanical Property	46100 HRc 48–51	VAR 4340 HRc 52–54	AISI 1095 HRc 48015050
UTS (MPa)	1825	1916	1696
0.2% YS (MPa)	1440	1572	1393
Elongation (%)	10	12.5	7.0
RA (%)	40	37.9	19.6

Specimens were then fastened into a double cantilever array test fixture under aqueous conditions with 3.5% NaCl solution at open circuit potential conditions. Specimens were loaded by incremental steps in accordance with ASTM F 1624-95 (26) using an Instron model 4301 hydraulic load frame apparatus. The specimen load values versus time were recorded via Labview interface to a computer data file. The calculation for the onset of environmentally assisted cracking, or K_{IEAC} , was derived as follows for cantilever bending from the four-point bending expression.

$$K_{IEAC} = \left(\frac{6M_{IEAC}\sqrt{\pi a}}{BW^2} \right) \times f(a/W) , \quad (1)$$

Table 5. Chemical composition of MIL-A-46100D high hard armor ^(a, b).

Element		Maximum Range Percent	Maximum Limit Percent
Carbon		0.1	0.32
Manganese	Up to 1.00 in include	0.3	—
	Over 1.00	0.4	—
Phosphorus		—	0.020 ^c
Sulfur		—	0.010 ^c
Silicon	Up to 0.60 in include	0.2	—
	Over 0.60 in to 1.00 in include	0.3	—
Nickel		0.5	—
Chromium	Up to 1.25 in include	0.3	—
	Over 1.25 in	0.4	—
Molybdenum	Up to 0.20 in include	0.07	—
	Over 0.20 in	0.15	—
Vanadium		0.15	—
Boron		—	— ^d
Copper		—	0.25 ^e
Titanium		—	0.10 ^e
Zirconium		—	0.10 ^e
Aluminum		—	0.10 ^e
Lead		—	0.01 ^e
Tin		—	0.02 ^e
Antimony		—	0.02 ^e
Arsenic		—	0.02 ^e

^a This table lists the maximum range for elements of the manufacturer's established chemical composition.

^b Elements not listed in this table, but intentionally added, shall be reported.

^c Phosphorus and sulfur should be controlled to the lowest attainable levels but, in no case, should the combined phosphorus and sulfur content exceed 0.025%.

^d When the amount of boron is specified in the alloy, its content so determined by heat analysis shall not exceed 0.003%.

^e When the amount of an element is less than 0.02% the analysis may be reported as 0.02%.

where

$$f(a/W) = 1.122 - 1.40(a/W) + 7.33(a/W)^2 - 13.08(a/W)^3 + 14.00(a/W)^4, \quad (2)$$

where

- M_{IEAC} = the applied moment necessary to induced cracking,
- B = the specimen thickness,
- W = the specimen depth, and
- a = the initial crack length.

For double cantilever bending conditions, the term M_{IEAC} becomes P_{IEAC} , where P_{IEAC} is the load necessary to induce critical cracking and S is the length of the moment arm. This yields the utilized expression:

Table 6. Precracking conditions for K^{IEAC} CV2 specimens.

Sample ID	Precrack Load (lb)	Number of Cycles	Precrack Length Side 1/Side 2 (in)	Average Crack Length "a" (in)
715037	1200	14000	0.098/0.113	0.1820
	800	9000	0.119/0.125	
	600	37000	0.183/0.181	
715038	1200	13000	0.105/0.101	0.1810
	800	9000	0.121/0.117	
	600	43000	0.181/0.181	
715042	1200	26000	0.118/0.100	0.1815
	800	10000	0.134/0.125	
	600	37000	0.182/0.181	
715043	1200	29000	0.134/0.104	0.1865
	800	10000	0.148/0.125	
	600	38000	0.193/0.180	
715047	1200	14000	0.103/0.108	0.1865
	800	12000	0.121/0.127	
	600	49000	0.184/0.189	
715048	1200	14000	0.093/0.115	0.1840
	800	11000	0.115/0.132	
	600	47000	0.180/0.188	
715051	1200	20000	0.109/0.102	0.1865
	800	16000	0.125/0.129	
	600	53000	0.181/0.185	
715052	1200	20000	0.105/0.105	0.1830
	800	18000	0.127/0.127	
	600	44000	0.181/0.183	
715053	1200	22000	0.118/0.088	0.1820
	800	14000	0.137/0.111	
	600	56000	0.200/0.176	
715054	1200	21000	0.098/0.113	0.1880
	800	15000	0.098/0.113	
	600	70953	0.098/0.113	
715057	1200	21000	0.115/0.111	0.1885
	800	12000	0.141/0.141	
	600	16000	0.186/0.191	
715064	1200	16000	0.107/0.103	0.1875
	800	10000	0.122/0.124	
	600	29000	0.187/0.188	

$$K_{IEAC} = \left(\frac{6P_{IEAC} S \sqrt{\pi a}}{BW^2} \right) \times f(a/W), \quad (3)$$

where $f(a/W)$ varies between 2.3 and 3.2 for a/W values between 0.45 and 0.55, respectively (27, 28).

The initial crack length was determined by averaging the measured values visible on each side of the charpy specimen that ran perpendicular to the crack front. The K_{IEAC} values calculated were compared among the pretreatments and against historic values measured for untreated high hard steel to determine whether any pretreatment degraded the material and exacerbated

environmentally assisted cracking (29, 30). The dimensions for the CV2 specimens, their orientations with respect to the major axis' of the rolled armor plate, and the configuration of the rising step load equipment are shown in figures 8–12.

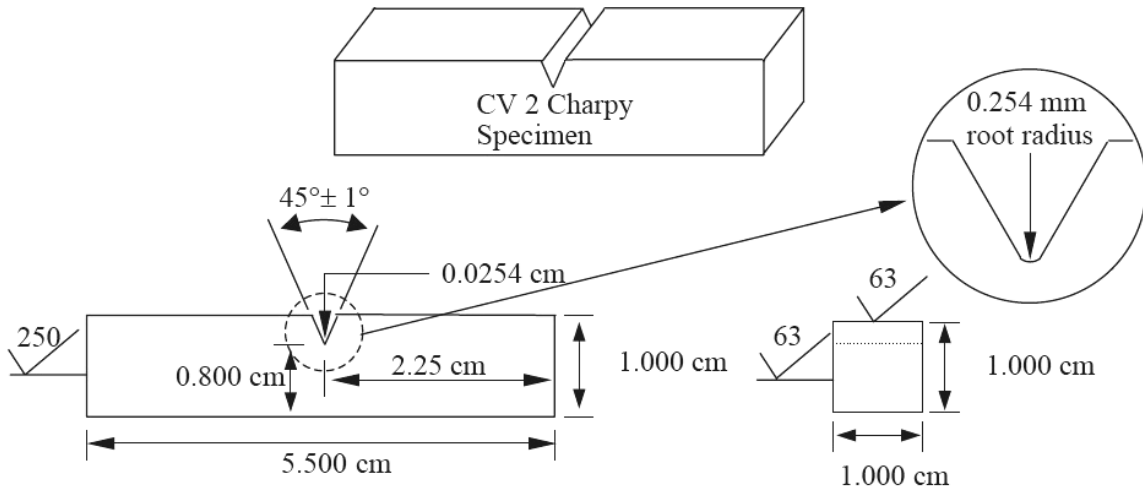

Notes:

1. Tolerances, unless noted.
- Squareness ⊥ perpendicular ± 0.001 TIR
 || parallel ± 0.001 TIR
- Decimal .XX ± 0.127 mm
 .XXX ± 0.0254 mm
 .XXXX ± 0.0127 mm

Figure 8. K_{IEAC} test specimen configuration (25).

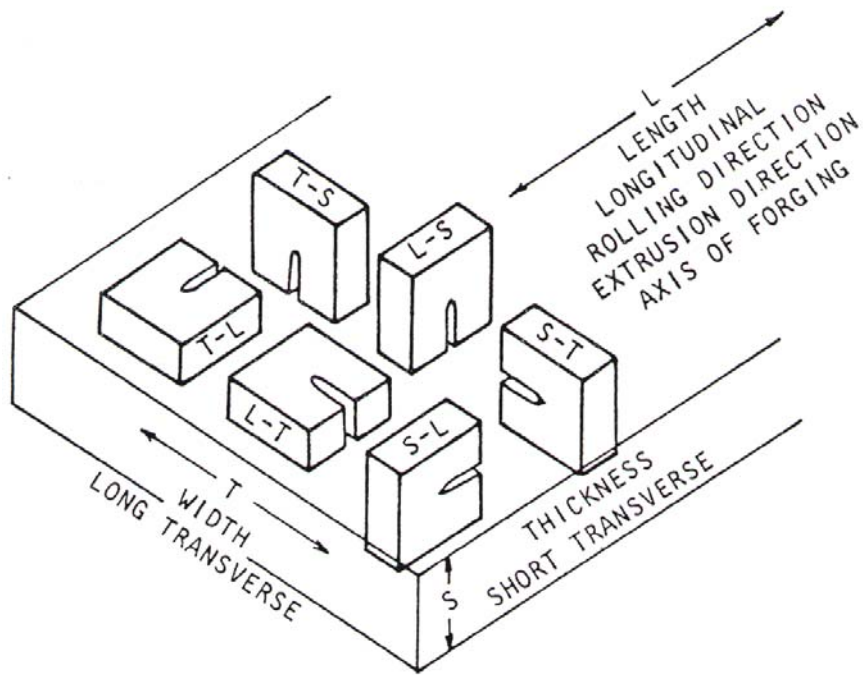

Figure 9. Crack plane orientation identification codes for rolled plate (24).

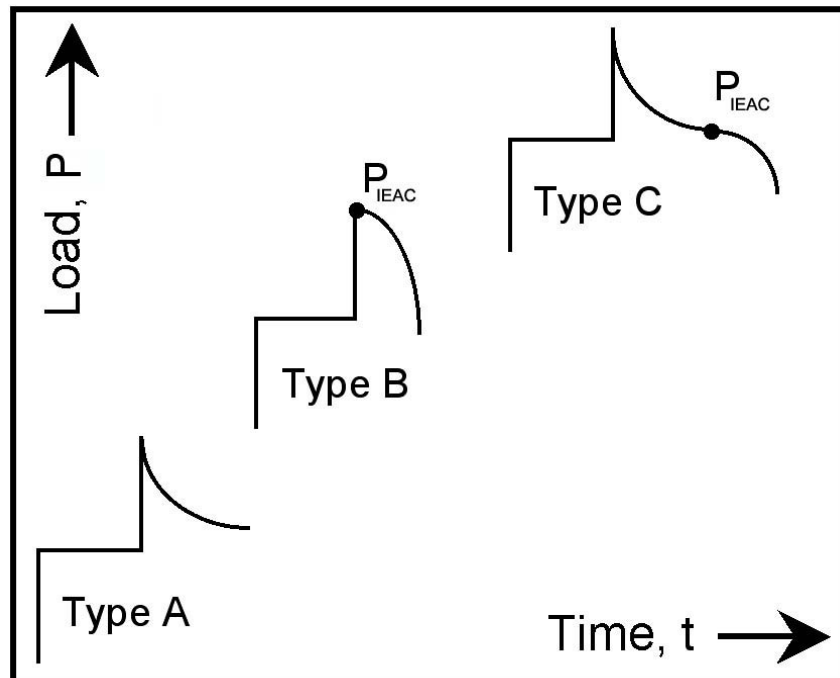

Figure 10. Identification of crack initiation load P_{IEAC} .

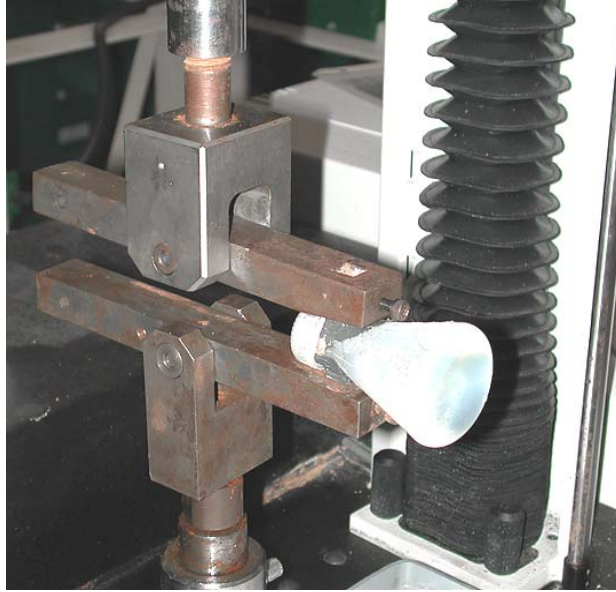

Figure 11. Rising step load specimen in test fixture.



Figure 12. Rising step load test configuration.

3. Results

3.1 Pull-off Adhesion

With the exception of specimens pretreated with DOD-P-15328D wash primer, all of the surface pretreatments showed consistent repeatable readings for adhesion data collected and plotted in figures 13–16 and listed in table 7. As mentioned in the procedure, the readings for abrasive blast, abrasive blast with CHEMINHIB 420, and spray zinc phosphate, were all collected from panels coated with MIL-P-53022-10 (type II) primer and MIL-DTL-64159 waterborne topcoat. Pull-off readings were attempted on the MIL-C-53039A coated specimens however the pull-off separations all occurred consistently in the 2200–2500 psi range as adhesive separations *between* the MIL-P-53022-10 (type II) primer and the MIL-C-53039A topcoat and were thus not applicable for evaluation of pretreatment effects on adhesion. Abrasive blast and abrasive blast prepared with CHEMINHIB 420 water soluble flash rust inhibiting coating, the two procedures currently used at GDLS for Stryker production in particular had very tightly grouped data and both averaged within 100 psi of each other at 3411 psi and 3494 psi respectively. For spray zinc phosphate pretreated panels the average pull-off adhesion reading was 3304 psi, down roughly 150 psi from the average readings from panels prepared with abrasive blast and abrasive blast with CHEMINHIB 420. All of the current and proposed pretreatments had significantly better adhesion performance than the legacy system consisting of DOD 1538 wash primer with MIL-P-53022-10 (type I) primer with MIL-C-46168D two component solvent-borne topcoat. The increases ranged from 16% for spray zinc phosphate to 21% for abrasive blast with CHEMINHIB 420 over the wash primer baseline average pull-off adhesion value of 2775 psi.

3.2 Accelerated Corrosion

For all of the panels exposed in ASTM-B-117-90 neutral salt fog and GM 9540P, the dominant failure mode was creepback from the scribe via blistering as rated under ASTM-D-1654-79A. In addition to the creepback rating, severity color coding described in table 2, additional corrosion characterization such as blistering away from the scribe was illustrated through application of diagonal cross-hatching texture to the color coded cells.

For neutral salt fog testing, many of the panels, especially the abrasive blast and the abrasive blast with CHEMINHIB 420 panels, had secondary blistering away from the scribed areas. For these panels, onset exposures for the nonscribe blistering occurred at 500 and 1176 hr, respectively, for the waterborne and solvent-borne topcoated specimens. Interestingly, despite poorer performance for nonscribe areas, scribe creepback ratings for waterborne topcoated abrasive blast, and abrasive blast with CHEMINHIB 420 were slightly improved vs. their solventborne counterparts. The spray zinc phosphate and wash primer treated panels had much

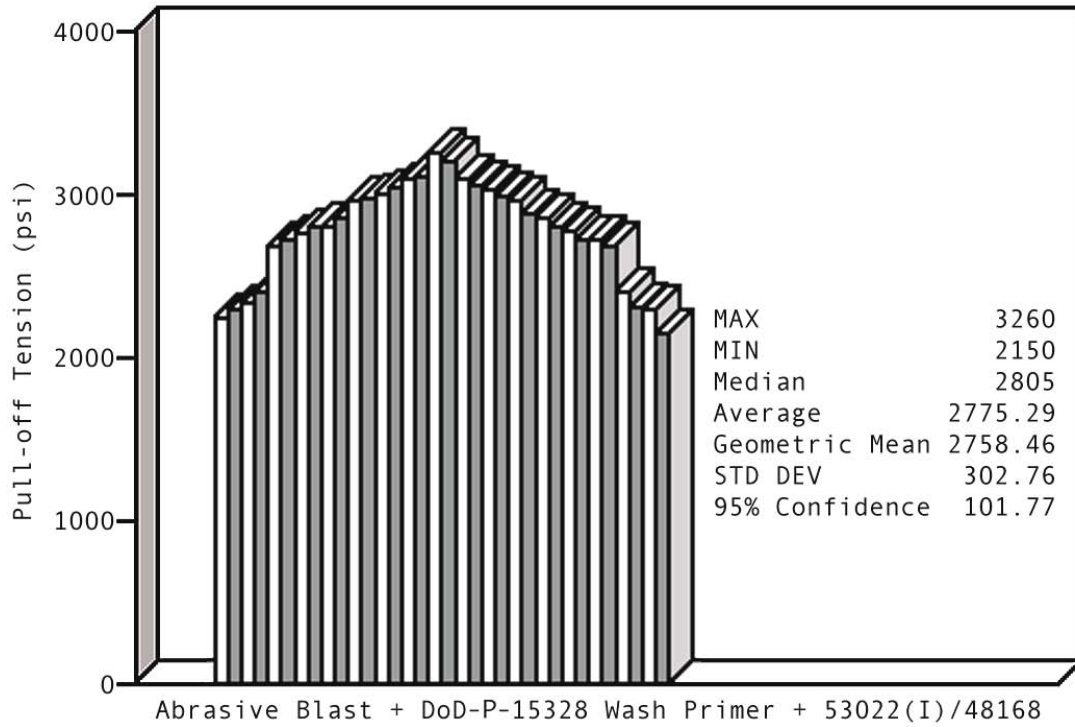

Figure 13. ASTM D 4541 pull-off adhesion results abrasive blast with DOD-P-15328D (wash primer) Cr⁺⁶ based legacy pretreatment.

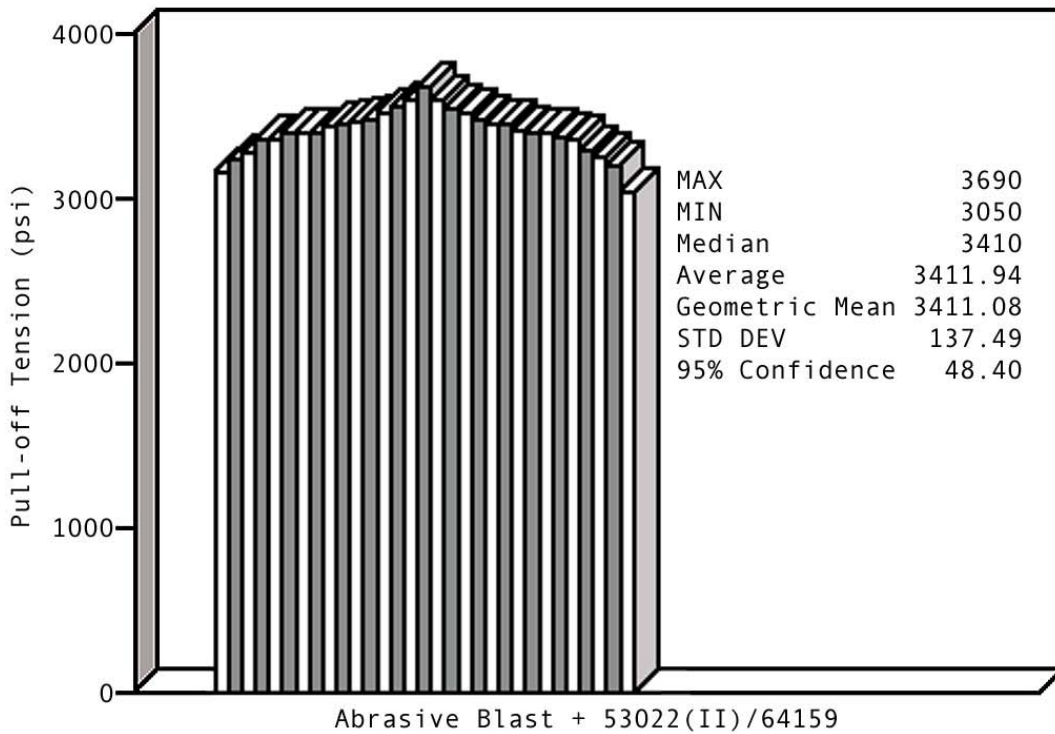

Figure 14. ASTM D 4541 pull-off adhesion results for abrasive blast only.

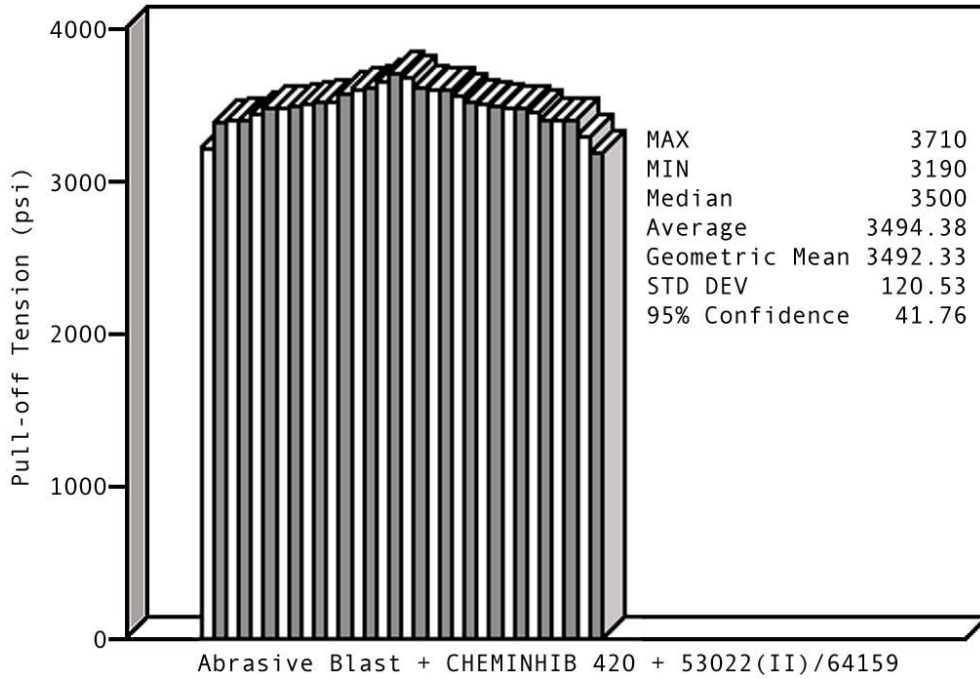

Figure 15. ASTM D 4541 pull-off adhesion results for abrasive blast with CHEMINHIB 420 water soluble inhibitor coating.

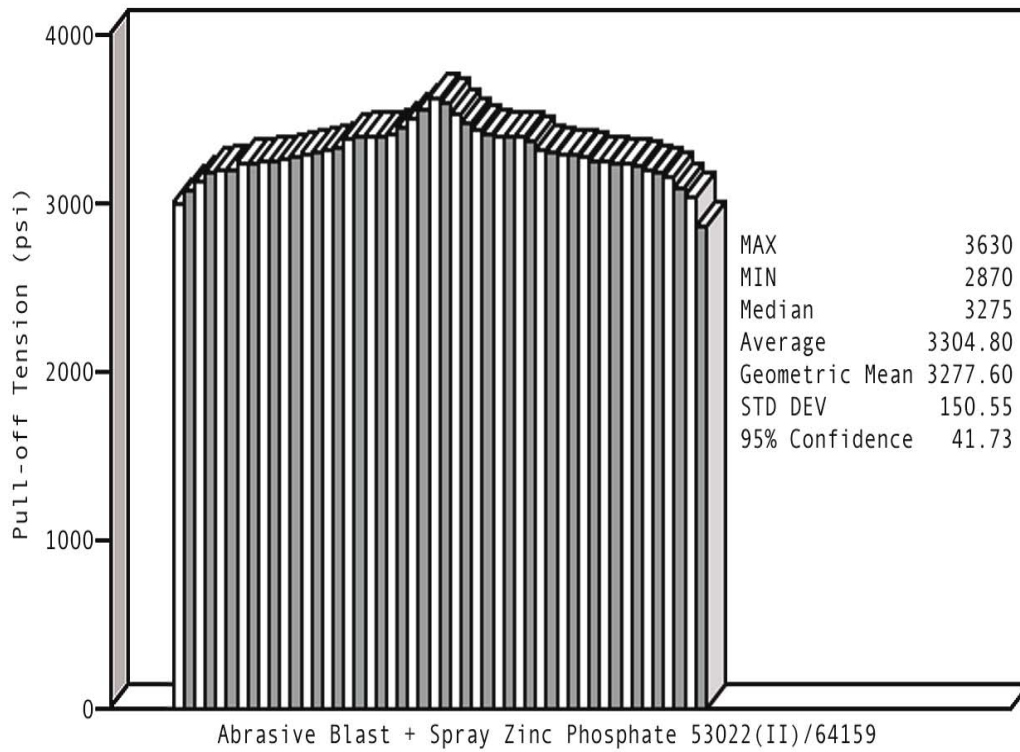

Figure 16. ASTM D 4541 pull-off adhesion results for abrasive blast with spray zinc phosphate pretreatment.

Table 7. Readings (psi) for ASTM D 4541 pull-off adhesion.

Abrasive Blast (None) 53022(II)/64159	CHEMINHIB 420 53022(II)/64159	Spray Zinc Phosphate 53022(II)/64159	DOD-P-15328D (Wash Primer) 53022(I)/46168
3260	3500	3250	2400
3380	3500	3400	2400
3460	3460	3450	2150
3610	3410	3400	2770
3520	3570	3260	2980
3410	3510	3300	2720
3300	3600	3200	3040
3200	3520	3310	3000
3470	3410	3460	2300
3460	3520	3610	3200
3440	3600	3090	2860
3410	3680	3400	2800
3400	3620	3540	2970
3370	3510	3390	2990
3360	3660	3240	2810
3550	3580	3380	3100
3570	3450	3410	2720
3420	3490	3400	2780
3400	3480	3000	2890
3290	3610	3240	2720
3170	3520	3420	2340
3460	3620	3160	2250
3480	3490	3260	3110
3610	3400	3240	2310
3240	3410	3310	2300
3050	3400	3410	3060
3490	3220	3320	2960
3520	3190	3200	2800
3410	3300	3260	2690
3370	3490	3050	3030
3690	3390	3300	3260
—	3710	3560	2860
—	—	3140	3100
—	—	3230	2690
—	—	3270	—
—	—	3630	—
—	—	3200	—
—	—	3300	—
—	—	3510	—
—	—	3480	—
—	—	3280	—
—	—	3420	—
—	—	3190	—
—	—	3100	—
—	—	3290	—
—	—	3340	—
—	—	3190	—
—	—	3260	—
—	—	2870	—
—	—	3320	—

Note: All pull-off separation modes were adhesive at the substrate.

better performance, only two of the waterborne topcoated zinc phosphate had any blistering away from the scribe, the solvent-borne topcoated zinc phosphated panels and all of the wash primer treated panels remained blister free in the nonscribe areas through 1500 hr. For blistering at the scribe, the wash primer panels fared no better than abrasive blast or abrasive blast with CHEMINHIB 420. When evaluating the neutral salt fog panels for overall performance, in scribed and nonscribed areas, the vast majority of spray zinc phosphated panels performed better than or equal to the other pretreatments across all replicates. Table 8 displays the ratings at various exposures and characterizes the corrosion using the color coding and patterns described above. Digital photographs comparing the pretreatments with waterborne and solventborne topcoats and also the legacy system with DOD-P-15328D and MIL-C-46168 at 1500 hr are displayed in figures 17–19.

The performance gains noted in neutral salt fog exposure for spray zinc phosphate were even more pronounced in GM 9540P cyclic exposure. Spray zinc phosphate scribe creepback ratings showed roughly a 2:1 improvement in performance ratio throughout the eighty cycle duration vs. abrasive blast and abrasive blast with CHEMINHIB 420. None of the panels tested in GM 9540P exhibited blistering away from the scribe. In contrast to salt fog, no significant differences were observed between waterborne and solvent-borne topcoated panels. Cyclic corrosion performance at 80 cycles for DOD-P-15328D wash primer was inconsistent with some of the replicate panels performing very well while others rated low or failed completely due to excessive blister growth from the scribed region. The improvement in scribe creepback corrosion performance gained using the spray zinc phosphating is visible in table 9 and is apparent across all of the exposure intervals. As in neutral salt fog, digital photographs comparing the pretreatments with waterborne and solvent-borne topcoats and also the legacy system with DOD-P-15328D and MIL-C-46168 at 80 cycles are displayed in figures 20–22.

3.3 Resistance to Flash Rusting

In order to assess pretreatments from a production perspective, the three main test pretreatments (abrasive blast, abrasive blast with CHEMINHIB 420, and spray zinc phosphate) were applied to the 46100 steel and exposed without primer and topcoat to ambient laboratory conditions at 27 °C with relative humidity ranging from 60 to 70% and to ASTM-D-1735 at 35 °C with 100% relative humidity. One additional hybrid set of panels was prepared using the KLEENINHIB 486 process which is the surface cleaning step used for CHEMINHIB 420 but was then spray zinc phosphated using the BONDERITE 952 with the PARCOLENE 99 rinse thus effectively substituting the existing production cleaning step for the Henkel surface prep stages. Before and after exposure scans of the treatments are pictured in figures 23–26. The initial surfaces showed almost no difference in appearance between the abrasive blast and abrasive blast with CHEMINHIB 420 prepared panels. The spray zinc phosphate and spray zinc phosphate cleaned with KLEENINHIB 486 both showed effective deposition of the zinc phosphate crystals however, there was also noticeable flash rusting present on the KLEENINHIB 486 cleaned spray zinc phosphate panels. Panels exposed in 16 hr at 100% RH show rusting on all of the pretreated

Table 8. ASTM D 1654-79A scribe creepback ratings for 1500 hr ASTM B 117-90 salt fog exposure.

Panel #	Pretreatment	Primer/Topcoat	144 Hours	336 Hours	500 Hours	672 Hours	840 Hours	1008 Hours	1176 Hours	1344 Hours	1512 Hours
GB1s	Gritblast	53022(II)/53039	9	9	7	5	4	4	3	<u>2</u>	<u>2</u>
GB2s	Gritblast	53022(II)/53039	9	8	7	5	4	3	3	<u>2</u>	<u>2</u>
GB3s	Gritblast	53022(II)/53039	9	9	6	5	5	4	4	4	3
GB4s	Gritblast	53022(II)/53039	9	9	5	5	4	4	<u>3</u>	<u>3</u>	<u>3</u>
GB5s	Gritblast	53022(II)/53039	9	8	6	5	5	4	<u>4</u>	<u>3</u>	<u>3</u>
GB1w	Gritblast	53022(II)/64159	9	7	6	6	5	4	4	<u>3</u>	<u>3</u>
GB2w	Gritblast	53022(II)/64159	9	8	7	6	4	4	4	4	4
GB3w	Gritblast	53022(II)/64159	9	9	6	6	6	5	5	5	5
GB4w	Gritblast	53022(II)/64159	9	7	7	<u>5</u>	<u>5</u>	<u>5</u>	<u>5</u>	<u>4</u>	<u>4</u>
GB5w	Gritblast	53022(II)/64159	9	8	6	<u>5</u>	<u>4</u>	<u>3</u>	<u>3</u>	<u>3</u>	<u>3</u>
P1s	Spray Zn Phosphate	53022(II)/53039	9	8	6	6	5	5	5	4	4
P2s	Spray Zn Phosphate	53022(II)/53039	9	8	7	6	5	5	5	5	5
P3s	Spray Zn Phosphate	53022(II)/53039	9	8	7	6	6	5	5	5	4
P4s	Spray Zn Phosphate	53022(II)/53039	9	9	6	5	5	4	4	4	4
P5s	Spray Zn Phosphate	53022(II)/53039	9	8	7	6	5	5	4	4	3
P1w	Spray Zn Phosphate	53022(II)/64159	9	7	7	6	6	<u>5</u>	<u>4</u>	<u>4</u>	<u>4</u>
P2w	Spray Zn Phosphate	53022(II)/64159	9	8	6	5	5	5	5	5	5
P3w	Spray Zn Phosphate	53022(II)/64159	9	6	6	6	6	5	5	4	4
P4w	Spray Zn Phosphate	53022(II)/64159	9	8	6	6	5	5	5	5	5
P5w	Spray Zn Phosphate	53022(II)/64159	9	8	6	6	<u>5</u>	<u>4</u>	<u>4</u>	<u>4</u>	<u>4</u>
C1s	Cheminhib 420	53022(II)/53039	9	8	6	5	4	3	3	3	3
C2s	Cheminhib 420	53022(II)/53039	9	9	5	5	5	4	4	3	3
C3s	Cheminhib 420	53022(II)/53039	9	9	7	5	4	2	2	2	1
C4s	Cheminhib 420	53022(II)/53039	9	7	7	5	4	4	3	<u>3</u>	<u>3</u>
C5s	Cheminhib 420	53022(II)/53039	9	9	7	4	4	3	3	<u>3</u>	<u>3</u>
C1w	Cheminhib 420	53022(II)/64159	9	8	7	5	5	4	4	3	2
C2w	Cheminhib 420	53022(II)/64159	9	9	7	5	5	4	4	4	3
C3w	Cheminhib 420	53022(II)/64159	9	8	7	6	5	5	4	4	4
C4w	Cheminhib 420	53022(II)/64159	9	9	6	5	5	4	4	3	3
C5w	Cheminhib 420	53022(II)/64159	9	8	7	<u>5</u>	<u>5</u>	<u>5</u>	<u>4</u>	<u>4</u>	<u>4</u>
WP1	DoD-P-15328	53022(I)/46168	No Data	No Data	No Data	No Data	No Data	No Data	No Data	No Data	3
WP2	DoD-P-15328	53022(I)/46168	No Data	7	4	3	3	3	3	3	2
WP3	DoD-P-15328	53022(I)/46168	No Data	No Data	No Data	No Data	No Data	No Data	No Data	No Data	2
WP4	DoD-P-15328	53022(I)/46168	No Data	No Data	No Data	No Data	No Data	No Data	No Data	No Data	3
WP5	DoD-P-15328	53022(I)/46168	No Data	No Data	No Data	No Data	No Data	No Data	No Data	No Data	3

Note: Boldfaced and underscored ratings denote coating blistering in areas away from the scribe.



(a) Abrasive Blast

(b) Abrasive Blast + CHEMINHIB 420

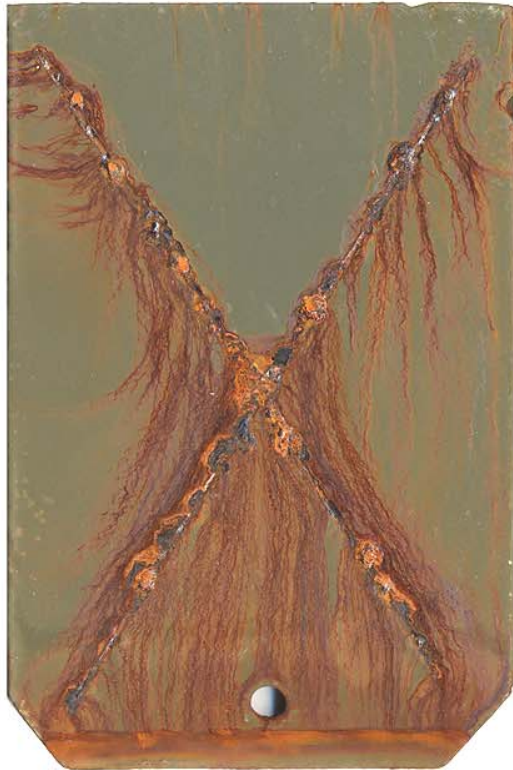

(c) Abrasive Blast + Spray Zinc Phosphate

Figure 17. 53022(II)/53039A at 1500 hr ASTM B 117-90 salt fog.



(a) Abrasive Blast



(b) Abrasive Blast + CHEMINHIB 420



(c) Abrasive Blast + Spray Zinc Phosphate

Figure 18. 53022(II)/64159 at 1500 hr ASTM B 117-90 salt fog.



(a) DoD-P-15328 53022(I)/46168



(b) Spray Zinc Phosphate 53022(II)/53039

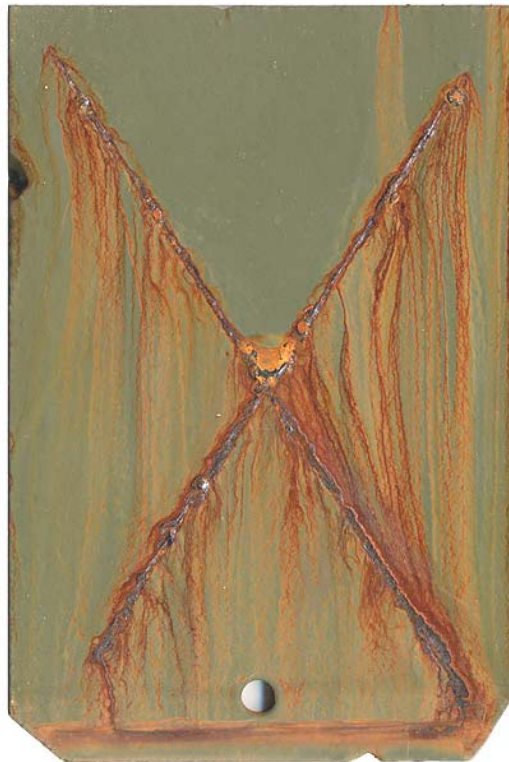

(c) Spray Zinc Phosphate 53022(II)/64159

Figure 19. Legacy coating system (a) vs. current coating systems (b and c) pretreated with spray zinc phosphate at 1500 hr ASTM B 117-90 salt fog.

Table 9. ASTM D 1654-79A scribe creepback ratings for 80 cycle GM 9540P cyclic corrosion exposure.

Panel #	Pretreatment	Primer/Topcoat	10 Cycles	20 Cycles	40 Cycles	60 Cycles	70 Cycles	80 Cycles
GB1s	Gritblast	53022(II)/53039	7	4	2	0	0	0
GB2s	Gritblast	53022(II)/53039	7	4	3	2	2	1
GB3s	Gritblast	53022(II)/53039	7	3	2	1	1	0
GB4s	Gritblast	53022(II)/53039	6	4	2	0	0	0
GB5s	Gritblast	53022(II)/53039	6	3	2	1	0	0
GB1w	Gritblast	53022(II)/64159	6	4	2	2	2	1
GB2w	Gritblast	53022(II)/64159	6	3	2	0	0	0
GB3w	Gritblast	53022(II)/64159	6	4	2	0	0	0
GB4w	Gritblast	53022(II)/64159	7	3	1	1	0	0
GB5w	Gritblast	53022(II)/64159	5	3	3	1	1	0
P1s	Spray Zn Phosphate	53022(II)/53039	9	6	5	3	2	2
P2s	Spray Zn Phosphate	53022(II)/53039	9	6	4	3	3	2
P3s	Spray Zn Phosphate	53022(II)/53039	9	5	4	2	2	1
P4s	Spray Zn Phosphate	53022(II)/53039	9	5	4	3	3	3
P5s	Spray Zn Phosphate	53022(II)/53039	8	6	4	3	3	3
P1w	Spray Zn Phosphate	53022(II)/64159	9	5	3	2	2	2
P2w	Spray Zn Phosphate	53022(II)/64159	9	5	3	2	2	2
P3w	Spray Zn Phosphate	53022(II)/64159	9	6	4	2	2	2
P4w	Spray Zn Phosphate	53022(II)/64159	9	6	4	3	3	3
P5w	Spray Zn Phosphate	53022(II)/64159	8	7	5	3	3	3
C1s	Chemihib 420	53022(II)/53039	7	4	3	1	1	0
C2s	Chemihib 420	53022(II)/53039	7	4	2	1	1	0
C3s	Chemihib 420	53022(II)/53039	6	4	2	1	0	0
C4s	Chemihib 420	53022(II)/53039	5	4	3	2	2	1
C5s	Chemihib 420	53022(II)/53039	6	3	2	0	0	0
C1w	Chemihib 420	53022(II)/64159	6	4	0	0	0	0
C2w	Chemihib 420	53022(II)/64159	5	4	3	2	2	0
C3w	Chemihib 420	53022(II)/64159	6	5	3	2	0	0
C4w	Chemihib 420	53022(II)/64159	6	3	2	2	0	0
C5w	Chemihib 420	53022(II)/64159	6	4	3	1	1	0
WP1	DoD-P-15328	53022(I)/46168	No Data	No Data	No Data	No Data	No Data	5
WP2	DoD-P-15328	53022(I)/46168	No Data	No Data	No Data	No Data	No Data	5
WP3	DoD-P-15328	53022(I)/46168	No Data	No Data	No Data	No Data	No Data	2
WP4	DoD-P-15328	53022(I)/46168	7	6	2	2	No Data	0
WP5	DoD-P-15328	53022(I)/46168	No Data	No Data	No Data	No Data	No Data	3



(a) Abrasive Blast



(b) Abrasive Blast + CHEMINHIB 420



(c) Abrasive Blast + Spray Zinc Phosphate

Figure 20. 53022(II)/53039A at 80 cycles GM 9540P cyclic corrosion.



(a) Abrasive Blast



(b) Abrasive Blast + CHEMINHIB 420



(c) Abrasive Blast + Spray Zinc Phosphate

Figure 21. 53022(II)/64159 at 80 cycles GM 9540P cyclic corrosion.

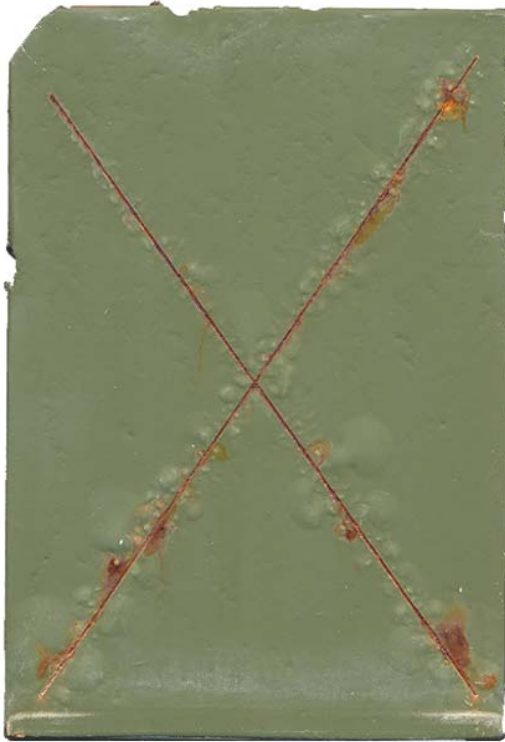

(a) DoD-P-15328 53022(I)/46168



(b) Spray Zinc Phosphate 53022(II)/53039



(c) Spray Zinc Phosphate 53022(II)/64159

Figure 22. Legacy coating system (a) vs. current coating systems (b and c) pretreated with spray zinc phosphate at 80 cycles GM 9540P cyclic corrosion.

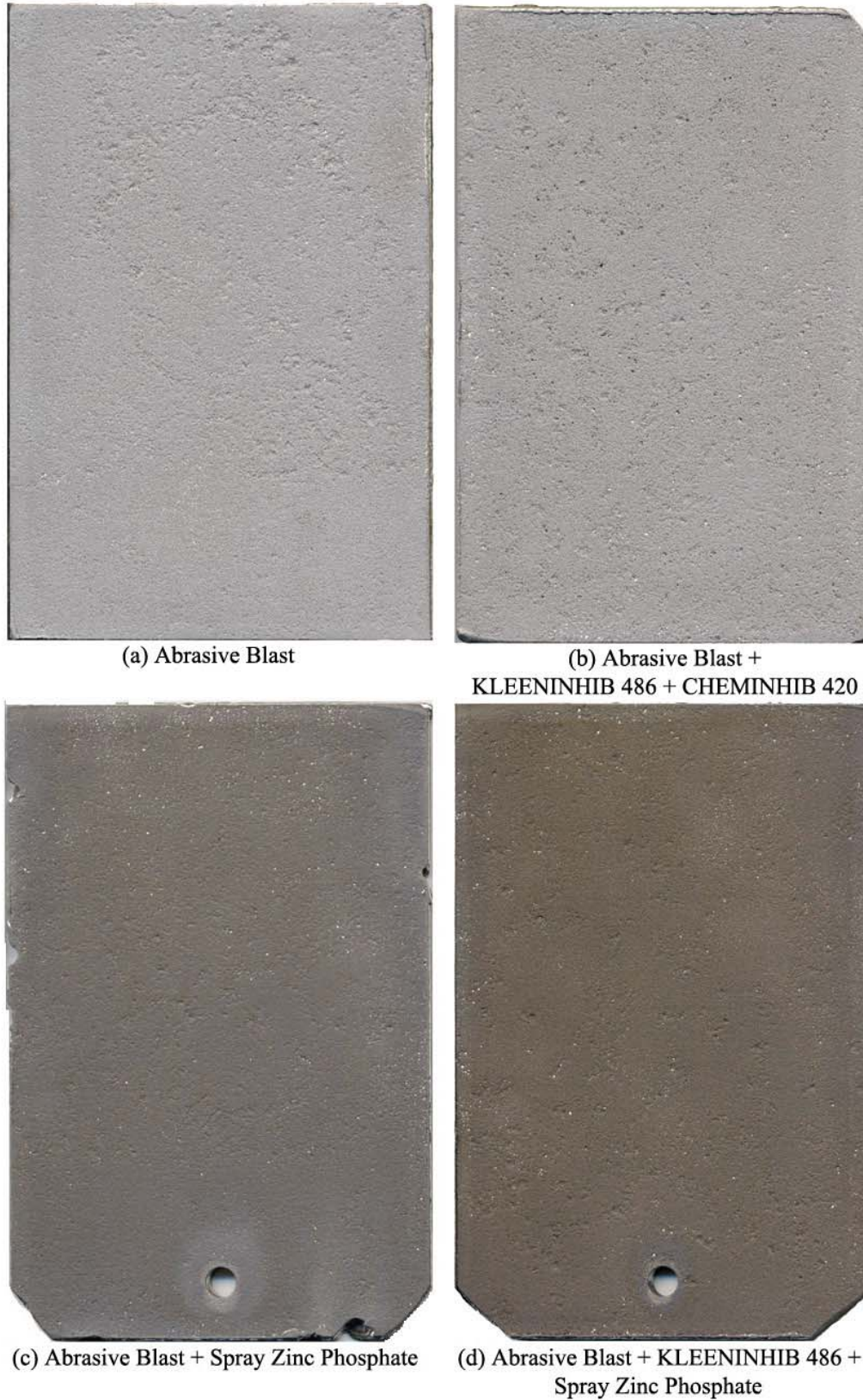

Figure 23. Initial appearance of bare pretreated specimens prior to 100% relative humidity exposure.



(a) Abrasive Blast



(b) Abrasive Blast +
KLEENINHIB 486 + CHEMINHIB 420



(c) Abrasive Blast + Spray Zinc Phosphate



(d) Abrasive Blast + KLEENINHIB 486 +
Spray Zinc Phosphate

Figure 24. Appearance of bare pretreated specimens after 16 hr of ASTM D 1735 100% relative humidity exposure.



(a) Abrasive Blast



(b) Abrasive Blast +
KLEENINHIB 486 + CHEMINHIB 420

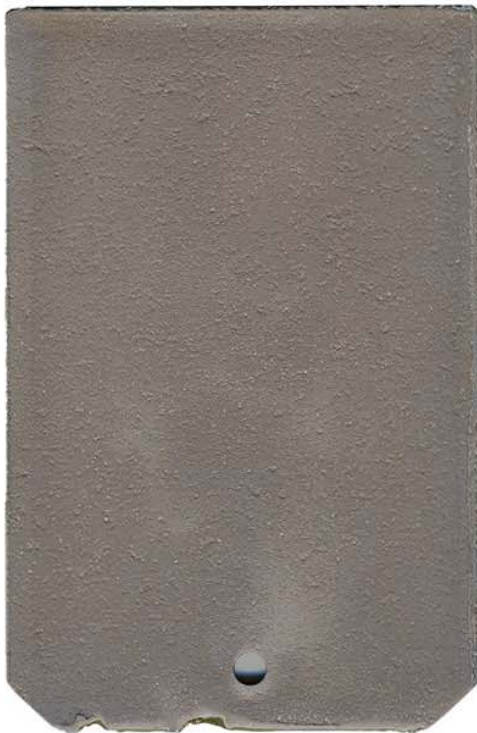

(c) Abrasive Blast + Spray Zinc Phosphate

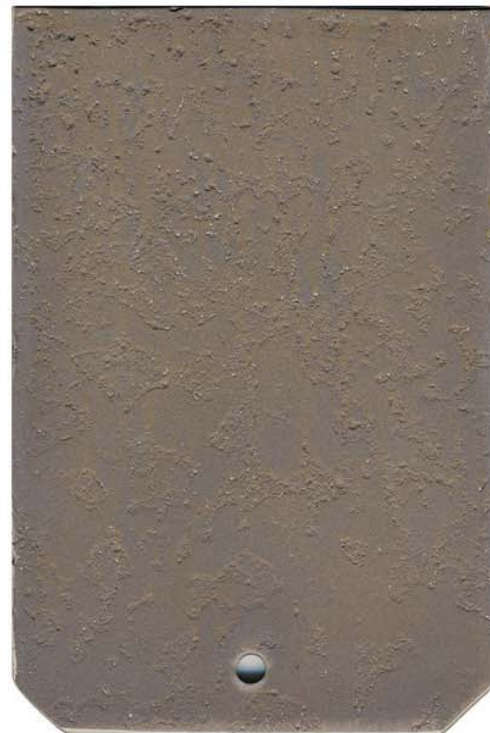

(d) Abrasive Blast + KLEENINHIB 486 +
Spray Zinc Phosphate

Figure 25. Initial appearance of bare pretreated specimens prior to 1 week of 27 °C, 69% relative humidity ambient laboratory exposure.



(a) Abrasive Blast



(b) Abrasive Blast +
KLEENINHIB 486 + CHEMINHIB 420

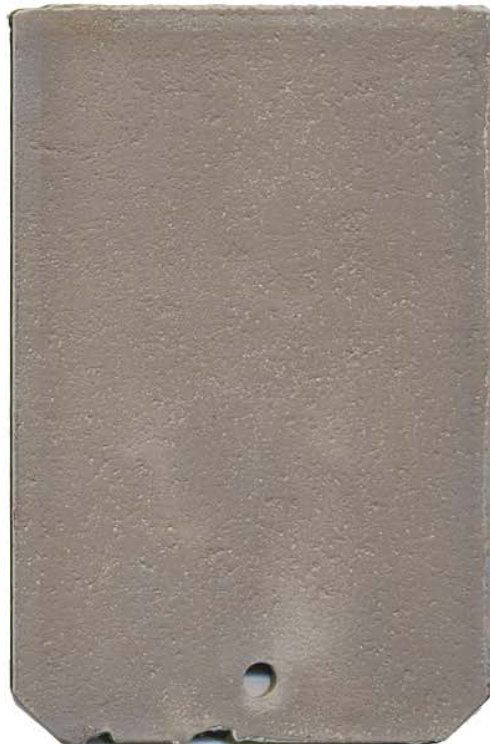

(c) Abrasive Blast + Spray Zinc Phosphate



(d) Abrasive Blast + KLEENINHIB 486 +
Spray Zinc Phosphate

Figure 26. Appearance of bare pretreated specimens after 1 week of 27 °C, 69% relative humidity ambient laboratory exposure.

panels. Of these panels, the CHEMINHIB 420 treated abrasive blast panels had the least amount of rusting among the four surface pretreatments with most of the rusting occurring within the surface pores commonly found on 46100 steel. Surprisingly, despite the initial head start in flash rust, there was less rusting present on the KLEENINHIB 486 prepared spray zinc phosphate panels after 16 hr vs. the standard Henkel-cleaned spray zinc phosphate panels. For the laboratory-exposed panels, there was no significant visible damage to any panels except for the panels prepared with only abrasive blast that only showed localized flash rusting.

3.4 Rising Step Load (K_{IEAC})

Figure 27 shows the average K_{IEAC} value for each alloy/pretreatment configuration plotted with respect to notch orientation. The complete listing of all K_{IEAC} values, details, and the crack initiation loads are listed in table 10. It can be seen that experimental results fall within the historic ranges of the respective alloys without a protective pretreatment. As expected, MIL-A-46100D performed better than the VAR 4340. It was also expected that, for all samples tested, L-T orientations would be more resistant to environmentally assisted cracking than T-L orientations. While the L-T wash primer 46100 samples had a highest average K_{IEAC} , it was only 5% higher than its T-L counterpart. Moreover, the reverse was true of the phosphated 46100 where the K_{IEAC} for the T-L orientation was 4% higher than the L-T. These results show no clear trend to confirm that either orientation is more resistant to EAC than the other. In addition, there is no evidence to suggest that either spray zinc phosphate or DOD-P-15328D wash primer had an adverse influence on the K_{IEAC} of either 46100 or 4340.

4. Discussion

The goal of this study was to investigate alternative pretreatments for hexavalent chromium based DOD-P-15328D wash primer. Due to the less aggressive nature of the current GDLS surface preparations, most of the discussion will concern the proposed spray zinc phosphate process. It is the aqueous nature of the spray zinc phosphate application process that provides questions as to the possible risk for EAC. During early production of the U.S. Marine Corps Light Armored Vehicle (LAV) at the London, Ontario facility (formerly GM Defense) that is the current site for Stryker production, there were numerous problems with EAC in the 46100 armor plate, notably the hatch covers and doors. The typical areas of crack nucleation were near the edges where cuts had been made. A previous U.S. Army Materials Technology Laboratory (MTL) investigation revealed that most of this damage from cracking could be avoided by changing the method for cutting the armor plate. MTL recommended a change from underwater plasma arc cutting to laser cutting techniques. By using laser cutting, the thicknesses of the remaining untempered martensite layer and the heat affected zone at the cut were significantly reduced (31). After implementing the MTL recommendations, the cracking problems were greatly reduced. In addition to these improvements, the enhanced precision inherent with the

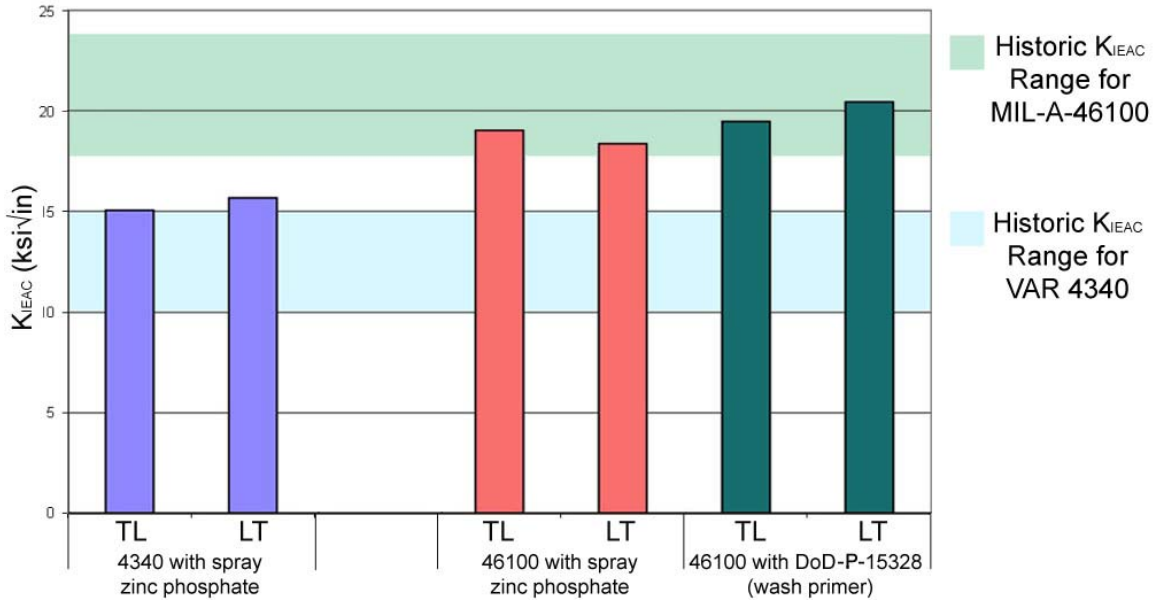

Figure 27. Average K_{IEAC} for pretreated 4340 and 46100 by orientation.

laser cutting improved the overall fit of individual armor plate components and significantly reduced the preloading induced at subsequent joining stages. Despite these significant production improvements, the risk for EAC remains a concern for Stryker fabrication, especially for any process or situation that when introduced could cause an influx of hydrogen.

Among the alternative pretreatments investigated, the hydrogen ions in the phosphoric acid component present in the Henkel spray zinc phosphate process remains the key area of concern. Before the procedures that investigated sensitivity to EAC on phosphated high hard are discussed, it should be noted that the DOD-P-15328D wash primer pretreatment coatings, used extensively on LAV's and on early production Stryker vehicles, also contained phosphoric acid. In addition, the CHEMINHIB 420 and KLEENINHIB 486 surface preparation stages currently used in conjunction with abrasive blast at the GDLS London facility and at the Militex subcontracted facility both are water soluble solutions for cleaning and inhibitor purposes. Any of these "wet" preparation stages listed represent varying degrees of vulnerability to hydrogen infiltration. The proposed zinc phosphating method, like the wash primer, is a spray process so the risks for hydrogen influx in spray application versus immersion methods for phosphating are likely to be inherently diminished. Another decrease in spray zinc phosphate risk comes from the recently revised Federal Specification TT-C-490D allowing the use of nonchromate final rinses; this eliminates hexavalent chromium based chromic acid, another potential source of hydrogen.

For the spray zinc phosphate sprayed rising step load EAC specimens there was no significant drop in K_{IEAC} vs. the DOD-P-15328D wash primer treated specimens for either the L-T or T-L orientations. All values were within the K_{IEAC} historic range for 46100 high hard steels. Spray

Table 10. Experimental conditions and K_{IEAC} values for rising step load specimens.

Sample ID	Sample Material	Sample Orientation	Hardness R_c	Surface Pretreatment	Crack Initiation Load P_u (lb)	K_{IEAC} (ksi \sqrt{in})	Pretreatment Applied Before/After Precracking
715064	4340	TL	50.8	Spray zinc phosphate	52.4	15.1	After
715057	4340	LT	50.9	Spray zinc phosphate	54.2	15.7	After
715038	46100	LT	50.7	Spray zinc phosphate	70	19.5	After
715037	46100	LT	50.4	Spray zinc phosphate	68	19.1	After
715042	46100	LT	51	Spray zinc phosphate	59	17.6	Before
715048	46100	TL	51.4	Spray zinc phosphate	79.5	22.5	After
715047	46100	TL	51.1	Spray zinc phosphate	62.9	18.0	After
715051	46100	TL	51.1	Spray zinc phosphate	58	16.6	Before
715043	46100	LT	51.4	DOD-P-15328D	71.4	20.4	After
715053	46100	TL	51.2	DOD-P-15328D	68.2	19.1	After
715054	46100	TL	51.2	DOD-P-15328D	68.9	19.9	After

Note: Rockwell C hardness values were averaged from three readings per specimen.

zinc phosphate that was applied to precracked samples even appeared to impart more EAC resistance than when the spray zinc phosphate was applied prior to precracking. As seen in table 10, regardless of orientation, the phosphate applied to precracked samples had on average, ~16% higher K_{IEAC} values. One possible explanation is that during the application process, phosphate may have penetrated into the precrack and thus provided the additional EAC resistance. Despite these interesting results, more tests with a larger statistical sampling would be necessary to validate this observation.

Results for coating adhesion for spray zinc phosphate as well as the abrasive blast and abrasive blast with CHEMINHIB 420 were significantly higher as well as more consistent than results for DOD-P-15328D. Coating adhesion performance should improve regardless of which of the wash primer alternatives is selected.

A key area of interest for surface pretreatments is the processing in the production environment. Currently abrasive blasting for the GDLS London plant is done off-facility at Militex, a local subcontractor responsible for cleaning and mechanical surface preparation and also a portion of the MIL-P-53022-10 primer coating application. The vehicles that are not primer coated at Militex receive an additional KLEENINHIB 486 water soluble cleaner/inhibitor process step in preparation for the interim transit period before the primer application at the GDLS facility. The processes as they stand currently are quite simple, figures 2–4 highlight differences between the

surface preparation and pretreatment stages conditional to the location of primer application as well as include the Henkel Bonderite spray zinc phosphate steps. In addition to introducing several more surface preparation stages, the pot temperatures on three of the Bonderite chemical spray steps must be heated to within a specified range. Additional care must be taken by the process personnel to control the Bonderite 952 stage with respect to “free acid” and “total acid” through a series of quality control inspections via titrations as specified in the Henkel Technical Process Bulletin. When the free acid levels were elevated, more orange-brown staining occurred on the zinc phosphated panels at the PARCOLENE 99 rinse stage. This staining was present in varying degrees for all of the spray zinc phosphated test panels that were prepared. Specifications TT-C-490 and MIL-DTL-16232G (32) for phosphating both mention the acceptability of these stains. Despite these stains, the zinc phosphate treated panels performed well in corrosion resistance and adhesion suggesting that zinc phosphating is somewhat forgiving from a process control standpoint and that the specification allowance for some staining appears to be reasonable. Through optimizations to free acid and total acid levels and periodic inspections to check the zinc phosphate coating weight vs. the specifications, the quality and appearance of the phosphate coating can be optimized as seen in figure 28.

If spray zinc phosphating is implemented in production as the pretreatment step before primer application, additional steps can be taken to reduce the risk for EAC. Phosphating specifications TT-C-490, MIL-DTL-16232G, and a previous phosphating study (33) all include instructions for hydrogen embrittlement heat treatment. Heat treatment schedules found in these publications consist of ageing at room temperature and should be executed before any loading of the material is permitted. The room temperature dwell times recommended differ between the specifications at 120 and 240 hr, respectively, for MIL-DTL-16232G and TT-C-490. Although the ageing period in MIL-C-16232G is shorter, this specification also includes a quality control test to determine the adequacy of the hydrogen embrittlement relief. The specification recommends periodic checks at intervals of 90–120 days in a production environment to ensure that the hydrogen embrittlement relief remains adequate.

Regardless of what pretreatment method is implemented, every attempt should be made throughout all stages of production to limit and relieve possible residual tensile stresses in the 46100 at locations such as welds or where cold working and/or machining has occurred. The manufacturing improvements made during previous LAV production cycles have done much to limit these residual stresses. Additional guidelines for residual stress relief as it applies to phosphating are also available in MIL-DTL-16232G.

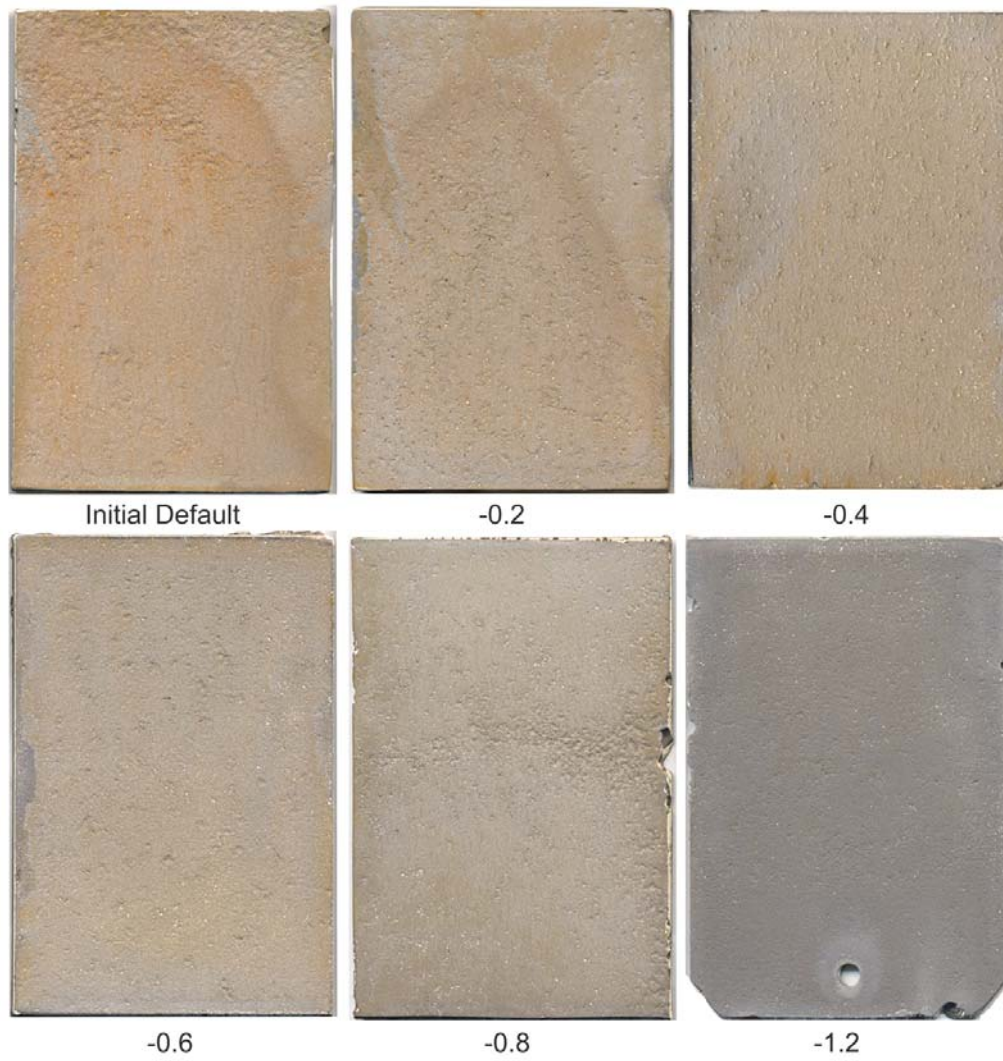

Figure 28. Changes in phosphate quality/appearance from adjustments to free acid concentration point values via increases of Henkel Primer 40 to the BONDERITE 952 spray zinc phosphate solution.

5. Conclusions

1. Spray zinc phosphate pretreatment improved the creepback resistance for CARC coated MIL-A-46100D high hard armor steel for both ASTM B 117-90 neutral salt fog and GM 9540P cyclic corrosion.
2. Coating adhesion for spray zinc phosphate pretreatment vs. abrasive blasting alone was marginally lower, but was still significantly improved when compared to DOD-P-15328D wash primer.
3. PPG CHEMINHIB 420 water soluble flash rust inhibiting coating did not degrade adhesion of the MIL-P-53022-10 (type II) primer to the substrate vs. substrates that were prepared with only abrasive blasting.
4. PPG CHEMINHIB 420 water soluble flash rust inhibiting coating greatly increased resistance to flash rusting when applied to abrasive blasted panels.
5. If spray zinc phosphating is not used as a pretreatment after abrasive blasting, the continued use of PPG CHEMINHIB 420 over abrasive blasted surfaces is recommended.
6. The results of the rising step load tests, indicate that spray zinc phosphate had no adverse effect on the K_{IEAC} for MIL-A-46100D high hard armor.
7. When spray zinc phosphate is used, quality control and inspection procedures in accordance with MIL-DTL-16232G for hydrogen embrittlement relief should be followed.

6. References

1. Gibb, H.; Lees, P.; Pinsky, P.; Rooney, B. Lung Cancer Among Workers in Chromium Chemical Production, *American Journal of Industrial Medicine* **2000**, 38, (2), 115–126, published online.
2. MIL-A-46100D (w/Amendment 1). *Armor Plate, Steel, Wrought, High-Hardness*. U.S. Department of Defense: Washington, DC, June **1990**.
3. DOD-P-15328D (Note 1). *Primer (Wash), Pretreatment (Formula No. 117 for Metals)*. U.S. Department of Defense: Washington, DC, March **1992**.
4. TT-C-490D Federal Specification. *Chemical Conversion Coatings and Pretreatments for Ferrous Surfaces (Base for Organic Coatings)*. General Services Administration: Washington, DC, July **2002**.
5. CHEMINHIB 420. *Water Soluble Short Term Corrosion Protective Coating—Product Data Sheet*. PPG Industries, Inc.: Euclid, OH, May **1996**.
6. Bruce, C. Hydrogen Damage. *Metals Handbook Ninth Edition*, 13, p 168.
7. MIL-P-53022-10. *Primer, Epoxy Coating, Corrosion Inhibiting, Lead and Chromate Free*. U.S. Department of Defense: Washington, DC, February **1992**.
8. MIL-C-53039A. *Coating, Aliphatic Polyurethane, Single Component, Chemical Agent Resistant*. U.S. Department of Defense: Washington, DC, May **1993**.
9. MIL-DTL-64159. *Coating, Water Dispersible Aliphatic Polyurethane, Chemical Agent Resistant*. U.S. Department of Defense: Washington, DC, January **2002**.
10. MIL-C-46168. *Coating, Aliphatic Polyurethane, Chemical Agent Resistant*. Revision D, Amendment 3; U.S. Department of Defense: Washington, DC, May **1993**.
11. SSPC-SP 10. *Near White Blast Cleaning*. Steel Structures Painting Council: Pittsburgh, PA, November **1982**.
12. KLEENINHIB 486 (CHEMKLEEN® 340 – U.S. Trade Name). *Cleaning Solution - Product Data Sheet*; PPG Industries, Inc.: Euclid, OH, May 1996.
13. RECOOL ADDITIVE 15. *Concentrated Rust Inhibiting Solution Coating - Product Data Sheet*. PPG Industries, Inc.: Euclid, OH, March 2003.
14. PARCO CLEANER 319. *Alkaline Cleaner - Technical Process Bulletin No. 0993*. Henkel Surface Technologies: Madison Heights, MI, April 1990.

15. FIXODEEN ZL. *Conditioning Pretreatment - Technical Process Bulletin No. 1569*. Henkel Surface Technologies: Madison Heights, MI, November 1993.
16. BONDERITE 952. *Polycrystalline Conversion Coating Process - Technical Process Bulletin No. 1046*. Henkel Surface Technologies: Madison Heights, MI, April 1997.
17. PARCOLENE 99A. *Chromium Free Post Treatment - Technical Process Bulletin No. 1695*. Henkel Surface Technologies: Madison Heights, MI, July 1997.
18. ASTM B 117-90. *Standard Method of Salt Spray (Fog) Testing*. American Society for Testing and Materials: West Conshohocken, PA, **1990**.
19. GM 9540P. *Accelerated Corrosion Test; GM 9540P*. General Motors Engineering Standards, **1997**.
20. ASTM D 1654-79A. *Standard Method for Evaluation of Painted or Coated Specimens Subjected to Corrosive Environments*. American Society for Testing and Materials: West Conshohocken, PA, **1984**.
21. ASTM D 3359. *Standard Test Methods for Measuring Adhesion by Tape Test*. American Society for Testing and Materials: West Conshohocken, PA, **1987**.
22. ASTM D 4541. *Standard Test Method for Pull-Off Strength of Coated Specimens Subjected to Corrosive Environments*. American Society for Testing and Materials: West Conshohocken, PA, **1989**.
23. ASTM D 1735. *Standard Practice for Testing Water Resistance of Coatings Using Water Fog Apparatus*. American Society for Testing and Materials: Philadelphia, PA, **1987**.
24. ASTM E 399-97. *Standard Test Method for Plane Strain Fracture Toughness of Metallic Materials*. American Society for Testing and Materials: West Conshohocken, PA, **1998**.
25. Pasternak, R.; Pepi, M.; Pelletier, G.; Amos, C.; Valavanis, M. *Test Specimens for Mechanical Property Determination*. MTL-SP-87-5; U.S. Army Materials Technology Laboratory Special Publication: Watertown, MA, 1987.
26. ASTM F 1624-95. *Standard Test Method for Measurement of Hydrogen Embrittlement in Steel by the Incremental Loading Technique*. American Society for Testing and Materials: West Conshohocken, PA, **1995**.
27. Tyler, P. S.; Levy, M.; Raymond, L. Investigation of the Conditions for Crack Propagation and Arrest Under Cathodic Polarization by Rising Step Load Bend Testing. *Proceedings from the 1992 Tri-Service Conference on Corrosion*, Plymouth, MA, May 1992.
28. Grendahl, S.; Kilbane, R. Environmentally Assisted Cracking Concerns for Cadmium Replacement. *Proceedings from the 2002 Tri-Service Corrosion Conference*, San Antonio, TX, January 2002.

29. Herman, W. A.; Campbell, G. M. *Environmental Assisted Cracking in High Hardness Armor Steel*. TR-85-28; U.S. Army Materials and Mechanics Research Center: Watertown, MA, 1985.
30. Dawson, D. *Development of a Stress Corrosion Cracking Test for Armor Alloys*. TN 72-5; U.S. Army Materials and Mechanics Research Center: Watertown, MA, 1972.
31. Wells, M. G.; Weiss, R.; Montgomery, J.; Melvin, T. *LAV Armor Plate Study*. MTL-TR-92-26; U.S. Army Materials Technology Laboratory: Watertown, MA, April 1992.
32. MIL-DTL-16232G. *Phosphate Coating, Heavy, Manganese or Zinc Base*. U.S. Department of Defense: Washington DC, November 1978.
33. Austin, P.; Chek, S.; Lurie, W. *Investigation of the Effect of Hydrogen Embrittlement and its Relief in Phosphate Coated AISI 4340 and 1095 Steels*. NAVORD Report 6509, NWPW-T-20-59; U.S. Naval Weapons Plant: Washington, DC, August 1959.

NO. OF COPIES ORGANIZATION

- 1 DEFENSE TECHNICAL
(PDF INFORMATION CTR
ONLY) DTIC OCA
8725 JOHN J KINGMAN RD
STE 0944
FORT BELVOIR VA 22060-6218
- 1 US ARMY RSRCH DEV &
ENGRG CMD
SYSTEMS OF SYSTEMS
INTEGRATION
AMSRD SS T
6000 6TH ST STE 100
FORT BELVOIR VA 22060-5608
- 1 INST FOR ADVNCD TCHNLGY
THE UNIV OF TEXAS
AT AUSTIN
3925 W BRAKER LN STE 400
AUSTIN TX 78759-5316
- 1 US MILITARY ACADEMY
MATH SCI CTR EXCELLENCE
MADN MATH
THAYER HALL
WEST POINT NY 10996-1786
- 1 DIRECTOR
US ARMY RESEARCH LAB
IMNE AD IM DR
2800 POWDER MILL RD
ADELPHI MD 20783-1197
- 3 DIRECTOR
US ARMY RESEARCH LAB
AMSRD ARL CI OK TL
2800 POWDER MILL RD
ADELPHI MD 20783-1197
- 3 DIRECTOR
US ARMY RESEARCH LAB
AMSRD ARL CS IS T
2800 POWDER MILL RD
ADELPHI MD 20783-1197

NO. OF COPIES ORGANIZATION

- ABERDEEN PROVING GROUND
- 1 DIR USARL
AMSRD ARL CI OK TP (BLDG 4600)

<u>NO. OF</u> <u>COPIES</u>	<u>ORGANIZATION</u>	<u>NO. OF</u> <u>COPIES</u>	<u>ORGANIZATION</u>
10	PROJECT MANAGER STRYKER BRIG COMBAT TEAM US ARMY TACOM SFAE GCS BCT E T DEAN 6501 E ELEVEN MILE RD WARREN MI 48397-5000	3	MAINTENANCE DIRECTORATE M SHARPE 814 RADFORD BLVD STE 20329 ALBANY GA 31704-0329
5	PROJECT MGR COMBAT SYSTEMS SFAE GCS CS S KEVIN HOUSER 6501 E ELEVEN MILE RD WARREN MI 48397-5000	1	NAVAIR S SPADAFORA CODE 4341 48066 SHAW RD BLDG 2188 PATUXENT RIVER MD 20670-5304
5	PROJECT MGR UNIT OF ACTION SFAE GCS UA E E MILLER 6501 E ELEVEN MILE RD WARREN MI 48397-5000	1	NAVAIR C MATZDORF CODE 4341 48066 SHAW RD BLDG 2188 PATUXENT RIVER MD 20670-5304
3	US ARMY TACOM I HANDSY 6501 E ELEVEN MILE RD WARREN MI 48397-5000	1	NAVAIR CODE 4341 B NICKERSON 48066 SHAW RD BLDG 2188 PATUXENT RIVER MD 20670-5304
1	COMMANDER NSWC CARDEROCK DIV CODE 613 A SHEETZ 9500 MACARTHUR BLVD WEST BETHESDA MD 20817-5700	5	GEN DYNAMICS LAND SYS K WELCH MZ 436 21 40 38500 MOUND RD STERLING HEIGHTS MI 48310-3200
1	COMMANDER NSWC CARDEROCK DIV R HAYS CODE 613 9500 MACARTHUR BLVD WEST BETHESDA MD 20817-5700	2	GEN DYNAMICS LAND SYS E MATTHEWS MZ 436 21 40 38500 MOUND RD STERLING HEIGHTS MI 48310-3200
2	MAINTENANCE CTR ENGR DEPT S ALLEN CODE 882 814 RADFORD BLVD STE 20325 ALBANY GA 31704-0325	1	RED RIVER ARMY DEPOT AMSTA RR MC M STARKS 100 MAIN DR TEXARKANA TX 75507-5000
1	MAINTENANCE CTR B BAKER CODE 882 814 RADFORD BLVD STE 20325 ALBANY GA 31704-0325	1	ANNISTON ARMY DEPOT ASTMA AN GMPO T POLLARD 7 FRANKFORD AVE ANNISTON AL 36201-4199

NO. OF
COPIES ORGANIZATION

- 2 COMMANDER
 NAVAL SEA SYS COMMAND
 SEA 05M1
 2531 JEFFERSON DAVIS HWY
 ARLINGTON VA 22242-5171

- 2 OFFICE OF NAVAL RESEARCH
 BALLSTON TOWERS
 A PEREZ CODE 332
 800 N QUINCY ST
 ARLINGTON VA 22217-5167

- 1 NAVAL RESEARCH LAB
 ENVIRON PROTECTION BRANCH
 CODE 6310
 4555 OVERLOOK AVE SW
 WASHINGTON DC 20375-5320

- 2 MARINE CORPS SYS COMMAND
 J REDFERN
 R STITH
 2033 BARNETT AVE
 SUITE 315
 QUANTICO VA 22134-5010

- 2 DRPM EFV
 WORTH AVE TECH ANNEX
 R CROSS
 S BETTADAPUR
 14041 WORTH AVE
 WOODBIDGE VA 22192-4123

ABERDEEN PROVING GROUND

- 26 DIR USARL
 AMSRD ARL WM M
 J BEATTY (2 CPS)
 AMSRD ARL WM MC
 J ESCARSEGA (2 CPS)
 J KELLEY (5 CPS)
 C MILLER (5 CPS)
 B PLACZANKIS (10 CPS)
 AMSRD ARL WM MD
 J MONTGOMERY (2 CPS)

NO. OF
COPIES ORGANIZATION

5 ENGRNG DESIGN & DEV
GEN DYNAMICS LAND
SYS-CANADA
K CLAVET
PO BOX 7003
LONDON ON CANADA N5Y 6L8

10 ENGRNG DESIGN & DEV
GEN DYNAMICS LAND
SYS-CANADA
C UFFEN
PO BOX 7003
LONDON ON CANADA N5Y 6L8