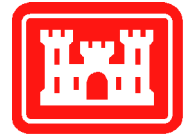


**Cold Regions Research  
and Engineering Laboratory**

**ERDC/CRREL TR-05-1**



**US Army Corps  
of Engineers®**  
Engineer Research and  
Development Center

# **Improved Performance of Unpaved Roads During Spring Thaw**

Karen S. Henry, James P. Olson, Stephen P. Farrington,  
and John Lens

February 2005

# Improved Performance of Unpaved Roads During Spring Thaw

Karen S. Henry\*, James P. Olson†, Stephen P. Farrington\*\*,  
and John Lens††

*\*Engineer Research and Development Center  
Cold Regions Research and Engineering Laboratory  
Hanover, New Hampshire 03755*

*†University of Vermont  
Burlington, Vermont*

*\*\*Applied Research Associates, Inc.*

*††GeoDesign, Inc.*

Approved for public release; distribution is unlimited.

Prepared for VERMONT AGENCY OF TRANSPORTATION AND  
FEDERAL HIGHWAY ADMINISTRATION

## ABSTRACT

Unpaved roads in Vermont are subject to deterioration from seasonal freezing and thawing, and many towns have roads that suffer chronic serviceability problems during the so-called “spring thaw,” or mud season. Several techniques thought to mitigate deterioration of unpaved roads during spring thaw were constructed on test sections of unpaved roads in two towns. Each potential remedy was aimed at providing some combination of limiting the availability of moisture in the winter, improving drainage during spring, and strengthening the upper portion of the road. Each technique used local and/or commercially available materials, and all were easy to construct, i.e., a town road crew could build them. For two spring thaw seasons, we compared strength estimates based on dynamic cone penetrometer tests and the percentage of the road surface rutted for treated and control sections. Methods that permanently improved the strength of the top 12 inches of the road or decreased the water content of the upper 12 inches of the road resulted in significant performance improvement during spring thaw. Cement and cellular confinement systems worked well by improving the strength of the upper layers of the soil. Two new techniques—geowrap, comprising clean sand sandwiched by geotextile separators placed 12–18 inches deep, and the patented Geosynthetic Capillary Barrier Drain—provided benefit by keeping the upper layers of the soil relatively dry. Geogrid and geotextile separators placed 12 inch deep and trench drains parallel to the road provided no observable benefit.

DISCLAIMER: The contents of this report are not to be used for advertising, publication, or promotional purposes. Citation of trade names does not constitute an official endorsement or approval of the use of such commercial products. All product names and trademarks cited are the property of their respective owners. The findings of this report are not to be construed as an official Department of the Army position unless so designated by other authorized documents.  
DESTROY THIS REPORT WHEN IT IS NO LONGER NEEDED. DO NOT RETURN TO THE ORIGINATOR.

## CONTENTS

CONVERSION FACTORS.....	vii
PREFACE.....	viii
1 INTRODUCTION.....	1
1.1 Background.....	1
1.2 Problem Statement.....	2
1.3 Report organization.....	3
2 TECHNICAL APPROACH.....	4
2.1 Experimental Design.....	4
2.2 Candidate Remedies.....	5
3 SITE SELECTION.....	10
4 CONSTRUCTION.....	11
4.1 Windsor.....	11
4.2 Westford.....	18
5 CHARACTERIZATION AND MONITORING.....	23
5.1 Laboratory Evaluation.....	23
5.2 Dynamic Cone Penetrometer Testing.....	23
5.3 Soil Moisture Resistivity and Temperature (SMRT) Probe Profiling.....	24
5.4 Sensors.....	25
6 RESULTS.....	28
6.1 Freezing seasons for 2001-02 and 2002-03.....	28
6.2 Overview of thaw monitoring program.....	30
6.3 Incomplete data recovery.....	31
6.4 Windsor.....	31
6.5 Westford.....	48
7 DISCUSSION.....	62
8 COSTS.....	64
8.1 Construction.....	64
8.2 Maintenance.....	65
9 SUMMARY AND CONCLUSIONS.....	66
9.1 Performance of mud season remedies.....	66

9.2 Other observations and recommendations related to spring thaw road maintenance .....	67
9.3 Recommendation for future research.....	67
REFERENCES .....	69
APPENDIX A: SOIL TEMPERATURES IN WINDSOR AND WESTFORD, VERMONT, 2002 AND 2003 .....	70
APPENDIX B: PHOTOGRAPHS OF TEST SECTIONS TAKEN DURING MUD SEASON IN 2002 AND 2003.....	86
APPENDIX C: DYNAMIC CONE PENETROMETER MEASUREMENTS IN 2002 AND 2003, WINDSOR .....	160
APPENDIX D: SMRT PROBE DATA 2003, WESTFORD.....	161

## ILLUSTRATIONS

Figure 1. Typical site layout .....	5
Figure 2. Geogrid .....	7
Figure 3. Cellular confinement system (Geocells) .....	8
Figure 4. Improved drainage .....	8
Figure 5. Geosynthetic Capillary Barrier Drain .....	8
Figure 6. Geowrap .....	9
Figure 7. Cement stabilization .....	9
Figure 8. Installation of geotextile separator in Windsor, Area 1 .....	13
Figure 9. Geotextile separator in Windsor, Area 1, during construction .....	13
Figure 10. Installation of geogrid in Windsor, Area 2 .....	14
Figure 11. Installation of drainage in Windsor, Area 2 .....	14
Figure 12. Top geotextile layer of geowrap during construction in Windsor, Area 3. ....	14
Figure 13. Geotextile separator during construction in Windsor, Area 4 .....	15
Figure 14. GCBD during construction in Windsor, Area 4 .....	16
Figure 15. Air photo of Hunt Road, Windsor, showing Areas 1, 2, and 3 .....	17
Figure 16. Air photo of Hunt Road, Windsor, showing Area 4 .....	17
Figure 17. Geocell test section during construction .....	19
Figure 18. Westford Drain test section during construction .....	20
Figure 19. Westford Geogrid test section during construction, showing original road surface material being placed on the grid .....	21
Figure 20. Westford Cement test section during construction, showing original road surface material being mixed with cement to a depth of 8 in. ....	22
Figure 21. Air photo of Old Stage Road in Westford .....	22

Figure 22. Dynamic cone penetrometer for determining soil strength as a function of depth .....	24
Figure 23. Sample soil moisture, temperature, and resistivity profile obtained using a SMRT probe .....	25
Figure 24. Schematic of in situ thermocouples .....	26
Figure 25. Schematic of test site instrumentation .....	26
Figure 26. Example plot of temperature monitoring data .....	27
Figure 27. Cumulative degree-days for Newport, NH, for 2001-02 and 2002-03 freezing seasons .....	29
Figure 28. Cumulative degree-days for Essex Junction, VT, for 2001-02 and 2002-03 freezing seasons .....	29
Figure 29. Control East of Area 4 on April 2, 2002, showing the differences in moisture content of the road surface due to degree of sun exposure.....	32
Figure 30. Area 4, looking west, after about 6 in. of “gravel” was added on April 2, 2002 .....	33
Figure 31. Air temperatures at Newport and datalogger enclosure temperature, temperature measurements in the soil at 6 in. depth, annotated timeline, weighted CBR determinations for the top 3 in. of the road surface, and percentage of the test section rutted for Area 1, 2002 mud season .....	34
Figure 32. Air temperatures at Newport and datalogger enclosure temperature, temperature measurements in the soil at 6 in. depth, annotated timeline, weighted CBR determinations for the top 3 in. of the road surface, and percentage of the test section rutted for Area 1, 2003 mud season .....	35
Figure 33. Air temperatures at Newport and datalogger enclosure temperature, temperature measurements in the soil at 10 or 12 in. depth (for Grid section), annotated timeline, weighted CBR determinations for the top 3 in. of the road surface, and percentage of the test section rutted for Area 2, 2002 mud season .....	36
Figure 34. Air temperatures at Newport and datalogger enclosure temperature, temperature measurements in the soil at 10 or 12 in. depth (for Grid section), annotated timeline, weighted CBR determinations for the top 3 in. of the road surface, and percentage of the test section rutted for Area 2, 2003 mud season .....	37
Figure 35. Corrugations and potholes on the Grid section, Area 2, March 4, 2002 .....	39
Figure 36. Temperature profiles on March 12, 2002, in test sections located in Areas 2 and 3 in Windsor, Vermont .....	40
Figure 37. Air temperatures at Newport and datalogger enclosure temperature, annotated timeline, weighted CBR determinations for the top 3 in. of the road surface, percentage of the test section rutted, and number of potholes in the test sections for Area 3, 2002 mud season .....	41

Figure 38. Air temperatures at Newport, annotated timeline, weighted CBR determinations for the top 3 in. of the road surface, percentage of the test section rutted, and number of potholes in the test sections for Area 3, 2003 mud season .....	42
Figure 39. CW and Geowrap sections on March 11, 2002 .....	43
Figure 40. Cement section on March 17, 2003, showing drying compared to the CE .....	43
Figure 41. CW of Area 4 on March 24, 2003, showing its sunny exposure .....	44
Figure 42. Air temperatures at Newport and datalogger enclosure temperature, temperature measurements in the soil at 6 in. depth, annotated timeline, weighted CBR determinations for the top 3 in. of the road surface, and percentage of the test section rutted for Area 4, 2002 mud season .....	46
Figure 43. Air temperatures at Newport and datalogger enclosure temperature, temperature measurements in the soil at 6 in. depth, annotated timeline, weighted CBR determinations for the top 3 in. of the road surface, and percentage of the test section rutted for Area 4, 2003 mud season .....	47
Figure 44. Air temperatures at Essex Junction, temperature measurements in the soil at 6 in. depth, and weighted CBR determination for the top 3 in. of the road surface for the Geocell 1 test section, 2002 mud season ....	49
Figure 45. Air temperatures at Essex Junction, temperature measurements in the soil at 6 in. depth, and weighted CBR determination for the top 3 in. of the road surface for the Geocell 2 test section, 2002 mud season ....	50
Figure 46. Air temperatures at Essex Junction, temperature measurements in the soil at 6 in. depth, and weighted CBR determination for the top 3 in. of the road surface for the Geocell 1 test section, 2003 mud season ....	51
Figure 47. Air temperatures at Essex Junction, temperature measurements in the soil at 6 in. depth, and weighted CBR determination for the top 3 in. of the road surface for the Geocell 2 test section, 2003 mud season ....	52
Figure 48. Air temperatures at Essex Junction, temperature measurements in the soil at 6 in. depth, and weighted CBR determination for the top 3 in. of the road surface for the Drain test section, 2002 mud season .....	54
Figure 49. Air temperatures at Essex Junction, temperature measurements in the soil at 6 in. depth, and weighted CBR determination for the top 3 in. of the road surface for the Drain test section, 2003 mud season .....	55
Figure 50. Air temperatures at Essex Junction, temperature measurements in the soil at 6 in. depth, and weighted CBR determination for the top 3 in. of the road surface for the Grid test section, 2002 mud season .....	57
Figure 51. Air temperatures at Essex Junction, temperature measurements in the soil at 6 in. depth, and weighted CBR determination for the top 3 in. of the road surface for the Grid test section, 2003 mud season .....	58

Figure 52. Air temperatures at Essex Junction, temperature measurements in the soil at 6 in. depth, and weighted CBR determination for the top 3 in. of the road surface for the Cement test section, 2002 mud season .....	60
Figure 53. Air temperatures at Essex Junction, temperature measurements in the soil at 6 in. depth, and weighted CBR determination for the top 3 in. of the road surface for the Cement test section, 2003 mud season .....	61

## TABLES

Table 1. Summary of remedies evaluated .....	6
Table 2. Summary of geotextiles used .....	6
Table 3. Summary of geogrids used .....	7
Table 4. Drainage products used .....	7
Table 5. Areas, test, and control sections in Windsor .....	12
Table 6. Test and control sections in Westford .....	18
Table 7. Soil classification information for Hunt Road and Old Stage Road .....	23
Table 8. Freezing season data, based on National Weather Service data, Newport, NH, and Essex Junction, VT .....	28
Table 9. Estimated costs for various section types .....	64
Table 10. Mud season remedies and summary of results .....	66

## CONVERSION FACTORS, NON-SI TO SI UNITS OF MEASUREMENT

Non-SI units of measurement used in this report can be converted to SI units as follows:

Multiply	By	To obtain
feet	0.3048	meters
inches	0.0254	meters

## PREFACE

This report was prepared by Dr. Karen S. Henry, Research Civil Engineer, Civil and Infrastructure Engineering Branch, Cold Regions Research and Engineering Laboratory (CRREL), U.S. Army Engineer Research and Development Center (ERDC); James P. Olson, Associate Professor Emeritus, University of Vermont; Stephen P. Farrington, Senior Engineer, Applied Research Associates, Inc.; and John Lens, Principal, GeoDesign, Inc. Ms. Rosa Affleck, Civil Engineer, CRREL; Mr. Aaron Humphrey, Civil Engineer, GeoDesign, and Mr. Rob Achilles, Civil Engineer, GeoDesign, all significantly contributed to data gathering. Our thanks to Shawn Ricker of Applied Research Associates, who helped develop the automatically recording DCP and trained us to use it.

Funding for this project was provided by the Vermont Agency of Transportation in cooperation with the Federal Highway Administration.

The contents of this report are not to be used for advertising or promotional purposes. Citation of brand names does not constitute an official endorsement or approval of the use of such commercial products.

This report was prepared under the general supervision of Steven Flanders, Chief, Civil and Infrastructure Engineering Branch; Dr. Lance Hansen, Deputy Director; and James L. Wuebben, Acting Director, CRREL.

The Commander and Executive Director of the Engineering Research and Development Center is COL James R. Rowan. The Director is Dr. James R. Houston.

# **IMPROVED PERFORMANCE OF UNPAVED ROADS DURING SPRING THAW**

KAREN S. HENRY, JAMES P. OLSON,  
STEPHEN P. FARRINGTON, AND JOHN LENS

## **1 INTRODUCTION**

A Vermont Agency of Transportation project was undertaken by the University of Vermont, U.S. Army Engineer Research and Development Center's Cold Regions Research and Engineering Laboratory (ERDC CRREL), GeoDesign, Inc., and Applied Research Associates, Inc., (ARA) to evaluate the performance and cost effectiveness of a variety of potential remedies against deterioration of unpaved roads during spring thaw. Candidate remedies were installed in test sections in 2001. Test sections alternated with unimproved control sections along town-maintained roads in Westford and Windsor, Vermont. Two seasons (winter freeze through spring thaw) of monitoring followed construction, and the study culminated in analysis of the data obtained.

### **1.1 Background**

Unpaved (gravel) roads in Vermont are subjected to deterioration from seasonal freezing and thawing. Out of a total of 12,812 miles of Vermont roads, 8,462 miles (66%) are Class 3 town highways, which have a minimum standard to be negotiable by a passenger car under normal conditions all seasons of the year. Each town has a small portion of these roads that suffer chronic serviceability problems during the so-called "spring thaw," also known as mud season, and each year, local road commissioners are forced to mitigate deterioration on problem stretches of unpaved roads within their towns.

Vermont towns recognize the need for dealing with the loss of road serviceability during mud season. The near-term solution to the problem is to wait until thaw is complete and the roadbed stabilizes. However, sometimes the roads may be either unsafe or impassable and thus potentially pose a severe risk to users.

For example, it may be impossible for emergency vehicles to travel on a distressed road. The most visible signs of deterioration during mud season are deep rutting of the surface, high moisture content of the road base and surface, and continuing plastic deformations under even the lightest of traffic. Road crews often repair the affected sections by re-grading and adding more “gravel” to the surface. Over time, some towns have been successful in reducing the number of trouble spots by incrementally improving the structural section of the roadbed, while other road sections, even after many years of maintenance, still experience serious degradation.

Although it is common knowledge that construction with clean, non-frost-susceptible material will help prevent thaw weakening, many Vermont towns are constrained by available funding to acquire less-than-ideal materials. Past solutions in many towns have required extensive processing of material from local deposits or hauling more appropriate material in over long distances. The capital costs of these activities are often unpalatable to town officials and citizens, so town road crews use what is available in local “gravel pits” with minimal or no processing beyond extraction. Town road commissioners can seldom obtain budget approval to include engineered materials, such as geosynthetics and soil additives, in their improvement plans. (Interviewed road commissioners have indicated that capital cost is their primary constraint.) Therefore, this project attempted to ensure that candidate remedies tested were cost efficient and that cost information is provided.

## **1.2 Problem Statement**

Unpaved roads are composed of a combination of fine-grained particles and coarse aggregates (gravel). Keeping moisture levels in balance is critical to maintaining the strength of these granular mixtures and thus road stability. Too little water causes excessive dust, while too much creates mud. Excessive water during mud season causes weakening, the water being generated by the thawing of soil that frost heaved.

A combination of three factors results in frost heave of soil: freezing temperatures, water, and frost-susceptible soil. Silts, silty sands, and nonplastic clays are the most frost-susceptible soils. Unpaved roads in Vermont often contain significant amounts of fines and are frost susceptible. During frost heaving, soil water flows to the freezing front under a suction gradient. Ice lenses grow somewhat above the freezing front when the pore pressure exerted by crystal growth exceeds overburden pressure. This process significantly increases the overall water content of the soil and usually displaces the surface, causing frost heave. With the onset of above-freezing temperatures and subsequent thawing of the

roadway, excess moisture from the thawed lenses is trapped above deeper frozen layers, causing the soil to soften, lose strength, and suffer severe deformation under traffic loads.

### **1.3 Report organization**

This report is organized as follows: In Section 2, we describe the goals of the project and the technical approach used to gather performance information for a variety of potential means of mitigating mud season problems. This includes detailed test section design information. Sections 3 and 4 contain site selection and construction information. Soil characteristics and the monitoring program are described in Section 5. Performance information—the results of the study—are presented in Section 6. We discuss the results in Section 7, and present cost information in Section 8. Section 9 contains conclusions and recommendations.

## 2 TECHNICAL APPROACH

In pursuit of three goals—demonstrating the effectiveness of candidate technical remedies, documenting the costs of successful remedies, and transferring findings and decision support tools to town road officials—the project team performed the following tasks:

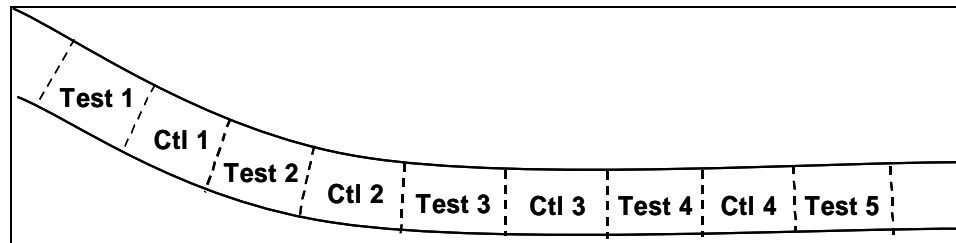
- Consulted with local road commissioners to solicit interest in project participation and to identify candidate sites for test sections in their respective towns;
- Developed a protocol for field measurements and instrumentation to be incorporated in test and control sections;
- Developed prototype designs for remedies to be constructed in test sections;
- Coordinated with local road crews and a private contractor to construct the test sections and install instrumentation;
- Collected performance data during two thaw seasons; and
- Assessed performance improvements in the test sections as compared to adjacent control sections.

### 2.1 Experimental Design

Towns will adopt improved practices only if there are proven cost advantages. The experimental design aimed to provide a rational, quantitative basis for comparing various remedies for mud season degradation of roads.

Using several test sections, we evaluated and demonstrated the effectiveness of various remedies in Westford and Windsor, Vermont. Since mud season severity varies from year to year, the study plan called for untreated control sections to be interspersed with, and adjoining, the test sections. The inclusion of these control sections facilitated direct comparison between improved and unimproved road performance for each mud season at each site. A typical site layout is depicted in Figure 1. Test sections typically spanned a 100-ft length.

With the guidance of the project team, towns installed test sections on roads that experience severe thaw weakening, manifested as deep ruts that disrupt traffic. The control sections were left untreated. The project team then observed and documented conditions of both the control and the test sections through two thaw seasons (2002 and 2003).



**Figure 1. Typical site layout, showing test sections interspersed with control sections. Sections were typically 100 ft long.**

Rapid deterioration of strength and spatial variability of strength even within a section make it difficult to obtain meaningful strength measurements in the road section. A dynamic cone penetrometer (DCP) was used to evaluate soil strength during thaw. In addition, a visual record was made of the construction installation and post-installation performance via still photographs and videotape. Test and control sections were instrumented with thermocouples at multiple depths in the roadway and were monitored during the springs of 2002 and 2003.

## 2.2 Candidate Remedies

Each treatment we evaluated was aimed at providing some combination of these goals: limiting the availability of moisture in the winter, improving drainage during spring, and strengthening the upper portion of the road. All remedies we evaluated implemented the following strategies alone or in combination:

- Improved lateral and/or vertical drainage;
- Reduced capillary rise of water into surface layers of the road, using a capillary barrier;
- Separation (using a geotextile) of underlying frost-susceptible soils from the capillary barrier or draining layer; or
- Mechanical stabilization to strengthen the road surface layers.

For example, gravel-filled cells confine lateral soil movement in addition to forming a well-draining layer. Table 1 contains a short description of each remedy and the town in which it was used. Tables 2–4 give technical information about the geosynthetics installed in the project, and Figures 2–7 show candidate remedy designs. The Geosynthetic Capillary Barrier Drain is an invention (Henry and Stormont 2000) and has been shown in the laboratory to increase the rate of water removal from pavement base courses after water is applied to the surface (Henry et al. 2002).

**Table 1. Summary of remedies evaluated.**

Remedy	Site	Description
Geogrid	Westford and Windsor	Tensar® geogrid placed 12 in. below the road surface as a reinforcing layer
Separator	Windsor	Geotextile separator placed 12 in. below the road surface
Geocell	Westford	Cellular confinement system placed 12–14 in. below the road surface and sandwiched between geotextile separators. One section used 6-in.-thick cells, and the other used 4-in.-thick cells.
Drainage	Westford and Windsor	Improved drainage at the edge of the roadway, using a trench drain a few feet lower than the road surface and parallel to the edge, constructed of crushed stone around a 4-in.-diameter perforated PVC drain, all wrapped in geotextile.
GCBD	Windsor	Patented Geosynthetic Capillary Barrier Drain placed 12 in. below the road surface.
"Geowrap"	Windsor	An encapsulated, free-draining, gravel layer, wrapped in geotextile to provide strength and maintain materials separation installed from 12 to 18 in. below the road surface.
Cement Stabilization	Westford and Windsor	Portland cement to 6% by weight added to the native road surface material to create a stabilized surface course. In Windsor the cement was added to a 12-in. thickness. In Westford, the cement was added to an 8-in. thickness at a slightly higher percentage—about 8% by weight.

**Table 2. Summary of geotextiles used.**

Geotextile	Construction	Mass per unit area (g m <sup>-2</sup> )	AOS (mm)	Trapezoidal tear strength (kN)	Wide-width tensile strength at 5% strain (kN m <sup>-1</sup> ) MD/XD	Ultimate tensile strength (kN m <sup>-1</sup> ) – % MD/XD
Amoco 4553* (7 rolls)	NW-PP	240	0.15	0.335	N.A.	N.A.
Thermalglass <sup>†</sup>	W-fiberglass	2370	0.075	N.A.	N.A.	N.A.
Geotextile heat bonded to Tendrain	NW-PP	203	0.21	0.29	N.A.	N.A.

MD: machine direction. XD: Cross-machine direction. N.A.: not available. NW: nonwoven.

PP: polypropylene. AOS: apparent opening size (ASTM D 4751).

Trapezoidal tear strength determined according to ASTM D4533. Wide-width tensile strength at 5% strain and ultimate tensile strength determined according to ASTM D4595.

\*Used as separator.

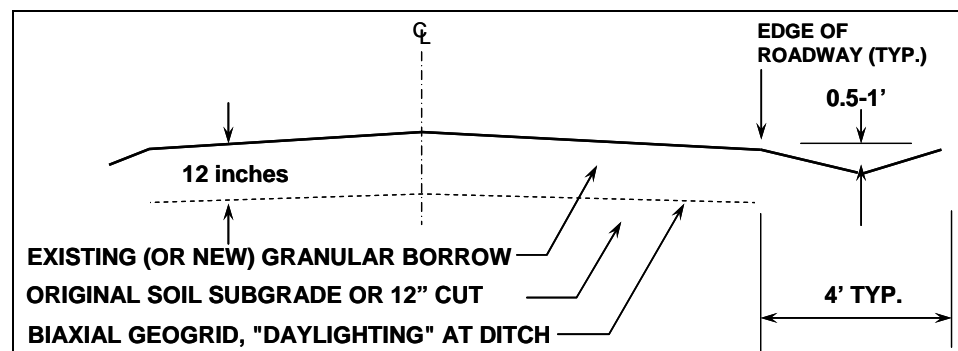
<sup>†</sup>Manufactured by Amatex Corporation, Norristown, PA.

**Table 3. Summary of geogrids used.**

Geogrid	Construction, polymer	Aperture size, mm ( in.)		Wide-width tensile strength at 5% strain, $\text{kN m}^{-1}$ (lb ft $^{-1}$ )	
		MD	XD	MD	XD
Tensar BX11 0060 (4 x 50 m roll)	Integrally formed, PP	25.4 (1.0)	33.0 (1.3)	8.5 (580)	13.4 (920)
Tensar BX12 0060 (4 x 50 m roll)	Integrally formed, PP	25.4 (1.0)	33.0 (1.3)	11.8 (810)	19.8 (1360)

**Table 4. Drainage products used.**

Drainage product	Construction
AASHTO M 252 Type C pipe	Corrugated pipe, 100 mm (4 in.) diameter, with sock
Tendrain (manufactured by Tenax)	Planar structure of thick supporting ribs with diagonally placed top and bottom ribs and a thermally bonded, non-woven geotextile on one side
Geosynthetic Capillary Barrier Drain (G CBD)	Tenax tri-planar geonet overlain by thermalglass (see description in geotextile table)

**Figure 2. Geogrid.**

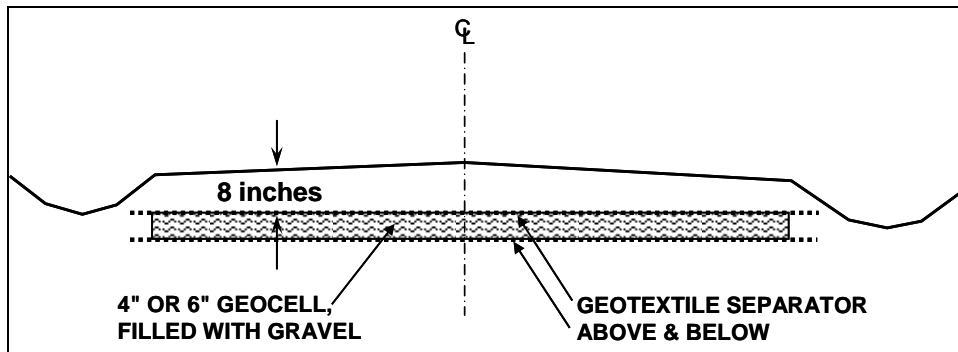


Figure 3. Cellular confinement system (Geocells).

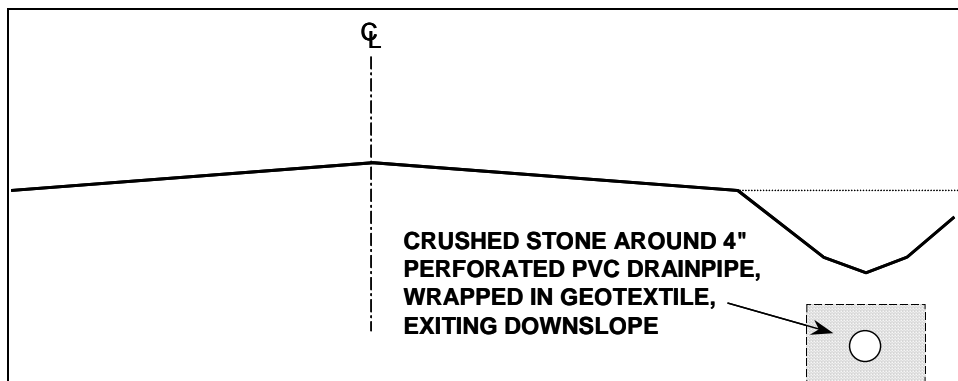


Figure 4. Improved drainage.

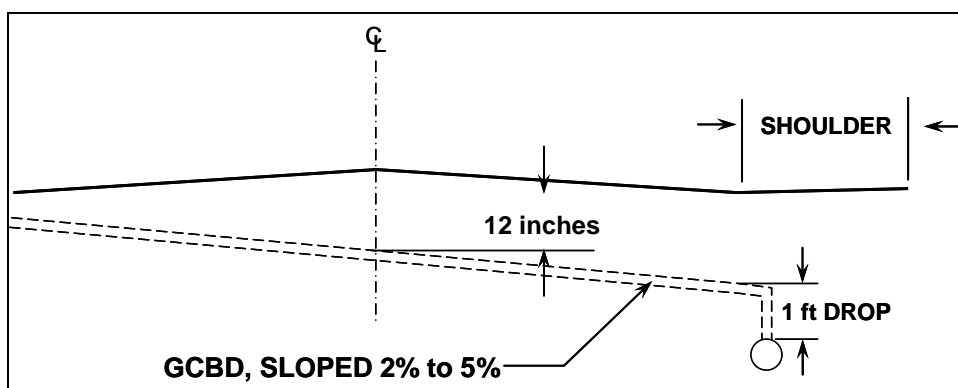


Figure 5. Geosynthetic Capillary Barrier Drain (GCBD).

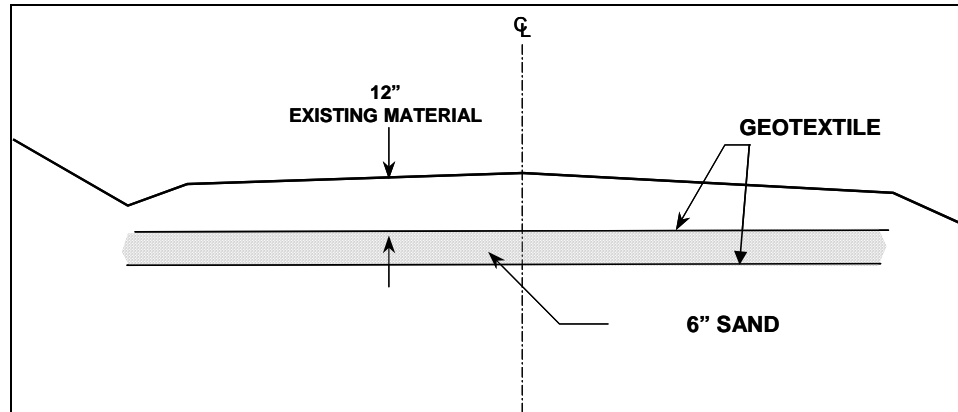


Figure 6. Geowrap.

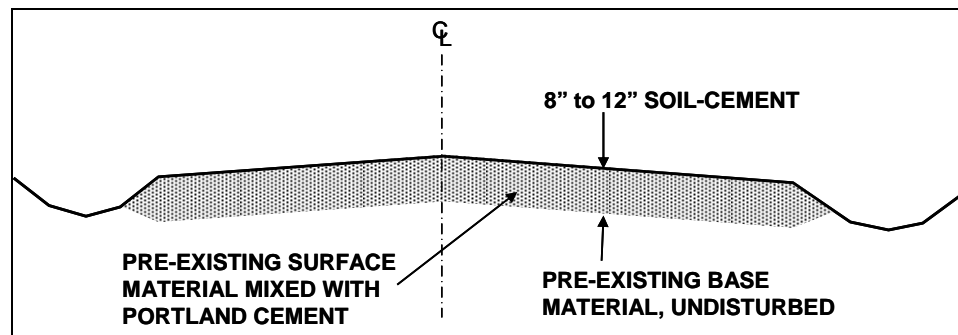


Figure 7. Cement stabilization.

### 3 SITE SELECTION

In the summer of 1998, UVM surveyed (by telephone) 154 towns in Vermont. Forty four percent of towns responding experienced moderate to severe mud season problems on one or more of their roads. As the project began, each of the team members discussed town participation with road commissioners in several towns near each researcher's home base. Following preliminary phone conversations and visits with town road commissioners and selectboards, three towns initially agreed to participate:

- Westford, proximate to UVM;
- Windsor, proximate to CRREL and GeoDesign; and
- South Royalton, proximate to ARA.

Initially, the interest of all three towns was high. This condition carried through in Westford and Windsor, but town officials in South Royalton became nonresponsive as the construction season approached. Thus, we entered the fall 2001 construction season with two towns participating.

Meanwhile, in Windsor and Westford, team members met with the road commissioners and selectboards to keep them informed of the process, the project goals, the contributions of materials made by industry representatives, and the construction efforts that would be required from the town road crews. This was an important phase because we did not want them to feel that there would be any surprises, unexpected costs, or inconveniences during their involvement with the project or when the project was over.

In late summer 2002, South Royalton definitively declined to participate, and the research team attempted to enlist the town of Bethel, whose officials were at first receptive. Unfortunately, planning and commitment for Bethel's participation was completed at about the time of the first snowfall, which rendered construction of improvements impractical because of the mixing of snow and soil that would have occurred. The project proceeded with the two towns of Westford and Windsor participating.

## 4 CONSTRUCTION

Town road crews and contractors constructed the test sections in October and November 2001. The Westford town road crew completed the work on Old Stage Road. Part of the work required renting a piece of equipment for mixing soil and cement. The Windsor town road crew installed two separator test sections on Hunt Road. However, they became pressed for time, so a local private contractor, Miller Construction Company, completed the remaining test sections.

The conditions during construction were dry and mild. The average total precipitation for Vermont for September through October 2001 was 8.66 in. This is significantly below average for that time of year, and the autumn months of 2001 were the 32<sup>nd</sup> most dry in the period from 1895 to 2004 (<http://lwf.ncdc.noaa.gov/oa/climate/research/cag3/vt.html>).

### 4.1 Windsor

Table 5 lists a short description of each test and control section built in Windsor. Two techniques were tried for the first time on Hunt Road—that of the “Geowrap,” conceived of by Benda, and the Geosynthetic Capillary Barrier Drain, or GCBD.

#### *Area 1*

The Windsor Town road crew installed the geotextile separator and the instrumentation for Area 1 on November 6, 2001. They constructed the test section one lane at a time in order to keep the road open. After scarifying the road surface to loosen the surface, they removed 12 in. of material from the eastbound lane with a road grader (creating windrows) and stockpiled it nearby. They rolled out a 75-in. length of geotextile and placed the stockpiled material back onto the geotextile with a loader and dump truck (Fig. 8). The vertical edge of the geotextile that was in contact with the middle windrow was left exposed after the surface material was replaced on the eastbound lane. The westbound lane was then constructed similarly, with the geotextile lengths overlapping in the middle of the road by about 30 in. (Fig. 8). Constructing the road in this manner, keeping one lane open at all times, resulted in the installation of a “wrinkled” geotextile separator (Fig. 9).

**Table 5. Areas, test, and control sections in Windsor.**

Area	Test or control section	Length (ft)	Depth of top thermocouple (in.)	Description
1	Control East (CE)	50	6	
	Separator	75	6	Geotextile separator placed 12 in. below road surface
	Control West (CW)	50	6	
2	Control East (CE)	100	8	
	Drain	100	8	Trench drain, parallel to road bed constructed of screenings* around a 4-in.-diameter PVC drain, wrapped in geotextile
	Grid	100	12	Biaxial geogrid placed 12 in. below the road surface
	Control West (CW)	75	8	
3	Control East (CE)	75	8	
	Cement	100	8	6% by weight cement added to road surface material to depth of 12 in.
	Control Middle (CM)	75	8	
	Geowrap	100	No thermocouples installed	"Sandwich" of 6 in. of clean sand with geotextiles on top and bottom, located 12–18 in. deep
	Control West (CW)	75	No thermocouples installed	
4	Control East (CE)	100	6	
	Separator	100	6	Geotextile separator placed 12 in. below road surface
	Control Middle (CM)	75	6	Three thermocouples strings installed in this section
	Geosynthetic Capillary Barrier Drain (GCBD)	100	6	GCBD placed 12 in. below road surface, sloped to one side and tied to a drain under the shoulder.
	Control West (CW)	75	6	

\* Screenings refers to material that is retained on a screen. In Windsor the screenings passed a 3-in. sieve and were retained on a 3/8-in. sieve.



**Figure 8. Installation of geotextile separator in Windsor, Area 1. Note “windrows” at edges where surface material was removed.**



**Figure 9. Geotextile separator in Windsor, Area 1, during construction. Note that there are numerous wrinkles.**

#### *Area 2*

Miller Construction Company built the geogrid test section on November 19, 2001. Windsor required that one lane of the road remain open at all times, so the grid was placed one lane at a time, and the test section was constructed by removing material with a Gradall excavator, rolling out the grid for a short distance and replacing the material (Fig. 10). This resulted in bunching of the geogrid at the center windrow and at the shoulder, as shown in Figure 10. The grid overlapped in the center of the road by about 12 in.

The drain test section was built on November 21, 2001. A 3.5-ft-deep by 2.0-ft-wide trench was excavated and lined with an 8-ft-wide geotextile (the same geotextile used as a separator). A bed of 4 in. of screenings was placed in the bottom of the trench, and the AASHTO M 252 Type C corrugated pipe, 4 in. in diameter, was placed in the center of the trench on top of the screenings. The screenings surrounded the pipe in the trench and were completely enclosed by the geotextile with a minimum of 3 in. of overlap (Fig. 11).

Holes and trenches for instrumentation in Area 2 were excavated with the Gradall. The top thermocouple was placed 12 in. deep in the geogrid test section and 8 in. deep in the remaining sections (Drainage, Control East, and Control West).



**Figure 10.** Installation of geogrid in Windsor, Area 2. The image is looking west; the eastbound lane was constructed first.



**Figure 11.** Installation of drainage in Windsor, Area 2. The image is looking west.

### *Area 3*

The “geowrap” section was built on November 26, 2001, by excavating 18 in., placing separator geotextile, placing a 6-in. layer of clean sand on the geotextile, and placing separator geotextile on top of that. The sand placed between the geotextile layers had less than 5% passing the #200 sieve. The geotextiles overlapped by about 18 in. (Fig. 12). Windsor closed the road for this construction, which resulted in a faster and higher-quality installation than when constructed one lane at a time. A loader and bulldozer were used to place the sand and surface material layers. This worked very well.



**Figure 12.** Top geotextile layer of geowrap during construction in Windsor, Area 3.

The cement-treated test section was built on November 28, 2001. Six inches of surface material was removed with the Gradall excavator, cement was then placed by hand on the exposed surface. The cement and soil were scarified to a depth of 6 in. to mix, and this was rolled with a Bomag roller for compaction. The surface soil was then replaced, and the process of applying cement, mixing, and compacting was repeated. There was no control of soil moisture during this construction.

Instrumentation in Area 3 was installed in the Control East (CE), Cement, and Control Middle (CM) test sections only. The top thermocouple was placed at a depth of 8 in.

#### *Area 4*

The Windsor road crew built the separator test section on November 8, 2001. There was only one 80-ft length of 15-ft-wide geotextile left for this project. This was placed in the middle of the road, from the top of the 100-ft-long test section (adjacent to Control East) (Fig. 13). The lanes are narrow, and this covered about 85–90% of the road surface. The geotextile was not wrinkled in this installation as it was in Area 1.



**Figure 13. Geotextile separator during construction in Windsor, Area 4.**

Miller Construction Company built the Geosynthetic Capillary Barrier Drain (GCBD) test section on November 20, 2001. Windsor closed the road for this construction. Twelve inches of road surface was excavated, and the special geocomposite (geotextile separator attached to the drainage net) was placed and then covered with the transport layer of the GCBD. The GCBD was placed at a 5% grade across the road, and the low end of the transport layer was placed in con-

tact with a pipe that was placed in an 18-in.-deep trench (Fig. 14). The lower 15 ft of the GCBD (adjacent to Control West) did not have a transport layer due to lack of material, and a geotextile separator was placed on top of the drainage net for the bottom (westernmost) 15 ft of the test section.

Applied Research Associates installed instrumentation in Area 4. The top-most thermocouples were located 6 in. below the surface in all of the Area 4 test sections. Three vertical thermocouple strings were installed in the middle control section (CM): one at the centerline (CM-CL), one in the center of the northernmost lane (CM-N), and one in the center of the southernmost lane (CM-S). Single strings were installed in the centers of all other test sections of Area 4.

Figures 15 and 16 show the locations of the Windsor test sections on air photos.



**Figure 14. G CBD during construction in Windsor, Area 4. Here the transport layer (white fabric) is being connected to drain pipe.**

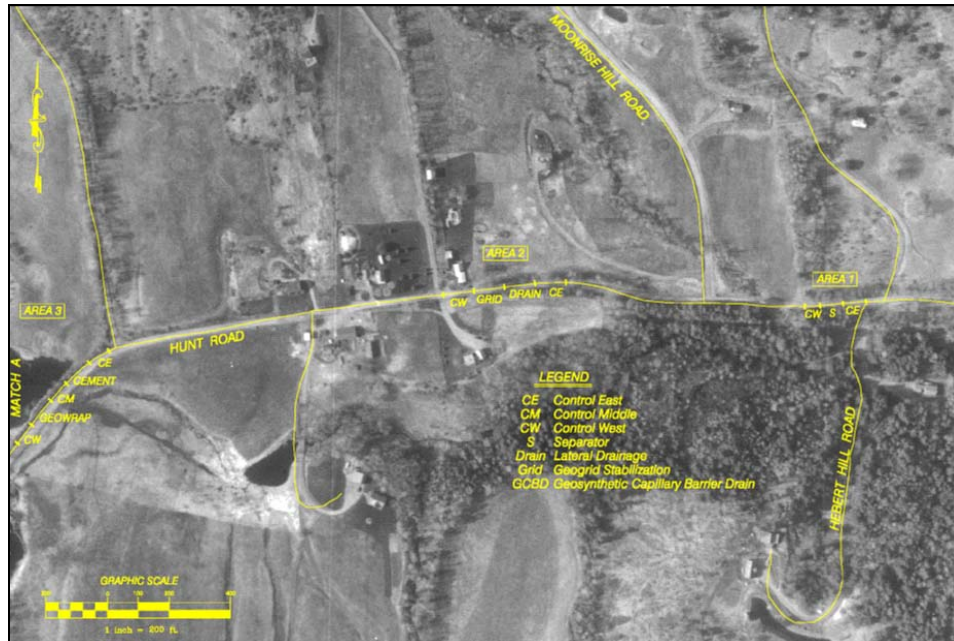


Figure 15. Air photo of Hunt Road, Windsor, showing Areas 1, 2, and 3.

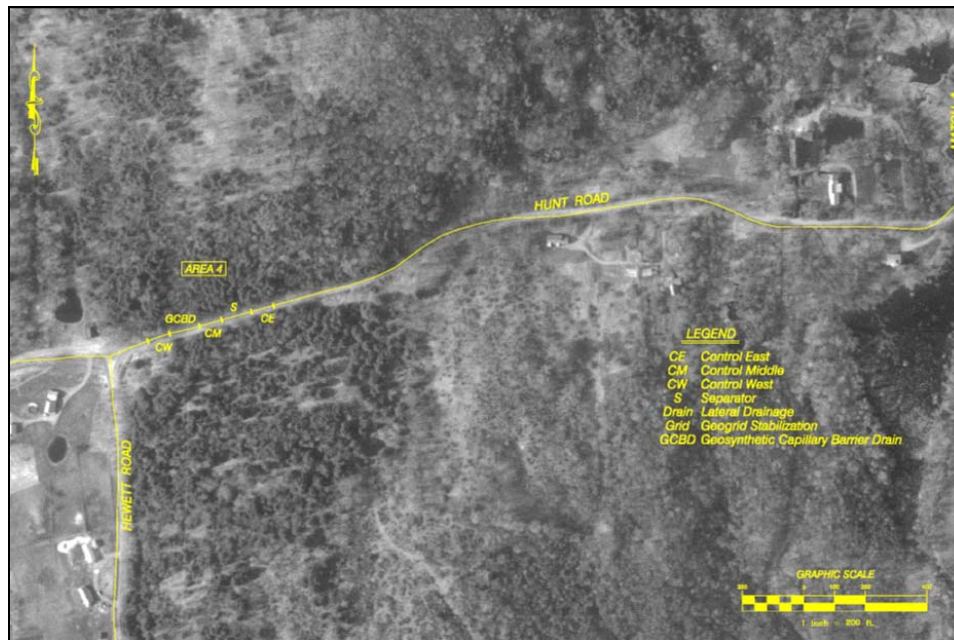


Figure 16. Air photo of Hunt Road, Windsor, showing Area 4.

## 4.2 Westford

Table 6 contains descriptions of the Westford test sections. Note that the shallowest thermocouple was placed 6 in. deep in all Westford test sections.

**Table 6. Test and control sections in Westford.**

Test or control section	Length (ft)	Description
Geocell 1	100	Geocells (cellular confinement), 6 in. thick, filled with Westford road gravel and sandwiched between two layers of geotextile separator, topped off with a surface course of 8 in. of road gravel
Control 1	100	Control between two geocell test sections
Geocell 2	100	Geocells (cellular confinement), 4 in. thick, filled with Westford road gravel and sandwiched between two layers of geotextile separator, topped with a surface course of 8 in. of road gravel.
Control 2	75	Control between Geocell 2 and Drain test sections.
Drain	100	Edge curtain drain installed on the east side of the road, consisting of a PVC perforated pipe encapsulated in clean, crushed stone and wrapped in a geotextile; the drain begins 4 ft below the road surface and daylights in the ditch at the north end of the section
Control 3	50	Control between the Drain and Geogrid test sections
Geogrid	100	A layer of geogrid placed 12 in. below the road surface; the northbound lane is Tensar® BX 1200, and the southbound lane is BX 1100
Control 4	75	Control between Geogrid and Cement test sections
Cement	100	Cement stabilization of the near-surface road materials; original mix design for 6% by weight of cement in the upper 12 in. of material but equipment limitations resulted in approximately 8–9% in the upper 8 in.; after first year an additional 4 in. of unstabilized road surface was added to control dust

### *Geocell 1*

The Westford town road crew installed the first cellular confinement system test section on October 29, 2001. The test section was constructed across both lanes at the same time, facilitated by closing the road. The work schedule allowed for school bus passage in the morning prior to closing the road, and work was completed in time for the afternoon school bus return trip. Removing approximately 12–14 in. of road material and stockpiling it for later use prepared the test section. A geotextile separator was placed on the excavated surface, and the 6-in.-deep cells were stretched into place in 8-ft sections. Relatively clean gravel

(AASHTO Classification A-1-a) was placed in the expanded cells using a front-end loader (Fig. 17). After the cells were filled with gravel, a second layer of geotextile separator was placed over the top. Then 8 in. of the original road surface material was placed over the installation and graded for traffic. ARA personnel coordinated the installation of the thermocouples in the center of the 100-ft length of the test section.



**Figure 17. Geocell test section during construction.**

#### *Geocell 2*

The Westford town road crew constructed the second cellular confinement system test section on October 30, 2001. This construction was essentially the same as that for Geocell 1, with the exception that the cell layer was 4 in. thick. The cells were filled with the same gravel as before, and a layer of geotextile separator was placed above and below the cell layer.

#### *Drain*

The Westford town road crew constructed the drainage test section on October 31, 2001. It consists of a buried side curtain drain adjacent to one side of the road surface (Fig. 18). A trench was first excavated to a depth of approximately 3 ft below the bottom of the roadside ditch. A geotextile was then draped in the trench, and clean, crushed stone bedding was placed at the base of the lined trench. A 4-in.-diameter perforated PVC pipe was then placed on the bedding, and the remainder of the trench was filled with crushed stone. The geotextile



**Figure 18. Westford Drain test section during construction.**

was then wrapped over the top of the stone to enclose this “composite” drain, and then some topsoil was placed over the top to re-establish the grass-lined ditch. The drain “daylighted” at the end of the 100-ft test section. The ARA personnel placed thermocouples at the center of the 100-ft length of test section.

#### *Geogrid*

The Geogrid test section was built on November 1, 2001. Construction of this 100-ft test section involved first removing 12 in. of road surface and temporarily stockpiling the material. Two different strengths of biaxial geogrid were used in the test section. Both were Tensar<sup>®</sup> products. The “weaker” grid (BX 1100) was placed under the southbound lane, and the “stronger” grid (BX 1200) was placed under the northbound lane of the road. The road crew stretched the grid during placement as best they could, since the manufacturer recommends that the product be installed in such a way as to be actively in tension. The original road gravel was placed over the geogrid layers as they were held in their stretched condition (Fig. 19). A thermocouple string was placed in the middle of the 100-ft test section.



**Figure 19. Westford Geogrid test section during construction, showing original road surface material being placed on the grid.**

#### *Cement Stabilization*

The cement-stabilized test section was constructed on November 6, 2001, by the Westford town road crew. The intent for this section was to mix approximately 6% by weight of cement with the upper 12 in. of the existing road gravel material. The end product more likely resulted in 10–12% by weight of cement mixed with the upper 6–8 in. of road gravel. This was due to the maximum effective depth of mixing that could be accomplished by the rental Bomag machine (Fig. 20). The plan for this section was that no excavation would be required and that cement dispersed on the surface could be mixed thoroughly by the rotary tiller to the desired depth. The mixing was complete and thorough but to a shallower depth than planned. After mixing, the surface was rolled and compacted before traffic returned to the road. Thermocouples were also installed in this test section as in the others.

#### *Control Sections*

As construction of the test sections occurred in sequence, thermocouples were also installed in the interspersed control sections that separated the test sections. Control 1 was located between Geocell 1 and Geocell 2, Control 2 was between Geocell 2 and Drain, Control 3 was between Drain and Geogrid, and Control 4 was between Geogrid and Cement.

Figure 21 shows the locations of the Westford test sections on an air photo.



Figure 20. Westford Cement test section during construction, showing original road surface material being mixed with cement to a depth of 8 in.

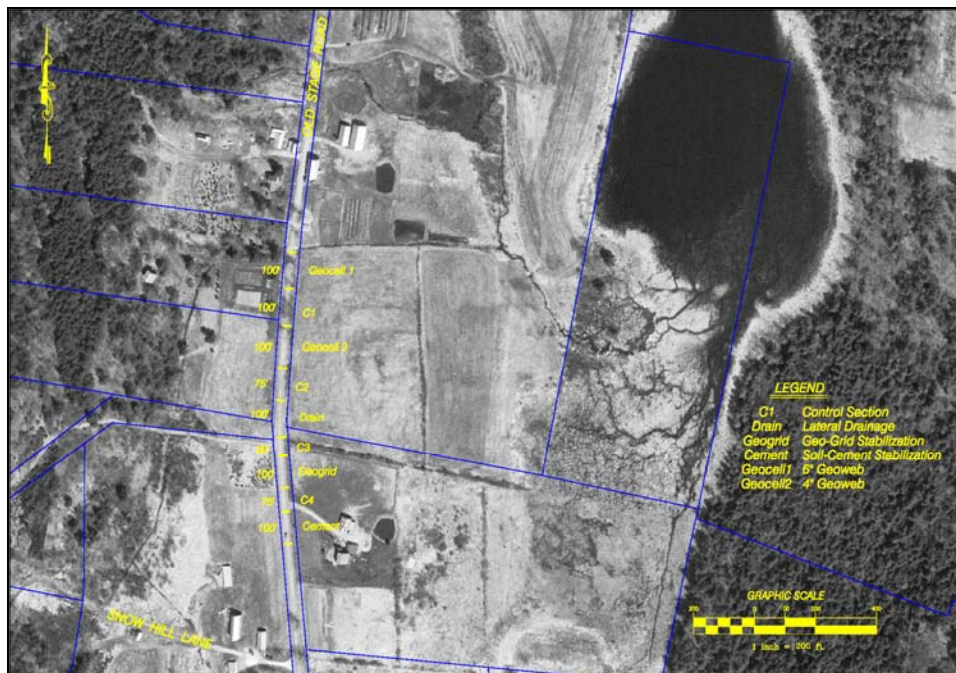


Figure 21. Air photo of Old Stage Road in Westford, showing test and control sections.

## 5 CHARACTERIZATION AND MONITORING

We performed baseline soil characterization prior to and during construction of the test sections. Soil and road conditions were monitored during spring thaw in 2002 and 2003 using visual inspection, measurements of rutting, photographic documentation, written descriptions, and dynamic cone penetrometer testing.

### 5.1 Laboratory Evaluation

Prior to construction of the test sections, we collected and tested soil samples from various depths in the study area roadways. The testing employed ASTM laboratory methods to determine grain size distributions. Soil classification information is summarized in Table 7.

**Table 7. Soil classification information for Hunt Road and Old Stage Road.**

Sample	USCS classification	AASHTO classification	Percentage passing #200	Percentage finer than 0.05 mm*
Windsor, Area 1, Top 12 in., collected 10/02, A	SM, Silty Sand	A-1-b	17.8	14.5
Windsor, Area 1, Top 12 in., collected 10/02, B	SM, Silty Sand	A-2-4	23.2	19.2
Windsor Town Borrow Pit, 11/20/01	SM, Silty Sand	A-1-b	7.5	Not determined
Windsor, Area 2, Surface, 4/16/03	SM, Silty Sand	A-1-b	11.2	Not determined
Westford, Surface	GP-GS, Poorly graded Sand and Gravel	A-1-a	1.9	Not determined

\* Soils containing >5% finer than 0.05 mm are considered to be frost susceptible (Casagrande 1931).

### 5.2 Dynamic Cone Penetrometer Testing

Dynamic cone penetrometer (DCP) tests were used to estimate the strength of the upper road layers during spring thaw. The DCP test is performed by driving a rod with a conical, steel tip into the ground using a slide hammer and measuring the depth of penetration after each blow. The test produces a penetration index (PI) value that varies with depth and is correlated to either the California Bearing Ratio (CBR) or resilient modulus ( $M_r$ ), both of which are used to design and evaluate roadways. We regularly conducted DCP testing in the spring of 2002 and the spring of 2003 during rapid changes in road conditions. We

collected most DCP data using a DCP data acquisition system (DCP-DAS) (Fig. 22). The DCP-DAS counts blows and measures displacement during a DCP test, storing the data for several tests in digital data files that can be later downloaded to a PC.



**Figure 22. Dynamic cone penetrometer (DCP) for determining soil strength as a function of depth.**

### **5.3 Soil Moisture Resistivity and Temperature (SMRT) Probe Profiling**

In addition to DCP testing, we drove an instrumented probe (SMRT probe) to acquire profiles of soil moisture, electrical resistivity, and temperature during 2003 in Westford. An example of such data is shown in Figure 23.

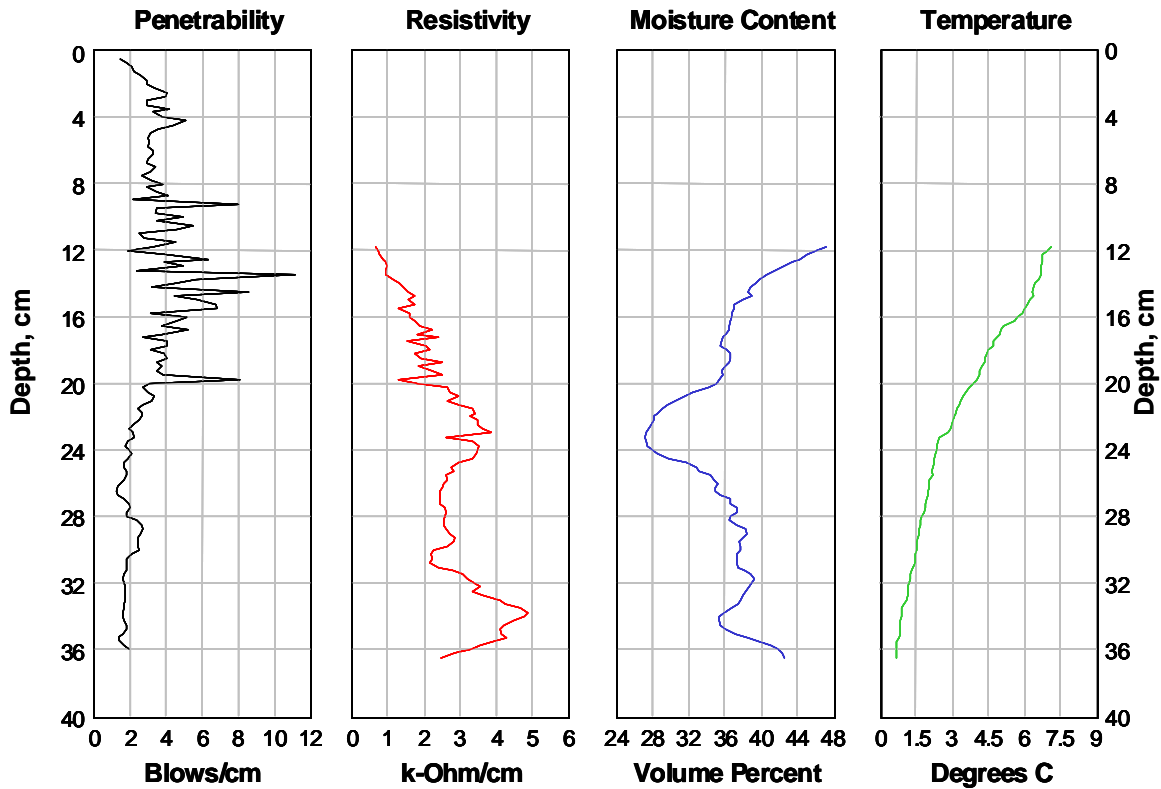


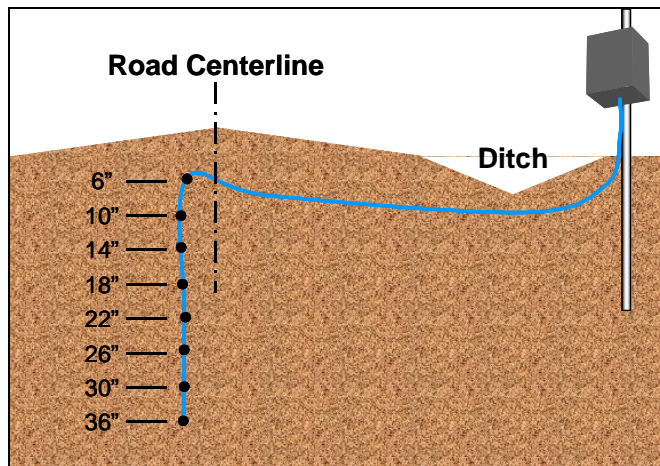
Figure 23. Sample soil moisture, temperature, and resistivity profile obtained using a SMRT probe.

#### 5.4 Sensors

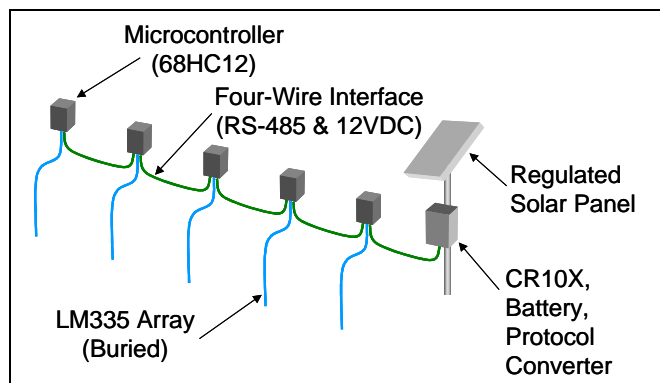
We monitored soil temperatures at multiple depths in the test and control sections. Each thermocouple string installed is composed of eight thermocouples separated by 4 in. each, with 6 in. between the last two thermocouples (Fig. 24). They were placed in the roadbed at a minimum depth of 6 to 12 in. below grade. A Campbell Scientific CR10X datalogger collected data from the thermocouples at each site via communication with a microcontroller board connected to each array. The communications were carried over an RS-485 multi-drop serial network. A schematic of the instrument installation at each site is shown in Figure 25.

For the CRREL thermocouples placed in test and control sections at Areas 1, 2, and 3 in Windsor, a CR10X powered by a solar panel collected data that we periodically downloaded to a portable computer. (The solar panel in Area 3 in Windsor never supplied enough power to keep the datalogger charged, so very few data were recovered from that site.) Hourly measurements of temperature at

every sensor, as well as datalogger temperature (essentially air temperature) and battery voltage, were obtained and stored in the onboard non-volatile memory of each CR10X. Temperature data for each of the CRREL-monitored test sections are presented for both thaw seasons in Section 6.



**Figure 24. Schematic of in situ thermocouples.**



**Figure 25. Schematic of test site instrumentation.**

The ARA instrumentation became operational at Windsor and Westford in early January 2002. An Access database was developed to store and manage collected data, sensor calibrations, and deployment information for the ARA instrumentation.

Plots of temperature versus time at each monitored depth in each instrumented section appear in Appendix A for all data collected. An example plot from Appendix A is shown in Figure 26.

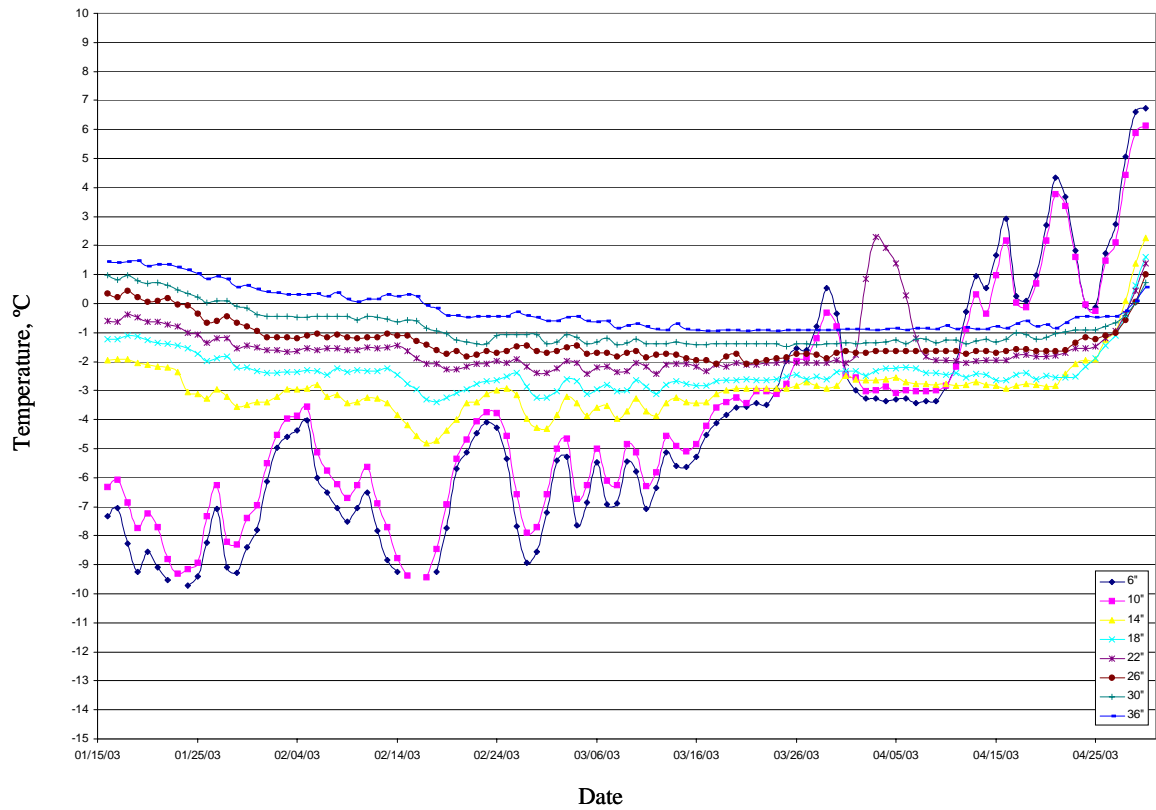


Figure 26. Example plot of temperature monitoring data, obtained from the GCBD test section in Windsor, spring 2003.

## 6 RESULTS

### 6.1 Freezing seasons for 2001-02 and 2002-03

The freezing index is a combined measure of the duration and magnitude of freezing temperatures during a freezing season. It is determined by measuring the number of degree-days ( $^{\circ}\text{C}$ ) between the highest and lowest points on the cumulative degree-days vs. time curve for one season (typically determined for mean daily air temperatures measured 4.5 ft above the ground). An average daily temperature of  $1^{\circ}\text{C}$  for one day is one degree-day; an average daily temperature of  $-2^{\circ}\text{C}$  for one day is negative two degree-days. Graphing cumulative average daily temperatures (in  $^{\circ}\text{C}$ ) for the duration of the freezing season yields a maximum and a minimum value, and the distance between them (in degree-days) is the freezing index (e.g., Fig. 27 and 28). The freezing season begins when the cumulative degree-day curve slopes downward and ends when it begins to slope upward (e.g., Berg and Johnson 1983).

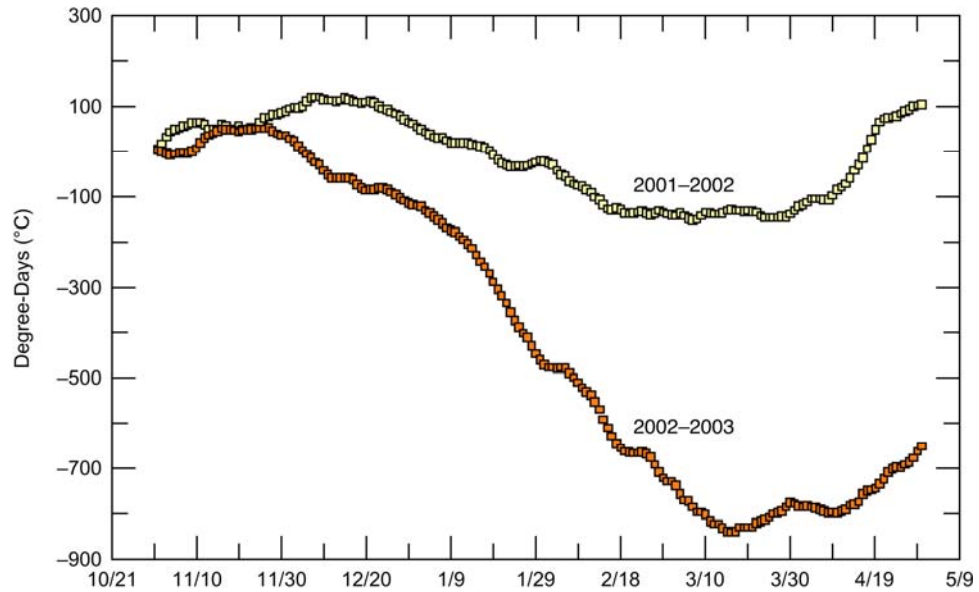
The two freezing seasons of 2002 and 2003 were quite different (Table 8). The 2001-02 year was very mild with respect to duration and intensity, and the 2002-03 season was about equal to the design freezing index (most severe winter in a 30-year period), estimated at  $890^{\circ}\text{C}$  freezing days for Windsor (Berg and Johnson 1983). These conditions led to a relatively mild thaw season in 2002 and a more severe season in 2003.

Figures 27 and 28 are based on mean daily temperatures recorded by the National Weather Service (NWS) for the weather stations in Newport, NH, (the closest NWS station to Windsor) and Essex Junction, VT (the closest NWS station to Westford). The 30-year mean freezing index for Windsor is about  $560^{\circ}\text{C}$  freezing days (Berg and Johnson 1983). The 30-year mean freezing index for the Burlington area is  $766^{\circ}\text{C}$  freezing days, and the design freezing index is  $1070^{\circ}\text{C}$  freezing days.

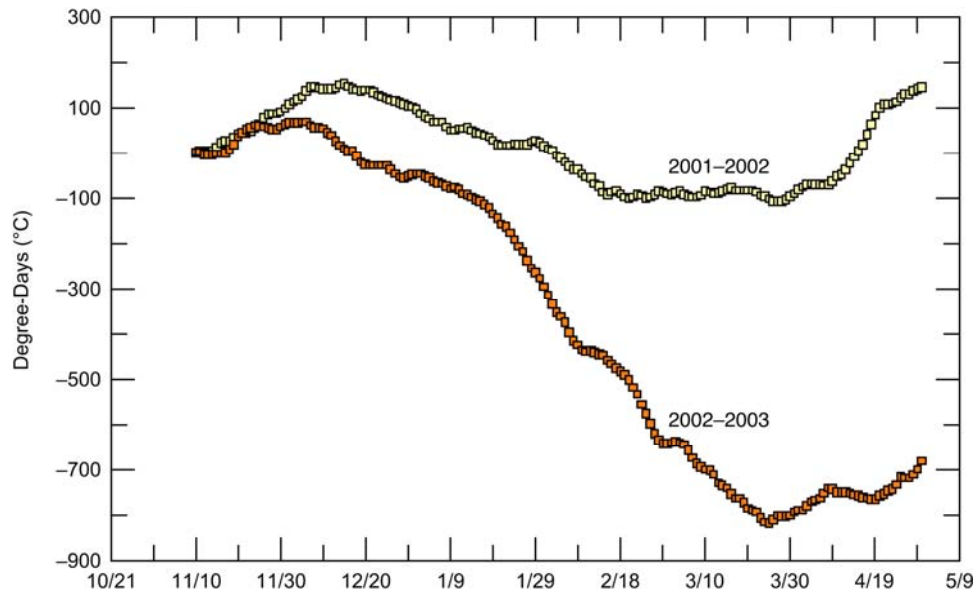
**Table 8. Freezing season data, based on National Weather Service data, Newport, NH, and Essex Junction, VT.**

Season, location	Freezing index ( $^{\circ}\text{C}$ -days)	Start date, freezing	End date, freezing*	Duration (days)
2001-02, Newport	272	12/08/01	3/10/02	89
2001-02, Essex Jct.	261	12/15/01	3/27/02	107
2002-03, Newport	892	11/27/02	3/16/03	109
2002-03, Essex Jct.	884	11/26/02	3/16/03	120

\*Date of maximum cumulative degree days below freezing.



**Figure 27. Cumulative degree-days for Newport, NH, for 2001-02 and 2002-03 freezing seasons.**



**Figure 28. Cumulative degree-days for Essex Junction, VT, for 2001-02 and 2002-03 freezing seasons.**

## 6.2 Overview of thaw monitoring program

Appendix A contains daily average temperatures in the ground collected on all test sections for the latter part of the freezing season through the thaw season each year. Daily average values for the shallowest thermocouples are shown in figures contained in the following section.

Once the data for the middle control section of Area 4 in Windsor (CM) were screened for quality, there was little available for the 2002 season, and some of the locations were missing from the 2003 thaw season. The datalogger in Area 3 of Windsor did not remain charged for any length of time, and consequently temperatures were only available for a few days in late February 2002 and none were obtained 2003.

Appendix B contains images of the Windsor test sections during thaw.

California Bearing Ratio (CBR) determinations were calculated from the dynamic cone penetrometer values according to the U.S. Army Corps of Engineers empirical correlation (Webster et al. 1992):

$$\text{CBR}(\%) = (292)/(\text{mm/blow})^{1.12}.$$

For analysis, CBR determinations were considered more heavily than rutting and other indicators of surface distress. Appendix C, supplied as Excel files on a CD, contains CBR determinations for every DCP test run in Windsor. The data are available from the first author.

In Westford, temperatures and water contents were recorded during DCP tests using the SMRT probe on some test sections for the 2003 season. These are reported in Appendix D.

Every test section that degraded developed ruts. This was documented carefully in Windsor. Potholes formed regularly in only one test area—Area 3 in Windsor. Thus, rutting data are presented for all Windsor test sections below; for Area 3, both rutting and pothole data are presented.

Road maintenance (adding material and/or grading) was hard to document because of irregular communication with road maintenance crews. However, newly added material was observed to influence rutting on some days. Sometimes it improved the road surface and CBR determinations, and other times it seriously degraded performance, resulting in deeper rutting with more material heave between the ruts.

### 6.3 Incomplete data recovery

The temperature records contain significant gaps. For times during which some arrays returned data but others did not, the failure of individual array controllers was responsible for the gaps. At other times, site-wide gaps occurred for two reasons. First, sometimes miscommunication between the team members responsible for data management and those conducting field visits resulted in a failure to download the data when needed. At other times, the central CR10X datalogger at a site failed, and the problem was not discovered until the next scheduled data download.

Our experience with incomplete data recovery on this project has led us to make recommendations for future projects that involve unattended long-term monitoring of field sites. We recommend that all responsibility for data collection be held by one organization or participant. If that is not practical, then remote datalogger servicing and other field activities should be more frequently coordinated. Such coordination should especially include notification between parties when intended downloads of data are delayed, postponed, or otherwise prevented from occurring on schedule. In addition, data should be downloaded from dataloggers at much more frequent intervals than the datalogger memory is capable of handling. Data buffer overrun caused by missed downloads is not the only risk. On this project we found that equipment malfunctions prevented data recovery more often than buffer overruns. More frequent checking (on the order of bi-weekly) could have prevented some losses or expedited recovery from most of the datalogger downtime that occurred during this project.

### 6.4 Windsor

The four Windsor test areas thawed at somewhat different times. For example, Area 3 thawed sooner than the other three test sections. As a result, they were sometimes monitored on different dates, and on some dates, only visual inspection was completed. Appendix B contains at least two images for each test section for every day on which it was monitored.

In 2002, monitoring of Windsor began on February 25 and ended on April 2. Temperatures measured by the NWS in Newport, NH, indicate that there were five times within that period when the average daily temperature fell below 0°C: February 28–March 2, March 4–7, March 11–12, March 17–25, and March 31–April 1. In 2003, monitoring began on March 17 and ended on April 15, and the mean daily temperature measured by NWS in Newport indicates freezing average temperatures on March 19–20, April 2–3, and April 4–10.

Datalogger enclosure temperatures correlate well with temperatures recorded by the NWS. In addition, all of the shallow thermocouples are quite responsive to changes in the air temperature. Differences between test section temperatures at shallow depths should not be assigned too much significance because of uncertainty associated with the exact depth of placement caused by differences in compaction during placement as well as maintenance practices after construction.

The construction in late 2001 apparently influenced some results during the spring thaw in 2002, as several potholes developed over the location of instrumentation in some sections during the monitoring period. This was probably caused by the difficulty in compacting soil over the thermocouple to the same density as the surrounding undisturbed soil. As discussed below, temperatures recorded in Windsor suggest that soil in newly constructed test sections was less dense during 2002. By 2003, there was little evidence of this.

One general observation during monitoring was that on sunny days the surface of the road that remained in the shade retained a lot of moisture compared to the road surface exposed to the sun (Fig. 29). This sometimes made it difficult to differentiate improvements due to treatment from improved performance due to sun exposure if the border between shade and sun was at or near a section edge.



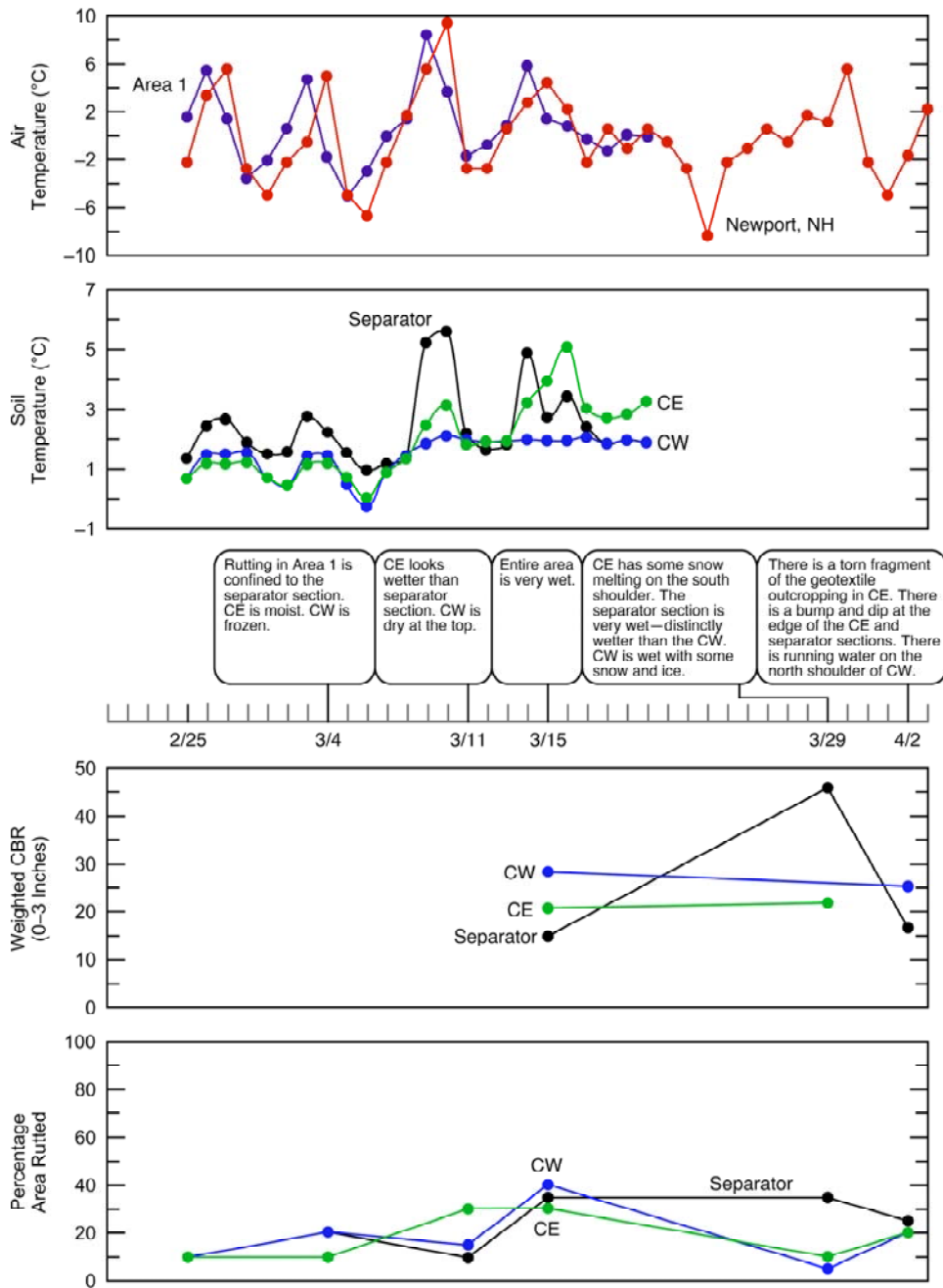
**Figure 29. Control East (CE) of Area 4 on April 2, 2002, showing the differences in moisture content of the road surface due to degree of sun exposure.**

On March 4, 2002, in Area 4, we observed that adding “gravel” to a section of the road that was badly rutted actually worsened the condition of the road—the added material resulted in more mud that then heaved and rutted (Fig. 30). A similar condition occurred at Area 2 on April 8, 2003, when added material made the road temporarily impassable to passenger vehicles. This appeared to be because the added material mixed with the over-saturated road surface material, resulting in an increased volume of saturated material (i.e., according to the old adage that “mixing a bucket of gravel with a bucket of mud makes two buckets of mud.”)

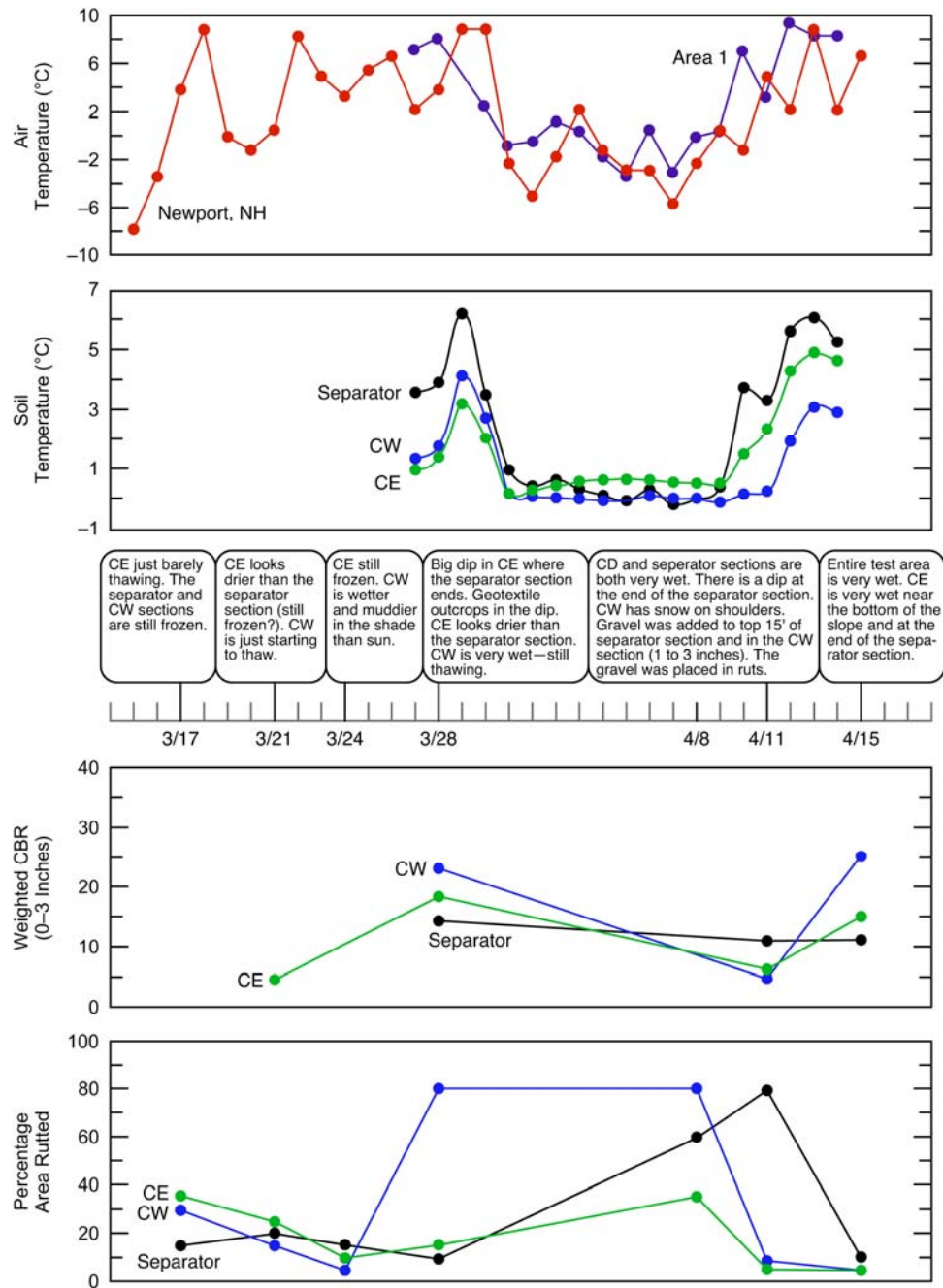


**Figure 30. Area 4, looking west, after about 6 in. of “gravel” was added on April 2, 2002. Adding the gravel resulted in deeper ruts.**

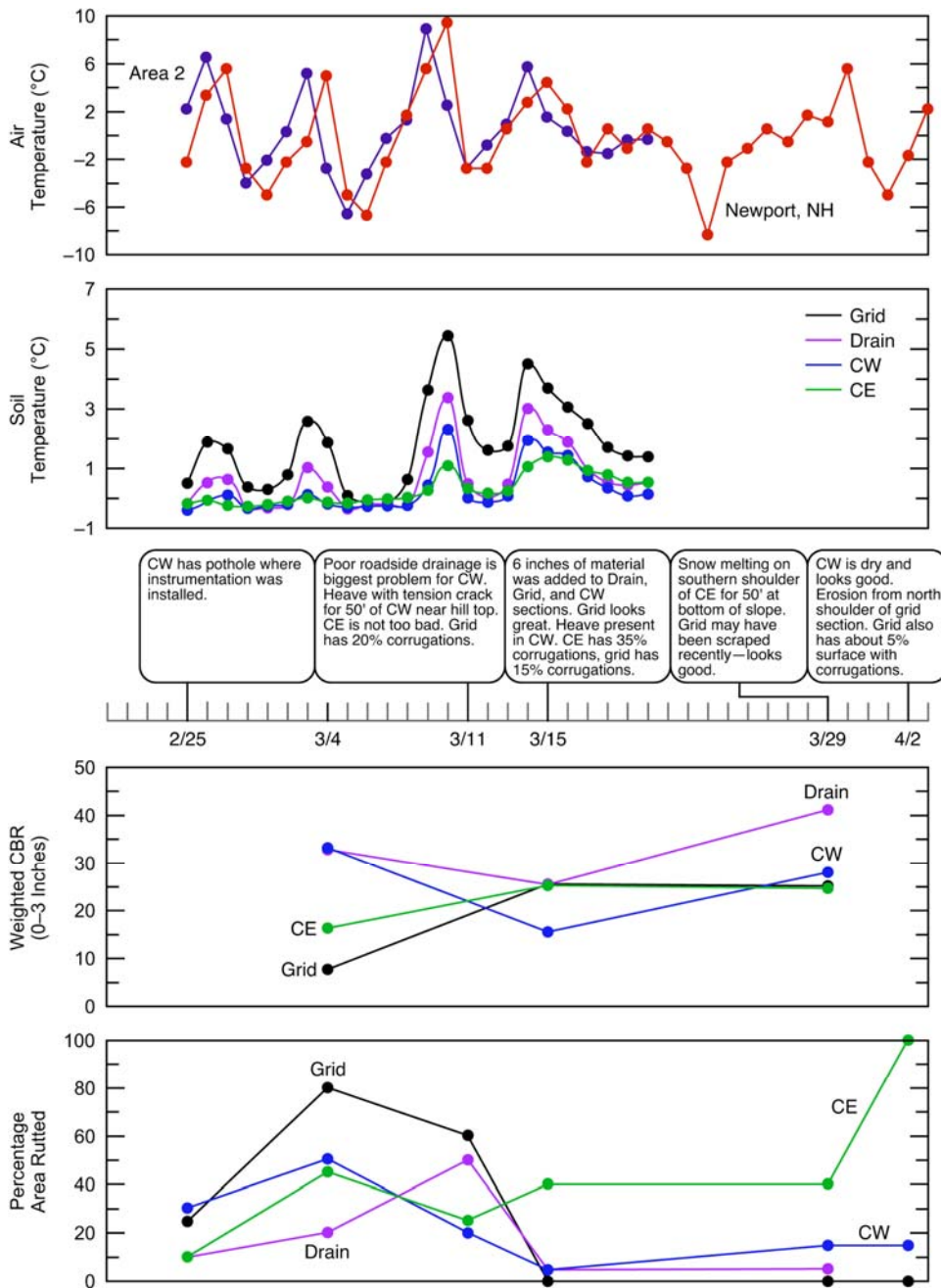
The following sections provide information and data for February 25 to April 3, 2002, and for March 14 to April 18, 2003, for Areas 1 through 4 (Fig. 31–34). The information for each section for each year is summarized on one figure, comprising a series of graphs and a timeline. The average daily temperatures recorded in the datalogger enclosure and the mean daily temperatures measured by the NWS in Newport, NH, are shown on the top graph. Daily average temperatures at the shallowest thermocouples in the test and control sections are shown on the second graph from the top. Note that degradation of the road surface and rutting occurred prior to the indication of thawed temperatures at the 6 in. depth and that thawed conditions existed above shallow thermocouples on most dates in which the test sections were monitored. Comments recorded during inspections are shown on the timeline, and average weighted CBR values and percentages of the test section covered by rutting are shown in the bottom two graphs, respectively. For Area 3, there were only a few records of air and soil temperatures successfully recorded; therefore, there are no soil temperature graphs for this section.



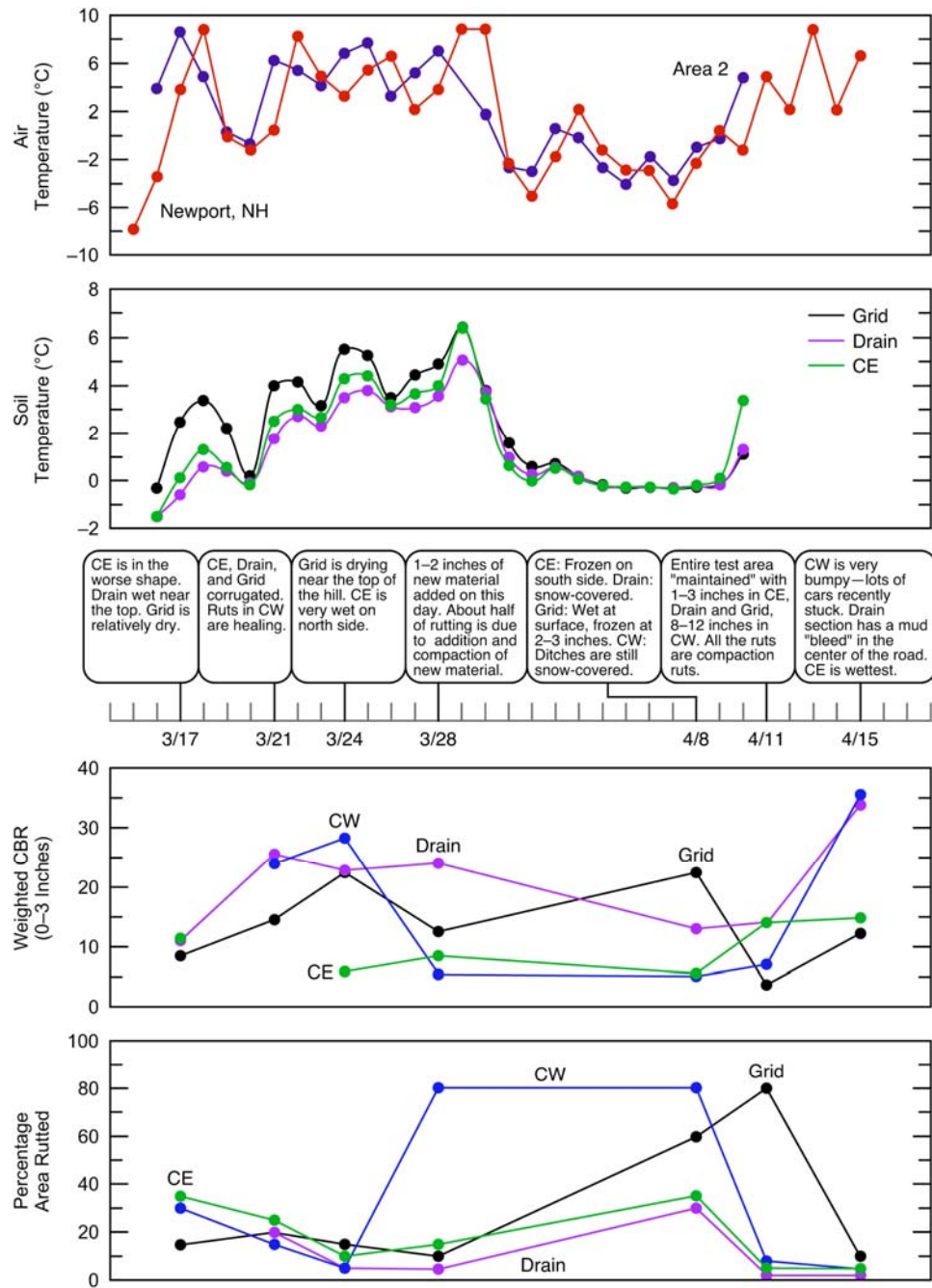
**Figure 31. Air temperatures at Newport and datalogger enclosure temperature (top graph), temperature measurements in the soil at 6 in. depth (second from top), annotated timeline, weighted CBR determinations for the top 3 in. of the road surface, and percentage of the test section rutted for Area 1, 2002 mud season.**



**Figure 32. Air temperatures at Newport and datalogger enclosure temperature (top graph), temperature measurements in the soil at 6 in. depth, annotated timeline, weighted CBR determinations for the top 3 in. of the road surface, and percentage of the test section rutted for Area 1, 2003 mud season.**



**Figure 33. Air temperatures at Newport and datalogger enclosure temperature (top graph), temperature measurements in the soil at 8 or 12 in. depth (for Grid section), annotated timeline, weighted CBR determinations for the top 3 in. of the road surface, and percentage of the test section rutted for Area 2, 2002 mud season.**



**Figure 34. Air temperatures at Newport and datalogger enclosure temperature (top graph), temperature measurements in the soil at 8 or 12 in. depth (for Grid section), annotated timeline, weighted CBR determinations for the top 3 in. of the road surface, and percentage of the test section rutted for Area 2, 2003 mud season.**

### *Area 1*

In Area 1, thawing progressed from the CE section to the Separator test section to the CW section both years. In 2002, there was no date monitored during spring thaw in which the shallowest thermocouple in the CW section was not indicating a freezing daily average temperature.

In 2003, the CE test section shallow thermocouple indicated thawed conditions from March 27 onward. The shallowest thermocouple in the Separator section indicated freezing on April 5, and the CW test section was frozen (at the 6-in. depth) on April 4 and 5.

The temperatures recorded in the Separator test section were more responsive to the changes in the air temperatures for both years (Fig. 31 and 32). This would result if the thermocouple in the Separator section was shallower or if the soil surrounding the thermocouple was less dense and/or drier than the soil at the same depths in the other test sections. On March 11, 2002, the Separator section appeared to be significantly drier than the CE; however, this was not observed on other monitoring dates.

The presence of the geotextile separator did not result in apparent improvement in the road section in either year. In 2002, the Separator section had a lower weighted CBR value than the adjacent control sections on March 15, a higher value than CE on March 29, and a lower value again on April 2; however, the value obtained on March 29 is suspect because much of the road was frozen on that day. In 2003 the Separator section had lower weighted CBR values than both the controls on two days and higher values on one day. The Separator section had no notable improved performance with respect to rut development in 2002. In 2003 it had more rutting on April 11 than the two controls, but on March 28 it had significantly less rutting than the CW.

### *Area 2*

Area 2 did not thaw upslope as did Area 1. Thermocouple data from 2002 indicate that at depths of 8–12 in. the ground was frozen in at least one of the sections from February 25 to March 1, from March 3 to March 7, and from March 10 to March 12 (Fig. 33).

The Grid section was quite responsive to air temperature changes in 2002 but less so in 2003 (Fig. 33 and 34). In 2002 the Grid section was significantly warmer than the other sections during the thaw season and thawed out sooner than the rest of the test sections in 2002. It was completely thawed (all thermocouples above freezing) on March 8, compared to complete thaw for the CE section on March 9. The data suggest that the grid section was less dense and/or dry in 2002 compared to the other Area 2 test sections.

In 2003, the Grid section's temperatures were much more similar to the other test sections. The Drain and CE's shallowest thermocouples were above freezing from March 17 to April 3, while the Grid section's shallowest thermocouple indicated that thawed conditions started on March 18 and lasted until April 3. (The CW thermocouple string was cut by a grader in early March.) Constant temperatures near freezing occurred from April 3 to 9 in the CE, Drain, and Grid sections, indicating phase change (freezing and thawing).

CBR readings and rut measurements in 2002 suggest a slightly improved performance in the Drain section and poor performance of the Grid section compared to the controls. Early in the thaw season of 2002, e.g. March 4, the Grid section was particularly distressed compared to the other sections, in which the surface had not been disturbed by construction during the previous fall (Fig. 35). In 2003 there is no evidence of either the Grid or Drain sections performing better or worse than the adjacent control sections. The improved CBR reading on April 8, 2003, of the Grid and Drain sections compared to the two controls must be discounted because of the presence of frozen soil at a few inches depth.

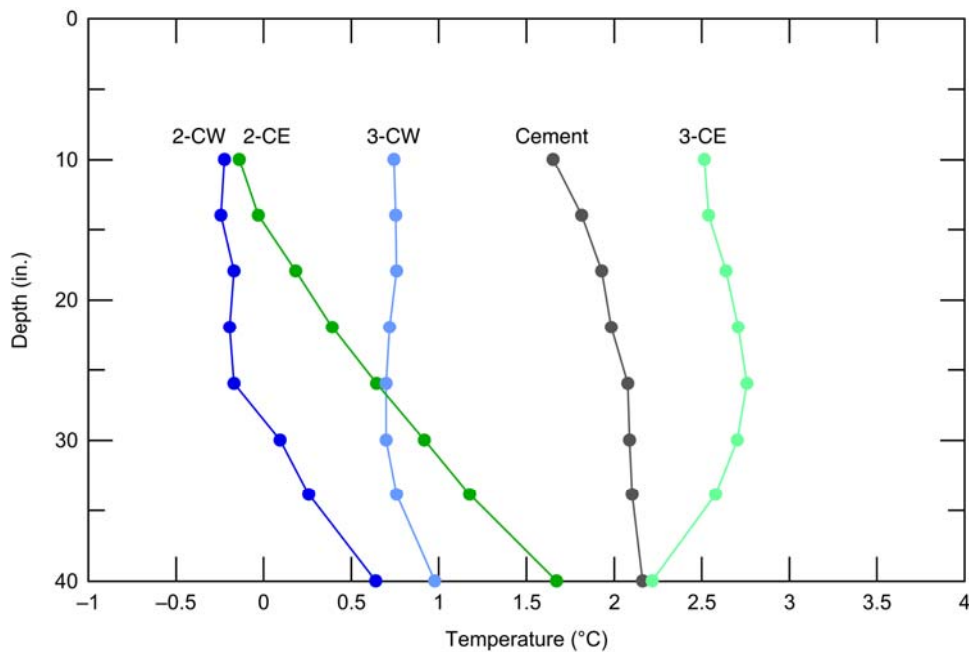


**Figure 35. Corrugations and potholes on the Grid section, Area 2, March 4, 2002. The Drain section is visible in the background, showing little surface distress.**

### *Area 3*

Area 3 is flat, has considerable sun exposure, and thawed more quickly than Areas 1, 2, and 4, which were all sloped and had many shaded zones. Although problems with the datalogger prevented temperatures from being recorded con-

sistently, the temperatures from Area 3 that were recorded on March 12, 2002, the only day for which temperature averages could be determined, indicate that the section was completely thawed, whereas Areas 1 and 2 still had considerable freezing (Fig. 36). Average datalogger enclosure temperatures on March 12, 2002, were  $-0.7^{\circ}\text{C}$  for Area 1,  $-0.8^{\circ}\text{C}$  for Area 2, and  $+4.3^{\circ}\text{C}$  for Area 3. During site visits, we observed that Area 3 thawed from east to west, with CE section thawing first and CW thawing last.



**Figure 36. Temperature profiles on March 12, 2002, in test sections located in Areas 2 and 3 in Windsor, Vermont.**

The performance of the Cement and the Geowrap sections stands out, both with respect to the CBR determinations and with respect to the rut development (Fig. 37 and 38). These sections were often visibly significantly drier at the surface than the adjacent control sections (Fig. 39 and 40). However, sometimes they contained as many potholes as the adjacent controls. The Cement section always had high CBR values near the surface, associated with relatively low rut formation. The Geowrap section recovered more rapidly than the two adjacent control sections (CM and CW). CBR determinations for the Geowrap section were similar to those of the control sections earlier in the thaw season, but the values rose more quickly over time.

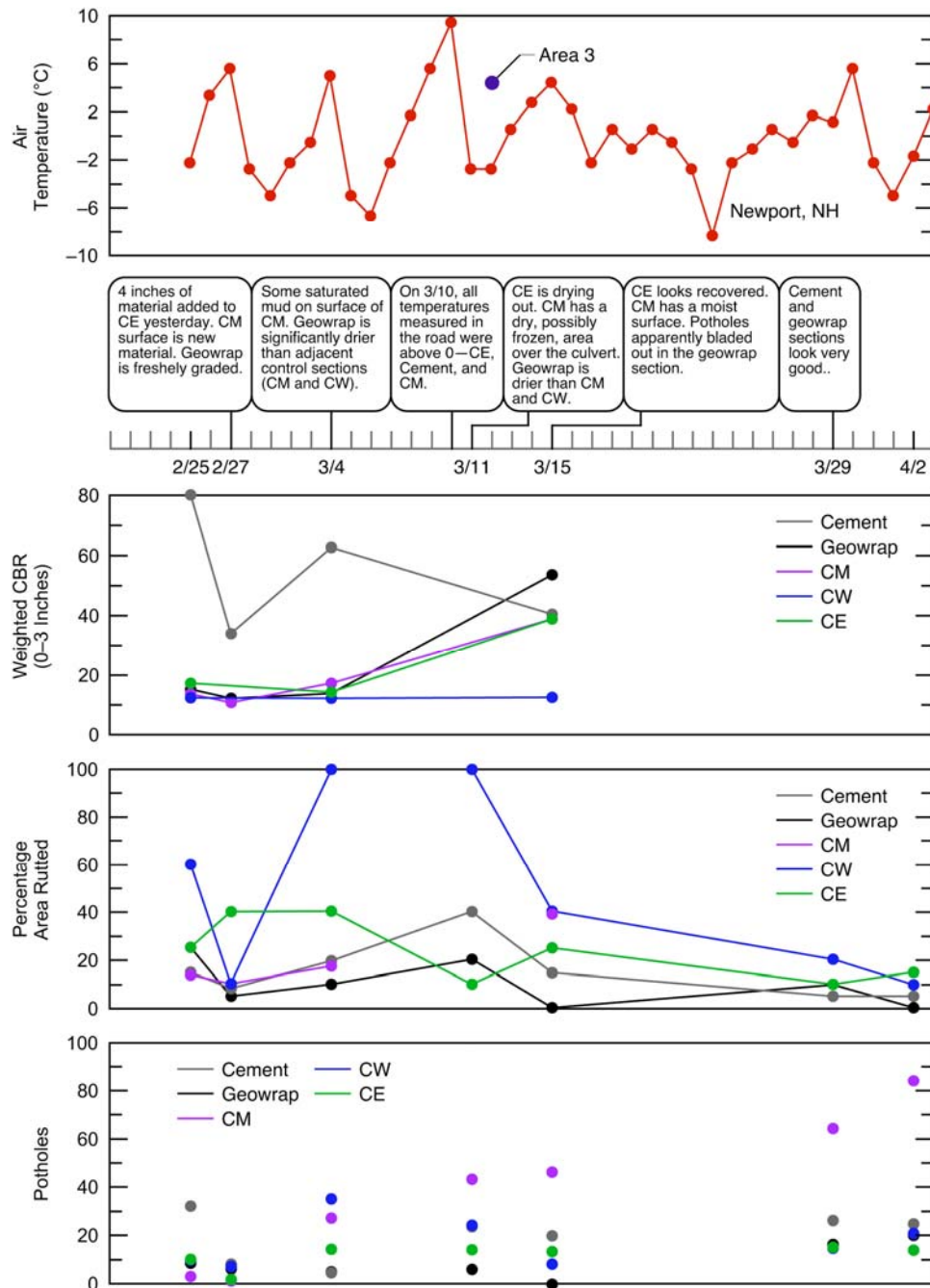


Figure 37. Air temperatures at Newport and datalogger enclosure temperature (top graph), annotated timeline, weighted CBR determinations for the top 3 in. of the road surface, percentage of the test section rutted, and number of potholes in the test sections for Area 3, 2002 mud season.

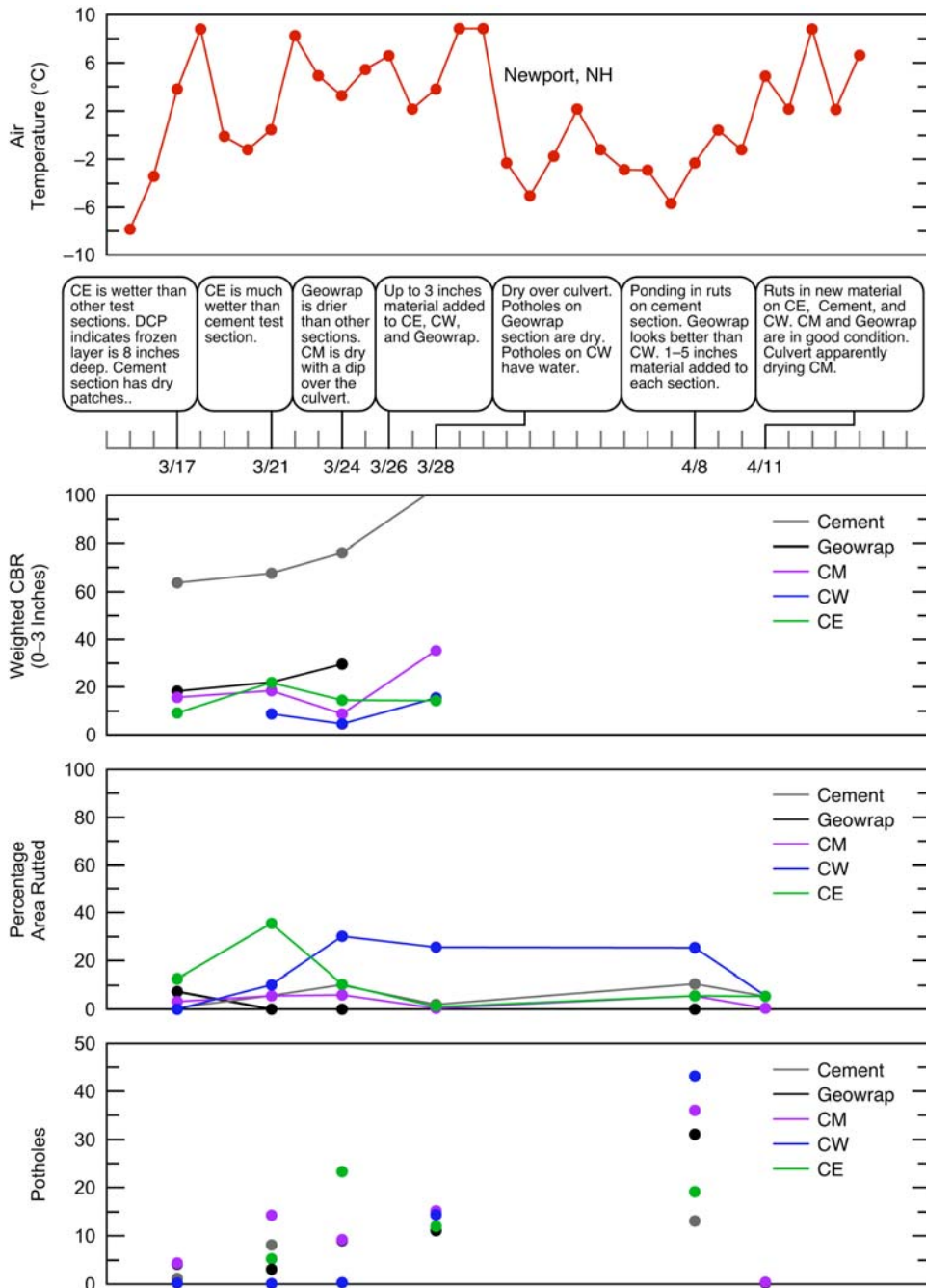


Figure 38. Air temperatures at Newport (top graph), annotated timeline, weighted CBR determinations for the top 3 in. of the road surface, percentage of the test section rutted, and number of potholes in the test sections for Area 3, 2003 mud season.



**Figure 39. CW (foreground) and Geowrap sections (background) on March 11, 2002. The CW ends and Geowrap section begins at the location where the soil transitions from wet to dry.**



**Figure 40. Cement section on March 17, 2003, showing drying compared to the CE (in the background).**

#### Area 4

We observed during site visits that thaw at the surface generally progressed upslope from the CW to the CE during both seasons; however, temperature data do not indicate this at 6-in. depths. The 2002 temperature data were inadequate to make such a determination, but 2003 temperatures measured at 6 in. indicate that the GCBD thawed soonest, which is probably related to relatively low moisture content compared to the other sections, as discussed below. The CW of Area 4 was at the bottom of a west-facing slope, near an intersection, and was subjected to considerably more sunlight than the adjacent test section, the GCBD (e.g., Fig. 41). In turn, the GCBD section was subjected to more sunlight than the CM, Separator section, and CE.

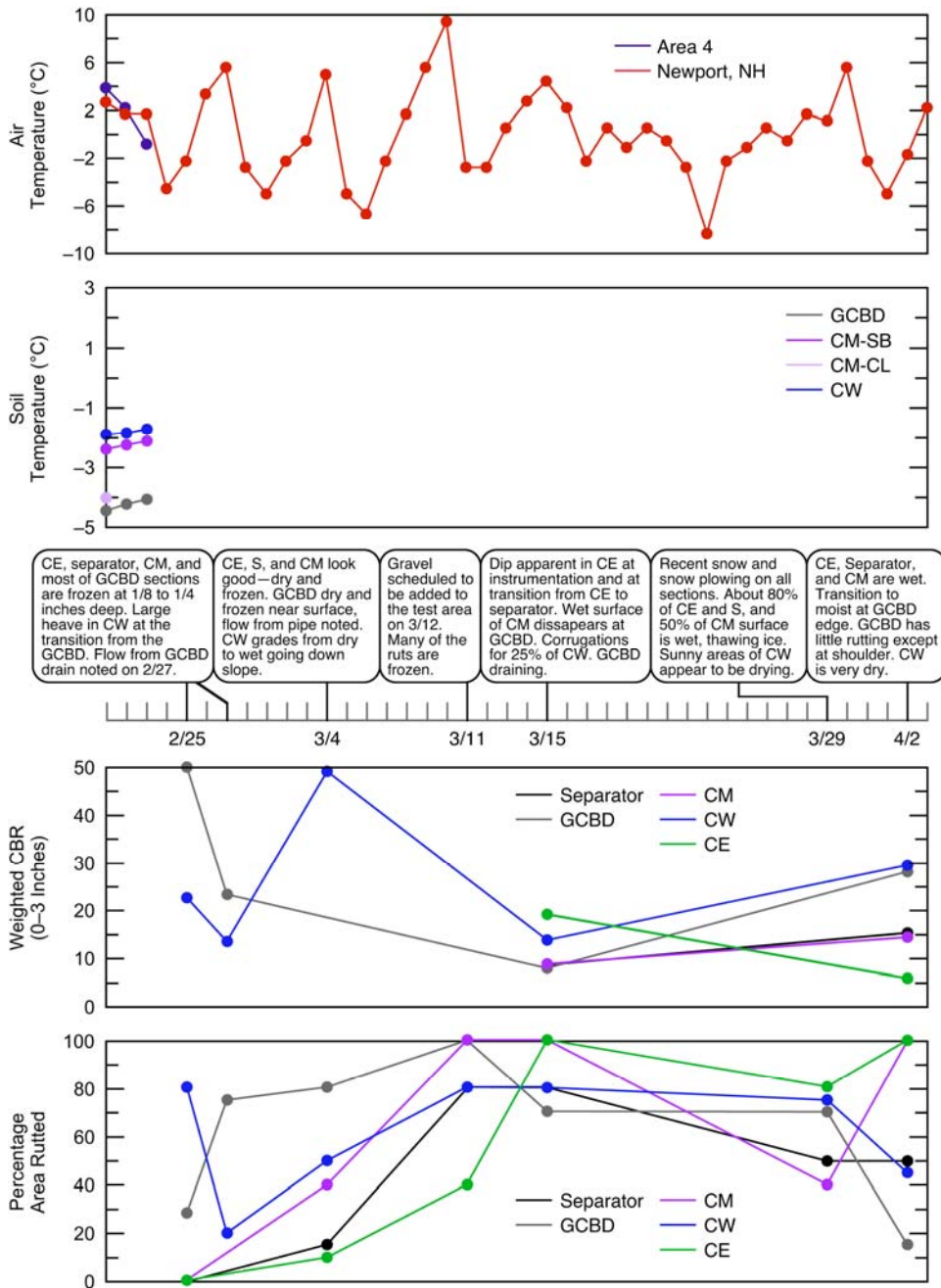
During both 2002 and 2003 in Area 4, the GCBD section gained strength more rapidly than the adjacent control sections, while the Separator section did not.



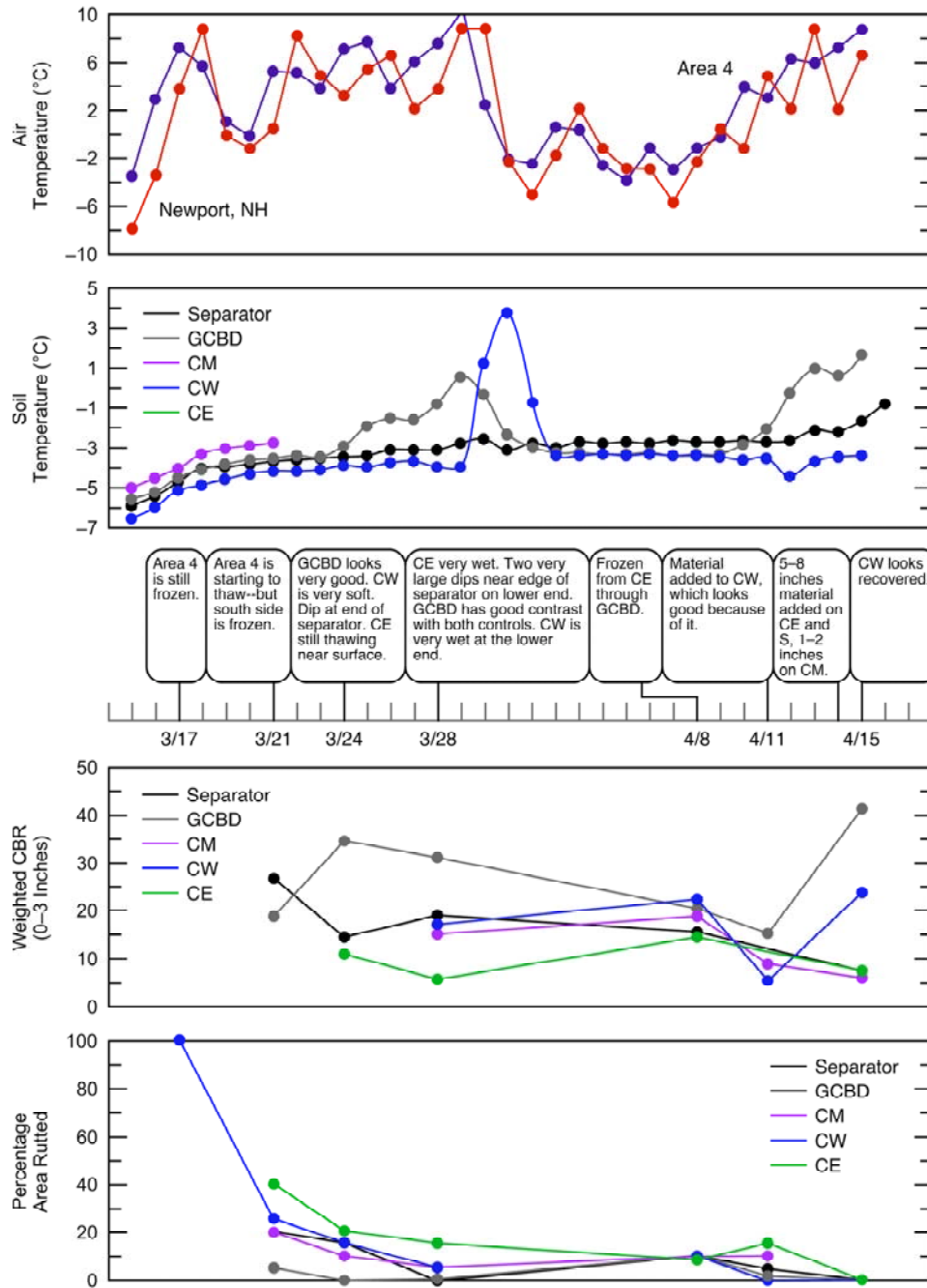
**Figure 41. CW of Area 4 on March 24, 2003, showing its sunny exposure. The orange cones mark the ends of the test section. Note that new material was added to this section. The GCBD section is in the foreground.**

Discounting the CBR values from February 25 and 27 because of the probability that they were influenced by frozen material, the CBR determinations from 2002 indicate that the GCBD section recovered strength more rapidly than both of the adjacent controls (CW and CM) from March 15 to April 2 (Fig. 42). During the same time the Separator section did not show an improvement over the CM; however, both the Separator section and the CM were stronger than the CE on April 2, 2002. Rutting in the test sections correlate well to CBR values on April 2, 2002.

During the 2003 thaw the GCBD section performed very well compared to the adjacent controls (Fig. 43). It had CBR values that were approximately equal to, or higher than CW and CM from March 24 to April 15, and there is again indication of more rapid recovery of strength than the CW and CM from April 11 to April 15. The Separator section did not demonstrate either improved values or more rapid recovery than the adjacent control sections during 2003.



**Figure 42. Air temperatures at Newport and datalogger enclosure temperature (top graph), temperature measurements in the soil at 6 in. depth, annotated timeline, weighted CBR determinations for the top 3 in. of the road surface, and percentage of the test section rutted for Area 4, 2002 mud season.**



**Figure 43. Air temperatures at Newport and datalogger enclosure temperature (top graph), temperature measurements in the soil at 6 in. depth, annotated timeline, weighted CBR determinations for the top 3 in. of the road surface, and percentage of the test section rutted for Area 4, 2003 mud season.**

## 6.5 Westford

In 2002, monitoring of test sections in Westford began on March 8, and the last day of monitoring was April 10. Additional days of monitoring were March 18, 15, and 30. The thaw season was characterized by the onset of thawing between March 8 and 15, the return of low temperatures and refreezing until thawing returned around March 30, and then rapid thawing continuing until April 10, at which time the road surface had recovered to serviceable levels.

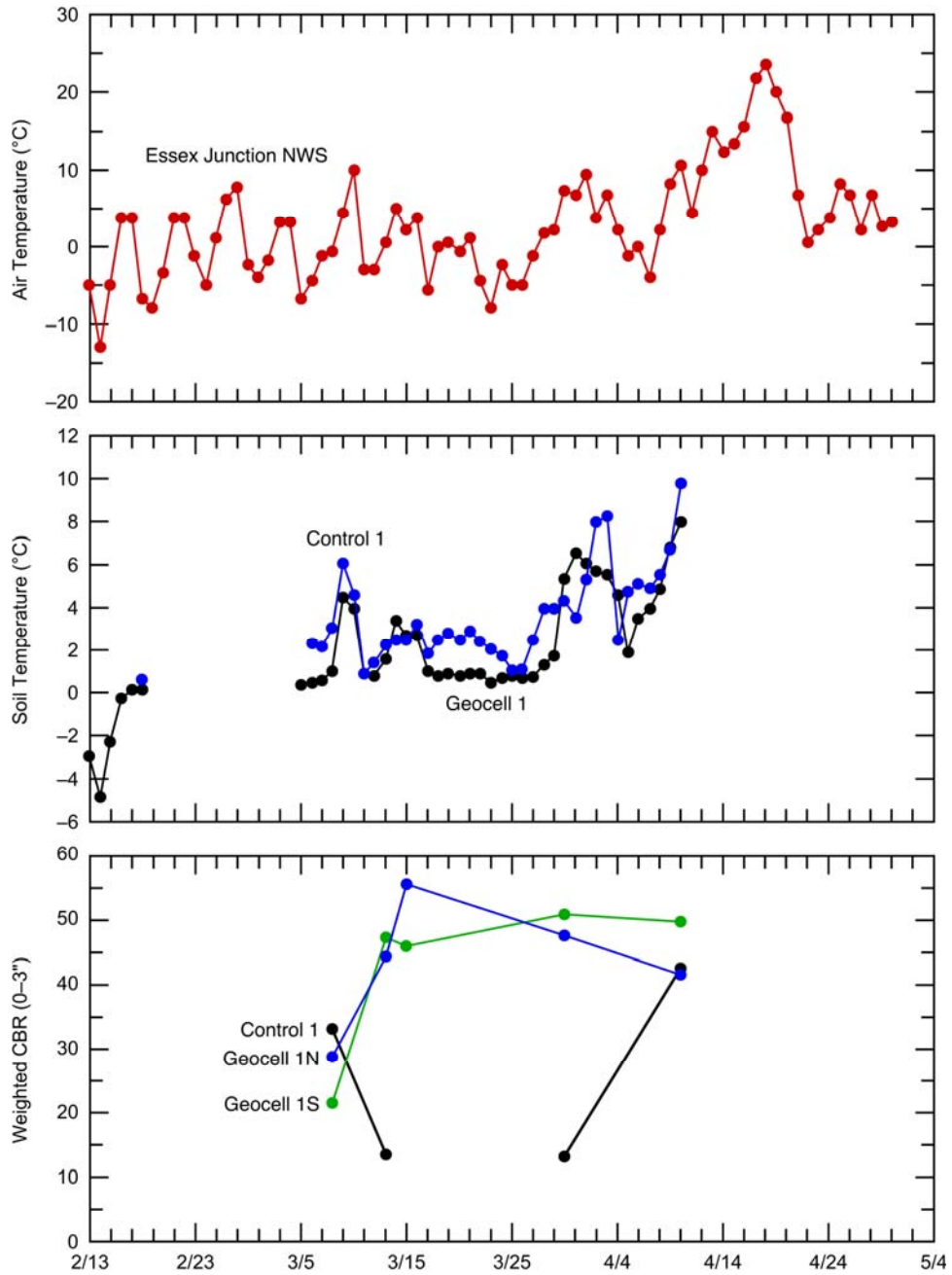
The 2003 test season monitoring began on March 17 and concluded on April 25. There were a total of ten days of monitoring on the dates of March 17, 19, 21, 26, 28 and April 2, 8, 10, 15, and 25. Average air temperatures climbed above freezing on March 17, remained above freezing until March 31, hovered around freezing until April 10, and then began to warm again throughout April. The soil temperatures showed a similar behavior. Some soil temperature data were lost in April, since the memory capacity of the datalogger was exceeded and later data overwrote earlier data. Soil temperatures at the shallow depth of 6 in. closely tracked the air temperature.

In 2002, there were not enough soil temperature data to determine an order of thaw of the test sections. (The Geocell 2 and Drain sections did not have enough data to make such estimates.) The temperatures collected for the Geocell 1 section indicate that it was warmer and thawed sooner than other test sections monitored in 2002 for which data are available. The Control 1, Control 3, and Grid section data indicate thawed conditions on March 5, but there were no data for days immediately preceding this date. The Cement section had thawed temperatures on March 7.

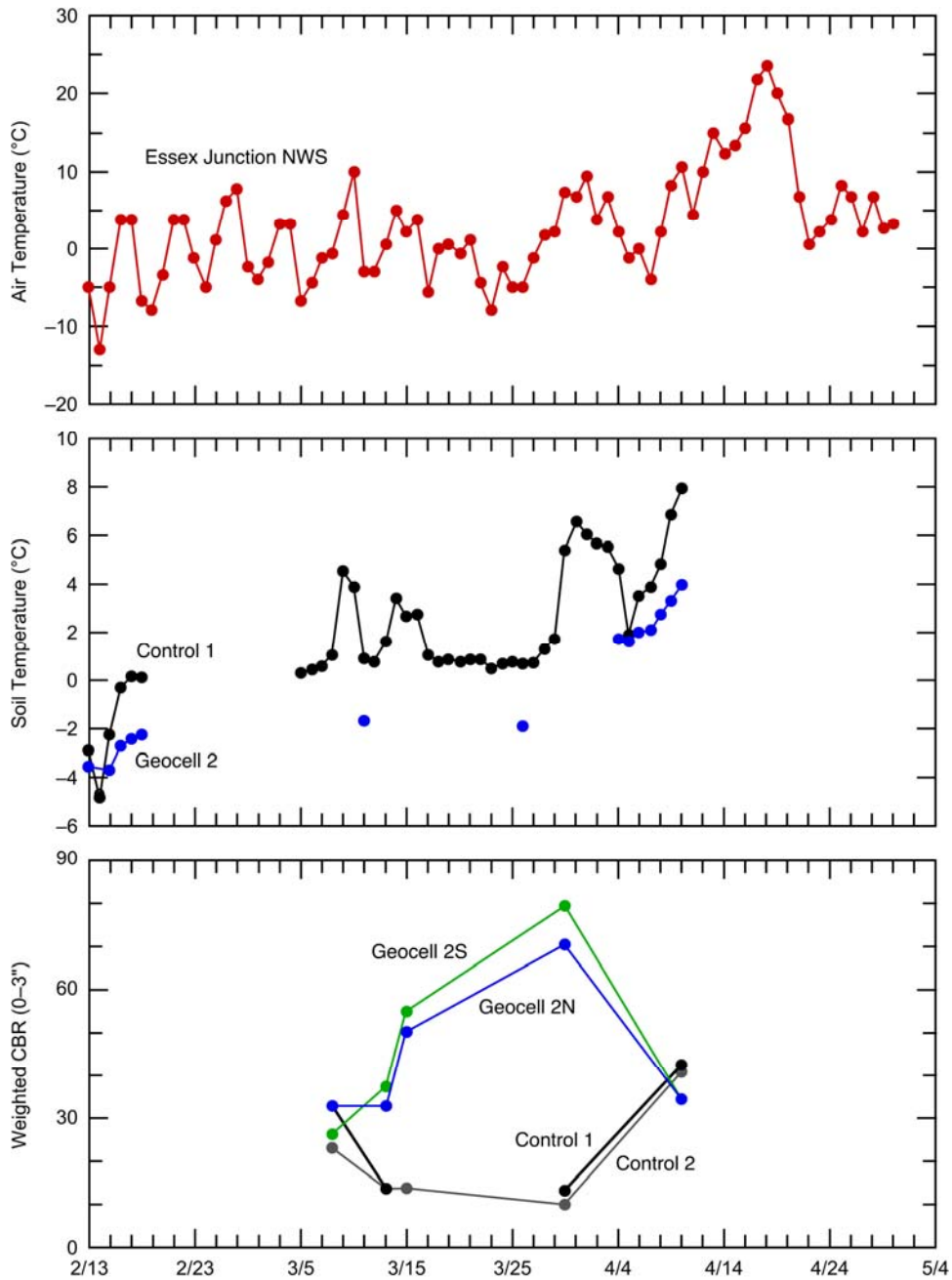
In 2003, the Cement appeared to thaw the soonest, with above-freezing temperatures recorded on the shallowest thermocouple on March 9. The Control 3 section had thawed temperatures recorded on March 16, followed by the Drain and Control 1 sections on March 17. The Grid had thawed temperatures on March 18, while the Geocell 1 and 2 sections indicate thawed temperatures on March 21 and 22, respectively.

### *Cellular confinement system test sections*

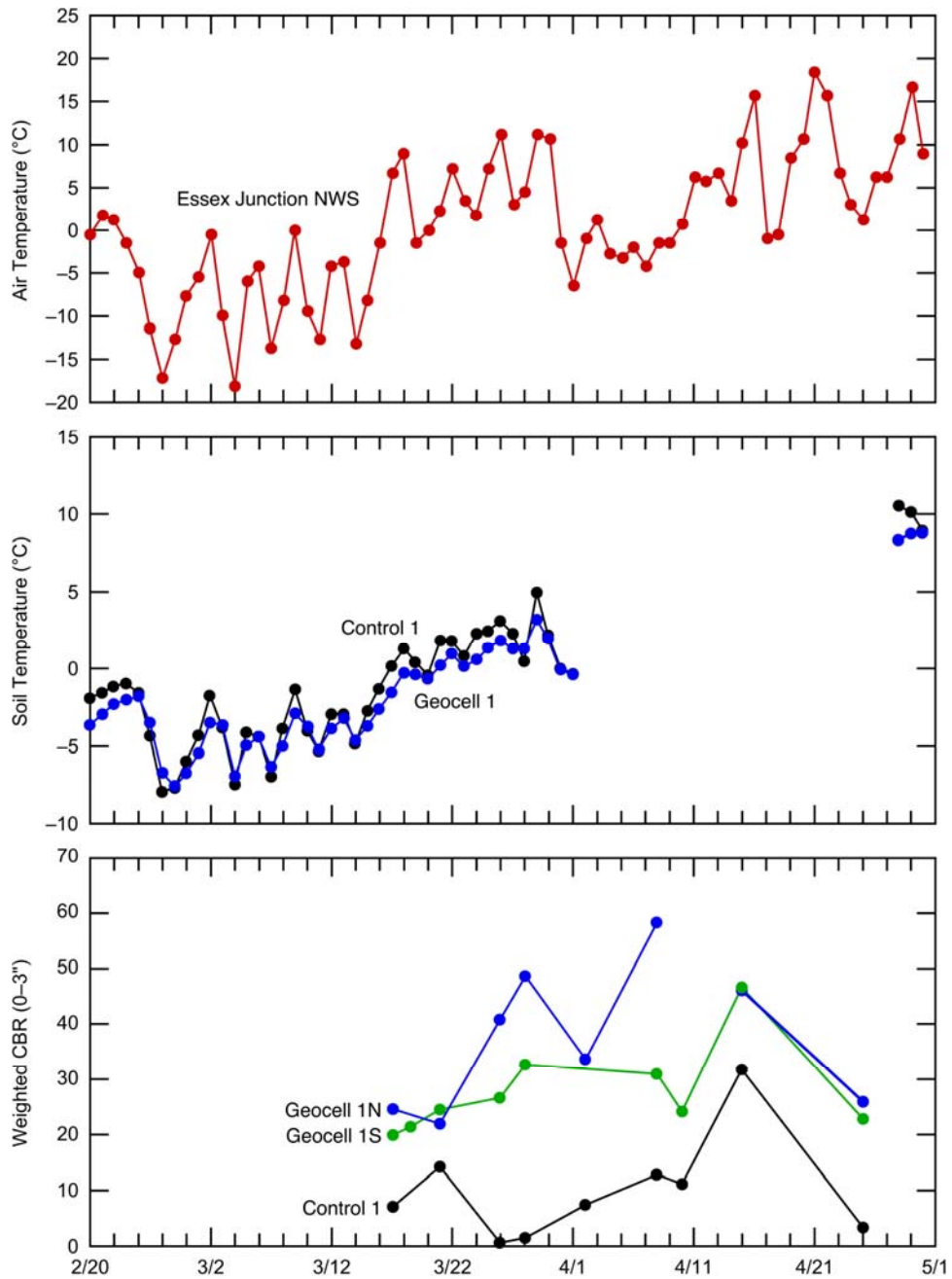
Geocell 1 and 2 test sections performed very well during thaw (Fig. 44–47). Soil temperature plots show the early thaw and then a period where soil temperatures hovered around freezing in 2002. The test sections showed very little surface distress in the form of rutting or potholes. Observed rutting was never more than 1 in. deep, and the affected area was typically less than 10% of the test section. Potholes were usually smaller than 6 in. in diameter and less than 1 in.



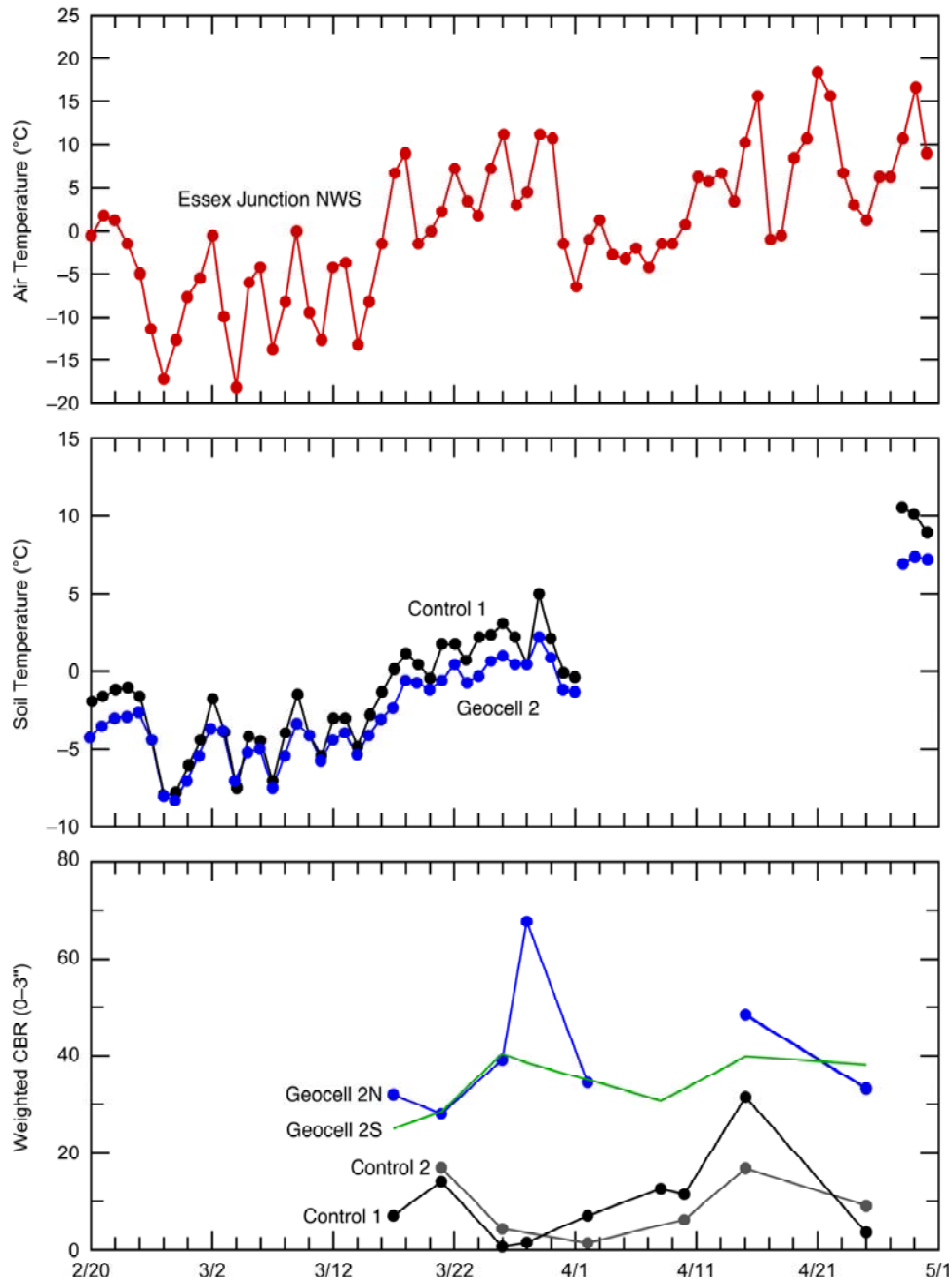
**Figure 44. Air temperatures at Essex Junction, temperature measurements in the soil at 6 in. depth, and weighted CBR determination for the top 3 in. of the road surface for the Geocell 1 test section, 2002 mud season. Geocell 1 N and 1 S readings were taken approximately 25 ft from the north and south edges of the test section, respectively.**



**Figure 45. Air temperatures at Essex Junction, temperature measurements in the soil at 6 in. depth, and weighted CBR determination for the top 3 in. of the road surface for the Geocell 2 test section, 2002 mud season. Geocell 2 N and 2 S readings were taken approximately 25 ft from the north and south edges of the test section, respectively.**



**Figure 46. Air temperatures at Essex Junction, temperature measurements in the soil at 6 in. depth, and weighted CBR determination for the top 3 in. of the road surface for the Geocell 1 test section, 2003 mud season. Geocell 1 N and 1 S readings were taken approximately 25 ft from the north and south edges of the test section, respectively.**



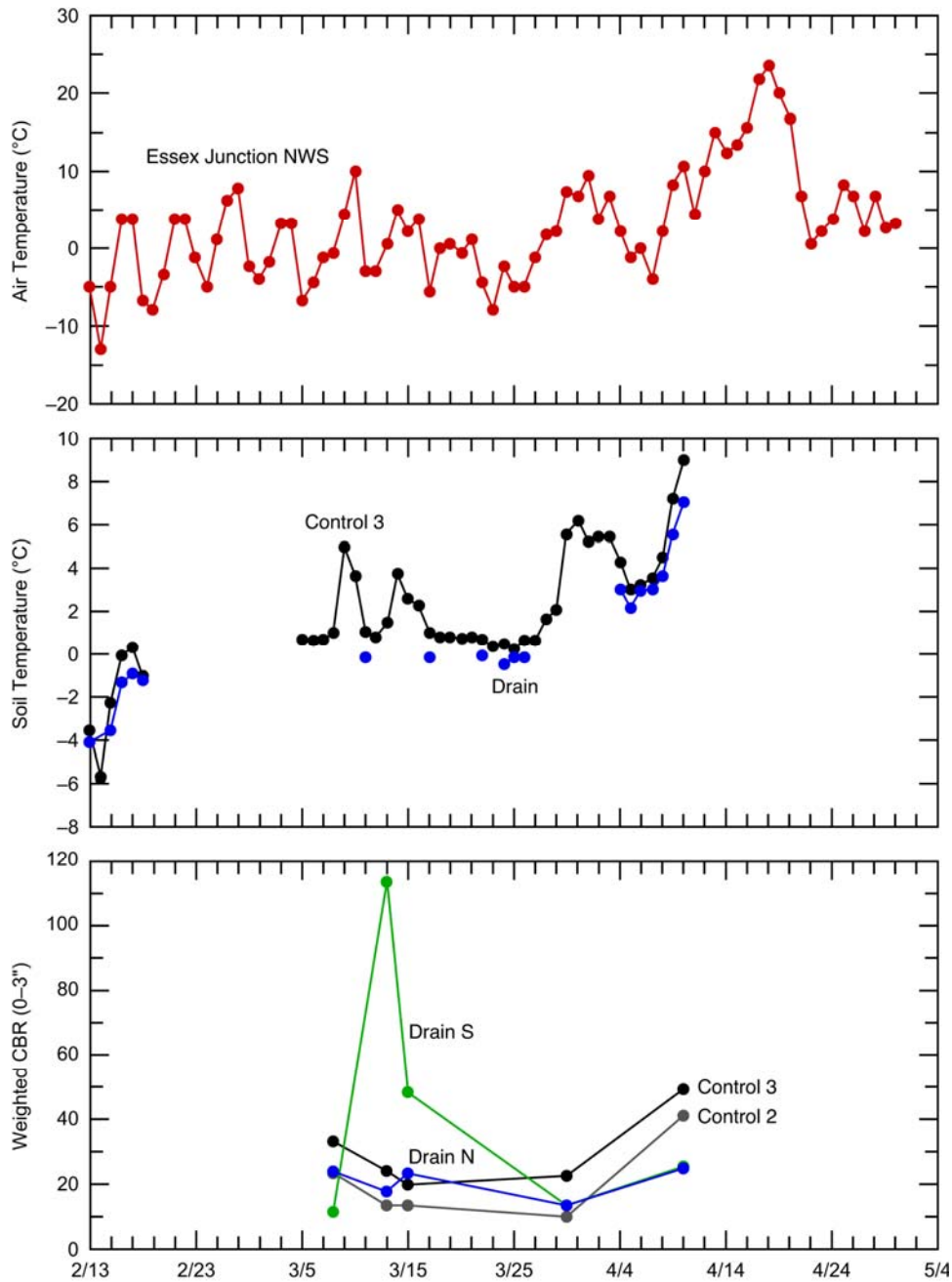
**Figure 47. Air temperatures at Essex Junction, temperature measurements in the soil at 6 in. depth, and weighted CBR determination for the top 3 in. of the road surface for the Geocell 2 test section, 2003 mud season. Geocell 2 N and 2 S readings were taken approximately 25 ft from the north and south edges of the test section, respectively.**

deep. In 2002, the number of potholes counted ranged from 7 to 12, while in 2003 the number ranged from 0 to 6. Adjacent control sections typically contained 10 or more 3-in.-deep potholes, and rutting or pumping distress existed over 20% of their area.

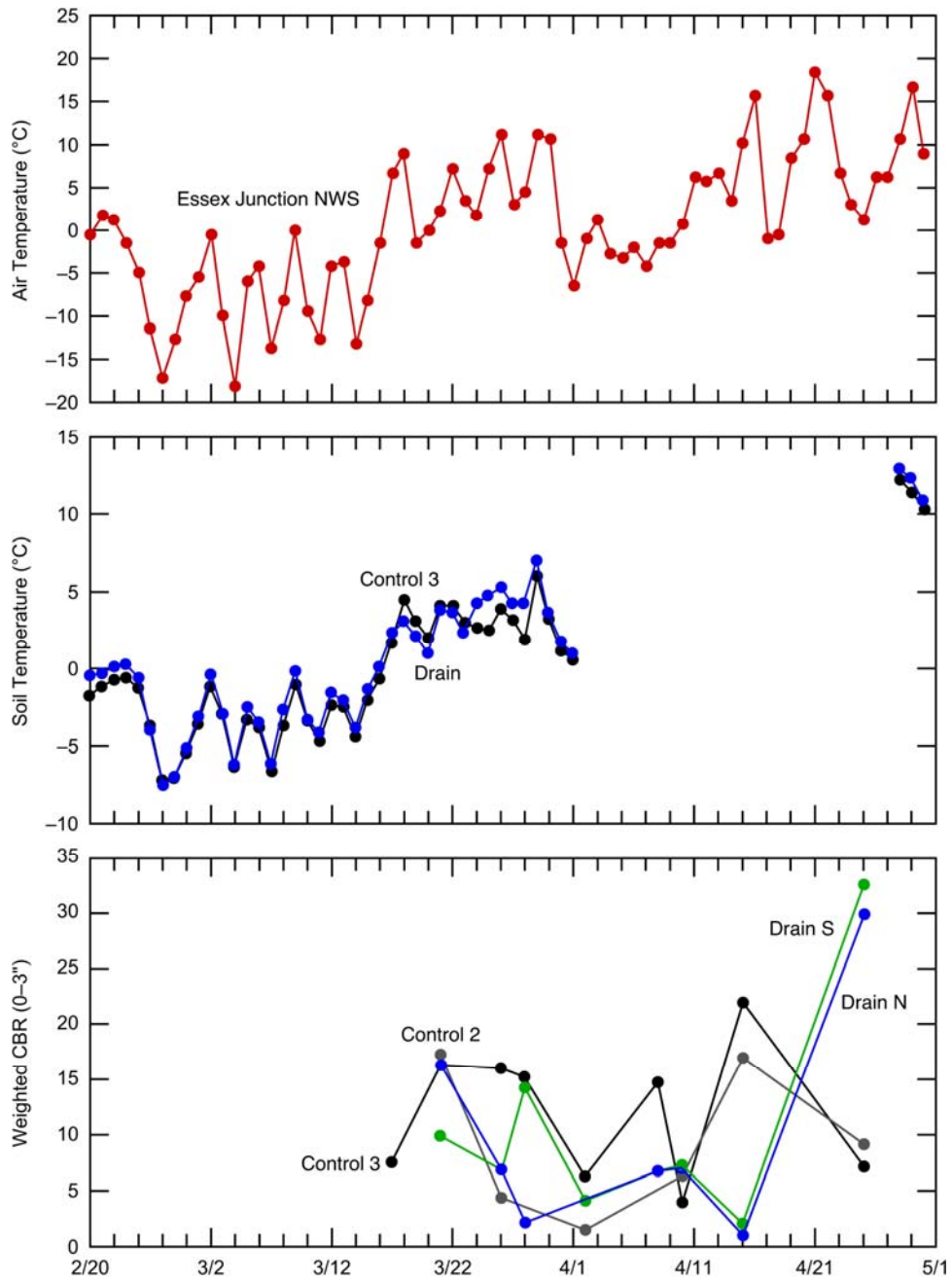
Strength measurements, plotted as the weighted CBR value in the upper 3 in. of the road surface, indicate very high values relative to the control sections during the period of observation in 2002. With the onset of thaw, the CBR values for the control sections dropped to approximately 10%, while the cellular confinement system test sections typically remained at 40% or more. In 2003, the CBR strength values were generally above 30%, while the control section CBR values were around 10%. As in 2002 there was negligible visual performance degradation in either Geocell 1 or 2 in 2003.

#### *Drain test section*

The Drain test section showed only slightly better performance than the adjacent control sections in 2002 (Fig. 48). On two of the monitored days, March 13 and 15, the south end of the Drain test section had higher values than the control sections. Otherwise, the strength readings were similar for the Drain and control sections. This could be because of the relatively mild winter in this year with less frozen water accumulated in the road and because the drain is lower relative to the road surface at the south end of the test section. In the following severe winter and thaw season of 2003, however, this effect was not observed. In 2002, the CBR values for the Drain test section were in the range of 10–20% during thawing and recovered to 20% to over 40% at the end of monitoring (Fig. 48). In 2003, the CBR values for the Drain test section were in the range of 10–20% during thaw and recovered to over 30% at the end of monitoring (Fig. 49).



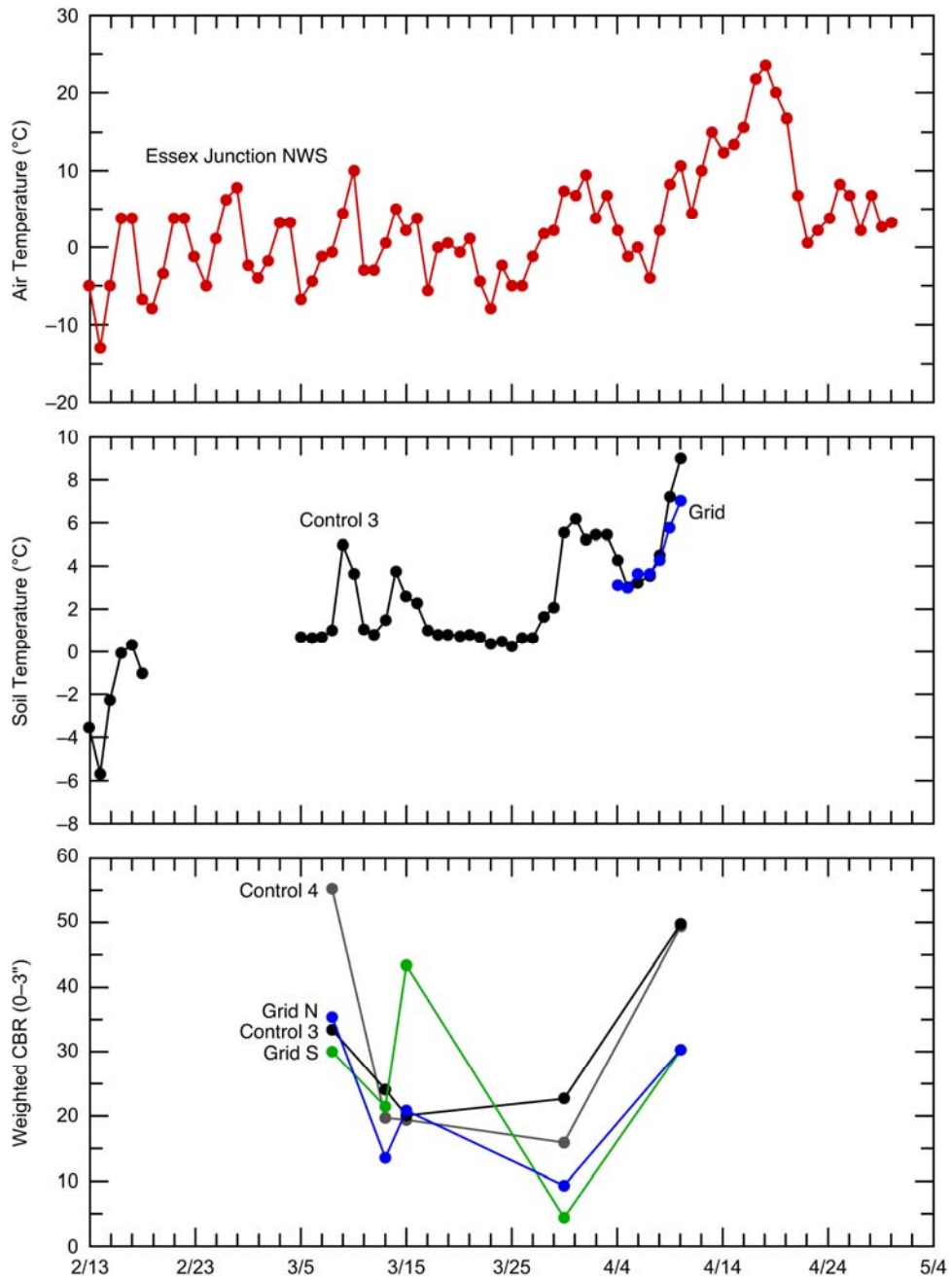
**Figure 48. Air temperatures at Essex Junction, temperature measurements in the soil at 6 in. depth, and weighted CBR determination for the top 3 in. of the road surface for the Drain test section, 2002 mud season. Drain N and S readings were taken approximately 25 ft from the north and south edges of the test section, respectively.**



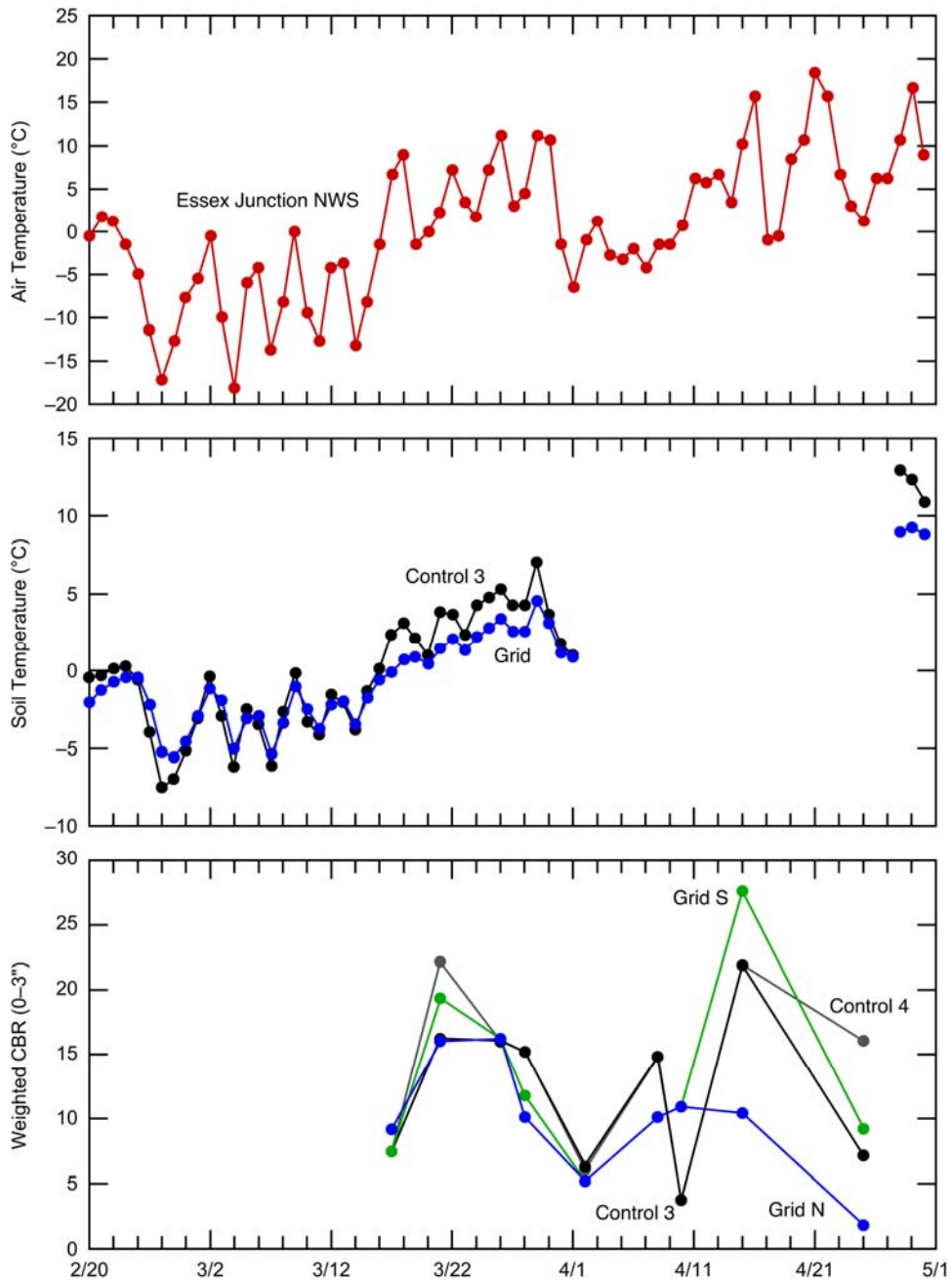
**Figure 49. Air temperatures at Essex Junction, temperature measurements in the soil at 6 in. depth, and weighted CBR determination for the top 3 in. of the road surface for the Drain test section, 2003 mud season. Drain N and S readings were taken approximately 25 ft from the north and south edges of the test section, respectively.**

*Geogrid test section*

The Geogrid test section results indicate similar performance of the test section and adjacent control sections (Fig. 50 and 51). In 2002, the CBR strength measurements dropped to around 20% at the onset of thaw and remained between 5% and 20% until recovery to 30% or more at the end of monitoring. In 2003, the strength measurements of CBR were very similar to those of the adjacent control sections, and rutting was significant during the majority of the monitoring period. Rut depths were typically 3–4 in. and affected almost the full length of the test section on both of the travel lanes. There were as many as 33 individual potholes. These surface distresses aided in holding excess water on the road surface. CBR values ranged between 5% and 15% for the majority of the measurements made.



**Figure 50. Air temperatures at Essex Junction, temperature measurements in the soil at 6 in. depth, and weighted CBR determination for the top 3 in. of the road surface for the Grid test section, 2002 mud season. Grid N and S readings were taken approximately 25 ft from the north and south edges of the test section, respectively.**

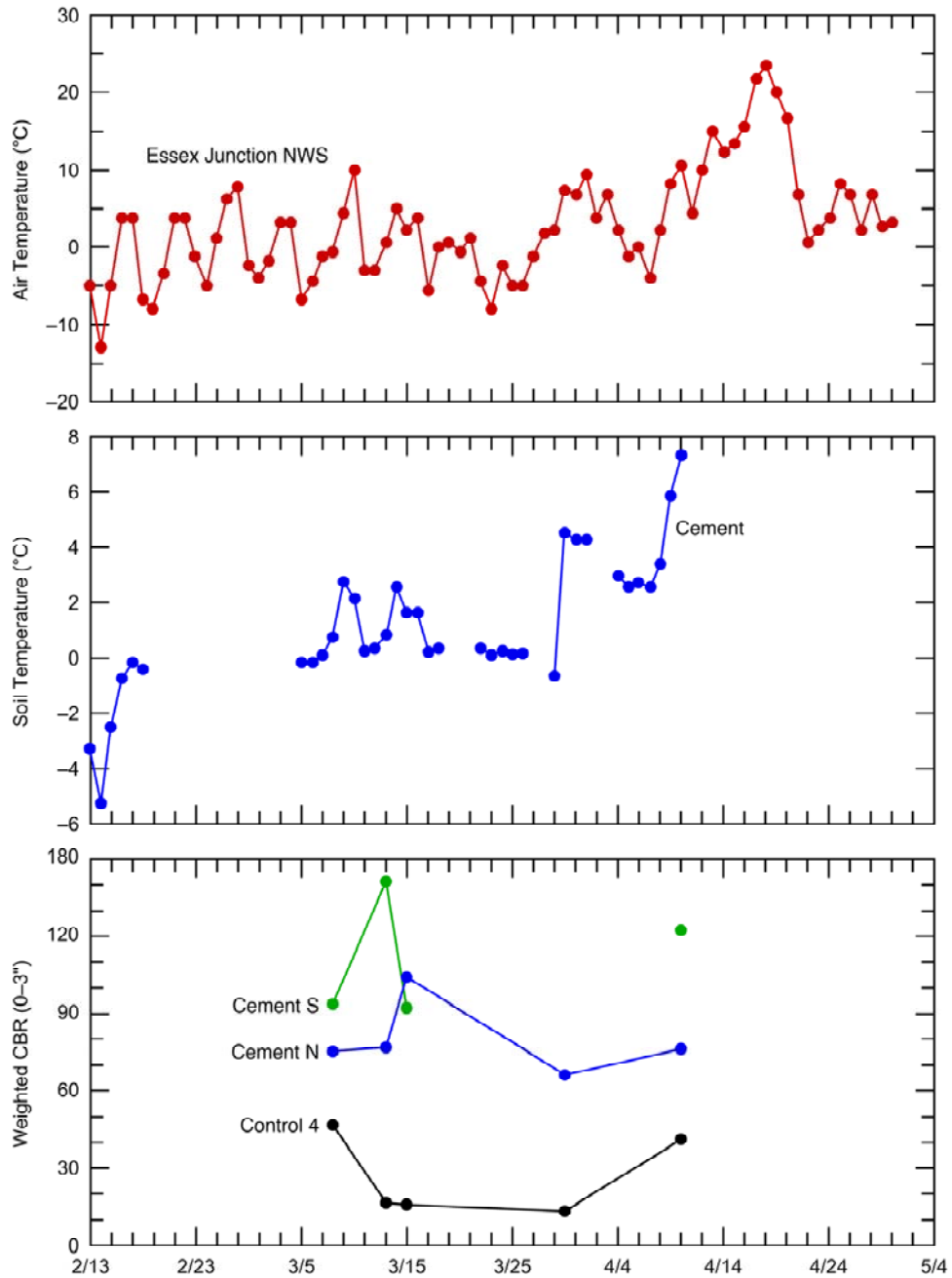


**Figure 51. Air temperatures at Essex Junction, temperature measurements in the soil at 6 in. depth, and weighted CBR determination for the top 3 in. of the road surface for the Grid test section, 2003 mud season. Grid N and S readings were taken approximately 25 ft from the north and south edges of the test section, respectively.**

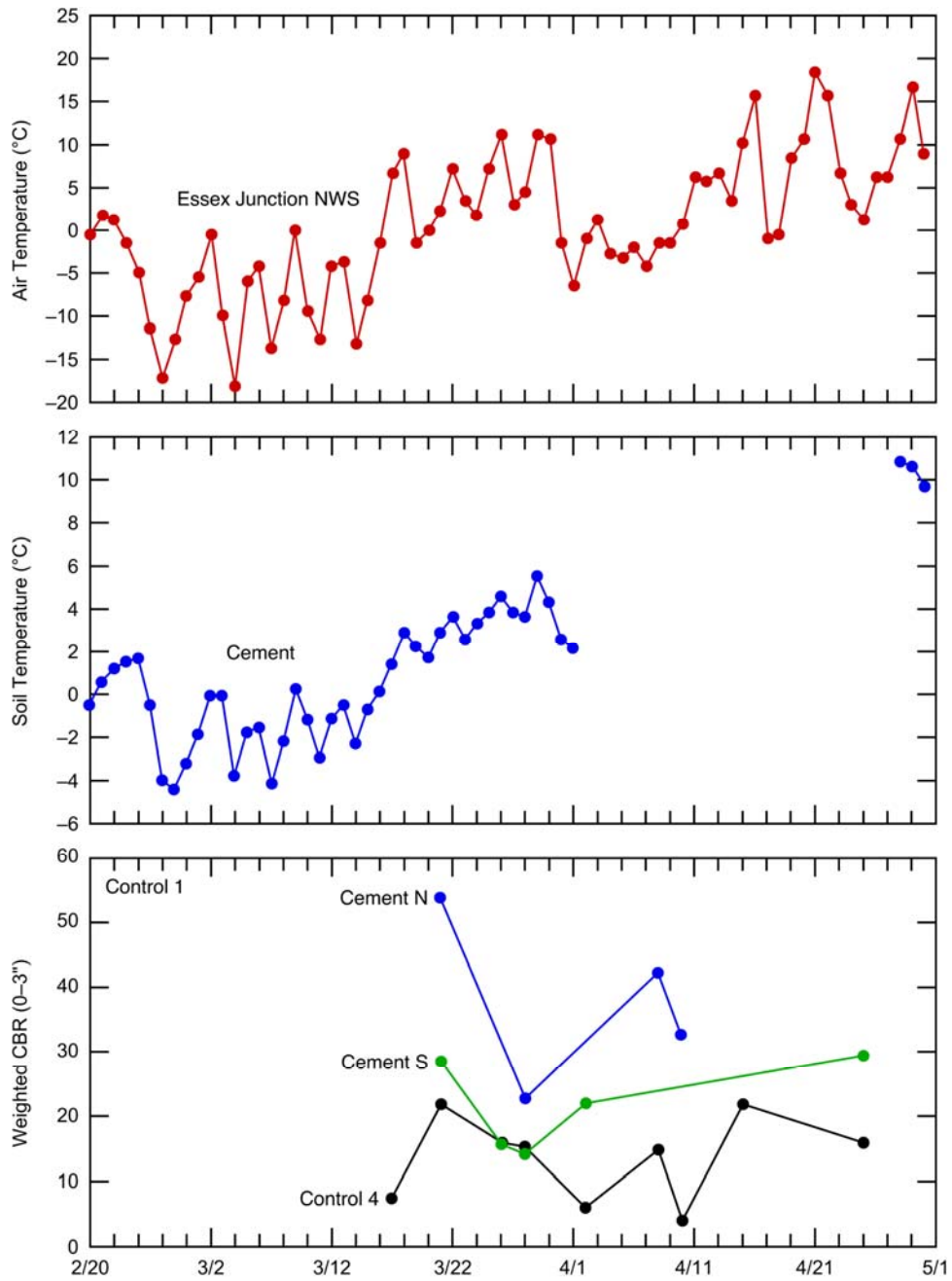
*Cement test section*

The Cement test section performed extremely well during the first season of observation. Test results (Fig. 52) indicate superior strength characteristics throughout the measurement period. CBR values were consistently above 80% and often presented a challenge for the DCP operator to penetrate the cement stabilized layer. The only visual sign of distress was an occasional small pothole (less than 6 in. in diameter and less than 2 in. deep). There was never any rutting of the surface or softening noticed in this section.

The Cement test section also performed very well during 2003 (Fig. 53). However, the CBR values appear to be lower than those from the previous year. This is because of a change in the geometry of the section, since the town road official had to add 4 in. of gravel over the cement-stabilized section during the summer of 2002. This was in response to a complaint from neighbors that the road surface was “dusting” under traffic. So the weighted CBR measurements in the top 3 in. now reflect an unbound material in comparison to the previous year. The weighted CBRs from 3 to 6 in. in depth were much higher and reflected the same superior performance of the Cement test section noted in the previous year of observations.



**Figure 52. Air temperatures at Essex Junction, temperature measurements in the soil at 6 in. depth, and weighted CBR determination for the top 3 in. of the road surface for the Cement test section, 2002 mud season. Cement N and S readings were taken approximately 25 ft from the north and south edges of the test section, respectively.**



**Figure 53. Air temperatures at Essex Junction, temperature measurements in the soil at 6 in. depth, and weighted CBR determination for the top 3 in. of the road surface for the Cement test section, 2003 mud season. Cement N and S readings were taken approximately 25 ft from the north and south edges of the test section, respectively.**

## 7 DISCUSSION

In this project, only methods that either permanently increased the strength of the upper 12 in. of the road surface or decreased the water content of the road bed resulted in significant performance improvement during the spring thaw period.

The cement and the cellular confinement systems (geocells) improved the strength of the road surface and upper layers of the road year-round, and they were significantly stronger than adjacent control sections during mud season. The weighted CBR values in the top 3 in. were greater than or equal to 30 at all times for cement-treated soil. Similarly, the Geocell test sections had weighted CBR values greater than or equal to 20, while the control section values ranged from 1 to 15 during spring thaw.

The improved performance of the Geowrap and GCBD sections is due to a drier soil layer, on average, above the materials installed. The sooner a section thawed, the more quickly it recovered. Thus, even though the initial weakening in the upper few inches of the road was similar to the control sections (although usually somewhat stronger), strength recovery was more rapid because less water froze and therefore less thawing was required and less water became available during thaw.

Geogrids and geotextile separators provided no observable benefit to the roads during mud season. Geogrid and geotextile are typically placed on weak soil and covered with high-quality aggregate to improve the bearing capacity of the underlying weak soil. Design guidance is based on this concept. However, in this application the critical weakened soil condition occurs in the top 3–12 in. of the road surface. Thus, only improvements that affected this portion of the road bed, resulted in measurable improvement.

The drainage test sections showed no significant improvement compared to the adjacent controls in the two seasons monitored, with the possible exception of Westford in 2003. Apparently, the saturated soil of the top 3–12 in. of the road cannot drain laterally rapidly enough for the drains to have a significant impact on performance.

The soil temperature data and observations from Windsor Areas 1 and 2 for both thaw seasons suggest that the construction disturbance led to drier and perhaps less dense soil above the Grid and Separator sections, especially in 2002. Temperature records indicate a more rapid response to changes in air temperatures above the Separator and Grid sections, sections in which the surface layers had been removed and recompacted just prior to the winter of 2001-02. In addition, the Grid section did not perform as well as the control sections during thaw

of 2002, but the reverse was true during the thaw of 2003. This suggests that the surface soil was less dense than the adjacent controls during 2002.

Although the Grid and Separators did not apparently improve the road surface conditions during spring thaw, there may be a benefit related to their use that we could not observe. It may be that less material is required to “stabilize” these sections over time (e.g., several years) because of the reinforcement functions of these materials. However, the period of observation was too short to make such a determination. Similarly, the drains as installed may provide some benefit by diverting surface runoff.

While four techniques significantly improved road performance during the thaw season compared to adjacent control sections, we will not rank them relative to each other. These techniques were not compared to each other under identical subgrade and thaw degradation conditions. Furthermore, the effectiveness of a technique may vary with factors such as depth to water, slope, and severity of the freezing and/or thaw degradation. In addition, we monitored for only two seasons, so there is not enough information to judge the performance of each technique over time.

## 8 COSTS

### 8.1 Construction

For most of the geosynthetics, material costs were a large portion of total costs. The geogrids cost about \$1.60 and \$2.80 per square yard. The cellular confinement products cost \$4.50 per square yard for 4-in.-high cells and \$6.75 per square yard for 6-in.-high cells. Cement in bags (purchased in large quantities) is approximately \$7.15 per bag. If bulk deliveries could be used, this price could drop to around \$5.50 per bag. Each of the 100-ft test sections in Westford took about one day to complete with three workers, one loader, and one dump truck for equipment. The Westford cement section also required the rental of a Bomag tiller to mix the cement with the scarified surface of the road. Scarifying was accomplished in the Windsor section using a grader with a scarifying rake attachment.

During July, August, and September 2003, another section of Old Stage Road, just south of the test sections in Westford, was rebuilt. This rebuild was done in a more conventional manner, beginning on the existing road surface. The construction started with the placement of a geotextile layer over the road surface, then placement of 1 ft of crushed stone, and capping with 1 ft of road gravel. Some additional ditch work was required to improve drainage adjacent to the road. The length of this rebuilt section was approximately 0.9 miles, and the total cost was approximately \$98,000 (\$110,000 per mile, or about \$21 per linear foot). This cost can be compared to the estimated costs listed below for each of the test sections extrapolated to a one-mile production section of rebuild. The Westford Road Commissioner stated that if he were to implement the use of the test section methodologies on larger-scale projects, he would build up from the existing surface and not pre-excavate as was done in the shorter test sections.

**Table 9. Estimated costs for various section types.**

Section type	Estimated cost/mile
4-in. geocells	\$143,000
6-in. geocells	\$175,000
Soil-cement stabilization*	\$141,000
Geowrap*	\$127,000
Patented GCBD*	\$250,000–444,000

\* These costs are based on the costs of the contractor. Savings may be realized by use of town crews.

The costs shown in Table 9 reflect a premium ranging from 15 to 400% relative to rebuilding with stone, gravel, and geotextile. Also, there are geometric differences between the choices. The gravel rebuild raises the road by 2 ft, whereas the cellular confinement systems raise the road by 1 ft and the soil cement option raises the road by 4 in. The GCBD is expensive and not yet fully estimable because there is not (yet) a manufacturer producing the transport layer in large quantities.

## 8.2 Maintenance

The geocells required negligible maintenance during spring thaw. Similarly, the Geowrap, Cement (once covered with gravel), and GCBD sections required significantly less maintenance during spring thaw than adjacent control sections. We estimated that these three types of sections required at least 50% less maintenance during spring thaw. Because of variations in wages and the costs of gravel, crushed stone, and available equipment, the cost and benefits of implementing these techniques will vary. Decreased wear and tear on vehicles should also be considered in deciding whether to implement each technique.

The Town of Windsor reported that they spend between \$2000 and \$6000 annually (in 2004 dollars) on emergency repairs during spring thaw. These costs are for town labor and equipment to haul material and grade the road surfaces. The Hunt Hill Road portion corresponds to a third of this budget. For an estimated treatment length of 600 ft on Hunt Hill, this corresponds to \$1–3 per linear foot per year, excluding the costs of town-supplied gravel. Assuming 200 cubic yards at \$5 per cubic yard for material costs, approximately \$100 per average year for material purchased at a borrow pit in town (i.e., a relatively short haul distance) should be added. These repair costs exclude increased travel time costs for the maintenance equipment. Implementing the least expensive technique, the geowrap, at approximately \$24 per linear foot initially seems prohibitive. However, using the town road crew to construct this relatively simple technique would probably cost considerably less.

## 9 SUMMARY AND CONCLUSIONS

### 9.1 Performance of mud season remedies

A summary of each technique and its performance is provided in Table 10.

**Table 10. Mud season remedies and summary of results.**

Remedy	Description	Site	Performance
Geogrid	Geogrid placed 12 in. below the road surface	Westford and Windsor	No observable improvement
Separator	Separator placed 12 in. below the road surface	Windsor (two installations)	No observable improvement
Cellular confinement system	Geocells placed 12–14 in. below the road surface and sandwiched between geotextile separators; one section used 6-in.-thick cells, and the other used 4-in.-thick cells	Westford (4-in.- and 6-in.-thick cells)	Significant improvement. Weighted CBR values in top 3 in. were $\geq 20$ compared to control section values ranging from 1 to 15 during spring thaw. Both thicknesses worked well—4 in. and 6 in.
Drainage	Improved drainage at the edge of the roadway, using a trench drain a few feet lower than the road surface and parallel to the edge, constructed of crushed stone around a 4-in.-diameter perforated PVC drain, all wrapped in geotextile	Westford and Windsor	No observable improvement
Geosynthetic Capillary Barrier Drain (GCBD)	Patented GCBD placed 12 in. below road surface, sloped to one side and tied to a drain under the shoulder	Windsor (one installation)	Significant improvement. Primary benefit is accelerated recovery compared to adjacent controls. During thaw, the CBR values were equal to or higher than adjacent controls.
"Geowrap"	An encapsulated, free-draining, sand layer, wrapped in geotextile to provide strength and maintain materials separation	Windsor (one installation)	Significant improvement. Primary benefit is accelerated recovery compared to adjacent controls. During thaw, the CBR values were approximately equal to or higher than adjacent controls.
Cement	Portland cement to 6% by weight added to the native road surface material to create a stabilized surface course. In Windsor the cement was added to a 12-in. thickness. In Westford, the cement was added to an 8-in. thickness at a slightly higher percentage—about 8% by weight.	Westford and Windsor	Significant improvement. Weighted CBR values in top 3 in. of cement-treated soil were $\geq 30$ during spring thaw. Requires some attention to prevent dust formation during summer and maintenance problems during spring thaw.

Only methods that either permanently improved the strength of the top layers or decreased the water content of the road resulted in significant performance improvement during spring thaw. The cement and cellular confinement systems worked well by improving the strength of the upper layers of the soil, and the geowrap and GCBD provided benefit by keeping the upper layers of the soil relatively dry. Geogrid and geotextile separators provided no observable benefit to the roads during mud season.

The drainage sections provided no significant benefit. Apparently, the saturated soil of the top 3–12 in. of the road cannot drain laterally rapidly enough for the drains to have a significant impact on performance.

For cement stabilization, the cement-treated soil should be covered with at least 4 in. of material to prevent dust formation and to avoid maintenance problems related to blading.

The relative construction costs of the techniques, from least to most, are geowrap, cement, and cellular confinement. The cost of the Geosynthetic Capillary Barrier Drain cannot yet be estimated, as it is not manufactured. The geowrap is relatively easy to construct. All of these techniques result in maintenance savings.

## **9.2 Other observations and recommendations related to spring thaw road maintenance**

Road construction is accomplished much more quickly and effectively when the road is closed. Keeping one lane open at all times on relatively narrow roads led to troublesome windrows and installation of products with wrinkles that were too challenging to remove.

During spring thaw conditions, adding more surface material sometimes worsens the condition of the surface—resulting in more mud, ruts and heave in between the ruts. This technique should be applied with caution and possibly avoided if the saturation of the surface portion of the road is exceptionally high.

## **9.3 Recommendation for future research**

The temperature records we collected contain significant gaps for two reasons. One reason was miscommunication between the team members responsible for data management and those monitoring in the field. At other times, the central datalogger at a site failed, and the problem was not discovered until the next scheduled data download. Our experience with incomplete data recovery on this project has led us to recommend that all responsibility for data collection be held by one organization or participant. In addition, data should be downloaded from

dataloggers at much more frequent intervals than the datalogger memory is capable of handling. Checking (on the order of bi-weekly) could prevent losses and/or expedite recovery from most of the datalogger downtime.

## REFERENCES

**Berg, R., and T. Johnson** (1983) Revised procedure for pavement design under seasonal frost conditions. CRREL Special Report 83-27, U.S. Army Cold Regions Research and Engineering Laboratory, Hanover, New Hampshire.

**Casagrande, A.C.** (1931) Discussion of frost heaving. *Proceedings, Highway Research Board*, **11**: 168–172.

**Henry, K.S., and J.C. Stormont** (2000) “Geocomposite capillary barrier drain,” U.S. Patent Office, Patent No. 6,152,653, November 28, 2000.

**Henry, K.S., J.C. Stormont, L.A. Barna, and R.D. Ramos** (2002) Geocomposite capillary barrier drain for unsaturated drainage of pavements. In *Proceedings, 7th International Conference on Geosynthetics* (Delmas, Gourc, and Girard, ed.). Lisse, Netherlands: Swets and Zeitlinger, p. 877–880.

**Webster, S., D. Grau, and T. Williams** (1992) Description and application of dual mass dynamic cone penetrometer. Instruction Report GL-92-3, U.S. Army Waterways Experiment Station, Vicksburg, Mississippi.

## APPENDIX A: SOIL TEMPERATURES IN WINDSOR AND WESTFORD, VERMONT, 2002 AND 2003

This appendix includes graphs of temperatures recorded by the U.S. Army Cold Regions Research and Engineering Laboratory in Windsor Areas 1 and 2, and by Applied Research Associates, Inc., in Windsor Area 4 and Westford, Vermont. There is some uncertainty about the proper assignment of depths to the temperature sensors in Windsor, Area 1, Separator, at depths of 18, 22, 26, 30 and 36 in.

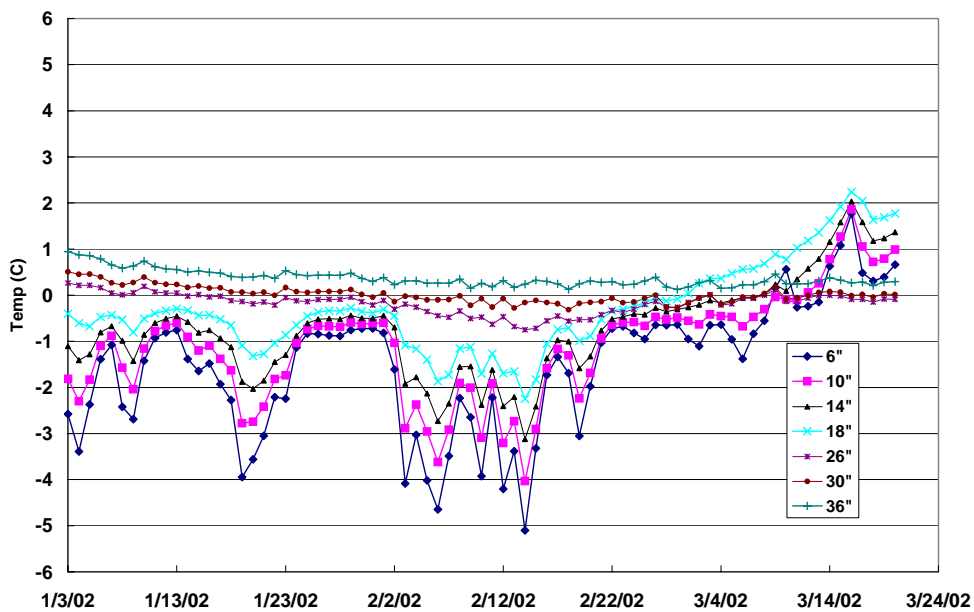


Figure A1. Windsor, Area 1, Control East, 2002 season.

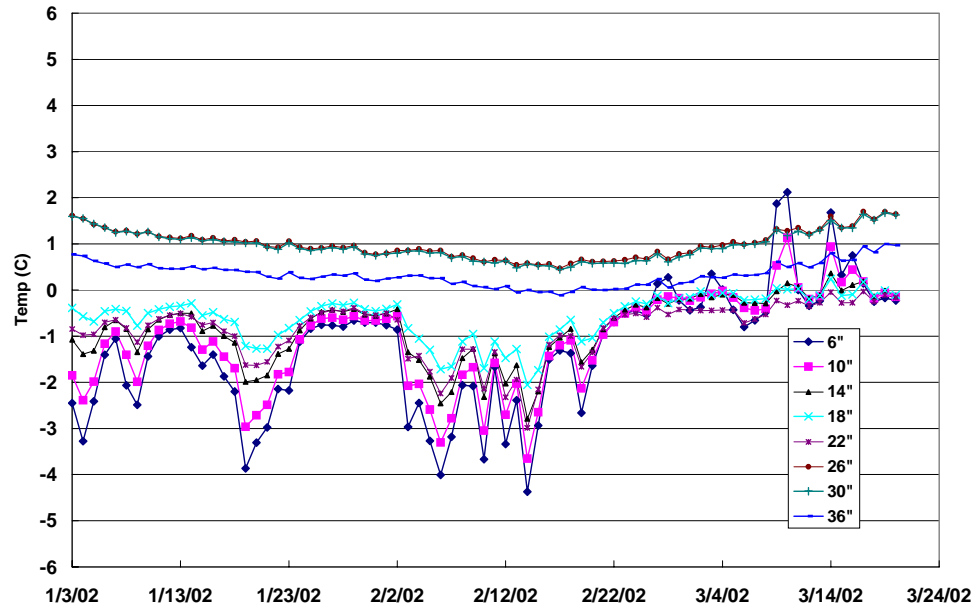


Figure A2. Windsor, Area 1, Separator, 2002 season.

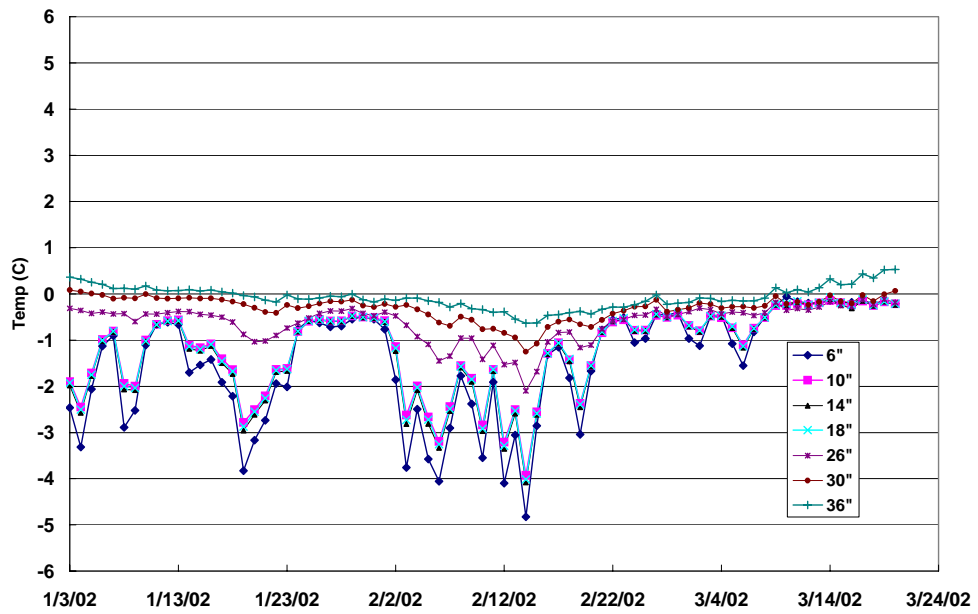


Figure A3. Windsor, Area 1, Control West, 2002 season.

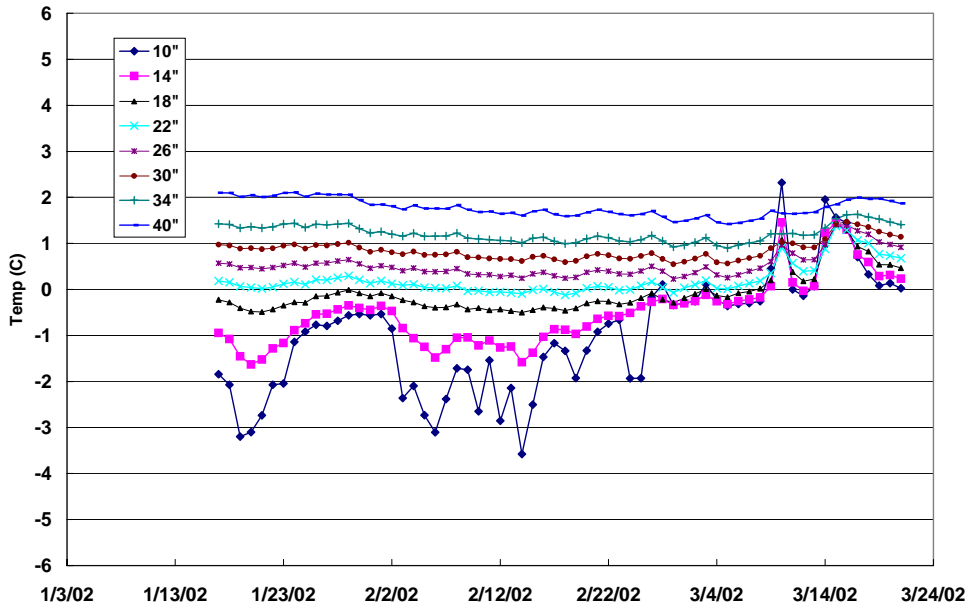


Figure A4. Windsor, Area 2, Control East, 2002 season.

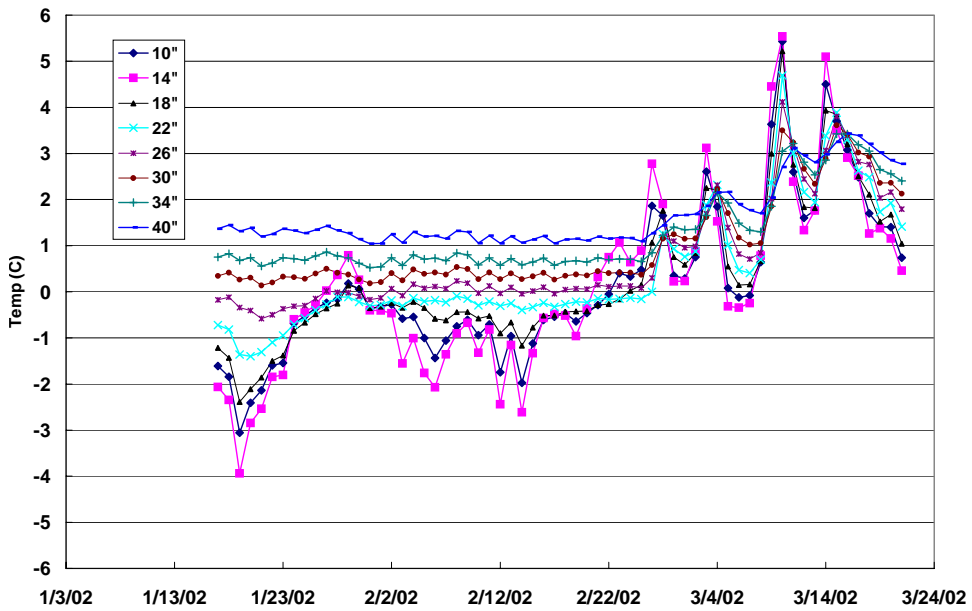


Figure A5. Windsor, Area 2, Drain, 2002 season.

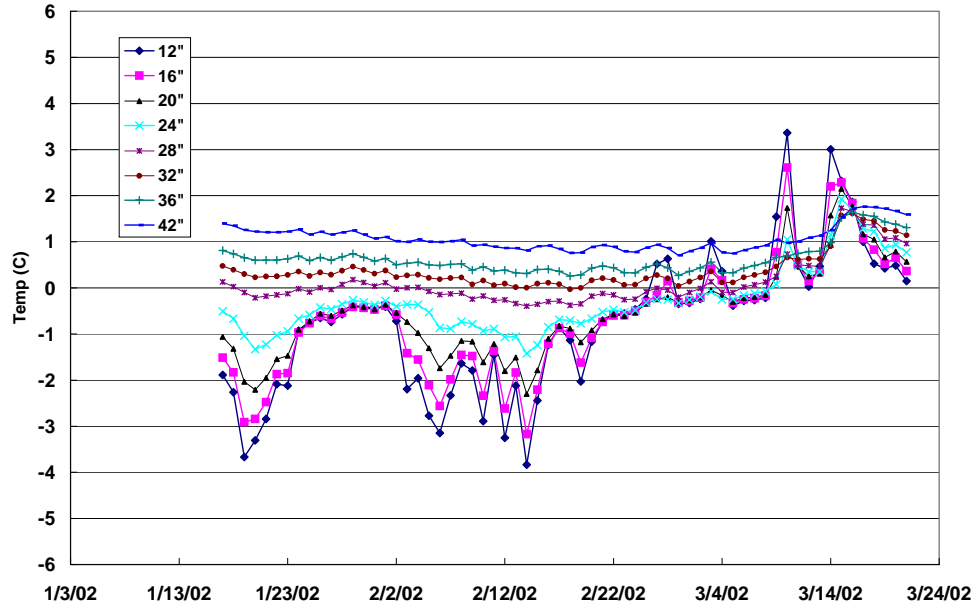


Figure A6. Windsor, Area 2, Grid, 2002 season.

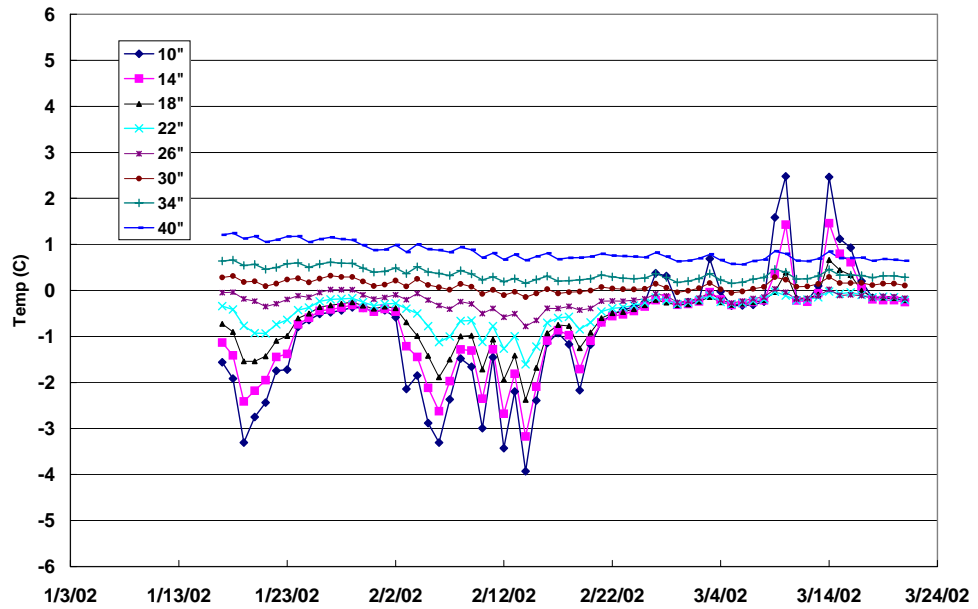


Figure A7. Windsor, Area 2, Control West, 2002 season.

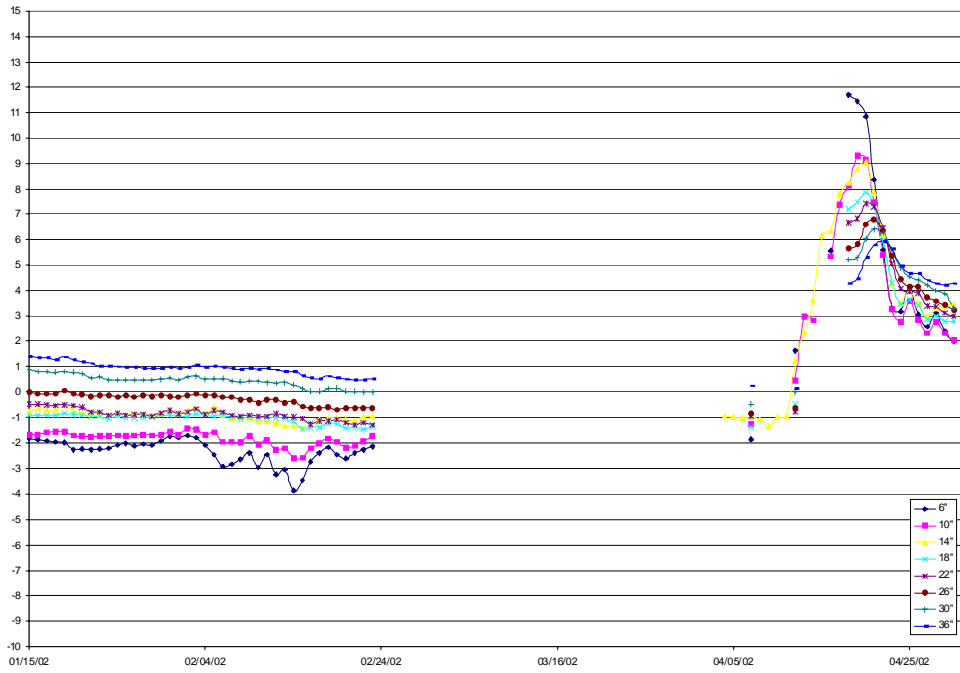


Figure A8. Windsor, Area 4, Control Middle, southbound lane, 2002 season.

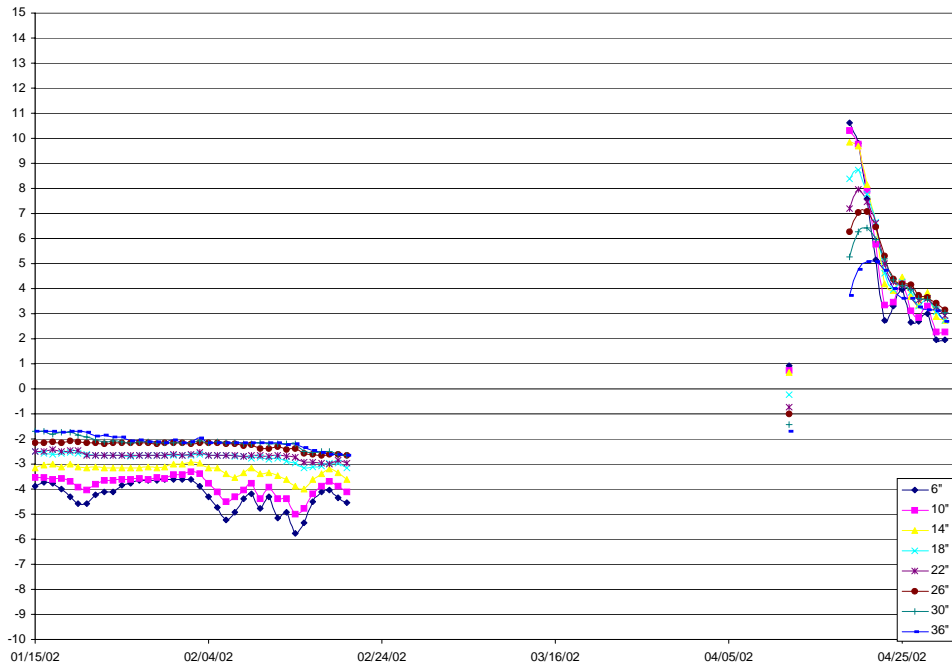


Figure A9. Windsor, Area 4, Control Middle, centerline, 2002 season.

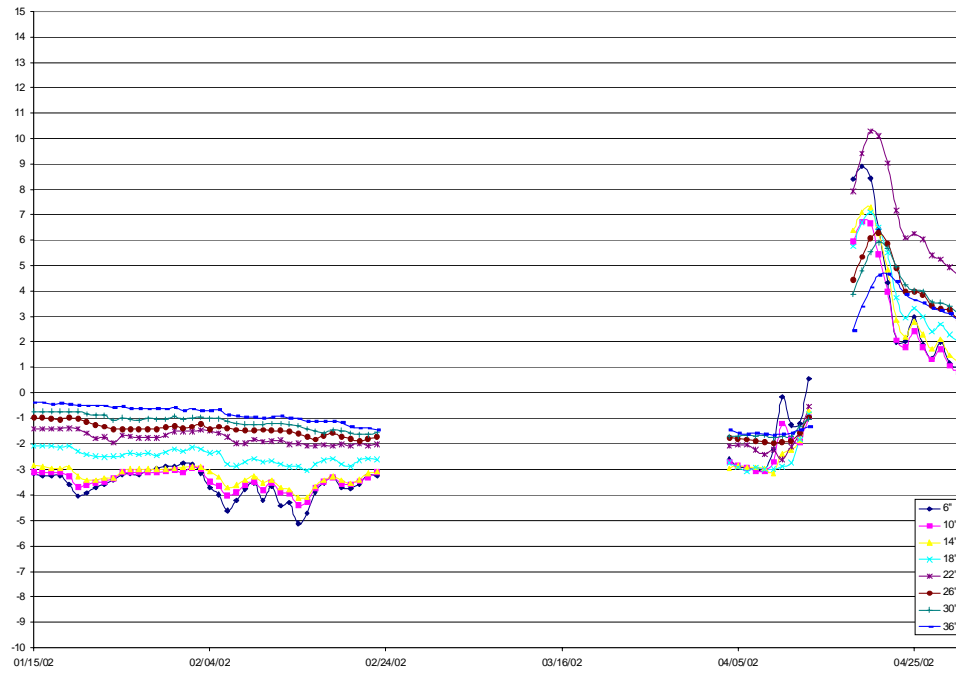


Figure A10. Windsor, Area 4, Control Middle, centerline, 2002 season.

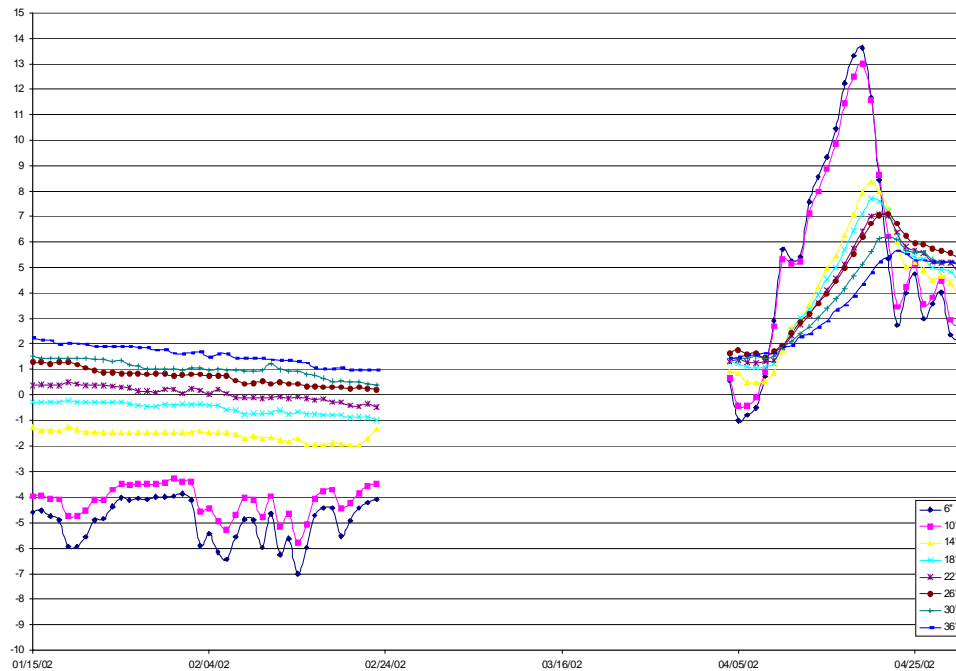


Figure A11. Windsor, Area 4, GCBD, 2002 season.

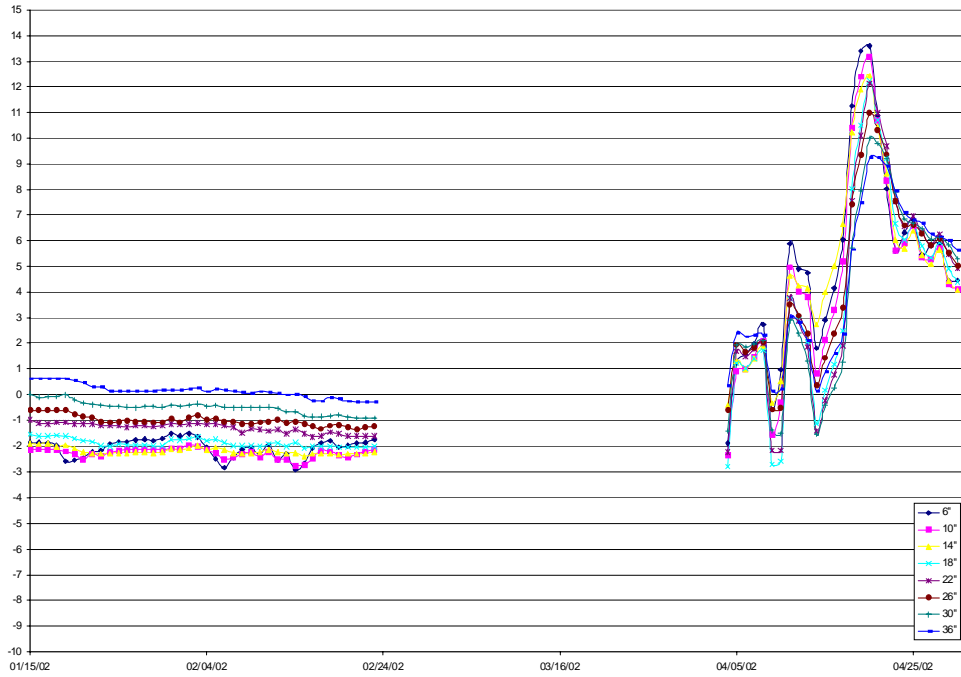


Figure A12. Windsor, Area 4, Control West, 2002 season.

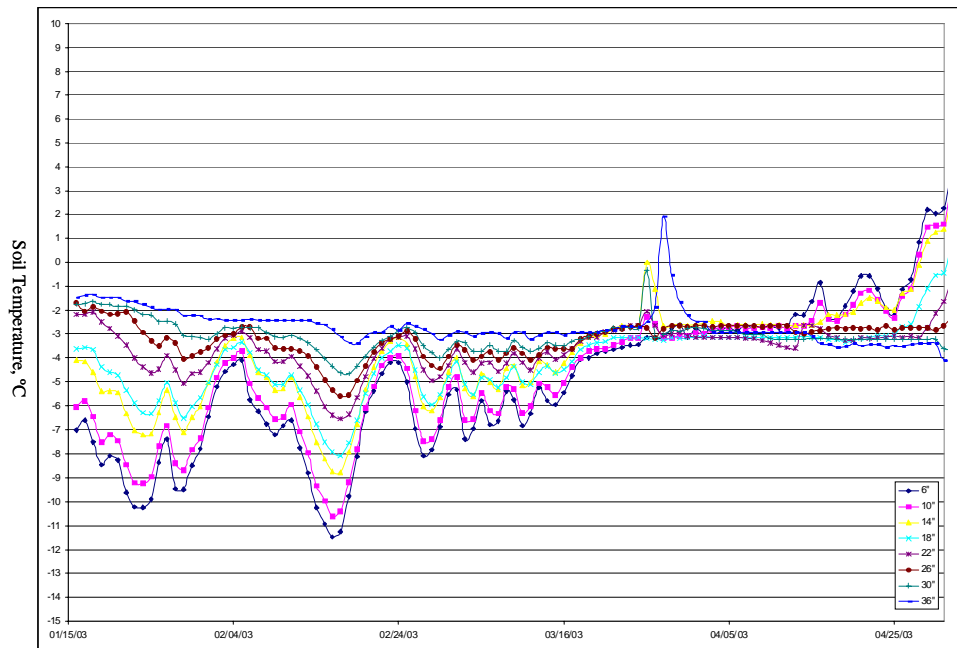


Figure A13. Windsor, Area 4, Separator, 2003 season.

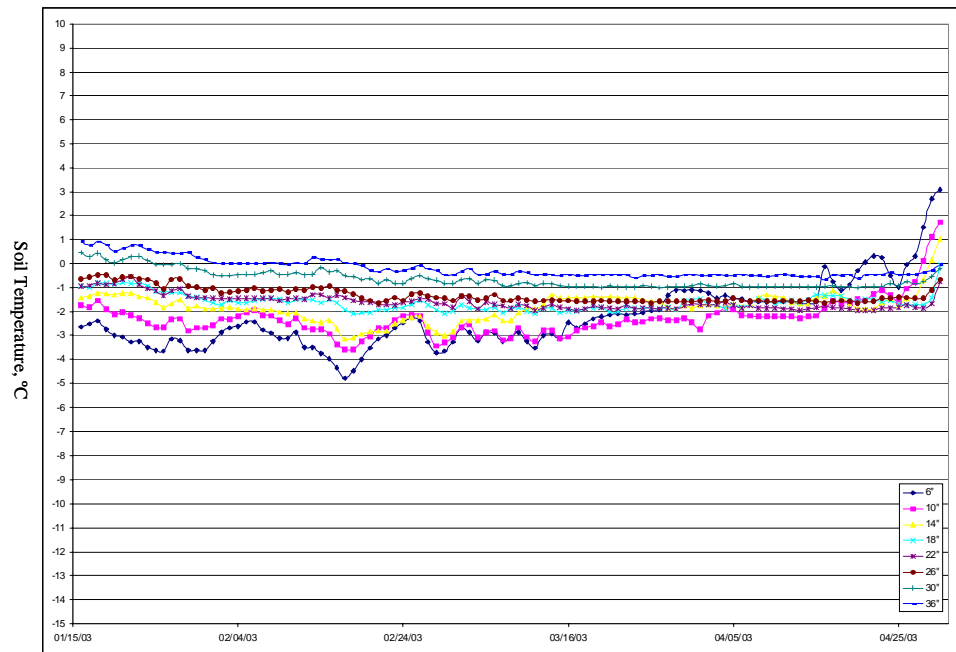


Figure A14. Windsor, Area 4, Control Middle, southbound lane, 2003 season.

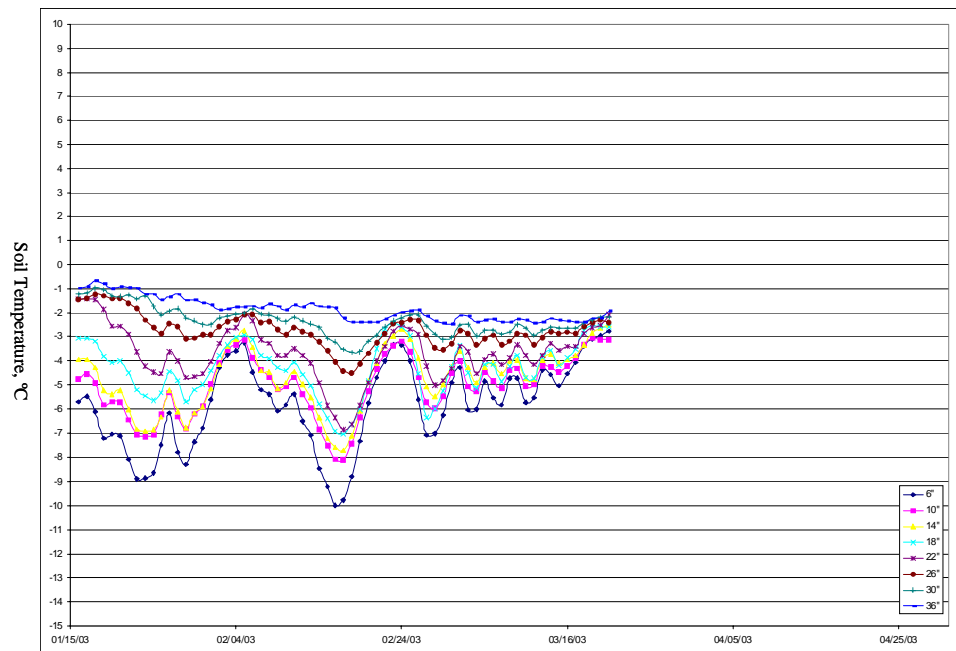


Figure A15. Windsor, Area 4, Control Middle, northbound lane, 2003 season.

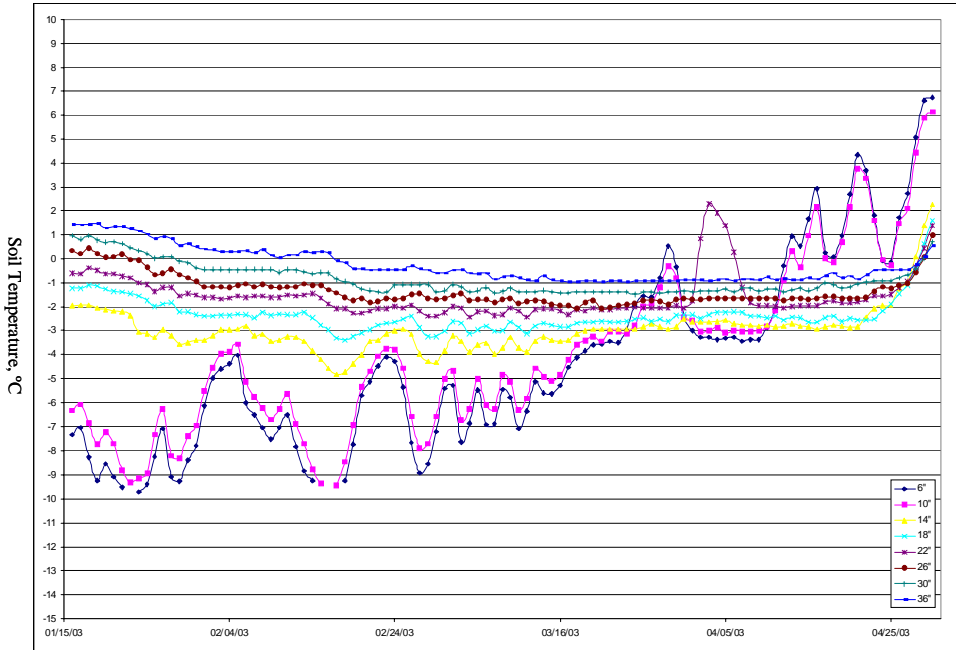


Figure A16. Windsor, Area 4, GCBD, 2003 season.

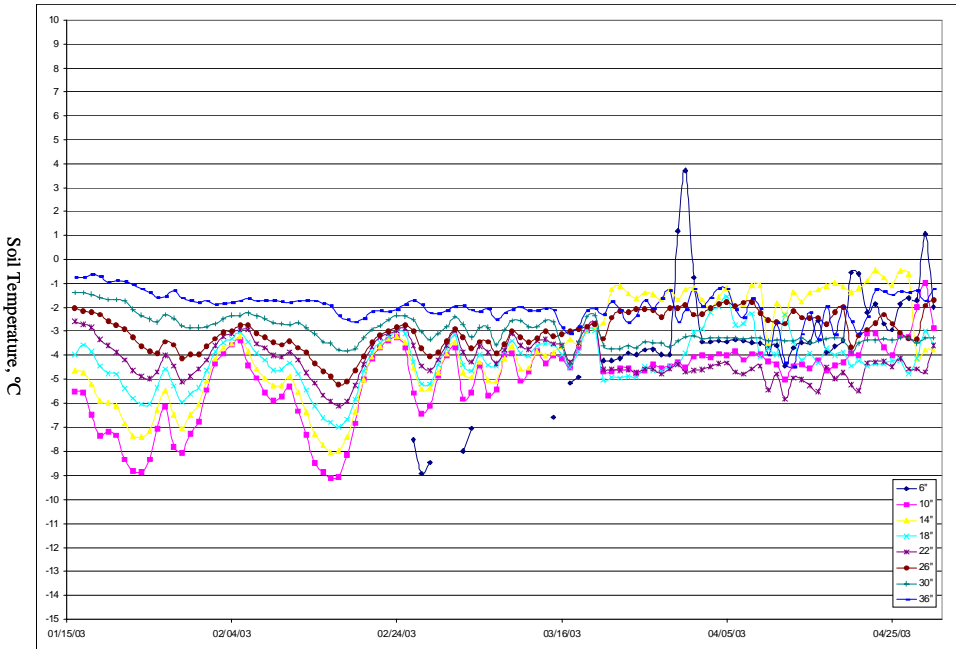


Figure A17. Windsor, Area 4, Control West, 2003 season.

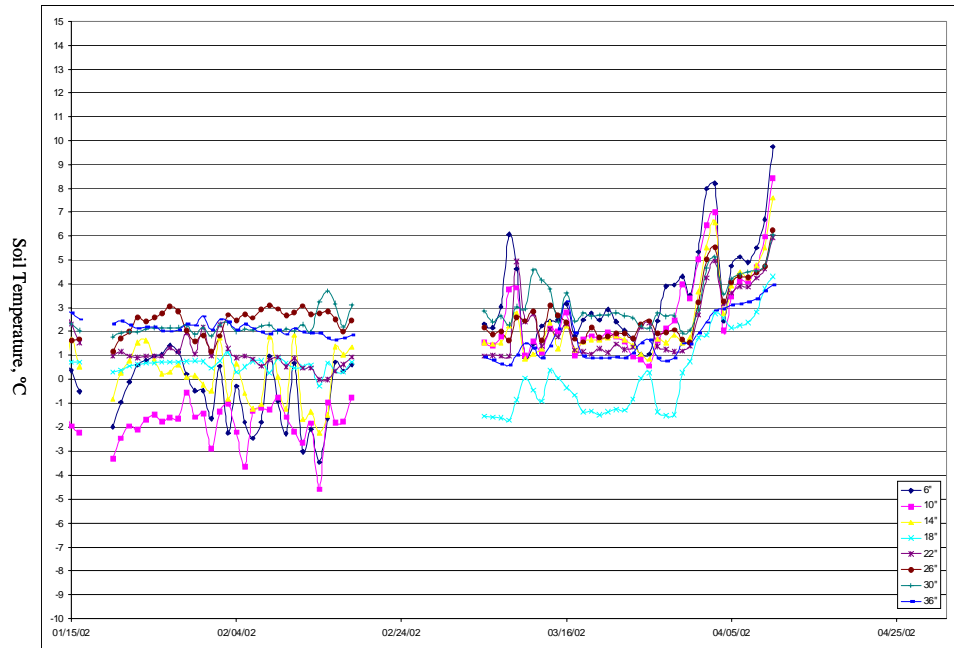


Figure A18. Westford, Geocell 1, 2002 season.

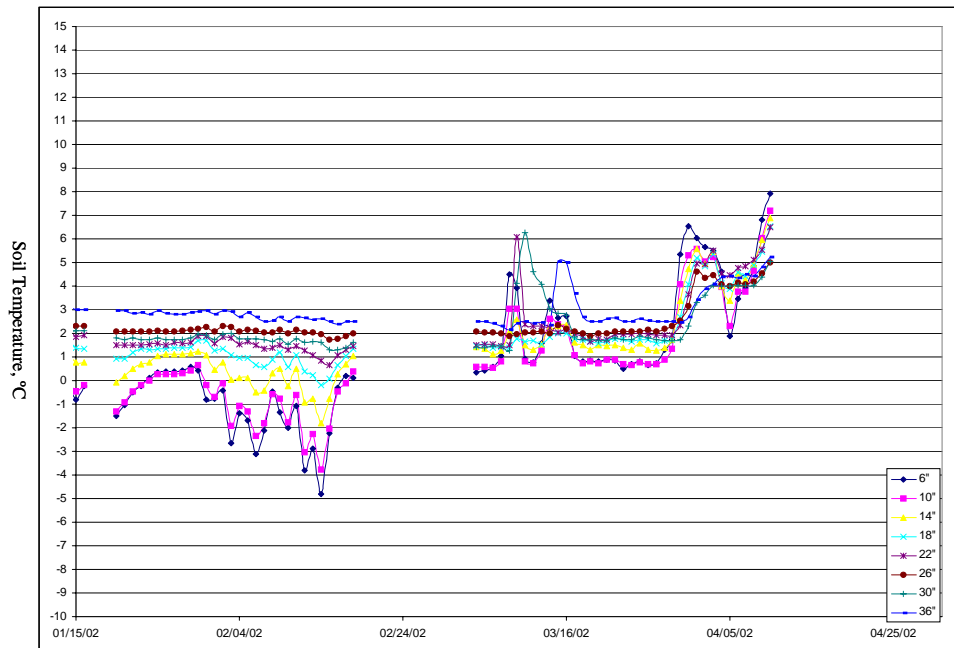


Figure A19. Westford, Control 1, 2002 season.

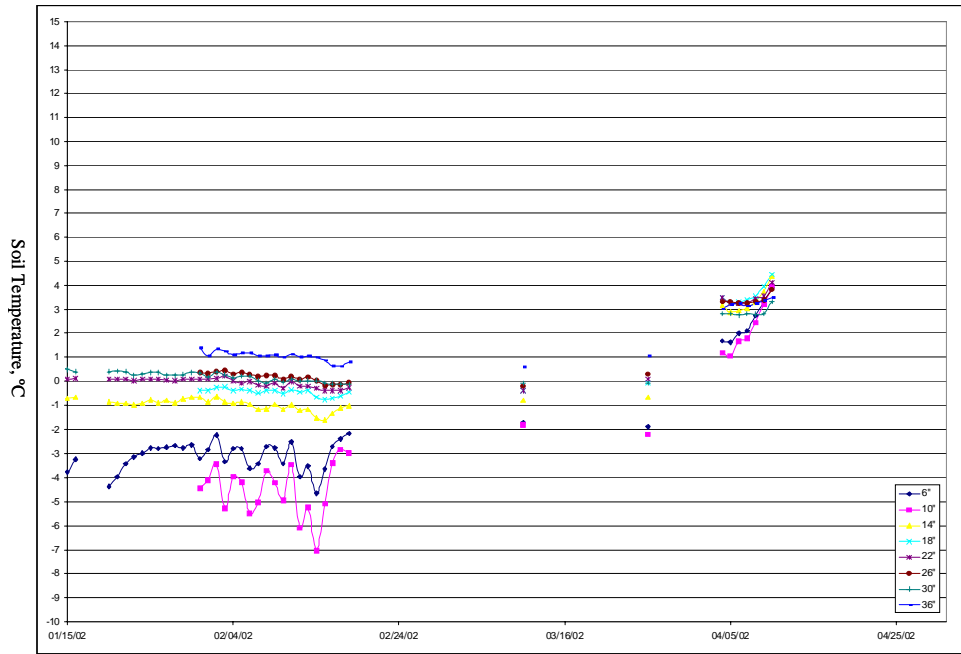


Figure A20. Westford, Geocell 2, 2002 season.

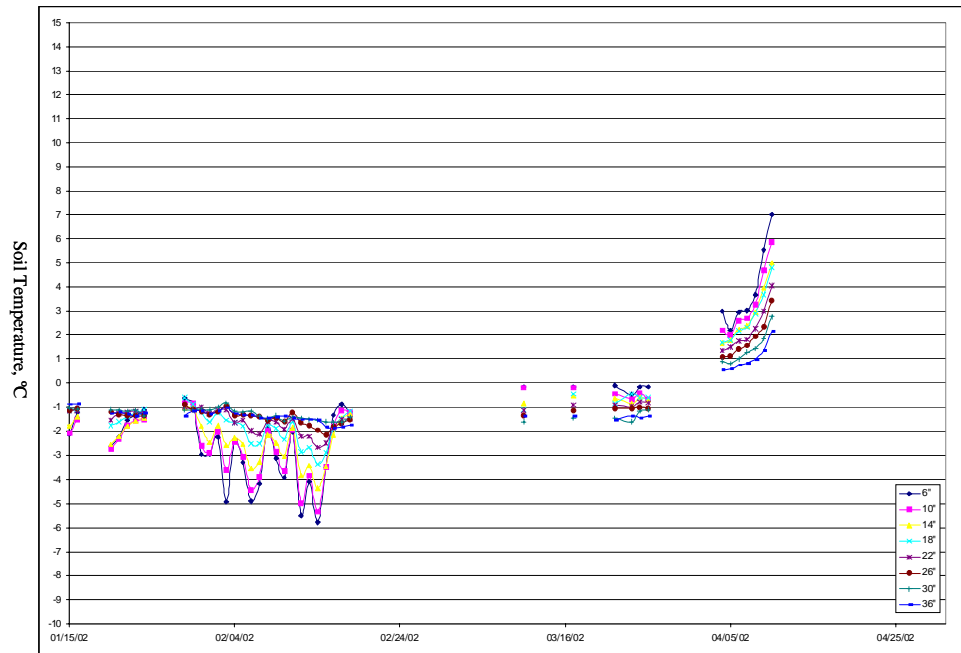


Figure A21. Westford, Drain, 2002 season.

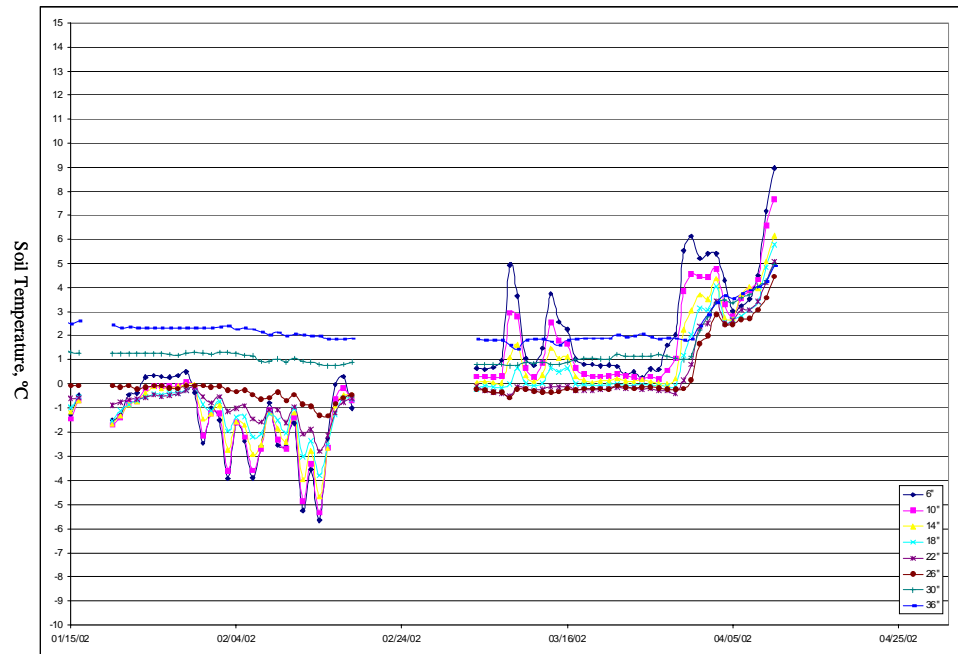


Figure A22. Westford, Control 3, 2002 season.

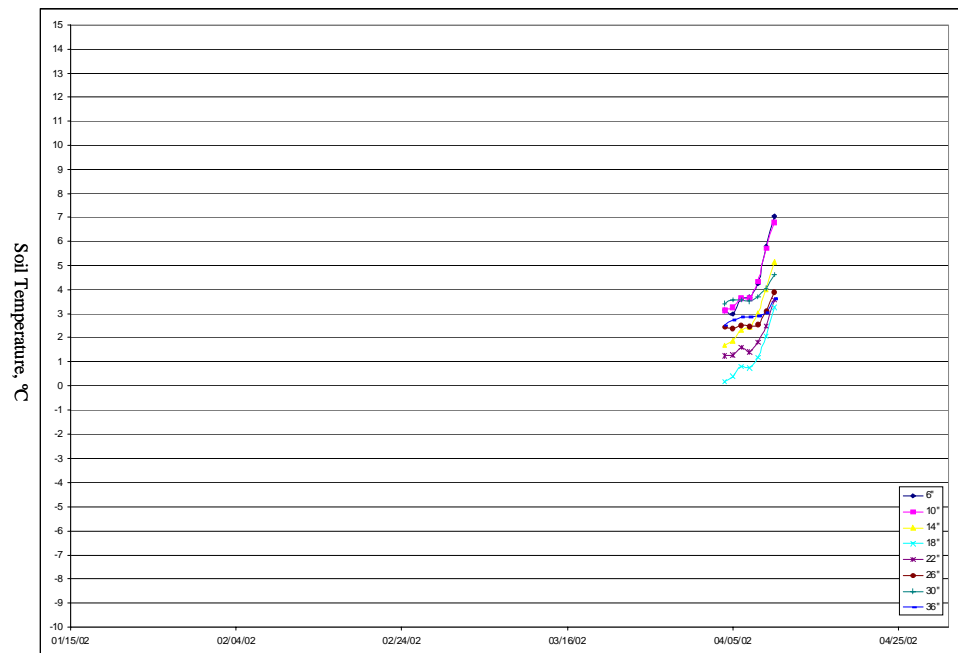


Figure A23. Westford, Geogrid, 2002 season.

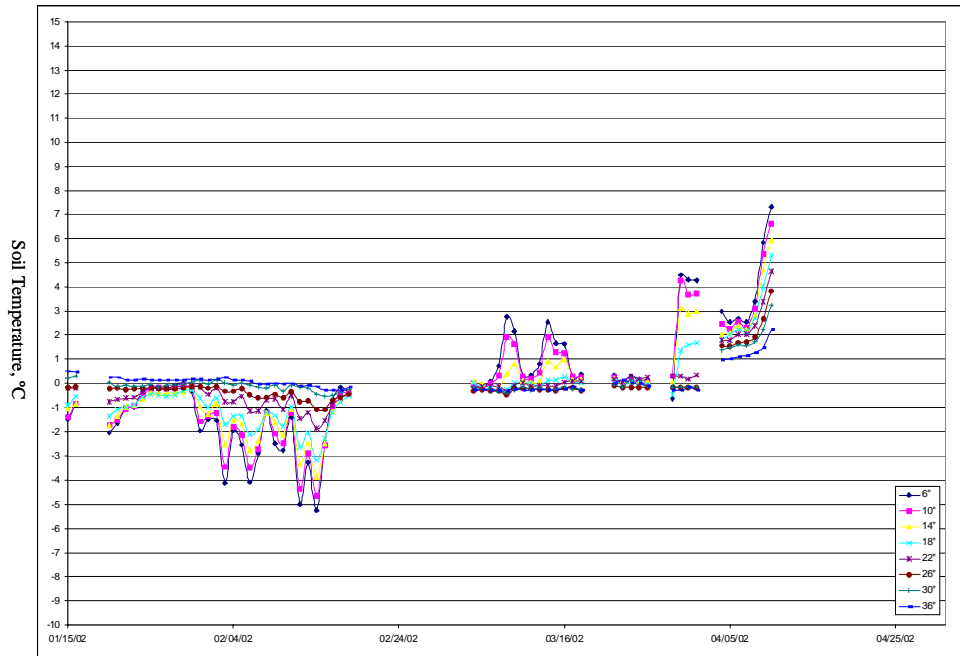


Figure A24. Westford, Cement, 2002 season.

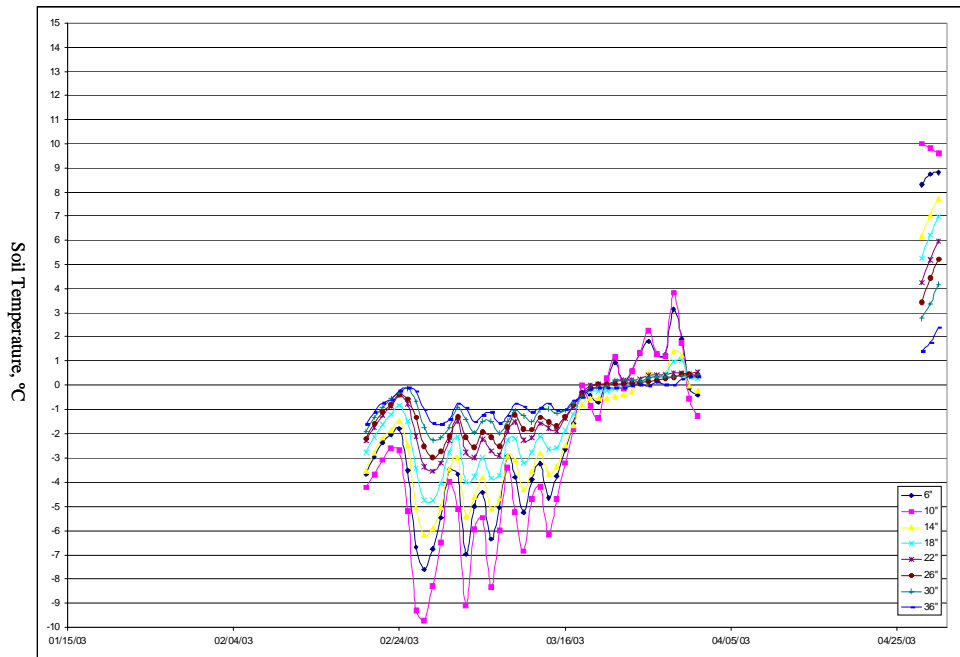


Figure A25. Westford, Geocell 1, 2003 season.

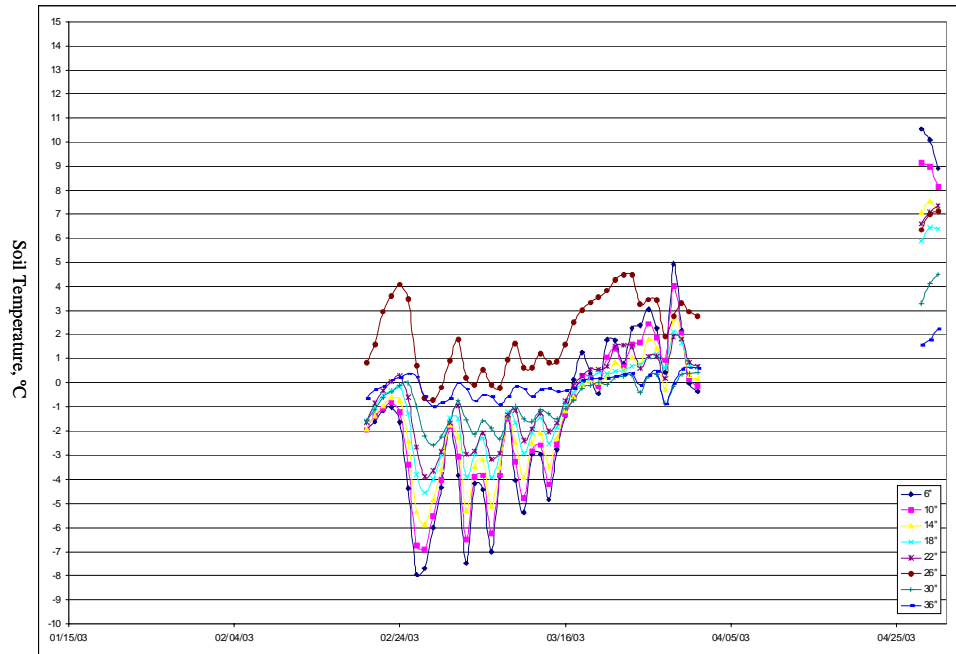


Figure A26. Westford, Control 1, 2003 season.

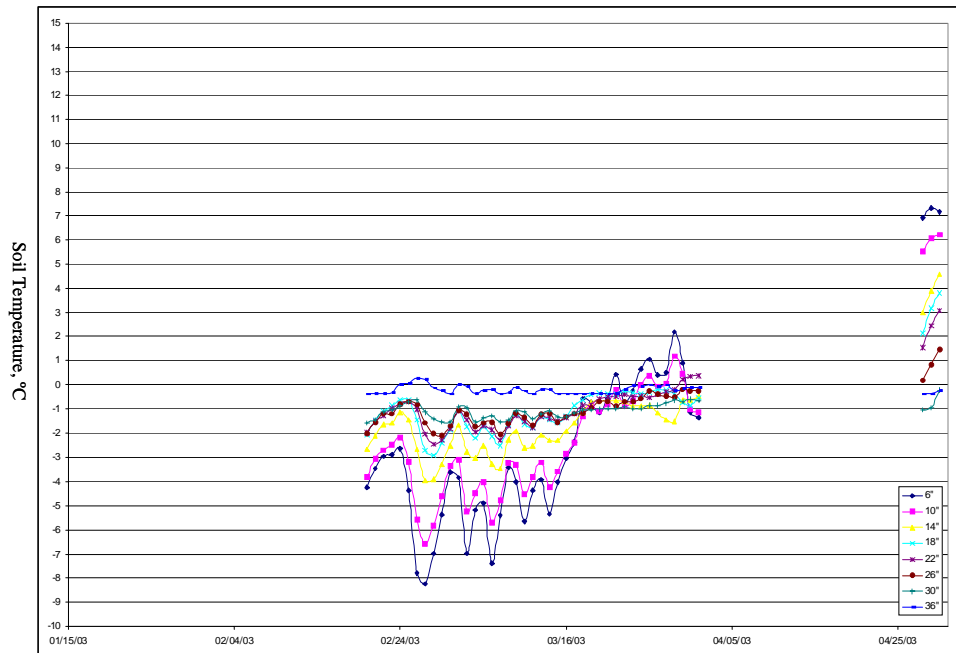


Figure A27. Westford, Geocell 2, 2003 season.

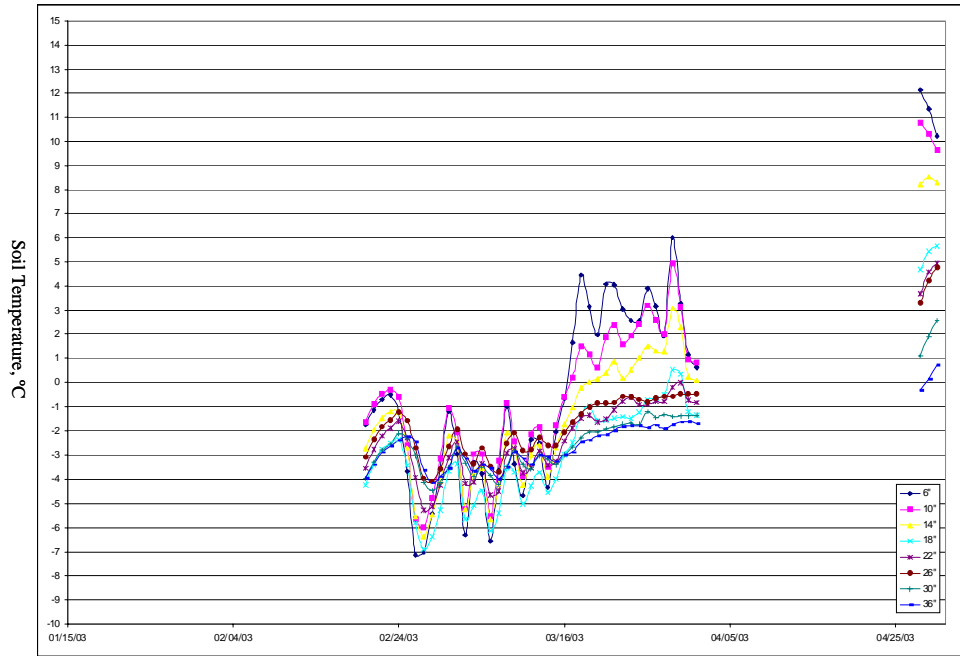


Figure A28. Westford, Drain, 2003 season.

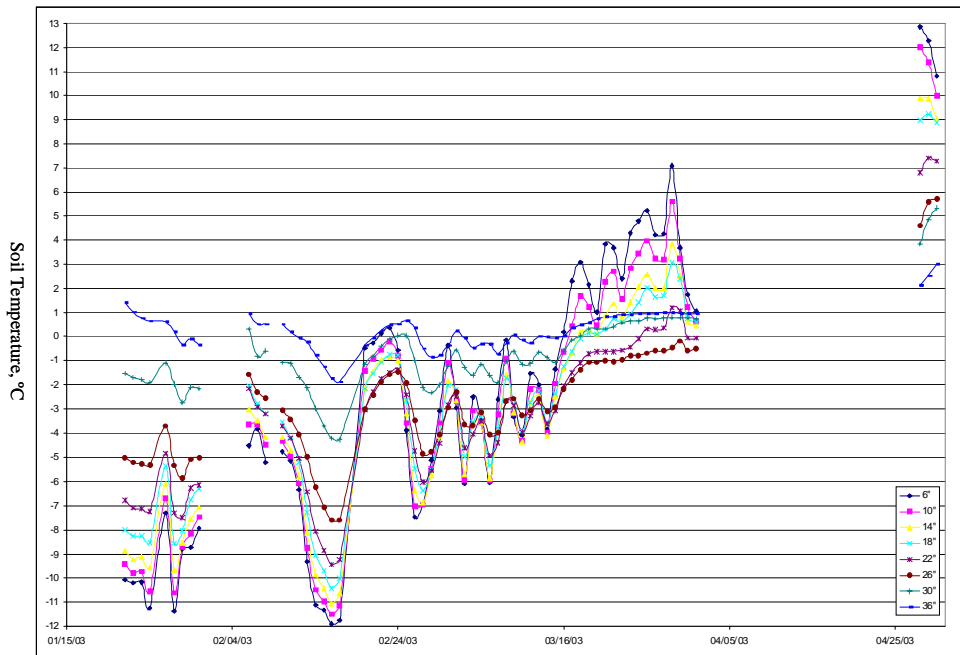


Figure A29. Westford, Control 3, 2003 season.

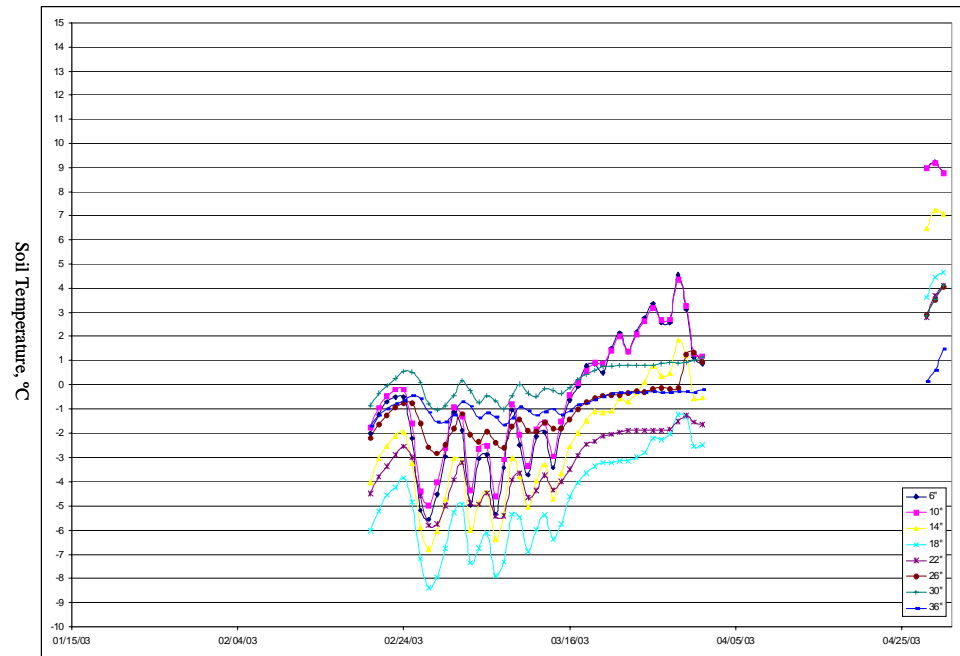


Figure A30. Westford, Geogrid, 2003 season.

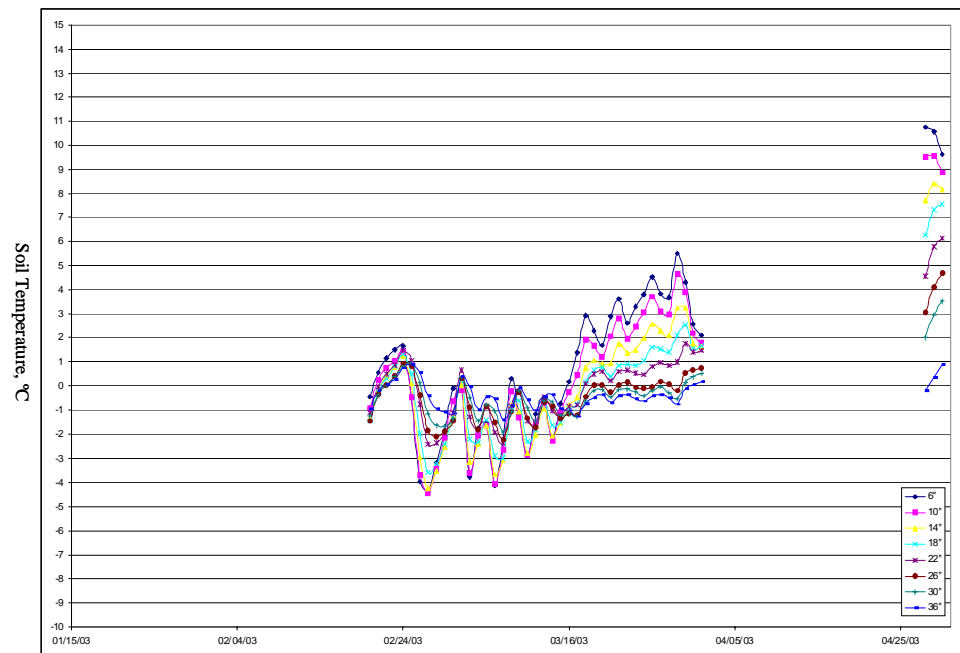


Figure A31. Westford, Cement, 2003 season.

## APPENDIX B: PHOTOGRAPHS OF TEST SECTIONS TAKEN DURING MUD SEASON IN 2002 AND 2003.

### B1. INTRODUCTION

Digital images or photographs were taken on every day that test sections were inspected. Photographs were subsequently scanned to make computer images. The 2002 images often included a 1 ft-long, 2×4-in. board to highlight rutting. We noted that the “edges” of the test sections were hard to delineate in these images. Therefore, in 2003, the ends of the test sections were marked with traffic cones.

### B2. 2002 IMAGES, WINDSOR, VERMONT

#### B2.1 Area 1



4 March 2002, Area 1, CE, image 1.



4 March 2002, Area 1, CE, image 2.



4 March 2002, Area 1, CW, image 1.



4 March 2002, Area 1, CW, image 2.



4 March 2002, Area 1, Separator, image 1.



4 March 2002, Area 1, Separator, image 2.



11 March 2002, Area 1, CE, image 1.



11 March 2002, Area 1, CE, image 2.



11 March 2002, Area 1, CW, image 1.



11 March 2002, Area 1, CW, image 2.



11 March 2002, Area 1, Separator, image 1.



11 March 2002, Area 1, Separator, image 2.



29 March 2002, Area 1, CE, image 1.



29 March 2002, Area 1, CE, image 2.



29 March 2002, Area 1, CW, image 1.



29 March 2002, Area 1, CW, image 2.



29 March 2002, Area 1, Separator, image 1.



29 March 2002, Area 1, Separator, image 2.



2 April 2002, Area 1, CE image 1.



2 April 2002, Area 1, CE image 2.



2 April 2002, Area 1, CE image 3.



2 April 2002, Area 1, CW image 1.



2 April 2002, Area 1, CW image 2.



2 April 2002, Area 1, Separator, image 1.



2 April 2002, Area 1, Separator, image 2.

*B.2.2 Area 2*



**4 March 2002, Area 2, CE, image 1.**



**4 March 2002, Area 2, CE, image 2.**



**4 March 2002, Area 2, CW, image 1.**



**4 March 2002, Area 2, CW, image 2.**



**4 March 2002, Area 2, Drain, image 1.**



**4 March 2002, Area 2, Drain, image 2.**



4 March 2002, Area 2, Grid, image 1.



4 March 2002, Area 2, Grid, image 2.



11 March 2002, Area 2, CE, image 1.



11 March 2002, Area 2, CE, image 2.



11 March 2002, Area 2, CW, image 1.



11 March 2002, Area 2, CW, image 2.



11 March 2002, Area 2, CW, image 3.



11 March 2002, Area 2, Drain, image 1.



11 March 2002, Area 2, Drain, image 2.



11 March 2002, Area 2, Drain, image 3.



11 March 2002, Area 2, Grid, image 1.



11 March 2002, Area 2, Grid, image 2.



11 March 2002, Area 2, Grid, image 3.



11 March 2002, Area 2, Grid, image 4.



29 March 2002, Area 2, CE, image 1.



29 March 2002, Area 2, CE, image 2.



29 March 2002, Area 2, CW, image 1.



29 March 2002, Area 2, CW, image 2.



29 March 2002, Area 2, Drain, image 1.



29 March 2002, Area 2, Drain, image 2.



29 March 2002, Area 2, Grid, image 1.



29 March 2002, Area 2, Grid, image 2.



2 April 2002, Area 2, CE, image 1.



2 April 2002, Area 2, CE, image 2.



2 April 2002, Area 2, CW, image 1.



2 April 2002, Area 2, CW, image 2.



2 April 2002, Area 2, Drain, image 1.



2 April 2002, Area 2, Drain, image 2.



2 April 2002, Area 2, Grid, image 1.



2 April 2002, Area 2, Grid, image 2.

*B.2.3 Area 3*



4 March 2002, Area 3, CE, image 1.



4 March 2002, Area 3, CE, image 2.



4 March 2002, Area 3, Cement, image 1.



4 March 2002, Area 3, Cement, image 2.



4 March 2002, Area 3, CM, image 1.



4 March 2002, Area 3, CM, image 2.



4 March 2002, Area 3, CW, image 1.



4 March 2002, Area 3, CW, image 2.



4 March 2002, Area 3, Geowrap, image 1.



4 March 2002, Area 3, Geowrap, image 2.



4 March 2002, Area 3, view.



11 March 2002, Area 3, CE, image 1.



11 March 2002, Area 3, CE, image 2.



11 March 2002, Area 3, Cement, image 1.



11 March 2002, Area 3, Cement, image 2.



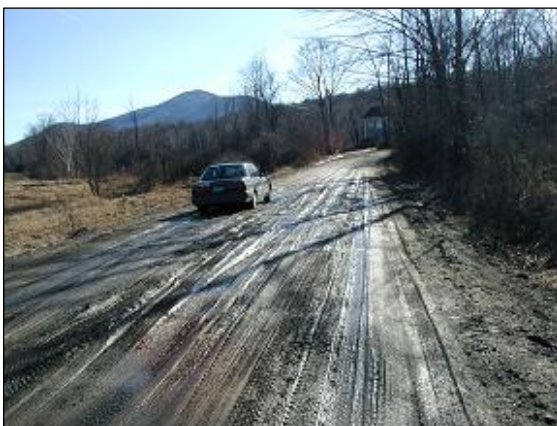
11 March 2002, Area 3, CM, image 1.



11 March 2002, Area 3, CM, image 2.



11 March 2002, Area 3, CW, image 1.



11 March 2002, Area 3, CW, image 2.



11 March 2002, Area 3, Geowrap, image 1.



11 March 2002, Area 3, Geowrap, image 2.



11 March 2002, Area 3, overview.



29 March 2002, Area 3, CE, image 1.



29 March 2002, Area 3, CE, image 2.



29 March 2002, Area 3, Cement, image 1.



29 March 2002, Area 3, Cement, image 2.



29 March 2002, Area 3, CM, image 1.



29 March 2002, Area 3, CM, image 2.



29 March 2002, Area 3, CM, image 3.



29 March 2002, Area 3, CW, image 1.



29 March 2002, Area 3, CW, image 2.



29 March 2002, Area 3, Geowrap, image 1.



29 March 2002, Area 3, Geowrap, image 2.



2 April 2002, Area 3, CE, image 1.



2 April 2002, Area 3, CE, image 2.



2 April 2002, Area 3, Cement, image 1.



2 April 2002, Area 3, Cement, image 2.



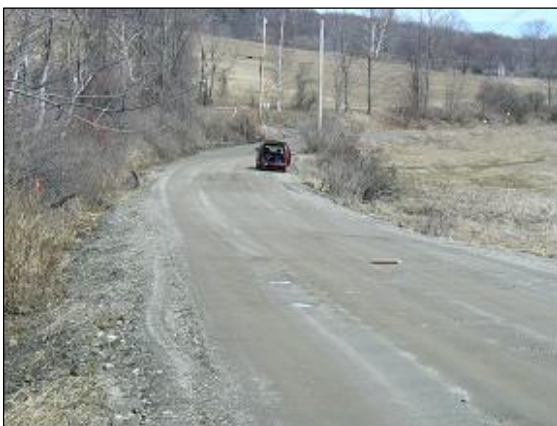
2 April 2002, Area 3, CM, image 1.



2 April 2002, Area 3, CM, image 2.



2 April 2002, Area 3, CW, image 1.



2 April 2002, Area 3, CW, image 2.



2 April 2002, Area 3, Geowrap, image 1.



2 April 2002, Area 3, Geowrap, image 2.

*B.2.4 Area 4*



25 February 2002, Area 4, CM, image 2.



25 February 2002, Area 4, CM, image 1.



25 Feb. 2002, Area 4, Separator, image 1.



25 Feb. 2002, Area 4, Separator, image 2.



25 February 2002, Area 4, GCBD, image 1.



25 February 2002, Area 4, GCBD, image 2.



25 February 2002, Area 4, CW.



4 March 2002, Area 4, CE, image 1.



4 March 2002, Area 4, CE, image 2.



4 March 2002, Area 4, CM, image 1.



4 March 2002, Area 4, CM, image 2.



4 March 2002, Area 4, CW, image 1.



4 March 2002, Area 4, CW, image 2.



4 March 2002, Area 4, GCBD, image 1.



4 March 2002, Area 4, GCBD, image 2.



4 March 2002, Area 4, Separator, image 1.



4 March 2002, Area 4, Separator, image 2.



11 March 2002, Area 4, CE, image 1.



11 March 2002, Area 4, CE, image 2.



11 March 2002, Area 4, CE, image 3.



11 March 2002, Area 4, CE, image 4.



11 March 2002, Area 4, CM, image 1.



11 March 2002, Area 4, CM, image 2.



11 March 2002, Area 4, CW, image 1.



11 March 2002, Area 4, CW, image 2.



11 March 2002, Area 4, GCBD, image 1.



11 March 2002, Area 3, GCBD, image 2.



11 March 2002, Area 3, Separator, image 1.



11 March 2002, Area 3, Separator, image 2.



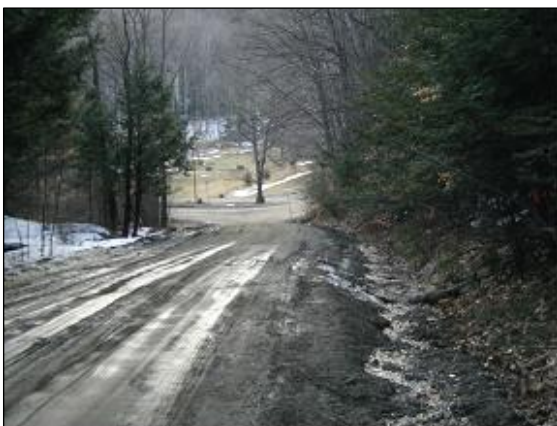
11 March 2002, Area 3, Separator, image 3.



15 March 2002, Area 4, CM, image 1.



15 March 2002, Area 4, CM, image 2.



15 March 2002, Area 4, CM, image 3.



15 March 2002, Area 4, GCDB, image 1.



15 March 2002, Area 4, GCDB, image 2.



15 March 2002, Area 4, GCDB, image 3.



29 March 2002, Area 4, CE, image 1.



29 March 2002, Area 4, CE, image 2.



29 March 2002, Area 4, CM, image 1.



29 March 2002, Area 4, CM, image 2.



29 March 2002, Area 4, CW, image 1.



29 March 2002, Area 4, CW, image 2.



29 March 2002, Area 4, GCBD, image 1.



29 March 2002, Area 4, GCBD, image 2.



29 March 2002, Area 4, GCBD, image 3.



29 March 2002, Area 4, Separator, image 1.



29 March 2002, Area 4, Separator, image 2.



2 April 2002, Area 4, CE, image 1.



2 April 2002, Area 4, CE, image 2.



2 April 2002, Area 4, CE, image 3.



2 April 2002, Area 4, CM, image 1.



2 April 2002, Area 4, CM, image 2.



2 April 2002, Area 4, CW, image 1.



2 April 2002, Area 4, CW, image 2.



2 April 2002, Area 4, GCBD, image 1.



2 April 2002, Area 4, GCBD, image 2.



2 April 2002, Area 4, New Gravel, image 1.



2 April 2002, Area 4, New Gravel, image 2.



2 April 2002, Area 4, New Gravel, image 3.



2 April 2002, Area 4, Separator, image 1.



2 April 2002, Area 4, Separator, image 2.

### B.3 2003 IMAGES

#### B.3.1 Area 1



17 March 2003, Area 1, CE, image 1.



17 March 2003, Area 1, CE, image 2.



17 March 2003, Area 1, CW, image 1.



17 March 2003, Area 1, CW, image 2.



17 March 2003, Area 1, CW, image 3.



17 March 2003, Area 1, CW, image 4.



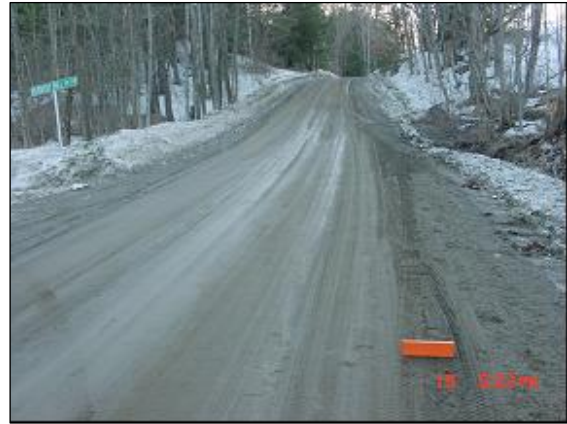
17 March 2003, Area 1, Separator, image 1.



17 March 2003, Area 1, Separator, image 2.



19 March 2003, Area 1, CE, image 1.



19 March 2003, Area 1, CE, image 2.



19 March 2003, Area 1, CW, image 1.



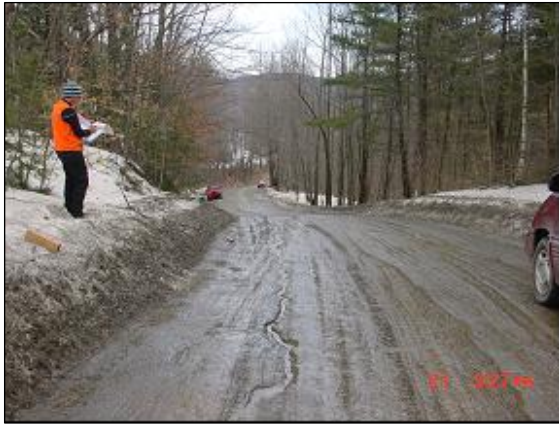
19 March 2003, Area 1, Separator.



21 March 2003, Area 1, CE, image 1.



21 March 2003, Area 1, CE, image 2.



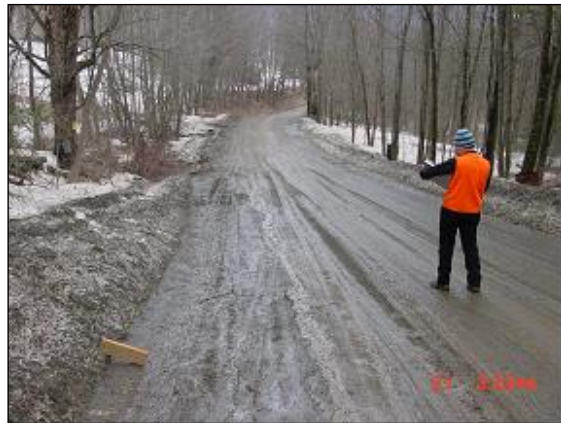
21 March 2003, Area 1, CW, image 1.



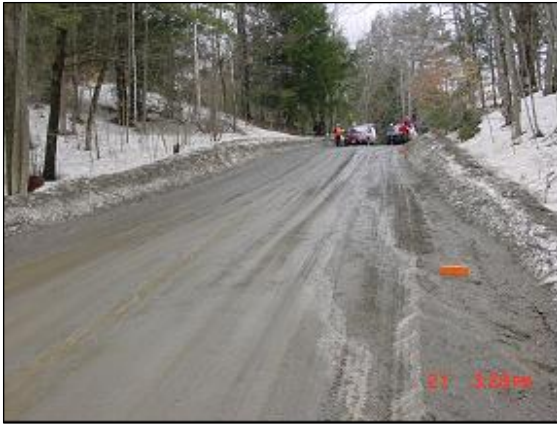
21 March 2003, Area 1, CW, image 2.



21 March 2003, Geotextile.



21 March 2003, Area 1, Separator, image 1.



21 March 2003, Area 1, Separator, image 2.



24 March 2003, Area 1, CE, image 1.



24 March 2003, Area 1, CE, image 2.



24 March 2003, Area 1, Separator-CE.



24 March 2003, Area 1, Separator, image 1.



24 March 2003, Area 1, Separator, image 2.



24 March 2003, Area 1, CW, image 1.



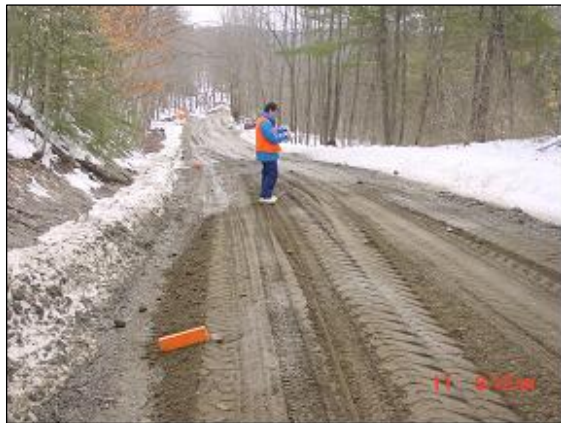
24 March 2003, Area 1, CW, image 2.



11 April 2003, Area 1, CE, image 1.



11 April 2003, Area 1, CE, image 2.



11 April 2003, Area 1, CW, image 1.



11 April 2003, Area 1, CW, image 2.



11 April 2003, Area 1, Separator, image 1.



11 April 2003, Area 1, Separator, image 2.



11 April 2003, Area 1, Separator, image 3.



15 April 2003, Area 1, CE image 1.



15 April 2003, Area 1, CE image 2.



15 April 2003, Area 1, CE image 3.



15 April 2003, Area 1, CW image 1.



15 April 2003, Area 1, CW image 2.



15 April 2003, Area 1, Separator, image 1.



15 April 2003, Area 1, Separator, image 2.

B.3.2 Area 2



17 March 2003, Area 2, CE, image 1.



17 March 2003, Area 2, CE, image 2.



17 March 2003, Area 2, CW, image 1.



17 March 2003, Area 2, CW, image 2.



17 March 2003, Area 2, Drain, image 1.



17 March 2003, Area 2, Drain, image 2.



17 March 2003, Area 2, Grid, image 1.



17 March 2003, Area 2, Grid, image 2.



17 March 2003, Area 2, Overview.



19 March 2003, Area 2, CW.



19 March 2003, Area 2, Drain.



19 March 2003, Area 2, Grid.



21 March 2003, Area 2, CE, image 1.



21 March 2003, Area 2, CE, image 2.



21 March 2003, Area 2, CW, image 1.



21 March 2003, Area 2, CW, image 2.



21 March 2003, Area 2, Drain, image 1.



21 March 2003, Area 2, Drain, image 2.



21 March 2003, Area 2, Grid, image 1.



21 March 2003, Area 2, Grid, image 2.



24 March 2003, Area 2, CE, image 1.



24 March 2003, Area 2, CE, image 2.



24 March 2003, Area 2, Drain, image 1.



24 March 2003, Area 2, Drain, image 2.



24 March 2003, Area 2, Grid, image 1.



24 March 2003, Area 2, Grid, image 2.



24 March 2003, Area 2, CW, image 1.



24 March 2003, Area 2, CW, image 2.



8 April 2003, Area 2, CE, image 1.



8 April 2003, Area 2, CE, image 2.



8 April 2003, Area 2, CW, image 1.



8 April 2003, Area 2, CW, image 2.



8 April 2003, Area 2, CW, image 3.



8 April 2003, Area 2, CW, image 4.



8 April 2003, Area 2, Drain, image 1.



8 April 2003, Area 2, Drain, image 2.



8 April 2003, Area 2, Grid, image 1.



8 April 2003, Area 2, Grid, image 2.



11 April 2003, Area 2, image 1.



11 April 2003, Area 2, image 2.



11 April 2003, Area 2, CW, image 1.



11 April 2003, Area 2, CW, image 2.



11 April 2003, Area 2, CW, image 3.



11 April 2003, Area 2, Drain, image 1.



11 April 2003, Area 2, Drain, image 2.



11 April 2003, Area 2, Grid, image 1.



11 April 2003, Area 2, Grid, image 2.



15 April 2003, Area 2, CE, image 1.



15 April 2003, Area 2, CE, image 2.



15 April 2003, Area 2, CW, image 1.



15 April 2003, Area 2, CW, image 2.



15 April 2003, Area 2, Drain, image 1.



15 April 2003, Area 2, Drain, image 2.



15 April 2003, Area 2, Grid, image 1.



15 April 2003, Area 2, Grid, image 2.

*B.3.3 Area 3*



25 February 2003, Area 3, CE, image 1.



25 February 2003, Area 3, CE, image 2.



25 February 2003, Area 3, Cement, image 1.



25 February 2003, Area 3, Cement, image 2.



25 February 2003, Area 3, CW, image 1.



25 February 2003, Area 3, CW, image 2.



25 February 2003, Area 3, CW, image 3.



25 February 2003, Area 3, Geowrap, image 1.



25 February 2003, Area 3, Geowrap, image 2.



25 February 2003, Area 3, CM, image 2.



17 March 2003, Area 3, CE, image 1.



17 March 2003, Area 3, CE, image 2.



17 March 2003, Area 3, cement, image 1.



17 March 2003, Area 3, cement, image 2.



17 March 2003, Area 3, CM, image 1.



17 March 2003, Area 3, CM, image 2.



17 March 2003, Area 3, CW, image 1.



17 March 2003, Area 3, CW, image 2.



17 March 2003, Area 3, Geowrap, image 1.



17 March 2003, Area 3, Geowrap, image 2.



17 March 2003, Area 3, Overview.



19 March 2003, Area 3, image 1.



19 March 2003, Area 3, image 2.



19 March 2003, Area 3, CE.



19 March 2003, Area 3, Cement.



19 March 2003, Area 3, CM.



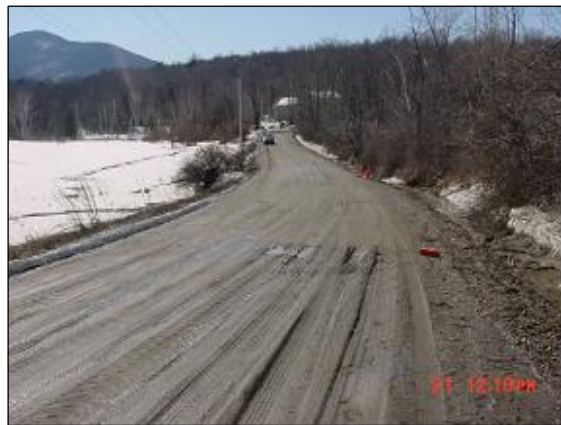
19 March 2003, Area 3, Good view.



21 March 2003, Area 3, CE, image 1.



21 March 2003, Area 3, CE, image 2.



21 March 2003, Area 3, Cement, image 1.



21 March 2003, Area 3, Cement, image 2.



21 March 2003, Area 3, CM, image 1.



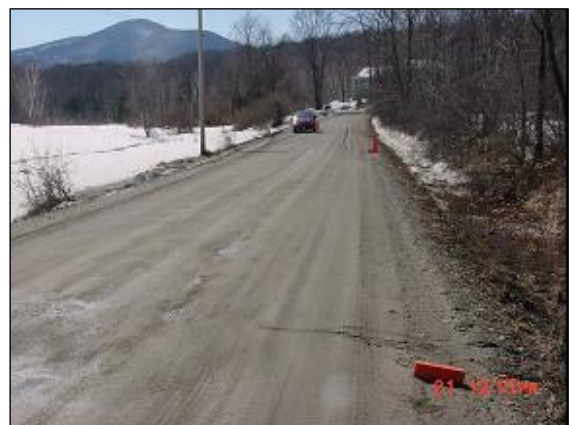
21 March 2003, Area 3, CM, image 2.



21 March 2003, Area 3, CW, image 1.



21 March 2003, Area 3, CW, image 2.



21 March 2003, Area 3, Geowrap, image 1.



21 March 2003, Area 3, Geowrap, image 2.



21 March 2003, Area 3, grader.



24 March 2003, Area 3, CE, image 1.



24 March 2003, Area 3, CE, image 2.



24 March 2003, Area 3, Cement, image 1.



24 March 2003, Area 3, Cement, image 2.



24 March 2003, Area 3, CM, image 1.



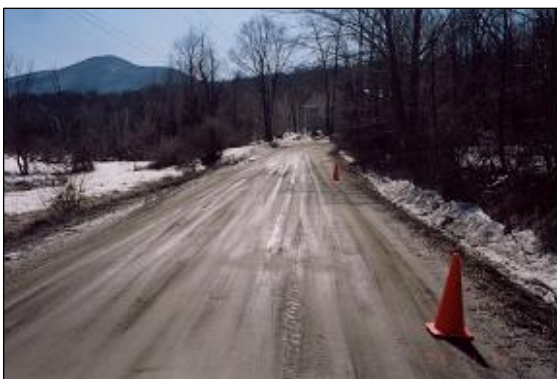
24 March 2003, Area 3, CM, image 2.



24 March 2003, Area 3, Geowrap, image 1.



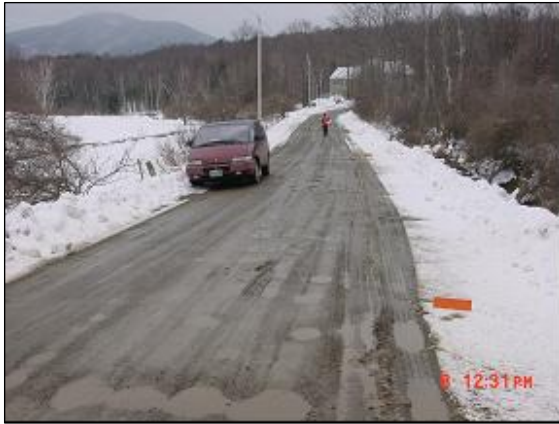
24 March 2003, Area 3, Geowrap, image 2.



24 March 2003, Area 3, CW, image 1.



24 March 2003, Area 3, CW, image 2.



8 April 2003, Area 3, CM, image 1.



8 April 2003, Area 3, CM, image 2.



8 April 2003, Area 3, CW, image 1.



8 April 2003, Area 3, CW, image 2.



8 April 2003, Area 3, Geowrap, image 1.



8 April 2003, Area 3, Geowrap, image 2.



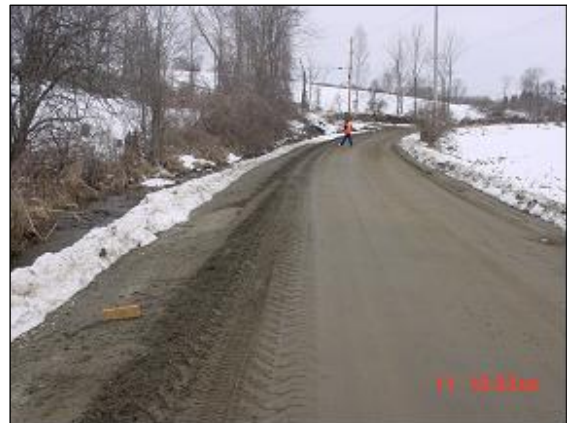
11 April 2003, Area 3, CE, image 1.



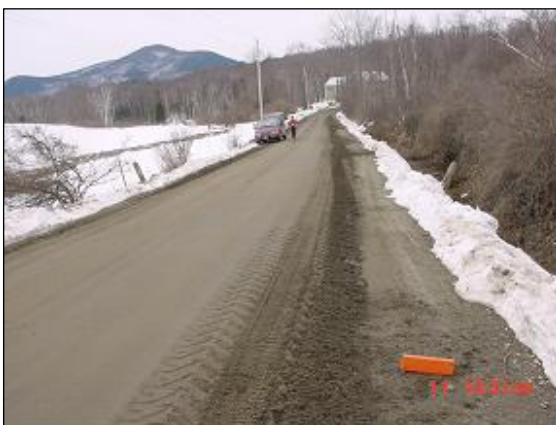
11 April 2003, Area 3, CE, image 2.



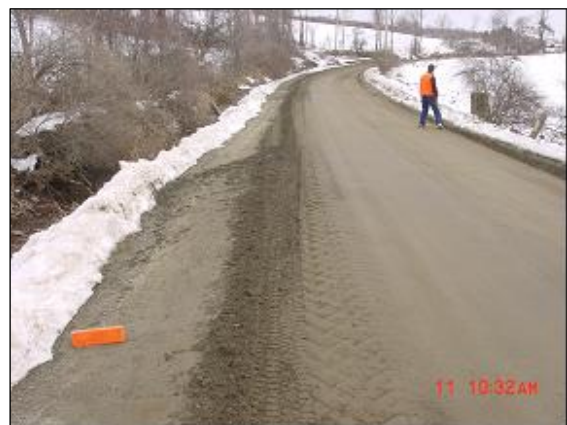
11 April 2003, Area 3, Cement, image 1.



11 April 2003, Area 3, Cement, image 2.



11 April 2003, Area 3, CM, image 1.



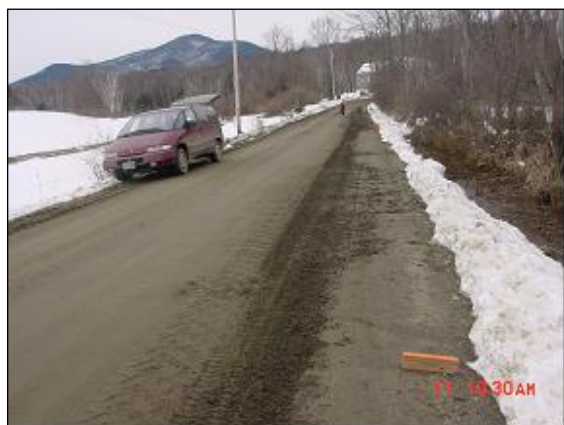
11 April 2003, Area 3, CM, image 2.



11 April 2003, Area 3, CW, image 1.



11 April 2003, Area 3, CW, image 2.



11 April 2003, Area 3, Geowrap, image 1.



11 April 2003, Area 3, Geowrap, image 2.

*B.3.4 Area 4*



25 February 2003, Area 4, CE, image 1.



25 February 2003, Area 4, CE, image 2.



25 February 2003, Area 4, CM, image 1.



17 March 2003, Area 4, CE, image 1.



17 March 2003, Area 4, CE, image 2.



17 March 2003, Area 4, CM, image 1.



17 March 2003, Area 4, CM, image 2.



17 March 2003, Area 4, CM, corrugations.



17 March 2003, Area 4, CW, image 1.



17 March 2003, Area 4, CW, image 2.



17 March 2003, Area 4, CW, image 3.



17 March 2003, Area 4, GCBD, image 1.



17 March 2003, Area 4, GCBD, image 2.



17 March 2003, Area 4, GCBW, corrugations.



17 March 2003, Area 4, Separator, image 1.



17 March 2003, Area 4, Separator, image 2.



19 March 2003, Area 4, image 1.



19 March 2003, Area 4, image 2.



19 March 2003, Area 4, image 3.



19 March 2003, Area 4, image 4.



19 March 2003, Area 4, image 5.



19 March 2003, Area 4, image 6.



21 March 2003, Area 4, CE, image 1.



21 March 2003, Area 4, CE, image 2.



21 March 2003, Area 4, CM, image 1.



21 March 2003, Area 4, CM, image 2.



21 March 2003, Area 4, CW, image 1.



21 March 2003, Area 4, CW, image 2.



21 March 2003, Area 4, GCBD, image 1.



21 March 2003, Area 4, GCBD, image 2.



21 March 2003, Area 4, Separator, image 1.



21 March 2003, Area 4, Separator, image 2.



24 March 2003, Area 4, CE, image 1.



24 March 2003, Area 4, CE, image 2.



24 March 2003, Area 4, Separator, image 1.



24 March 2003, Area 4, Separator, image 2.



24 March 2003, Area 4, CM, image 1.



24 March 2003, Area 4, CM, image 2.



24 March 2003, Area 4, GCBD, image 1.



24 March 2003, Area 4, GCBD, image 2.



24 March 2003, Area 4, GCBD, image 3.



24 March 2003, Area 4, CW, image 1.



24 March 2003, Area 4, CW, image 2.



26 March 2003, Area 4, image 1.



26 March 2003, Area 4, image 2.



8 April 2003, Area 4, CE, image 1.



8 April 2003, Area 4, CE, image 2.



8 April 2003, Area 4, CM, image 1.



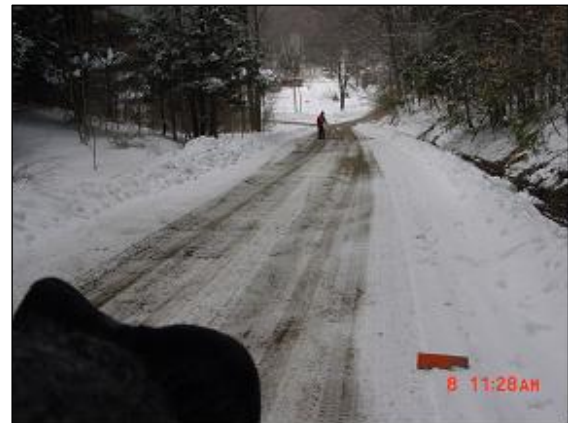
8 April 2003, Area 4, CM, image 2.



8 April 2003, Area 4, CW, image 1.



8 April 2003, Area 4, CW, image 2.



8 April 2003, Area 4, GCBD, image 1.



8 April 2003, Area 4, GCBD, image 2.



8 April 2003, Area 4, Separator, image 1.



8 April 2003, Area 4, Separator, image 2.



11 April 2003, Area 4, CE, image 1.



11 April 2003, Area 4, CE, image 2.



11 April 2003, Area 4, CM, image 1.



11 April 2003, Area 4, CM, image 2.



11 April 2003, Area 4, CW, image 1.



11 April 2003, Area 4, CW, image 2.



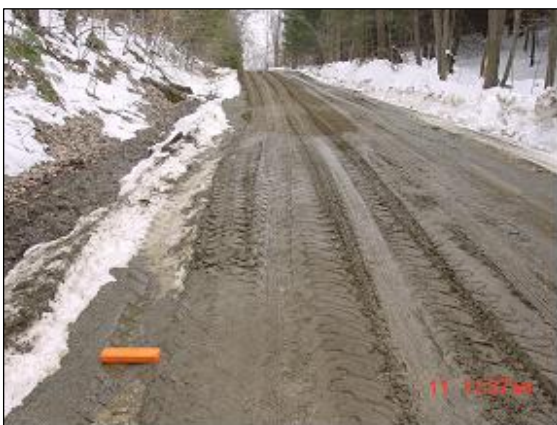
11 April 2003, Area 4, GCBD, image 1.



11 April 2003, Area 3, GCBD, image 2.



11 April 2003, Area 3, Separator, image 1.



11 April 2003, Area 3, Separator, image 2.



15 April 2003, Area 4, CE, image 1.



15 April 2003, Area 4, CE, image 2.



15 April 2003, Area 4, CM, image 1.



15 April 2003, Area 4, CM, image 2.



15 April 2003, Area 4, CW, image 1.



15 April 2003, Area 4, CW, image 2.



15 April 2003, Area 4, GCBD, image 1.



15 April 2003, Area 4, GCBD, image 2.



15 April 2003, Area 4, Separator, image 1.



15 April 2003, Area 4, Separator, image 2.

## **APPENDIX C: DYNAMIC CONE PENETROMETER MEASUREMENTS IN 2002 AND 2003, WINDSOR**

Appendix C is provided in compact disk format only, available from the first author. It contains excel files of dynamic cone penetrometer data collected from Windsor, Vermont. In addition, California Bearing Ratio estimates are calculated based on the following equation:

$$\text{CBR}(\%) = (292)/(\text{mm/blow})^{1.12}.$$

The nomenclature for the excel files is Day Month Year-Area-Test Section-location within the test section. For example, 29March02-1-CE-Mid, refers to the March 29, 2002, Area 1, Control East, in the middle of the test section. There are several additional files containing vertical CBR profiles or other charts of interest. These files are self-explanatory upon opening.

## APPENDIX D: SMRT PROBE DATA, 2003, WESTFORD

SMRT probe data were collected at Westford on several dates in 2003. The data collected showed a constant temperature with depth (from 2 to 24 in. of penetration), and we suspect that this is due to thermal inertia of the probe—the temperature of the probe was measured and not that of the soil. Slower penetrations would have been necessary to obtain accurate temperature profiles. Therefore, the temperature data are not presented. However, the penetration resistance, volumetric moisture content, and resistivity are thought to be accurate and are included. Note that the liquid water content only is indicated by the probe and that ice is excluded from that determination (i.e., low water content may indicate frozen soil). Frozen soil also has a relatively high electrical resistivity (e.g., above 600 ohm-m); however, the exact values depend greatly on soil composition and water content.

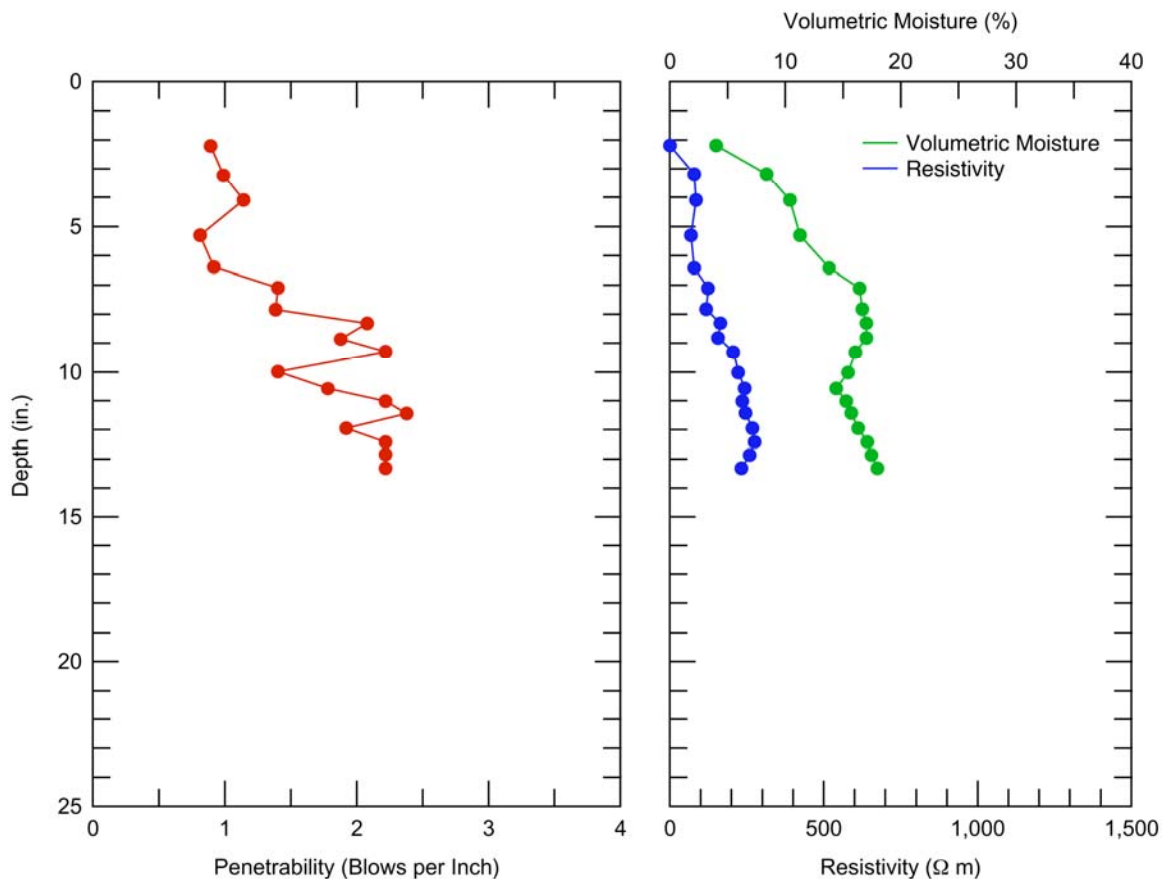


Figure D1. SMRT probe data, Control Section 2, March 19, 2003.

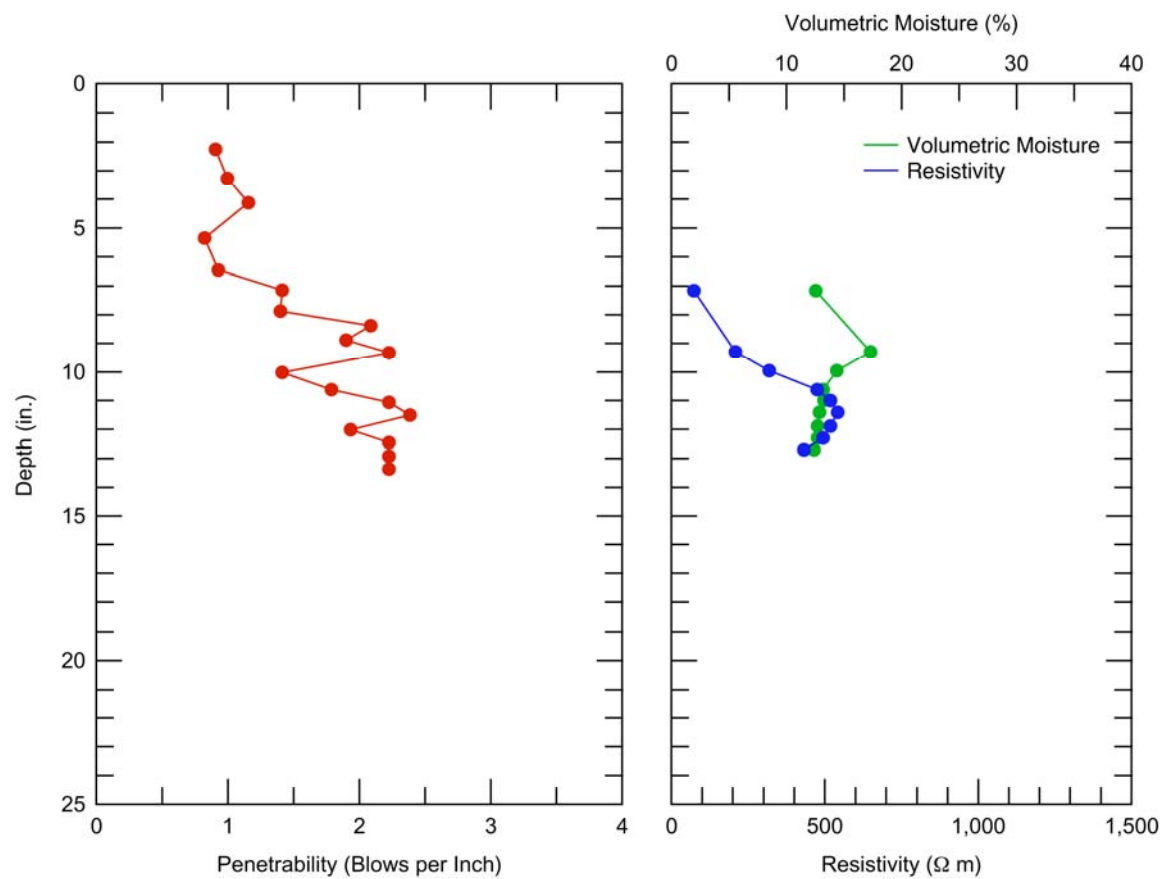


Figure D2. SMRT Probe data, Control Section 3, March 21, 2003.

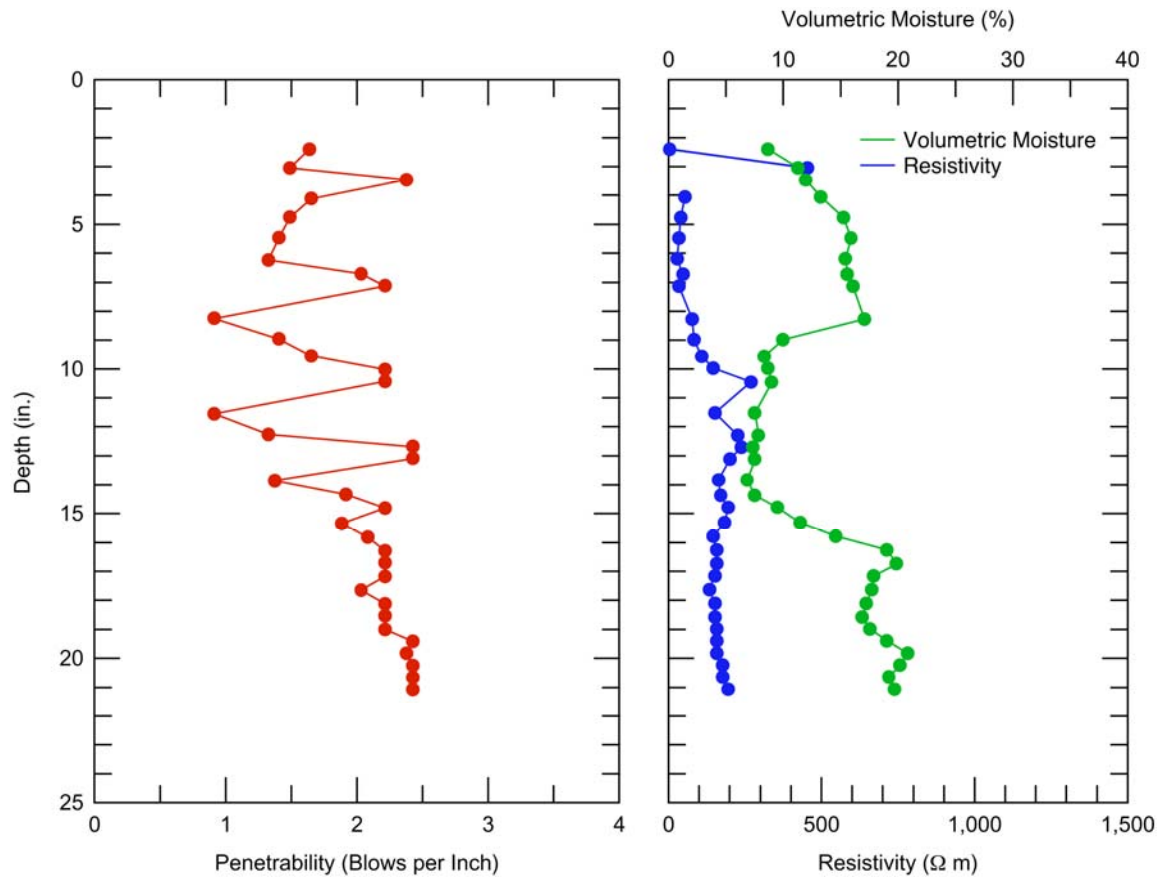


Figure D3. SMRT probe data, Geoweb 1S, March 28, 2003.

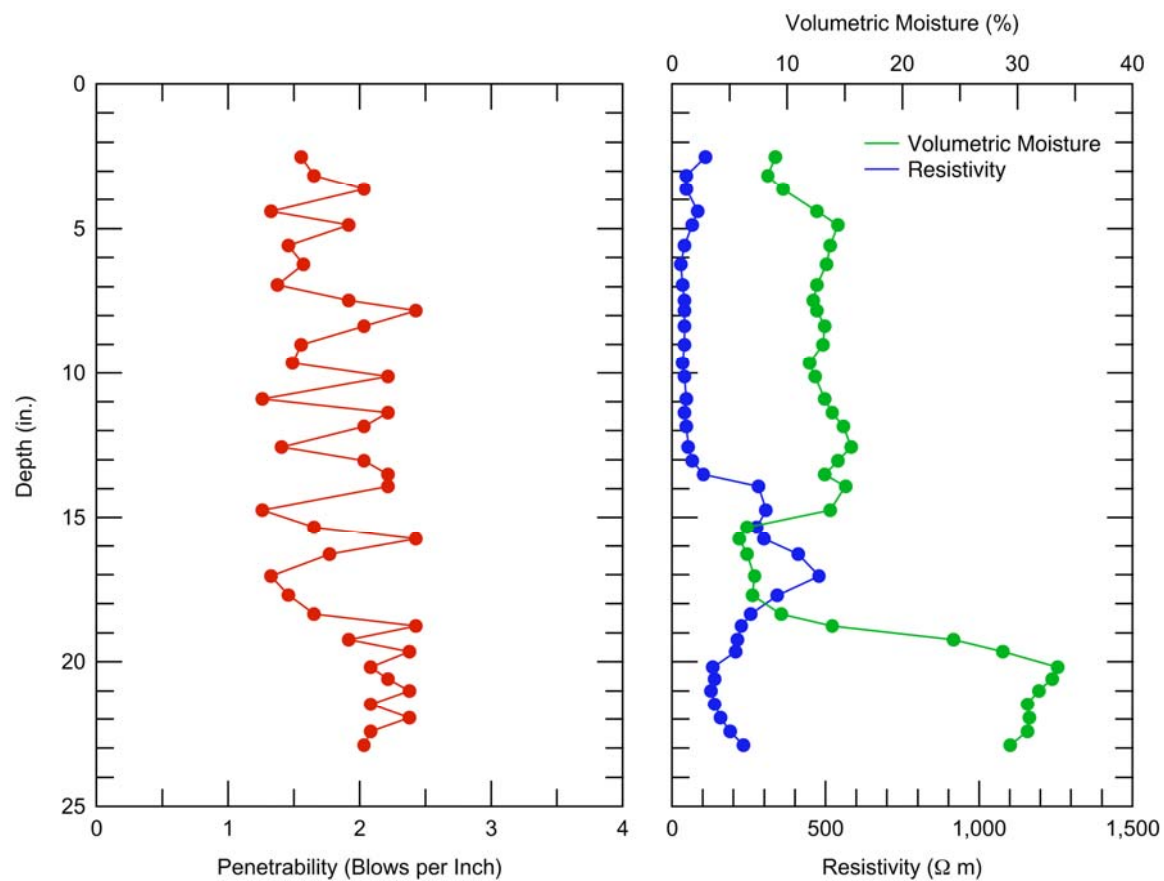


Figure D4. SMRT probe data, Geoweb 2S, March 28, 2003.

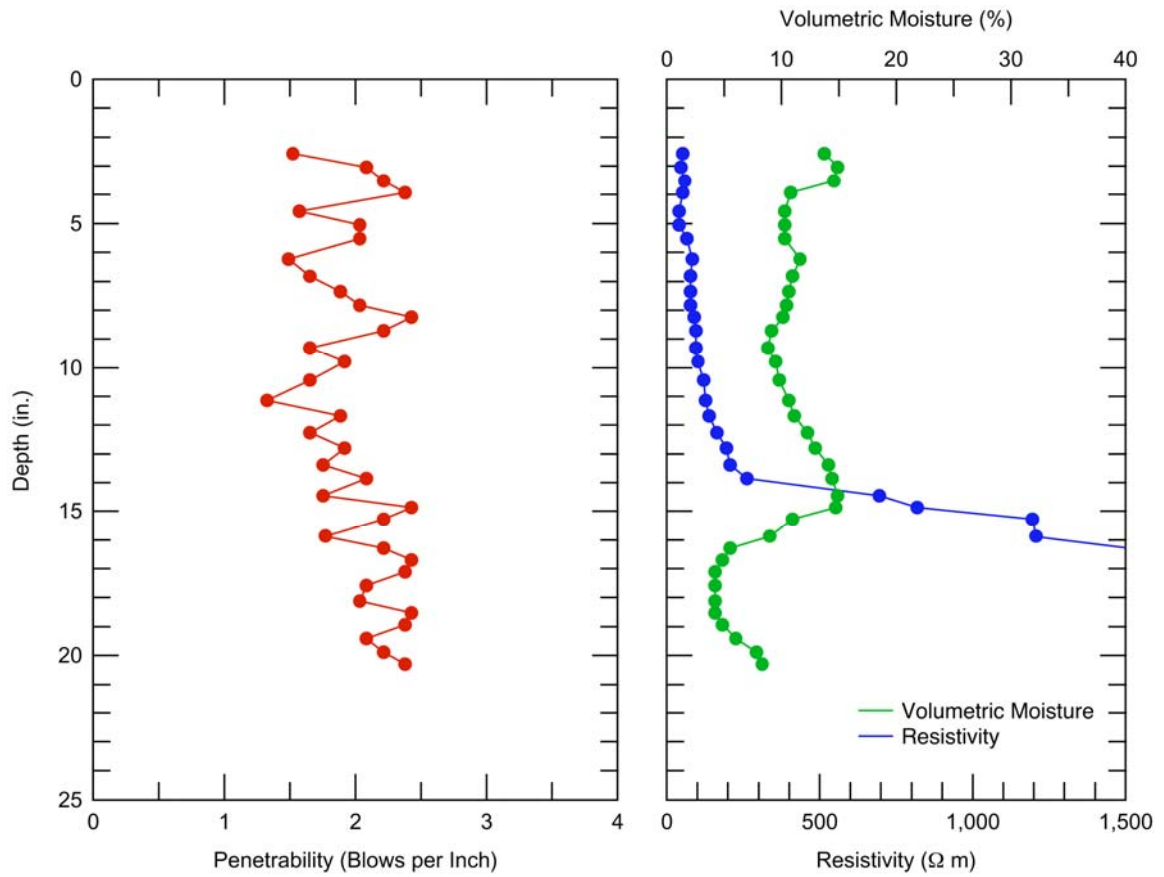


Figure D5. SMRT probe data, Geoweb 2S, April 8, 2003.

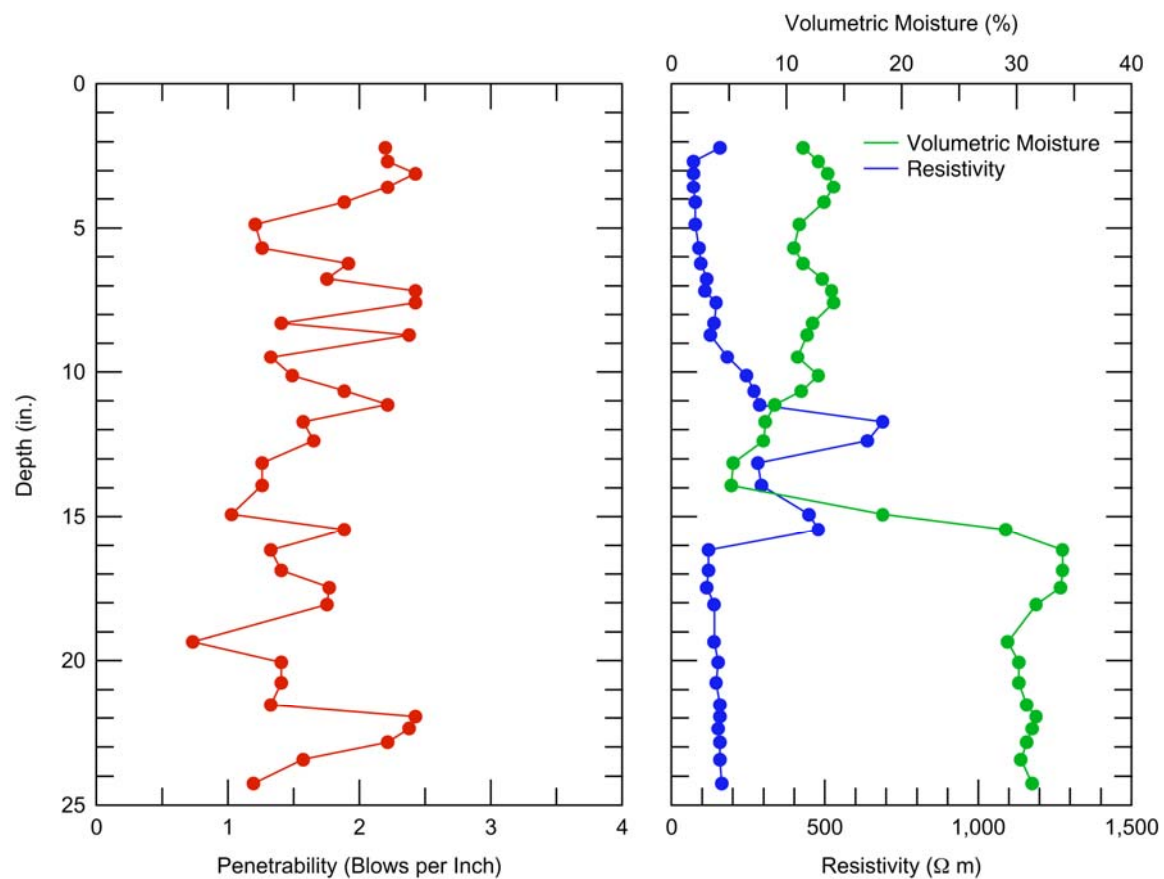


Figure D6. SMRT probe data, Geoweb 1N, April 15, 2003.

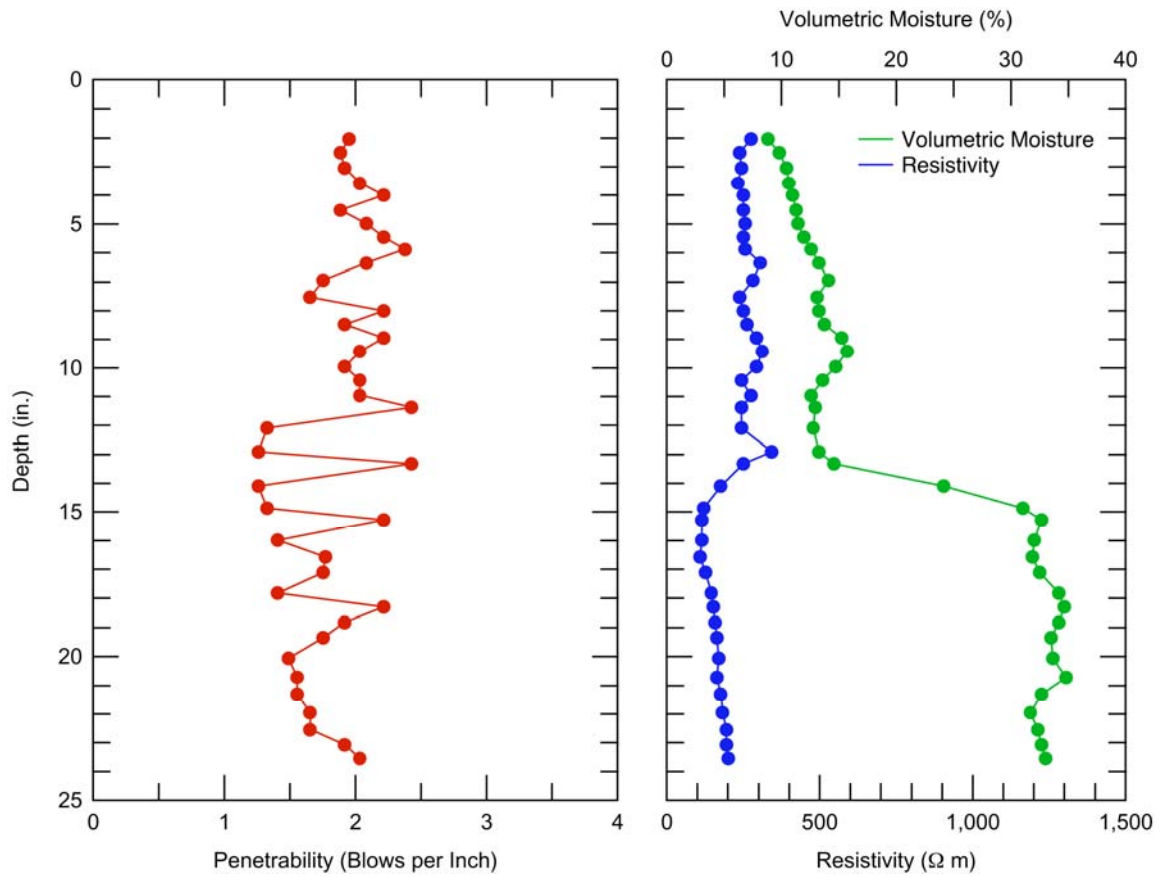


Figure D7. SMRT probe data, Geoweb 2N, April 15, 2003.

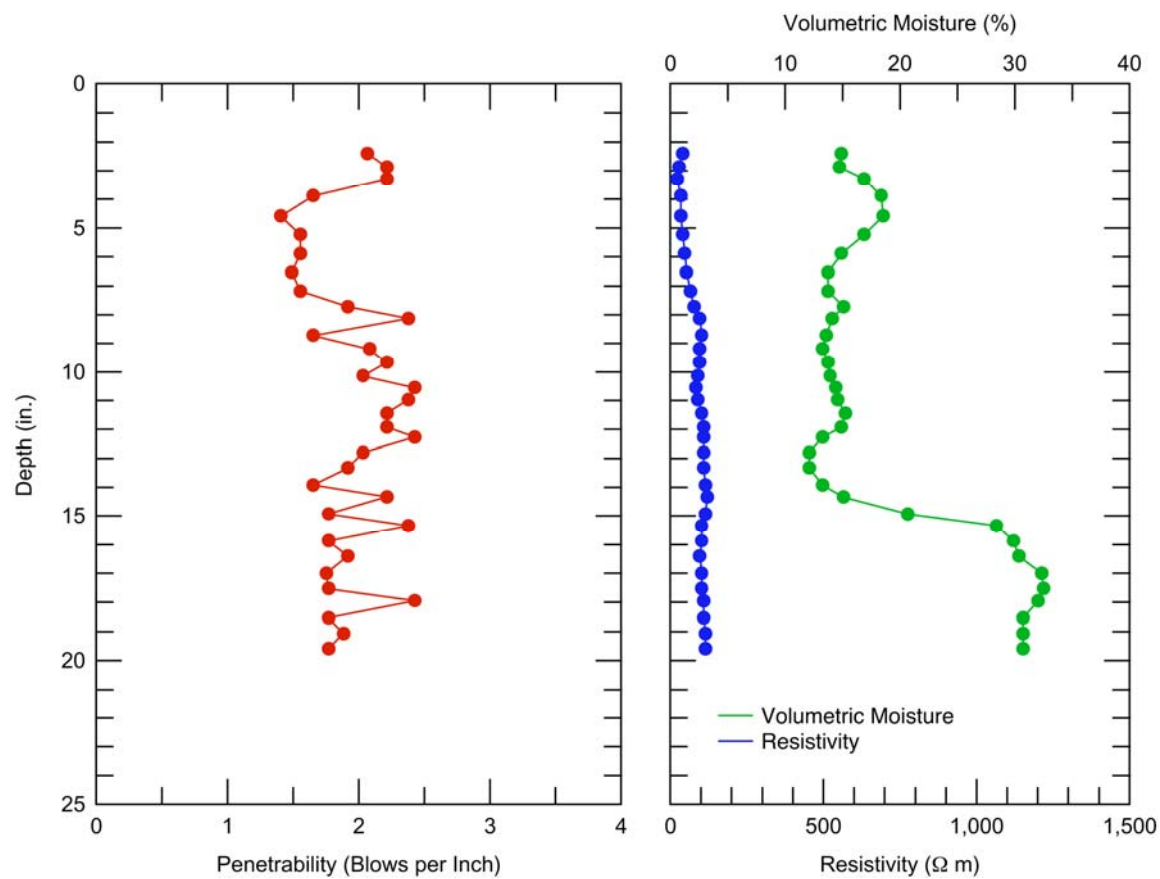


Figure D8. SMRT probe data, Geoweb 1S, April 15, 2003.

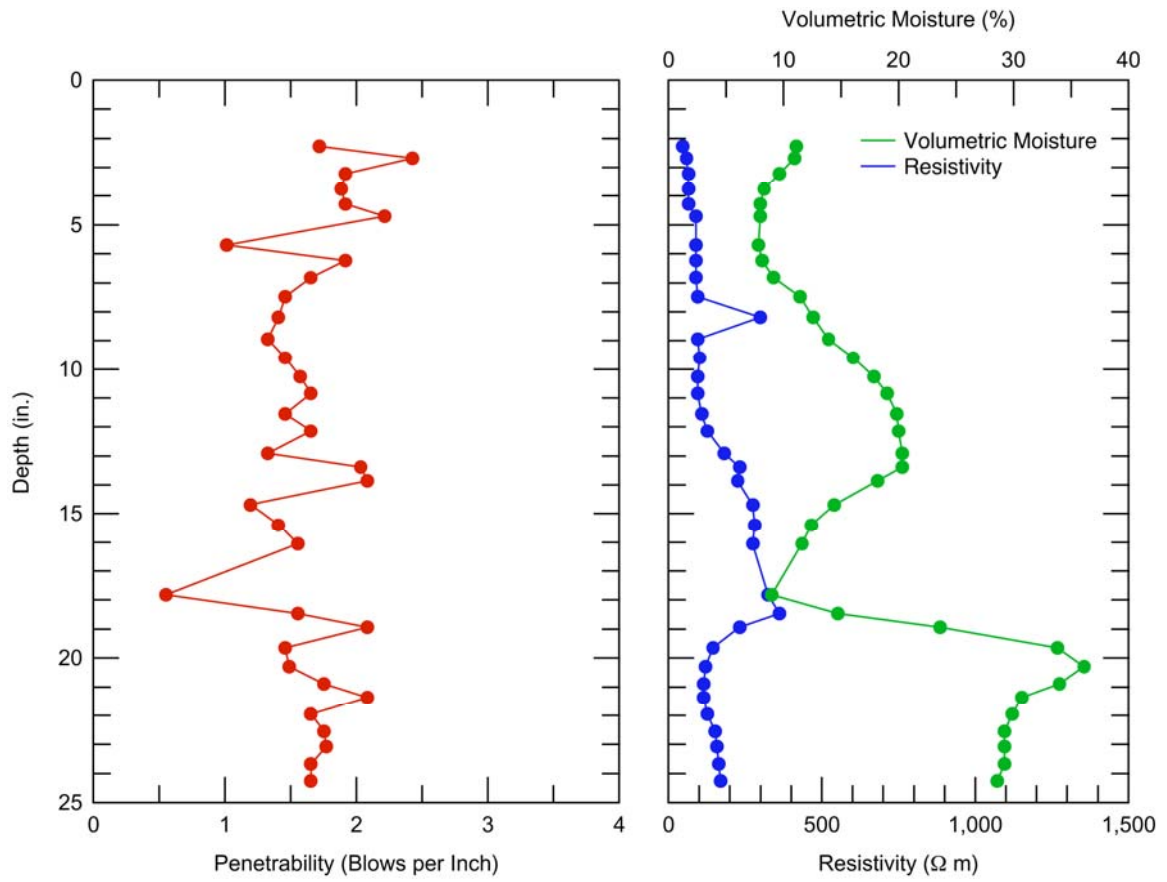


Figure D9. SMRTprobe data, Geoweb 2S, April 15, 2003.

# REPORT DOCUMENTATION PAGE

*Form Approved*  
*OMB No. 0704-0188*

Public reporting burden for this collection of information is estimated to average 1 hour per response, including the time for reviewing instructions, searching existing data sources, gathering and maintaining the data needed, and completing and reviewing this collection of information. Send comments regarding this burden estimate or any other aspect of this collection of information, including suggestions for reducing this burden to Department of Defense, Washington Headquarters Services, Directorate for Information Operations and Reports (0704-0188), 1215 Jefferson Davis Highway, Suite 1204, Arlington, VA 22202-4302. Respondents should be aware that notwithstanding any other provision of law, no person shall be subject to any penalty for failing to comply with a collection of information if it does not display a currently valid OMB control number. PLEASE DO NOT RETURN YOUR FORM TO THE ABOVE ADDRESS.

<b>1. REPORT DATE (DD-MM-YY)</b> February 2005		<b>2. REPORT TYPE</b> Technical Report		<b>3. DATES COVERED (From - To)</b>													
<b>4. TITLE AND SUBTITLE</b>  Improved Performance of Unpaved Roads During Spring Thaw				<b>5a. CONTRACT NUMBER</b>													
				<b>5b. GRANT NUMBER</b>													
				<b>5c. PROGRAM ELEMENT NUMBER</b>													
<b>6. AUTHOR(S)</b>  Karen S. Henry, James P. Olson, Stephen P. Farrington, and John Lens				<b>5d. PROJECT NUMBER</b>													
				<b>5e. TASK NUMBER</b>													
				<b>5f. WORK UNIT NUMBER</b>													
<b>7. PERFORMING ORGANIZATION NAME(S) AND ADDRESS(ES)</b>  U.S. Army Engineer Research and Development Center Cold Regions Research and Engineering Laboratory 72 Lyme Road Hanover, NH 03755-1290				<b>8. PERFORMING ORGANIZATION REPORT</b>  ERDC/CRREL TR-05-1													
<b>9. SPONSORING/MONITORING AGENCY NAME(S) AND ADDRESS(ES)</b>  Vermont Agency of Transportation and Federal Highway Administration				<b>10. SPONSOR / MONITOR'S ACRONYM(S)</b>													
				<b>11. SPONSOR / MONITOR'S REPORT NUMBER(S)</b>													
<b>12. DISTRIBUTION / AVAILABILITY STATEMENT</b>  Approved for public release; distribution is unlimited.  Available from NTIS, Springfield, Virginia 22161.																	
<b>13. SUPPLEMENTARY NOTES</b>																	
<b>14. ABSTRACT</b>  Unpaved roads in Vermont are subject to deterioration from seasonal freezing and thawing, and many towns have roads that suffer chronic serviceability problems during the so-called "spring thaw," or mud season. Several techniques thought to mitigate deterioration of unpaved roads during spring thaw were constructed on test sections of unpaved roads in two towns. Each potential remedy was aimed at providing some combination of limiting the availability of moisture in the winter, improving drainage during spring, and strengthening the upper portion of the road. Each technique used local and/or commercially available materials, and all were easy to construct, i.e., a town road crew could build them. For two spring thaw seasons, we compared strength estimates based on dynamic cone penetrometer tests and the percentage of the road surface rutted for treated and control sections. Methods that permanently improved the strength of the top 12 inches of the road or decreased the water content of the upper 12 inches of the road resulted in significant performance improvement during spring thaw. Cement and cellular confinement systems worked well by improving the strength of the upper layers of the soil. Two new techniques—geowrap, comprising clean sand sandwiched by geotextile separators placed 12–18 inches deep, and the patented Geosynthetic Capillary Barrier Drain—provided benefit by keeping the upper layers of the soil relatively dry. Geogrid and geotextile separators placed 12 inch deep and trench drains parallel to the road provided no observable benefit.																	
<b>15. SUBJECT TERMS</b> <table style="width: 100%; border: none;"> <tr> <td style="width: 25%;">Cellular confinement</td> <td style="width: 25%;">Geogrid</td> <td style="width: 25%;">Geowrap</td> <td style="width: 25%;">Trench drain</td> </tr> <tr> <td>Cement stabilization</td> <td>Geosynthetic capillary barrier drain</td> <td>Mud season</td> <td>Unpaved roads</td> </tr> <tr> <td>Frost heave</td> <td>Geotextile</td> <td>Thaw weakening</td> <td></td> </tr> </table>						Cellular confinement	Geogrid	Geowrap	Trench drain	Cement stabilization	Geosynthetic capillary barrier drain	Mud season	Unpaved roads	Frost heave	Geotextile	Thaw weakening	
Cellular confinement	Geogrid	Geowrap	Trench drain														
Cement stabilization	Geosynthetic capillary barrier drain	Mud season	Unpaved roads														
Frost heave	Geotextile	Thaw weakening															
<b>16. SECURITY CLASSIFICATION OF:</b>			<b>17. LIMITATION OF OF ABSTRACT</b>	<b>18. NUMBER OF PAGES</b>	<b>19a. NAME OF RESPONSIBLE PERSON</b>												
<b>a. REPORT</b>	<b>b. ABSTRACT</b>	<b>c. THIS PAGE</b>	U	179	<b>19b. TELEPHONE NUMBER (include area code)</b>												
U	U	U															