

Night Vision Goggle Cockpit Integration

Mike Sedillo, MSgt, USAF
Air Force Research Laboratory
AFRL/HECV
2255 H Street, Bld. 248
Wright-Patterson AFB, OH 45431
(937) 255-8762

ABSTRACT

Integrating NVGs into aircraft with incompatible interior designs limits performance and presents safety and operational concerns to the flying communities. Non-ejection safe NVGs and their corresponding carrying case presents a space dilemma forcing pilots to contend with where to safely store the goggles. An example of this occurred when the carrying strap entangled the flight controls of an A-10. Interior aircraft lighting not compatible with the spectral sensitivity of NVGs presents another concern. The prohibitive cost of aircraft modifications has resulted in the application of frequent "quick-fix" solutions. An effective lighting-fix was implemented in the cockpit of the B-1 bomber, but the problem persisted due to non-modified lighting from the aft stations. Aircraft System Program Office's (SPO), attempted to solve this problem by proposing the installation of a light-blocking curtain, separating the two compartments. Fabric samples for the proposed curtain were evaluated to determine the fabric which met the criteria. In the interest of reducing weight and maximizing battery life, NVG manufacturers and field units for the most part, have transitioned from alkaline to lithium batteries. However, with the use of lithium comes environmental, cost, and shipping concerns. The results of a comparative study on various batteries will be presented.

INTRODUCTION

B-1 Curtain

Night vision goggle performance is improving with advances in many areas. Unfortunately, the warfighter can not always capitalize on these improvements due to some cockpit design limitations. Fabric qualities within the cockpits are not always considered prior to introducing NVG's to new weapon systems. Fabrics with high-sheen characteristics reflect excess light causing glare, bloom, and system gain reduction in the NVG's.

An effort to improve the lighting in the B-1 was initiated at the B-1 SPO, Wright-Patterson AFB. Incompatible lighting in the front cockpit was corrected with the addition of a "Christmas Tree" lighting modification. This relatively inexpensive modification involves the installation of a string of NVG-compatible lights around the flight instruments, similar to those used to decorate a tree. These lights enable the crew to look under the NVG's to observe their instruments with their naked eyes without the light effecting the NVG's performance. However, since the Offensive and Defensive System Officers ("Back-seaters) don't require NVG's, lighting modifications were not made to their stations, leaving full spectrum lighting in the aft compartments.

This created problems with incompatible light flooding into the forward flight station degrading the NVG's performance. When exposed to excessive light, the NVG's auto-gain feature activates reducing the level of light intensification as a means of protecting the system from over light saturation. The gain reduction results in a general reduction of goggle performance and corresponding reduction visual acuity to the user.

A means to stop the transition of light from the back to the forward area was needed. A prototype curtain was locally fabricated at Ellsworth AFB, using a heavy black nylon fabric as a first attempt to stop the "bad" light. They selected a black fabric, as it was perceived to have low reflectivity. The curtain was installed in the hallway between the fore and aft flight-stations, and then evaluated on the ground for form and function. When viewed through NVGs, the curtain appeared to "glow" from the transmission of non-compatible lighting through the weave of the fabric. A non-porous material was needed to stop the light's transmission. The evaluators improvised and modified the curtain by attaching material from a 35mm projector screen onto the back of the nylon curtain. Although this modification successfully blocked the transmission of light when viewed through NVGs, the resulting curtain was very bulky. Concerns of reflectivity

Report Documentation Page

*Form Approved
OMB No. 0704-0188*

Public reporting burden for the collection of information is estimated to average 1 hour per response, including the time for reviewing instructions, searching existing data sources, gathering and maintaining the data needed, and completing and reviewing the collection of information. Send comments regarding this burden estimate or any other aspect of this collection of information, including suggestions for reducing this burden, to Washington Headquarters Services, Directorate for Information Operations and Reports, 1215 Jefferson Davis Highway, Suite 1204, Arlington VA 22202-4302. Respondents should be aware that notwithstanding any other provision of law, no person shall be subject to a penalty for failing to comply with a collection of information if it does not display a currently valid OMB control number.

1. REPORT DATE 09 OCT 2000	2. REPORT TYPE N/A	3. DATES COVERED -			
4. TITLE AND SUBTITLE Night Vision Goggle Cockpit Integration		5a. CONTRACT NUMBER			
		5b. GRANT NUMBER			
		5c. PROGRAM ELEMENT NUMBER			
6. AUTHOR(S)		5d. PROJECT NUMBER			
		5e. TASK NUMBER			
		5f. WORK UNIT NUMBER			
7. PERFORMING ORGANIZATION NAME(S) AND ADDRESS(ES) Air Force Research Laboratory Wright-Patterson AFB, OH 45433		8. PERFORMING ORGANIZATION REPORT NUMBER			
9. SPONSORING/MONITORING AGENCY NAME(S) AND ADDRESS(ES)		10. SPONSOR/MONITOR'S ACRONYM(S)			
		11. SPONSOR/MONITOR'S REPORT NUMBER(S)			
12. DISTRIBUTION/AVAILABILITY STATEMENT Approved for public release, distribution unlimited					
13. SUPPLEMENTARY NOTES The original document contains color images.					
14. ABSTRACT					
15. SUBJECT TERMS					
16. SECURITY CLASSIFICATION OF:			17. LIMITATION OF ABSTRACT UU	18. NUMBER OF PAGES 6	19a. NAME OF RESPONSIBLE PERSON
a. REPORT unclassified	b. ABSTRACT unclassified	c. THIS PAGE unclassified			

and general safety surfaced, so the prototype curtain was sent to the Air Force Research Laboratory for spectral evaluation. The materials were immediately recognized as unsuitable for the typical military flight environment. The flammability of the nylon was the first concern and although the characteristics of the projector screen material were unknown, the safety and availability of the material would likely be questionable for general application in fielding the design for general application.

Sample Selection

Efforts to find replacement materials began immediately. Materials had to have low reflectivity and low or zero light transmission. The materials also needed to be fire resistant for use in flight environments.

The samples identified in Table-1 were selected for evaluation. Several of the samples, such as the flight clothing and B-52 material, were materials already approved for use in flight environments. The other samples were selected based on the known flame resistant qualities of both Nomex™ and fiberglass. Flight clothing items were selected for evaluation since the use of these materials had already been established. Evaluating the flight clothing would also provide a baseline of reflectance levels already tolerated in the cockpits.

SAMPLE #	Description
1	Teflon-Coated Fiberglass (55-5)
2	Teflon-Coated Fiberglass (55-10)
3	Mylar Sandwich
4	Rubber-coated Cotton (two-sides)
5	Flat-Black Rubberized
6	Proto-type (Nylon/screen)
7	NOMEX-Black
8	NOMEX-Sage green
9	TCTO Curtain (Urinal)
10	B-52 Curtain-Cotton (un-coated)
11	B-52 Curtain-Cotton (rubber coated)
12	Green Flight Jacket (CWU-36/P)
13	Teflon-Coated Nomex (63-10)

Table 1. Subject Samples

Set-up & Testing-Transmission

The samples were measured for both light transmission and spectral reflection using the following methods. During transmission evaluation, a Hoffman ANV-120 integrating sphere provided a calibrated light source for transmitting light through the subject materials. Any light transmitted was captured and intensified using an NVG (model AN/AVS-9) on the other side of the subject

material. A luminance probe measured the goggles output luminance before and after the subject material was inserted in the light path between the light sphere and the NVG. Light transmitted through the fabric would be a percentage of the light originally measured in the sphere.

The NVG’S were focused to infinity and eyepiece lenses set at zero-diopter using the Hoffman ANV-126. The goggles were then centered on the sphere’s output port. After a brief NVG warm-up, the luminance in the sphere was adjusted (1.980×10^{-3} Foot-Lamberts). A reference reading was recorded before measuring the samples by placing the luminance probe in the center of the sphere’s output. The sample-reading would later be divided by this reference- readings to determine the percentage of light transmitted. Eight samples met the ideal “zero light transmission” goal as illustrated in Table 2. Interestingly, the privacy curtain already in use in the B-1 transmitted the most light at 51%.

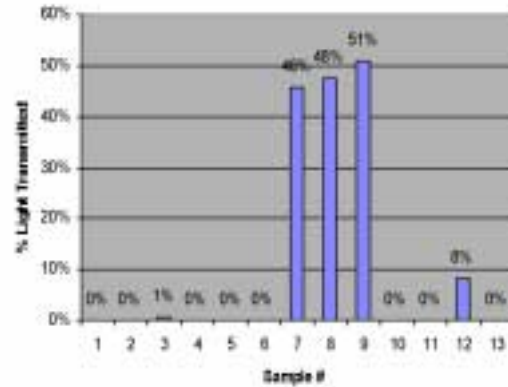

Table 2. Transmission

Set-up & Testing-Spectral Reflectance

Assessing the spectral reflectance qualities of the fabrics involved bouncing a 2856K light source off the subject materials and measuring the reflected light using a spectroradiometer. A reference reading of the light source was directly measured to calculate the percentage of light reflected. This would provide the “spectral” reflectance of the material samples.

We placed the 2856K light source at a 90° angle to the sample surface and parallel to the original reference measurement axis. The spectroradiometer was positioned 45° off the original measurement axis.

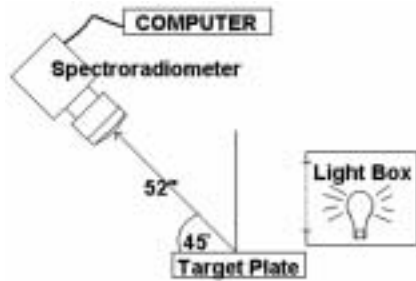

Figure 1. Measuring Spectral Reflectance

The spectroradiometer's lens was positioned 52 inches from the target and centered on the target area. The length would adjust for the focal length of the spectroradiometer. After a 15-minute warm up for the light source, the samples were positioned flat against the target plate and individually scanned and recorded on a laptop computer. The 2856k light source was then placed in the sample location and centered in the field of measure for the spectroradiometer. A scan of the light source was taken from the same 45° off axis target plate location. This reading would serve as the base line for division of the sample scans giving us the spectral reflectance qualities of the materials. See Table 3 for results.

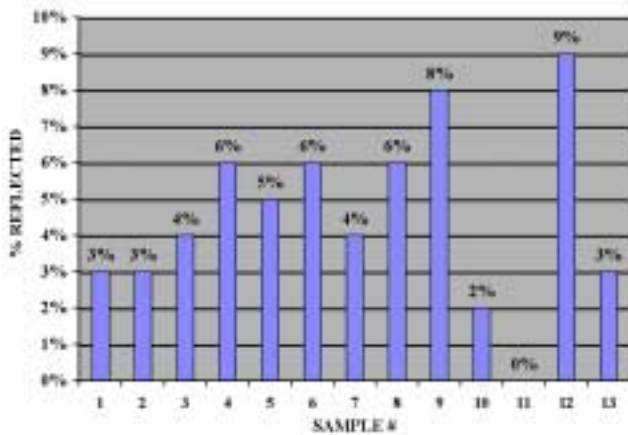

Table 3. Spectral Reflection Results

The Teflon™-coated fiberglass and Nomex™ materials (samples 1, 2 & 13) performed well exhibiting relatively low (3%) reflectance and zero transmission. Just as important, both qualities were achieved with a single fabric-layer design as opposed to Sample 11, which was the two-layer bulky B-52 curtain. Sample 5 performed well with zero-reflectance, but lacked the necessary flame protection qualities. The original curtain (sample #6), performed well in the transmission tests, but fared relatively poorly when assessed for reflection. It's bulkiness and flammability did not help its case either.

Sample #4 did well in the tests, but was not selected due to flammability concerns.

The manufacture of the Teflon-coated materials, CS Hyde Company, boasts flame resistant qualities in the fiberglass samples, but these fabrics tended to be less pliable with a tendency to crease when folded. This would likely effect the long-term durability of the curtains. We selected the Nomex™ fabric because of its pliability, flame resistant qualities and from its prior approval and reputation for use in flight environments.

CS Hyde fabricated a proto-type curtain using the Teflon-coated Nomex™. The curtain was evaluated for form and function on the B-1 bombers at Ellsworth AFB, ND with highly positive results. If approved for use, the entire B-1 bomber fleet will likely receive copies of these new light-blocking curtains.

This study was successful in discovering a new lightweight fabric for inexpensively modifying the B-1 bombers for NVG operations. Additionally, the B-52 bomber fleet and other airframes could benefit by adopting this new curtain for similar applications.

Powering NVG's

Field units have loudly expressed their disdain for products powered by lithium or "exotic" batteries. They're justifiably concerned about the availability of special purpose batteries that may not be available when tasked for short notice deployments. The preference is for batteries that are available at any "grocery store" worldwide.

Lithium batteries pose many logistical problems for supervisors in the field. Storage, disposal and transportation of these hazardous items increases the supervisors workload and budget requirements. With reduced manpower levels across the DOD, supervisors are adamant about minimizing procedures for common tasks. Having to dispose of environmentally hazardous lithium batteries is an arduous task they would prefer to eliminate. Additionally, shipping these items during deployments dramatically increases the paperwork and stress prior to deployments. Are there performance benefits of lithium batteries that justify contending with the concerns cited above?

A two-fold study was conducted to both compare lithium and alkaline batteries and to base line the battery consumption rates of the four-tube (image intensifier) Panoramic Night Vision Goggle (PNVG) system. We anticipate the requirement of this data during final critical

design and logistical decisions for the new Integrated PNVG (I-PNVG) system, currently in development.

During the test, we compared the 3.6V AA-size lithium and AAA-size alkaline batteries for endurance under maximum current draw conditions for the four-tube PNVG systems. The 3.6 volt lithium battery is the same battery currently used to power the goggles in the field. The "Banana" mount must have extender caps installed prior to using this AA full-sized battery. We also ran a test with a two-tube, AN/AVS-9 (F4949) NVG for comparison.

EQUIPMENT:

- 7101B Hewlett-Packard strip chart recorder
- 1980A Pritchard™ photometer S/N C-512
- VARIAC Voltage Control
- 4-Watt light bulb w/ holder
- Lab jack
- Foam core lined box 21" h x 20" w x 19" d
- SAFT™ Battery, Lithium 3.6V (AA-size)
- Kodak™ Battery, 1.5 (AAA-size)
- Energizer™ Battery, 1.5 (AAA-size)
- PNVG II, Configuration 4, S/N 0001
- PNVG I, Configuration 2, S/N 0002
- F4949D, S/N 3873

We lined a box with white foam core to provide a relatively even luminance into the goggles objective lenses. The box was placed on its side on an optical table and a lab jack placed six inches into the box. The jack would be used to elevate the goggles into the center of the box opening. A foam core baffle was then placed in front of the lab jack to reflect light back into the box cavity. We then centered a 4-watt light within the box, in front of the baffle and plugged the light into a variable power controller. The lab jack was raised to center the goggles within the box opening.. (See Figure 2)

Once initial set-up was accomplished, we calibrated the photometer and placed the detector head perpendicular to the opening of the box approximately one meter from the box opening. This would allow sufficient distance to focus the detector onto the output of the subject NVG.

We selected the 20-minute measuring aperture and a (10:1) scale for low magnification and a strip-chart recorder was attached to the photometer to record the luminance levels. We checked the scale on the recorder and zeroed it to the output of the photometer and set the strip chart recorder to 10V and 1 in/hour scale as a compromise between sensitivity and readability.

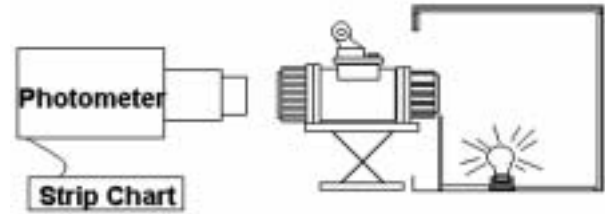

Figure 2. Battery Consumption Test

The goggles were positioned onto the lab jack and the photometer was focused onto the output of the left channel of the F4949 goggles, and the left-central channel of the four-channel PNVG's. We adjusted the 20-minute aperture of the photometer's detector to be overfilled by 2/3 to maximize luminance input. With the basic test set-up accomplished, we turned out the lights and started the strip chart recorder. The photometer measurement aperture was opened and the goggle battery pack switched "ON".

The variable power controller for the 4-watt light bulb was "zeroed" then switched "ON". While watching the luminance level on the photometer, we slowly increased the light bulb's intensity. The intensity was carefully adjusted until the goggles out-put leveled off, indicating activation of the goggles' protective gated power supply system. We then reduced the goggle output by 10% by reducing power to the 4-watt bulb.

Once initiated, we monitored the test hourly. The batteries all supplied consistent power as indicated by the level luminance readings on the strip charts. We concluded the tests when the readings on the strip chart "nosed over" indicating a drop in goggle output luminance caused from a lack of sufficient current to the image intensifiers. At the conclusion of the tests, the photometer's aperture was closed and all associated equipment was shut down.

Two unusual observations were noted during the tests. The first was an asymmetric luminance degradation of the optical channels towards the end of the battery life when testing the four-tube PNVG systems. The output of the left out-board channel was noticeably brighter than the adjacent optical channels. The luminance levels degraded from right to left with the right most channel being the most dim.

Another interesting characteristic we noted was a high rate of flashing in all optical channels when the PNVG I's with AAA batteries reached approximately 1.97 vdc. The

image intensifiers began an on/off oscillation at a rate similar to the flash rate of the low battery indicator.

The four-tube PNVG's with the AA Lithium batteries averaged 7.45 hours while the other four-tube PNVG version averaged 11.18 hours using the AAA alkaline batteries. Both battery types would provide sufficient energy to power either a two-tube or four-tube NVG system on a typical 4-5 hour mission. The F4949's performed exceptionally well with both the Lithium and the alkaline batteries. AA Alkaline batteries provided an average of 16.5 hours of life, while the Lithium's lasted an average of 31 hours.

Using the aircraft's power to energize helmet-mounted accessories would be ideal for both the user and the maintainers. For the maintainers, a ship-side power supply would reduce the logistical footprint during deployments. However, maximum commonality in aircraft and man-side components must be stressed.

However, until a common power supply cord is available for these man-mounted items, system designers will likely continue to rely on batteries to supply the power. This study was successful in demonstrating that the IPNVG power consumption could be satisfied with either Lithium or the preferred Alkaline batteries.

NVG In-flight Storage

Storing NVG' in a fighter cockpit poses serious concerns. Currently, NVGs are removed during critical phases of flight to include landings and take-offs. When removed, today's goggles are placed in their storage case, which typically is the size of a lunch box. When the carry strap of one of these cases became entangled in the flight controls of an A-10 attack jet, the immediate removal of the straps was ordered Air Force wide. However, the issue of storing the case in the jet remains. With the tight confines of today's modern fighter aircraft, there's hardly room for any additional items. The ideal solution would be to simply eliminate the need to remove and store the NVG's. The helmet-mounted Integrated Panoramic Night Vision Goggle (I-PNVG) will solve this as it will remain attached to the pilot's helmet during all phases of flight. They will have the capability to be removed from the pilots' field of view by simply rotating them to an up and stowed position, but will drop down during ejection to provide wind blast protection. (see Figure 3)

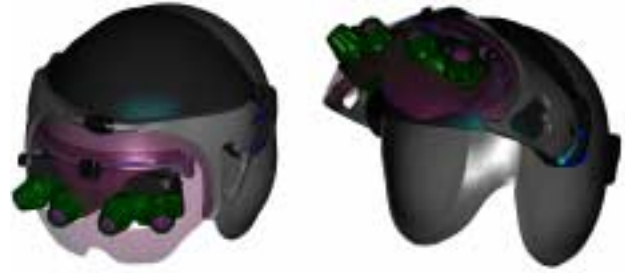

Figure 3. Integrated PNVG

However, until these goggles are fielded, an interim solution to safely stow the today's goggles needs to be devised. An early attempt to solve this problem was initiated by designing an NVG storage bracket for attachment to the inside of the cockpit wall. The goal was to find a design solution that would not require aircraft modifications, would be inexpensive to produce, and could integrate in a maximum number of airframes.

The first bracket design utilized an ANVIS-style NVG helmet mount that allowed the NVG's to easily click in and out of the bracket. The intent of this design approach was to use the unoccupied oxygen regulator storage bracket as a mounting point. Since the actual oxygen regulator would be attached to the pilot's torso harness in-flight, the regulator *storage* bracket would be available for use during flight to mount an NVG storage bracket. (see Figure 4)

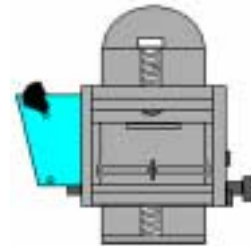

Figure 4. Initial NVG Cockpit Mount-Version I

However, during field evaluation we discovered a couple of problems with this design. The pilots we interviewed explained that the wall-mounted regulator brackets were seldom in serviceable condition due to their flimsy mounting points. In the F-16, the bracket is attached to a thin sheet of a plastic-like material. This caused the NVG storage bracket to wobble during use. The bracket moved during installation and removal making it unstable to use.

Additionally, the position of the wall bracket posed some possible spatial disorientation issues. Since the bracket was positioned on the lower right wall behind the ejection seat, the pilots would have to turn their heads down and to

the right during storage and removal of the NVGs. Placing the head at these axis, particularly at night could cause the pilots to experience some levels of spatial disorientation.

The pilots recommended we alter our design to mount the bracket on the canopy's hand rail, or what they referred to as the "towel rack." The hand rails are used to manually lift the canopy open during an emergency ground egress. The right-side hand rail is used to stow a portable floodlight. When not flying, the floodlight is attached to the right lower panel, but during night flights, is brought forward and attached to the rail via a small, adjustable clamp. We redesigned our NVG storage bracket to mount to the same style clamp as is used with the floodlight. (See Figure 5)

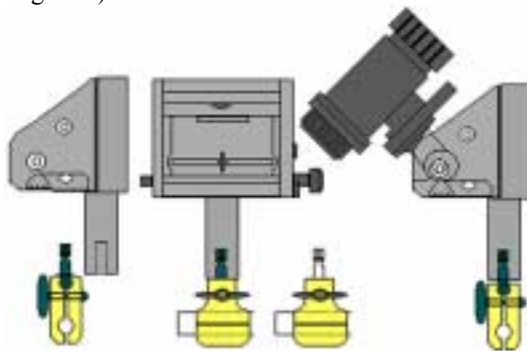

Figure 5. NVG Cockpit Mount-Version II



Figure 6. Actual Prototype Mount

The design is simple and inexpensive to produce. We sent the newly designed mount to the 113th F-16 Fighter Squadron in Terra Haute Indiana for further assessment and are awaiting feedback to finalize the design. If the design proves worthy of implementation, flight safety in the fighters could be improved with the removal of the NVG storage case. Pilots will be able to safely store their NVG's without having to fumble for storage cases, and the storage cases will no longer pose threats as loose

objects within the cockpit. This improved design should also minimize spatial disorientation events by allowing the pilots to store their NVG's without having to turn their heads.

CONCLUSION

Consideration to all aspects of cockpit interiors is essential before introducing new technologies. When selecting power sources for these technologies, logistical support issues must be weighed heavily on how they will impact long-term costs, manning and taskings at the gaining support units. Future NVG designs (I-PNVG) are encouraging and will dramatically enhance overall flyer safety by eliminating the need to store NVG's in the cockpit. Involving both the users and maintainers early in the design process will help minimize or eliminate the need for expensive retro-modifications.

ACKNOWLEDGEMENTS

Sincere thanks to Mr. David Sivert, Ms. Sharon Dixon and Mr. Ed Asper of Sytronics Inc., who were instrumental in collecting and processing data for these projects.

REFERENCES

1. B-1 Night Vision Enhancement Project (AL/CF Tech Report 1994 #184)
2. U.S. Air Force Technical Order 12S10-2AVS9-1 Image Intensifier Set, Type AN/AVS-9 (V)
3. Electro-Optical Surveillance, Vol III, CCS Security Source Library, Adcock

BIOGRAPHY

MSgt Mike Sedillo is the Superintendent, Visual Display System's Branch at the Air Force Research Laboratory. He maintained NVG systems for ten years and helped write two NVG technical orders and several Life Support-related manuals. He spent 5 years teaching NVG maintenance as the senior military instructor at the Aircrew Life Support technical school. He has a BS in Education and recently received an associates degree in Aircrew Life Support Technologies. MSgt Sedillo is currently engaged with the joint Integrated Panoramic Night Vision Goggles program.