



INERTIAL HEAD TRACKING FOR 3D AUDIO (PROJECT "SOUND ADVICE")

A
F
F
T
C

Capt Jacque M. Joffrion
Project Manager/Test Pilot

Capt Frank A. Delsing
Project Test Pilot

Capt Christopher E. Hamilton
Project Flight Test Engineer

Capt Michael D. Presnar
Project Flight Test Engineer

Capt John R. Shinoskie
Project Flight Test Navigator

Sqn Ldr Stuart M. Reed
Project Test Pilot

DECEMBER 2004

FINAL TECHNICAL INFORMATION MEMORANDUM

Approved for public release; distribution is unlimited.

This Technical Information Memorandum (AFFTC-TIM-04-06, Inertial Head Tracking for 3D Audio, Project "Sound Advice") was prepared and submitted under Job Order Number M04C0400 by the Sound Advice test team.

Prepared by:

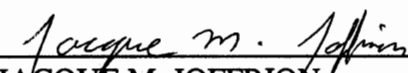

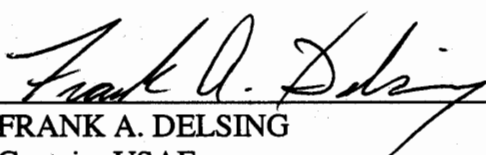
JACQUE M. JOFFRION
Captain, USAF
Project Manager and Test Pilot

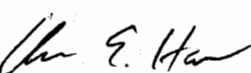
FRANK A. DELSING
Captain, USAF
Project Test Pilot

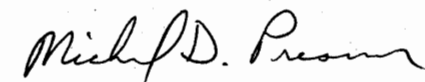

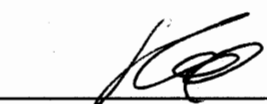
CHRISTOPHER E. HAMILTON
Captain, USAF
Project Flight Test Engineer

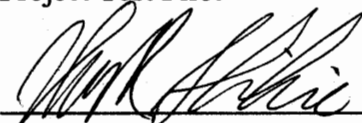

MICHAEL D. PRESNAR
Captain, USAF
Project Flight Test Engineer

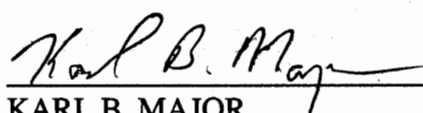

STUART M. REED
Squadron Leader, RAF
Project Test Pilot

JOHN R. SHINOSKIE
Captain, USAF
Project Flight Test Navigator

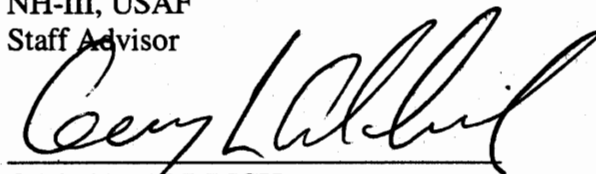
Reviewed by:

KARL B. MAJOR
NH-III, USAF
Staff Advisor

GARY L. ALDRICH
Test Management Branch

JOHN L. MINOR
NH-IV, USAF
Technical Director, USAF Test Pilot School

This report has been approved for
publication:

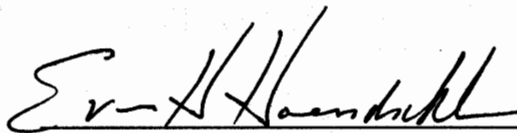
ERNIE H. HAENDSCHKE
Colonel, USAF
Commandant, USAF Test Pilot School

MAR 4 2005

REPORT DOCUMENTATION PAGE

Form Approved
OMB No. 0704-0188

Public reporting burden for this collection of information is estimated to average 1 hour per response, including the time for reviewing instructions, searching existing data sources, gathering and maintaining the data needed, and completing and reviewing this collection of information. Send comments regarding this burden estimate or any other aspect of this collection of information, including suggestions for reducing this burden to Department of Defense, Washington Headquarters Services, Directorate for Information Operations and Reports (0704-0188), 1215 Jefferson Davis Highway, Suite 1204, Arlington, VA 22202-4302. Respondents should be aware that notwithstanding any other provision of law, no person shall be subject to any penalty for failing to comply with a collection of information if it does not display a currently valid OMB control number. **PLEASE DO NOT RETURN YOUR FORM TO THE ABOVE ADDRESS.**

1. REPORT DATE 9 December 2004		2. REPORT TYPE Final Technical Information Memorandum		3. DATES COVERED (From - To) 14 October to 2 November 2004	
4. TITLE AND SUBTITLE Inertial Head Tracking for 3D Audio (Project "Sound Advice")				5a. CONTRACT NUMBER	
6. AUTHOR(S) Joffrion, Jacque M., Captain, USAF Delsing, Frank A., Captain, USAF Hamilton, Christopher E., Captain, USAF Presnar, Michael D., Captain, USAF Reed, Stuart M., Squadron Leader, RAF Shinoskie, John R., Captain, USAF				5b. GRANT NUMBER	
				5c. PROGRAM ELEMENT NUMBER	
				5d. PROJECT NUMBER	
				5e. TASK NUMBER	
				5f. WORK UNIT NUMBER	
7. PERFORMING ORGANIZATION NAME(S) AND ADDRESS(ES) Air Force Flight Test Center 412th Test Wing USAF Test Pilot School 220 South Wolfe Ave Edwards AFB CA 93524-6485				8. PERFORMING ORGANIZATION REPORT NUMBER AFFTC-TIM-04-06	
9. SPONSORING / MONITORING AGENCY NAME(S) AND ADDRESS(ES) AFRL/HECB Attn: Douglas S. Brungart 2610 Seventh Street Wright-Patterson AFB OH 45433-7901				10. SPONSOR/MONITOR'S ACRONYM(S)	
				11. SPONSOR/MONITOR'S REPORT NUMBER(S)	
12. DISTRIBUTION / AVAILABILITY STATEMENT Approved for public release; distribution is unlimited.					
13. SUPPLEMENTARY NOTES CA: Air Force Flight Test Center, Edwards AFB, CA CC: 012100					
14. ABSTRACT This report presents the results of a limited evaluation of a 3D Audio system on board a USAF C-12C aircraft under two system configurations: 3D Audio system coupled to a reference navigation system, and 3D Audio system coupled to an inertial head tracker. Testing began on 14 Oct 04 and was completed on 2 Nov 04 after eight sorties. Inertial head tracker angular accuracy when coupled to the aircraft frame was compared to the reference navigation system. The ability of the 3D Audio system to generate discernable directional sounds in ground and flight conditions was evaluated. The capability of the 3D Audio heading cue to provide heading information to the pilot with sufficient fidelity to fly to a specific heading was evaluated. Pilot orientation threshold was measured as the point where the pilot was aware that the aircraft was offset from level flight and could make a determination of offset direction (pitch up, pitch down, roll left, roll right) with no visual references. The system's capability to provide attitude information to the pilot to maintain vision-restricted straight-and-level flight was also tested.					
15. SUBJECT TERMS Cueing Cues (Stimuli) Directional Flight Testing Inertial Guidance Inertial Navigation Kalman Filtering Navigation Reference Pilots 3-D Audio Interface System 3-D Auditory Displays Artificial Horizon C-12 Aircraft Directional Signals GPS/INS Fusion GPS/INS Integration Head Tracking Systems IMU (Inertial Measurement Unit) Inertial Sensors MEMS (Microelectromechanical Systems) Navigation Reference Systems Pilot Cueing					
16. SECURITY CLASSIFICATION OF:			17. LIMITATION OF ABSTRACT SAME AS REPORT	18. NUMBER OF PAGES 68	19a. NAME OF RESPONSIBLE PERSON Douglas S. Brungart
a. REPORT Unclassified	b. ABSTRACT Unclassified	c. THIS PAGE Unclassified			19b. TELEPHONE NUMBER (include area code) (937) 255-3660 ext. 414

Standard Form 298 (Rev. 8-98)
Prescribed by ANSI Std. Z39.18

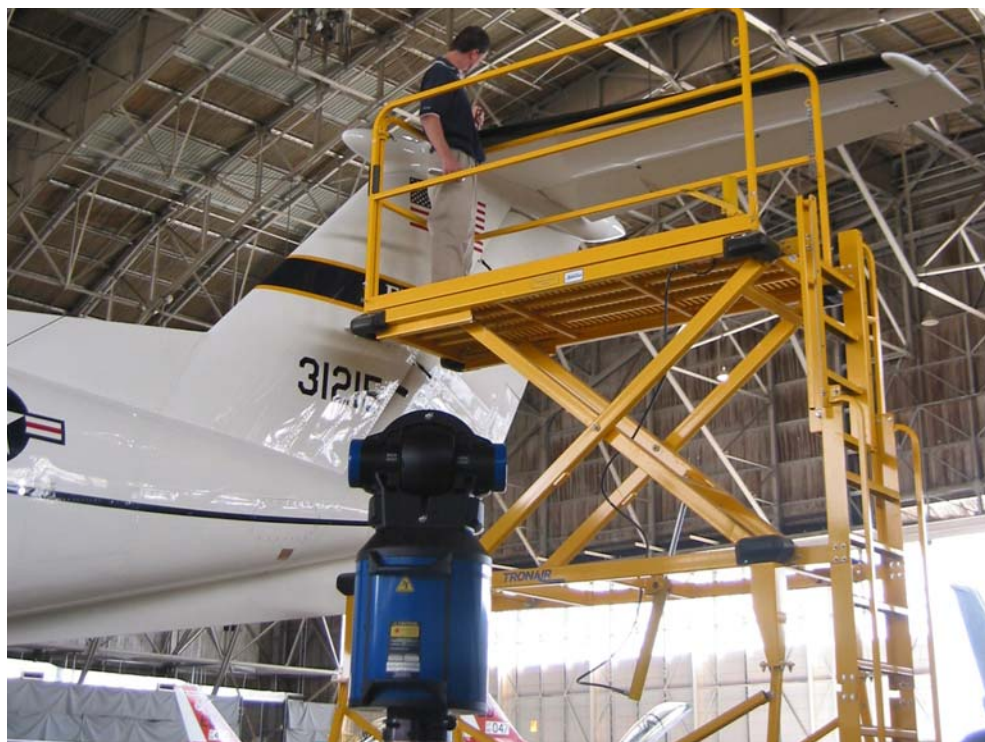

ACKNOWLEDGEMENTS

The Sound Advice test team would like to acknowledge the following people and organizations for their assistance and advice throughout this project.

412 TW/ENR TSPI Office: Larry V. Jones

412 TW/MXI: Charles A. Vatcher

AFRL/HECB: Douglas S. Brungart and Ron C. Dallman

USAF TPS Staff Advisor: Karl B. Major



EXECUTIVE SUMMARY

The US Air Force Test Pilot School class 04A Sound Advice test management project (TMP) group accomplished flight testing of a three-dimensional (3D) audio system along with a headset-mounted inertial measurement unit (IMU). This test project was conducted at the request of the Air Force Research Laboratory Human Effectiveness Directorate's Battlespace Acoustics Branch (AFRL/HECB). All testing was accomplished under TPS Job Order Number M04C0400. A total of 15.4 hours on 8 flight test sorties were flown in the R-2508 complex from 14 October to 2 November 2004.

An Air Force Flight Test Center (AFFTC), 412th Test Wing (TW), Raytheon C-12C Huron twin-engine turboprop transport aircraft, tail number 73-1215 was the test aircraft. The Head Tracker test hardware provided by AFIT/ENG included a low-cost microelectromechanical system (MEMS) based inertial measurement unit (IMU), a GPS receiver, and a laptop computer with interfacing software. The 3D Audio test hardware provided by AFRL/HECB included an audio headset, audio mixer, and laptop computer with 3D Audio software. Flight test support hardware provided by the TPS Special Instrumentation branch and the 412th TW provided a data acquisition system (DAS) and a reference INS with GPS aiding.

The test team successfully performed a limited evaluation of a 3D Audio system applied in the aviation environment under two system configurations: 3D Audio system coupled to the GPS Aided Inertial Navigation Reference (GAINR), and 3D Audio system coupled to the Head Tracker.

When the 3D audio system was coupled to the GAINR (aircraft's attitude), it did not provide sound cues with enough precision to allow pilots to determine the azimuth and elevation within operationally representative limits. Forward and aft audio cues were difficult to differentiate by the pilots leading to large heading and azimuth cue position errors. Forward and aft cue ambiguity was solved by adding a head-tracking system, but the addition of MEMS IMU heading drift over long periods of time degraded the overall system performance.

The ability of the Head Tracker-coupled (aircraft + pilot's head attitude) 3D Audio system to provide continuous and accurate cues to the pilot was limited by the angular accuracy of the inertial Head Tracker. Cruise flight requires a significant amount of straight-and-level flight, but the poor performance of the Head Tracker under these conditions led to inadequate 3D Audio performance. The 3D Audio system did not provide consistently discernable elevation cues, and the addition of the Head Tracker did not improve performance over the GAINR-coupled configuration. Applications such as collision avoidance systems and directional communications require accurate elevation information.

While the system was rated unsatisfactory in its current configuration, a notable improvement in the pilot's ability to sense attitude changes through 3D audio sound cues was observed when the audio gains were increased. This technology shows promise for providing pilots additional situational awareness through localized sounds and the audio horizon after further development.



Table of Contents

ACKNOWLEDGEMENTS	iv
ACKNOWLEDGEMENTS	v
EXECUTIVE SUMMARY	vi
EXECUTIVE SUMMARY	vii
List of Illustrations.....	x
List of Tables	xi
INTRODUCTION	1
Background.....	1
Program Chronology.....	1
Test Item Description.....	1
Test Team.....	2
Test Objectives.....	2
Limitations	2
TEST AND EVALUATION	3
General.....	3
Inertial Head Tracker Angular Accuracy.....	3
Directional Sound Localization	5
3D Audio Heading Cue.....	7
Change in Attitude and Pilot Threshold Angle.....	8
Straight-and-Level Flight 3D Audio Cues.....	10
Test and Evaluation Summary	12
CONCLUSIONS AND RECOMMENDATIONS	14
CONCLUSIONS AND RECOMMENDATIONS	15
REFERENCES	17
APPENDIX A – DETAILED TEST ARTICLE DESCRIPTION.....	A1
APPENDIX B – TEST SUMMARY AND MANEUVER SET	B1
APPENDIX C – DATA	C1
APPENDIX D – LIST OF ACRONYMS.....	D1
APPENDIX E – DISTRIBUTION LIST	E1

List of Illustrations

Figure 1. Head Tracker Orientation and Test Angle Set	6
Figure A-1. C-12C Tail # 73-1215 Test and Support Hardware	A2
Figure C-1. Head Tracker Angular Performance in Climb.....	C1
Figure C-2. Head Tracker Angular Accuracy in Climb.....	C1
Figure C-3. Head Tracker Angular Performance in Straight & Level Unaccelerated Flight	C2
Figure C-4. Head Tracker Angular Accuracy in Straight & Level Unaccelerated Flight	C2
Figure C-5. Head Tracker Angular Performance in Constant G Turn.....	C3
Figure C-6. Head Tracker Angular Accuracy in Constant G Turn.....	C3
Figure C-7. Head Tracker Angular Performance in Steady Heading Side Slip.....	C4
Figure C-8. Head Tracker Angular Accuracy in Steady Heading Side Slip.....	C4
Figure C-9. Head Tracker Angular Performance in Level Acceleration	C5
Figure C-10. Head Tracker Angular Accuracy in Level Acceleration	C5
Figure C-11. Head Tracker Angular Performance in Level Deceleration	C6
Figure C-12. Head Tracker Angular Accuracy in Level Deceleration	C6
Figure C-13. Head Tracker Angular Performance in Roller Coaster	C7
Figure C-14. Head Tracker Angular Accuracy in Roller Coaster	C7
Figure C-15. Head Tracker Angular Performance during Yoke Raps.....	C8
Figure C-16. Head Tracker Angular Accuracy during Yoke Raps.....	C8
Figure C-17. Head Tracker Angular Performance during Pitch/Rudder Doublets.....	C9
Figure C-18. Head Tracker Angular Accuracy during Pitch/Rudder Doublets.....	C9
Figure C-19. Head Tracker Angular Performance in 30°-30° Angle-of-Bank Rolls.....	C10
Figure C-20. Head Tracker Angular Accuracy in 30°-30° Angle-of-Bank Rolls	C10
Figure C-21. Head Tracker Angular Performance in Descent.....	C11
Figure C-22. Head Tracker Angular Accuracy in Descent.....	C11
Figure C-23. GAINR-Coupled Localization Azimuth Response Percentages	C12
Figure C-24. GAINR-Coupled Localization Azimuth Error	C12
Figure C-25. GAINR-Coupled Localization Elevation Response Percentages.....	C13
Figure C-26. GAINR-Coupled Localization Elevation Error.....	C13
Figure C-27. Head Tracker-Coupled Localization Azimuth Response Percentages.....	C14
Figure C-28. Head Tracker-Coupled Localization Azimuth Error	C14
Figure C-29. Head Tracker-Coupled Localization Elevation Response Percentages.....	C15
Figure C-30. Head Tracker-Coupled Localization Elevation Error.....	C15
Figure C-31. Baseline Verbal Heading Cue Performance	C16
Figure C-32. GAINR-Coupled Heading Cue Performance	C16
Figure C-33. Head Tracker-Coupled Heading Cue Performance.....	C16
Figure C-34. Pilot #1 Baseline Verbal Heading Cue Performance	C17
Figure C-35. Pilot #1 GAINR-Coupled 3D Audio Heading Cue Performance.....	C17
Figure C-36. Pilot #2 Baseline Verbal Heading Cue Performance	C18
Figure C-37. Pilot #2 GAINR-Coupled 3D Audio Heading Cue Performance.....	C18
Figure C-38. Pilot #3 Baseline Verbal Heading Cue Performance	C19
Figure C-39. Pilot #3 GAINR-Coupled 3D Audio Heading Cue Performance.....	C19
Figure C-40. Pilot #1 Baseline Verbal Heading Cue Performance	C20
Figure C-41. Pilot #1 Head Tracker-Coupled 3D Audio Heading Cue Performance	C20

Figure C-42. Pilot #2 Baseline Verbal Heading Cue Performance	C21
Figure C-43. Pilot #2 Head Tracker-Coupled 3D Audio Heading Cue Performance	C21
Figure C-44. Pilot #3 Baseline Verbal Heading Cue Performance	C22
Figure C-45. Pilot #3 Head Tracker-Coupled 3D Audio Heading Cue Performance	C22
Figure C-46. Correct Responses to Change in Attitude with Low-Gain 3D Audio	C23
Figure C-47. Mean Threshold Angles with Low-Gain 3D Audio	C23
Figure C-48. Correct Responses to Change in Attitude with High-Gain 3D Audio.....	C24
Figure C-49. Mean Threshold Angles with High-Gain 3D Audio	C24
Figure C-50. Straight/Level Flight Roll Angle with No Audio Reference.....	C25
Figure C-51. Straight/Level Flight Roll Angle with Low-Gain GAINR-Coupled 3D Audio...	C25
Figure C-52. Straight/Level Flight Pitch Angle with No Audio Reference	C26
Figure C-53. Straight/Level Flight Pitch Angle with Low-Gain GAINR-Coupled 3D Audio..	C26
Figure C-54. Straight/Level Flight Heading with No Audio Reference.....	C27
Figure C-55. Straight/Level Flight Heading with Low-Gain GAINR-Coupled 3D Audio	C27
Figure C-56. Straight/Level Flight Roll Angle with No Audio Reference.....	C28
Figure C-57. Straight/Level Flight Roll Angle with High-Gain GAINR-Coupled 3D Audio ..	C28
Figure C-58. Straight/Level Flight Pitch Angle with No Audio Reference	C29
Figure C-59. Straight/Level Flight Pitch Angle with High-Gain GAINR-Coupled 3D Audio..	C29
Figure C-60. Straight/Level Flight Heading with No Audio Reference.....	C30
Figure C-61. Straight/Level Flight Heading with High-Gain GAINR-Coupled 3D Audio	C30

List of Tables

Table 1. Pilot Experience Levels	2
Table 2. Inertial Head Tracker Summary of Results	4
Table 3. Directional Sound Localization Results	6
Table 4. Summary of Percent Improvement over No Audio Baseline	9
Table 5. Straight-and-Level Flight Evaluation Summary	11
Table 6. 3D Audio Evaluation Summary.....	13
Table A-1. Selected Music for 3D Audio Horizon Cue.....	A1
Table B-1. Sound Advice Test Summary	B1
Table B-2. C-12C Aircraft Maneuver Set for Inertial Head Tracker Angular Accuracy	B2



INTRODUCTION

Background

The program came about through the joint efforts of AFRL/HECB, the Air Force Institute of Technology Department of Electrical and Computer Engineering (AFIT/ENG), and USAF Test Pilot School Education Division, Test Management Branch (TPS/EDT). The three-dimensional (3D) audio technology developed by AFRL/HECB required testing for aviation applications. AFIT/ENG proposed integrating an inertial Head Tracker into the 3D Audio system, and TPS/EDT assigned Captain Joffrion of TPS/04A as the project manager to lead the integration and test efforts. Elements of an effective 3D Audio cueing system include knowledge of the orientation of the pilot's head; therefore part of this test was to see if this angular measurement, to the desired degree of accuracy, was possible. The ultimate goal of an integrated system would be to provide audio cues, directionally locatable by the pilot, for aircraft attitude awareness (e.g., to maintain straight-and-level flight in lieu of other attitude information) and also 3D directional attention cueing (e.g., to cue the pilot to a particular point or area of interest).

Program Chronology

Aircraft modifications were completed on 18 August 2004. Flight testing was conducted between 14 October 2004 and 2 November 2004.

Test Item Description

The inertial Head Tracker consisted of a microelectromechanical system (MEMS) inertial measurement unit (IMU), Garmin GPS receiver, pan-and-tilt actuator and controller, a Direct/Alternating Current (DC/AC) power inverter, and laptop computer. The pan-and-tilt actuator was intended to simulate head movement. All inertial Head Tracker equipment was provided by AFIT/ENG.

The integrated 3D Audio system consisted of a stereo headset, audio mixer, and a laptop computer provided by AFRL/HECB. The 3D Audio system provided audio cues to the evaluation pilot. The angular orientation of the evaluation pilot's head was obtained from the inertial Head Tracker system and was provided to the 3D Audio system. Audio from the aircraft intercom system was mixed with audio cues from the 3D Audio system.

The test support hardware consisted of a Time, Space, and Position Information (TSPI) GPS Aided Inertial Navigation Reference (GAINR) system as the primary source of truth data (Reference 1) and the C-12C aircraft data acquisition system (DAS) instrumentation. All test support hardware was supplied by Edwards AFB range (412 TW/ENR) and special instrumentation (USAF TPS/TS) personnel.

A single C-12C Huron test aircraft, tail # 73-1215, was used to collect data for this analysis. The C-12C was a Raytheon King Air twin-engine turboprop transport aircraft. A

detailed description of the C-12C can be found in the C-12C Flight Manual (Reference 2). Detailed descriptions of aircraft modifications can be found in the Modification Flight Manual (MFM) (Reference 3) and Modification Operational Supplement (MOS) (Reference 4). The test aircraft integration of the inertial Head Tracker, 3D Audio system, and test support hardware listed above is shown in Figure A-1.

Test Team

The test team consisted of six members of Class 04A at the USAF Test Pilot School. Three of the six members were pilots and all participated in the flight testing. Table 1 contains a matrix of the experience for the test pilots.

Table 1. Pilot Experience Levels

Test Pilot	Aircraft Experience	Years of Flight Experience
1	B-1B	8
2	C-130H, C-21A	8
3	CF-18A/B, F-3 Tornado	15

Test Objectives

The overall test objective in the Sound Advice Test Plan (Reference 5) was to perform a limited evaluation of a 3D Audio system applied in the aviation environment under two system configurations: 3D Audio system coupled to the GAINR and 3D Audio system coupled to the Head Tracker.

The specific objectives were:

1. Determine inertial Head Tracker angular accuracy with and without simulated head movement.
2. Evaluate the 3D Audio system's capability to provide discernable heading and attitude audio cues under the two system configurations: 3D Audio system coupled to the GAINR and 3D Audio system coupled to the Head Tracker.

Limitations

The simulated head movement portion of objective 1 was not met due to the inoperability of the pan and tilt actuator. The actuator proved to be incompatible with aircraft power, and therefore was not usable in the test environment.

TEST AND EVALUATION

General

The overall test objective was to perform a limited evaluation of a 3D Audio system applied in the aviation environment under two system configurations: 3D Audio system coupled to the GAINR and 3D Audio system coupled to the Head Tracker. A total of 8 sorties were flown for 15.4 hours of flight time between 14 October and 2 November 2004, and an indoor ground baseline measurement was also performed on the 3D Audio system coupled to the Head Tracker. The completed tasks for each of these tests are summarized in Table B-1.

Inertial Head Tracker Angular Accuracy

This test objective was to determine inertial head tracker angular accuracy with the inertial measurement unit fixed to the aircraft body frame.

Procedures

Before the Head Tracker's angular accuracy was evaluated, one flight was dedicated to collect position, velocity, and attitude data from both the inertial Head Tracker and the GAINR system. These data were used to refine the parameters that make up the dynamics model and measurement model of the Head Tracker Kalman filter. The Head Tracker was then evaluated using the updated Kalman filter parameters.

The Head Tracker evaluation was accomplished by exposing the system to various types of accelerations and angular rates. Roll, pitch, and yaw were recorded by the Head Tracker as well as by the Time, Space, and Position Information (TSPI) GPS Aided Inertial Navigation Reference (GAINR) system during each maneuver listed in Table B-2. The TSPI GAINR system was used as a truth source for the evaluation. Aircraft configuration for all test points was gear up and flaps up. The propeller speed was 1700 rpm, except for the climb in which it was set to 1900 rpm. The maneuvers were flown in the data band between 120 KIAS to 230 KIAS and 8,000 feet to 20,000 feet pressure altitude.

Results

A summary of the angular accuracy results for each maneuver is depicted in Table 2. Associated roll, pitch, and heading performance and error plots are displayed in Figures C-1 to C-22. The Head Tracker was considered satisfactory if the angular accuracy for 90 percent of the samples was within ± 3 degrees and marginal if the angular accuracy for 90 percent of the samples was within ± 7 degrees. Otherwise the performance was deemed unsatisfactory.

Table 2. Inertial Head Tracker Summary of Results

Maneuver	Roll	Pitch	Heading
Climb	Marginal 86% < 3° 100% < 7°	Satisfactory 96% < 3° 100% < 7°	Unsatisfactory 33% < 3° 76% < 7°
Straight and Level Unaccelerated Flight	Satisfactory 100% < 3°	Satisfactory 100% < 3°	Unsatisfactory 23% < 3° 59% < 7°
Constant G Turns	Marginal 87% < 3° 99% < 7°	Satisfactory 100% < 3°	Marginal 49% < 3° 93% < 7°
Steady Heading Side Slip	Satisfactory 100% < 3°	Satisfactory 100% < 3°	Marginal 69% < 3° 99% < 7°
Level Acceleration	Satisfactory 100% < 3°	Satisfactory 100% < 3°	Marginal 73% < 3° 100% < 7°
Level Deceleration	Satisfactory 100% < 3°	Satisfactory 100% < 3°	Satisfactory 92% < 3° 100% < 7°
Roller Coaster	Satisfactory 100% < 3°	Satisfactory 96% < 3° 100% < 7°	Unsatisfactory 32% < 3° 84% < 7°
Yoke Raps	Satisfactory 100% < 3°	Satisfactory 100% < 3°	Marginal 72% < 3° 100% < 7°
Pitch / Rudder Doublets	Marginal 79% < 3° 97% < 7°	Satisfactory 100% < 3°	Unsatisfactory 32% < 3° 37% < 7°
30° to 30° Bank to Bank Rolls	Unsatisfactory 59% < 3° 74% < 7°	Satisfactory 93% < 3° 100% < 7°	Marginal 72% < 3° 100% < 7°
Descent	Marginal 33% < 3° 99% < 7°	Satisfactory 97% < 3° 100% < 7°	Unsatisfactory 7% < 3° 13% < 7°
Overall	Marginal	Satisfactory	Unsatisfactory
Satisfactory (at least 90% of samples < 3°) Marginal (at least 90% of samples < 7°) Unsatisfactory (otherwise)			

Roll accuracy was marginal. Accuracy was best during wings-level type maneuvers, e.g., roll error was within ±3 degrees 100 percent of the time during straight-and-level flight. The accuracy degraded during rolling maneuvers with the worst case being the 30 degree to 30 degree bank-to-bank roll, where the roll error was within ±7 degrees for 74 percent of the samples. Overall, the roll performance was deemed marginal because of inaccuracy of the Head

Tracker during constant-G turns and 30 degree to 30 degree bank-to-bank rolls, where roll information was important.

Pitch accuracy was satisfactory. All maneuvers flown met satisfactory criteria. The least accurate maneuver was 30 degree to 30 degree bank-to-bank rolls, when the Head Tracker maintained ± 3 degrees for 93 percent of the samples.

Heading accuracy was unsatisfactory. Head Tracker accuracy decreased during maneuvers with little or no lateral acceleration. This was evident in the climb, straight and level unaccelerated flight, roller coaster, and descent. The Head Tracker's heading was least accurate during descent, where it was within ± 7 degrees only 13 percent of the time.

Overall, due to the unsatisfactory heading accuracy of the Head Tracker, the system was **Unsatisfactory**. The pan-and-tilt actuator, which was intended to simulate head movement in azimuth and elevation, would have provided additional data for the head tracker in specific measurable orientations other than the body axes. However, the performance of the Head Tracker when fixed to the body frame alone drove the overall unsatisfactory rating. Head Tracker accuracy in all three axes was important for determining head orientation of the pilot, which was directly proportional to the accuracy of the 3D audio cues. **Improve inertial Head Tracker angular accuracy (R1)**¹.

Directional Sound Localization

The system's ability to generate audio cues from a specific azimuth and elevation combination was evaluated. The audio cue used was modulated wideband noise processed to sound as though it were coming from a certain location (i.e. spatially located).

Procedures

Data were gathered in a non-flying environment (i.e. closed door briefing room), in the aircraft on the ground with engines running, and in-flight. During the in-flight test, the evaluation pilot flew the aircraft to maintain straight-and-level flight. The test conductor initiated a set of azimuth/elevation angle sound cues (see Figure 1), which were presented to the pilot in a random order. The azimuth of the sound cue was generated with reference to the current aircraft heading. At the completion of each aural presentation, the pilot responded with the clock position and elevation (e.g. 3 o'clock low) from which he perceived the sound to be emanating. The test conductor recorded the pilot's response and the commanded sound position. These tests were performed both with the 3D audio system coupled to the GAINR and coupled to the Head Tracker.

¹Numerals preceded by an R within parentheses at the end of a paragraph correspond to the recommendation numbers tabulated in the Conclusions and Recommendations section of this report.

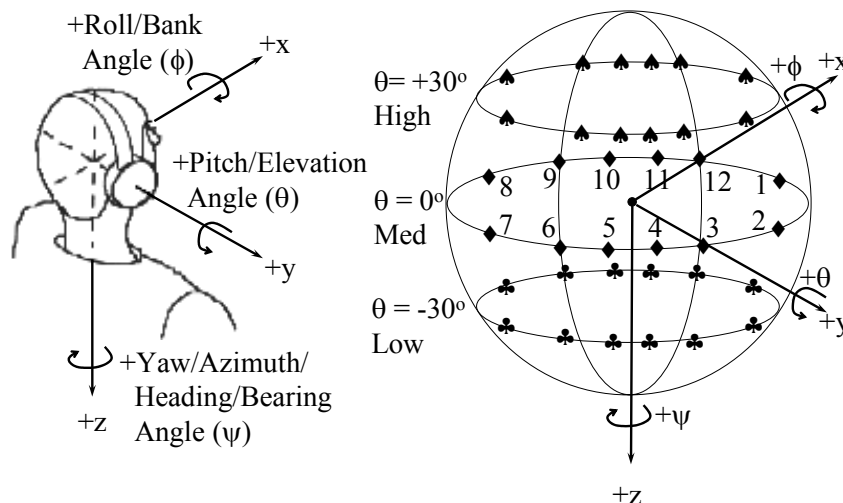

Figure 1. Head Tracker Orientation and Test Angle Set

Results

A summary of the directional sound localization results is depicted in Table 3 below and in Figures C-23 to C-30. The evaluation criteria were based on average error, correct responses, and pilot comments.

Table 3. Directional Sound Localization Results

	GAINR-Coupled	Head Tracker-Coupled
Airborne Azimuth	Unsatisfactory	Satisfactory
Airborne Elevation	Unsatisfactory	Unsatisfactory

With the system coupled to the GAINR, the average azimuth angle reporting error for the three evaluation pilots was 40 degrees both on the ground and in the air as shown in Figure C-24. A better representation of system performance was the percentage of correct responses. With the system coupled to the GAINR, 40 percent of the azimuth angle responses were correct both on the ground and in the air as shown in Figure C-23. The figure depicts an improvement over the 8.33 percent occurrence rate of the 12 clock positions. The GAINR-coupled system was ambiguous between forward and aft azimuths. Cues from a forward azimuth (e.g., 11 o'clock) were difficult to distinguish from cues from an aft azimuth (e.g., 7 o'clock). Left and right azimuths were easily discerned. Because of the ambiguities in the GAINR-coupled system and its large average azimuth error, the azimuth rating was unsatisfactory.

Average GAINR-coupled elevation angle error was 22 degrees on the ground and 20 degrees in the air as shown in Figure C-26. Only 40 percent of the elevation angle responses were correct both on the ground and in the air, which was not a significant improvement over the 33 percent occurrence rate of the three possible elevation angles. This shows that the system could not accurately generate discernable elevation cues and therefore was unsatisfactory.

With the system coupled to the Head Tracker, reported azimuth accuracy was significantly better. The average azimuth angle reporting error for the three evaluation pilots was 14 degrees on the ground and 8 degrees in the air as shown in Figure C-28. The Head

Tracker-coupled system eliminated azimuth ambiguities by its improved localization capability, greatly improving the azimuth performance of the 3D Audio system. The addition of the Head Tracker also greatly reduced the azimuth error by giving a pilot the ability to center a sound at a specific point in space by turning his head. With the system coupled to the Head Tracker, 56 percent of the azimuth angle responses were correct on the ground and 72 percent in the air as shown in Figure C-27. The figure depicts a large improvement over the 8.33 percent occurrence rate of the 12 clock positions. Because the Head Tracker-coupled system eliminated azimuth ambiguities thereby increasing correct responses and decreasing error to usable levels, the system was rated satisfactory in azimuth localization.

Average Head Tracker-coupled elevation angle error was 22 degrees on the ground and 20 degrees in the air as shown in Figure C-30. The correct responses were 42 percent on the ground and 46 percent in the air which were not significant improvements over the 33 percent occurrence rate. The 3D Audio system did not provide consistently discernable elevation cues, and the addition of the Head Tracker did not improve performance over the GAINR-coupled configuration and was still unsatisfactory in elevation.

Applications such as collision avoidance systems, directional communications and radar warning receivers would be enhanced by the availability of accurate elevation information. For a collision avoidance system, a directional cue could aid the pilot in visually acquiring the conflicting traffic, particularly if the traffic is not within the natural pilot elevation scan cone (approximately 10 degrees above and below the horizon). 3D Audio based intraflight communication systems, where the receiving pilot hears a transmission from the specific elevation (and azimuth) angle of the transmitting aircraft, could improve the situational awareness of the pilot by cueing him to the location of the formation member who is transmitting. Applications such as radar warning receivers could improve situational awareness by providing an audio elevation cue (in addition to an audio azimuth cue) from the threat direction. For example, a surface to air missile radar illuminating the aircraft would be 'heard' coming from a particular point on the ground. **Improve elevation performance of the 3D Audio system (R2).**

3D Audio Heading Cue

The system's ability to generate audio cues suitable for heading guidance was evaluated. The cue was identical to that used for the directional sound localization evaluation.

Procedures

Each heading capture trial required the evaluation pilot to change the heading of the aircraft to match the commanded heading. This task consisted of 15 total trials for each of the three evaluation pilots. Five of the cues were given by a nonspatialized verbal audio cue (e.g. a voice saying "Set Course, 315"), after which the evaluation pilot turned the aircraft to the commanded heading using the HSI as a reference. The other ten cues were given by a spatialized auditory "navigation beacon" cue. The evaluation pilot turned the aircraft until he perceived that the aircraft heading matched the direction from which the spatialized auditory cue originated. The nonspatialized heading captures were used as a baseline for comparison to the

spatialized cues. In all heading captures, the evaluation pilot indicated verbally to the test conductor when he had maneuvered the aircraft to the commanded heading. The actual headings were measured by the GAINR system, and compared with the target headings for final error analysis. The heading capture task was conducted for both system configurations (GAINR-coupled and Head Tracker-coupled).

Results

The system was considered satisfactory if the aircraft could be turned to a heading within ± 10 degrees with no more than 2 overshoots in 90 percent of the trials, and marginal if the aircraft could be turned to a heading within ± 20 degrees with no more than 3 overshoots in 90 percent of the trials. All pilots were able to turn the aircraft to less than 10 degrees of heading error with no more than 1 overshoot in 100 percent of the trials using the baseline nonspatialized verbal audio cue, as shown in Figure C-31. For both the GAINR-coupled and the Head Tracker-coupled cases, the results were **Marginal** as shown in Figures C-32 and C-33. The final heading accuracy with the Head Tracker-coupled configuration was worse than the GAINR-coupled configuration. The GAINR-coupled configuration had the same forward-aft ambiguity problem as in the Directional Sound Localization task above, requiring the pilot to initially turn the aircraft to resolve the ambiguity. This deficiency was corrected in the Head Tracker-coupled configuration, as the pilot only needed to turn his head to determine if the cue was coming from ahead of or behind him. However, the heading accuracy of the Head Tracker progressively degraded throughout the trials. The Head Tracker was realigned in the air between trials whenever its heading drifted off by 10 degrees relative to the HSI heading. This aspect of the Head Tracker caused the percentage of correct responses to be slightly less than in the GAINR-coupled configuration and the percentage would have been significantly less had it not been for air realignments every few trials.

Using either configuration of the 3D Audio system, the aircraft could not be turned to within ± 10 degrees in 90 percent of the trials, as confirmed by the time histories in Figures C-34 to C-45. This error was not compatible with enroute navigation tasks. For example, aircraft flying under an IFR clearance are limited to within 4 nautical miles of assigned course (Reference 6). Thus, an aircraft flying 10 degrees off heading at 360 knots ground speed would exceed the 4 nautical mile course limit in approximately 4 minutes. **Increase the precision of the 3D Audio cues near the commanded heading (R3).**

Change in Attitude and Pilot Threshold Angle

The system's ability to generate attitude cues sufficient to alert the pilot to a change from straight-and-level flight was evaluated.

Procedures

The trials alternated between 3D Audio cue on and 3D Audio cue off (no-audio baseline). Using the GAINR-coupled 3D Audio system, roll and pitch information were presented as an audio "horizon" cue (music) above the pilot's head. The selected music for each pilot is summarized in Table A-1. Zero roll was indicated by an audio horizon directly above the head. Right bank would move the audio horizon toward the left ear, and left bank would move the

audio horizon toward the right ear. The bass/treble balance of the music would vary with aircraft pitch attitude. As the pitch attitude increased above the natural horizon, the tone of the music would become higher; as the pitch attitude decreased below the natural horizon the tone would become lower. To begin the trial, the safety pilot flew the aircraft in straight-and-level unaccelerated flight. The evaluation pilot donned a vision restricting device and the safety pilot changed the roll or pitch attitude of the aircraft at a target rate of one degree per second to minimize vestibular or “seat-of-the-pants” perception of motion. During the test point, the evaluation pilot called out either “Pitch Up”, “Pitch Down”, “Roll Left”, or “Roll Right” at the point where he perceived the change in attitude. Correctness of response and aircraft attitude at the time of the response was recorded. The maneuver was terminated if either test limits of $\pm 10^\circ$ of pitch or 30° of bank were reached prior to a response from the evaluation pilot or if the aircraft was flown outside the data band. Each evaluation pilot evaluated 20 attitude changes per system configuration presented in a random order alternating between 3D Audio on and off.

One important enhancement to the 3D Audio system took place amid testing. Pilot comments during early flight testing indicated that the ratio of sound pitch (tone) change to aircraft pitch (attitude) change was too low. The gains of sound pitch change and perceived audio roll cues were both increased relative to actual aircraft movement. Hence, low-gain results were compared with high-gain results. At the customer's request, the inertial Head Tracker-coupled 3D Audio system was not tested in this task.

Results

A summary of the change in attitude and pilot threshold angle results is depicted in Table 4 below and in Figures C-46 to C-49. The system was considered satisfactory if there was a 10 percent improvement in correct responses to changes in attitude, and marginal if there was a 5 percent improvement, relative to the no-audio baseline.

Table 4. Summary of Percent Improvement over No Audio Baseline

	Low-Gain Configuration	High-Gain Configuration
Right	+9% (Marginal)	+42% (Satisfactory)
Left	+11% (Satisfactory)	+16% (Satisfactory)
Up	+25% (Satisfactory)	+57% (Satisfactory)
Down	-27% (Unsatisfactory)	+38% (Satisfactory)
Overall	Unsatisfactory	Satisfactory

The results showed that pilot orientation threshold in the low-gain configuration differed depending upon the type of attitude change. For roll right, roll left and pitch up changes, the pilot was able to determine attitude change more frequently when the audio horizon was present. However, the reverse was true for the pitch down, as seen in Figures C-46 and C-48. The pilots were able to discern roll changes better than pitch changes using the low-gain 3D Audio system. Because of the degraded performance of the low-gain configuration relative to the no-audio baseline in the pitch down case, the low-gain 3D Audio system was **Unsatisfactory**.

Using the high-gain audio cue, the pilots were able to determine attitude changes in all four directions more frequently than the no-audio baseline. The pilots found the high-gain configuration significantly improved their perception of both roll and pitch changes. The high-

gain right and left roll mean threshold angles decreased relative to the low-gain configuration, as shown in Figures C-47 and C-49. Because of the greater than 10 percent improvement of the high-gain configuration relative to the no-audio baseline in all four directions, the high-gain 3D Audio system was **Satisfactory**.

The pilots were given the opportunity to choose their own music for the 3D Audio system's audio horizon cue. It was observed that the frequency content of the music either affected the bass/treble pitch response. This could potentially affect the performance of the audio horizon cue in any configuration of the 3D Audio system. **Investigate the effects of the frequency content of the music used for the audio horizon cue (R4).**

Straight-and-Level Flight 3D Audio Cues

The system's ability to generate audio cues sufficient for the pilot to maintain straight-and-level flight without visual or instrument reference was evaluated. The 3D Audio system audio horizon cue provided attitude feedback to the pilot, while the heading cue provided azimuth feedback.

Procedures

Each trial of the straight and level task started with the evaluation pilot performing a trim shot on a desirable heading. The evaluation pilot donned the vision restriction device and attempted to maintain straight-and-level flight for 5 minutes. The safety pilot closely monitored aircraft parameters and took control of the aircraft if flown outside of the test limits (± 30 degrees roll and ± 10 degrees pitch). At any early termination of the trial, the safety pilot assumed control of the aircraft and the data recording was paused. When the situation allowed, the safety pilot retrimmed the aircraft and the evaluation pilot resumed the trial in the same configuration. Each trial was complete when five minutes of data were accumulated. Each pilot performed a pair of straight-and-level flight trials with low-gain 3D Audio cue on and off and repeated the pair of trials with high-gain 3D Audio cue on and off. At the customer's request, the inertial Head Tracker-coupled 3D Audio system was not tested in this task.

Results

A summary of the change in attitude and pilot threshold angle results is depicted in Table 5 below and in Figures C-50 to C-61. The system was considered satisfactory if straight-and-level flight (± 7 degrees roll, ± 4 degrees pitch, ± 15 degrees heading) could be maintained throughout 90 percent of the time and unsatisfactory otherwise. During testing, it was discovered that the marginal rating definition in the test plan (Reference 5) of a 20 percent improvement of the test system over the no-audio baseline could not be used. This was because the no-audio case was primarily a function of initial trim shot and natural stability of the aircraft, not the pilot's ability to maintain straight-and-level flight.

Table 5. Straight-and-Level Flight Evaluation Summary

Pilot	Parameter	No Audio #1	No Audio #2	Low Gain Audio	High Gain Audio
1	Roll	No Data	70% (U*)	40% (U)	44% (U)
	Pitch	No Data	100% (S*)	95% (S)	100% (S)
	Heading	No Data	29% (U)	21% (U)	35% (U)
2	Roll	8% (U)	33% (U)	46% (U)	97% (S)
	Pitch	100% (S)	99% (S)	96% (S)	100% (S)
	Heading	13% (U)	43% (U)	67% (U)	78% (U)
3	Roll	100% (S)	36% (U)	92% (S)	100% (S)
	Pitch	100% (S)	100% (S)	100% (S)	100% (S)
	Heading	88% (U)	34% (U)	27% (U)	71% (U)
Overall		U	U	U	U

* S = Satisfactory, U = Unsatisfactory

In the no-audio trials, it was difficult to determine aircraft deviation from straight-and-level flight without an external attitude reference. Therefore, very few inputs were made to correct aircraft attitude without the audio cue. The results of the no-audio tests were dependent on the initial trim shot and natural stability of the aircraft due to the lack of pilot inputs. Results of the first no-audio cue tests are presented for pilots two and three only due to system malfunctions for pilot one.

The low-gain 3D Audio cues provided sufficient information to the pilot to make inputs for attitude and heading correction. Roll angle performance was unsatisfactory, since pilots tended to have difficulty maintaining a level roll angle, instead oscillating up to 25 degrees around the level condition. Pitch angle control was satisfactory, although it remained erratic and similar to the no audio reference results as pilots found the pitch cues difficult to discern. Heading angle control was unsatisfactory since pilots were unable to maintain heading within ± 15 degrees. The heading error tended to increase as the task continued due to the inability of the pilot to discern ± 15 degrees found in the 3D Audio heading cue task.

The high-gain 3D Audio was an improvement for all three subject pilots. Roll angle improved for pilots two and three with bank angle remaining within $\pm 7^\circ$ for more than 90 percent of the time. Pilot 1 exceeded the 30 degree bank angle limit while attempting to recapture the initial heading based off of the azimuth cue. Pitch angle performance met satisfactory criteria for all three pilots, and pitch boundaries were never exceeded. Heading angle was improved over the low-gain configuration for pilots two and three, but was still unsatisfactory with heading being maintained within 15 degrees for 78 percent of the time.

Both the low-gain and high-gain 3D Audio configurations were **Unsatisfactory**. The 3D Audio system could not be used to precisely maintain heading within ± 10 degrees in 90 percent of the trials in the previously discussed 3D Audio Heading Cue task. Improving the heading precision of the 3D Audio system would allow the system to be used for a wider variety of applications.

Pilots were unaware of approaching roll and/or pitch limits. Adding an audio cue when the aircraft is approaching limits would prevent the pilot from overcorrecting from deviations. **Add an audio indication when approaching a preset attitude limit (R5).** The present system provides no altitude information to the pilot and the slightest pitch deviation from level flight would cause large altitude deviations over time. **Add an audio indication of altitude (R6).**

Test and Evaluation Summary

The inertial Head Tracker performance was not adequate in its tested configuration to provide reliable heading data to the 3D Audio system. The Head Tracker would maintain accurate heading for a few minutes but would drift in heading and sometimes pitch and roll if unaccelerated flight was maintained for any extended amount of time. When evaluating the 3D Audio system, the Head Tracker was realigned if the system started to drift in roll, pitch, or heading. This was sufficient to test the capability of the 3D Audio System however, in its tested configuration the Head Tracker would not be suitable to use in an operational environment due to the number of realignments required.

Even so the Head Tracker system demonstrated that a low cost MEMS IMU can provide attitude information. Under the time constraints of this test program, only a single iteration of Kalman filter parameter refinement was accomplished. Continued development of the system to include further tuning of the Kalman filter, the use a higher quality IMU, investigation of different INS mechanizations schemes, or the use of higher order state models may provide the needed angular accuracy. **Continue to develop, test, and evaluate MEMS IMU technology for the use of inertial head tracking (R7).**

The 3D Audio system excelled in two main areas. First, the system demonstrated a basic ability to generate audio cues directional in azimuth in actual flight conditions. The airborne azimuth localization was actually better than the azimuth localization on the ground with the engines running. Second, it outperformed pilot vestibular perception in warning the pilot of aircraft attitude changes. A definite improvement in correct responses and pilot orientation threshold was observed when using the 3D Audio system.

However, elevation directionality of audio cues was not perceivable under most circumstances. This can be alleviated in some applications by changing the bass/treble balance of the audio cue with respect to the pitch axis of the aircraft. In general this technique provides relative elevation type information to the pilot but was difficult to establish a neutral point of the bass/treble balance.

Finally, any azimuth cues within approximately 20 degrees of 6 or 12 o'clock sounded similar and were difficult to distinguish. As a result, the use of the 3D Audio heading cue to turn to or maintain a heading was problematic. A summary of the 3D Audio test results in the best performing configuration is given below in Table 6.

Table 6. 3D Audio Evaluation Summary

Test	Best Configuration	Evaluation
Directional Sound Localization - Azimuth	Head Tracker-Coupled	Satisfactory
Directional Sound Localization - Elevation	Either Configuration	Unsatisfactory
3D Audio Heading Cue	GAINR-Coupled	Marginal
Change in Attitude and Pilot Threshold Angle	High Gain	Satisfactory
Straight-and-Level Flight 3D Audio Cues	High Gain	Unsatisfactory

Although the tested configurations of the 3D Audio system met satisfactory evaluation criteria in only two areas, the system has significant potential to increase pilot situational awareness and should be investigated further. **Continue to develop, test, and evaluate 3D Audio technology for use in flight (R8).**

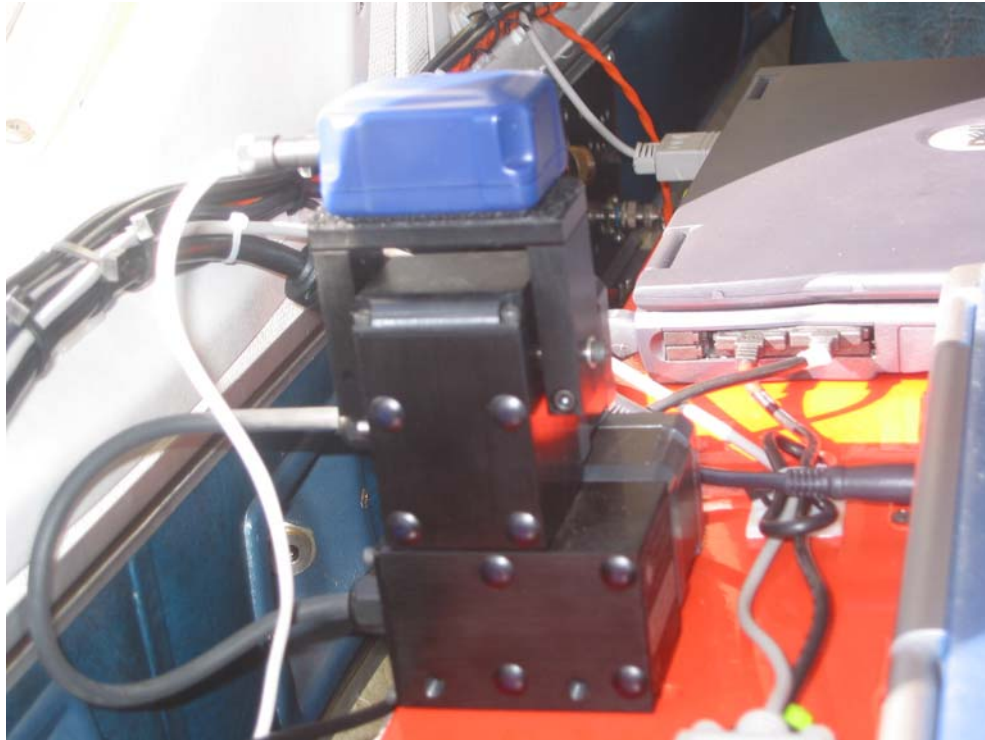

CONCLUSIONS AND RECOMMENDATIONS

The GAINR-coupled system did not provide sufficient fidelity to allow pilots to discern sufficient sound azimuth and elevation for operational utility. Forward and aft cues were ambiguous and difficult to differentiate by the pilots. The ability of the Head Tracker-coupled 3D Audio system to provide continuous and accurate cues to the pilot was limited by the angular accuracy of the inertial Head Tracker. Forward and aft cue ambiguity was solved by adding a head-tracking system, but the addition of heading drift degraded the overall system performance.

The following conclusions and recommendations are presented in priority order for mission suitability.

Although the current version of the 3D Audio system under test met satisfactory evaluation criteria in only two areas, the system has significant potential to increase pilot situational awareness and should be investigated further. Pilots were able to discern attitude and azimuth heading information using audio cues, showing promise for use in an aviation application.

Continue to develop, test, and evaluate 3D Audio technology for use in flight (R8, page 12).

The Head Tracker system demonstrated that a low cost MEMS IMU can provide attitude information. Continued development of the system to include further tuning of the Kalman filter, the use a higher quality IMU, investigation of different INS mechanizations schemes, or the use of higher order state models may provide the needed angular accuracy.

Continue to develop, test, and evaluate MEMS IMU technology for the use of inertial head tracking (R7, page 12).

Inertial Head Tracker heading accuracy was unsatisfactory. Head Tracker accuracy decreased during maneuvers with little or no lateral acceleration. Cruise flight requires a significant amount of straight-and-level flight, but the poor performance of the Head Tracker under these conditions will lead to inadequate 3D Audio performance.

Improve inertial Head Tracker angular accuracy (R1, page 5).

The 3D audio system could not be used to precisely discern a commanded heading within ± 10 degrees in 90 percent of the trials. Incorrect headings were flown while following 3D Audio cues.

Increase the precision of the 3D Audio cues near the commanded heading (R3, page 8).

The 3D Audio system did not provide consistently discernable elevation cues, and the addition of the Head Tracker did not improve performance over the GAINR-coupled

configuration. Applications such as collision avoidance systems and directional communications require accurate elevation information.

Improve elevation performance of the 3D Audio system (R2, page 7).

Pilots were unaware of approaching roll and/or pitch limits. Adding an audio cue when the aircraft is approaching limits would prevent the pilot from overcorrecting from deviations.

Add an audio indication when approaching a preset attitude limit (R5, page 11).

The present system provides no altitude information to the pilot and the slightest pitch deviation from level flight could cause large altitude deviations over time. For example a two degree pitch deviation from level flight at 200 KTAS will lead to a 700 foot altitude deviation in one minute.

Add an audio indication of altitude (R6, page 11).

The pilots found that depending on the frequency content of the audio horizon music, the bass/treble pitch response was either improved or degraded. This could potentially affect the performance of the audio horizon cue in any configuration of the 3D Audio system.

Investigate the effects of the frequency content of the music used for the audio horizon cue (R4, page 9).

REFERENCES

1. Tran, Luan, *GAINR-GLite System Installation Package*, JT3, LLC, Air Force Flight Test Center, Edwards AFB, CA, 14 June 2004.
2. Flight Manual, USAF Series Aircraft, C-12C, Technical Order 1C-12A-1, HEBCO, Inc., 1 November 2003.
3. Taschner, Michael J., Lieutenant Colonel, USAF, *Modification Flight Manual: C-12C, Serial Number 73-1215*, Air Force Flight Test Center, Edwards AFB CA, 23 September 2002.
4. Gawell, Lynnette J.F, Major, USAF, *Modification Operational Supplement: C-12C, Serial Number 73-1215*, Air Force Flight Test Center, Edwards AFB CA, 31 August 2004.
5. Joffrion, Jacque M., Captain, USAF, et al., *Inertial Head Tracking for 3D Audio (Project "Sound Advice") Test Plan*, USAF TPS-TP-04A-04, USAF Test Pilot School, Edwards AFB CA, October 2004.
6. Federal Aviation Regulation Part 91, Section 177, Paragraph a2, *Minimum Altitudes for IFR Operations*, Federal Aviation Administration, Department of Transportation, 18 February 2004.



APPENDIX A – DETAILED TEST ARTICLE DESCRIPTION

The inertial Head Tracker consisted of a microelectromechanical system (MEMS) inertial measurement unit (IMU), a Garmin GPS receiver, a DC/AC power inverter, and a laptop computer. All inertial Head Tracker equipment was provided by AFIT/ENG.

The integrated 3D Audio system consisted of a stereo headset, audio mixer, and a laptop computer provided by AFRL/HECB. The 3D Audio system provided audio cues to the evaluation pilot. The angular orientation of the evaluation pilot's head was obtained from the inertial Head Tracker system and input to the 3D Audio system. Audio from the aircraft intercom system was mixed with audio cues from the 3D Audio system. The 3D audio system used recorded music for the audio horizon cue. The chosen music for each pilot is listed in Table A-1.

Table A-1. Selected Music for 3D Audio Horizon Cue

Pilot 1	Pilot 2	Pilot 3
Third Day™ – Offerings	Evanescence™ – Fallen	Dido™ – No Angel

The test support hardware consisted of a GPS Aided Inertial Reference (GAINR) system as the primary source of truth data (Reference 1) and the C-12C aircraft data acquisition system (DAS) instrumentation. All test support hardware was supplied by Edwards AFB range (412 TW/ENR) and special instrumentation (USAF TPS/TS) personnel.

A single C-12C Huron test aircraft, tail # 73-1215, was used to collect data for this analysis. The C-12C was a Raytheon King Air twin-engine turboprop transport aircraft. A detailed description of the C-12C was found in the C-12C Flight Manual (Reference 2). Detailed descriptions of aircraft modifications were found in the Modification Flight Manual (MFM) (Reference 3) and Modification Operational Supplement (MOS) (Reference 4).

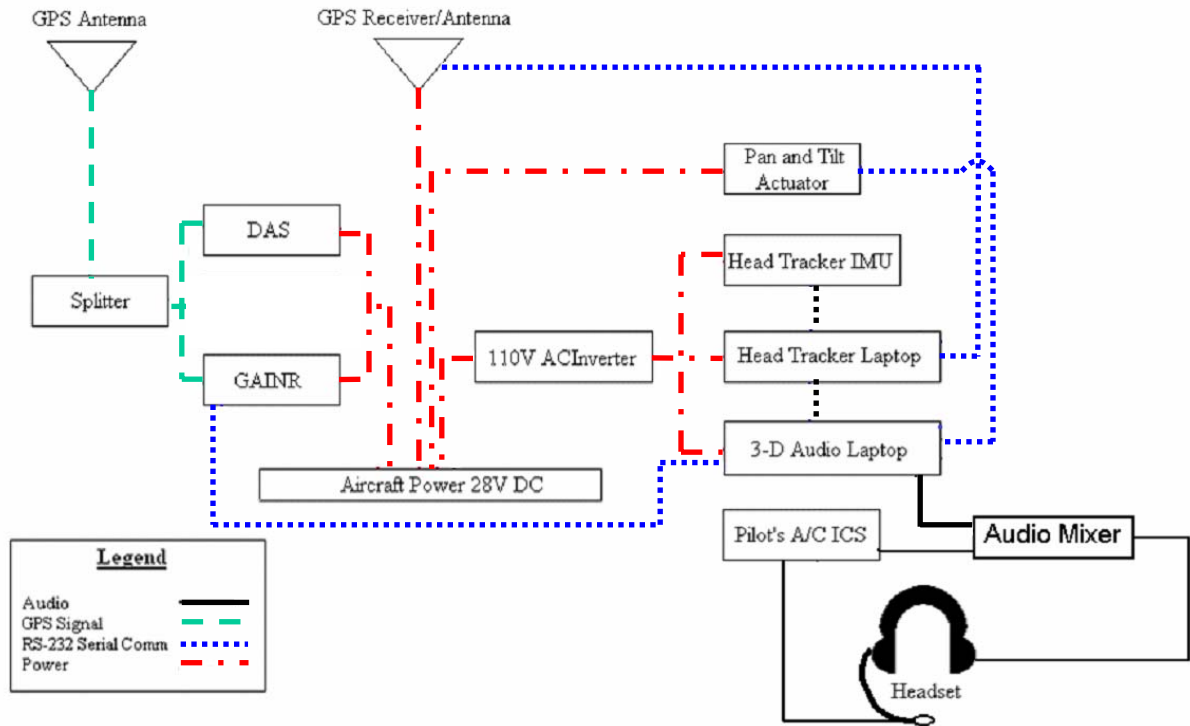

Figure A-1. C-12C Tail # 73-1215 Test and Support Hardware

APPENDIX B – TEST SUMMARY AND MANEUVER SET

Table B-1. Sound Advice Test Summary

Date	Sortie #	Sortie Time (hrs)	3D Audio Configuration	Eval Pilot #	Measure of Performance Tasks Completed
14 Oct 04	1	1.1	-	1, 3	Kalman Filter Parameters
19 Oct 04	2	2.0	GAINR-Coupled	3	Ground Localization Airborne Localization Heading Cue
21 Oct 04	3	1.9	GAINR-Coupled	1	Airborne Localization Heading Cue Change in Attitude Threshold Straight/Level Flight
22 Oct 04	4	1.4	GAINR-Coupled	2	Ground Localization Airborne Localization Heading Cue Change in Attitude Threshold Straight/Level Flight
25 Oct 04	5	2.0	GAINR-Coupled	3	Change in Attitude Threshold Straight/Level Flight
			-	2, 3	Head Tracker Angular Accuracy (fixed to aircraft body)
26 Oct 04	6	2.2	GAINR-Coupled	1	Ground Localization
			Head Tracker-Coupled + Higher Gains	2	Ground Localization Airborne Localization Heading Cue Change in Attitude Threshold
1 Nov 04	7	2.9	Head Tracker-Coupled + Higher Gains	3	Ground Localization Airborne Localization Heading Cue Change in Attitude Threshold Straight/Level Flight
				2	Straight/Level Flight
				1	Ground Localization Airborne Localization
2 Nov 04	8	1.9	Head Tracker-Coupled + Higher Gains	1	Heading Cue Change in Attitude Threshold Straight/Level Flight
8 Nov 04	-	-	Head Tracker-Coupled + Higher Gains	1, 2, 3	Baseline Indoor Localization

Table B-2. C-12C Aircraft Maneuver Set for Inertial Head Tracker Angular Accuracy

Maneuver	Nominal Conditions	Remarks	Prop rpm
Climbs	150 KIAS	Δ Alt of at least 2000 ft	1900
Straight and Level Unaccelerated Flight*	170 KIAS, 12,000 ft	TOL: ± 4 kts, ± 100 ft	1700
Constant G Turns*	170 KIAS, 12,000 ft	Data band 20° - 60° of bank TOL: $\pm 5^\circ$ AOB, ± 200 ft, ± 4 kts	1700
Steady Heading Side Slips (SHSS)* Limit to 8° of Beta (1/2 rudder pedal deflection if DAS not available)	170 KIAS, 12,000 ft	TOL: ± 5 kts Steady heading sideslips will be terminated at first indication of rudder force lightening.	1700
Level Accelerations	12,000 ft	TOL: ± 100 ft	1700
Level Decelerations	12,000 ft	TOL: ± 100 ft	1700
Roller Coasters	170 KIAS	Load factors to 80% of the Flight Manual G limits	1700
Yoke Raps	170 KIAS, 12,000 ft		1700
Pitch/Rudder Doublets	170 KIAS, 12,000 ft	No Yaw frequency sweeps	1700
30° to 30° Bank-to-Bank Rolls	170 KIAS, 12,000 ft	TOL: ± 1000 ft	1700
Descents	150 KIAS	Δ Alt of at least 2000 ft	1700

APPENDIX C – DATA

DATA BASIS: Flight Test	Test A/C: C-12C SN#73-1215	Test Dates: 14 Oct – 2 Nov 04
Weights: 10.000 lb – 12.500 lb	Airspeeds: 150-190 KIAS	Altitude: 10-14k ft

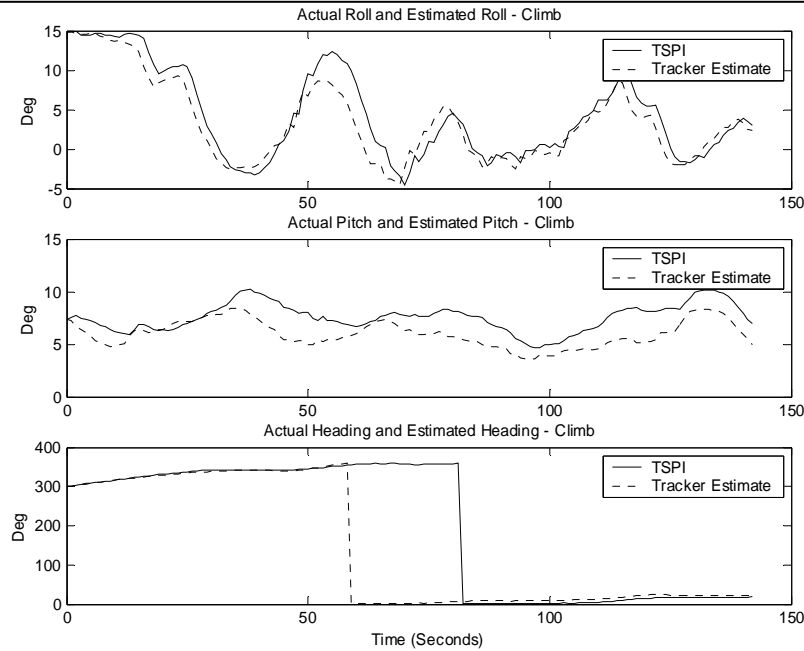

Figure C-1. Head Tracker Angular Performance in Climb

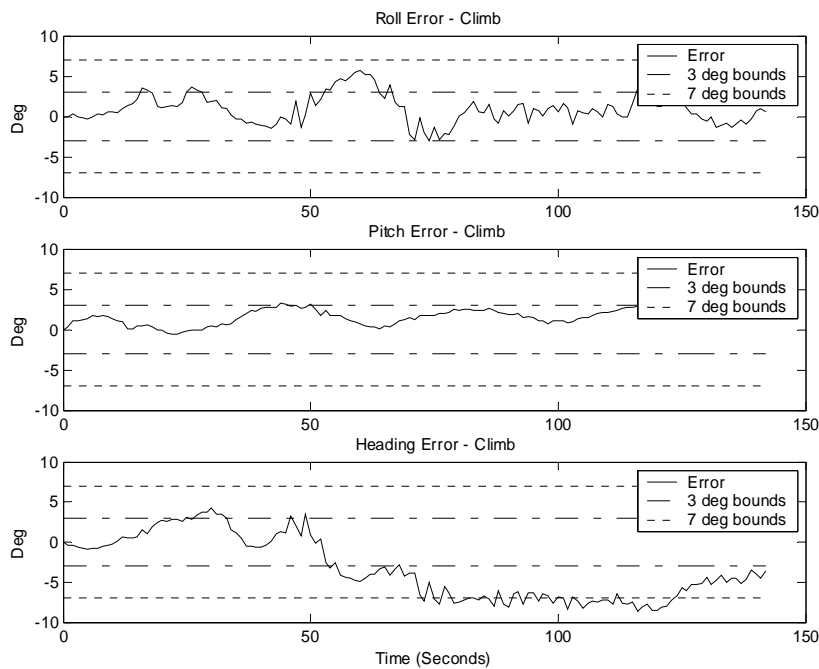

Figure C-2. Head Tracker Angular Accuracy in Climb

DATA BASIS: Flight Test Test A/C: C-12C SN#73-1215 Test Dates: 14 Oct – 2 Nov 04
Weights: 10,000 lb – 12,500 lb Airspeeds: 150-190 KIAS Altitude: 10-14k ft

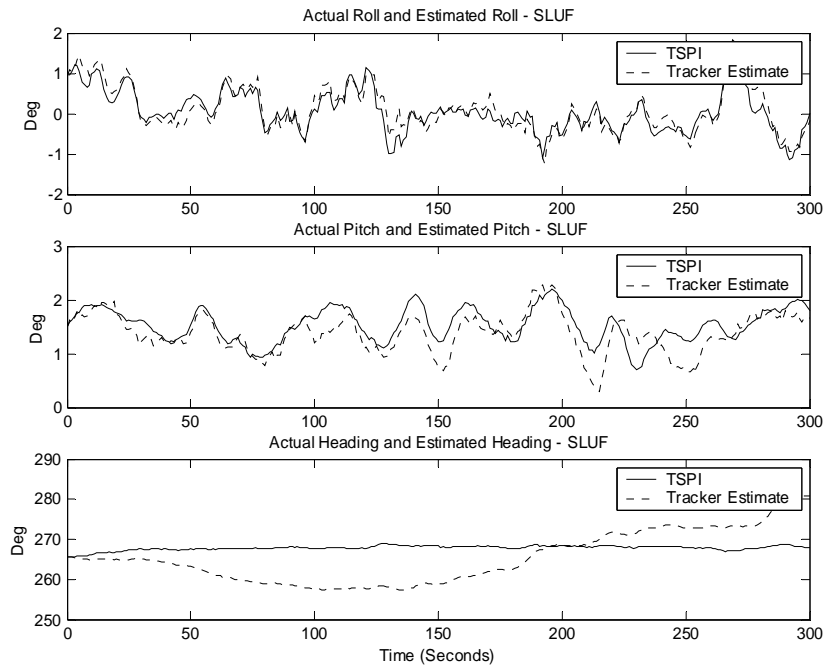

Figure C-3. Head Tracker Angular Performance in Straight & Level Unaccelerated Flight

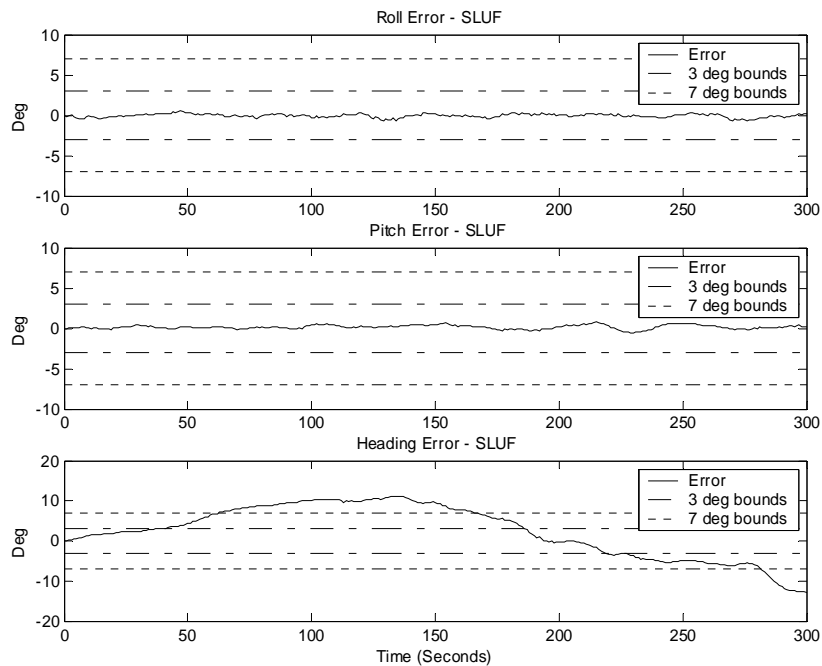

Figure C-4. Head Tracker Angular Accuracy in Straight & Level Unaccelerated Flight

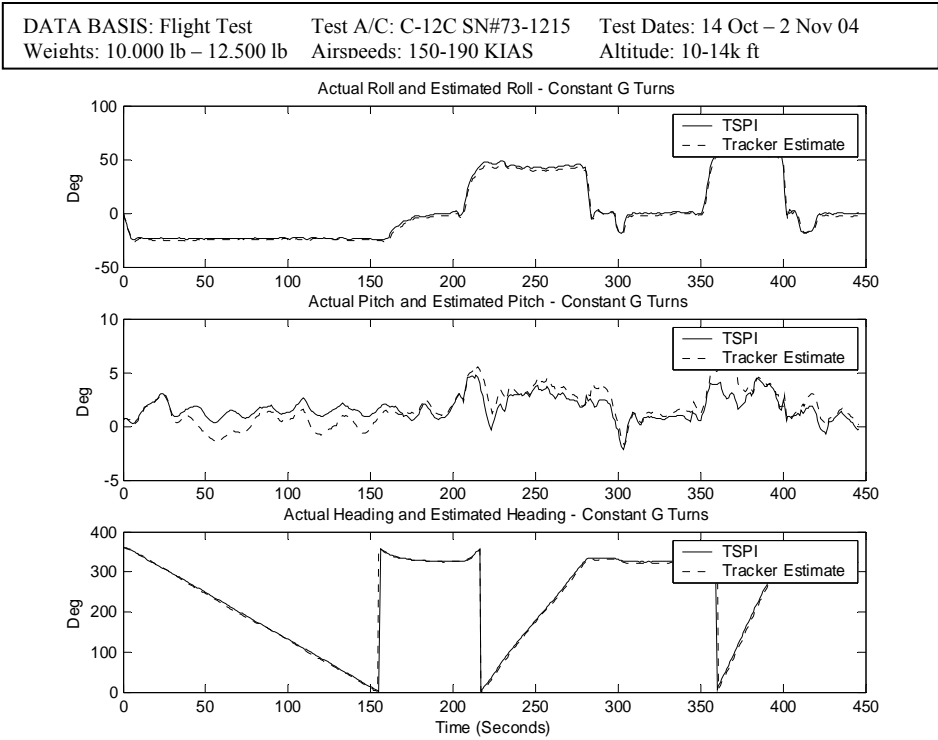

Figure C-5. Head Tracker Angular Performance in Constant G Turn

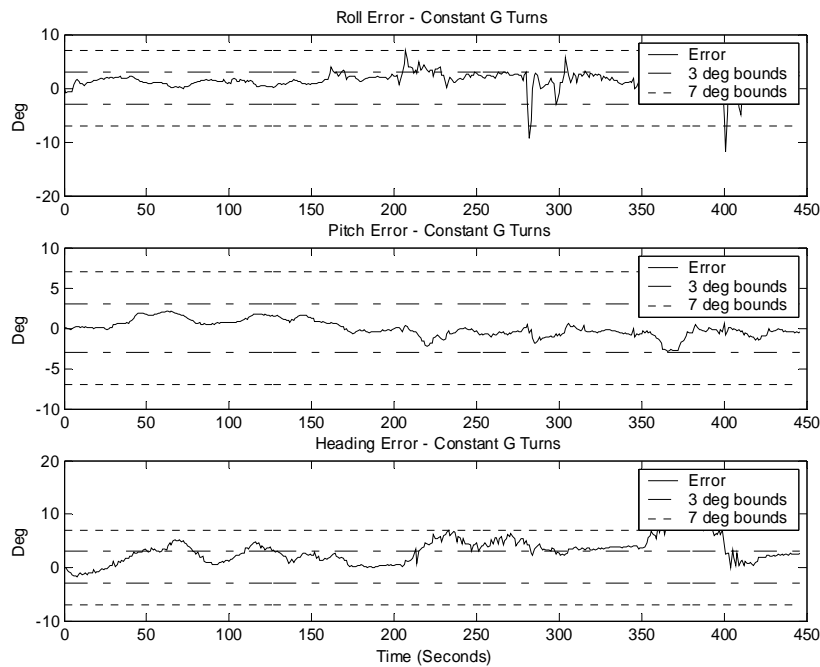

Figure C-6. Head Tracker Angular Accuracy in Constant G Turn

DATA BASIS: Flight Test Test A/C: C-12C SN#73-1215 Test Dates: 14 Oct – 2 Nov 04
Weights: 10,000 lb – 12,500 lb Airspeeds: 150-190 KIAS Altitude: 10-14k ft

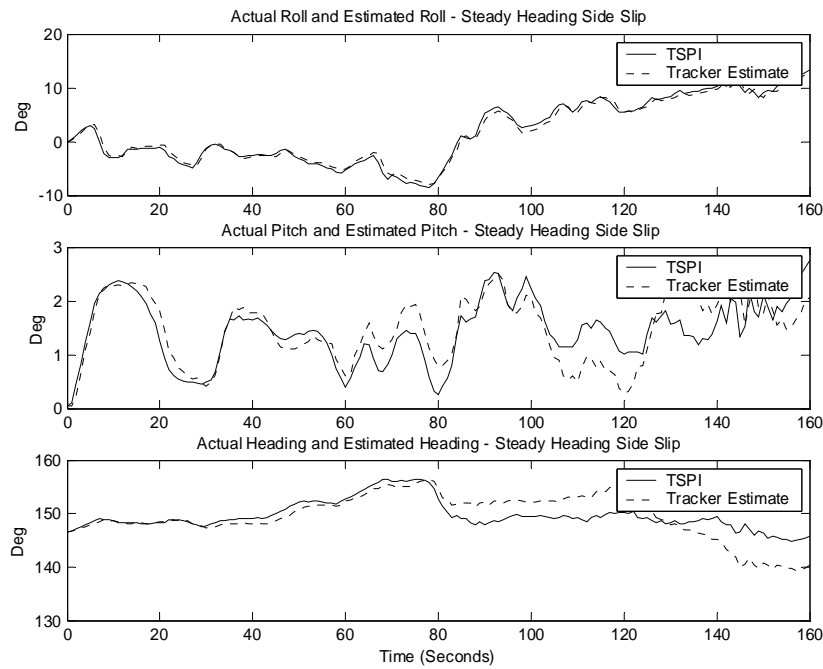

Figure C-7. Head Tracker Angular Performance in Steady Heading Side Slip

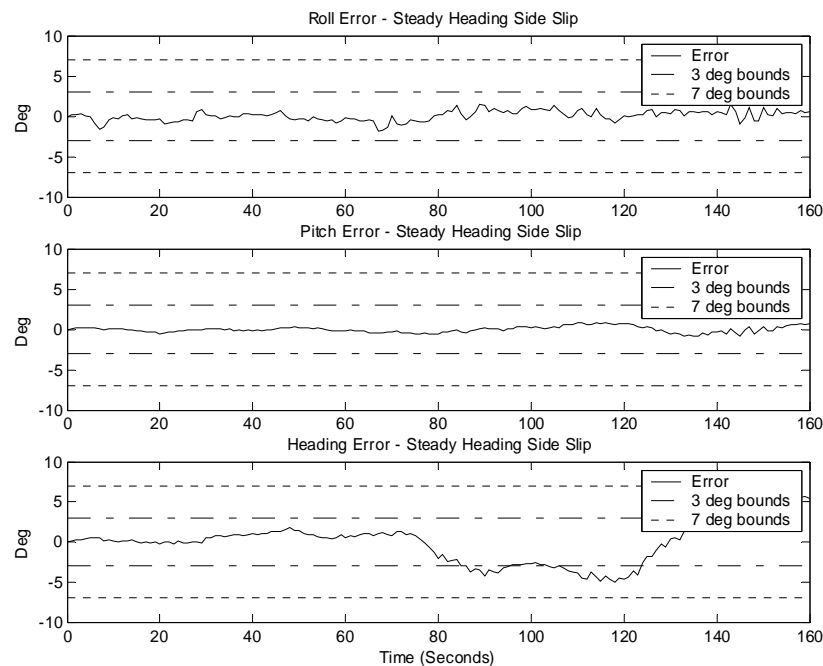

Figure C-8. Head Tracker Angular Accuracy in Steady Heading Side Slip

DATA BASIS: Flight Test Test A/C: C-12C SN#73-1215 Test Dates: 14 Oct – 2 Nov 04
Weights: 10,000 lb – 12,500 lb Airspeeds: 150-190 KIAS Altitude: 10-14k ft

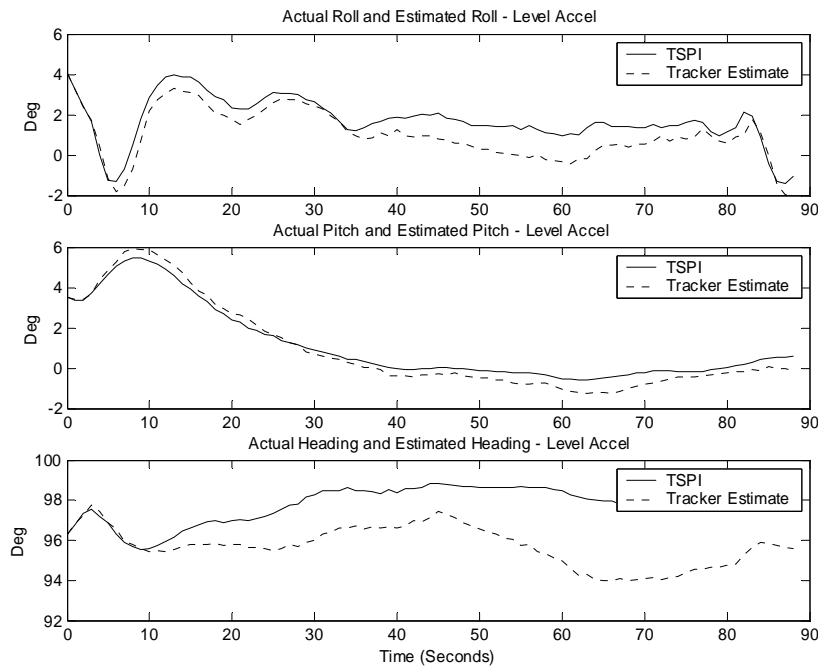

Figure C-9. Head Tracker Angular Performance in Level Acceleration

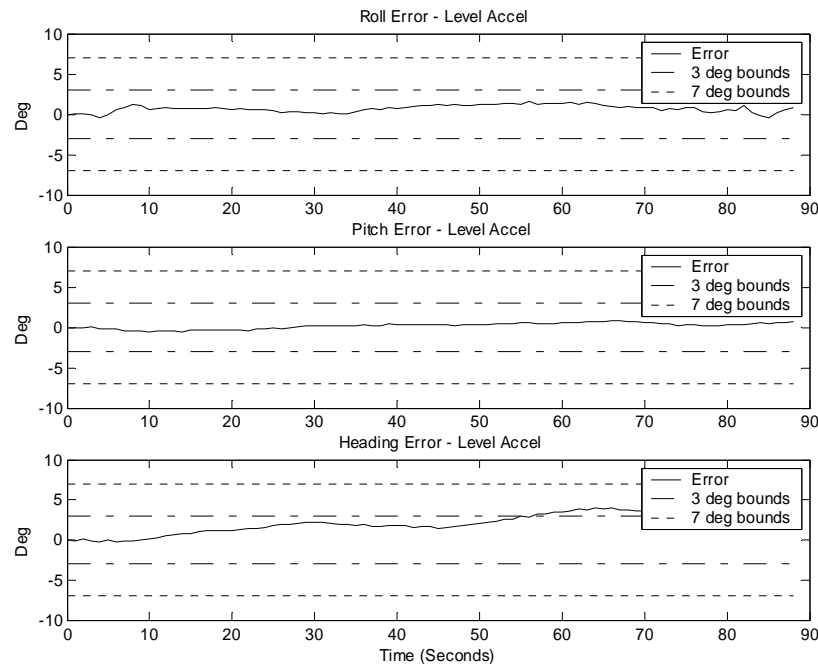

Figure C-10. Head Tracker Angular Accuracy in Level Acceleration

DATA BASIS: Flight Test Test A/C: C-12C SN#73-1215 Test Dates: 14 Oct – 2 Nov 04
Weights: 10,000 lb – 12,500 lb Airspeeds: 150-190 KIAS Altitude: 10-14k ft

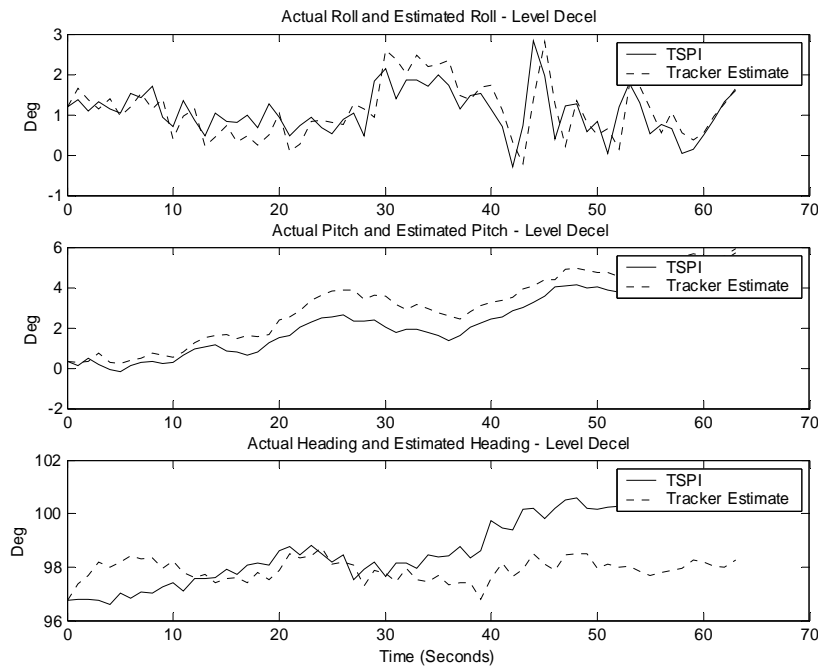

Figure C-11. Head Tracker Angular Performance in Level Deceleration

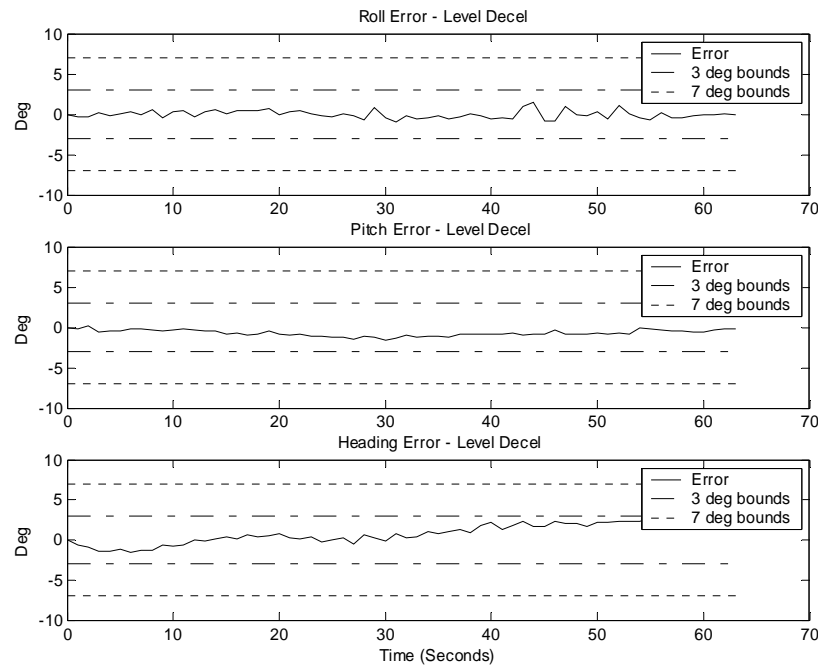

Figure C-12. Head Tracker Angular Accuracy in Level Deceleration

DATA BASIS: Flight Test	Test A/C: C-12C SN#73-1215	Test Dates: 14 Oct – 2 Nov 04
Weights: 10.000 lb – 12.500 lb	Airspeeds: 150-190 KIAS	Altitude: 10-14k ft

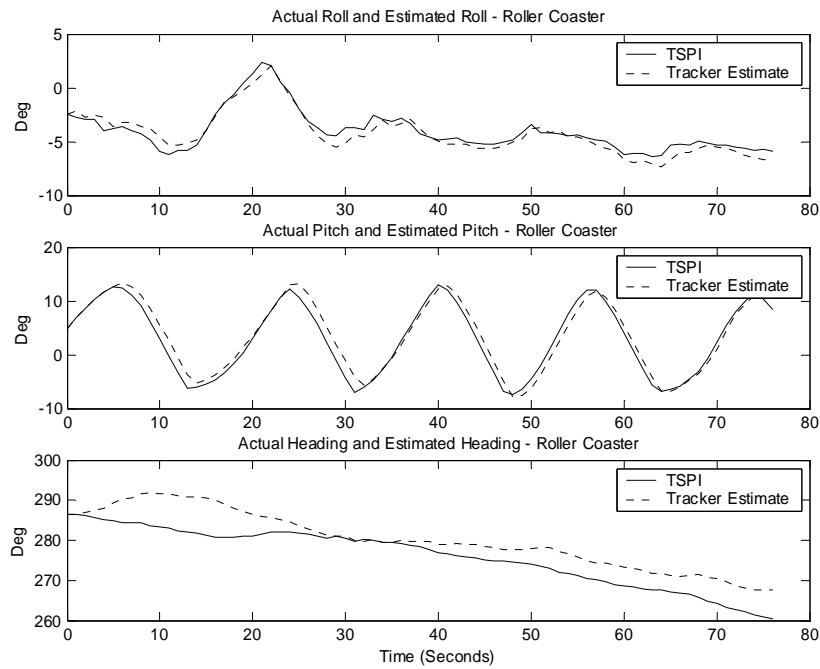

Figure C-13. Head Tracker Angular Performance in Roller Coaster

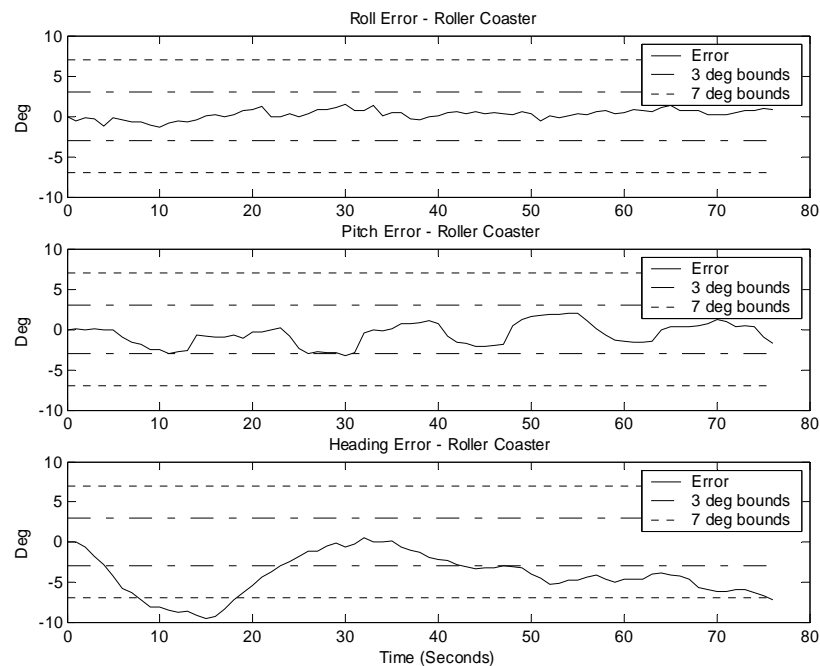

Figure C-14. Head Tracker Angular Accuracy in Roller Coaster

DATA BASIS: Flight Test	Test A/C: C-12C SN#73-1215	Test Dates: 14 Oct – 2 Nov 04
Weights: 10.000 lb – 12.500 lb	Airspeeds: 150-190 KIAS	Altitude: 10-14k ft

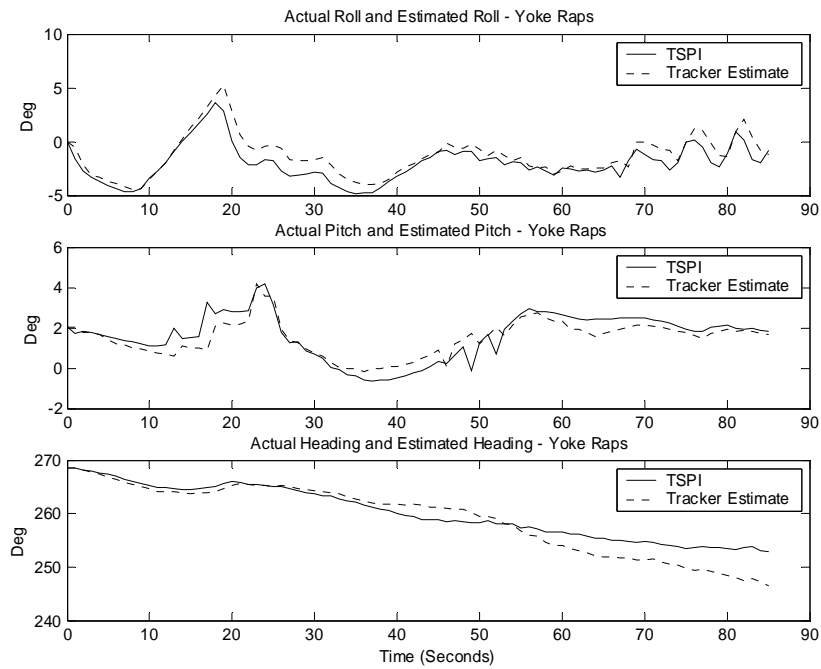

Figure C-15. Head Tracker Angular Performance during Yoke Raps

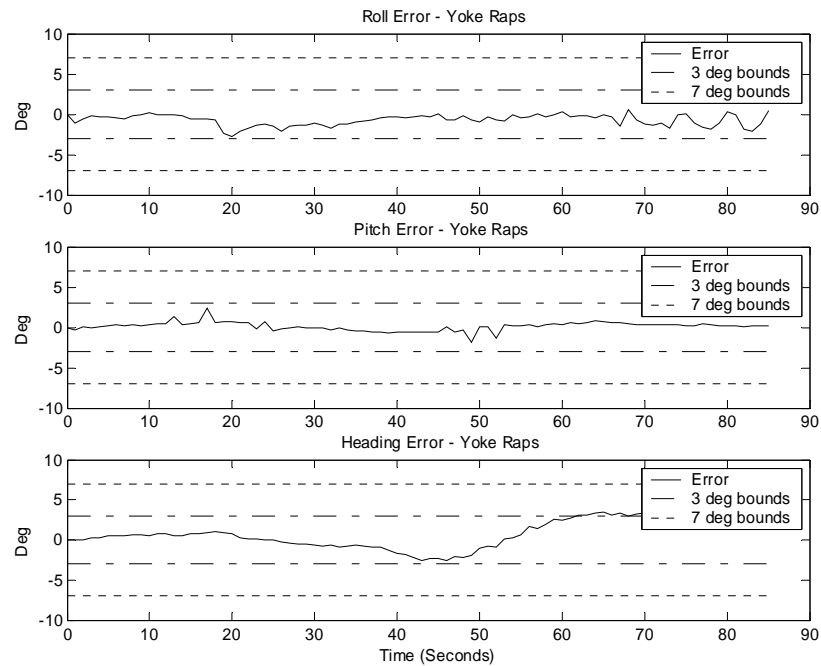

Figure C-16. Head Tracker Angular Accuracy during Yoke Raps

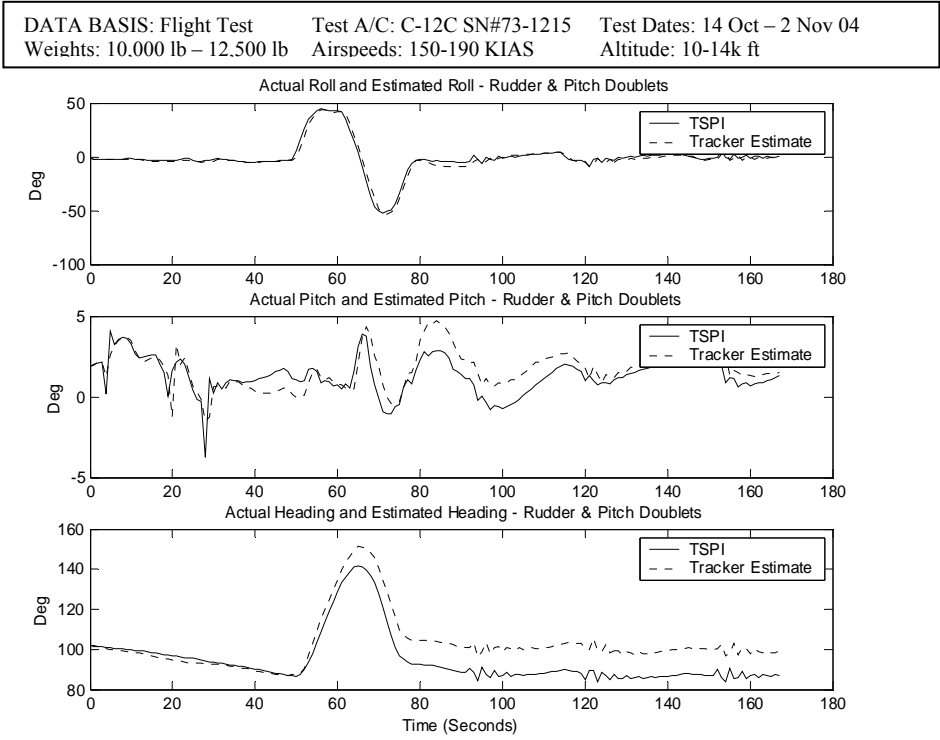

Figure C-17. Head Tracker Angular Performance during Pitch/Rudder Doublets

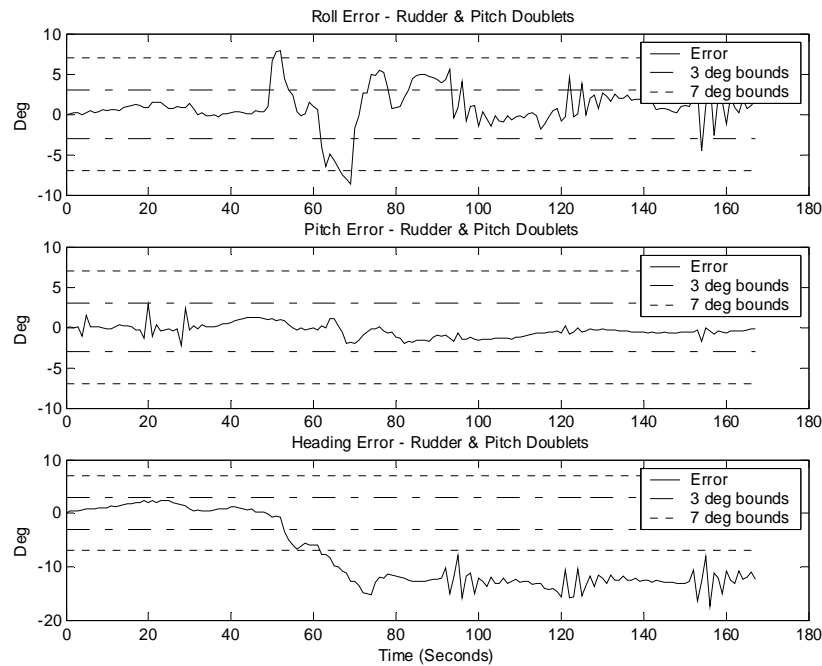

Figure C-18. Head Tracker Angular Accuracy during Pitch/Rudder Doublets

DATA BASIS: Flight Test	Test A/C: C-12C SN#73-1215	Test Dates: 14 Oct – 2 Nov 04
Weights: 10,000 lb – 12,500 lb	Airspeeds: 150-190 KIAS	Altitude: 10-14k ft

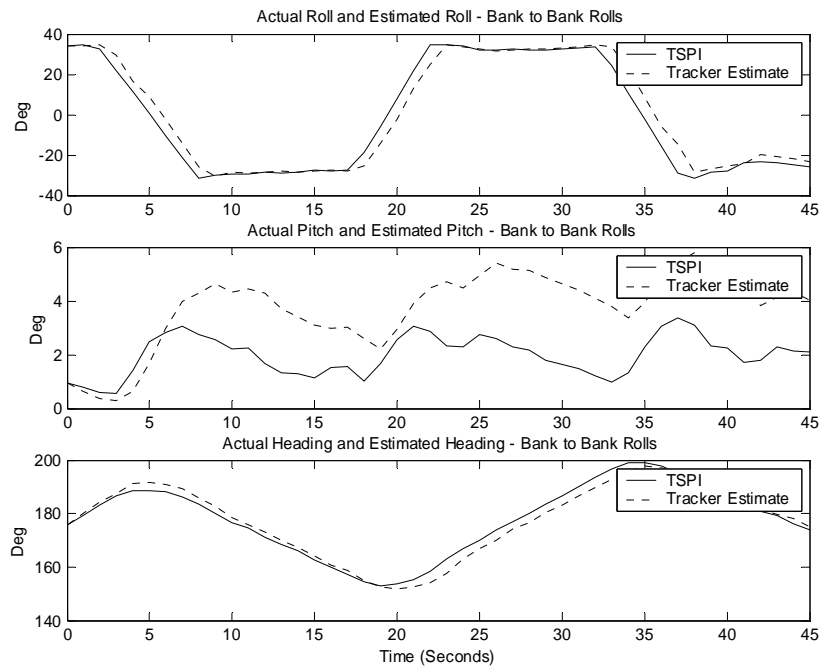

Figure C-19. Head Tracker Angular Performance in 30°-30° Angle-of-Bank Rolls

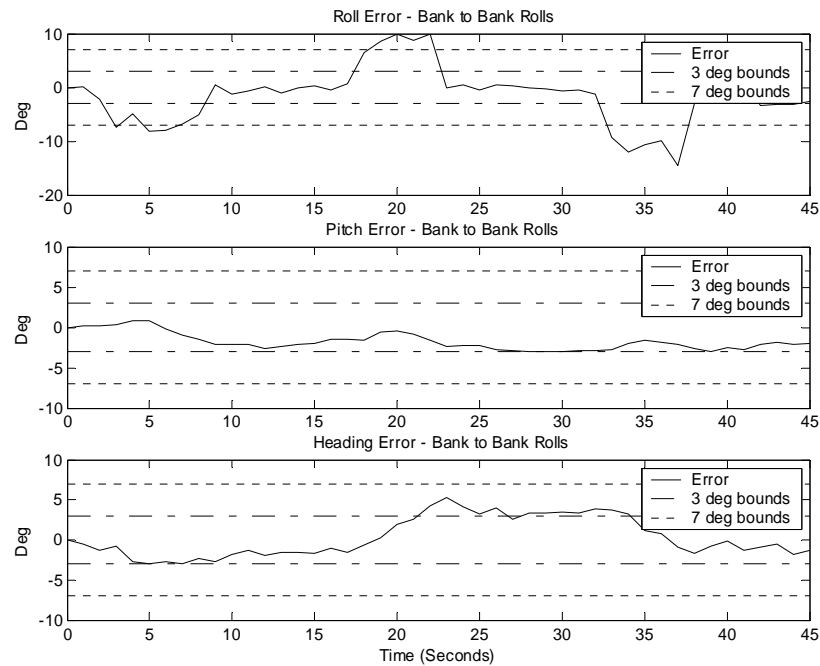

Figure C-20. Head Tracker Angular Accuracy in 30°-30° Angle-of-Bank Rolls

DATA BASIS: Flight Test	Test A/C: C-12C SN#73-1215	Test Dates: 14 Oct – 2 Nov 04
Weights: 10,000 lb – 12,500 lb	Airspeeds: 150-190 KIAS	Altitude: 10-14k ft

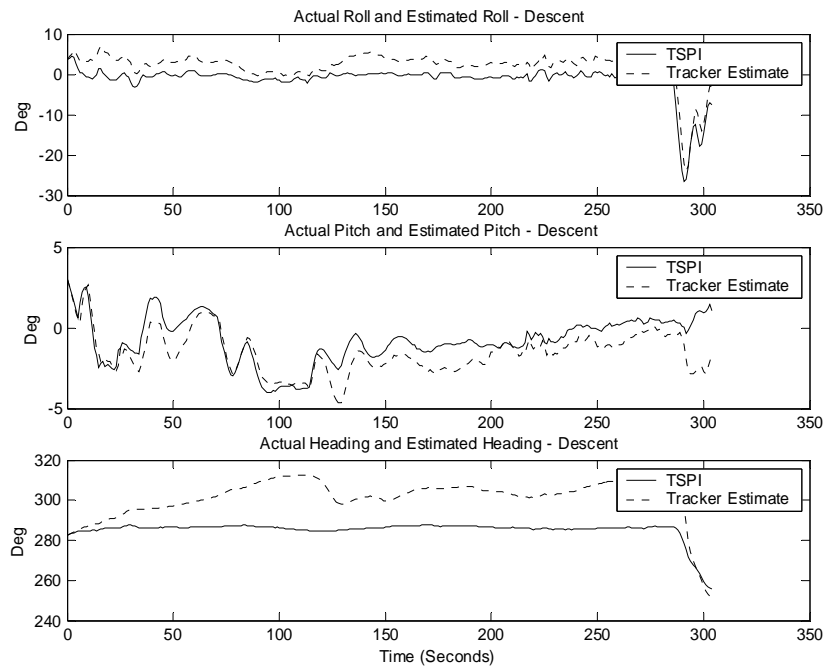

Figure C-21. Head Tracker Angular Performance in Descent

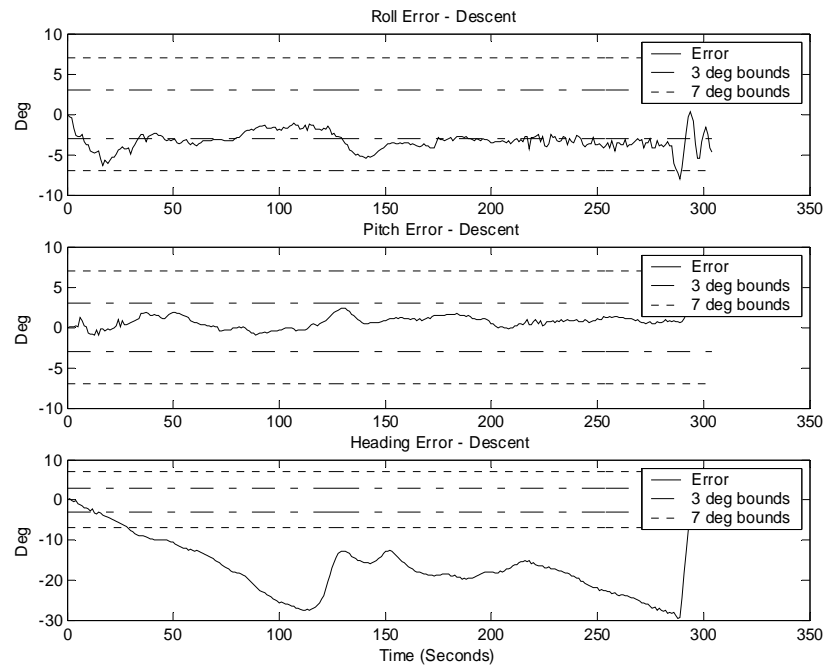

Figure C-22. Head Tracker Angular Accuracy in Descent

DATA BASIS: Flight Test Test A/C: C-12C SN#73-1215 Test Dates: 14 Oct – 2 Nov 04
Weights: 10,000 lb – 12,500 lb Airspeeds: 150-190 KIAS Altitude: 10-14k ft

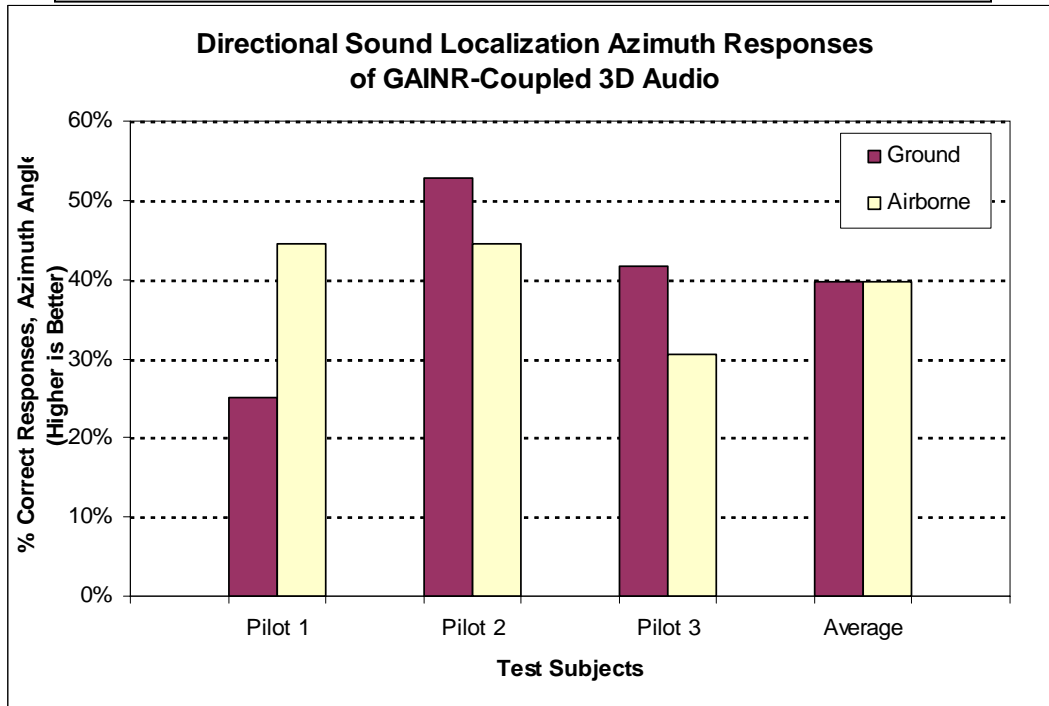

Figure C-23. GAINR-Coupled Localization Azimuth Response Percentages

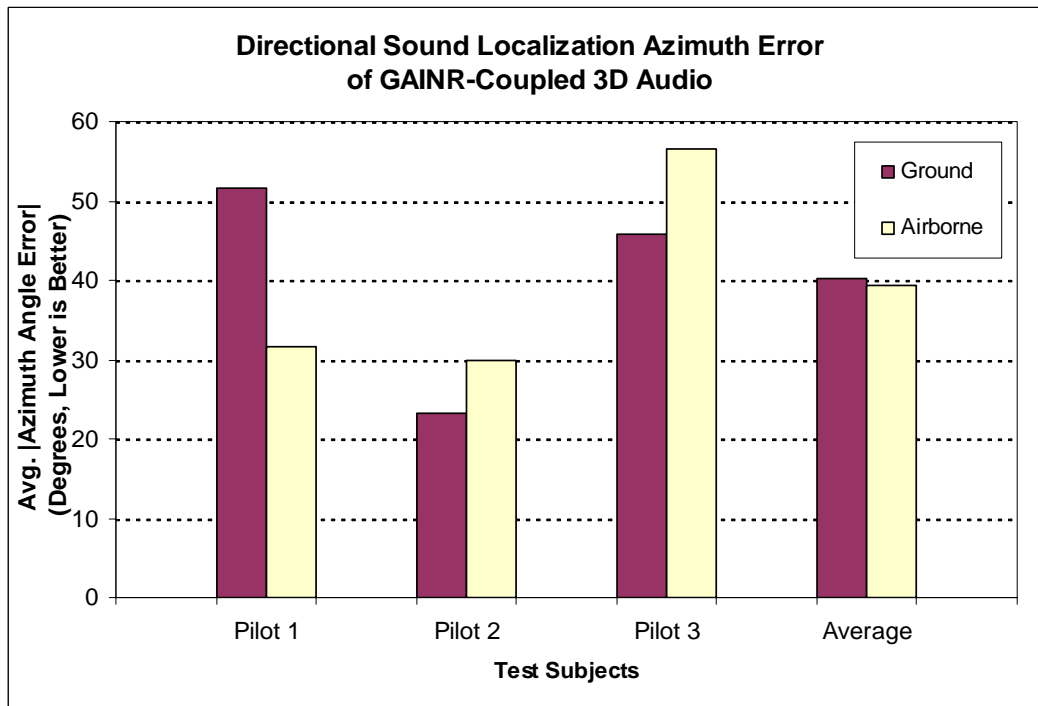

Figure C-24. GAINR-Coupled Localization Azimuth Error

DATA BASIS: Flight Test Test A/C: C-12C SN#73-1215 Test Dates: 14 Oct – 2 Nov 04
Weights: 10,000 lb – 12,500 lb Airspeeds: 150-190 KIAS Altitude: 10-14k ft

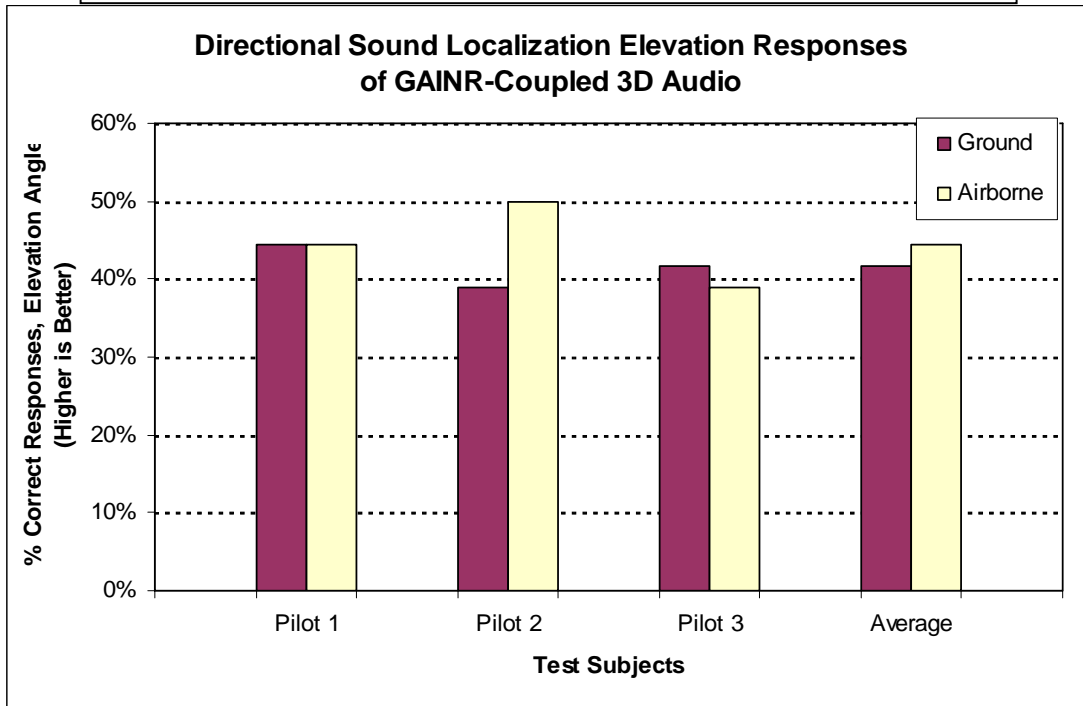

Figure C-25. GAINR-Coupled Localization Elevation Response Percentages

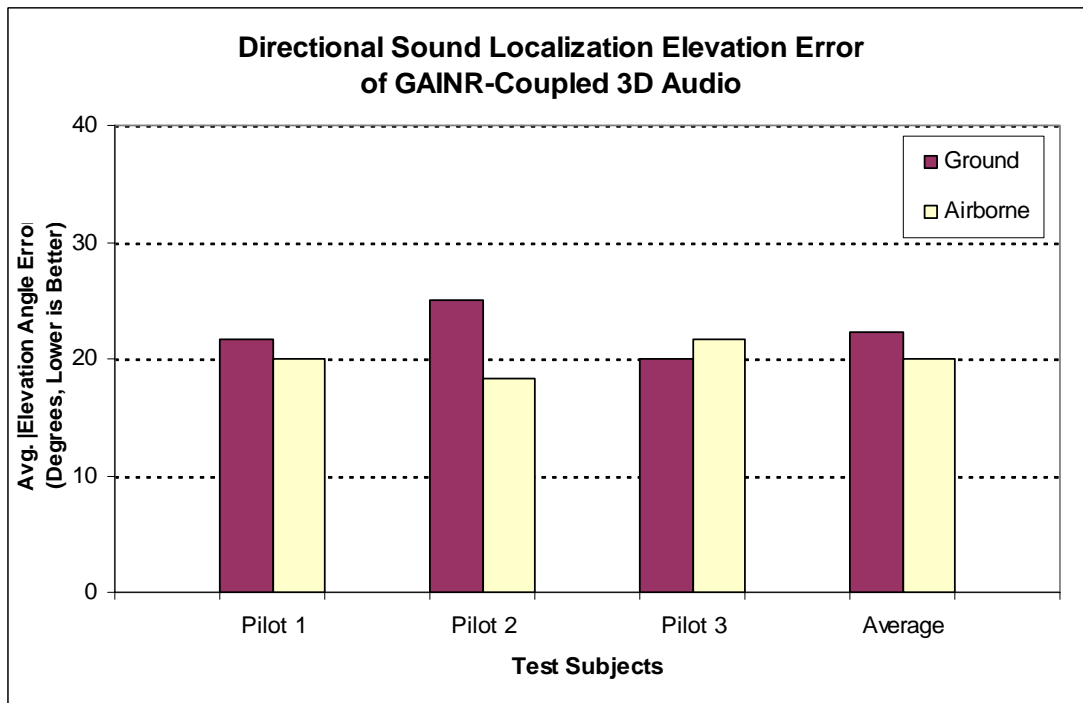

Figure C-26. GAINR-Coupled Localization Elevation Error

DATA BASIS: Flight Test Test A/C: C-12C SN#73-1215 Test Dates: 14 Oct – 2 Nov 04
Weights: 10,000 lb – 12,500 lb Airspeeds: 150-190 KIAS Altitude: 10-14k ft

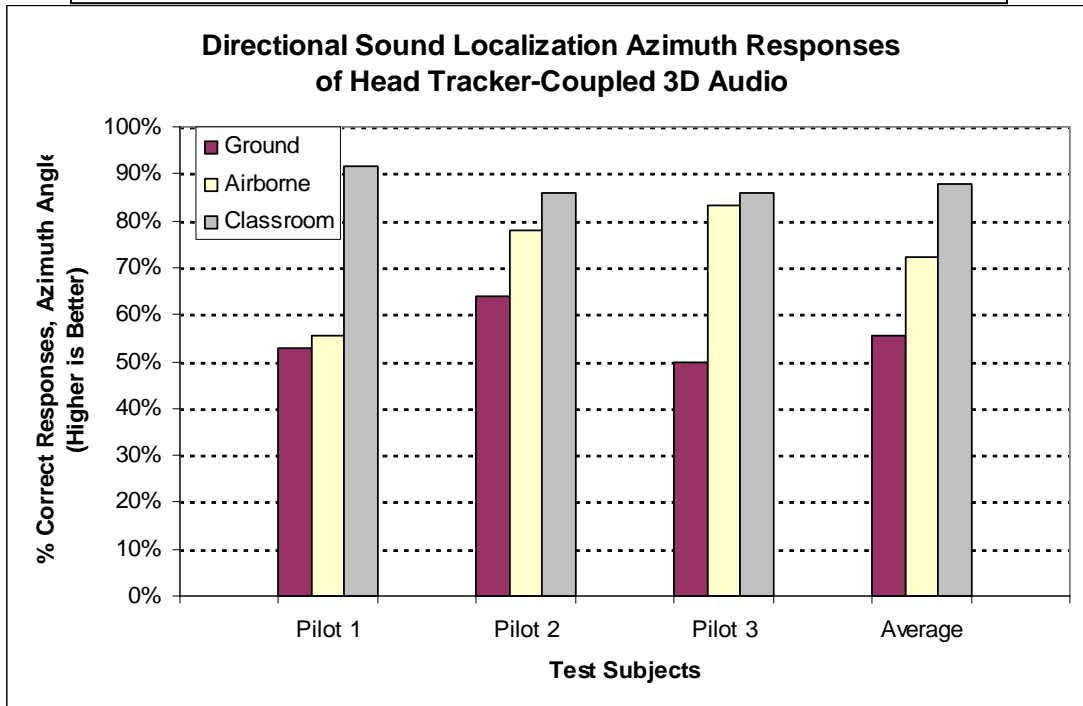

Figure C-27. Head Tracker-Coupled Localization Azimuth Response Percentages

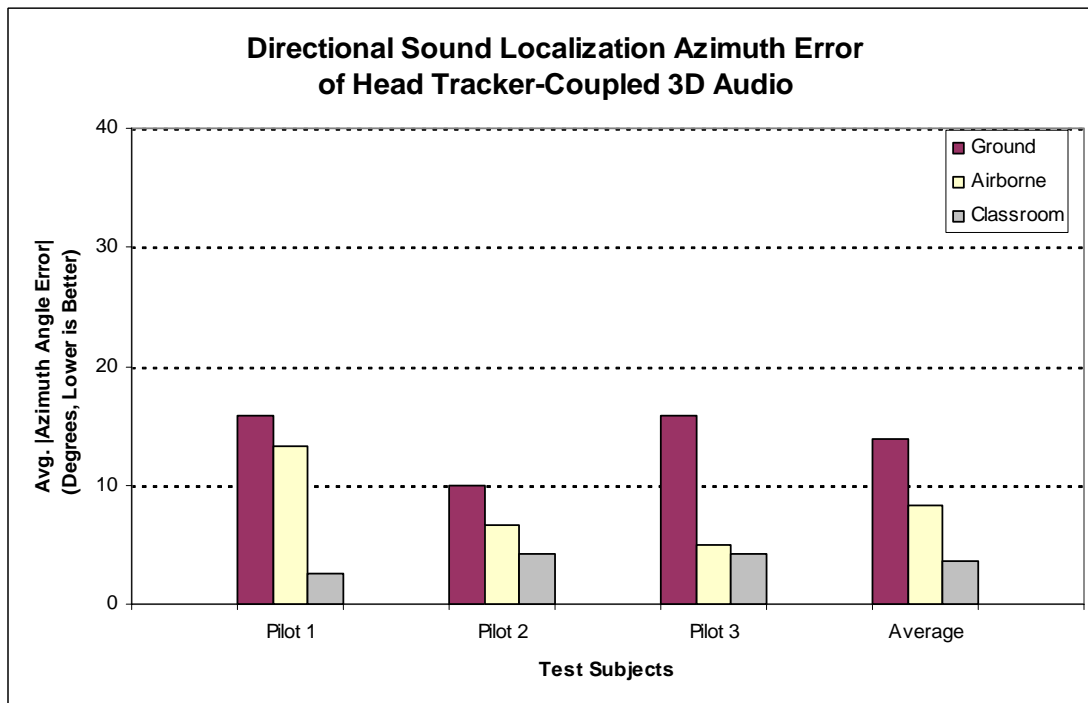

Figure C-28. Head Tracker-Coupled Localization Azimuth Error

DATA BASIS: Flight Test Test A/C: C-12C SN#73-1215 Test Dates: 14 Oct – 2 Nov 04
Weights: 10.000 lb – 12.500 lb Airspeeds: 150-190 KIAS Altitude: 10-14k ft

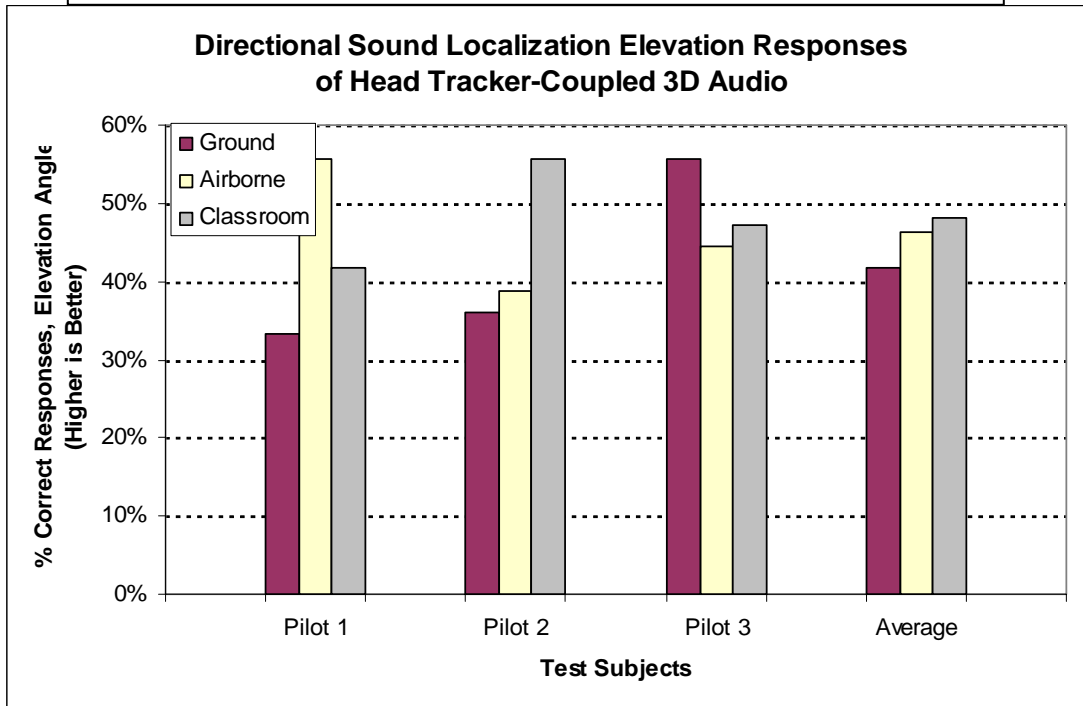

Figure C-29. Head Tracker-Coupled Localization Elevation Response Percentages

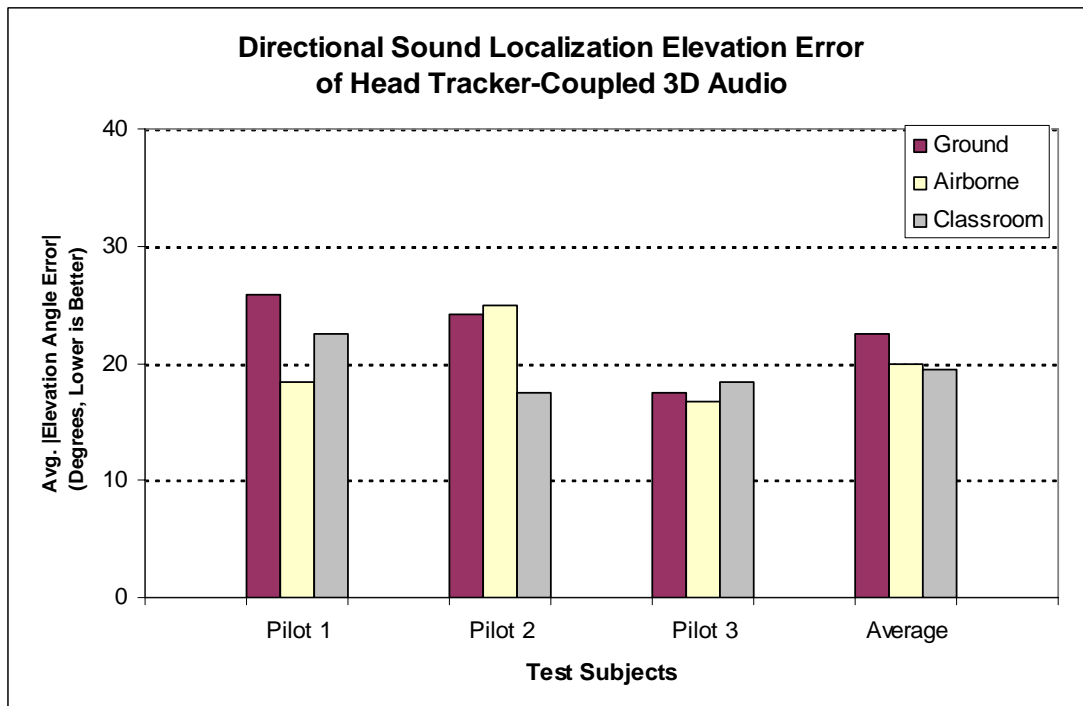

Figure C-30. Head Tracker-Coupled Localization Elevation Error

DATA BASIS: Flight Test Test A/C: C-12C SN#73-1215 Test Dates: 14 Oct – 2 Nov 04
Weights: 10.000 lb – 12.500 lb Airspeeds: 150-190 KIAS Altitude: 10-14k ft

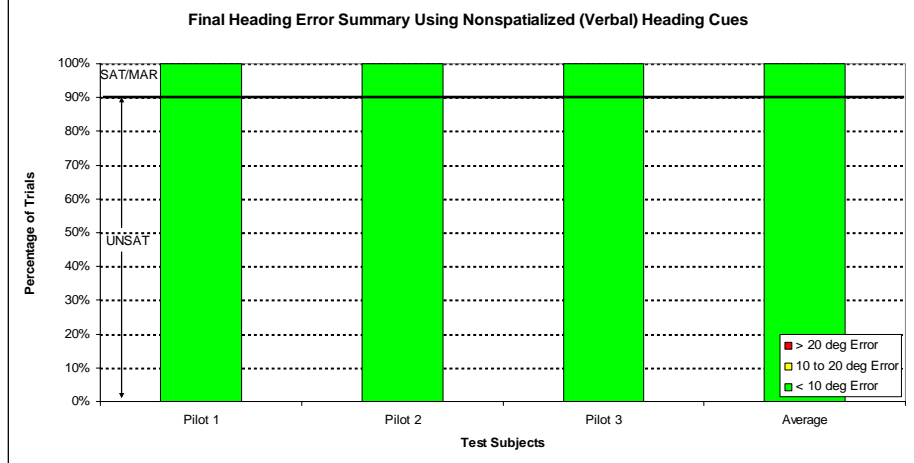

Figure C-31. Baseline Verbal Heading Cue Performance

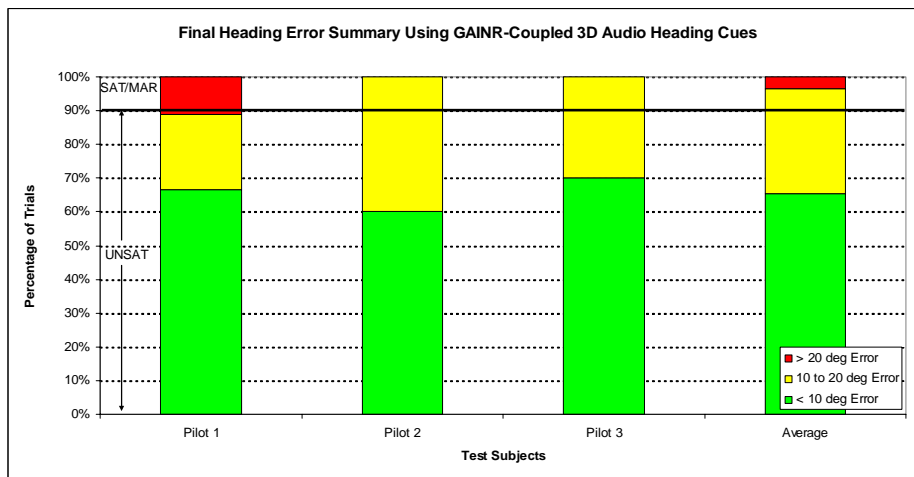

Figure C-32. GAINR-Coupled Heading Cue Performance

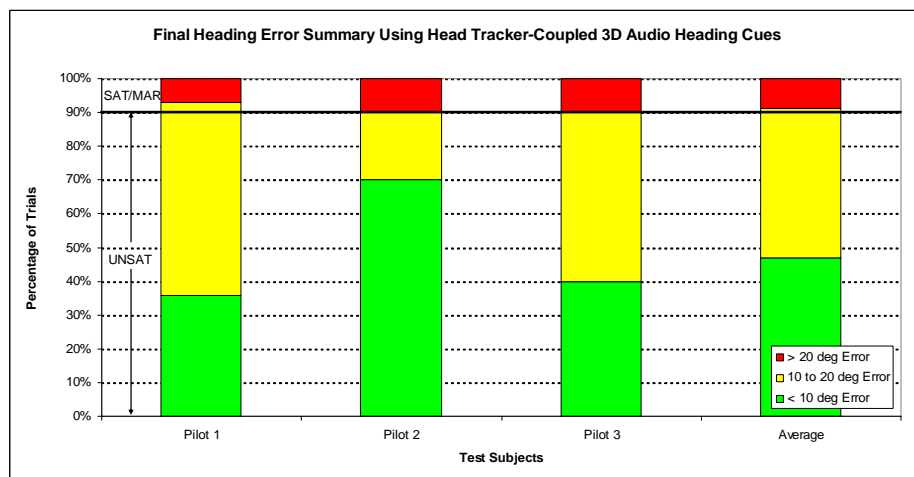

Figure C-33. Head Tracker-Coupled Heading Cue Performance

DATA BASIS: Flight Test	Test A/C: C-12C SN#73-1215	Test Dates: 14 Oct – 2 Nov 04
Weights: 10,000 lb – 12,500 lb	Airspeeds: 150-190 KIAS	Altitude: 10-14k ft

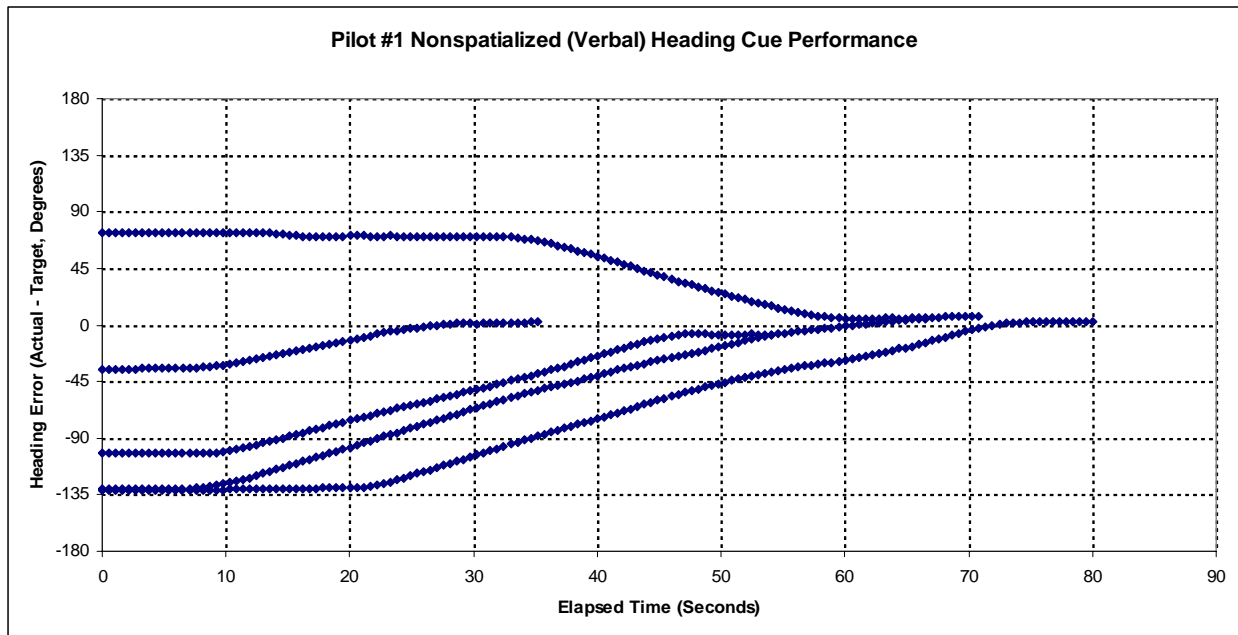

Figure C-34. Pilot #1 Baseline Verbal Heading Cue Performance

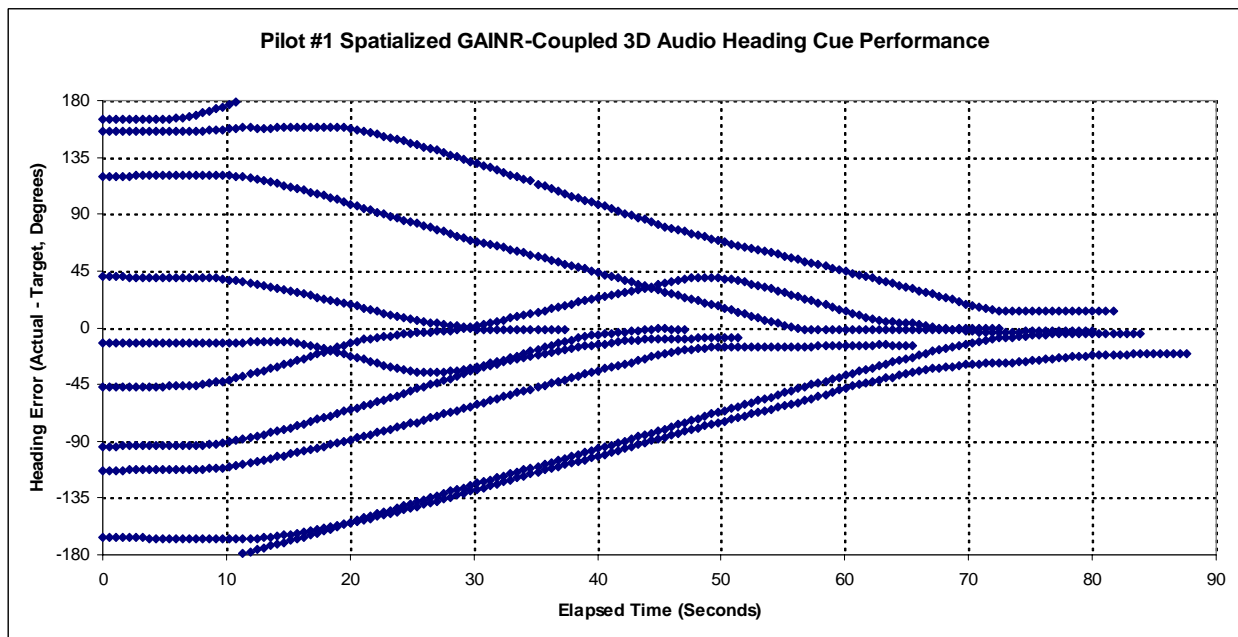

Figure C-35. Pilot #1 GAINR-Coupled 3D Audio Heading Cue Performance

Note: Each curve in Figures C-34 to C-45 represents a single trial, indicating the closure of actual aircraft heading to a random target heading. Overshoots, initial, and final heading error for each trial can be seen on these figures.

DATA BASIS: Flight Test	Test A/C: C-12C SN#73-1215	Test Dates: 14 Oct – 2 Nov 04
Weights: 10,000 lb – 12,500 lb	Airspeeds: 150-190 KIAS	Altitude: 10-14k ft

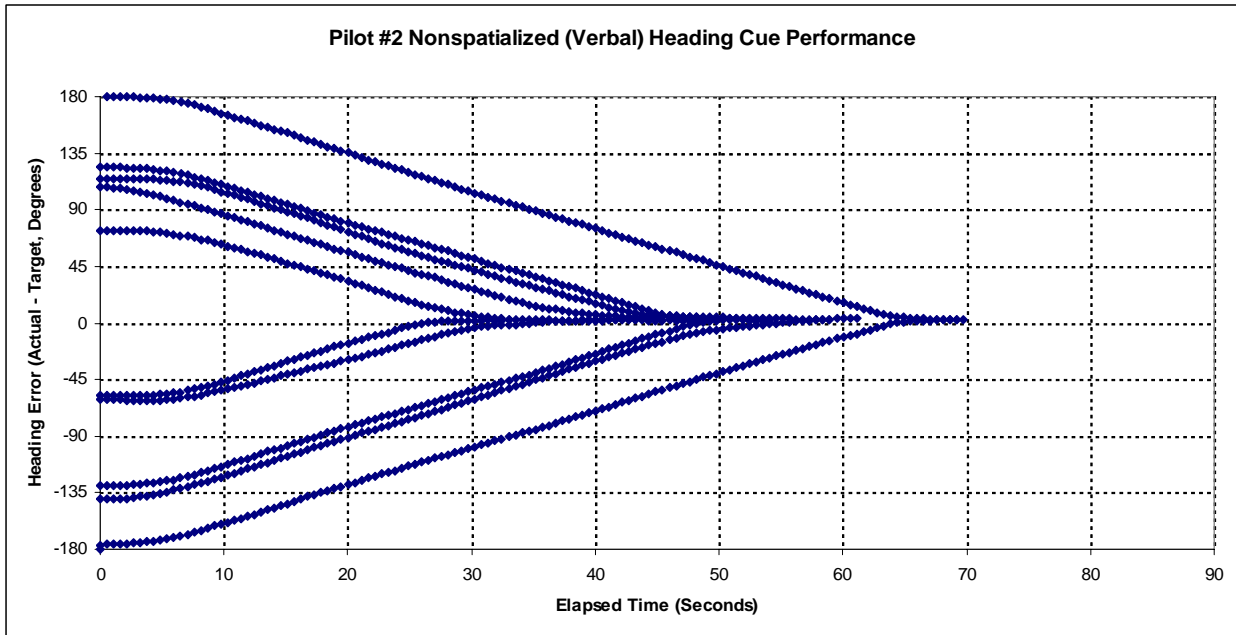

Figure C-36. Pilot #2 Baseline Verbal Heading Cue Performance

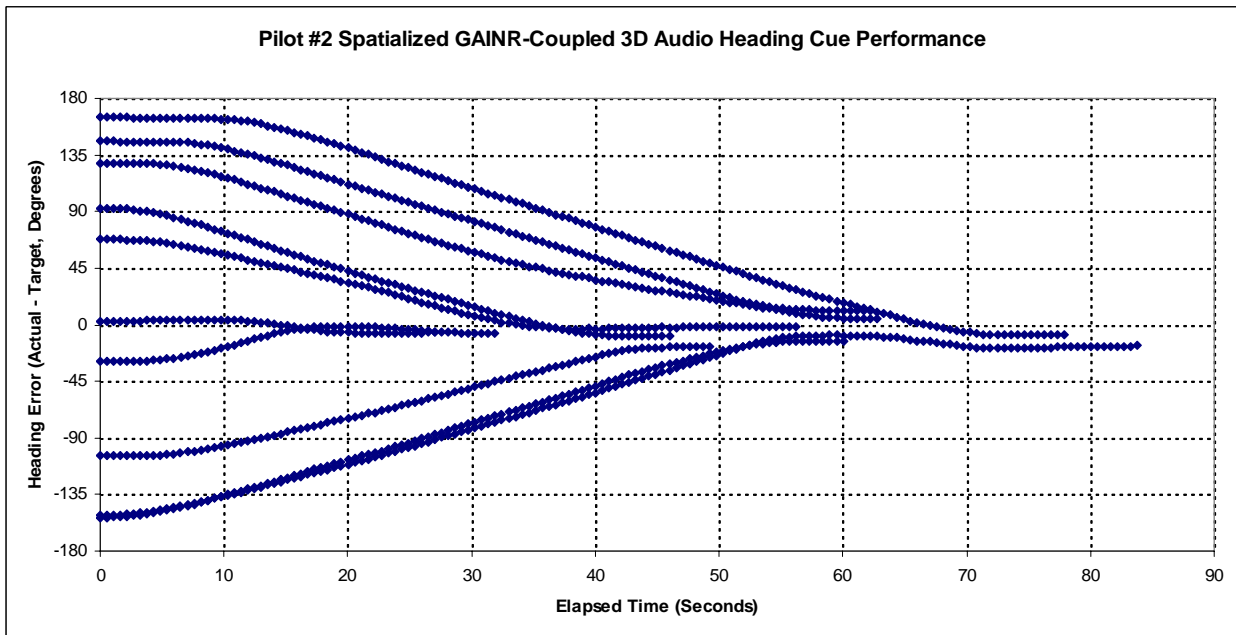

Figure C-37. Pilot #2 GAINR-Coupled 3D Audio Heading Cue Performance

DATA BASIS: Flight Test	Test A/C: C-12C SN#73-1215	Test Dates: 14 Oct – 2 Nov 04
Weights: 10.000 lb – 12.500 lb	Airspeeds: 150-190 KIAS	Altitude: 10-14k ft

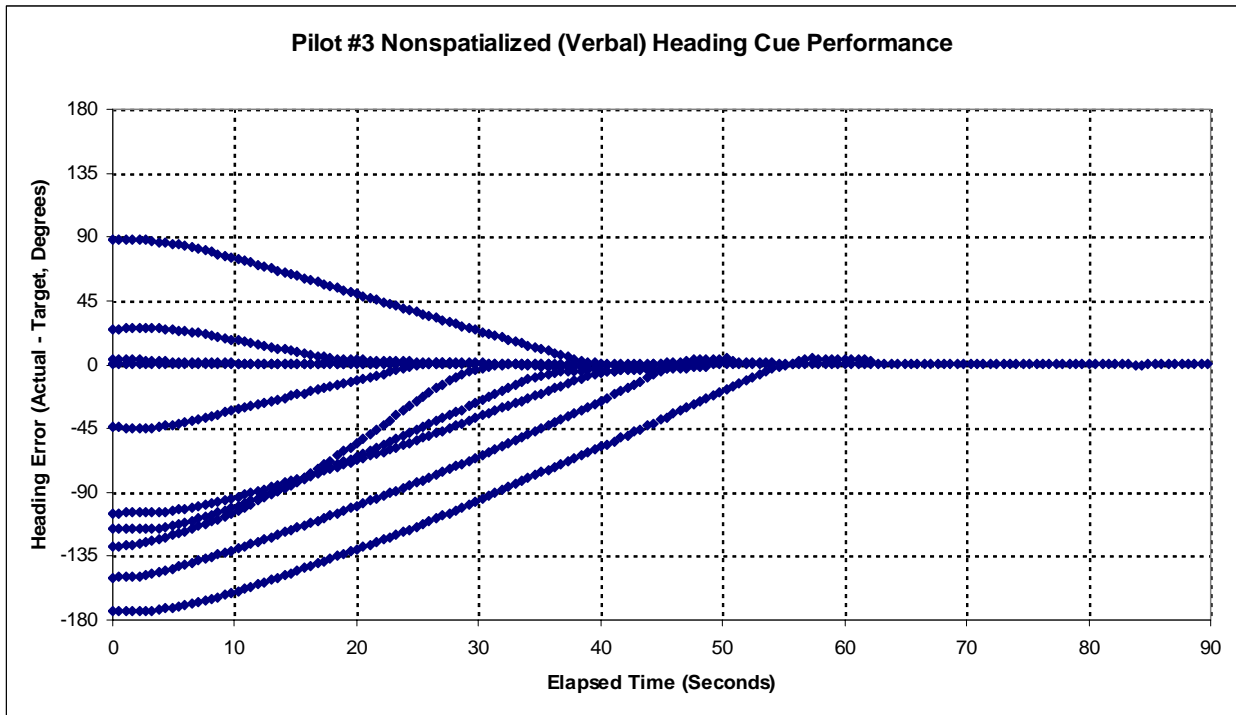

Figure C-38. Pilot #3 Baseline Verbal Heading Cue Performance

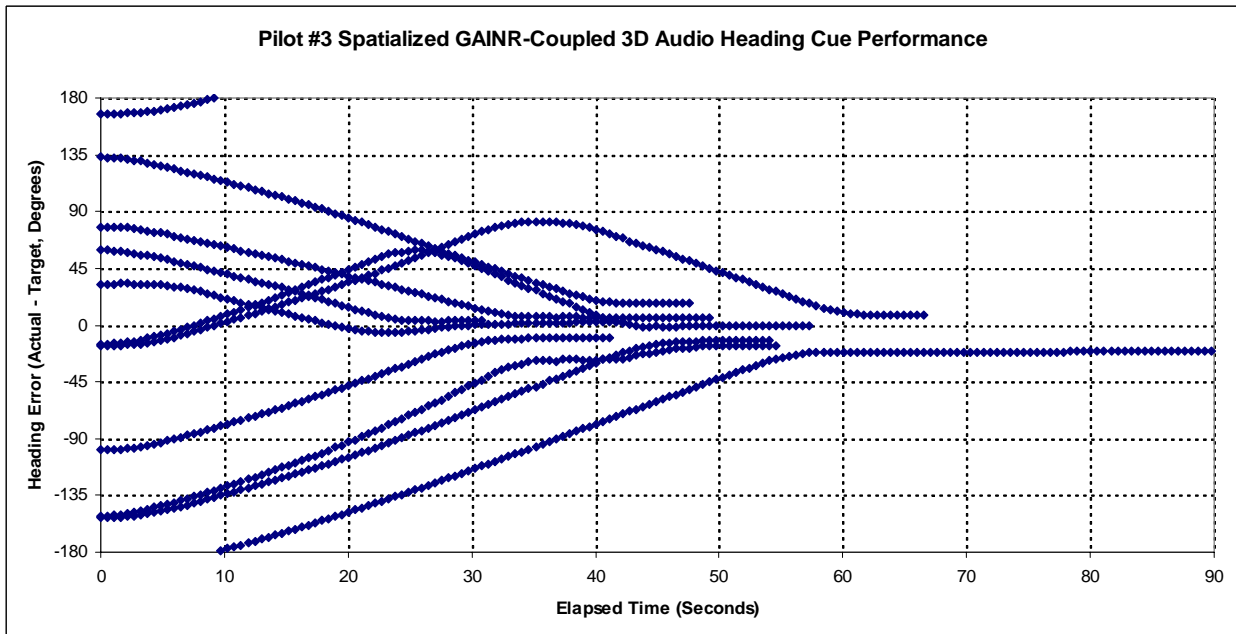

Figure C-39. Pilot #3 GAINR-Coupled 3D Audio Heading Cue Performance

DATA BASIS: Flight Test Test A/C: C-12C SN#73-1215 Test Dates: 14 Oct – 2 Nov 04
Weights: 10,000 lb – 12,500 lb Airspeeds: 150-190 KIAS Altitude: 10-14k ft

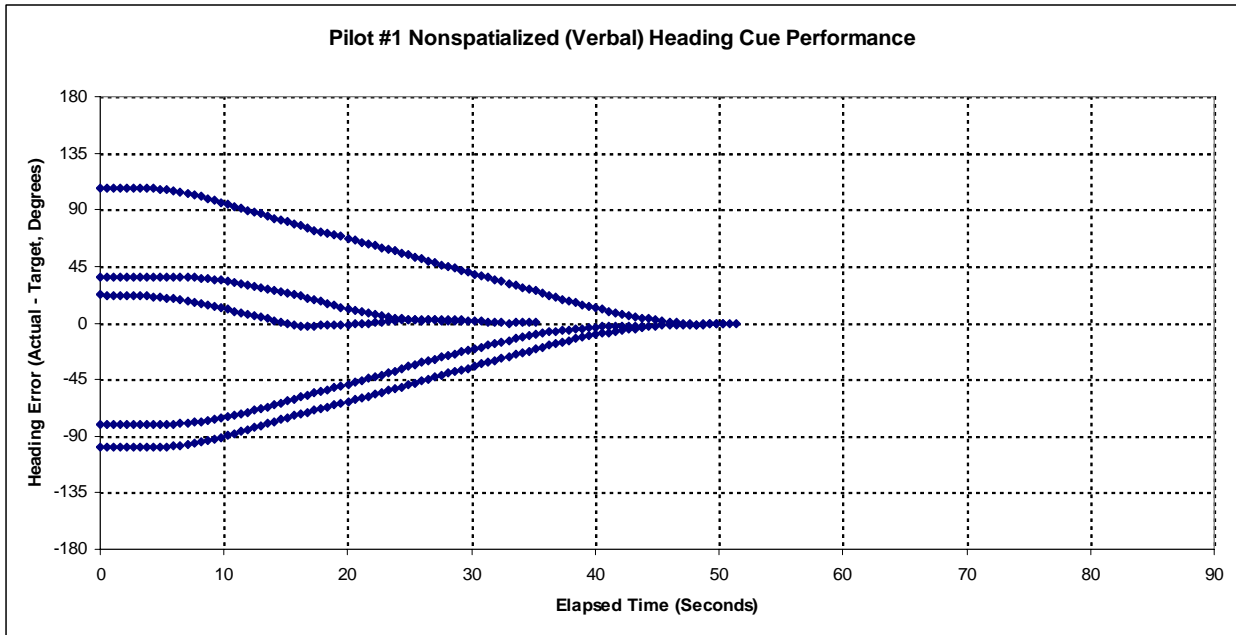

Figure C-40. Pilot #1 Baseline Verbal Heading Cue Performance

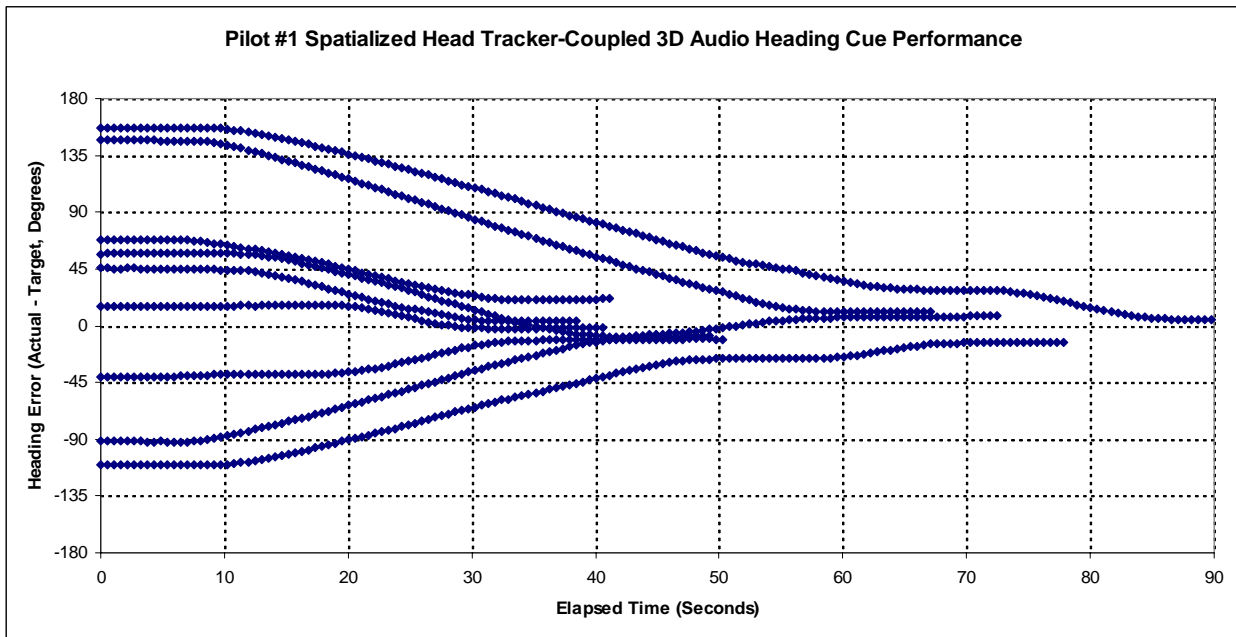

Figure C-41. Pilot #1 Head Tracker-Coupled 3D Audio Heading Cue Performance

DATA BASIS: Flight Test Test A/C: C-12C SN#73-1215 Test Dates: 14 Oct – 2 Nov 04
Weights: 10.000 lb – 12.500 lb Airspeeds: 150-190 KIAS Altitude: 10-14k ft

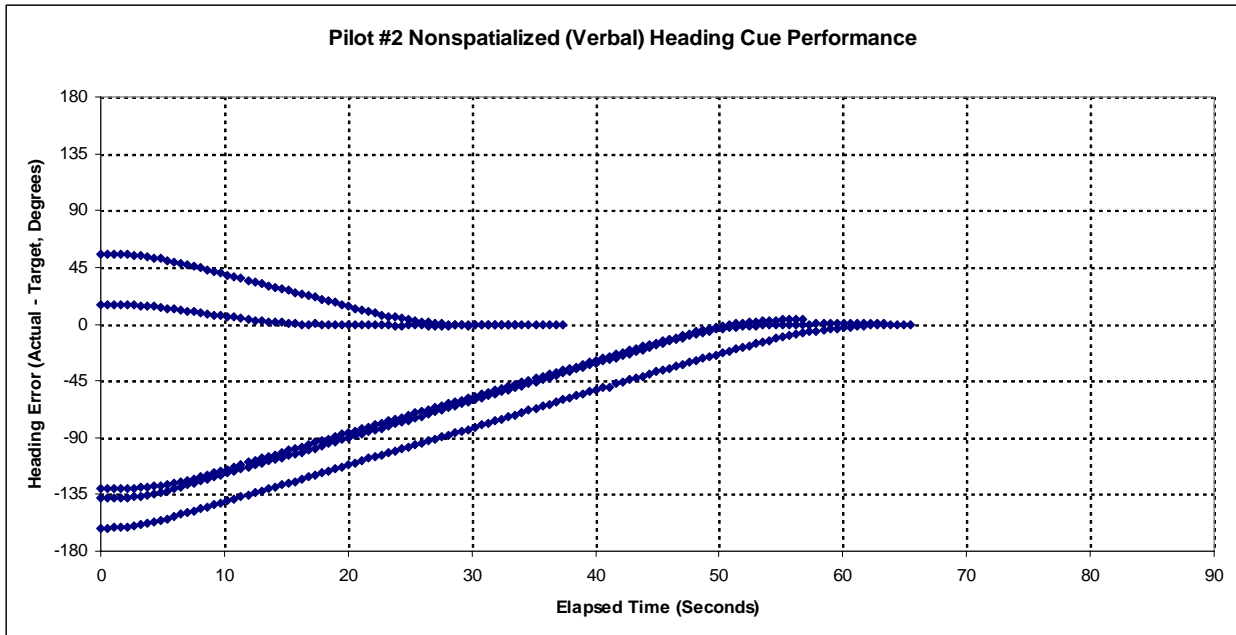

Figure C-42. Pilot #2 Baseline Verbal Heading Cue Performance

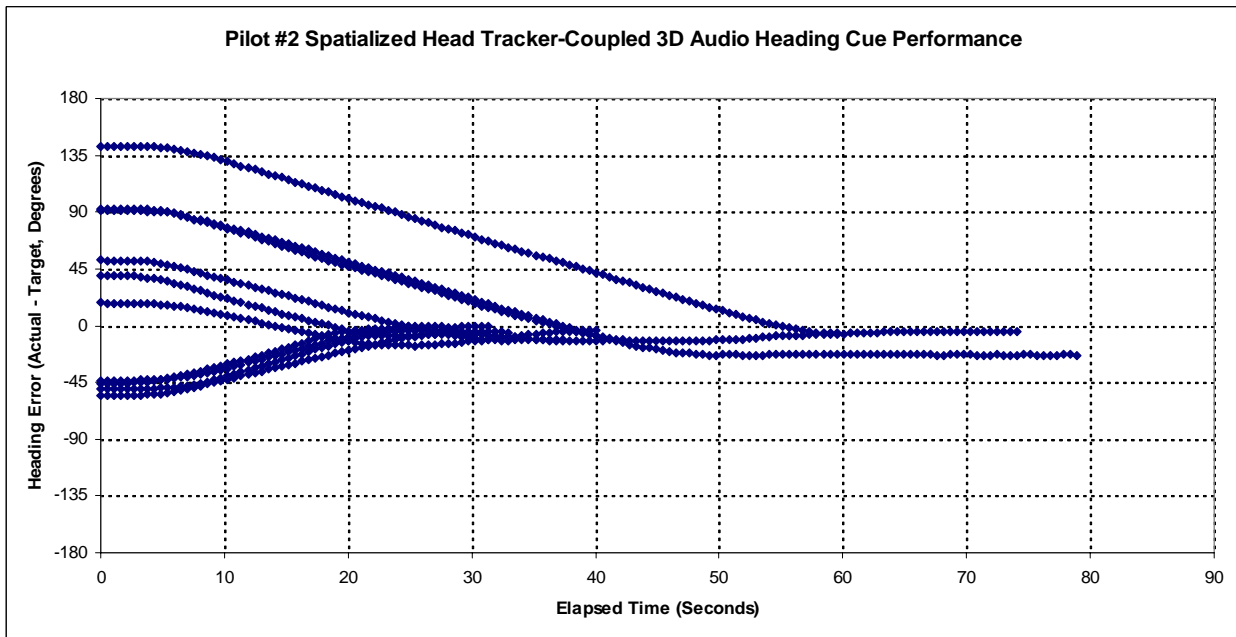

Figure C-43. Pilot #2 Head Tracker-Coupled 3D Audio Heading Cue Performance

DATA BASIS: Flight Test	Test A/C: C-12C SN#73-1215	Test Dates: 14 Oct – 2 Nov 04
Weights: 10,000 lb – 12,500 lb	Airspeeds: 150-190 KIAS	Altitude: 10-14k ft

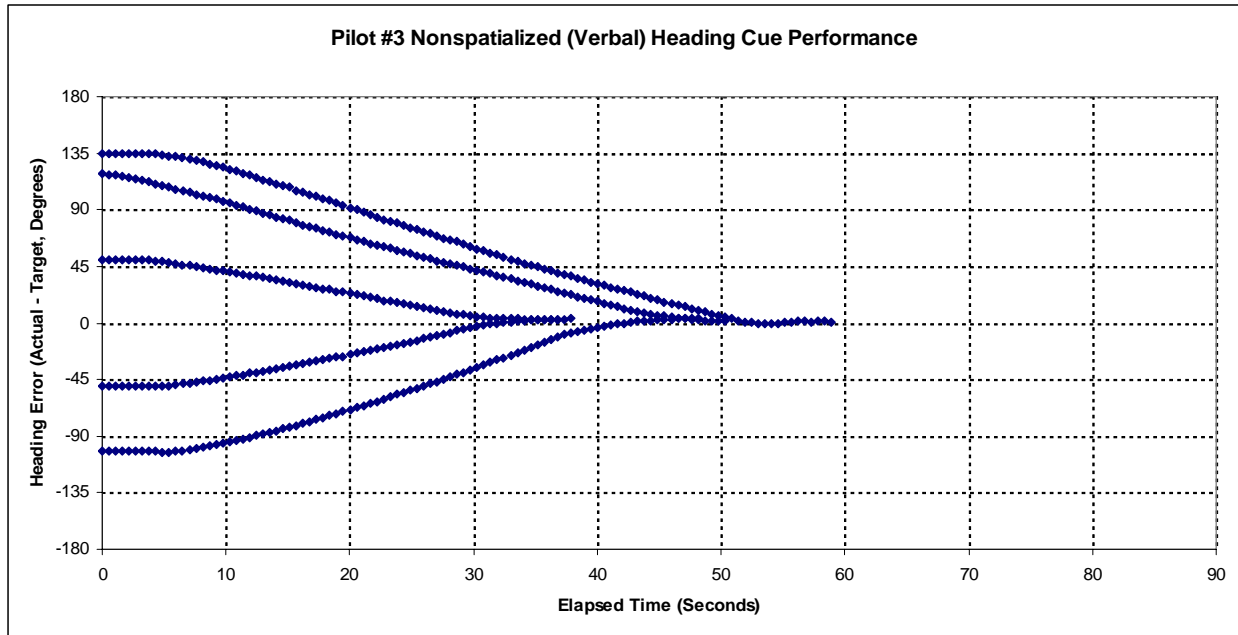

Figure C-44. Pilot #3 Baseline Verbal Heading Cue Performance

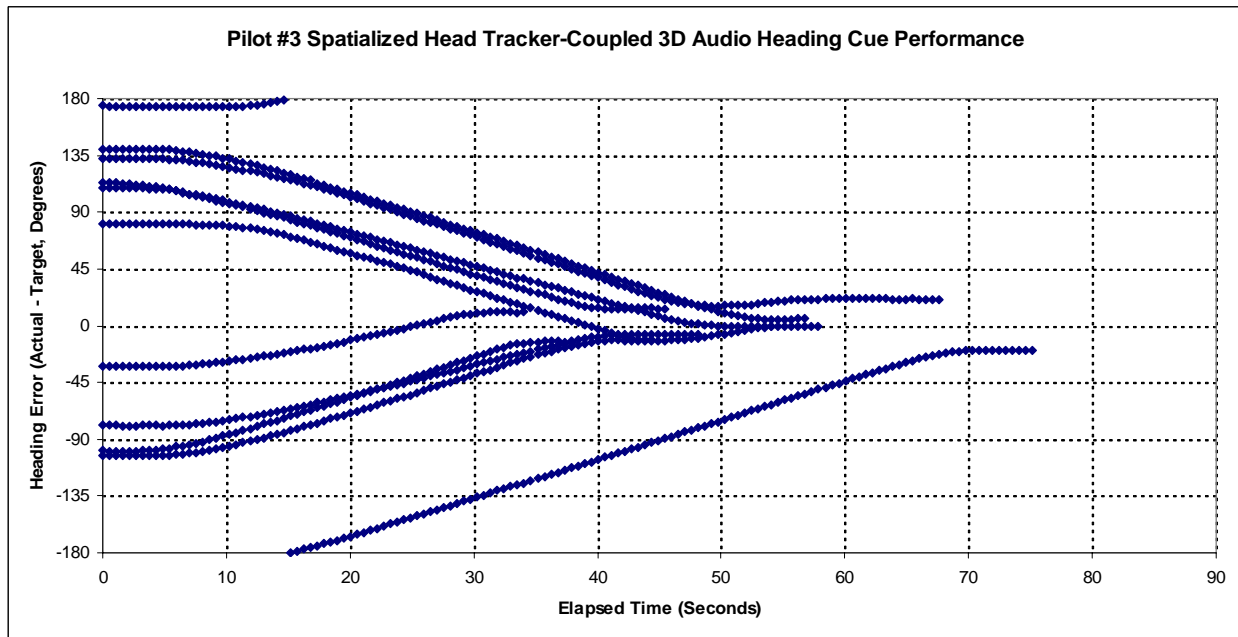

Figure C-45. Pilot #3 Head Tracker-Coupled 3D Audio Heading Cue Performance

DATA BASIS: Flight Test	Test A/C: C-12C SN#73-1215	Test Dates: 14 Oct – 2 Nov 04
Weights: 10.000 lb – 12.500 lb	Airspeeds: 150-190 KIAS	Altitude: 10-14k ft

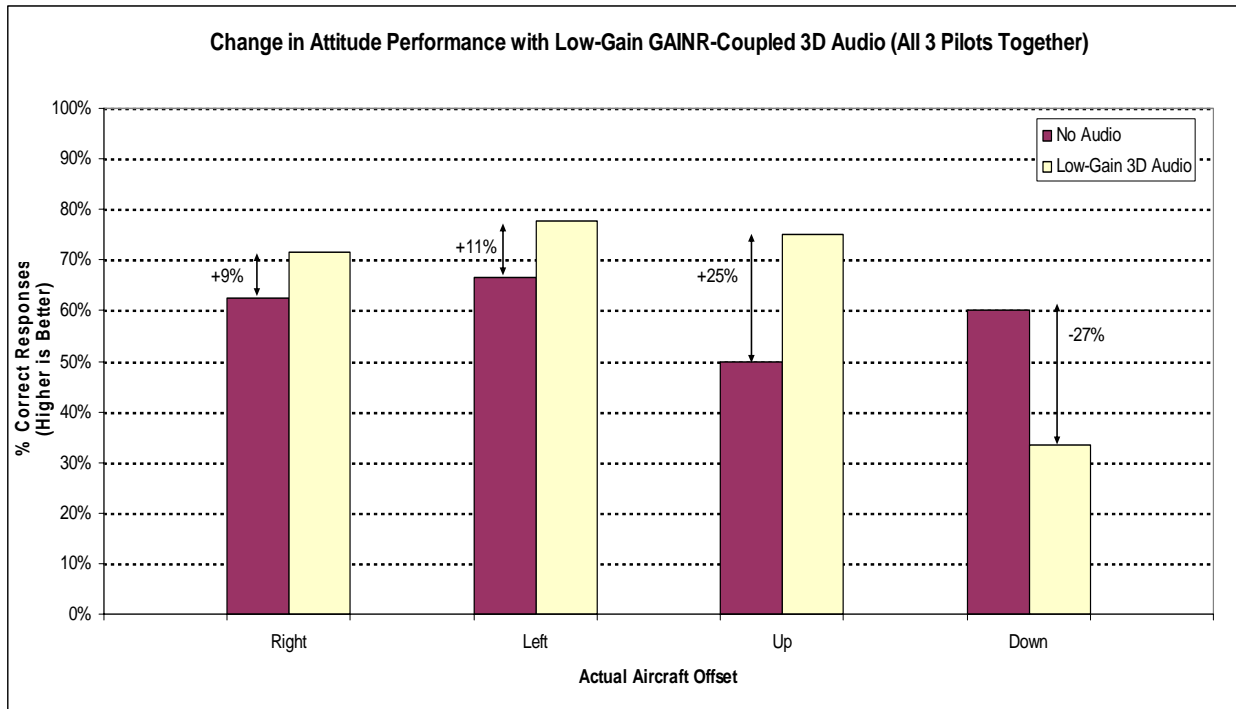

Figure C-46. Correct Responses to Change in Attitude with Low-Gain 3D Audio

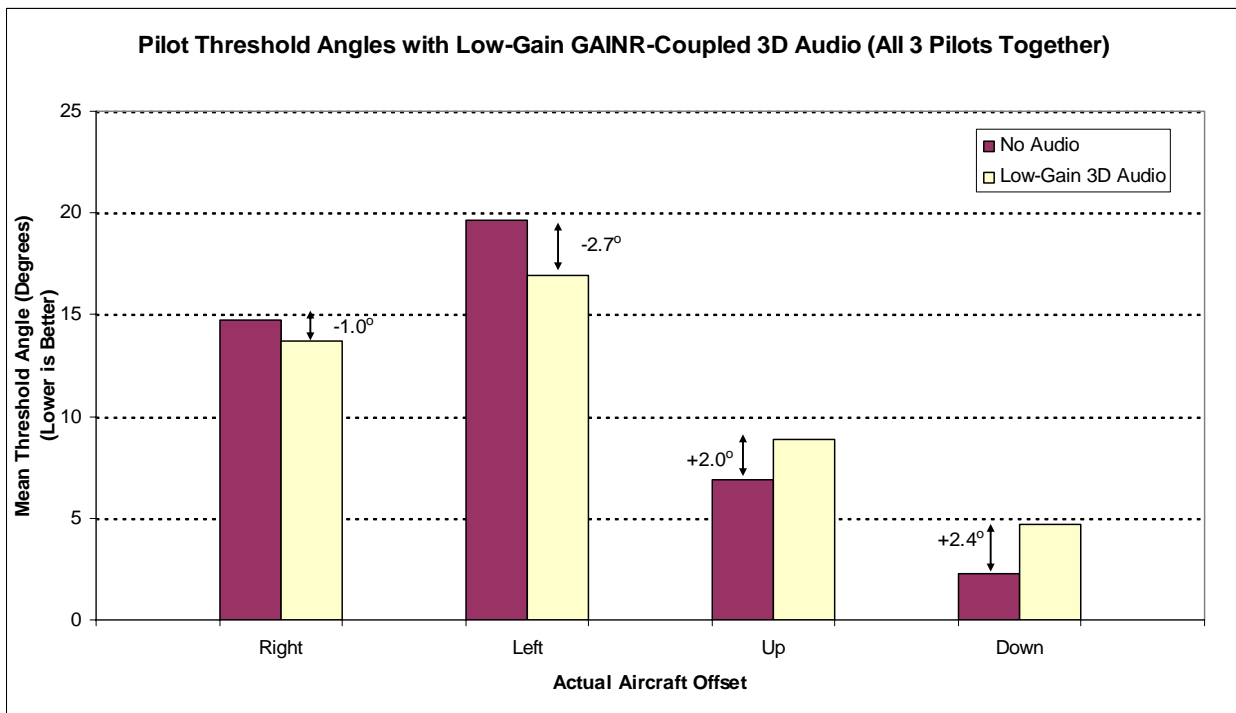

Figure C-47. Mean Threshold Angles with Low-Gain 3D Audio

DATA BASIS: Flight Test	Test A/C: C-12C SN#73-1215	Test Dates: 14 Oct – 2 Nov 04
Weights: 10.000 lb – 12.500 lb	Airspeeds: 150-190 KIAS	Altitude: 10-14k ft

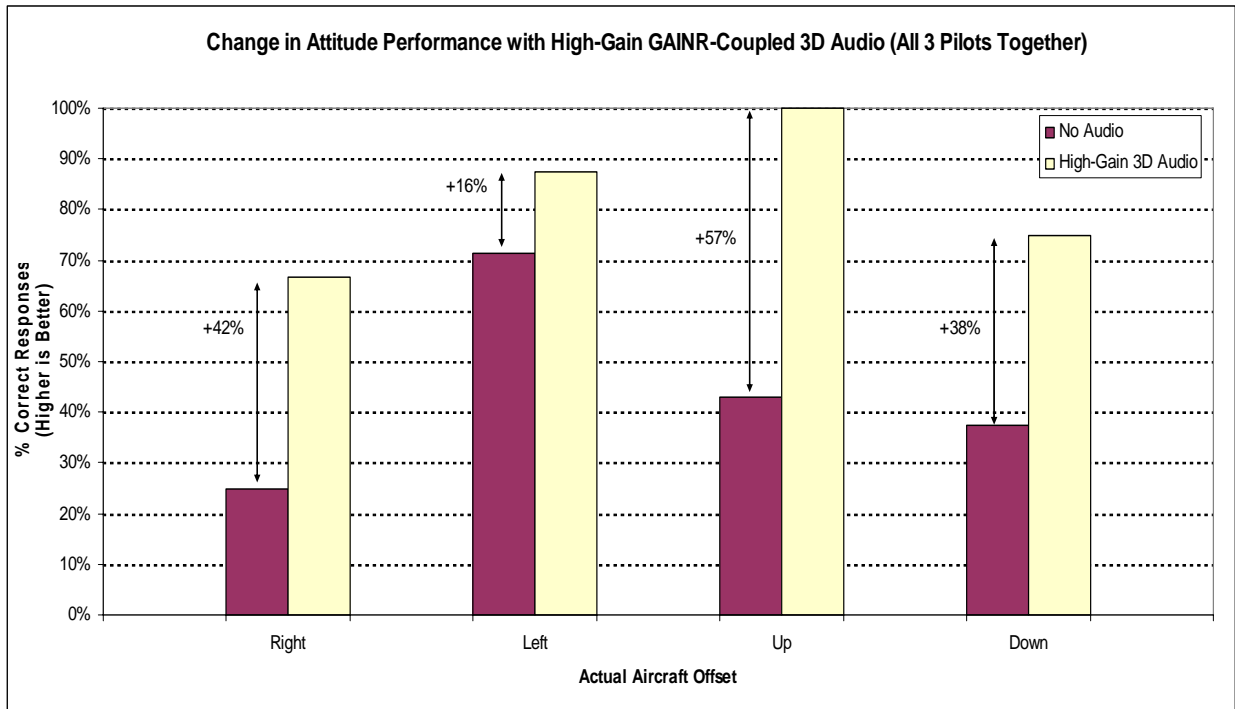

Figure C-48. Correct Responses to Change in Attitude with High-Gain 3D Audio

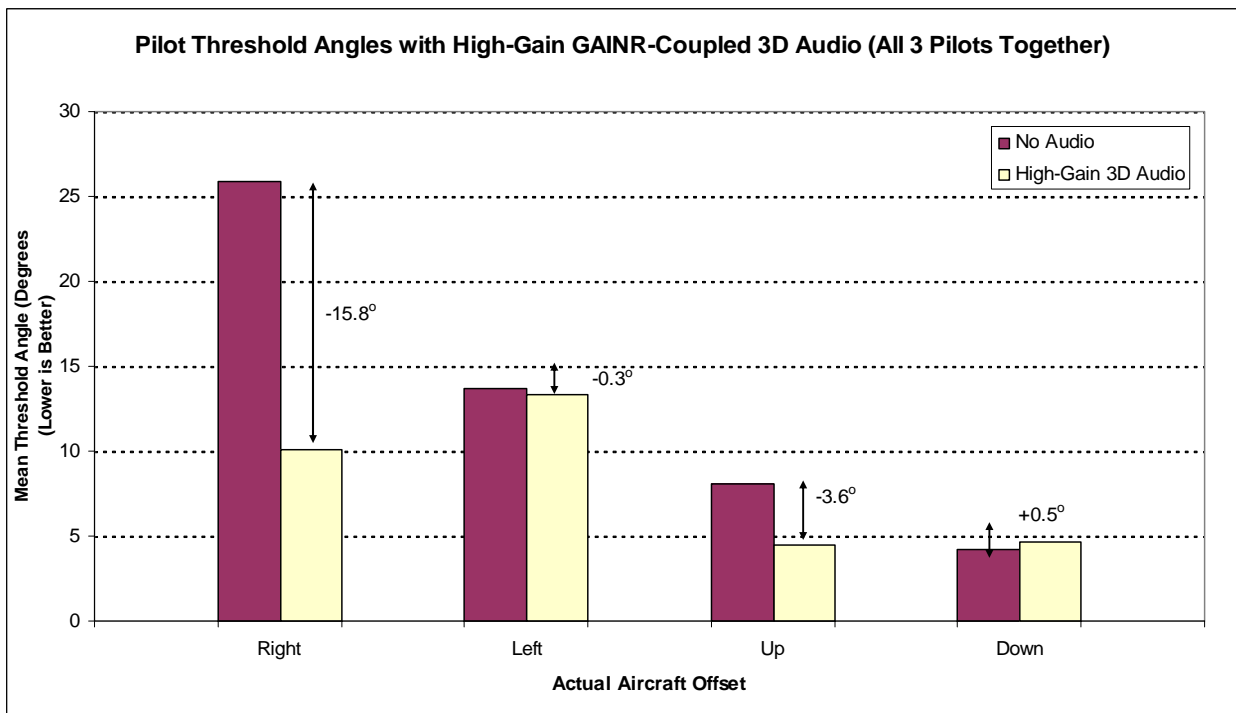

Figure C-49. Mean Threshold Angles with High-Gain 3D Audio

DATA BASIS: Flight Test	Test A/C: C-12C SN#73-1215	Test Dates: 14 Oct – 2 Nov 04
Weights: 10,000 lb – 12,500 lb	Airspeeds: 150-190 KIAS	Altitude: 10-14k ft

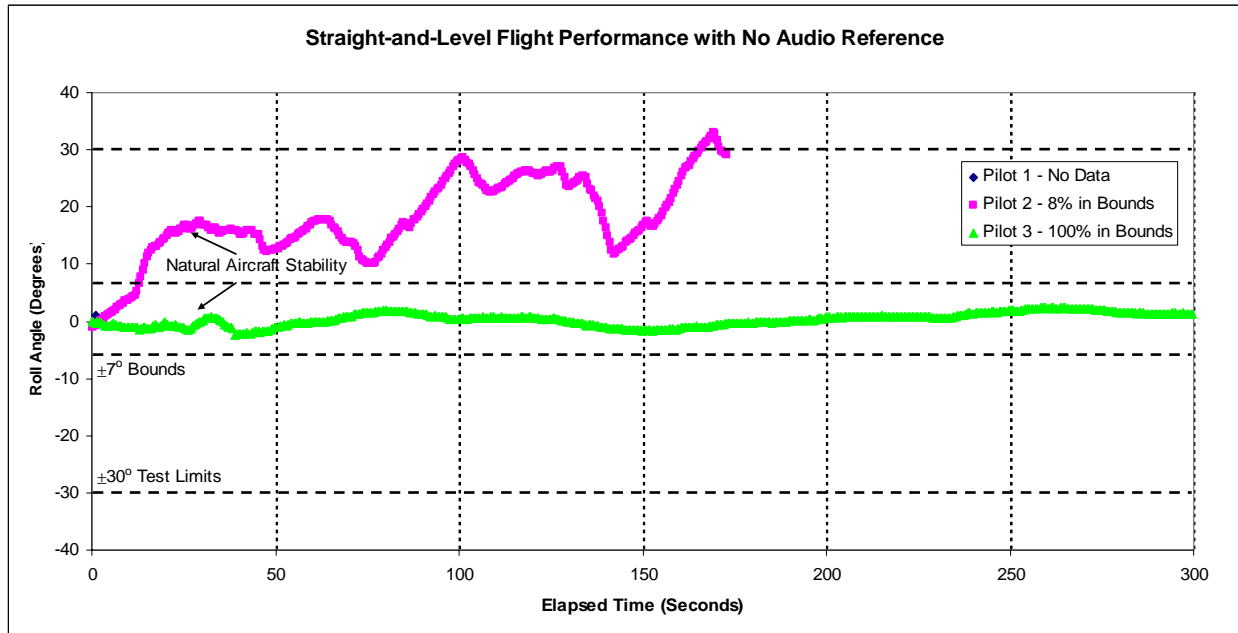

Figure C-50. Straight/Level Flight Roll Angle with No Audio Reference

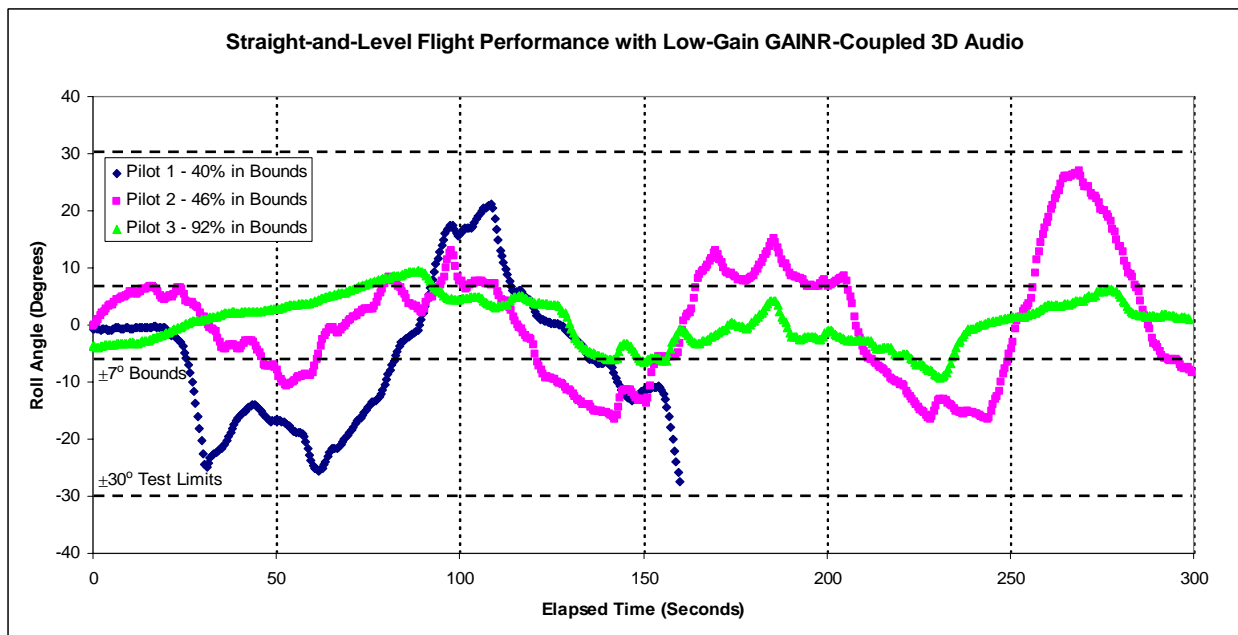

Figure C-51. Straight/Level Flight Roll Angle with Low-Gain GAINR-Coupled 3D Audio

DATA BASIS: Flight Test	Test A/C: C-12C SN#73-1215	Test Dates: 14 Oct – 2 Nov 04
Weights: 10,000 lb – 12,500 lb	Airspeeds: 150-190 KIAS	Altitude: 10-14k ft

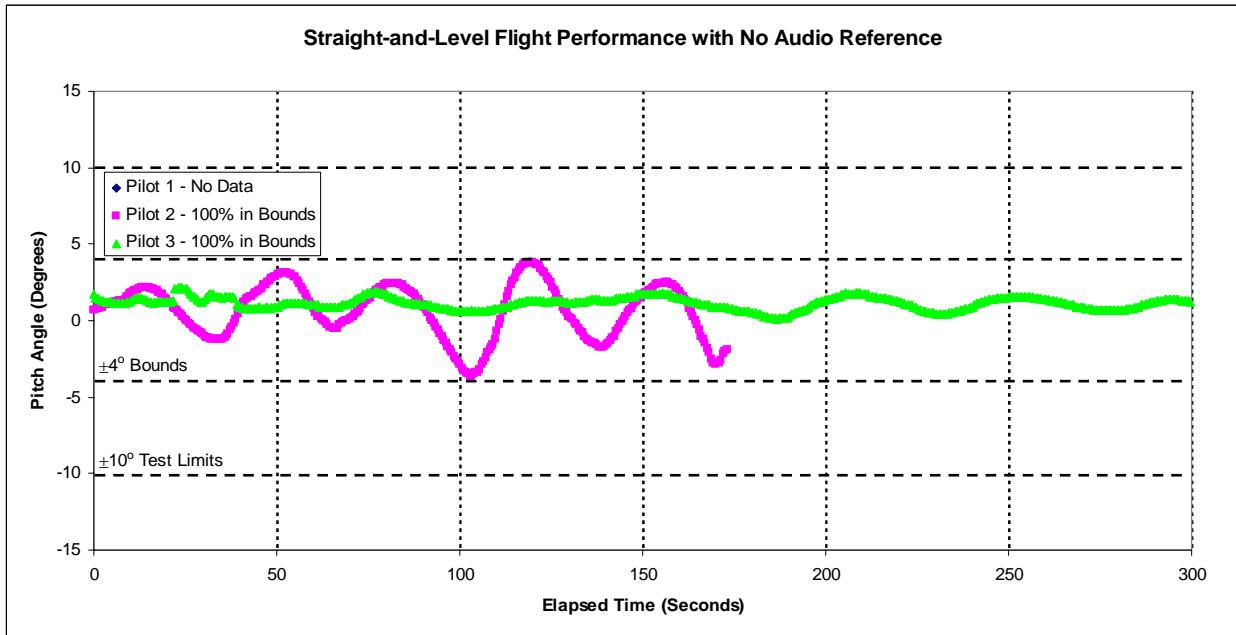

Figure C-52. Straight/Level Flight Pitch Angle with No Audio Reference

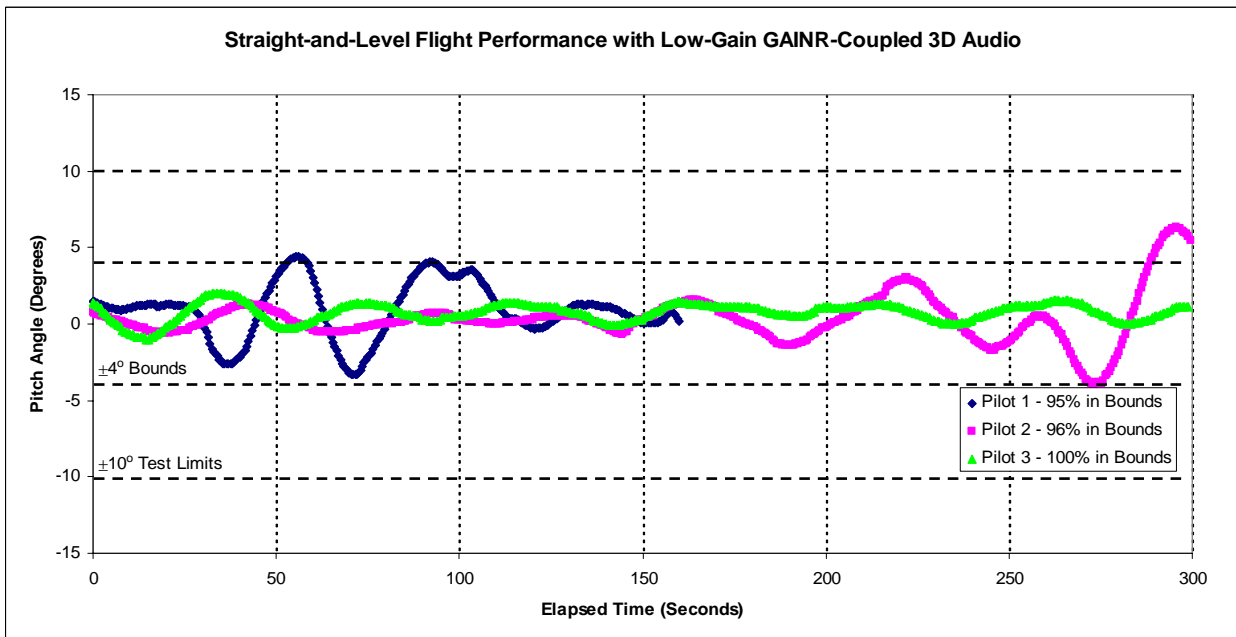

Figure C-53. Straight/Level Flight Pitch Angle with Low-Gain GAINR-Coupled 3D Audio

DATA BASIS: Flight Test	Test A/C: C-12C SN#73-1215	Test Dates: 14 Oct – 2 Nov 04
Weights: 10,000 lb – 12,500 lb	Airspeeds: 150-190 KIAS	Altitude: 10-14k ft

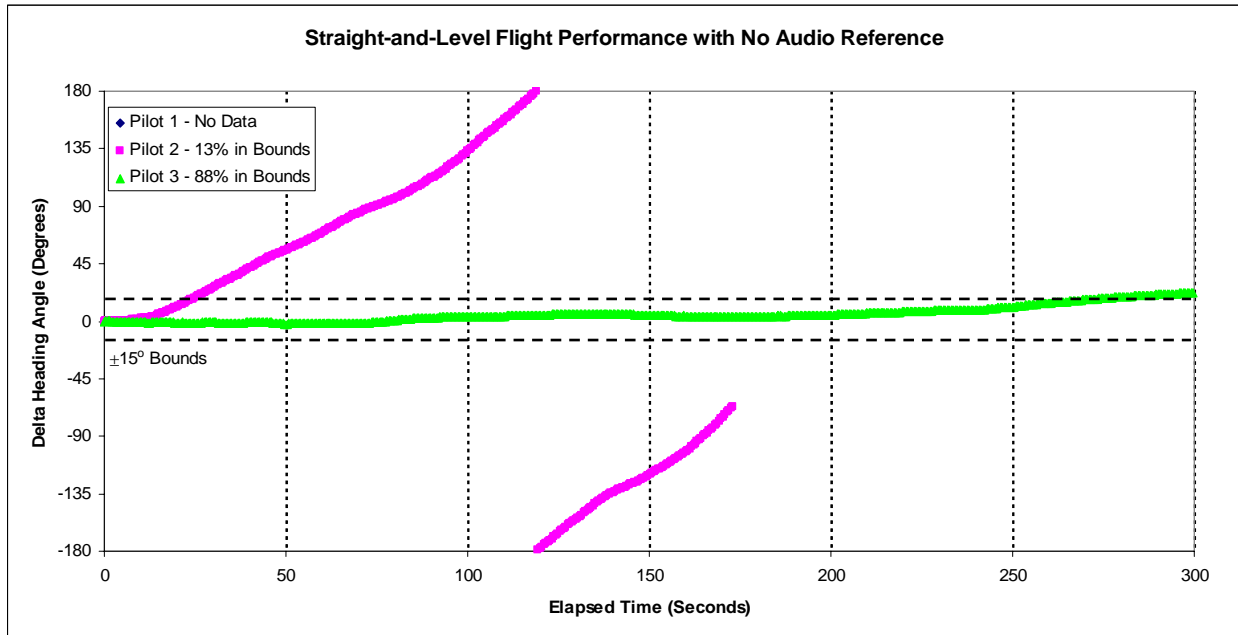

Figure C-54. Straight/Level Flight Heading with No Audio Reference

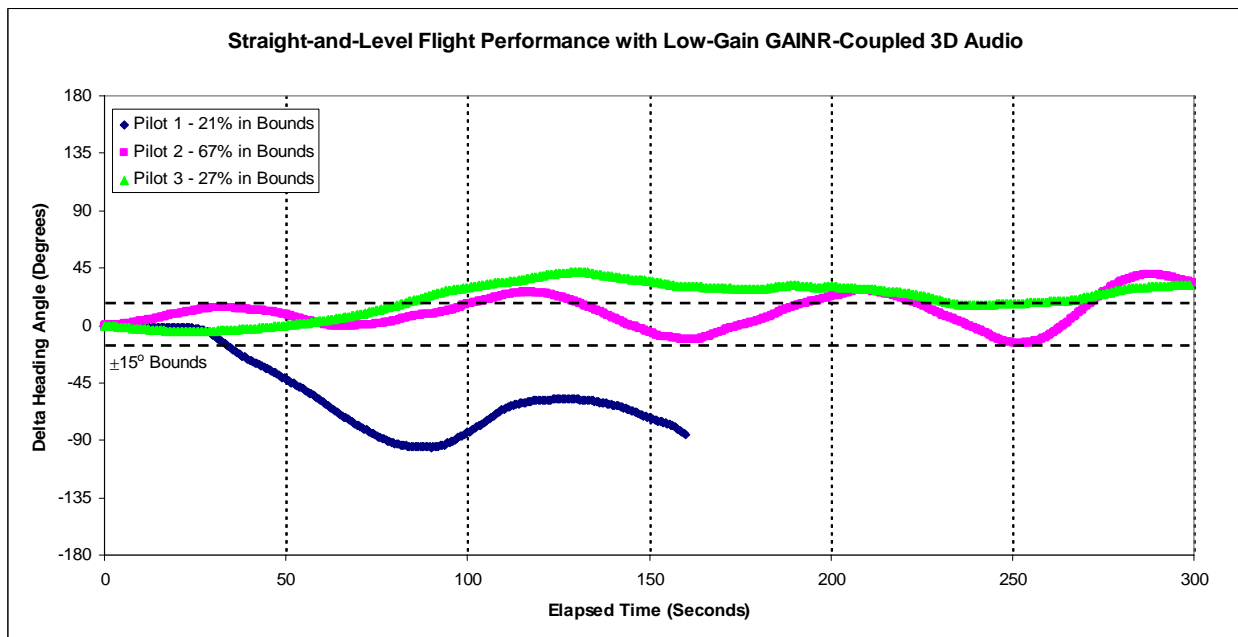

Figure C-55. Straight/Level Flight Heading with Low-Gain GAINR-Coupled 3D Audio

DATA BASIS: Flight Test	Test A/C: C-12C SN#73-1215	Test Dates: 14 Oct – 2 Nov 04
Weights: 10,000 lb – 12,500 lb	Airspeeds: 150-190 KIAS	Altitude: 10-14k ft

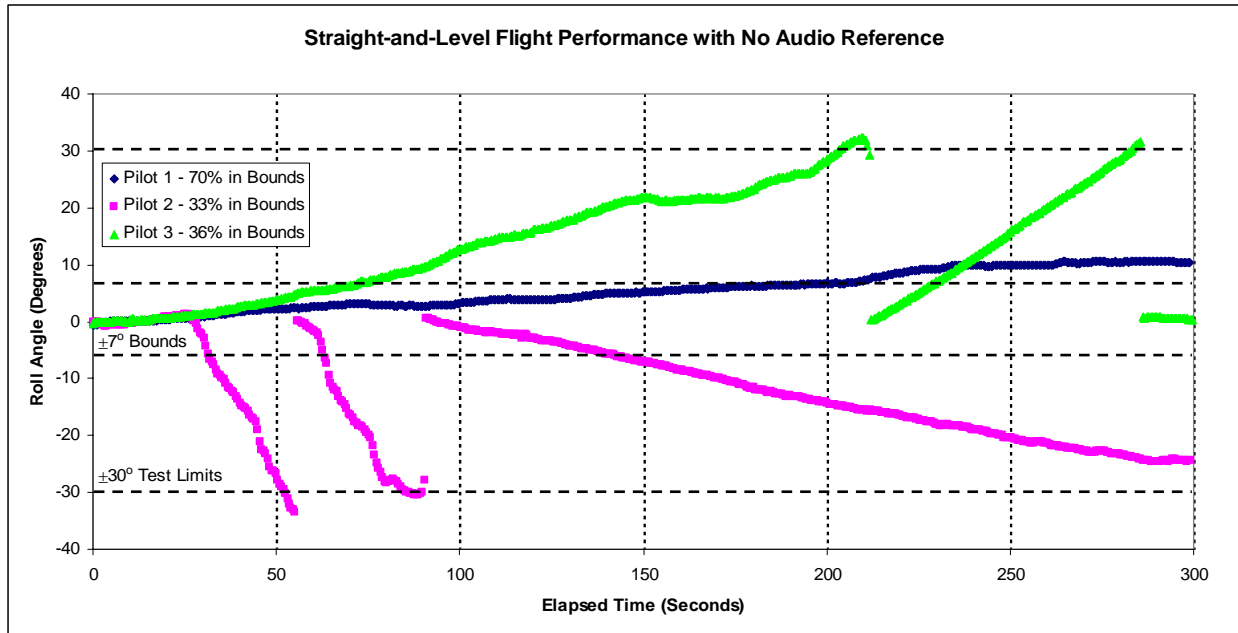

Figure C-56. Straight/Level Flight Roll Angle with No Audio Reference

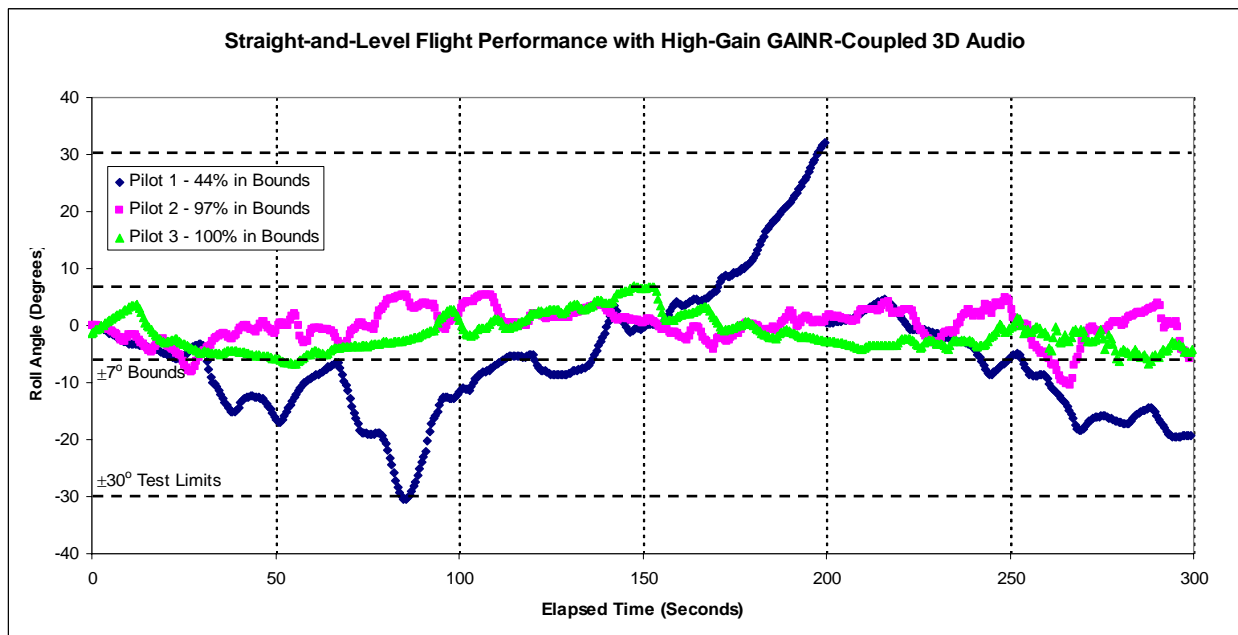

Figure C-57. Straight/Level Flight Roll Angle with High-Gain GAINR-Coupled 3D Audio

DATA BASIS: Flight Test	Test A/C: C-12C SN#73-1215	Test Dates: 14 Oct – 2 Nov 04
Weights: 10,000 lb – 12,500 lb	Airspeeds: 150-190 KIAS	Altitude: 10-14k ft

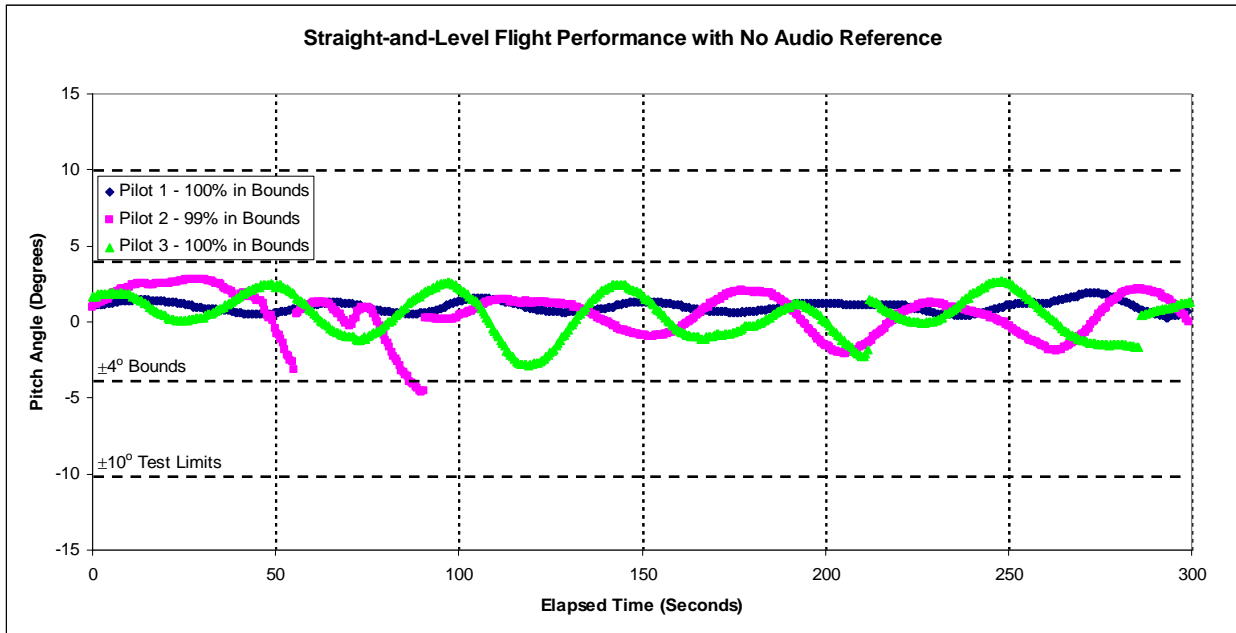

Figure C-58. Straight/Level Flight Pitch Angle with No Audio Reference

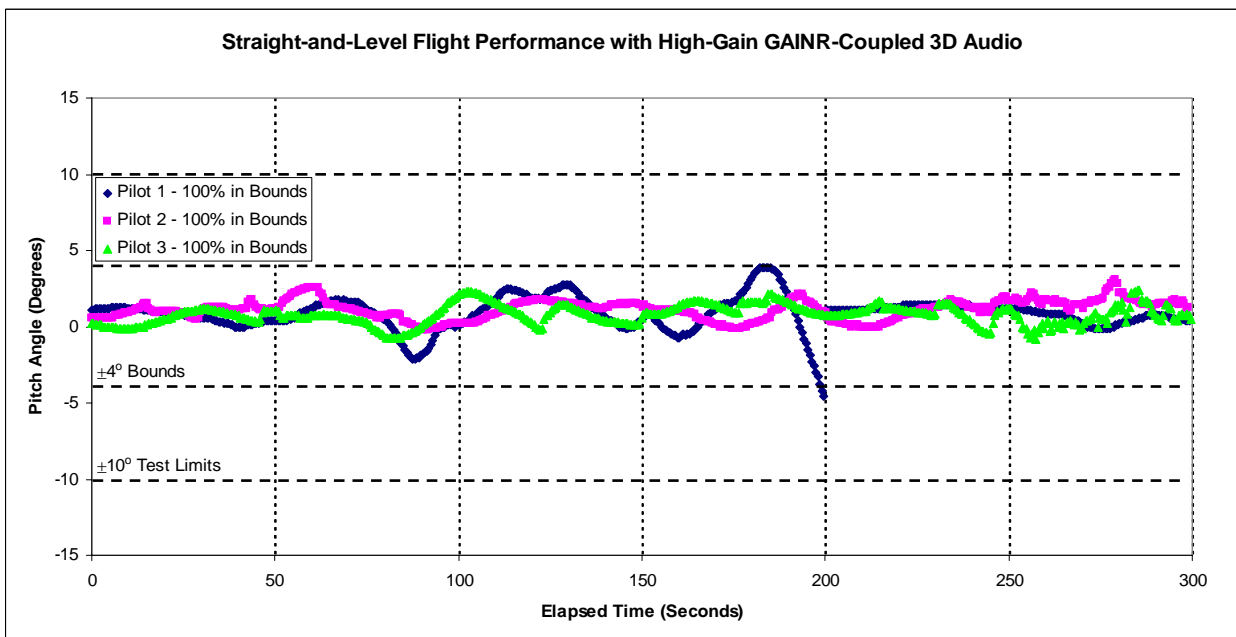

Figure C-59. Straight/Level Flight Pitch Angle with High-Gain GAINR-Coupled 3D Audio

DATA BASIS: Flight Test	Test A/C: C-12C SN#73-1215	Test Dates: 14 Oct – 2 Nov 04
Weights: 10,000 lb – 12,500 lb	Airspeeds: 150-190 KIAS	Altitude: 10-14k ft

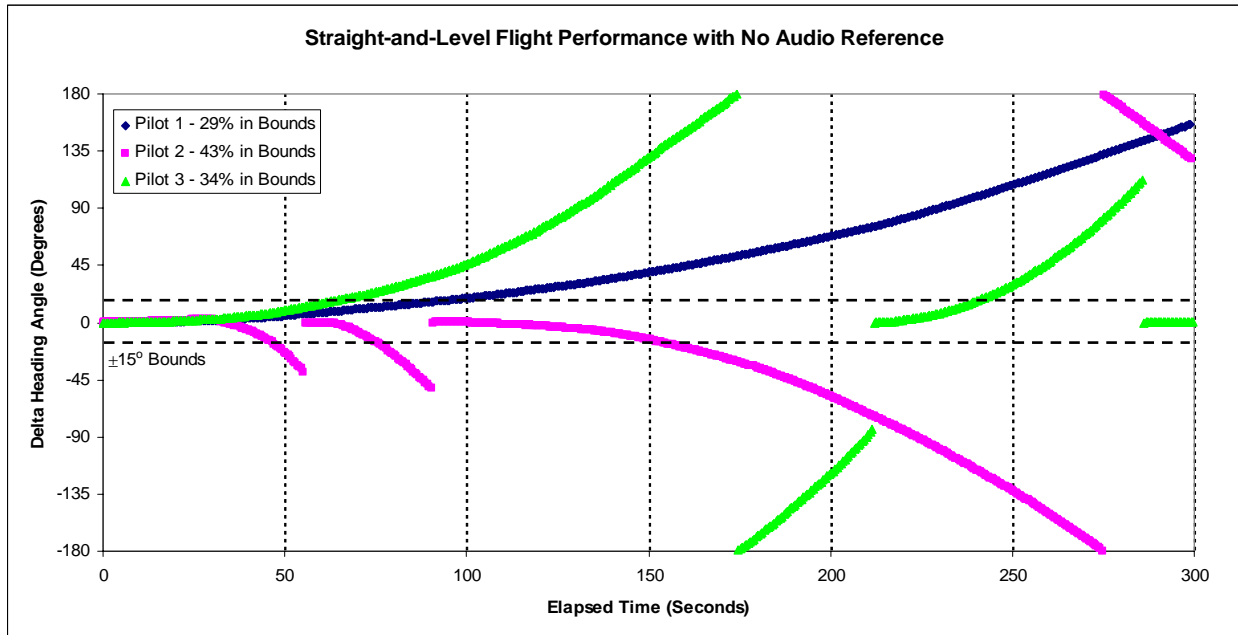

Figure C-60. Straight/Level Flight Heading with No Audio Reference

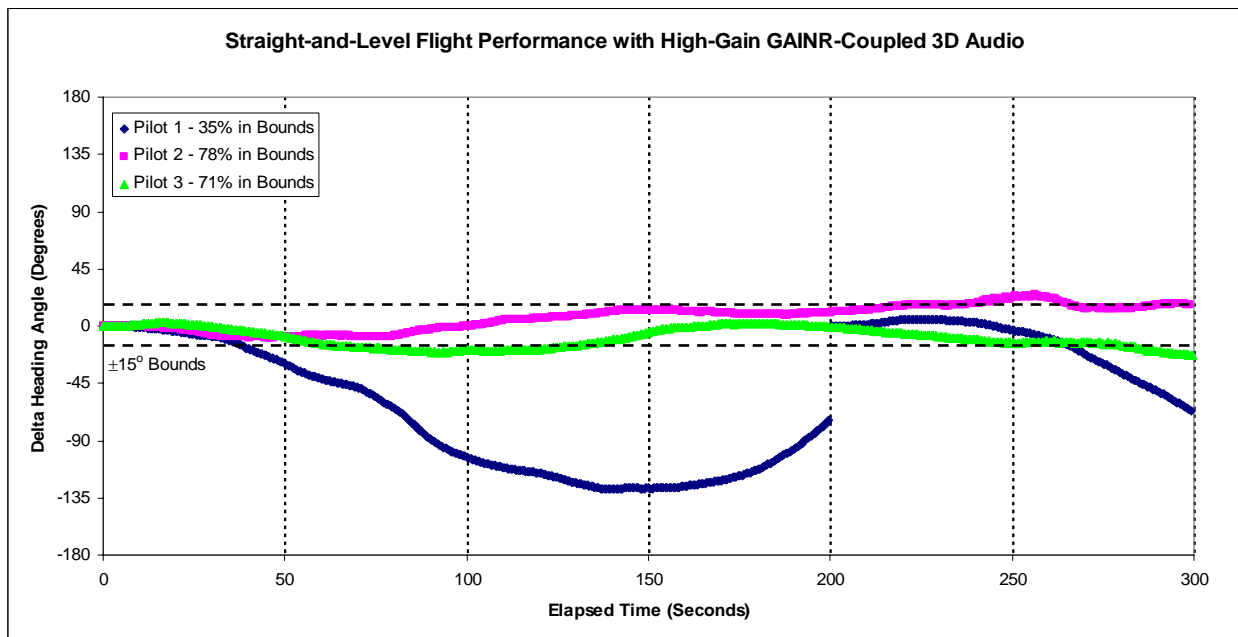

Figure C-61. Straight/Level Flight Heading with High-Gain GAINR-Coupled 3D Audio

APPENDIX D – LIST OF ACRONYMS

AFIT/ENG	Air Force Institute of Technology Department of Electrical & Computer Engineering
AFRL/HECB	Air Force Research Laboratory Human Effectiveness Directorate Battlespace Acoustics Branch
DAS	Data Acquisition System
DC/AC	Direct/Alternating Current
GAINR	GPS Aided Inertial Reference
IMU	Inertial Measurement Unit
MEMS	Microelectromechanical System
MFM	Modification Flight Manual
MOS	Modification Operational Supplement
RAF	Royal Air Force
SHSS	Steady Heading Side Slip
TIM	Technical Information Memorandum
TPS/04A	Test Pilot School Education Division, Alpha Class
TPS/EDT	Test Pilot School Education Division, Test Management Branch
TPS/TS	Test Pilot School Special Instrumentation
TSPI	Time, Space, Position Information
TW	Test Wing
3D	Three-Dimensional



APPENDIX E – DISTRIBUTION LIST

On-Site Paper-Copy Distribution

<u>Office</u>	<u>Number of Copies</u>
412 TW/ENFH Attn: Ms. Deborah A. Moisio 30 N Wolfe Ave., Bldg. 1609 Edwards AFB CA 93524-6843	1
412 TW/ENTL AFFTC Technical Library 307 E Popson Ave, Bldg 1400, Rm 110 Edwards AFB CA 93524-6630	3
412 TW/ENVB Attn: Mr. Michael E. Bonner 30 N Wolfe Ave., Bldg. 1609 Edwards AFB CA 93524-6843	1
AFFTC/HO 305 E Popson Ave, Bldg 1405 Edwards AFB CA 93524-6595	1
USAF TPS/EDC Attn: Ms. Dottie Meyer 220 S Wolfe Ave, Bldg 1220 Edwards AFB CA 93524-6485	2
USAF TPS/EDT Attn: Mr. Gary L. Aldrich 220 S Wolfe Ave, Bldg 1220 Edwards AFB CA 93524-6485	2
419 FLTS Attn: Capt Jacque Joffrion Edwards AFB, CA 93524	4
418 FLTS Attn: Capt Frank Delsing Edwards AFB, CA 93524	1
416 FLTS Attn: Capt Mike Presnar Edwards AFB, CA 93524	1

Off-Site Paper-Copy Distribution

<u>Office</u>	<u>Number of Copies</u>
AFIT/ENG Attn: Dr. John F. Raquet 2950 Hobson Way, Bldg. 641 Wright-Patterson AFB OH 45433-7765	1
AFRL/HECB Attn: Douglas S. Brungart 2610 Seventh Street Wright-Patterson AFB OH 45433-7901	2
Defense Technical Information Center Attn: Willis Smith (DTIC-OCA) 8725 John J. Kingman Road Suite 0944 Ft. Belvoir VA 22060-6218	1
NASA Langley Research Center Flight Operations and Support Division Attn: Michael S. Wusk Hampton VA 23681-0001	1
NASIC/TAA 4180 Watson Way Wright-Patterson AFB OH 45433-5648	1

Adobe® PDF File Distribution

<u>Email Address</u>
jacque.joffrion@edwards.af.mil
michael.presnar@edwards.af.mil
john.shinoskie@edwards.af.mil
frank.delsing@edwards.af.mil
christopher.hamilton@edwards.af.mil
karl.major@edwards.af.mil
christopher.mccann@edwards.af.mil
john.raquet@afit.edu
douglas.brungart@wpafb.af.mil
ron.dallman@wpafb.af.mil
m.s.wusk@larc.nasa.gov
michael.bonner@edwards.af.mil
deborah.moisio@edwards.af.mil
john.minor@edwards.af.mil
mark.novelli@edwards.af.mil
larry.jones@edwards.af.mil
luan.tran@edwards.af.mil
Defense Technical Information Center (provide CD with Paper Copy)