

# Subarray Beam-Space Adaptive Beamforming for a Dynamic Long Towed Array

*Yung P. Lee and Herbert Freese*

SAIC

phone: 703-676-6512

email: yung.p.lee@saic.com

email: herbert.a.freese@saic.com

*William W. Lee*

University of Maryland

email: willee@wam.umd.edu

**Abstract** In the fast time-varying shallow water environment, the phone-space adaptive processing using sample-matrix-inversion (SMI) approach outperforms the iterative least-mean-squared (LMS) approach due to its rapid convergence. The SMI approach uses singular-value-decomposition (SVD) to decompose a sample-matrix into a set of spatial eigenvectors and their associated eigenvalues. Adaptive beamforming is applied by matching the steering vectors with the spatial eigenvectors weighted by their eigenvalues. When a long towed-array undergoes significant maneuvering, the array shape and/or the target-to-array relative geometry changes rapidly within a processing interval. A signal in the phone-space sample-matrix is split into more than one eigenvector resulting in signal mismatch in the subsequent beamforming. Its power is split into many eigenvalues resulting in signal loss in the processing.

In subarray beam-space adaptive beamforming (SABS ABF), a beam-space sample-matrix is formed at each search cell by focusing subarrays to a cell using the dynamically updated array shape at each time step. The SMI adaptive beamforming then is done by decomposing the beam-space sample-matrix and matching the beam-eigenvectors with a unity steering vector. The beam-space sample-matrix has a lower rank than the phone-space sample-matrix so that a stable estimation can be reached with fewer time samples. The dynamic array shape compensation in SABS ABF makes a signal in the beam-space sample-matrix less likely to be split by the SVD. The subsequent processing, after the SVD, experiences less signal mismatch and signal loss. A dynamic cable model is used to simulate a long towed-array going through turns in a measured shallow water current field. Simulations show that significant signal loss in phone-space SMI processing is recovered in SABS ABF processing.

## Report Documentation Page

*Form Approved*  
*OMB No. 0704-0188*

Public reporting burden for the collection of information is estimated to average 1 hour per response, including the time for reviewing instructions, searching existing data sources, gathering and maintaining the data needed, and completing and reviewing the collection of information. Send comments regarding this burden estimate or any other aspect of this collection of information, including suggestions for reducing this burden, to Washington Headquarters Services, Directorate for Information Operations and Reports, 1215 Jefferson Davis Highway, Suite 1204, Arlington VA 22202-4302. Respondents should be aware that notwithstanding any other provision of law, no person shall be subject to a penalty for failing to comply with a collection of information if it does not display a currently valid OMB control number.

1. REPORT DATE <b>20 DEC 2004</b>	2. REPORT TYPE <b>N/A</b>	3. DATES COVERED <b>-</b>	
4. TITLE AND SUBTITLE <b>Subarray Beam-Space Adaptive Beamforming for A Dynamic Long Towed-Array</b>		5a. CONTRACT NUMBER	
		5b. GRANT NUMBER	
		5c. PROGRAM ELEMENT NUMBER	
6. AUTHOR(S)		5d. PROJECT NUMBER	
		5e. TASK NUMBER	
		5f. WORK UNIT NUMBER	
7. PERFORMING ORGANIZATION NAME(S) AND ADDRESS(ES) <b>Science Applications International; University of Maryland</b>		8. PERFORMING ORGANIZATION REPORT NUMBER	
9. SPONSORING/MONITORING AGENCY NAME(S) AND ADDRESS(ES)		10. SPONSOR/MONITOR'S ACRONYM(S)	
		11. SPONSOR/MONITOR'S REPORT NUMBER(S)	
12. DISTRIBUTION/AVAILABILITY STATEMENT <b>Approved for public release, distribution unlimited</b>			
13. SUPPLEMENTARY NOTES <b>See also, ADM001741 Proceedings of the Twelfth Annual Adaptive Sensor Array Processing Workshop, 16-18 March 2004 (ASAP-12, Volume 1), The original document contains color images.</b>			
14. ABSTRACT			
15. SUBJECT TERMS			
16. SECURITY CLASSIFICATION OF:			17. LIMITATION OF ABSTRACT
a. REPORT <b>unclassified</b>	b. ABSTRACT <b>unclassified</b>	c. THIS PAGE <b>unclassified</b>	<b>UU</b>
			18. NUMBER OF PAGES <b>27</b>
			19a. NAME OF RESPONSIBLE PERSON

# Subarray Beam-Space Adaptive Beamforming for A Dynamic Long Towed-Array

Yung P. Lee, Herbert Freese  
Science Applications International Corporation

William W. Lee  
University of Maryland

## Abstract:

In the fast time-varying shallow water environment, the phone-space adaptive processing using sample-matrix-inversion (SMI) approach outperforms iterative least-mean-squared (LMS) approach due to its rapid convergence. The SMI approach uses singular-value-decomposition (SVD) to decompose a block sample-matrix into a set of spatial singular vectors and their associated singular values. Adaptive beamforming is applied by matching the steering vectors with the spatial singular vectors weighted by their singular values. When a long towed-array undergoes significant maneuvering, its shape relative to a target changes rapidly within a processing interval. The target signal in the phone-space sample-matrix is split into more than one singular vector resulting signal mismatch in the subsequent beamforming. Its power is split into many singular values resulting signal loss in the processing.

In subarray beam-space adaptive beamforming (SABS\_ABF), a beam-space sample-matrix is formed at each search cell by focusing subarrays to a cell using the dynamically updated array shape at each time step. The SMI adaptive beamforming then is done by decomposing the beam-space sample-matrix and matching the beam-eigenvectors with a unity steering vector. The beam-space sample-matrix has a lower rank than the phone-space sample-matrix so that a stable estimation can be reached with fewer time samples. The dynamic array shape compensation in SABS\_ABF makes a signal in the beam-space sample-matrix less likely to be split by the SVD. The subsequent processing, after the SVD, experiences less signal mismatch and signal loss. A hydrodynamic cable model is used to simulate a long towed-array going through turns in a measured shallow water current field. Simulations show that significant signal loss in the phone-space adaptive processing is recovered in the SABS\_ABF processing.

## 1. Introduction

There are three main issues for a long towed-array going through dynamic maneuvering, they are increasing of array self-noise, rapid changing in array shape (array element location AEL), and signal spreading in the phone-space sample-matrix. Premus et. al. [1] showed

the use of a beam-space adaptive beamforming for towed array self-noise cancellation. Ianniello et. al. [2] demonstrated array shape estimation through turns using a hydrodynamic model with data from the non-acoustic heading and depth sensors. This paper addresses the issue of signal spreading that the received signal on an array changes within the processing interval due to array motion.

Figure 1 shows the simulation scenario using in this

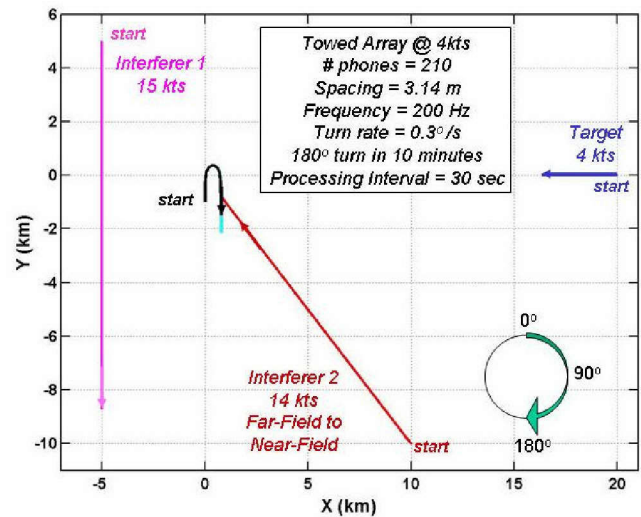

Figure 1: Simulation Geometry

study. A towed ship heads toward North at the beginning of the simulation, it makes an 180° turn in 10 minutes then heads toward South. A long array with 210 hydrophones and a spacing of 3.14 m is towed behind the ship with the first phone at 360 m from the ship. A hydrodynamic cable model is used to simulate a realistic motion of the array going through the turn in a measured shallow water current field. A target starts at a distance of 20 km and approaches the ship from East at a speed of 4 kts. In addition to the own-ship, two other interferers are included to simulate a stressful environment. One interferer starts from North-West, it crosses the back-beam of the target and heads to South. The other starts from South-East and moves into the near-field of the array. The simulation is done at 200 Hz with a sampling rate of every half second. All processing in this study uses a time interval of 30 seconds. True bearing is used for displaying the beamforming results.

Let  $x_n(t)$  be the received time series of the  $n^{\text{th}}$  hydrophone, the signal coherence (SC) relative to the first hydrophone is defined as

$$SC_n(t) = \frac{\left| \sum_{k=0}^{K-1} x_1^*(t+k\Delta t) \cdot x_n(t+k\Delta t) \right|^2}{\sum_{k=0}^{K-1} |x_1(t+k\Delta t)|^2 \cdot \sum_{k=0}^{K-1} |x_n(t+k\Delta t)|^2}$$

here  $K=60$  and  $\Delta t=0.5$  s. For target only, Figure 2 shows

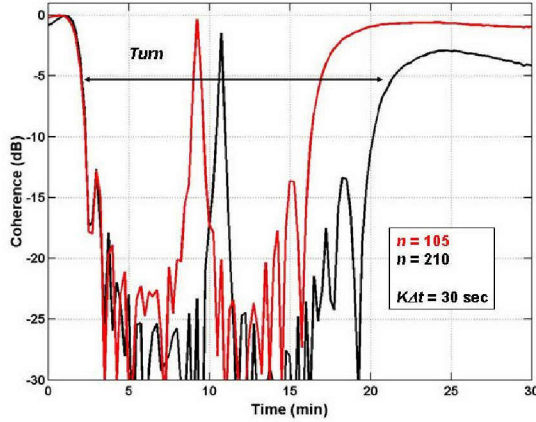

Figure 2: Time histories of signal coherence relative to phone one

the time history of signal coherence for hydrophone in the middle of the array ( $n=105$ ) and at the end of the array ( $n=210$ ), respectively. The signal coherence is close to perfect across array before the turn and is significantly degraded in the turn. The effect of the residual tail motion after the turn is seen in hydrophone 210.

Let  $X$  be a phone-space sample-matrix for a processing interval  $K\Delta t$  and

$$X = \begin{bmatrix} x_1(t) & x_1(t+\Delta t) & x_1(t+2\Delta t) & \dots & x_1(t+(K-1)\Delta t) \\ x_2(t) & x_2(t+\Delta t) & x_2(t+2\Delta t) & \dots & x_2(t+(K-1)\Delta t) \\ \vdots & \vdots & \vdots & \ddots & \vdots \\ x_N(t) & x_N(t+\Delta t) & x_N(t+2\Delta t) & \dots & x_N(t+(K-1)\Delta t) \end{bmatrix}$$

After singular-value-decomposition (SVD),  $X$  can be written as

$$X = V\Lambda U$$

where  $V$  and  $U$  are orthogonal matrices, and  $\Lambda$  is a diagonal matrix

$$\Lambda = \begin{bmatrix} \sqrt{\lambda_1} & 0 & \dots & 0 \\ 0 & \sqrt{\lambda_2} & \dots & 0 \\ \vdots & \vdots & \ddots & \vdots \\ 0 & 0 & \dots & \sqrt{\lambda_N} \end{bmatrix}$$

The columns  $v_i$  and  $u_i$  of  $V$  and  $U$  are called the left and right singular vectors, respectively, and the diagonal elements  $\lambda_i$  of  $\Lambda$  are called the singular values.

Physically, each  $v_i$  represents a spatial structure of a signal observed across the array of hydrophones, the associated  $u_i$  contains the information of temporal variation of this signal, and  $\lambda_i$  is the mean power of the observed signal. For target only, Figure 3 shows the singular-value time

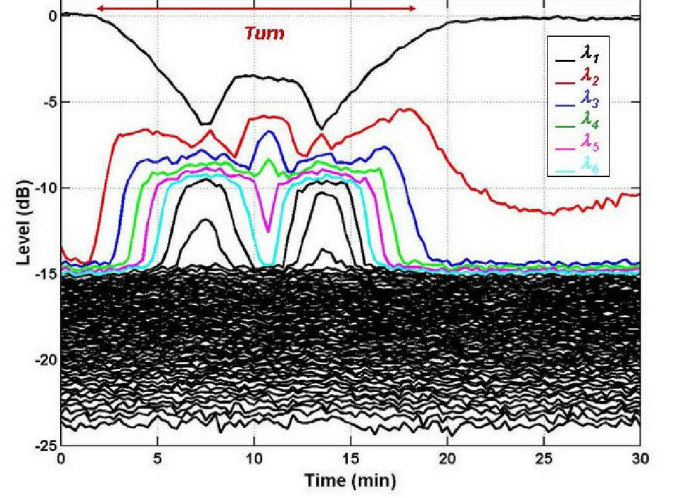

Figure 3: Singular-Value time histories of the phone-space sample-matrix for target only

histories. It shows that target energy is contained within one singular value before the turn and is spread into several singular values in the turn. Without an appropriate signal model to account for the spread, target estimation using the phone-space sample-matrix will be significantly degraded.

Subarray beam-space processing is a two-stage processing. In the first stage, a phone-space sample-matrix is transformed into a beam-space sample-matrix using the dynamically updated AEL. The transformation compensates the temporal variation of the received signal on the array due to rapid changes in array shape. The signal in the beam-space sample-matrix is more stationary and experiences less spread so that the subsequent processing can achieve the optimal result. This paper is organized as follows: Section 2 reviews the white-noise-constrained adaptive beamforming, Section 3 describes the subarray beam-space adaptive beamforming (SABS\_ABF), Section 4 shows the simulation results, and Section 5 summaries the study.

## 2. White-Noise-Constrained (WNC) Adaptive Beamforming

Adaptive processing uses the measured signal plus noise data vectors to minimize the sidelobe contributions from those components that do not match with the steering vector for a given search cell. Let  $R$  be the covariance matrix of the received signal and noise, and  $R = \langle XX^* \rangle$  where  $\langle \rangle$  denotes ensemble average over a

number of sequential data vectors  $X$  and “+” denotes Hermitian transpose. The minimum variance distortionless response (MVDR) method minimizes the variance at the output of a linear weighting of the hydrophone array subject to the distortionless constraint that signals in the steering direction have unity gain. The formulation minimizes the variance given by

$$S_{MVDR} = \mathbf{W}^+ \mathbf{R} \mathbf{W}$$

with respect to the weighting  $\mathbf{W}$ , subject to the unity gain constraint

$$\mathbf{W}^+ \mathbf{A} = 1$$

where  $\mathbf{A}$  is a steering vector. The MVDR weight vector  $\mathbf{W}_{MVDR}$  can be derived as

$$\mathbf{W}_{MVDR} = \frac{\mathbf{R}^{-1} \mathbf{A}}{\mathbf{A}^+ \mathbf{R}^{-1} \mathbf{A}}$$

where  $\mathbf{R}^{-1}$  is matrix inversion. The MVDR output is

$$S_{MVDR} = \frac{1}{\mathbf{A}^+ \mathbf{R}^{-1} \mathbf{A}}$$

Applying the eigen-value decomposition, the covariance matrix  $\mathbf{R}$  can be decomposed into a set of eigenvectors  $\mathbf{V}_i$  associated with a set of eigenvalues  $\lambda_i$ , so that

$$\mathbf{R} = \sum_{i=1}^N \lambda_i \mathbf{V}_i \mathbf{V}_i^+$$

and the inverse of the covariance matrix is given by

$$\mathbf{R}^{-1} = \sum_{i=1}^N \frac{1}{\lambda_i} \mathbf{V}_i \mathbf{V}_i^+$$

The MVDR weight vector becomes

$$\mathbf{W}_{MVDR} = \frac{\sum_{i=1}^N \frac{1}{\lambda_i} (\mathbf{V}_i^+ \mathbf{A}) \mathbf{V}_i}{\sum_{i=1}^N \frac{1}{\lambda_i} |\mathbf{V}_i^+ \mathbf{A}|^2}$$

The MVDR output becomes

$$S_{MVDR} = \left( \sum_{i=1}^N \frac{1}{\lambda_i} |\mathbf{V}_i^+ \mathbf{A}|^2 \right)^{-1}$$

An alternative way to obtain  $\mathbf{V}_i$  and  $\lambda_i$  described in Section 1 is applying singular-value decomposition to a sample-matrix.

Without mismatch between data and model and when the signal is loud enough, the steering vector  $\mathbf{A}$  is perfectly matched with signal eigenvector in the steering direction. The rest of eigenvectors are orthogonal to the steering vector and have no effect on the output. But, when mismatch is present, the steering vector is no longer orthogonal to the rest of eigenvectors. The noise vectors associated with the least significant eigenvalues then dominate the inverse processing and degrade the signal estimation.

All forms of mismatch are either deterministic or random. Deterministic mismatch degrades the signal estimation and causes bias in estimation, but it can be minimized if a prior knowledge is included in modeling the signal. Random mismatch degrades the signal estimation but will not bias the estimation. Random mismatch cannot be minimized so that robust algorithms were developed to tolerate it to a certain level. The white-noise-gain constrained (WNC) method referred to by Cox [3], dynamically adjusts the sensor noise level by adding white noise power to the diagonal elements of the covariance matrix subject to an inequality constraint on the sensor noise gain. Adding noise expands the noise space and effectively eliminates small eigenvalues that would otherwise dominate the sum in the MVDR output calculation due to mismatch.

The MVDR white noise processing gain, defined as the amplitude squared of the weight vector  $|\mathbf{W}_{MVDR}|^2$ , is directly proportional to the signal-to-noise ratio (SNR). The MVDR signal degradation due to mismatch is inversely proportional to the SNR. At low SNR, the white noise processing gain approaches unity (the conventional linear processing noise gain) and the mismatch effect is negligible. At high SNR, the white noise processing gain is high and the MVDR output is very sensitive to mismatch. For each steering direction, the WNC method dynamically adjusts the sensor noise level by adding white noise to the diagonal elements of the covariance matrix. Adding white noise lowers the “apparent” SNR so that the processing becomes less sensitive to mismatch. Adding white noise, in the amount  $\epsilon$ , to the diagonal elements of the covariance matrix is the same as adding  $\epsilon$  to each eigenvalues without modifying the eigenvectors. The WNC weight vector  $\mathbf{W}_{WNC}$  that result is

$$\mathbf{W}_{WNC} = \frac{\sum_{i=1}^N \frac{1}{\lambda_i + \epsilon} (\mathbf{V}_i^+ \mathbf{A}) \mathbf{V}_i}{\sum_{i=1}^N \frac{1}{\lambda_i + \epsilon} |\mathbf{V}_i^+ \mathbf{A}|^2}$$

and the WNC output is

$$S_{WNC} = \frac{\sum_{i=1}^N \frac{\lambda_i}{(\lambda_i + \epsilon)^2} |\mathbf{V}_i^+ \mathbf{A}|^2}{\left( \sum_{i=1}^N \frac{1}{\lambda_i + \epsilon} |\mathbf{V}_i^+ \mathbf{A}|^2 \right)^2}$$

There are many approaches to determine the amount of white noise to add in the WNC processing. In this study the following algorithm is used. For each steering direction, the MVDR white noise processing gain and the MVDR output are calculated. If the white noise processing gain falls below a pre-selected constraining

value, the MVDR processing is used. If the white noise processing gain is above the constraining value, an amount of white noise that equals the MVDR output is added in the WNC processing.

In this paper all adaptive beamforming (ABF) refer to WNC adaptive beamforming with a 3-dB constraint. The phone-space adaptive beamforming (PS\_ABF) refers to the WNC adaptive beamforming performing on the hydrophone sample-matrix with a calculated phone steering vector.

#### 4. Subarray Beam-space Adaptive Beamforming (SABS\_ABF)

Subarray beam-space adaptive beamforming is a two-stage processing. It has been studied [4] with emphasis on its advantage of rank reduction for fast adaptation. In this study, our emphasis is on using the updated AEL to compensate the temporal variation of a received signal due to rapid changes in array shape. Figure 4 shows the

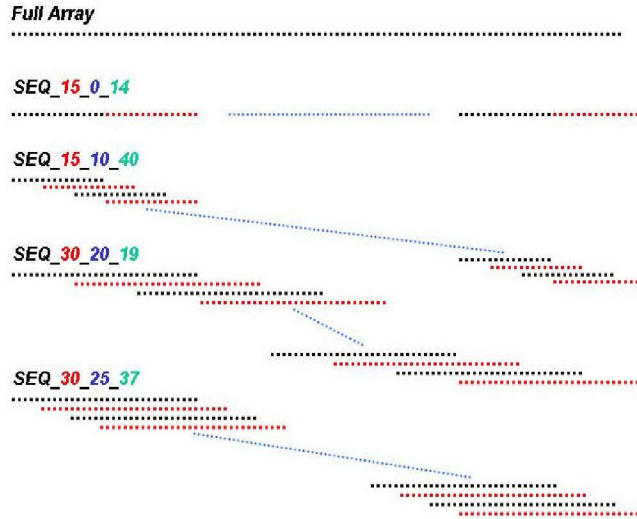

Figure 4: Subarray configurations used in this study

full-array and four Subarray configurations that are considered in this study. The notations in each configuration are SEQuential, number of hydrophones in each subarray, subarray overlap, and number of subarrays. For example, SEQ\_15\_10\_40 is a configuration of 15-phone subarrays in a sequential format with overlap of 10 phones and a total of 40 subarrays.

Let  $\{1, 2, \dots, S\}$  be a set of hydrophones in one of the subarrays, the range-focus steering vector of the  $m^{\text{th}}$  subarray at search cell  $r$  is calculated as

$$A_m^+(r, t) = \frac{1}{\sqrt{S}} \begin{bmatrix} e^{-i\varphi_{m,1}(t)} & e^{-i\varphi_{m,2}(t)} & \dots & e^{-i\varphi_{m,S}(t)} \end{bmatrix}$$

where

$$\varphi_{m,s}(t) = 2\pi f |r - r_{m,s}(t)| / c$$

$c$  is the sound speed and  $r_{m,s}(t)$  is the measured position of the  $s^{\text{th}}$  hydrophone in the  $m^{\text{th}}$  subarray at time  $t$ . In the first stage SABS\_ABF performs subarray conventional beamforming using the updated subarray steering vectors and transforms the phone-space sample-matrix into a beam-space sample-matrix

$$(r, t) = \begin{bmatrix} b_1(r, t) & b_1(r, t + \Delta t) & \dots & b_1(r, t + (K-1)\Delta t) \\ b_2(r, t) & b_2(r, t + \Delta t) & \dots & b_2(r, t + (K-1)\Delta t) \\ \vdots & \vdots & \vdots & \vdots \\ b_M(r, t) & b_M(r, t + \Delta t) & \dots & b_M(r, t + (K-1)\Delta t) \end{bmatrix}$$

where

$$b_m(r, t) = A_m^+(r, t) \cdot X_m(t)$$

is the conventional beamformer response of the  $m^{\text{th}}$  subarray and  $X_m(t)$  is the data vector of the  $m^{\text{th}}$  subarray at time  $t$ . In the first stage SABS\_ABF also transforms the phone-space steering vector into a beam-space steering vector. Let

$$\tilde{A}_b^+(r, t) = [\tilde{A}_{b,1}^*(r, t) \quad \tilde{A}_{b,2}^*(r, t) \quad \dots \quad \tilde{A}_{b,M}^*(r, t)]$$

where

$$\tilde{A}_{b,m} = A_m^+(r, t) \cdot A_m(r, t)$$

the beam-space steering vector is calculated as

$$A_b(r, t) = \tilde{A}_b(r, t) / |\tilde{A}_b(r, t)|$$

For a constant amplitude non-fading signal, the beam-space steering vector is simply a unity vector with a uniform weight of  $1/\sqrt{M}$  on each subarray. In the second stage SABS\_ABF performs white-noise-constrained adaptive beamforming described in Section 3 with the calculated beam-space sample-matrix and the beam-space steering vector.

#### 5. Simulation Results

The simulation geometry has been described in Section 1 and a 0-dB white noise is injected in all simulations. For target-only, Figure 5 shows the WNC ABF responses along the target track. Assuming array is straight (No AEL), PS\_ABF experiences significant mismatch loss during turn. When the measured mean AEL is used, the mismatch loss in PS\_ABF is reduced, but there still is more than 5 dB signal spread loss in the turn due to rapid changes in array shape within the 30-s processing interval. SABS\_ABF shows success in holding the target through the turn. For target-only, Figures 6 and 7 show the bearing-time responses (BTRs) resulted from PS\_ABF and SABS\_ABF for a 0-dB target. The results show that SABS\_ABF not only reduces the signal spread loss but also reduces the angular spread of the target during the turn.

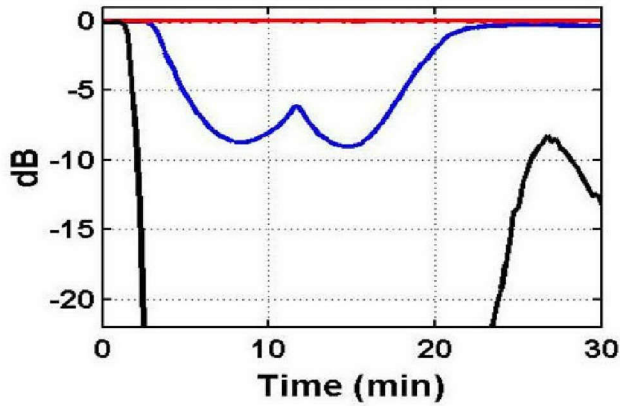

Figure 5: WNC ABF responses along target track, black curve is result of PS\_ABF without AEL, blue curve is result of PS\_ABF with mean AEL, and red curve is result of SABS\_ABF for SEQ\_15\_10\_41 configuration.

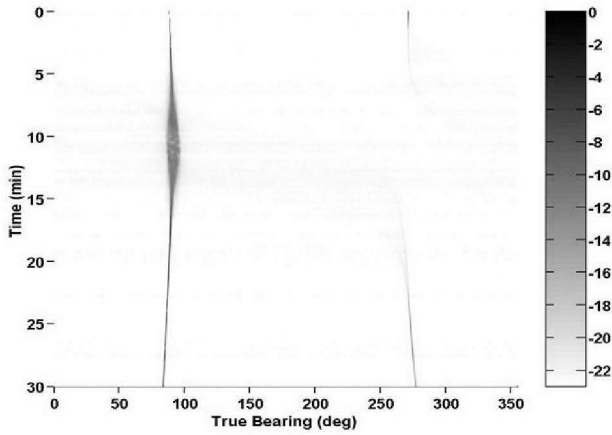

Figure 6: BTR of PS\_ABF for a 0-dB target

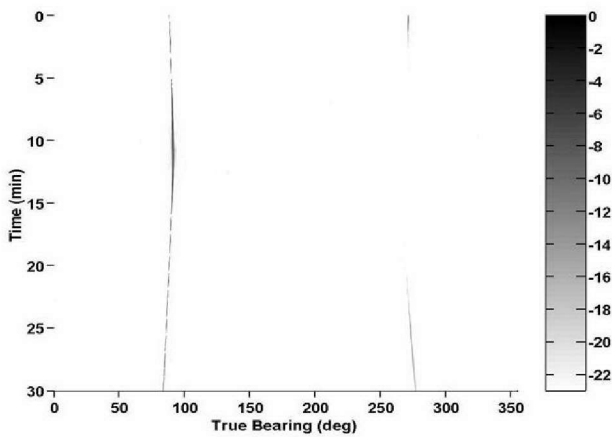

Figure 7: BTR of SABS\_ABF with SEQ\_15\_10\_41 configuration for a 0-dB target

Figures 8 and 9 show the WNC ABF results for a weak target in a stressful environment. In this case, the target power is set at -18 dB, the own-ship and the other two interferers are set at 15 dB. The PS\_ABF result shows that target is lost in the interference in turn. The SABS\_ABF result shows a continuous target-holding through turn under such stressful condition.

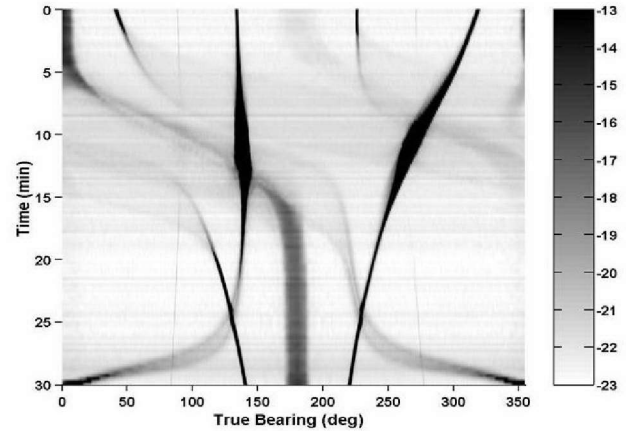

Figure 8: BTR of PS\_ABF for a weak target in a stressful environment

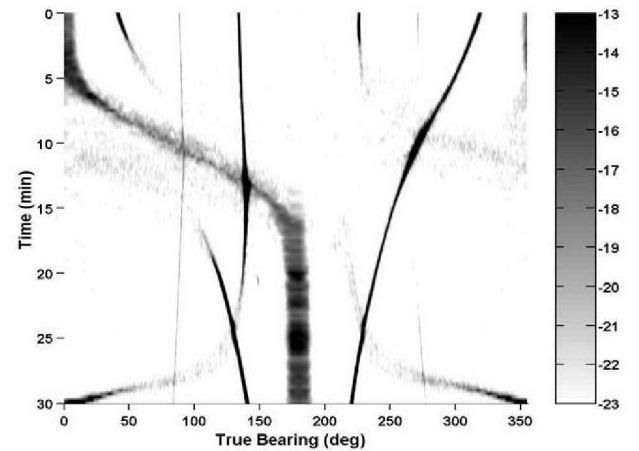

Figure 9: BTR of SABS\_ABF with SEQ\_15\_10\_41 configuration for a weak target in a stressful environment

Figures 7 and 9 are results of SABS\_ABF with SEQ\_15\_10\_40 subarray configuration where two consecutive subarrays have a 66% overlap and the centers are shifted by a distance of 5-phone spacing. Figure 10 shows result of SABS\_ABF with SEQ\_15\_0\_14 configuration where two consecutive subarrays have no overlap and the centers are shifted by a distance of 15-phone spacing. It shows that overlapping the subarrays provides better suppression of signal sidelobes. Figure 11

shows result of SABS\_ABF with SEQ\_30\_10\_37 configuration where two consecutive subarrays have a 66% overlap and the centers are shifted by a distance of 10-phone spacing. Signal sidelobes are still noticeable in this case. Figure 12 shows result of SABS\_ABF with SEQ\_30\_5\_37 configuration where two consecutive subarrays have a 83% overlap and the centers are shifted by a distance of 5-phone spacing. Signal sidelobes are well behaved as seen in SEQ\_15\_5\_40. This says that the distance between the centers of two consecutive subarrays is an important parameter for SABS\_ABF processing.

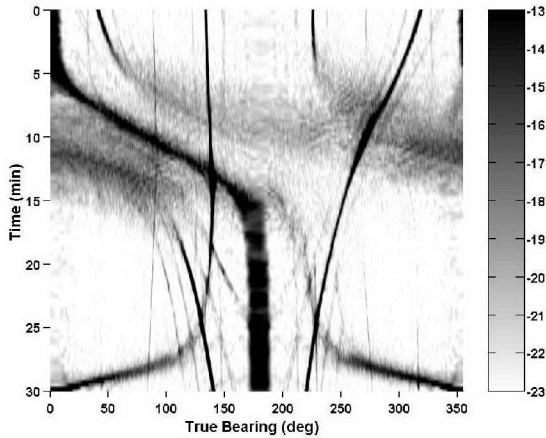

Figure 10: BTR of SABS\_ABF with SEQ\_15\_0\_14 configuration for a weak target in a stressful environment

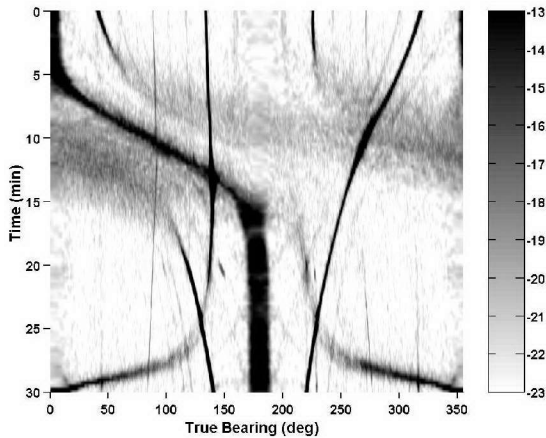

Figure 11: BTR of SABS\_ABF with SEQ\_30\_10\_19 configuration for a weak target in a stressful environment

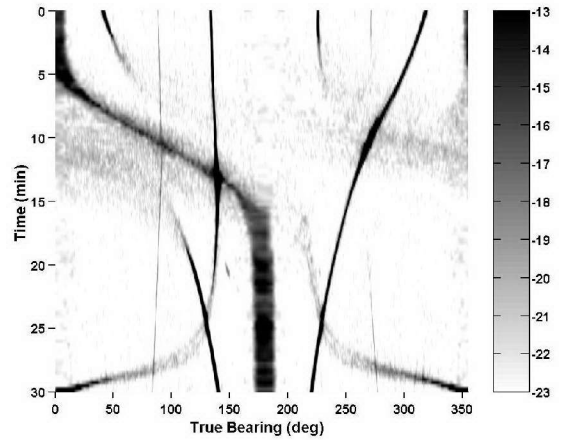

Figure 12: BTR of SABS\_ABF with SEQ\_30\_5\_37 configuration for a weak target in a stressful environment

## 6. Summary

In this paper we address the issue of signal spread loss in a phone-space sample-matrix due to rapid changes of array shape within a processing interval when array is in maneuvering. The loss significantly affects detection and tracking of a weak target. SBAS\_ABF uses the updated AEL to compensate the temporal variation of the received signal so that signal in the beam-space sample-matrix becomes stationary during array maneuvering. It is shown that SABS\_ABF not only has the advantage of reducing rank for fast adaptation, but also improves target detection and tracking through severe array maneuvering.

## Reference:

- [1]“Beamspace Adaptive beamforming for Hydrodynamic Towed Array Self-Noise Cancellation” V. E. Premus, S. M. Kogon, and J. Ward, ASAP 2001
- [2]“Model Based Array Element Localization for Single and Multiline Towed Arrays”, J. P. Ianniello, R. B. Evans, and B. Sperry, ASAP 2003
- [3]“Robust Adaptive Beamforming,” H. Cox, IEEE Trans. On Acoustics, Speech and Signal Processing, vol. ASSP 35, pp. 1365-1376, Oct. 1987.
- [4]“Sub-Aperture Beamspace Adaptive Processing,” H. Freese, B. Sperry, and K. Votow, ASAP 2003.

# *Subarray Beam-Space Adaptive Beamforming for A Dynamic Long Towed-Array*

*Dr. Yung P. Lee, SAIC/McLean*

*Herb Freese, SAIC/McLean*

*William W. Lee, Univ. of Maryland*

*17 March, 2004*

*Presented at ASAP 2004, MIT Lincoln Lab*

# OUTLINE

- **Background & Issues**
- **White-Noise-Constrained Adaptive Beamforming (WNC\_ABF)**
- **Subarray Beam-Space Adaptive Beamforming (SABS\_ABF)**
- **Simulation Results**
- **Summary**

# ***Issues of Long Towed-Array Through A Dynamic Maneuver***

- ***Flow Noise***

- *“Beam-space Adaptive beamforming for Hydrodynamic Towed Array Self-Noise Cancellation” V. E. Premus, S. M. Kogon, and J. Ward, ASAP 2001*

- ***Change in Array Shape – Array Element Location (AEL)***

- *“Model Based Array Element Localization for Single and Multiline Towed Arrays”, J. P. Ianniello, R. B. Evans, and B. Sperry, ASAP 2003*

- ***Signal Spread in Phone-Space Sample-Matrix***

- ***Signal Structure Changes Within Processing Interval Due to Array Motion***
  - ***Signal Coherence Loss among Hydrophones***
  - ***Spread in Singular-Value/Singular Vector or Eigenvalue/Eigenvector***

# Simulation Geometry – 180° Turn

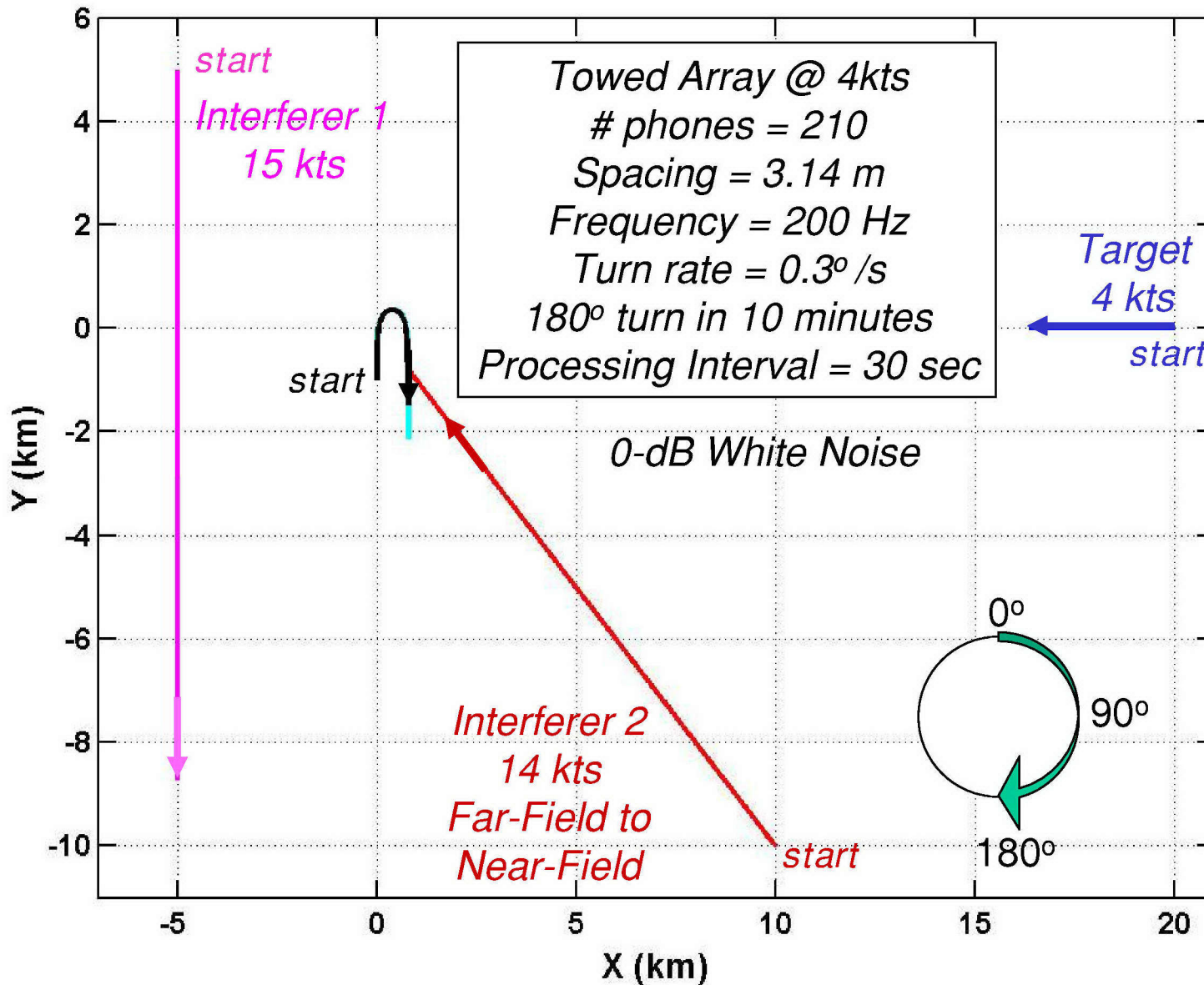

# Signal Coherence Loss Through Turn

Target Only, Processing Interval = 30 sec

Signal Coherence  
relative to phone 1

$$SC_n(t) = \frac{\left| \sum_{k=0}^{N-1} x_1^*(t+k\Delta t) \cdot x_n(t+k\Delta t) \right|^2}{\sum_{k=0}^{N-1} |x_1(t+k\Delta t)|^2 \cdot \sum_{n=0}^{N-1} |x_n(t+k\Delta t)|^2}$$

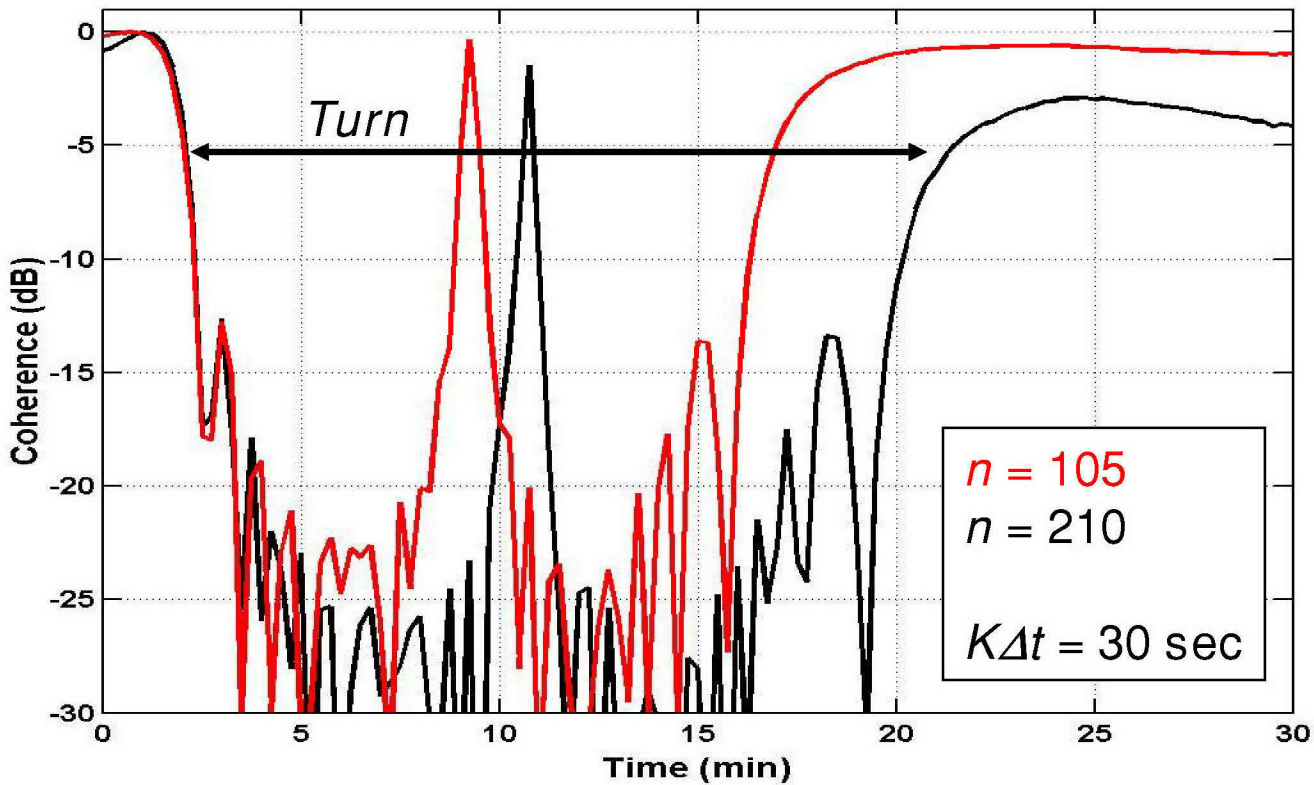

# Phone-Space Singular-Value Spread Through Turn

Target Only, Processing Interval = 30 sec

Phone-Space Sample-Matrix

$$= \begin{bmatrix} x_1(t) & x_1(t+\Delta t) & x_1(t+2\Delta t) & \dots & x_1(t+(K-1)\Delta t) \\ x_2(t) & x_2(t+\Delta t) & x_2(t+2\Delta t) & \dots & x_2(t+(K-1)\Delta t) \\ \vdots & \vdots & \vdots & \vdots & \vdots \\ x_N(t) & x_N(t+\Delta t) & x_N(t+2\Delta t) & \dots & x_N(t+(K-1)\Delta t) \end{bmatrix}$$

Singular Value Decomposition (SVD)

$$X = V + \Lambda U$$

$$\Lambda = \begin{bmatrix} \sqrt{\lambda_1} & 0 & \dots & 0 \\ 0 & \sqrt{\lambda_2} & \dots & 0 \\ \vdots & \vdots & \ddots & \vdots \\ 0 & 0 & \dots & \sqrt{\lambda_N} \end{bmatrix}$$

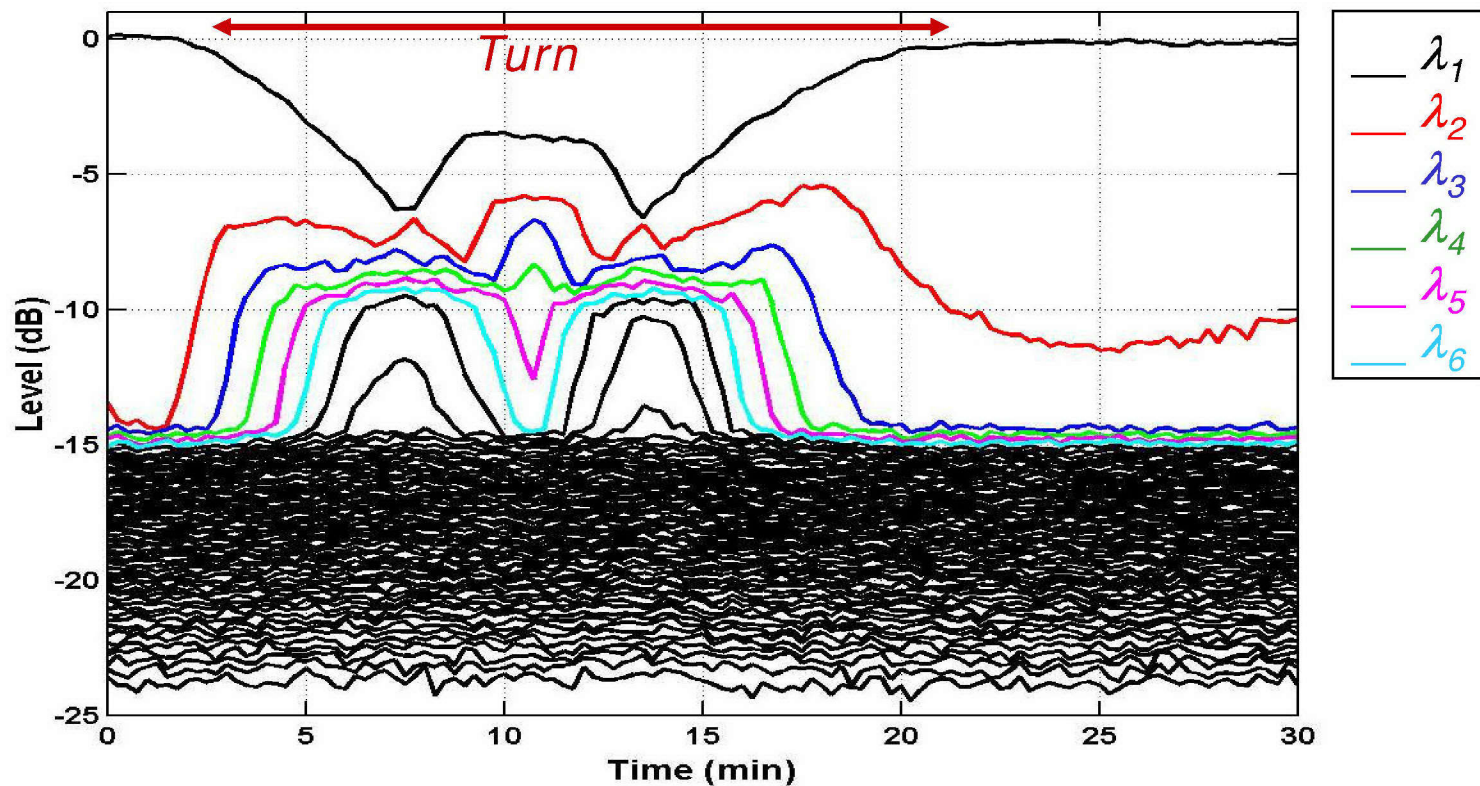

# OUTLINE

- *Background & Issues*
- *White-Noise-Constrained Adaptive Beamforming (WNC\_ABF)*
- *Subarray Beam-Space Adaptive Beamforming (SABS\_ABF)*
- *Simulation Results*
- *Summary*

# White-Noise-Constrained Adaptive Beamforming (WNC\_ABF)

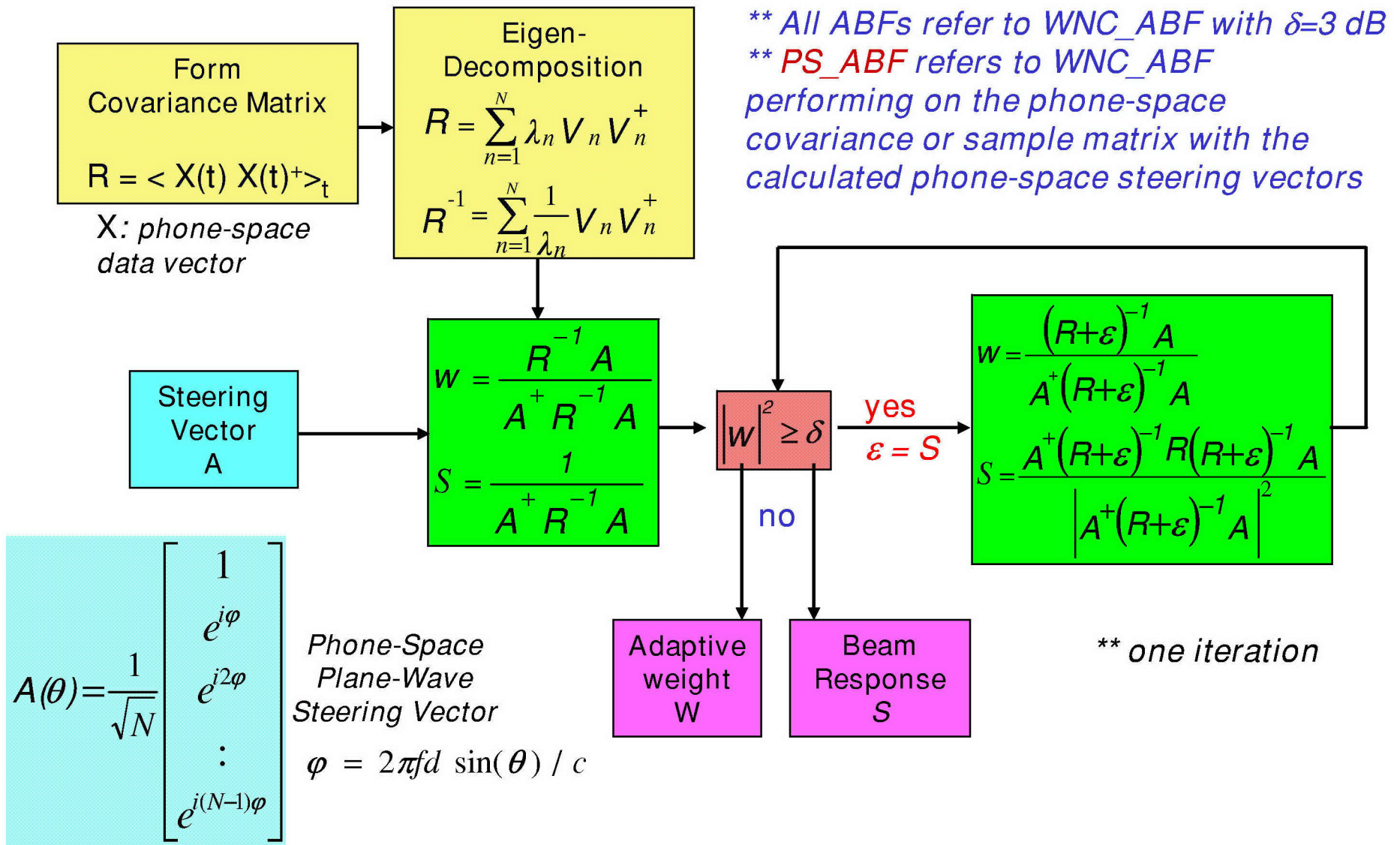

# WNC\_ABF - Alternatives

Phone-Space Sample-Matrix

$$= \begin{bmatrix} x_1(t) & x_1(t+\Delta t) & x_1(t+2\Delta t) & \dots & x_1(t+(K-1)\Delta t) \\ x_2(t) & x_2(t+\Delta t) & x_2(t+2\Delta t) & \dots & x_2(t+(K-1)\Delta t) \\ \vdots & \vdots & \vdots & \vdots & \vdots \\ x_N(t) & x_N(t+\Delta t) & x_N(t+2\Delta t) & \dots & x_N(t+(K-1)\Delta t) \end{bmatrix}$$

Phone-Space Range-Focus Steering Vector

$$\varphi_n = 2\pi f |r - r_n| / c$$

$$A(r) = \frac{1}{\sqrt{N}} \begin{bmatrix} e^{i\varphi_1} \\ e^{i\varphi_2} \\ \vdots \\ e^{i\varphi_N} \end{bmatrix}$$

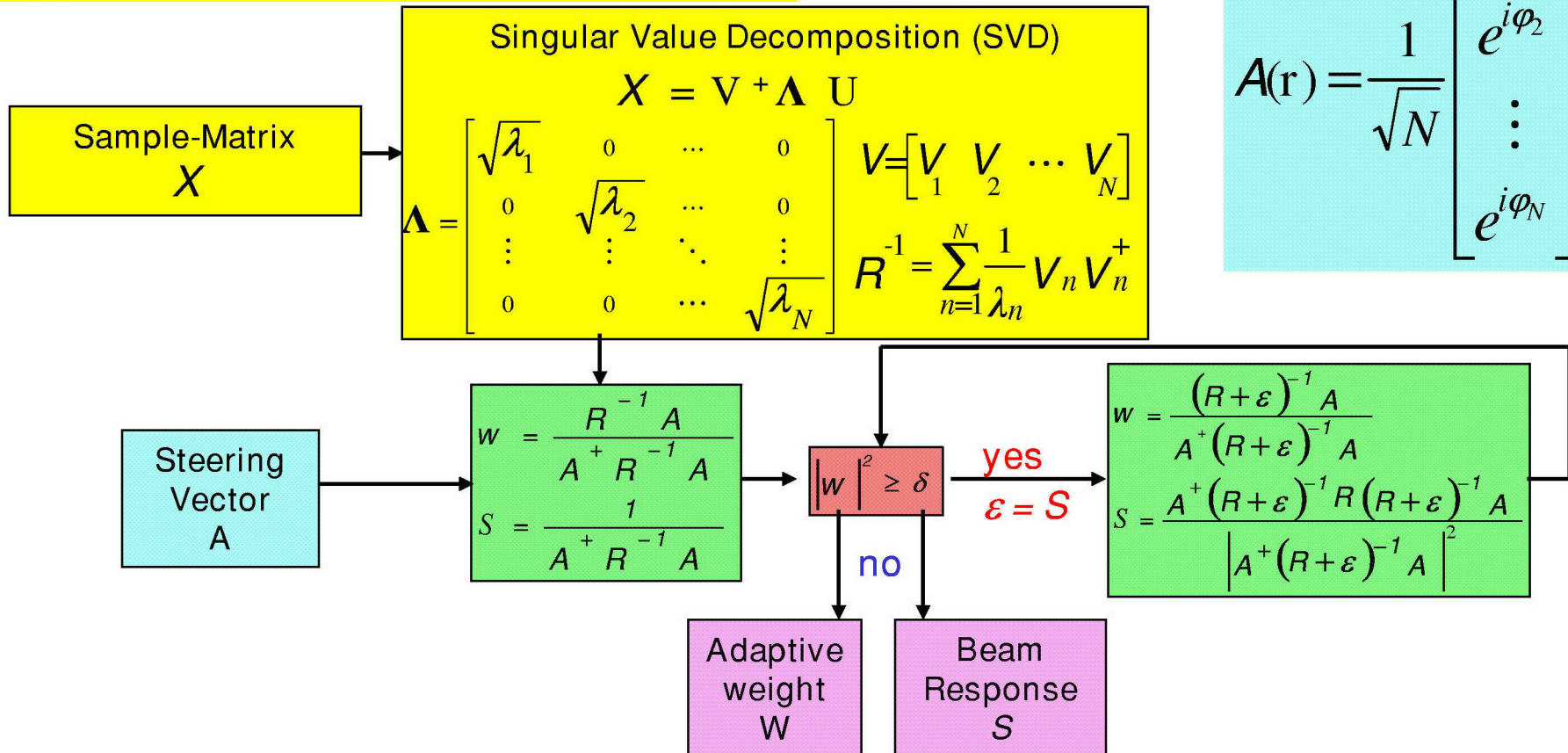

# OUTLINE

- **Background & Issues**
- **White-Noise-Constrained Adaptive Beamforming (WNC\_ABF)**
- **Subarray Beam-Space Adaptive Beamforming (SABS\_ABF)**
  - *“Sub-Aperture Beamspace Adaptive Processing” H. Freese, B. Sperry, and K. Votaw, ASAP 2003*
    - *emphasized on reduced rank and fast adaptation*
  - *This study emphasizes on using updated AEL to compensate signal structure changes from snapshot to snapshot due to rapid changes in array shape so that signal in the beam-space becomes “stationary”*
    - *Coherence across subarrays*
    - *Less spread in singular-value or eigen-decomposition*
- **Simulation Results**
- **Summary**

# The 1<sup>st</sup> Stage of SABS\_ABF

## Subarray CBF with Updated AEL

$$\varphi_n(t) = 2\pi f |\mathbf{r} - \mathbf{r}_n(t)| / c \quad \mathbf{r}_n(t) \text{ is the updated AEL}$$

$$\tilde{\mathbf{A}}(\mathbf{r}, t) = \begin{bmatrix} e^{i\varphi_1(t)} & e^{i\varphi_1(t+\Delta t)} & \dots & e^{i\varphi_1(t+(K-1)\Delta t)} \\ e^{i\varphi_2(t)} & e^{i\varphi_2(t+\Delta t)} & \dots & e^{i\varphi_2(t+(K-1)\Delta t)} \\ \vdots & \vdots & \vdots & \vdots \\ e^{i\varphi_N(t)} & e^{i\varphi_N(t+\Delta t)} & \dots & e^{i\varphi_N(t+(K-1)\Delta t)} \end{bmatrix}$$

Phone-Space Sample-Matrix

$$\mathbf{x}(t) = \begin{bmatrix} x_1(t) & x_1(t+\Delta t) & \dots & x_1(t+(K-1)\Delta t) \\ x_2(t) & x_2(t+\Delta t) & \dots & x_2(t+(K-1)\Delta t) \\ \vdots & \vdots & \vdots & \vdots \\ x_N(t) & x_N(t+\Delta t) & \dots & x_N(t+(K-1)\Delta t) \end{bmatrix}$$

Subarray Steering Vector

$$\mathbf{m}(\mathbf{r}, t) = \tilde{\mathbf{m}}_{m,\{s\}}(\mathbf{r}, t) / \sqrt{S}$$

Subarray Data Vector

$$\mathbf{m}(t) = \tilde{\mathbf{m}}_{m,\{s\}}(t)$$

$$\tilde{\mathbf{A}}_b(\mathbf{r}, t) = \begin{bmatrix} \tilde{A}_{b,1}(t) & \tilde{A}_{b,1}(t+\Delta t) & \dots & \tilde{A}_{b,1}(t+(K-1)\Delta t) \\ \tilde{A}_{b,2}(t) & \tilde{A}_{b,2}(t+\Delta t) & \dots & \tilde{A}_{b,2}(t+(K-1)\Delta t) \\ \vdots & \vdots & \vdots & \vdots \\ \tilde{A}_{b,M}(t) & \tilde{A}_{b,M}(t+\Delta t) & \dots & \tilde{A}_{b,M}(t+(K-1)\Delta t) \end{bmatrix}$$

$$\mathbf{b}(\mathbf{r}, t) = \begin{bmatrix} b_1(t) & b_1(t+\Delta t) & \dots & b_1(t+(K-1)\Delta t) \\ b_2(t) & b_2(t+\Delta t) & \dots & b_2(t+(K-1)\Delta t) \\ \vdots & \vdots & \vdots & \vdots \\ b_M(t) & b_M(t+\Delta t) & \dots & b_M(t+(K-1)\Delta t) \end{bmatrix}$$

Beam-Space Sample-Matrix

Beam-Space Steering Vector

$$\tilde{A}_{b,m}(t) = \mathbf{m}^+(\mathbf{r}, t) \cdot \tilde{\mathbf{m}}_m(\mathbf{r}, t)$$

$$\mathbf{A}_b(\mathbf{r}, t) = \tilde{\mathbf{A}}_b(\mathbf{r}, t) / \sqrt{M}$$

Subarray CBF Response

$$b_m(t) = \mathbf{m}^+(\mathbf{r}, t) \cdot \mathbf{m}_m(t)$$

## The 2<sup>nd</sup> Stage of SABS\_ABF

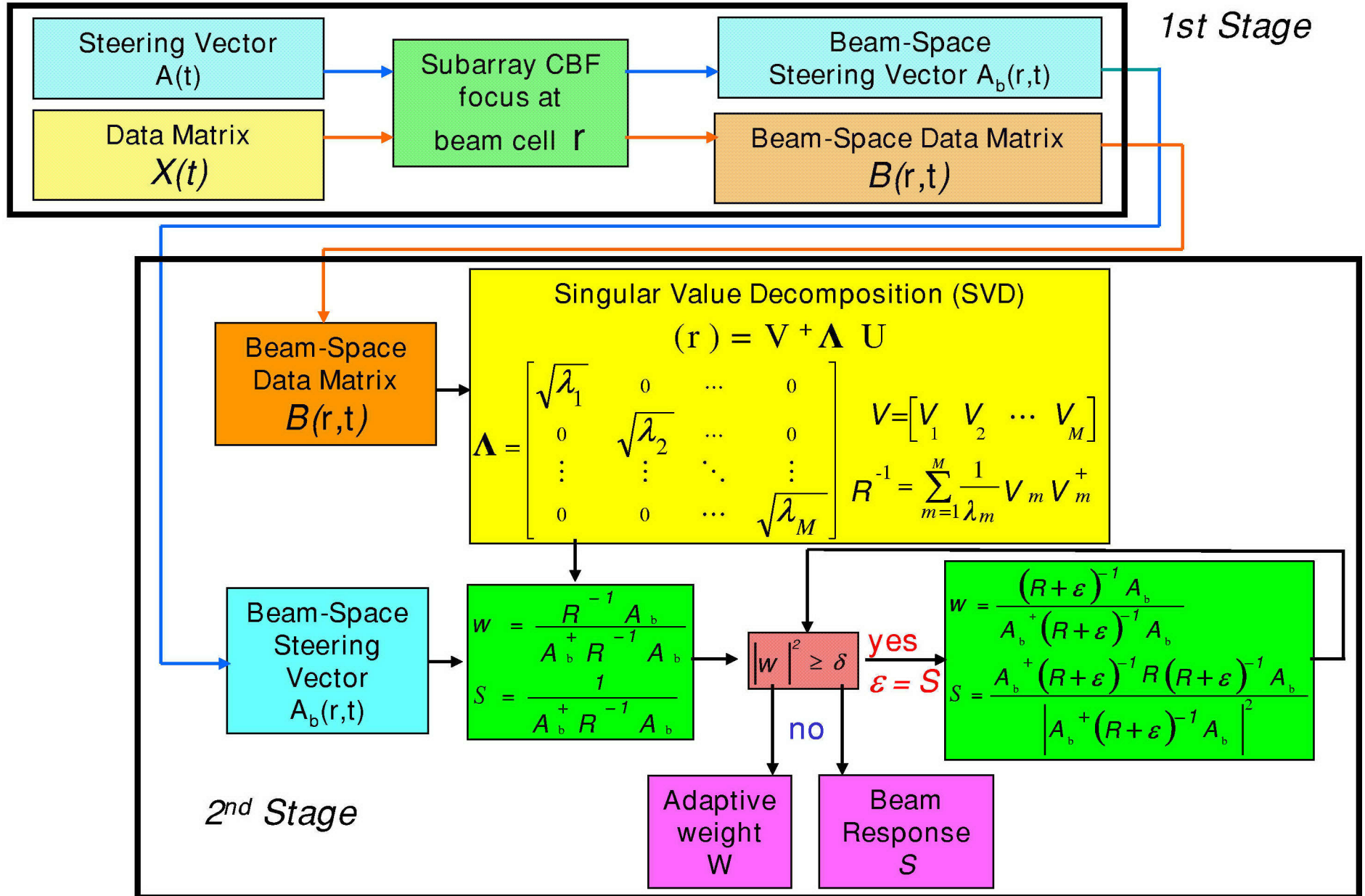

# SubArray Selection

Sequential\_ # phones in subarray \_overlap\_ # subarrays

Full Array



SEQ\_15\_0\_14 no overlap, 15-phone spacing between two consecutive subarray centers



SEQ\_15\_10\_40

66% overlap, 5-phone spacing between two consecutive subarray centers

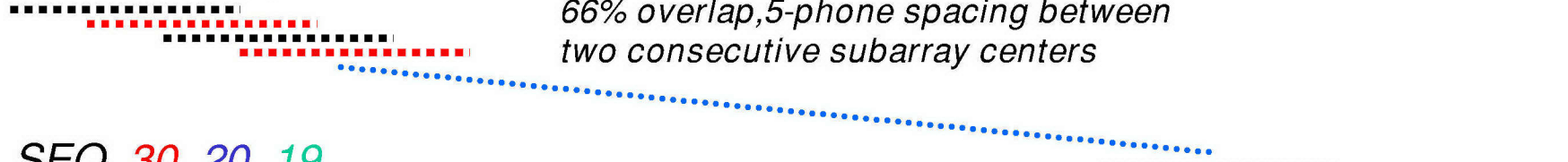

SEQ\_30\_20\_19

66% overlap, 15-phone spacing between two consecutive subarray centers

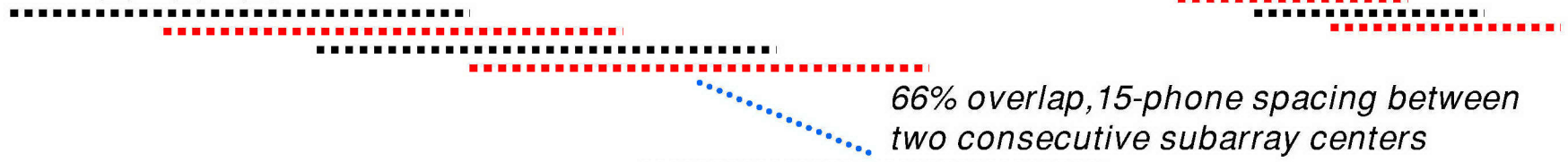

SEQ\_30\_25\_37

83% overlap, 5-phone spacing between two consecutive subarray centers

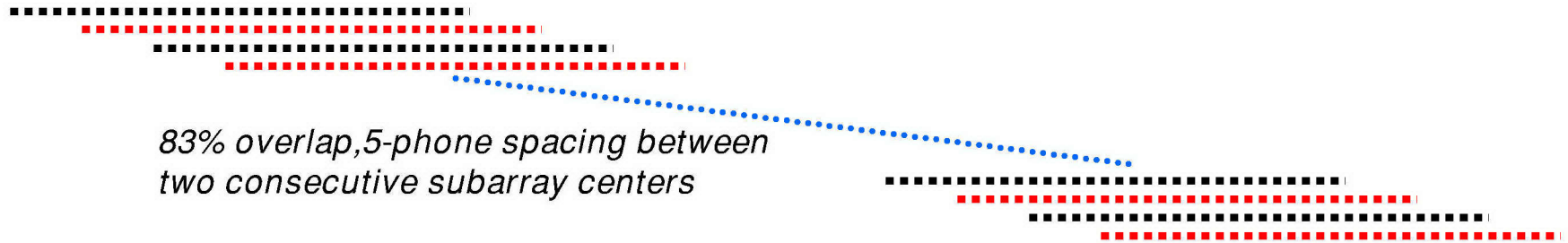

# OUTLINE

- *Background & Issues*
- *White-Noise-Constrained Adaptive Beamforming (WNC\_ABF)*
- *Subarray Beam-Space Adaptive Beamforming (SABS\_ABF)*
- *Simulation Results*
- *Summary*

# Beam-Time Responses Along Target Track

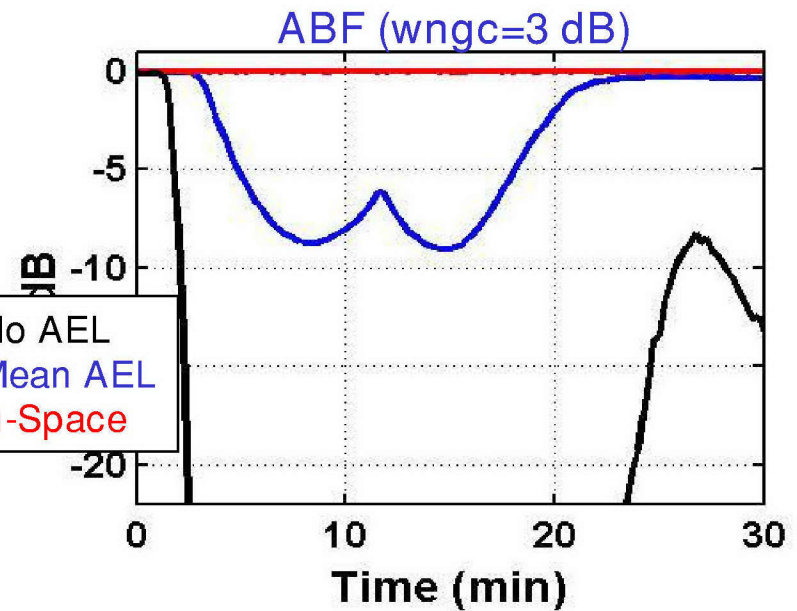
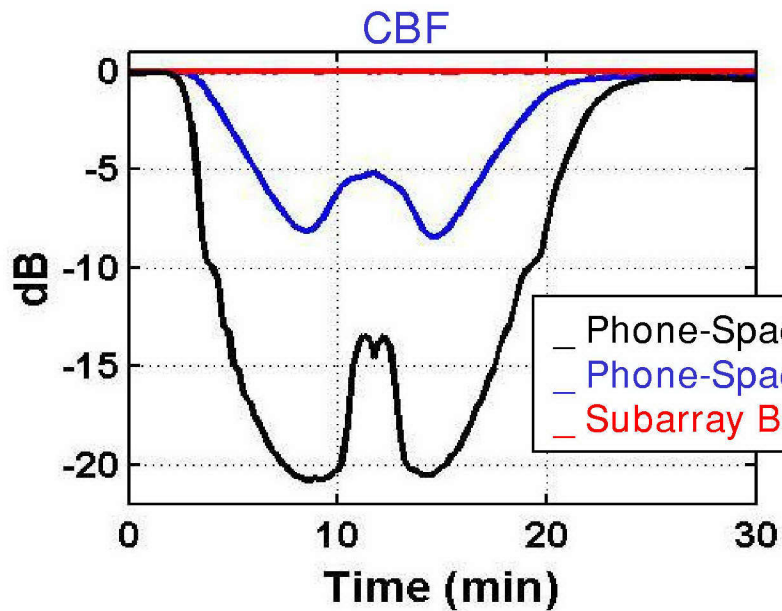
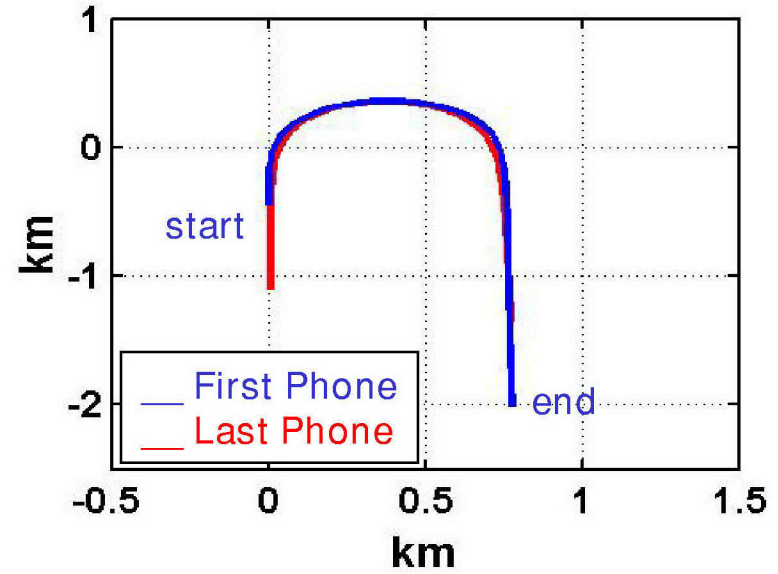
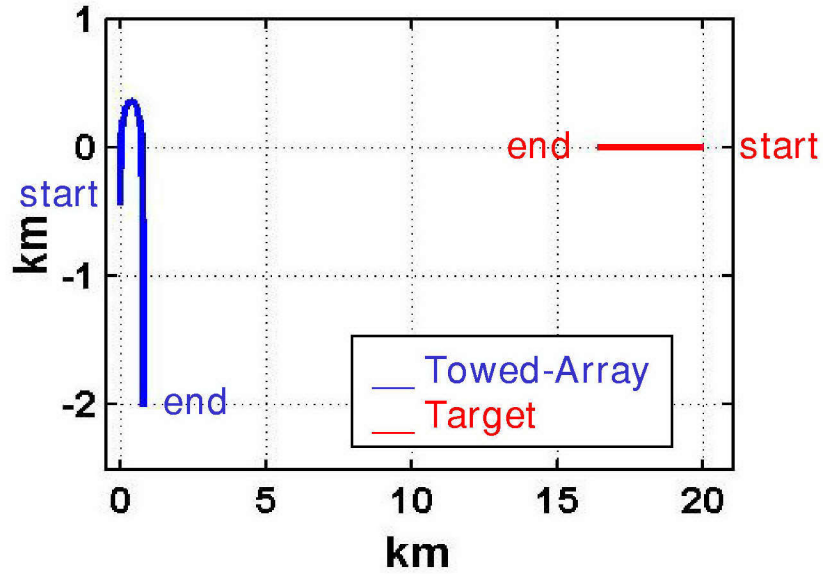

# Bearing-Time Responses

Target Only (0 dB)

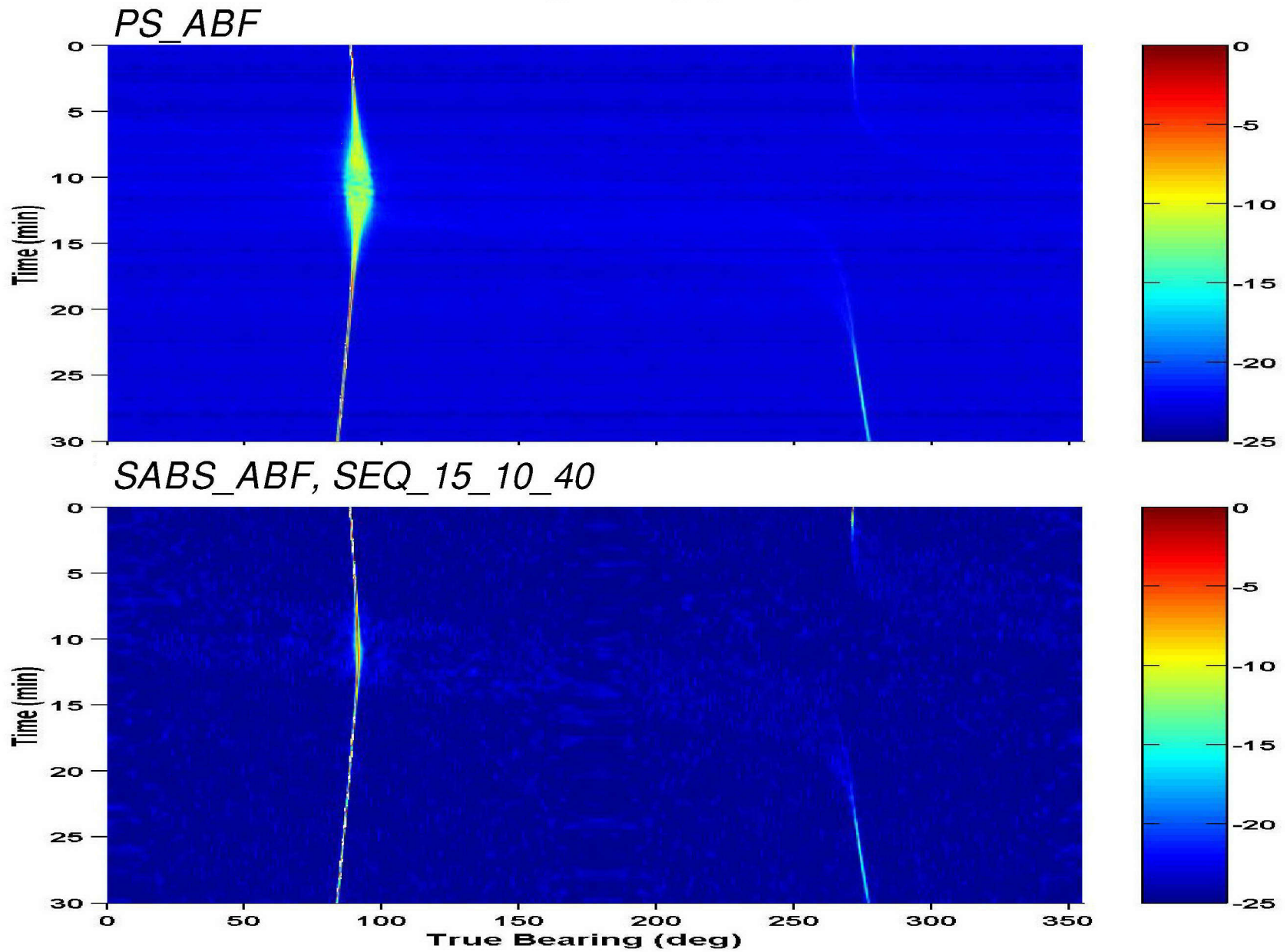

# Bearing-Time Responses

Weak Target (-18 dB) + Own-ship (15 dB)

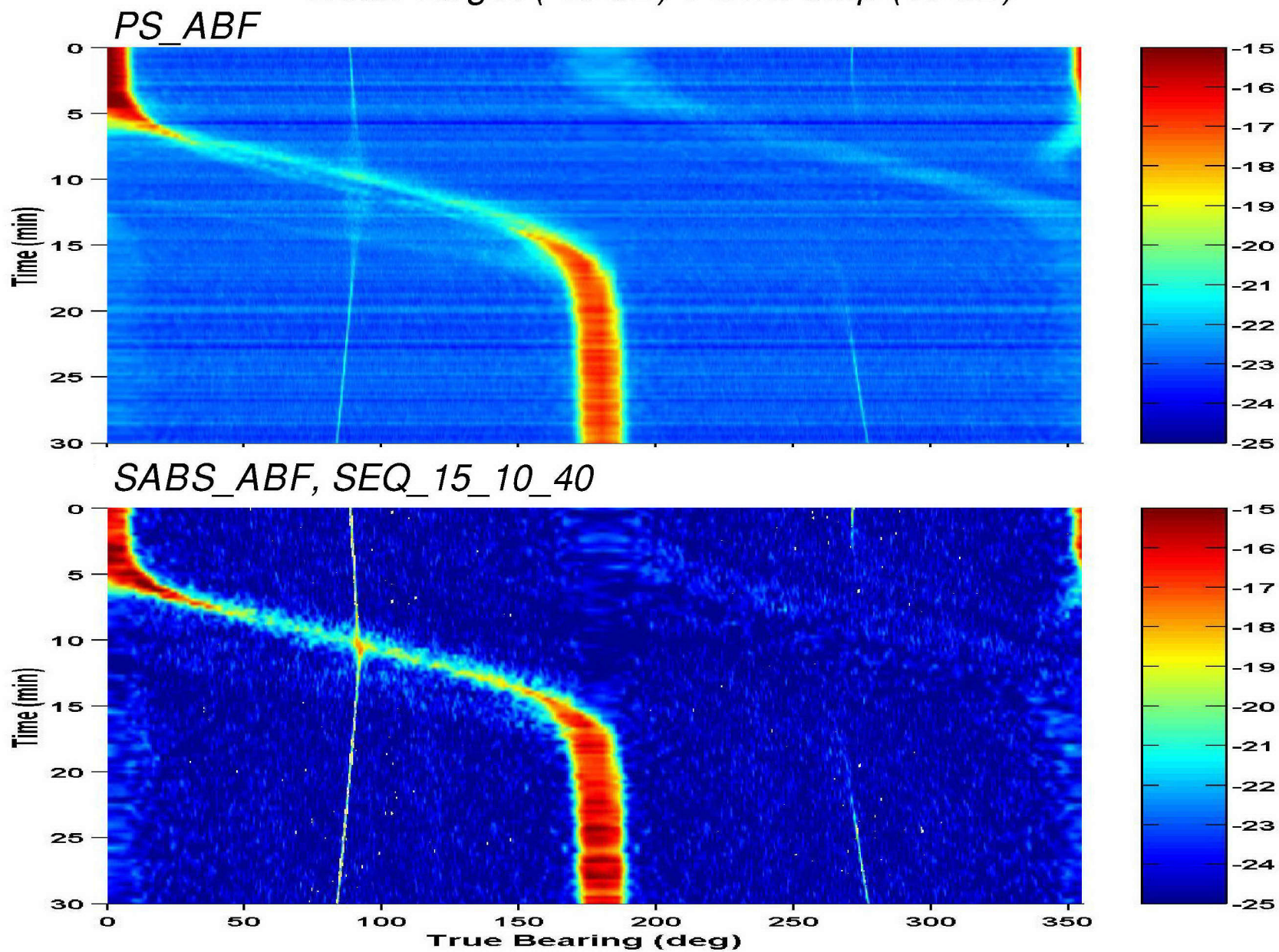

# Bearing-Time Responses

Weak Target (-18 dB) + Own-ship (15 dB) + Interferers (15 dB)

PS\_ABF

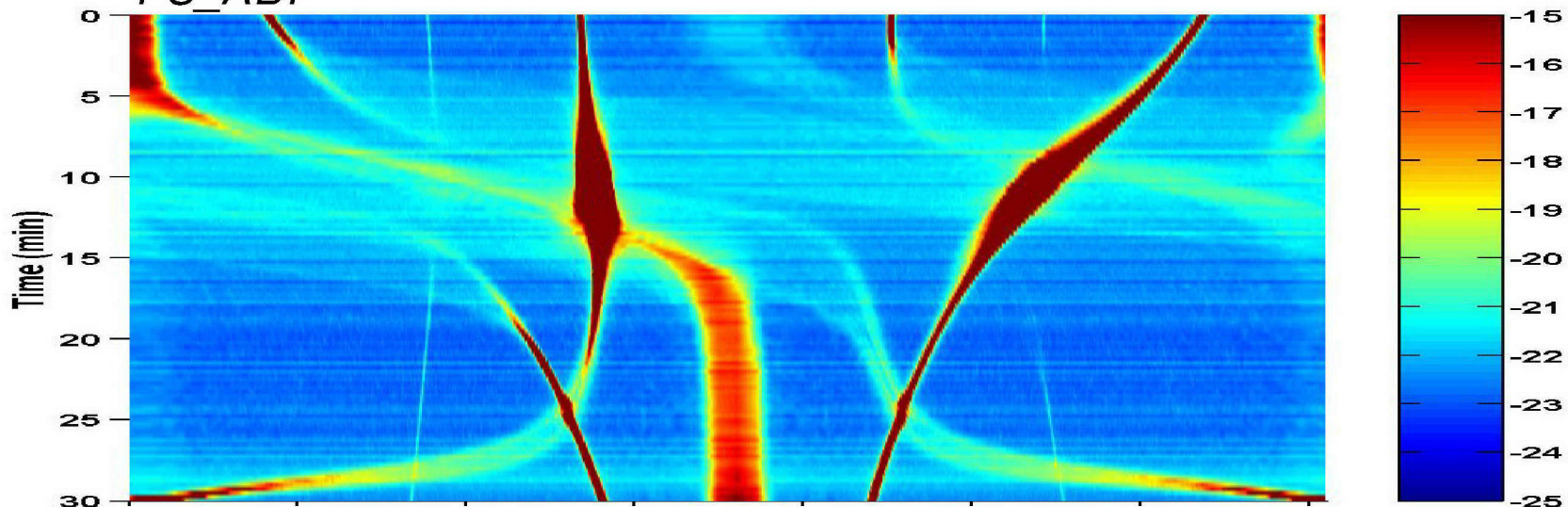

SABS\_ABF, SEQ\_15\_10\_40

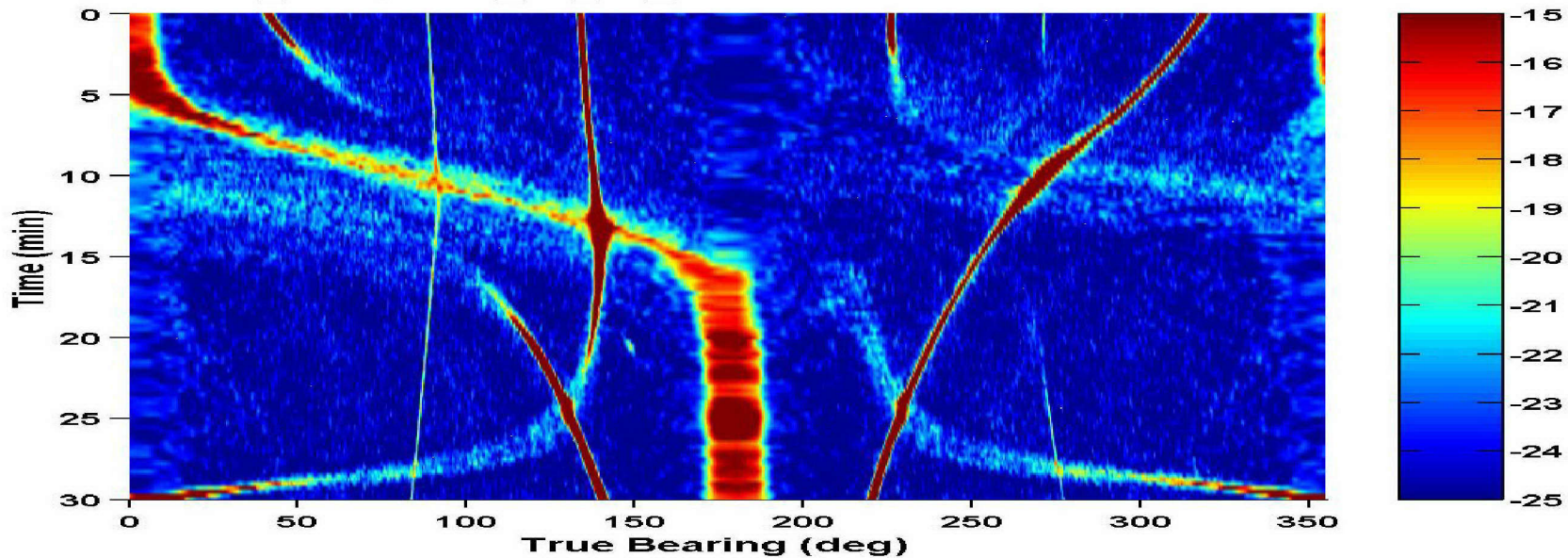

# SABS\_ABF Bearing-Time Responses

Weak Target (-18 dB) + Own-ship (15 dB) + Interferers (15 dB)

SEQ\_15\_0\_14, no overlap

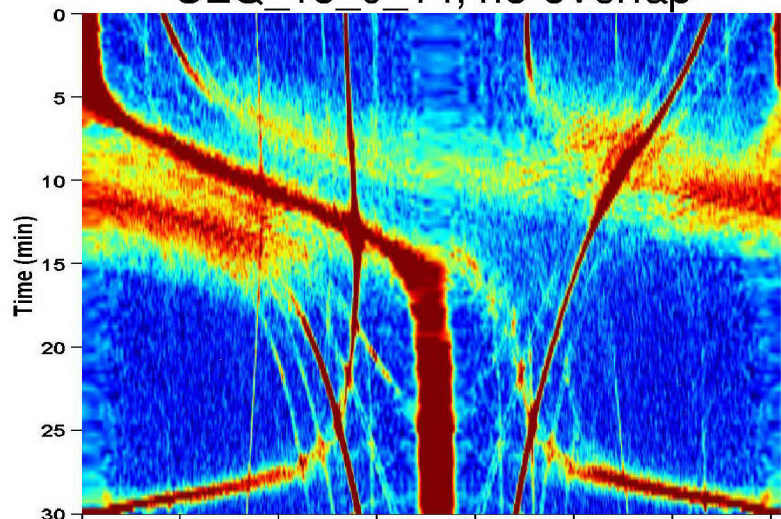

SEQ\_15\_10\_40, 66% overlap, step=5

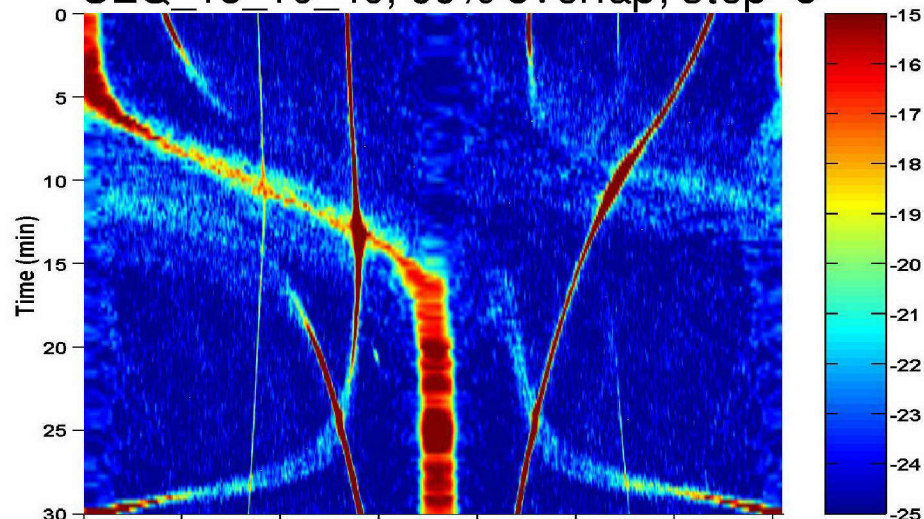

SEQ\_30\_20\_19, 66% overlap, step=10

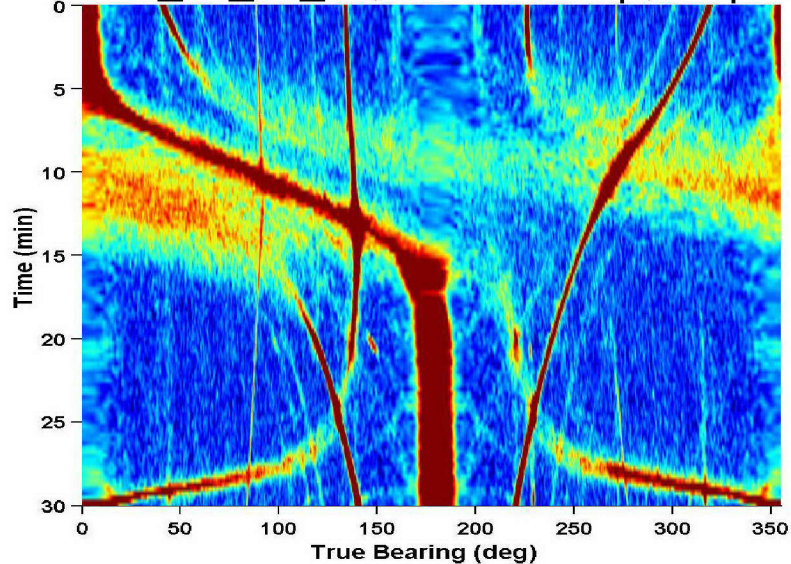

SEQ\_30\_25\_37, step=5

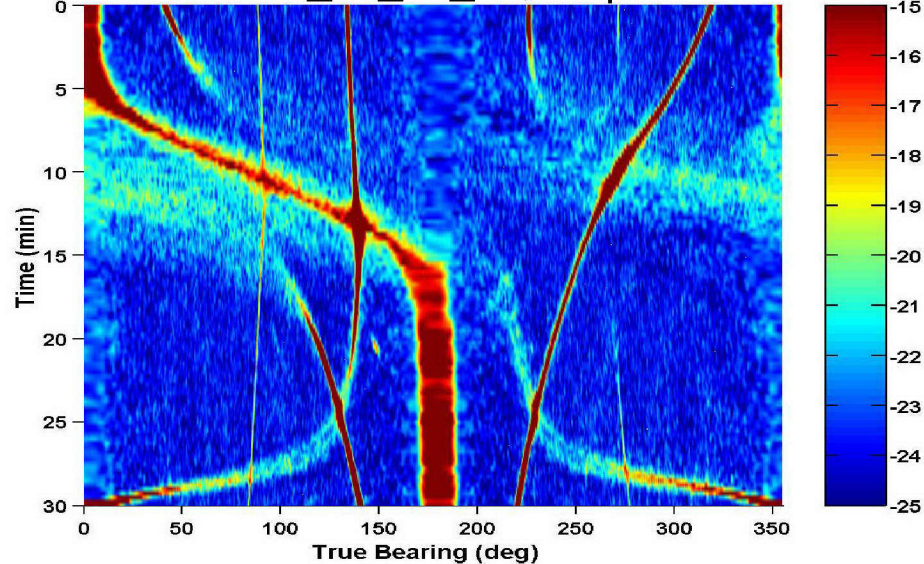

# **SUMMARY**

- ***Subarray Beam-Space ABF with updated AEL compensation recovers signal spreading loss and provides continuous target holding through array maneuvering.***
- ***Beam-space ABF involves extensive computation***
  - ***Try Fast ABF such as Multi-Stage Wiener Filter***
- ***What's the rule-of-thumb for subarray selection?***
  - ***Distance between two consecutive subarray centers is an important parameter.***
- ***Is there significant benefit for ABF-ABF vs CBF-ABF?***