

A Novel Technique for Broadband Singular Value Decomposition

John McWhirter and Paul D. Baxter

QinetiQ, Ltd.

phone: 44 1684 895384

email: mcwhirter@signal.qinetiq.com

email: pbaxter@signal.qinetiq.com

Abstract The singular value decomposition (SVD) is a very important tool for narrowband adaptive sensor array processing. The SVD decorrelates the signals received from an array of sensors by applying a unitary matrix of complex scalars, which serve to modify the signals in phase and amplitude. Because the transformation is unitary, the associated singular values represent the true energy associated with each of the decorrelated components so the signal and noise subspaces may sometimes be separated.

In broadband applications, or a situation in which narrowband signals have been convolutively mixed, the received signals cannot be represented in terms of phase and amplitude. Instantaneous decorrelation using a unitary matrix is no longer sufficient to separate them. It is necessary to impose decorrelation, not just at the same time instant for all signals, but over a suitably chosen range of relative time delays. This is referred to as strong decorrelation.

Implementing strong decorrelation involves the application of a matrix of suitably chosen FIR filters and if each filter is represented in terms of its z-transform, this takes the form of a polynomial matrix. We generalise the SVD to broadband adaptive sensor arrays by requiring the strong decorrelation to be implemented using a paraunitary polynomial matrix. A paraunitary polynomial matrix has several important (closely related) properties.

1. It represents a multi-channel all-pass filter.
2. It preserves the total signal energy.
3. It preserves the total energy at every frequency.

In this paper, we describe a novel technique for computing the required paraunitary matrix and show how the resulting broadband SVD algorithm can be applied in practice, e.g., to identify broadband signal and noise subspaces or to separate a multi-channel broadband adaptive filtering problem into a set of independent single-channel problems.

Report Documentation Page

Form Approved
OMB No. 0704-0188

Public reporting burden for the collection of information is estimated to average 1 hour per response, including the time for reviewing instructions, searching existing data sources, gathering and maintaining the data needed, and completing and reviewing the collection of information. Send comments regarding this burden estimate or any other aspect of this collection of information, including suggestions for reducing this burden, to Washington Headquarters Services, Directorate for Information Operations and Reports, 1215 Jefferson Davis Highway, Suite 1204, Arlington VA 22202-4302. Respondents should be aware that notwithstanding any other provision of law, no person shall be subject to a penalty for failing to comply with a collection of information if it does not display a currently valid OMB control number.

1. REPORT DATE 20 DEC 2004	2. REPORT TYPE N/A	3. DATES COVERED -	
4. TITLE AND SUBTITLE A Novel Technique for Broadband Singular Value Decomposition		5a. CONTRACT NUMBER	
		5b. GRANT NUMBER	
		5c. PROGRAM ELEMENT NUMBER	
6. AUTHOR(S)		5d. PROJECT NUMBER	
		5e. TASK NUMBER	
		5f. WORK UNIT NUMBER	
7. PERFORMING ORGANIZATION NAME(S) AND ADDRESS(ES) QinetiQ Ltd		8. PERFORMING ORGANIZATION REPORT NUMBER	
9. SPONSORING/MONITORING AGENCY NAME(S) AND ADDRESS(ES)		10. SPONSOR/MONITOR'S ACRONYM(S)	
		11. SPONSOR/MONITOR'S REPORT NUMBER(S)	
12. DISTRIBUTION/AVAILABILITY STATEMENT Approved for public release, distribution unlimited			
13. SUPPLEMENTARY NOTES See also, ADM001741 Proceedings of the Twelfth Annual Adaptive Sensor Array Processing Workshop, 16-18 March 2004 (ASAP-12, Volume 1), The original document contains color images.			
14. ABSTRACT			
15. SUBJECT TERMS			
16. SECURITY CLASSIFICATION OF:			17. LIMITATION OF ABSTRACT
a. REPORT unclassified	b. ABSTRACT unclassified	c. THIS PAGE unclassified	UU
			18. NUMBER OF PAGES 21
			19a. NAME OF RESPONSIBLE PERSON

A NOVEL TECHNIQUE FOR BROADBAND SVD

*J G McWhirter and P D Baxter.**

QinetiQ Ltd
Malvern, Worcs. WR14 3PS
England
mcwhirter@signal.qinetiq.com

ABSTRACT

A generalisation of the SVD is proposed for broadband sensor array signal processing. A novel technique for computing the broadband SVD is outlined. This involves applying a sequence of elementary paraunitary matrices and is referred to as the second order sequential best rotation algorithm (SBR2). An application of the SBR2 algorithm to broadband subspace identification is briefly illustrated.

1. INTRODUCTION

The singular value decomposition (SVD) is a very important tool for narrowband adaptive sensor array processing. It finds application in areas as diverse as high resolution direction finding, stabilised adaptive beamforming and blind signal separation [1,2]. The SVD decorrelates the signals received from an array of sensors by applying a unitary matrix of complex scalars which serves to modify the signals in phase and amplitude. Because the transformation is unitary, the associated singular values represent the true energy associated with each of the decorrelated components so the signal and noise subspaces may sometimes be identified and separated.

In broadband applications, or a situation where narrowband signals have been convolutively mixed, the received signals cannot be represented in terms of phase and amplitude. Instantaneous decorrelation using a unitary matrix is no longer sufficient to separate them. It is necessary to impose decorrelation, not just at the same time instant for all signals, but over a suitably chosen range of relative time delays. This is referred to as strong decorrelation and achieving it requires a matrix of suitably chosen finite impulse response (FIR) filters. If each filter is represented in terms of its z-transform, this takes the form of a polynomial matrix.

In this paper we generalise the SVD to broadband adaptive sensor arrays by requiring the strong

decorrelation to be implemented using a paraunitary polynomial matrix. A paraunitary polynomial matrix represents a multi-channel all-pass filter and, accordingly, it preserves the total signal energy at every frequency [3]. We also present a novel technique for computing the required paraunitary matrix and show how the resulting broadband SVD algorithm (SBR2) can be used in practice to identify broadband signal and noise subspaces. The algorithm, being highly generic in nature, has potential application to a wide range of important problems. These include broadband adaptive beamforming, broadband blind signal separation [4], multi-channel adaptive noise cancellation, the analysis of multiple-input multiple-output (MIMO) communication channels and the design of filter banks for optimal data compaction.

Our approach is quite distinct from other methods reported to date. One fairly obvious technique is to reduce the broadband problem to narrowband form using a DFT or FFT to split the data into narrower frequency bands. A conventional SVD can then be used to decorrelate the sensor signals within each band. However, the SVD will arrange the uncorrelated output channels in order of decreasing energy. In the context of blind signal separation [4] this means that the original signals are likely to be assigned to a different channel in each frequency bin and so the reconstituted broadband signals may be remixed in an arbitrary manner. Furthermore, they may not be as strongly decorrelated as possible since the individual frequency bins are only statistically independent to an approximation governed by the effect of overlapping sidelobes in their frequency response. This is a well known feature of the independent frequency bin technique for space time adaptive processing in radar detection [5].

Regalia and Huang [6] have addressed the problem of computing an adaptive lossless FIR filter for optimal data compaction. This leads to the determination of an optimum paraunitary matrix as required for our broadband SVD algorithm. Their approach exploits the fixed degree parameterisation proposed by Vaidyanathan [3] resulting

* This research was sponsored by the United Kingdom Ministry of Defence Corporate Research Programme.

in a difficult nonlinear optimisation. However, they reformulate the problem using a state space model and propose an iterative solution which avoids the problems of local minima associated with gradient descent techniques. A comparison with the SBR2 algorithm presented in this paper has still to be carried out.

Lambert [7] has addressed the problem of broadband blind signal separation in the context of convolutive mixing. He represents the convolutive mixing in terms of DFT filter matrices as well as polynomial matrices. He has developed an EVD algorithm for polynomial matrices by generalising some conventional linear algebra and control techniques from the complex number field to the field of rationals. His method involves the approximate inversion of FIR filters and is therefore quite distinct from the one proposed here. A comparison with the SBR2 algorithm is currently being carried out.

This paper is organised as follows. Section 2 briefly describes how the SVD is used in narrowband sensor array signal processing. Section 3 discusses broadband sensor arrays and shows how the convolutive mixing of independent signals may be formulated in terms of polynomial matrices. The concept of a broadband SVD suitable for convolutive mixtures is then introduced. A tractable approach to computing the broadband SVD is described in section 4 and a prototype algorithm is then outlined. Section 5 presents the results of some preliminary numerical simulations using the algorithm to perform broadband subspace decomposition. Section 6 contains some concluding remarks.

2. NARROWBAND SVD

To illustrate the use of SVD in sensor array signal processing, we consider a situation where the narrowband signals $\{s_i(t) \mid i=1,2,\dots,q\}$ emitted from q different sources are received by an array of p sensor elements where $p \geq q$. The output signals $\{x_i(t) \mid i=1,2,\dots,p\}$ may be represented by an "instantaneous mixture" model of the form

$$\mathbf{X} = \mathbf{A}\mathbf{S} + \mathbf{N} \quad (2.1)$$

where \mathbf{S} is a $q \times T$ matrix whose rows constitute the signal vectors \mathbf{s}_i^T each comprising T samples of the corresponding signal $s_i(t)$. \mathbf{X} is a $p \times T$ matrix whose rows constitute the corresponding signal vectors \mathbf{x}_i^T received by elements in the sensor array. \mathbf{A} represents a $p \times q$ matrix of complex values where the general element A_{ij} represents the relative phase and amplitude of the j th signal at the i th sensor. The $p \times T$ matrix \mathbf{N} constitutes random samples of a white noise process with variance σ^2 . It is assumed that the original (unit power)

signals $s_i(t)$ are statistically independent and therefore uncorrelated so that

$$\mathbf{S}\mathbf{S}^H = \mathbf{I}_q. \quad (2.2)$$

Clearly the signals $\mathbf{x}_i(t)$ received at the sensor array will not generally be uncorrelated due to the mixing described in equation (2.1). Indeed, it follows immediately that the correlation matrix, given by

$$\mathbf{X}\mathbf{X}^H = \mathbf{A}\mathbf{A}^H + \sigma^2\mathbf{I}_p, \quad (2.3)$$

will not be diagonal in general circumstances.

Given a data matrix \mathbf{X} whose individual signals \mathbf{x}_i are not uncorrelated, there are several well known techniques for generating a set of uncorrelated signals by linear transformation of the original set. One approach is to perform a singular value decomposition of the data matrix \mathbf{X} i.e. to compute a transformation of the form

$$\mathbf{X} = \mathbf{U}^H \mathbf{D}\mathbf{V} \quad (2.4)$$

where \mathbf{U} is a $p \times p$ unitary matrix, \mathbf{V} is a $p \times T$ matrix whose rows, \mathbf{v}_i^T , are orthonormal and \mathbf{D} is the diagonal matrix $\text{diag}\{d_1, d_2, \dots, d_p\}$ with $d_1 \geq d_2 \dots \geq d_p$.

Since \mathbf{U} is unitary, we may write

$$\mathbf{U}\mathbf{X} = \mathbf{D}\mathbf{V} \quad (2.5)$$

and so it is clear that the rows of $\mathbf{D}\mathbf{V}$ constitute a linear combination of the original signals. Furthermore, since the rows of \mathbf{V} are orthonormal, it can be seen that the rows of $\mathbf{D}\mathbf{V}$ represent uncorrelated signals of magnitude d_i . It is worth noting here, that the unitary matrix \mathbf{U} can also be obtained by performing an eigenvalue decomposition (EVD) on the covariance matrix $\mathbf{X}\mathbf{X}^H$ defined in equation (2.3). It follows immediately from equation (2.4) that

$$\mathbf{X}\mathbf{X}^H = \mathbf{U}^H \mathbf{D}^2 \mathbf{U} \quad (2.6)$$

so the eigenvalues of $\mathbf{X}\mathbf{X}^H$ are d_i^2 and the corresponding eigenvectors are the rows of \mathbf{U} .

Assuming that the signal to noise ratio (SNR) is sufficiently high and the mixing matrix has full column rank, performing an SVD of the data matrix \mathbf{X} in equation (2.1) will produce a diagonal matrix in which $d_i \approx \sigma$ for $i > q$ and $d_i \gg \sigma$ for $i \leq q$. The first q rows of \mathbf{V} define the signal subspace; the other rows define the noise subspace which may thus be identified and separated. A critically important feature of the SVD is that the matrix \mathbf{U} which transforms the matrix of correlated signals \mathbf{X} into the matrix of uncorrelated signals $\mathbf{D}\mathbf{V}$ is unitary. As a

result, the total energy of the original signals is preserved under the transformation i.e.

$$\sum_{i=1}^p \|\mathbf{x}_i\|^2 = \text{trace}\{\mathbf{X}\mathbf{X}^H\} = \text{trace}\{\mathbf{U}^H \mathbf{D}^2 \mathbf{U}\} = \sum_{i=1}^p d_i^2 \quad (2.7)$$

Without this property, the distribution of energy between the signal and noise subspaces would not have any physical significance.

3. BROADBAND SIGNALS AND CONVOLUTIVE MIXING

The purpose of this paper is to suggest a novel technique for extending the SVD to broadband signals and the associated problem of convolutive mixing. For ease of notation in the broadband case, we confine our attention initially to the special case of two signals (assumed to be real) and two sensors. In the case of broadband signals, the relative delays between different propagation paths cannot be represented in terms of phase and amplitude factors imposed at the sensor elements as in equation (2.1). Instead, the mixing must be represented as a linear superposition of delayed samples of the signals emitted by each source. In the case of two signals and two sensors this may be expressed in the form:

$$\begin{aligned} x_1(t) &= a_{11} \otimes s_1(t) + a_{12} \otimes s_2(t) \\ x_2(t) &= a_{21} \otimes s_1(t) + a_{22} \otimes s_2(t) \end{aligned} \quad (3.1)$$

where \otimes denotes the convolution operator i.e.

$$x(t) = a \otimes s(t) = \sum_{k=0}^l a(k)s(t-k) \quad t=0,1,2,\dots \quad (3.2)$$

(and we have assumed that $s(t)=0$ for $t < 0$). Each sensor to signal channel is described by a different FIR filter a_{ij} ($i,j = 1,2$) which models the effect of multipath propagation and dispersion. This is generally referred to as convolutive mixing. In terms of the polynomial representations (z-transforms) given by

$$\begin{aligned} a(z) &= a(0) + a(1)z^{-1} + a(2)z^{-2} + \dots + a(p)z^{-l} \\ s(z) &= s(0) + s(1)z^{-1} + s(2)z^{-2} + s(3)z^{-3} + \dots \quad (3.3) \\ x(z) &= x(0) + x(1)z^{-1} + x(2)z^{-2} + x(3)z^{-3} + \dots \end{aligned}$$

the convolution in equation (3.2) may be expressed as a simple product of the form

$$x(z) = a(z)s(z) \quad (3.4)$$

Similarly equation (3.1) may be written in the form

$$\begin{bmatrix} x_1(z) \\ x_2(z) \end{bmatrix} = \begin{bmatrix} a_{11}(z) & a_{12}(z) \\ a_{21}(z) & a_{22}(z) \end{bmatrix} \begin{bmatrix} s_1(z) \\ s_2(z) \end{bmatrix} \quad (3.5)$$

i.e.

$$\mathbf{x}(z) = \mathbf{A}(z)\mathbf{s}(z) \quad (3.6)$$

where $\mathbf{A}(z)$ is now a polynomial matrix. If the broadband signals $s_1(t)$ and $s_2(t)$ in equation (3.1) are statistically independent, they will also be uncorrelated and so the cross-correlation at all lags must be zero i.e.

$$E[s_1(t)s_2(t-k)] = E[s_2(t)s_1(t-k)] = 0 \quad (k=0,1,\dots) \quad (3.7)$$

Assuming that these expectation values are estimated by unnormalised temporal averages of the form

$$E[s_1(t)s_2(t-k)] = \frac{T}{t=0} \sum s_1(t)s_2(t-k) \quad , \quad (3.8)$$

it is possible to express equation (3.7) in the form

$$s_1(z)s_2(1/z) = s_1(1/z)s_2(z) = 0 \quad (3.9)$$

In terms of polynomial matrices, the correlation at all lags may be expressed in the form

$$\begin{aligned} \mathbf{R}^s(z) &= \mathbf{s}(z)\tilde{\mathbf{s}}(z) = \begin{bmatrix} s_1(z) \\ s_2(z) \end{bmatrix} \begin{bmatrix} s_1(1/z) & s_2(1/z) \end{bmatrix} \\ &= \begin{bmatrix} \sigma_1(z) & 0 \\ 0 & \sigma_2(z) \end{bmatrix} \end{aligned} \quad (3.10)$$

where $\sigma_i(z) = s_i(z)s_i(1/z)$ corresponds to the auto-correlation function or spectrum of the i^{th} signal. Note that the polynomial matrix $\mathbf{R}^s(z)$ is diagonal. The tilde operation is used to represent paraconjugation i.e. the combined operations of matrix transposition, substitution of z^{-1} for z and, more generally, complex conjugation [3]. As a result of the mixing process in equation (3.6), the received signals $x_1(t)$ and $x_2(t)$ will generally be correlated and the polynomial correlation matrix will not be diagonal since

$$\mathbf{R}^x(z) = \mathbf{x}(z)\tilde{\mathbf{x}}(z) = \mathbf{A}(z) \begin{bmatrix} \sigma_1(z) & 0 \\ 0 & \sigma_2(z) \end{bmatrix} \tilde{\mathbf{A}}(z) \quad (3.11)$$

The first stage of many signal processing algorithms is to filter and recombine these signals in order to generate signals $v_1(t)$ and $v_2(t)$ which (to a good approximation) are uncorrelated. This may be achieved by a number of standard techniques such as multi-channel linear prediction using a least squares lattice filter [1]. However, since these methods do not conserve the spectral energy in the signals, they can not be used to identify the signal and noise subspaces. In order to overcome this limitation, it would be highly desirable to have a suitable broadband SVD algorithm.

We propose a broadband SVD algorithm of the form

$$\begin{bmatrix} v_1(z) \\ v_2(z) \end{bmatrix} = \begin{bmatrix} h_{11}(z) & h_{12}(z) \\ h_{21}(z) & h_{22}(z) \end{bmatrix} \begin{bmatrix} x_1(z) \\ x_2(z) \end{bmatrix} \quad (3.12)$$

i.e.

$$\mathbf{v}(z) = \mathbf{H}(z)\mathbf{x}(z) \quad (3.13)$$

where

$$\mathbf{v}(z)\tilde{\mathbf{v}}(z) \equiv \begin{bmatrix} d_1(z) & 0 \\ 0 & d_2(z) \end{bmatrix} \quad (3.14)$$

and $\mathbf{H}(z)$ is constrained to be a paraunitary matrix. This means that

$$\mathbf{H}(z)\tilde{\mathbf{H}}(z) = \tilde{\mathbf{H}}(z)\mathbf{H}(z) = \mathbf{I} \quad (3.15)$$

where the tilde again denotes paraconjugation. The polynomial matrix is constrained to be paraunitary so that the spectral energy of the two signals is conserved as a result of the transformation [3]. This ensures that the energy in the resulting broadband signal and noise subspaces has proper physical significance.

The challenge then, is to compute a paraunitary matrix $\mathbf{H}(z)$ such that the correlation matrix in equation (3.14) is as close to diagonal as possible. In general, it will not be possible to achieve exact diagonalisation since the paraunitary matrix is composed of FIR filters. These cannot be expected to undo the type of correlation induced by an FIR (or rational) mixing matrix. However, if the number of delay stages in the filter elements of the paraunitary matrix is sufficiently large, the decorrelation can be achieved to a very good approximation.

Since a general polynomial matrix is not necessarily paraunitary, it is vital to ensure that the approximate diagonalisation is carried out over the restricted subspace of paraunitary matrices. The easiest way of generating a paraunitary matrix is to use a suitably parameterised representation - one which is guaranteed to be paraunitary irrespective of the parameter values. Vaidyanathan [3] has shown that (apart from a possible channel swap) an arbitrary FIR paraunitary matrix can be decomposed into a set of rotations interspersed by delays. In the two channel case, a paraunitary matrix $\mathbf{H}_N(z)$ of degree¹ N is decomposed as

$$\mathbf{H}_N(z) = \mathbf{Q}_N \dots \mathbf{\Lambda}(z) \mathbf{Q}_1 \mathbf{\Lambda}(z) \mathbf{Q}_0 \quad (3.16)$$

where $\mathbf{\Lambda}(z)$ denotes a unit delay applied to one channel i.e.

$$\mathbf{\Lambda}(z) = \begin{bmatrix} 1 & 0 \\ 0 & z^{-1} \end{bmatrix} \quad (3.17)$$

¹ The degree of a paraunitary matrix is defined as the number of delays needed to implement it. This is not the same as the order which is the highest power of z^{-1} in the polynomial matrix.

and \mathbf{Q}_i represents a simple 2×2 unitary matrix which can be parameterised by a single rotation angle. For the purposes of broadband SVD, the challenge is to identify rotation matrices $\mathbf{Q}_0, \dots, \mathbf{Q}_N$ which minimise the output cross-correlation over multiple time lags. Attempting to optimise the parameters of such a filter is still quite difficult since the individual rotations cannot be computed independently and a multi-parameter nonlinear optimisation is required. It is worth noting that in the limiting case of a single stage this takes the form of a single rotation matrix and so the problem reduces to that of conventional narrowband SVD.

4. SEQUENTIAL BEST ROTATION ALGORITHM

In order to simplify the problem we adopt a different formula for generating the paraunitary matrices. This takes the form

$$\mathbf{H}(z) = \mathbf{Q}_L \mathbf{\Lambda}^{d_L} \dots \mathbf{Q}_1 \mathbf{\Lambda}^{d_1} \quad (4.1)$$

where the integer parameters d_i can be negative or positive. It can be seen that any polynomial matrix generated by (4.1) is paraunitary since each stage is paraunitary. However the degree is no longer certain. Equation (4.1) introduces the important new concept of an “elementary paraunitary matrix” $\mathbf{V}_i(z) = \mathbf{Q}_i \mathbf{\Lambda}^{d_i}$ which comprises a number (possibly negative) of delays applied to one channel followed by a rotation [4]. It is elementary in the sense that it only involves one rotation, but it does not necessarily have degree one. The second order sequential best rotation algorithm (SBR2) seeks to generate a paraunitary matrix of this type by calculating and applying a sequence of elementary paraunitary matrices as illustrated in figure 1. This sequence is designed to minimise the strong decorrelation measure

$$N_3^{\max} = \sum_{\tau=0}^{T-1} \{r_{12}(\tau)^2 + r_{21}(\tau)^2\} \quad (4.2)$$

where $r_{ij}(\tau)$ ($i, j = 1, 2$) denotes the estimated correlation between signals i and j at lag τ given by

$$r_{ij}(\tau) = \sum_{t=1}^T x_i(t)x_j(t-\tau) \quad (4.3)$$

To simplify the analysis, and avoid the problem of an effective window length which depends on the lag τ , we make the assumption that the block of data repeats cyclically so that $x_i(t) = x_i(t \pm T)$. Provided the block length T is sufficiently large, this should be just as good an approximation as the use, for example, of zero padding.

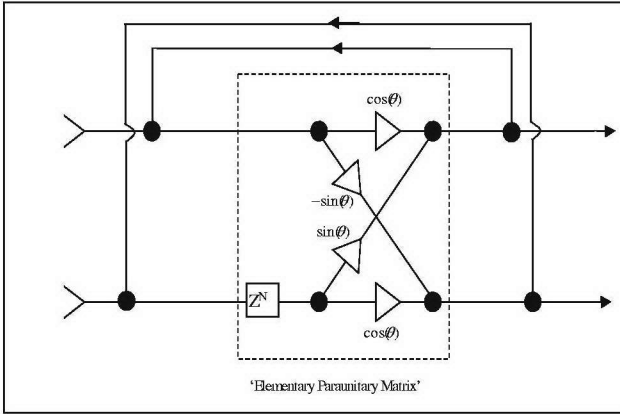

Figure 1. Diagrammatic representation of SBR2 algorithm

Each step of the algorithm applies a single elementary paraunitary matrix, chosen to maximise an instantaneous measure of decorrelation evaluated at that stage (equation 4.4). This might not appear to be a sensible strategy since the successive elementary paraunitary matrices do not commute and applying a rotation doesn't just affect the current state but also the potential future gains of the algorithm. Unlike the narrowband case, applying a poorly chosen rotation is likely to make the problem more difficult by increasing the order of the mixing polynomial for no good reason. However, the freedom to choose an optimum delay for each stage makes the process in figure 1 much more meaningful.

In order to explain the operation of the algorithm we introduce the following set of measures relating to the instantaneous correlation of two signals $x_1(t)$ and $x_2(t)$:

$$N_1 = r_{11}(0)^2 + r_{22}(0)^2 \quad (4.4)$$

$$N_2 = \sum_{i,j=1}^2 r_{ij}(0)^2 \quad (4.5)$$

and

$$N_3 = N_2 - N_1 = 2r_{12}(0)^2 \quad (4.6)$$

N_3 constitutes an instantaneous measure of cross-correlation between the two signals while N_2 is simply the norm of the instantaneous correlation matrix. It is easy to show that N_2 is invariant to a rotation of the two signal channels and obvious that N_1 is invariant to a delay applied to either channel. As N_2 is invariant and constitutes the sum of N_1 and N_3 , any rotation which leads to a reduction in the value of N_3 must increase N_1 by the same amount. Since N_1 is unaffected by subsequently delaying either channel, it follows that successive steps of the SBR2 algorithm must lead to a strict increase in the value of N_1 overall.

At each stage of the algorithm, the delay is chosen to achieve the maximum possible increase in the value of N_1 . Now for any pair of signals, the value of N_3 can be driven to zero by rotating them through an angle θ given by

$$\tan(2\theta) = \frac{2r_{12}(0)}{r_{11}(0) - r_{22}(0)} \quad (4.7)$$

so it follows that the best delay is the one for which N_3 is greatest prior to the rotation i.e. the one which maximises the instantaneous correlation between the shifted signals. It has been shown [8] that this sequence of operations must converge to a solution which achieves strong decorrelation in the sense that $N_3^{\max} \rightarrow 0$ but the proof is not included here due to limitations on space. The SBR2 algorithm for two signals may be summarised as follows:

- 1) Apply a relative delay between the two signals so that the instantaneous correlation between them is maximised.
- 2) Rotate the signals through an angle θ which drives the instantaneous correlation to zero.
- 3) Repeat steps 1 and 2 until the value of N_1 achieves its maximum value to within a specified tolerance.

In this paper we have chosen to describe the SBR2 algorithm in terms of elementary paraunitary matrices applied directly to the received signals (data domain). However, just as the conventional SVD algorithm can also be computed in terms of similarity transformations applied to the associated covariance matrix, so the SBR2 algorithm can be formulated in terms of elementary paraunitary matrices and their paraconjugates applied from the left and right respectively to the pre-computed broadband correlation matrix defined in equation (3.11). This formulation (covariance domain) may not be quite so good from a numerical perspective, but it leads to a more efficient computation and has the advantage that the broadband correlation can be windowed in time to reduce the effect of sample noise if appropriate. It follows that the SBR2 algorithm may be viewed more fundamentally as a paraunitary technique for diagonalising any para-symmetric polynomial matrix.

Vaidyanathan [9] has shown that in certain circumstances the paraunitary matrix required to achieve strong decorrelation may not be uniquely defined without imposing spectral majorisation on the output signals. It is worth pointing out that, by virtue of the cost function used, the SBR2 algorithm tends to impose spectral majorisation on the output signals provided this is consistent with the requirement for strong decorrelation, bearing in mind that individual frequency components are not necessarily independent.

In this short paper we have only presented the SBR2 algorithm for the relatively simple case of two signal

channels. This is sufficient to explain the key features of our approach. However, the method may be generalised to multiple channels in several ways. We have developed two specific multi-channel versions. One of these may be viewed as a generalisation of the classical Jacobi algorithm for matrix diagonalisation. The other may be viewed as a generalisation of the standard cyclic-by-rows Jacobi algorithm. The results presented in the next section were produced using the former option.

5. RESULTS

In order to demonstrate briefly that the SBR2 algorithm works in practice, we present the results of a preliminary numerical experiment. The propagation of 3 signals onto 5 sensors was modelled by means of a 5×3 polynomial mixing matrix whose entries were 5th order FIR filters with coefficients drawn randomly from a uniform distribution in the range $[-1, 1]$. The source signals took the form of independent BPSK sequences where each sample takes the value ± 1 with probability $1/2$. Gaussian random noise was added to each simulated sensor output with variance chosen to achieve the desired SNR. Blocks of 1000 data samples were used for each simulation.

The SBR2 algorithm was used to strongly decorrelate the signals and diagonalise the broadband covariance matrix as indicated in equation (3.14). The signal and noise subspaces were then identified and separated based on the energy of the decorrelated output channels. The signal subspace was defined by three strongest channels. The integrity of the signal and noise subspaces was quantified using a measure of the form $\alpha = \alpha_n / \alpha_s$ where α_n denotes the projection of the original signals onto the computed noise subspace and α_s represents the projection of the original signals onto the computed signal subspace. The smaller the value of α the more reliable the subspace estimation.

The value of α as a function of SNR is plotted in figure 2. Each point on the graph represents the value of α averaged over 100 independent realisations of the experiment. It can be seen that $\alpha < 0.2$ for values of SNR down to -10dB indicating that the algorithm is capable of effective broadband subspace decomposition. Numerous other successful computer simulations have been carried out and will be reported in a future publication.

6. CONCLUSIONS

In this paper we have introduced the concept of a broadband SVD and suggested a tractable approach to performing the necessary computation. A prototype algorithm has been outlined and some initial results presented. In many respects, the method presented here may be viewed as a direct extension of the Jacobi algorithm for conventional eigenvalue or singular value

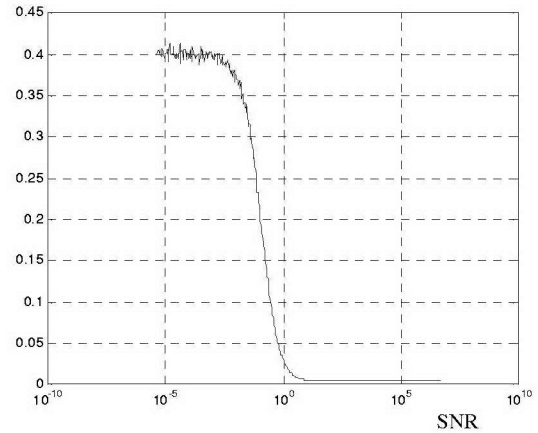

Figure 2. Broadband subspace decomposition. Plot of the α measure vs SNR

decomposition. A proof of convergence has been obtained. Numerous variations and refinements are possible. Several of these have been investigated but they can not be reported in this short paper. Together with others which remain to be explored, they will be presented in a future publication. #

7. REFERENCES

- [1] S Haykin, "Adaptive Filter Theory", 3rd edition, Prentice Hall (1996).
- [2] P Comon, "Independent component analysis, A new concept?", Signal Processing, vol 36, pp 287-314 (1994)
- [3] P P Vaidyanathan, "Multirate Systems and Filterbanks", Prentice Hall (1993).
- [4] P D Baxter and J G McWhirter, "Blind signal separation of convolutive mixtures", Proc 37th Asilomar Conference on Circuits, Systems and Computers (Nov 2003).
- [5] R Klemm, "Space-Time Adaptive Processing Principles and Applications", IEE Radar, Sonar, Navigation and Avionics Series 9 (1998).
- [6] P A Regalia and D-Y Huang, "Attainable error bounds in multirate adaptive lossless FIR filters", Proc IEEE Conf. ICASSP (1995) pp.1460-63.
- [7] R Lambert, "Multichannel blind deconvolution: FIR matrix algebra and separation of multipath mixtures", PhD Thesis, USC (1996).
- [8] T Cooper, QinetiQ Ltd, private correspondence (2003).
- [9] P P Vaidyanathan, "Theory of optimal orthonormal subband coders", IEEE Trans Signal Processing, Vol 46, No 6, pp 1528-43 (June 1998)

The authors are extremely grateful to Tom Cooper and Soydan Redif of QinetiQ Ltd for the proof of convergence and the numerical simulations respectively.

A Novel Technique for Broadband SVD

J G McWhirter and P D Baxter
QinetiQ Ltd, Malvern

The logo for QinetiQ, featuring the company name in white text on a blue, curved background element.

QinetiQ

Outline of Talk

- Context and motivation
- Polynomial matrix formulation
- Definition of broadband SVD
- Elementary paraunitary transformations
- Sequential best rotation algorithm (SBR2)
- Preliminary results

Blind Signal Separation (instantaneous)

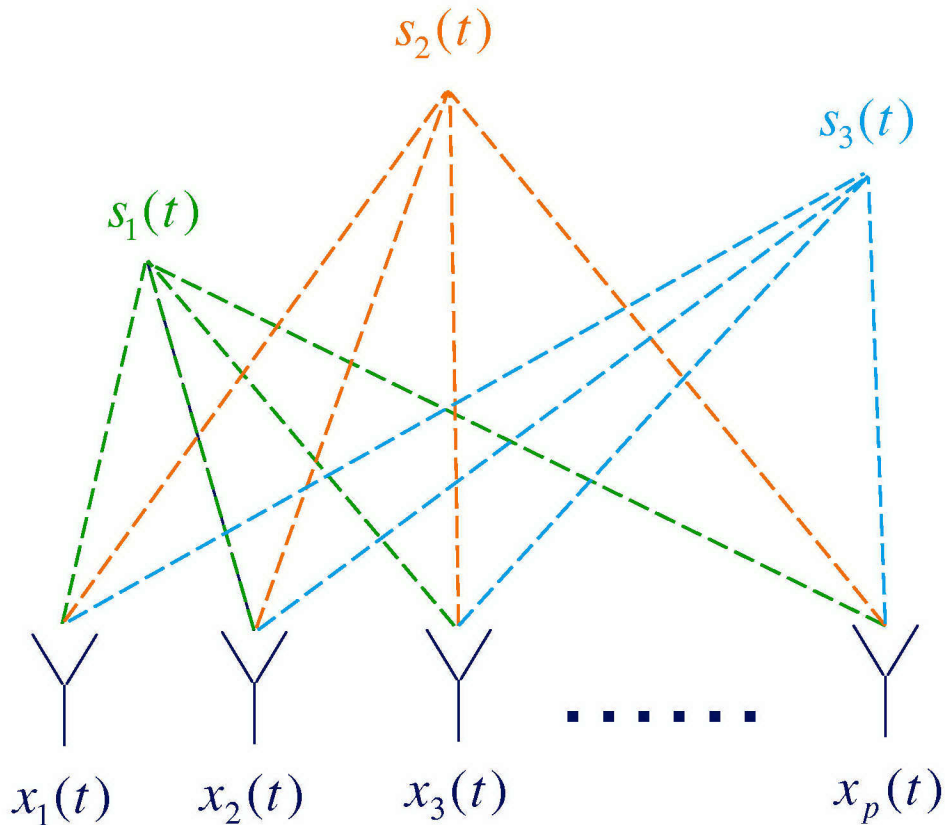

- Signal model
$$\mathbf{x}(t) = \mathbf{A}\mathbf{s}(t) + \mathbf{n}(t)$$
- Data matrix
$$\mathbf{X} = \mathbf{A}\mathbf{S} + \mathbf{N}$$
- Unknown mixture matrix \mathbf{A}
- Unknown signals \mathbf{S}
 - statistically independent
 - therefore uncorrelated

Principal Components Analysis (PCA)

- Signal model $\mathbf{X} = \mathbf{A}\mathbf{S} + \mathbf{N}$
- Singular value decomposition (SVD)

$$\begin{aligned}\mathbf{X} &= \mathbf{U}\mathbf{D}\mathbf{V} \\ &= [\mathbf{U}_s \quad \mathbf{U}_n] \begin{bmatrix} \mathbf{D}_s & \mathbf{0} \\ \mathbf{0} & \sigma\mathbf{I} \end{bmatrix} \begin{bmatrix} \mathbf{V}_s \\ \mathbf{V}_n \end{bmatrix} \\ &= \mathbf{U}_s \mathbf{D}_s \mathbf{V}_s + \sigma \mathbf{U}_n \mathbf{V}_n\end{aligned}$$

- Signal subspace $\mathbf{V}_s = \mathbf{D}_s^{-1} \mathbf{U}_s^H \mathbf{X}$
 $\mathbf{V}_s \mathbf{V}_s^H = \mathbf{I}_s$

$$\sum_{t=1}^T v_i(t)v_j(t) = \delta_{ij}$$

Convolutive Mixing

- Effects of dispersion, multipath etc
 - Typical of urban environment
 - Cocktail party effect

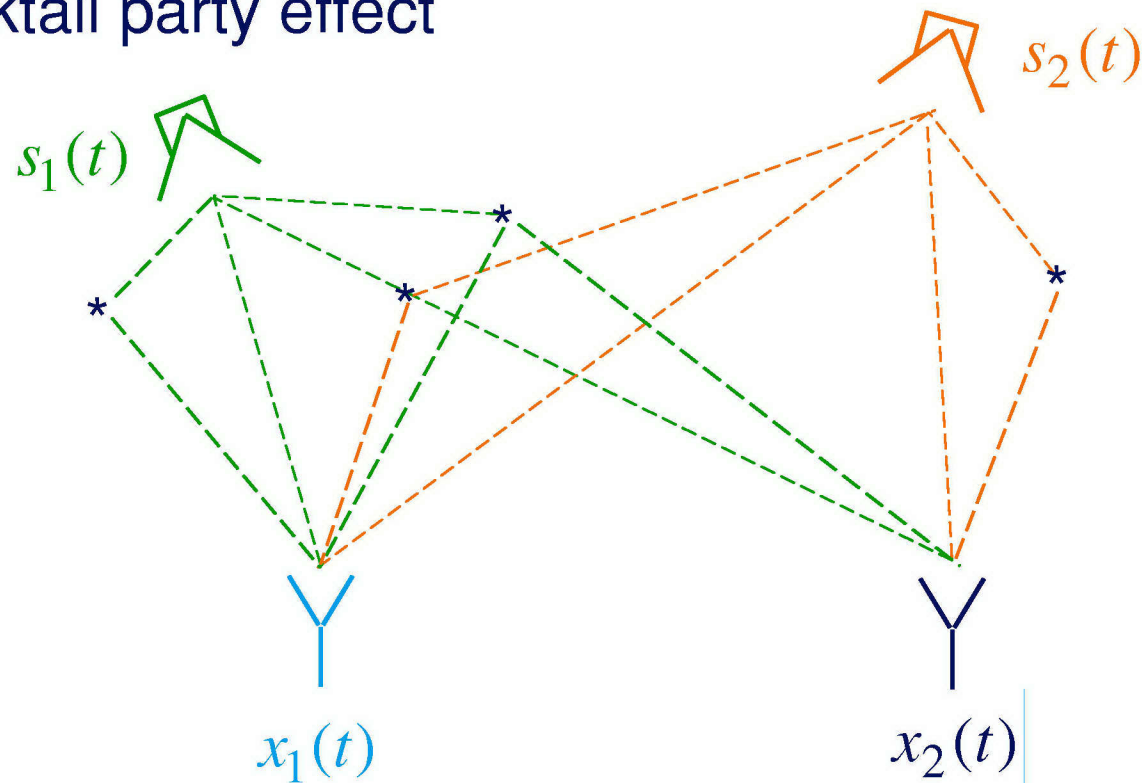

Channel Model

- Weighted sum of delayed samples (convolution)

$$x(n) = h_0s(n) + h_1s(n-1) + \dots\dots\dots h_p s(n-p)$$

- Express in *polynomial* form (z-transform)

$$h(z) = h_0 + h_1z^{-1} + \dots\dots\dots h_p z^{-p}$$

$$s(z) = s(0) + s(1)z^{-1} + \dots\dots\dots s(n)z^{-n} + \dots\dots\dots$$

$$x(z) = x(0) + x(1)z^{-1} + \dots\dots\dots x(n)z^{-n} + \dots\dots\dots$$

- Convolution becomes *simple product*

$$x(z) = h(z)s(z)$$

Convolutive Mixing

- Two signals and two sensors

$$\begin{aligned}x_1(z) &= a_{11}(z)s_1(z) + a_{12}(z)s_2(z) \\x_2(z) &= a_{21}(z)s_1(z) + a_{22}(z)s_2(z)\end{aligned}$$

- Polynomial matrix form

$$\begin{bmatrix} x_1(z) \\ x_2(z) \end{bmatrix} = \begin{bmatrix} a_{11}(z) & a_{12}(z) \\ a_{21}(z) & a_{22}(z) \end{bmatrix} \begin{bmatrix} s_1(z) \\ s_2(z) \end{bmatrix}$$

- i.e

$$\mathbf{x}(z) = \mathbf{A}(z)\mathbf{s}(z)$$

Broadband SVD

- Paraconjugation $\tilde{H}(z) = H^T(1/z)$

- Paraunitary matrix

$$H(z)\tilde{H}(z) = \tilde{H}(z)H(z) = I$$

- Paraunitary transformation

$$v(z) = H(z)x(z)$$

s.t.
$$\sum_{t=1}^T v_i(t)v_j(t-\tau) = d_i(\tau)\delta_{ij}$$

i.e
$$v(z)\tilde{v}(z) = \begin{bmatrix} d_1(z) & 0 \\ 0 & d_2(z) \end{bmatrix}$$

Vaidyanathans Parameterisation

- Decomposes any paraunitary matrix of fixed degree into a series of rotation interspersed with delays

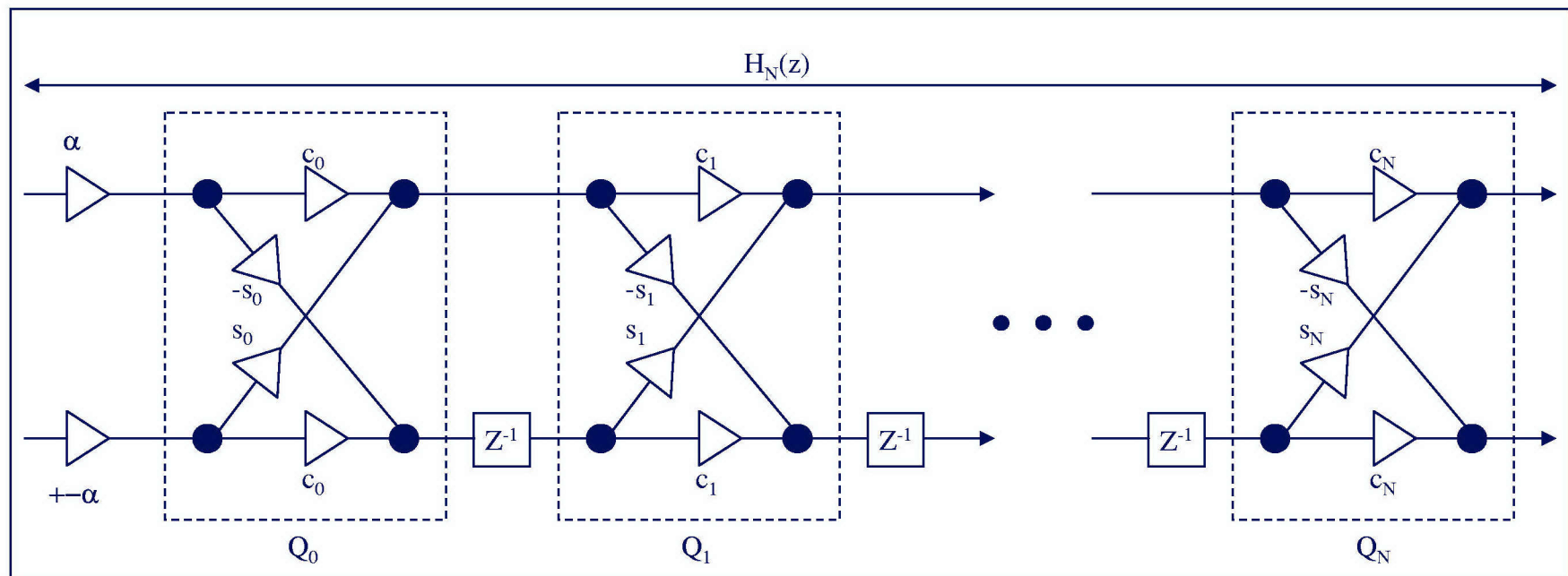

Sequential Best Rotation Algorithm (SBR2)

- Elementary Paraunitary Matrices specified by (N, θ)
- Repeated application of instantaneous decorrelation

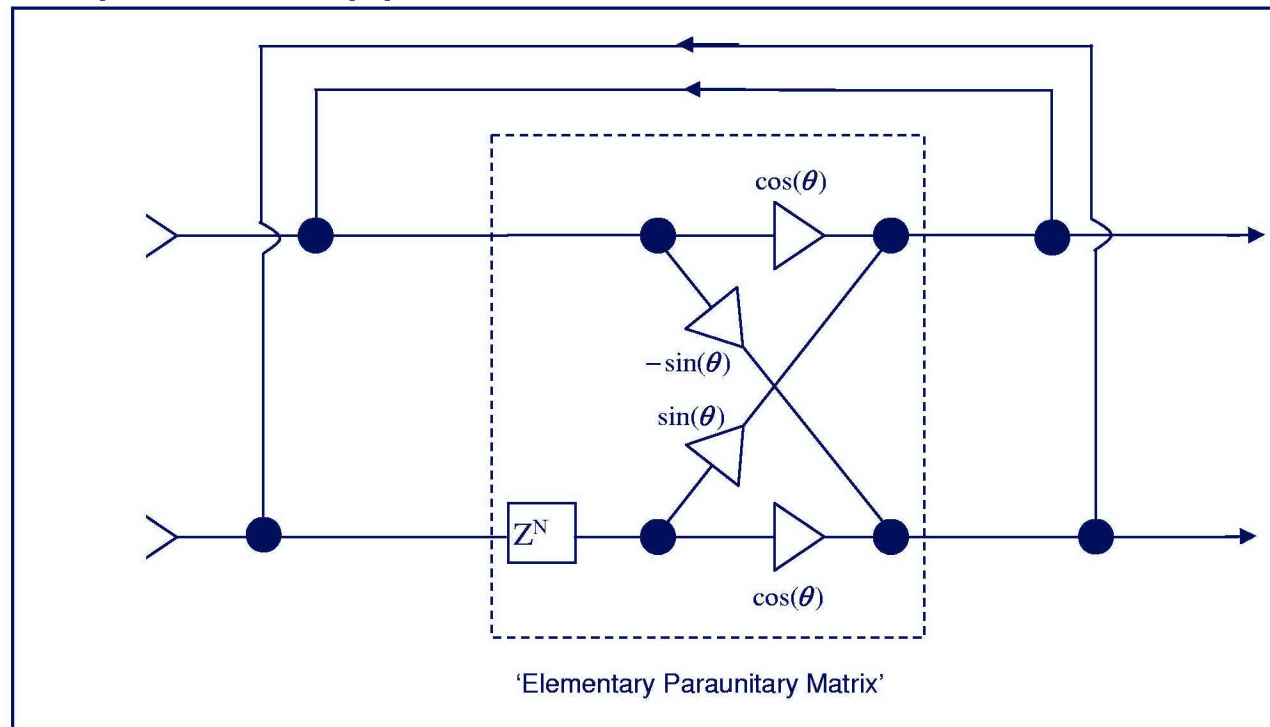

Cost Function for SBR2

- Correlation function

$$r_{ij}(\tau) = \sum_{t=1}^T x_i(t)x_j(t-\tau)$$

- Local (weak) measures

$$N_1 = r_{11}(0)^2 + r_{22}(0)^2$$

$$N_2 = \sum_{i=1}^2 \sum_{j=1}^2 r_{ij}(0)^2$$

$$N_3 = N_2 - N_1 = 2r_{12}(0)^2$$

Cost Function for SBR2

- Instantaneous decorrelation ($N_3 = 0$)

$$\tan(2\theta) = \frac{2r_{12}(0)}{r_{11}(0) - r_{22}(0)}$$

- Strong decorrelation measure

$$N_3^{\max} = \sum_{\tau=0}^{T-1} \{r_{12}(\tau)^2 + r_{21}(\tau)^2\}$$

- Proven convergence

$$N_3^{\max} \rightarrow 0$$

SBR2 Algorithm

- Sequential best rotation algorithm (2nd order)
 - implements strong decorrelation
 - sequence of elementary paraunitary rotations
 - extension to multiple signal case
 - broadband generalisation of Jacobi algorithm for EVD
 - natural tendency towards spectral majorisation
- Broadband SVD technique
 - preserves temporal structure in data
 - more efficient than unstructured SVD
 - generic signal processing tool

Acknowledgements

- This research was sponsored by the United Kingdom Ministry of Defence, Corporate Research Programme

© Copyright QinetiQ Ltd 2004

The logo for QinetiQ, featuring the company name in white text on a blue background that is shaped like a curved banner or wave.

QinetiQ