

AD _____

Award Number: DAMD17-03-2-0001

TITLE: Advanced Video Technology for Safe and Efficient Surgical
Operating Rooms

PRINCIPAL INVESTIGATOR: Doctor Adrian Park

CONTRACTING ORGANIZATION: University of Maryland Medical System
Baltimore, Maryland 21201

REPORT DATE: March 2005

TYPE OF REPORT: Annual

PREPARED FOR: U.S. Army Medical Research and Materiel Command
Fort Detrick, Maryland 21702-5012

DISTRIBUTION STATEMENT: Approved for Public Release;
Distribution Unlimited

The views, opinions and/or findings contained in this report are those of the author(s) and should not be construed as an official Department of the Army position, policy or decision unless so designated by other documentation.

REPORT DOCUMENTATION PAGE

Form Approved
OMB No. 074-0188

Reporting burden for this collection of information is estimated to average 1 hour per response, including the time for reviewing instructions, searching existing data sources, gathering and maintaining the data needed, and completing and reviewing this collection of information. Send comments regarding this burden estimate or any other aspect of this collection of information, including suggestions for reducing this burden to Washington Headquarters Services, Directorate for Information Operations and Reports, 1215 Jefferson Davis Highway, Suite 1204, Arlington, VA 22202-4302, and to the Office of Management and Budget, Paperwork Reduction Project (0704-0188), Washington, DC 20503

1. AGENCY USE ONLY (Leave blank)		2. REPORT DATE March 2005	3. REPORT TYPE AND DATES COVERED Annual (1 Nov 02 - 28 Feb 05)	
4. TITLE AND SUBTITLE Advanced Video Technology for Safe and Efficient Surgical Operating Rooms			5. FUNDING NUMBERS DAMD17-03-2-0001 March 2005	
6. AUTHOR(S) Doctor Adrian Park				
7. PERFORMING ORGANIZATION NAME(S) AND ADDRESS(ES) University of Maryland Medical System Baltimore, Maryland 21201 E-Mail: spark@smail.umaryland.edu			8. PERFORMING ORGANIZATION REPORT NUMBER	
9. SPONSORING / MONITORING AGENCY NAME(S) AND ADDRESS(ES) U.S. Army Medical Research and Materiel Command Fort Detrick, Maryland 21702-5012			10. SPONSORING / MONITORING AGENCY REPORT NUMBER	
11. SUPPLEMENTARY NOTES Original contains color plates. All DTIC reproductions will be in black and white.				
12a. DISTRIBUTION / AVAILABILITY STATEMENT Approved for Public Release; Distribution Unlimited			12b. DISTRIBUTION CODE	
13. ABSTRACT (Maximum 200 Words) No abstract provided.				
14. SUBJECT TERMS No subject terms provided.			15. NUMBER OF PAGES 71	
			16. PRICE CODE	
17. SECURITY CLASSIFICATION OF REPORT Unclassified	18. SECURITY CLASSIFICATION OF THIS PAGE Unclassified	19. SECURITY CLASSIFICATION OF ABSTRACT Unclassified	20. LIMITATION OF ABSTRACT Unlimited	

Table of Contents

Cover.....	1
SF 298.....	2
Table of Contents.....	3
Introduction.....	4
Body.....	5
Key Research Accomplishments.....	9
Reportable Outcomes.....	11
Conclusions.....	
References.....	
Appendices.....	13

Introduction

The Cooperative Agreement Award No. DAMD 17-03-2-001 - Advanced Video Technology for Safe and Efficient Surgical Operating Rooms – identified three specific research objectives:

Research Objective 1: Establish an Operating Room of the Future Test Bed with video-assisted coordination tools.

Working with clinical and technical staff and consultants, a vision was developed for a video infrastructure. This vision was then translated into performance specifications that were then used to identify and select the hardware and software necessary to support this infrastructure. Implementation was completed in conjunction with the construction of new Operating Room suites at the University of Maryland Medical Center. This infrastructure is now operational and has proven valuable as a coordination tool to improve patient safety by improving situational awareness for the OR staff.

Research Objective 2: Test the feasibility of the use of a video enhanced white board.

As a result of this research, a video-based coordination system, named VideoBoard was developed and deployed in the Operating Room of the Future Test Bed. In addition to creating situational awareness for the clinical staff, the system addresses the issue of patient confidentiality and the need for limiting access to patient specific information.

Research Objective 3: Assess the feasibility of creating a new medical education knowledge structure appropriate for distributed learning in the Operating Room of the Future and using that knowledge structure as part of a training curriculum focused upon safety and efficiency in the OR.

A knowledge structure has been conceptualized that will support the development and distribution of learning technologies appropriate for the perioperative environment.

Section E – Body of Final Report

The operating room and perioperative process is the core of intense care provided for many patients. The operating room forms the nucleus of mobile military hospitals. Whether found in civilian or military healthcare, the operating room is a high-cost and high-risk care environment. Many types of cases, multiple surgical specialties, growing use of technology, and the sheer number of elements makes the operating room the most difficult environment to manage in healthcare. This project will provide analysis and data on the novel use of communications technologies, in particular use of video based information for achieving and maintaining situational awareness in high velocity operating rooms. This novel use of video coincides with the DoD Telemedicine Science and Technology Plan in the operational capability areas of 1) Joint Medical Readiness; 2) Battlespace Medical Awareness; and 3) Effective Employment of Medical Forces. The common operational challenges for both civilian and military healthcare in the future addressed by this work include overcoming geographical distances, continual training requirements for medical forces, and high volume, chaotic communications environments in the field and fixed site medical facilities.

The University of Maryland Medical System in conjunction with the University of Maryland School of Medicine and others, proposed to investigate three research objectives related to these issues.

Research Objective 1: Establish an Operating Room of the Future test bed with video-assisted coordination tools.

Working with clinical staff and selected consultants, the University of Maryland Medical System began the conceptualization and implementation of the Operating Room of the Future technology infrastructure to support state-of-the-art video based coordination tools with distributed and flexible access to coordination information and video for learning. This included a requirements analysis of sources and uses of video in the OR and related work spaces, a conceptual functional design and a technical feasibility evaluation. The final schematic design developed as a result of these efforts is attached as Appendix 1-A.

With this as the basis for the performance specifications, a Request for Proposal was released; bids were received from Stryker Communications and PPI. Based on the analysis of these bids from both a technical and financial perspective, Stryker was selected to implement the infrastructure, as summarized in Appendix 1-B.

The installation and testing of the hardware and software has been completed and is currently being used by clinical staff daily. Appendix 1-C includes 4 schematic diagrams of the room layout from various perspectives. Appendix 1-D shows a number of photographs of the rooms.

The driving force for this research objective was to unify the disparate technologies of the Operating Room into one coherent framework and to provide ready access to these disparate sources to the surgeons and other clinical staff in the OR and beyond. Within each OR, there is one technological focal point which ties together laparoscopic images, radiographic images,

surgical navigation, video conferencing, hospital data network, video, and voice. The OR staff then can manipulate the data received and transmit to various viewpoints (flat panel monitors) in the room via touch-panels to provide the necessary information to the correct person, at the correct time, in the correct location. The surgeon, and supportive clinical staff, have hands-free access to the necessary data directly at the surgical field, with the flexibility to change views, sources, or other input devices as needed.

Each room is then tied back to a central HUB, where management at a macro level of the multiple OR's can take place, as well as connection to remote classrooms on campus, or teaching sites across the globe through the use of video conferencing technology.

Research Objective 2: Test the feasibility of the use of a video enhanced white board.

Current delays in OR case starts to frustrate clinicians, patients and families. Improved situational awareness by remote video access to the OR may improve team performance by minimizing lost time. The OR team is a significant cost center for any medical institution. Efficient use of the resources and OR team members is imperative. OR Clinical personnel are among the busiest in a hospital, with time critical procedures to be performed. Provision of audio visual access to the operating room without the need for changing into scrubs and observing infection control precautions will allow novel utilization of video in the OR of the future. Based on this requirement, UMMS proposed to evaluate communications technologies, including video based communications, in conjunction with discrete data, that would be most supportive in managing situational chaos and to determine the strengths and limitations of a hybrid grease board for situational awareness, OR team coordination and improving OR patient throughput.

A team from the National Study Center for Trauma worked with the UMMS clinical staff to perform a requirements analysis. This analysis was then used to develop a conceptual and functional design and test the technical feasibility of that design. The result is a video grease board which display information which improves the situational awareness of the perioperative staff while insuring appropriate security for PPI.

This board display video images of each of the ORs; the image can be displayed in one of three levels of resolutions:

- The original video image captured in the OR
- A corresponding pixilated image which reduces the resolution to recognizable, yet "blocky" image. Objects are recognizable, but individuals are not
- A cartoon abstraction image which allow viewers to determine only if there is movement in the room.

This portion of the board is described in the article titled "Distributed Planning and Monitoring in a Dynamic Environment: Trade-Offs of Information Access and Privacy". This is attached as Appendix 2-A.

In addition to the video image, an algorithm was developed for processing networked vital signs to identify in real-time when a patient enters and leaves a given OR. An icon is added to the grease board to identify if a patient is being monitored. This algorithm is detailed in the article titled "Algorithm for Processing Vital Sign Monitoring Data to Remotely Identify Operating Room Occupancy in Real-Time". This article is attached as Appendix 2-B.

Two additional articles related to this research are attached in the Appendix: Appendix 2-C: "Distributed Monitoring and a Video-Based Toolset" and Appendix 2-D: "Making Management Decisions on the Day of Surgery Based on Operating Room Efficiency and Patient Waiting Times".

Research Objective 3: Assess the feasibility of creating a new medical education knowledge structure appropriate for distributed learning in the Operating Room of the Future and using that knowledge structure as part of a training curriculum focused upon safety and efficiency in the OR.

The goal of this objective is to create a system where a user can interact with a virtual human model in simulation and have the virtual human respond appropriately to user queries and interventions in clinical situations of health and disease. This interaction would allow a user to practice patient management by interpreting virtual patient data, taking actions based upon that interpretation, and then observing the consequences of those actions. This sequence of events has been described by Gott and Lesgold and is a common sequence for problem solving. Repetitive use of this sequence would allow the user to employ trial and error techniques to exercise cognitive skills and would result in the uncovering of knowledge deficits, presumably resulting in re-mediation by the user and subsequent improvement in level of expertise. In this setting, the virtual patient is functioning as the teacher, providing feedback about user performance as judged by patient outcome. In this role, the virtual patient can be referred to as "heuristic" or intrinsically possessing educational value, as described in a recent publication by our group (Mallott, et al.). Such a heuristic patient would be a requisite first step toward an even richer educational simulation, where a user can receive additional forms of feedback from a mentor, including both cognitive and metacognitive teaching, which would include higher intellectual functions such as strategies for effective problem-solving, interpretation of complex information, and so forth. A learning environment containing that level of sophistication would allow advanced learners to be both challenged in a practice environment as well as evaluated for their competence in cognitive decision-making. Further, by allowing for training of health professionals without the need of a "live" patient, patient safety is promoted.

The following goals for the first year of this project:

- Encode medical knowledge consisting of ontological concepts, properties (i.e., attributes and relations), and scripts reflecting the current state of medical knowledge of normal and abnormal structure and function for one organ necessary to drive a cognitive medical education simulation

- Create a disease process possessing structure and function abnormalities and create an instance of a one-organ virtual patient with this disease.
- Create software designed to allow user interactions with and resultant modifications of an instance of the one-organ model. The software has the following functions:
 - can automatically demonstrate clinically relevant function (physiological parameters and responses to user actions) indicative of the current state of the virtual human in response to user queries
 - can automatically change the its state in response to user interventions and temporal events
- Demonstrate that an instance of the virtual abnormal human will perform in a clinically relevant fashion during simulation using the software developed above

Key Research Accomplishments

The key accomplishments of research initiative 1 are:

- Requirements Analysis including sources and uses of video in the operating room and related work spaces
- Development of Conceptual Functional Design
- Completion of Technical Feasibility Evaluation
- Hardware Selection and Implementation
- Functional demonstration of network architecture and related equipment

The key accomplishments of research initiative 2 are:

- Requirements Analysis focused on information valuable to the surgical team in managing situational chaos
- Development of Conceptual Functional Design
- Development of algorithm for processing vital sign monitoring
- Deployment of prototype of video grease board with vital sign monitoring

The key accomplishments of research initiative 3 are:

- We have successfully encoded adequate medical knowledge that includes the following normal concepts
 1. Anatomical structures: a segmented esophagus, with anatomical concepts and terms extracted from the Foundational Model of Anatomy and specified for our use, including elements of the upper and lower esophageal sphincters (UES, LES), muscular components, sensory (pain, pH, temperature, stretch) and motor neuron components (voluntary and autonomic),
 2. Physiological processes: the functional relationships between the muscular components, neural components, and their junctions; the relationships between luminal conditions (such as pH), the food bolus and the stimulation of sensory nerve components; the relationship between sensory nerves and events such as perception of pain or perception of food bolus motion; the relationship between the LES and movement of acid from the stomach to the esophagus
 3. Motion events: the coordination between voluntary initiation of swallowing and the automatic initiation of peristalsis, the interplay of the physiological processes to create this motion, and the effect of esophageal luminal size in each segment on motion of a food bolus as well as whether the bolus moves or not
- We have also encoded knowledge for two abnormal processes
 1. Esophageal tumor—a tumor may be allowed to grow within the esophageal lumen using a simplified growth dynamics for the tumor
 2. Gastro-esophageal reflux—the mechanisms that govern whether reflux occurs and whether it causes symptoms
 - the biological effect of various drugs and foods on the LES tone
 - the effect of the pressure gradient between the LES and the stomach in producing flow of gastric contents into the distal esophagus
 - the effect of various drugs on the pH of the gastric contents

- the effect of different pH liquids in stimulating pH sensory nerves in the distal esophagus
- We have successfully designed processing software using the LISP system to apply Artificial Intelligence concepts to create swallowing function in the esophagus. The software applies concepts from the ontology to an instance of a virtual human and demonstrates normal propulsion of a food bolus from the oropharynx to the stomach. It allows a tumor to be created and enlarged by allowing a user to change the tumor size parameter. As the tumor is enlarged, swallowing of solids stops when $\frac{1}{2}$ of the lumen is obstructed and swallowing of liquids stops at 90% occlusion. If the obstruction is relieved, swallowing resumes. The output from this software demonstrates the location of the bolus over time during swallowing.

Reportable Outcomes

Publications related to ORF Year 1 efforts

ASA (American Society of Anesthesiologists Conference) 2004: Acceptance and usefulness data

Dexter F, Epstein RH, Traub RD, & Xiao Y. [Making Management Decisions on the Day of Surgery Based on Operating Room Efficiency and Patient Waiting Times.](#) *Anesthesiology*, 101(6):1444-1453. 2004

Dutton R, Hu P, Seagull FJ, Scalea T, Xiao Y, . [Video for Operating Room Coordination: Will the Staff Accept It?](#) *Anesthesiology*: 101: A1389. 2004

ATA (American Telemedicine Association Conference) 2004: System architecture and applications

Hu PF, Xiao Y, Mackenzie CF, Seagull FJ, Brooks T, LaMonte MP, & Gagliano D. [Many to One to Many Telemedicine Architecture and Applications.](#) *Telemedicine Journal and e-Health*. 10(Supplement 1), S-39. 2004

A&A (Anesthesia and Analgesia) manuscripts: Algorithm

Xiao Y, Hu P, Hu H, Ho D, Dexter F, Mackenzie CF, Seagull FJ, Dutton R. [Algorithm for Processing Vital Sign Monitoring Data to Remotely Identify Operating Room Occupancy in Real-Time.](#) *Submitted to Anesthesia and Analgesia*

ATA (*American Telemedicine Association Conference*) 2005: Video Board System (VBS) Design

Hu P, Hu H, Seagull FJ, Mackenzie CF, Voigt R, Martz D, Dutton R, Xiao Y. [Distributed Video Board: Advanced Telecommunication System for Operation Room Coordination](#) *American Telemedicine Association Conference 2005 April 17-20*

Hu P, Burlbaugh M, Xiao Y, Mackenzie CF, Voigt R, Brooks T, Fraser L, Connolly MR, Herring T. [Video Infrastructure and Application Design Methods for OR-of-the-Future](#) *American Telemedicine Association Conference 2005 April 17-20*

SMC (*Conference on Systems, Man, and Cybernetics*) 2003: Conceptual design

Xiao Y, Seagull FJ, Hu P, Mackenzie CF, de Visser J, & Wieringa P. [Distributed Monitoring In a Dynamic Environment: Trade-Offs of Information Access and Privacy.](#)

Proceedings of IEEE International. Conference on Systems, Man, and Cybernetics, pp. 4141-4146. 2003

Xiao Y, Seagull FJ, Hu P, Mackenzie CF, & Gilbert TB. **Distributed Monitoring and a Video-Based Toolset.** *Proceedings of IEEE International. Conference on Systems, Man, and Cybernetics, pp. 1778-1783. 2003*

Patent filing

Two US Provisional Patent were filed on

August 13, 2003 “**A novel system of distributing video and other data for coordination**”

Jan 6, 2005 “**Methods for Delivering Coordination Data in a Shared Facility**” *SN 60/641,917*

Additional Funding

UMMS secured \$100,000 in additional funding from Verizon in support of wireless communications in the Operating Room of the Future.

UMMS has received additional funding to continue research in the Operating Room of the Future Test Bed as a result of a modification to the original Cooperative Agreement.

Appendix 1-A

Schematic Design Prepared by Idea Reserve

Introduction

The University of Maryland Medical System (UMMS) has received initial funding from the United States Army to conduct a study of the potential application of visual information and multimedia systems within the clinical environment. UMMS has begun work to gather corporate partnerships and sponsors, as well as to begin the initial phases of design of the technology systems within the new hospital wing construction named the Harry and Jeanette Weinberg Building. This project is the centerpiece of the Medical System's Phase III downtown redevelopment project located on Lombard Street in Baltimore, Maryland.

With the tremendous amount of information available to today's physicians, the collection, routing, and distribution of information, especially visual media, will be a critical component in the success of the clinical mission of healthcare in general into the 21st century. This first phase of the project is the genesis of a comprehensive research study into the visual information needs within the clinical environment that can be used to enhance efficiency and improve outcomes. As such, the project will revolve around a centralized Video Hub (VH) that will act as the focal point for the dissemination of media to and from the Operating Room of the Future (OR) and its connection to resources and collaboration available from around the Medical System and around the world.

MOBILITY, AGILITY, RESEARCH



The promise of the OR of the Future is great. Imagine a future where doctors walk about the OR, the Hospital, or the Community wearing "flip goggles" that, when engaged, enable them to see live video from patient procedures. Imagine a future where doctors in meetings, or in transit, can receive DVD quality images directly onto their Personal Digital Assistants or PDAs. It's not for everyone, certainly, but the technology is progressing to this end: high-quality video images over wireless equipment that enables maximum

mobility and agility.

Research opportunities abound for the project:

How much can we press the envelope of mobile digital video?

How will the adaptation of multiple use video change the way we work?

What partnership opportunities exist between UMMS and other organizations?

What changes will occur in imaging, storage, patient records?

What developments can we realize in the proctor/preceptor roles?

When and How do we migrate from "watching and saying OK" to mentoring multiple exposures?

What data access will be necessary for immediate access and comparisons?

The questions are unlimited.

HOW TO READ THIS DOCUMENT

This document is broken up into several sections. Information is cross-referenced for your convenience and ease of understanding. Following this two-page Narrative Executive Summary, the document gives a “big picture” definition of the critical areas of concern:

Key Clinical Requirements and Expectations

Key Design Concepts

Business Considerations

Project Scope, and

Solution Alternatives

Following these pages, a more detailed, more exacting narrative follows. It explains the technical pros and cons of the various alternatives and tells the full story of the multiple options before UMMS today. Finally, the Appendix Section provides additional information about the costs, the equipment, and the people involved in this effort.



The mission of the OR of the Future is to advance knowledge, foster collaboration, and to help members compete for research funding in their respective areas of expertise in operating room suite management, patient safety and advanced surgical technologies. In keeping with this mission, the OR of the Future Consortium helps its members pool resources and access collaborative programs in order to influence the development of technology and human interfaces in the operating room.

Key Clinical Requirements and Expectations

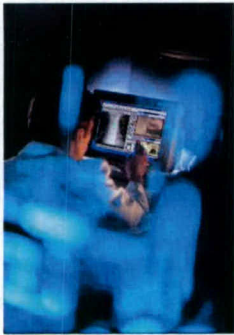

The following “Key Clinical Requirements and Expectations” will be utilized in the development of the solution. These concepts will guide the design so that the result is a comprehensive answer to the needs presented by UMMS professional staff during several meetings and discussion groups conducted over the past two months.

- To Build a Turnkey Solution – The Final System Solution for the OR of the Future must be seen as a “turn key” operation, meaning that after all the input is gathered and the design schematic is worked through, UMMS will implement a Final System Solution with a SINGLE POINT OF RESPONSIBILITY where ONE VENDOR CONTACT NAME will be responsible for servicing and maintaining ALL components of the Final System Solution.

- **Highest quality image for intraoperative images:** Efficacious readings of medical images rely upon the quality of the image; such quality concerns resolution, motion, edge clarity, and (where applicable) color “bleeding.” The highest quality video images MUST be made available to medical professionals at all stages of system use and must ensure excellent:
 - Brightness/Light Delivery
 - Resolution
 - Color Accuracy

- **Equivalent Images on Flat Screen Monitors:** The use of flat-screen monitors is quintessentially important. All video (analog and digital) must be able to be displayed upon flat-screen monitors. The use of heavy, bulky Cathode Ray Tube (CRT) monitors is a concern to many doctors. Simply stated: it’s a great deal of weight to have immediately above patients.

- **Reliability:** Reliability is of paramount concern. Simply stated, the FINAL system must be designed for 99% “UP TIME” for intraoperative images. This means prudent and forward-thinking planning of support infrastructure and system control; redundancy must provide fail-safe measures for reliability.

Ensuring UP TIME means the effective design of a system that works, is intuitive, and has engineered redundancy so that, in the event of a technical difficulty, the system has an effective “backup” methodology in place so that problems are kept to an absolute minimum during:

Procedures, and

Non-Procedure time periods.

In the event of technical difficulties, users of the facilities must know exactly what to do, if anything, to engage redundant systems, to gain technical assistance, and to report any technical complications so that immediate repairs and service can be performed.

- **Ease of Use & Consistency Across OR's:** If medical professionals can't easily use the equipment, they will roll it aside in favor of something that is easy for them to use. Thus, the FINAL system must be designed with full consideration of professional human interaction. All functionality must be "three buttons or less" away for working practitioners. Further, whatever is available in one OR must be available in all OR's. A system that requires doctor's to remember where they are and what features are available to them in specific rooms will *not* satisfy clinical requirements.
- **Research Support** – In addition to assisting practitioners in the every day use of the new ORs, the OR of the Future must aid the further research and development of new uses of video in static and mobile settings or in scenarios where all the doctors, assistants, and patients can not be in the "same place and time." This is a key driver for the Army's research involvement with UMMS.

Key Design Concepts

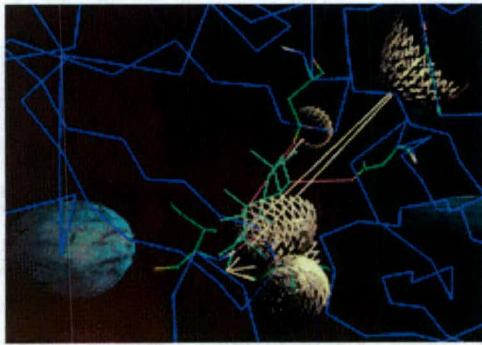

The following “Key Design Concepts” will be utilized in the development of the solution. These concepts will guide the design so that the result is a comprehensive answer to the needs presented by UMMS professional staff during several meetings and discussion groups conducted over the past two months. A list of the personnel involved during this phase of the project can be found in Appendix D.

- **MANY to ONE to MANY** – Information from numerous sources are brought to a central location where intelligent decisions are made as to where the information should be routed. The key issues addressed by this concept are *Flexibility* and *Functionality*.
- **SECURITY** – The system will handle extremely sensitive patient data and thus requires a high duty of care in determining the appropriate levels of access to it that will be provided by this system. *Regulatory Compliance* and *Risk Management* will be addressed by this concept.
- **RELIABILITY** – Future clinicians will come to rely upon the capabilities of the system that is proposed in this document, therefore, the system must be available for use and provide accurate data to the clinician at all times. The system’s reliability will directly impact the *Standard of Care* and the *Utility* of the OR.
- **QUALITY** – Clinicians will be utilizing the visual information from the system to make critical decisions relating to patient care; the visual information must presented to the clinician at such a high degree of quality to allow for exceptional decision making and continued outstanding patient care. *Accuracy* of the images and the *Responsiveness* of the system will be measured by this concept.
- **MOBILITY/WIRELESS** – The ability for information to “move” with practitioners is key to long-term success of the OR of the Future. Included in discussions of mobility, considerable care must be exercised in designing methodologies for discreet data and other secure information relative to patients.

- **NETWORK INFRASTRUCTURE & BANDWIDTH** – Ensuring that the UMMS Computer Infrastructure can support the continuous flow of multiple MPEG2 level video images is a paramount concern. Equally important is ensuring that the flow of high-quality video data also does not disrupt normal infrastructure traffic such as email, web use, and data searches.
- **STORAGE** – The everyday use of high-quality video images will also present the System with a data storage issue. Video files are large, especially when compared to common use files such as email. Practitioners who become dependent upon the use of DVD-level video will also have file storage requirements that are significant.

BUSINESS CONSIDERATIONS

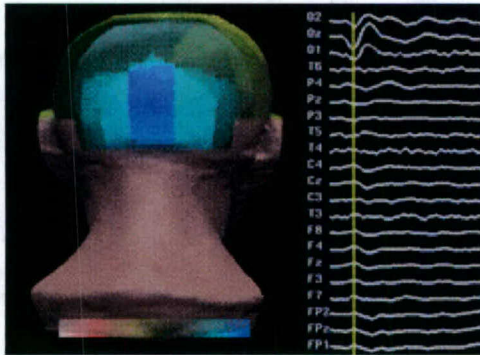

The system must provide a rich level of functionality for an appropriate level of cost. Both the initial investment as well as the life cycle costs of the system must be fully understood. All partnerships UMMS enters into must return value to UMMS. Future management and maintenance needs of the system must be considered. The level of functionality of the system must justify the investment of time, money and resources required to achieve the vision. In executing a decision and designing the solution for the OR of the Future, these Business Considerations were discussed in great detail:

- **Plug and Play Technology** – All equipment and interfaces must be easy to use and must not require a technical degree to install, operate, and manage. It is important to understand this basic principle: a system can be technically fully function but without merit to users IF the system is so complex and is built upon a base of proprietary technologies. Additional and new equipment should be easy to integrate into the system by non-technical personnel.
- **Disruptive Technologies** – Such technologies can have both positive and negative effects on a community of users. Some can be BOTH positive and negative. Email, for example, was at one point an emerging “disruptive technology.” Today, everybody uses email, but, at first, adaptation to email was painful for many users and administrators. The OR System must be designed to easily integrate new, emerging, and otherwise “disruptive technologies.”
- **Medical Manufacturer Markups** – In some cases, potential vendor pricing of equipment “healthcare industry video technology” is marked several hundred percentage points. In creating the OR System, we must ensure that all Medical manufacturer markups are kept to a minim so as to maximize UMMS’ capital investment.
- **Vendor Engineering Design Capabilities** - In many cases, vendors will represent to potential buyers that they offer “the only” solution to a technical problem. In truth, there are many leading, break through engineers around the globe – people who write and re-write algorithms and create candidate solutions. IdeaReserve must help UMMS determine where best to “sole source” any portions of the OR System.

- **Proprietary Components** – Vendors with gifted engineers who build upon the talents of the few leading, world-wide thinkers do develop proprietary components to systems they offer as “whole solutions.” In such cases, UMMS may decide to employ a specific manufacturer’s tool (e.g. a switcher or software). All such decisions should be made with a full understanding by concerned parties.

We do not recommend UMMS integrate any proprietary components into the ORF. All of the hardware and software needed to support the ORF is available as COTS (Commercial Off The Shelf).

OPEN ARCHITECTURE

At the core of the design of the OR of the Future is the commitment to an open architecture infrastructure which means, essentially, that UMMS can (relatively) easily add, subtract, interface, and operate multiple systems provided by multiple vendors and gain the benefit of diverse systems, applications, and functionality without those same systems crashing, conflicting with one another, or requiring very sophisticated and/or expensive custom interfaces to be developed on a case-by-case basis. Probably the best examples are to be found in the Microsoft "plug and play" concept. However, every piece of computer hardware, and most software, does have some limitation today on how widely it can be plugged into other vendor's boxes. This, however, is not a "manufacturer's restriction" it's inherent in the hardware and/or software design and operating methodology.

The selection process for products, and edge devices will favor vendors and products that can demonstrate a highly flexible, adaptable, and fluid capability to operate seamlessly with and in the presence of the products and services of other vendors. The centerpiece and core of the relationship with a primary vendor is the creation of an open architecture infrastructure. In particular, UMMS envisions FIVE aspects of OPEN ARCHITECTURE that are of particular relevance:

1. *Concerns At the Physical Layer* - UMMS needs to, without restriction, be able to modify, manipulate, and change any of the physical hardware that is purchased for use in conjunction with the ORF. However, there must be a process for tailoring the System such that vendors that support the System retain the rights of their intellectual property. Approval for UMMS to make changes to the System will not be arbitrarily withheld.

2. *Concerns About Manufacturer Restrictions* - UMMS must be able to use multiple vendor COTS (Consumer, Off-the-Shelf) Equipment in outfitting the System. (e.g. UMMS should be able to plug in a Storz piece of equipment into a Stryker piece of equipment without violating any agreement/patent/etc.) However, UMMS must develop a discipline for changing and adding to the System so that a single responsible maintenance party can keep track of all System developments.

3. *Concerns about Software* - There cannot be any proprietary software keys/codes that would prohibit us from achieving one or two above. Any codes should be kept in escrow for UMMS to access, again stressing the discipline and collaborative nature of the core vendor relationship. UMMS is not looking to violate any intellectual property rights of the vendor; at the same time, UMMS needs maximum agility for a successful ORF.

4. *Concerns About Maintenance Restrictions* - We must be free to maintain all of the equipment with our own staff, with the vendor's staff, or an independent third party. There should be very few, if any, restrictions on who is "certified" to maintain the system, and these restrictions should not be vendor specific.

5. *Concerns About Collaboration* - UMMS understands the competitive world that exists for the vendors and manufacturers of components and electronic equipment and software. At the same time, the ORF is, at its core, a tremendous collaborative effort between UMMS and the United States Army. As such, it is the goal of the program to develop working relationships that are mutually beneficial.

Project Scope

This assignment will provide the design specifications for visual information technology within the following areas of the Weinberg , Gudelsky, and North Hospital Buildings:

- Operating Rooms (OR)
- Post Anesthesia Care Unit (PACU)
- Surgical Intensive Care Unit (SICU)
- Video Hub (VH)
- Nursing Command and Control Center (C3)
 - Future:
 - Conference Rooms Near O.R.
 - Classrooms

Solution Alternatives

Three potential solutions were considered to achieve the Operating of the Future design concept: an all-Analog solution, a completely Digital solution, and a Hybrid solution. Each offers its own strengths, weaknesses, and opportunities as they relate to the *Key Design Concepts* via UMMS Network to Surgeon's Offices, and via Internet to world outside of UMMS.

- **100% ANALOG VIDEO** – An all-analog solution satisfies some of the OR requirements very well, but is unable to answer all of the needs of the system. An all-analog solution would be very reliable, as the technology is mature, and it provides a high quality image for intraoperative images. The system can be very well secured, as it essentially would run over its own private network utilizing dedicated coaxial cable. However, this strength in security is also a weakness in flexibility. Access to the system is restricted to those personnel physically connected to the private stand alone network. Extending an analog solution over great distances leads to degradation in signal strength and quality. Due to these limitations, an analog solution does not meet the Many to One to Many design concept.
- **100% DIGITAL VIDEO** – An entirely digital solution can certainly meet the Many to One to Many design concept. Running the system over the LAN provides UMMS with a great degree of flexibility and access for anyone associated with the UMMS network. Relative to an analog system, this does create a security issue; however, as additional software programming will be required to create a secure network for the digital information. MPEG2 Videoconference digital video can match the quality of image associated with analog video, though reliability of an all digital solution is not as strong as the analog alternative. New developments in digital technology are happening over time, and as the technology matures, its improvements will as well. IP-based Narrow Band Videoconferencing can be distributed to distant sites.
- **HYBRID SOLUTION** – It is possible to leverage the strengths of both alternatives while minimizing the risks associated with each. By designing a solution where basic functionality of bringing video information into the OR via secure, reliable analog systems, and then utilizing the advanced capabilities of digital technology to disseminate that information outside the OR, UMMS is able to achieve the vision laid out by its professional staff. The proposed solution described in this document addresses each of the design concepts and offers minimal risk to success of the project, as well as enables UMMS to take advantage of future technological advances without having to re-design the system.

- **Proposed Hybrid System Design**

ideaReserve proposes a Hybrid solution, combining both analog and digital systems to bring multimedia technology into the following clinical spaces. These spaces will be connected to the Video Hub for routing and distribution of the information, but control over display of the information will be controllable from a switching module inside the OR.

- **FIFTEEN (15) Camera Equipped Operating Rooms w/Intra-Room Switches** – These spaces will be connected to the Video Hub where the activities within them will be monitored and distributed for coordination of care and research uses. There is a potential for 18 OR's and locations around the UMMS community and for additional hubs for Flat Panels Sign Routing Picture-in-Picture (PIP) & Split Screen applications.
- **FOUR (4) Fully Equipped Operating Rooms** – Clinicians within these spaces will have access to a wide variety of visual media and patient information to be displayed on multiple screens within the OR. Procedures will be able to be recorded and transmitted across the UMMS LAN, the Internet as necessary or archived for future analysis. Video conferencing will be able to take place real time for teaching or consultations. These spaces will provide clinicians maximum flexibility in how they use and distribute the visual media available to them.
- **FOUR (4) Mobile Systems** – These systems will provide two way digital video and audio communications on mobile carts, and be able to be used in any room with a connection to the UMMS LAN.
- **Two (2) PERIOPERATIVE Command and Control Center** – A multimedia PC will be equipped to allow for viewing of procedures and control of information within the OR's. This PC will be located as deemed appropriate for access and use by the nursing staff. One is for the Nursing Station; One is for the Anesthesia Station. All have the same signals, and the same hub with the ability to see all rooms live.
- **One (1) Video Hub** - The VH will act as the "brains" of the system. All information will be routed through this nerve center as it passes to and from the OR. High resolution displays will allow for viewing multiple simultaneous procedures. Routing of information will be conducted from this location. Storage and retrieval of procedures and sensitive patient data will be controlled as determined by UMMS professional staff at the VH. When necessary, control of the systems can be transferred to the OR itself, or to the C3.

Cost Estimate (Appendix A)

The system as designed is estimated to cost \$3,810,304 including installation.

Key Clinical Requirements & Expectations

TURNKEY SOLUTION

Simply stated: people are busy practicing medicine; the technology in place in the OR of the Future must make people's lives easier, not more complex. From experience, we know that working equipment can and does go unused because people have no clue how to operate the equipment. Thus, the systems available to OR of the Future practitioners must be easy to use and integrate into an already busy day's work.

Single Point of Responsibility – there must be ONE vendor point responsible for all aspects of the technical installation, the software integration, and the full-scale set up of the Final System. In common, street terms, ideaReserve calls this the SINGLE “Rolodex Card” philosophy: if something breaks down or there's a glitch of ANY sort, UMMS needs to dial ONE contact and have him/her take charge and immediately address the issue.

Service – There will be technical problems and complications. To pretend otherwise is irresponsible. To embrace this reality in the design process is to best engineer a successful System Solution. In determining a vendor for the Equipment Installation and Integration, we must ensure that the turnaround time for problems is minimal. The chosen vendor must have 24/7/265 service with a FIXED STAFF who know and understand the UMMS system and how the OR functions.

HIGHEST QUALITY IMAGE FOR INTRAOPERATIVE IMAGES

There are three “measures” of image quality that we must be concerned with, they are:

Brightness/Light Delivery – What is the lumens output of the monitors and all equipment that immediately affects the image that doctors will see on flat panels, in their offices, and via any other display tool?

Resolution – What is the maximum output of the cameras and the monitors and what, if any, signal-to-noise alterations affect final image quality?

Color Accuracy – Color “bleeding” and “color change” is of critical concern. The best way to describe this phenomenon is to imagine going to a store to buy a TV. There, along a huge wall of TV sets are the same football game shown over and over and over again. If you notice, the same game can look quite different. We must ensure that the color of an internal organ looks on a monitor as it does in real life. The repercussions could be great otherwise.

EQUIVALENT IMAGES ON FLAT SCREEN MONITORS

The chosen output monitor is the Flat Panel Display. The machines themselves are lighter, easier to move about, and weigh considerably less than traditional CRT monitors. However, the image quality on flat panels often can leave a great deal to be desired. Several doctors told of visiting other hospitals that had the expensive flat panels available; but they reported, the doctors pushed these units aside in favor of traditional CRT screens. They did so because of the brighter images and the increased (in their minds) "resolution."

Technically, the flat panels may have had higher TECHNICAL RESOLUTION; however, in practice, they were brushed aside because they made life more difficult. This tells us two very important things:

Determining the Final System Solution cannot be based solely on technical specifications and product cut sheets, and

We must PROTOTYPE the equipment we will use in the Final System.

RELIABILITY

We cannot over state how important reliability is in the design of the Final System Solution. Simply stated: when people go to the equipment, it must work and it must be easy to use.

As noted earlier, people are busy and the technology needs to make life easier. We must put into place a System that fast enables practitioners to make critical decisions and to share this critical information with others involved in a procedure.

We must ensure that proper steps are taken to ensure system backup and redundancy. Problems will occur; but we must factor that into our advance plans. If people attempt to use the equipment and it fails, it will be difficult, if not impossible, to get them to give the System a "second chance."

EASE OF USE ACROSS THE ORs

The System must look and be the same from one OR to another. Simply stated, we cannot have doctors trying to determine what tools are available to them based upon what room they happen to be assigned for a procedure.

The way we achieve this is by ensuring similar information is available from room to room AND that the software interface, that enables people to interact with the System and the Information, is easy to use and, too, is the same as from the various rooms and terminals in the OR of the Future.

RESEARCH SUPPORT

The System is called the OR of the Future for a reason: it MUST help today's practitioners learn so that we can continuously design improvements in the future. Not only will the System engage practitioners in immediate procedures, the System must allow and encourage research for mobile use of video.

The OR of the Future must also facilitate both the evolution of existing technology AND the continuous exploration of new technology. Equally important, the facility must enable researchers to consider the human factors and OR efficiencies in the coordination and delivery of patient care.

Paraphrased from the orofthefuture.org web site:

Potential areas of surgical research are likely to include:

1. patient safety;
2. investigation of new technology and the evolution of existing technology, such as robotics and 3-D imaging, in conjunction with the analysis of human factors upon new and evolving technologies;
3. operating room efficiency, including the coordination of care, and an enterprise approach to operating room management.

Key Design Concepts

Our discussions with UMMS personnel provide us a unique view into the expected technologies. It is clear that the members of the professional staff see information technology as a driving force in their plans for the future. At the same time, these individuals recognize the importance of applying technology only where it makes sense to do so. Hence, the underlying vision for technology became "Targeted Technology," meaning creating a reliable baseline (which may itself evolve over time) of technology for the OR user community while targeting specialized areas for more advanced technology. The use of established, reliable technologies will be coupled with advanced systems to provide maximum functionality, reliability, and utility.

MANY TO ONE TO MANY

The gathering and distribution of visual information, which we will define here as video from medical instruments, cameras, and recordings; imaging; text; graphics; and medical records from throughout the clinical spaces and the "outside world" will follow the MANY to ONE to MANY concept, where a variety of input sources both internal and external to the OR (MANY) provide information to the VH (ONE), it is classified and then re-directed to the desired location(s) (MANY).

This design concept is intended to foster maximum utilization of dynamic medical information across the Medical System. The "Many to One to Many" concept brings to the VH a tremendous amount of relevant information for the clinician in the OR where the clinician can determine which bits of this information is required to enhance their work and thereby the outcome for the patient. In addition, the information can be distributed as the substance of OR procedures either for a consultative video conference, archival for later analysis, or streamed to be used for educational purposes. This design approach currently in use at the UMMS Shock Trauma Unit will be a guiding principal for the design of the technology systems in this project.

The key issues that this design concept seeks to address are defined as follows:

Flexibility – The system must be capable of growing easily, acquiring new data sources and including new communications destinations with minimal manual intervention. The system within the OR should be capable of receiving data from up to 12 sources and transmitting data out to four (4) destinations. The system must operate on an open architecture with access to a variety of standardized networks such as IP, ISDN, and the WWW.

Functionality – Access to the data alone is not sufficient. The data must be easily manipulated so that the clinician is not limited by the technology. The visual information provided by the system should be controllable from a variety of locations, such as within the OR, the Perioperative and Anesthesia Nursing Command and Control Centers, and the Video Hub. Any properly equipped PC on the UMMS network should have secured access to the data streams produced by the OR.

SECURITY

Protecting sensitive patient information is a critical concern to UMMS. Thus, the management of the recording, archival and distribution of the activities within the OR become increasingly relevant as a security concern. By providing clinicians access to information they previously did not have, a window is opened for access to that same information by non-clinical personnel. An X-Ray on film filed away in a records room is secure. A digital image of that X-Ray stored on a server that is connected to the network needs to be made secure. In the design of this system, great care needs to be given to the issue of security, and just as technology will provide the OR an increase in functionality, it can also be used to create a secure environment for the use of sensitive patient data.

Regulatory Compliance – Recent government regulations such as HIPPA have put constraints on access to patient information. As technology provides greater opportunities for access to information, care must be given to restricting that access appropriately. The design of the system will include functionality to monitor compliance with all relevant government regulations.

Risk Management – Maintaining compliance with government regulations, limiting access to sensitive patient data, and compiling a visual record of activities within the OR will limit exposure of UMMS to liability. Through the use of information technology, the OR will become a more efficient environment with a greater standard of care.

RELIABILITY

In order to provide an outstanding level of patient care, any system design must address the issue of reliability. Systems and technologies that will be incorporated into the every day practices of the OR must be available for use by clinicians at all times. Critical patient data that key decisions will be made on will become essential and access to that data must be seamless. There can be no significant delays between the request for the information, and its appearance. The system can not "go down" or have interruptions in service. The standard for this system, because of its mission, will be as high as that of any other piece of technology in use in the OR today.

Standard of Care – The critical success indicator for any change to the activities within the OR is whether or not care to the patient is improved. The system will consistently provide high quality visual images to the clinician within the OR reliably and in an appropriate time frame. By providing the clinician with the correct information at the appropriate time, critical decisions relative to patient care will be made more accurately.

Utility – While processes within the OR may change, they will not be made more complex. Every function within the clinical space will be limited to the "3 button" rule. Each action will only take a maximum of 3 steps to complete, whether it is acquiring a data stream for display in the OR or setting up a consultative teleconference with a clinician outside of the UMMS environment.

Just as the lights and air conditioning will work as a utility within the ORF, the multimedia systems must also work.

QUALITY

The quality of images presented electronically to the clinicians within the OR must meet or even exceed the quality of those images presented in traditional media today. As clinicians use these images to make determinations on care provided to UMMS patients, the information must be accurate. Variances in the images due to failures or shortcomings of the system will not be tolerated. UMMS clinicians working within the OR have become accustomed to a high standard of quality for visual imagery and display. This standard must continue to be upheld. The technology to meet this demand is certainly available today, and the design of this system must incorporate that technology in the best manner possible.

Accuracy – In order to make consistently accurate decisions based upon visual information, the information can not be distorted in any way by the technology used to display the media. The visual information displayed by the system will be of the highest resolution and clarity possible given today's technology.

Responsiveness – The time spent between the request for the information is made by the clinician and the data is presented can not impact the standard of care given to the patient. High quality visual information will require significant amounts of bandwidth from the UMMS network. The system will be designed to allow the information to be displayed as soon as the request is processed. The technology will not be the limiting factor in the time taken to display the requested data.

MOBILITY/WIRELESS



The ability to be agile is paramount to the short-term and long-term success of this project. The information needs to flow freely as do the people involved in procedures. From the beginning, practitioners will no doubt be limited due to the current advancements of wireless technology, especially wireless VIDEO technology. In other words, today's wireless video image on a PDA would look more like a smudge than a clear image. The technology is not sufficient at this date; however, the technology develops.

If we can today image doctors sitting in meetings and proctoring procedures, if we can imagine doctors seeing something in these images and immediately making contact back with the OR, then we must consider the mobility ramifications today. These are potential POSITIVE disruptive technologies as they would, in some cases, eliminate the need for monitor screens.

NETWORK BANDWIDTH

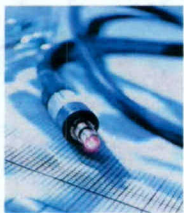

The System must be able to function over the UMMS network. ideaReserve met with those charged with providing the network to the UMMS community and verified that the network bandwidth available at UMMS is sufficient to meet the needs of the large video files that will travel over the network.

The question has come up: will the System require 100Mbps or 10Mbps ports? The approximate size of MOST video files that will traverse the network will be 6Mbs-8M. Thus, 100M ports are best as the 10M ports may reach capacity frequently. 10M ports will work, but 100M ports are best. Based on 6Mbs per video stream, the current UMMS network standard of 100Mbps switched to the desktop and Gigabit backbone architecture should be sufficient to distribute the approximately 40 MPEG2 video streams that we currently envision.

STORAGE

The storage requirements to support this project could be tremendous. This will likely be one of the very first technology-related research aspects of the OR of the Future. DVD TAPE, DVD, Video on Demand, Instructional Use of Video into Classrooms may require terabytes of storage. Currently, a Recordable CD can handle 30mins of MPEG2 video. The question of whether storage should be LOCAL or REMOTE must also be addressed. It could easily be handled remotely over a wideband network.

BUSINESS CONSIDERATIONS

As with any endeavor of this magnitude, UMMS must receive value for their tremendous investment of time, resources and, of course, money. The system delivered must allow for growth, both in size, and scope. It must be able to evolve as technology changes and improves. It must not restrict UMMS from utilizing any future developments in technology or require a massive redeployment of technology within the usable life of the system. The system must be cost effective in that UMMS receives maximum value, both in terms of hardware and capabilities, for the dollars invested.

PLUG AND PLAY

Utilizing current technology standard inputs and outputs, the OR users will be able to integrate NTSC video in composite and component formats.

The concept of Plug and Play technology is much as a novice to technology might guess. The people operating the systems daily at UMMS will not be technical engineers. From a research perspective, the people operating equipment in the fields for the Army will not be technical engineers. Rather, users who engage and interface with the System will be medical professionals.

The purpose of the OR of the Future is to evaluate emerging technologies, measure their effectiveness against the Human Factors and Coordination of Care issues, and improve care provided to patients. Thus, the approach to technology will be "off the shelf" technology implemented in new and engaging ways. In other words, the OR of the Future is an incubator of sorts for new practices; it is not, however, a technology lab where new pieces of equipment and technical standards are developed.

DISRUPTIVE TECHNOLOGIES

No matter what we put in place on Day One a new technology is ALREADY in development that will “unsettle” the landscape. Many people, when they plan for technology, tend to see an implementation project such as the OR of the Future as a “point in time” that we achieve and then stop. The opposite is true.

Not only do we need to envision and create a technically sound, medically robust system for Day One use, we also MUST consider new and emerging technologies that will come on line and “disrupt” the status quo. It is important to see that ‘disruptive technologies’ are not necessarily a NEGATIVE. Rather, many technologies that are developed than most consider POSITIVE and “helpful” were, at one point, a disruption to that day’s status quo. We used the example of email earlier.

In order to plan for emerging and disruptive technologies, we need to:

- Ensure the current network can facilitate Day One and projected video; it can
- Ensure the switching devices in the Command center can facilitate the many-to-one-to-many video streams, it can
- Protect UMMS against future “forklifting” of infrastructure.

It is important to note that the University will invest in technology that one day becomes obsolete. That’s not a surprise to anyone. What we must protect against is investing in infrastructure that is not to standard or that locks UMMS into a single vendor. Disruptive technologies will come along. No single vendor has all the solutions that UMMS will require into the future.

Other potential technologies include:

CAVERNS

Wearables

IMMERSION Ors

Wide-Bandwidth Wireless

MEDICAL MANUFACTURER MARKUPS

As stated earlier, the healthcare industry has unique needs for technologies that are in use in other industries. And, with that, some vendors have realized the importance of these unique needs and have developed "healthcare only" applications or software that commands and controls these otherwise "off the shelf technologies."

Thus, we have a bit of a balancing act to perform. On the one hand, we do not want to pay four, five, or six times markup for the SAME piece of equipment that has been, effectively, "re-badged" with the nameplate of a "healthcare technology vendor." In some cases, ideaReserve has identified both switching devices and flat panel monitors that were marked up more than 500%. That's an unwise, at best, investment.

At the same time, some vendors have created software applications that "ride" on top of off-the-shelf technology that does make all the equipment function more readily and easily for practitioners. And, as was stated earlier, it is very easy to have a fully functional system of technology that nobody uses because they haven't a clue as to how to get the equipment to perform the necessary tasks.

So the balancing act is protecting UMMS against unwieldy vendor markups and ensuring UMMS practitioners have access to easy-to-operate systems.

VENDOR ENGINEERING DESIGN CAPABILITIES

Building off the balancing act described on the last page, what we have to realize is this: there really are only a relative handful of breakthrough engineers around the globe who are inventing the new mathematical solutions that will one day become "standards." This is NOT to say that there are not a lot of talented engineers at vendors around the world. There are. IdeaReserve spoke with excellent minds at AutoPatch, Crestron, Extron, Pioneer, Stryker Communications, Synalec, and V-Brick for this effort.

Each of these companies brings a great lot to the table, most importantly, their engineering intellect. But it is important for everyone to understand that NO ONE COMPANY provides all that makes up the final solution. Each company is dependent upon other companies, and their engineers, for survival.

Thus the distinction becomes important to UMMS. On numerous occasions, people asked whether one company was, in deed, the ONLY supplier for the OR of the Future solution. The answer is a simple "no." Then it gets complex again, starting with the next page.

PROPRIETARY COMPONENTS

Continuing to build on the last page, it is important to understand that some companies engineers have developed proprietary components that “ride on top of” other companies products in order to bring a meaningful solution to practitioners who otherwise could care a less HOW the technology is working to help them.

An example is Stryker Communications. There is no doubt that Stryker Communications has developed an incredible component control software for practitioners. Stryker is a well-know, incredibly diverse, medical technologies specialist. Their company is a leader in understanding how doctors and nurses work. They’ve taken this information, leveraged the skills of their talented engineers, and developed a simple-to-use touch control software, that is, in a word, EXCELLENT. And it is Strkyer’s property—and rightfully so.

But the software doesn’t work without multiple products that are made, manufactured and sold at vastly reduced prices from numerous vendors. Not only that, the control systems (such as Extron and Crestron) come with icon-based software packages that can mirror what Stryker’s software does.

Thus the balancing act gets more complicated. The goal is to not re-invent the wheel but to also not pay 500% markup to anybody. COTS (Commercial Off the Shelf Technologies) will make up the ORF System.

Solution Alternatives

The Operating Room of the Future, Phase One Design must speak to and answer the following questions:

1. What multimedia information is available and required for the OR?
 - a. Where does the Hospital controlled information reside and in what format?
 - b. What "Real World" sources exist and how will this data be passed to the system?
 - c. How will information from a variety of sources in a multitude of formats be gathered, managed and distributed?
2. Who are the intended recipients of this data?
 - a. Who within the hospital requires this data and how will they receive it?
 - b. What outside parties will the information be available to and how will they access it?
 - c. What will the standard format be for the data to be disseminated?
3. How will the information be gathered, controlled and disseminated?
 - a. Which organizations have ownership/control of the patient information?
 - b. How will the system be impacted by HIPPA?
 - c. How will the technical configuration of the information affect the tele-health standard?
 - d. Who will be allowed access to the data? How is eligibility determined?

In addressing these issues the project team must take into consideration several mitigating factors. The solution must balance physician needs with human factors. Technical systems must be physically secure and maintain privacy of patient data. Systems implemented must provide an open architecture to allow maximum flexibility in utility. All systems must maintain a high standard of reliability as well as be intuitive and easy to use. Any solution implemented that does not adhere to these standards will not be successful.

This document will become the basis for an UMMS "telehealth" standard that will serve as the design protocol for future OR's. This document will provide the design philosophy for distribution of information to and from the OR, and begin to define voice, data and video communications that are possible or necessary to provide the clinician within the OR the correct information, in the proper format, at the appropriate time.

The focus of this document will be on the systems concepts that will enable the flow of information between the OR, the VH, and the outside world, and what equipment will be required to implement the recommended approach. A budget of \$800K has been allocated to implement a solution. This facility will utilize both robust legacy and the latest technological achievements to voice, data and video communications to achieve the project goal. The design

must be flexible to support the ever-advancing technologies and applications available for the OR.

The purpose of this document is to assist with the design of a robust, scaleable VH for effective use of spaces and technologies that can grow without “fork lifting” the solution to make way for “better” technology. The control and distribution of media to the OR spaces is essential for a variety of reasons that includes increased patient safety, efficient OR scheduling, and administration. An effective infrastructure design enhances innovation and allows access to data sources that are both internal and external to the facility.

The 100% Analog Option

Background

Analog video is defined as baseband, composite video based on the EIA RS-170A standard, originally issued in November of 1953 as RS-170, and is sometimes inaccurately referred to as “uncompressed video”. This document is the EIA broadcast studio standard for the NTSC (North American Television Standard Committee) video format. It consists of definitions, minimum standards, and methods of measuring important standards for the 525 line interlaced TV system. It describes a 2:1 interlaced signal where a total number of lines occur over the period of a 30th of a second. The horizontal frequency is 15,750 Hz, which is derived from 525 lines per complete picture x 30 pictures per second. The vertical frequency is 60 Hz because of the 2:1 interlace. The video signal is defined as 1.4 volts peak-to-peak. This has been the industry standard for the transmission of video information for four decades.

Correlation with Design Concepts

Many to One to Many

This is a “mature” network technology based on a point-to-point system of largely coaxial (coax) cable, although optical fiber and twisted pair can be used as a distribution media.

Flexibility - Analog technology allows for a scaleable network design by adding new runs of cable to locations that require service, provides ease of use of the system, and has a “standards-based” architecture. Analog systems are limited, however, in their ability to distribute the procedure captured in the OR to a wide variety of locations limiting the many-to-one-to-many design concept. Unless you have a hard-wired connection to the system, you will not be able to access the visual information flowing across the system.

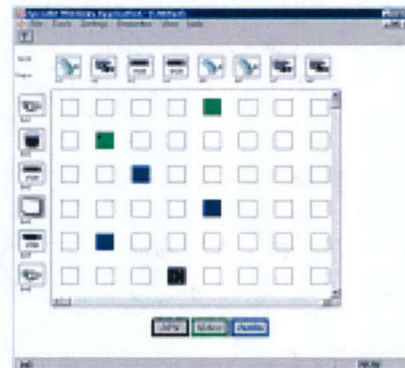

Functionality - Storage of analog data becomes cumbersome and costly as either videotapes must be recorded and stored, or a digital storage system must be added and integrated. Implementing an analog solution does not fully leverage the robust data network already in place at UMMS.

Security

Analog systems do offer a high level of security as the solution creates a private network, not connected to a system-wide network, to carry the video signal.

Regulatory Compliance -

Risk Management -

Reliability

The system is highly reliable and relatively inexpensive because of the maturity and availability of equipment and technology.

Standard of Care –

Utility - UMMS personnel are familiar with and satisfied by these analog systems in use in current facilities. Maintenance of an analog system is relatively easy; the technology has been in place and has been standardized.

Quality

Accuracy – An analog solution delivers a high, “broadcast” quality image with reliability, one with limited latency (jitters), good color rendition, and adequate resolution.

Responsiveness –

Business Considerations

Plug and Play –

Disruptive Technologies –

Medical Manufacturers Markups –

Vendor Engineering Design Capabilities -

Proprietary Components -

A detailed schematic of the 100% Analog Option is provided as part of Appendix B.

The 100% Digital Option

Background

Video is typically analog at its source and destination and is converted to a digital signal for transmission. Without compression, a single video stream would easily dominate the bandwidth of any network. To reduce the bandwidth to more manageable levels, the video stream is compressed using the current industry standard MPEG.

MPEG (Motion Picture Experts Group) is the acronym given to a family of International Standards used for coding audio-visual information in a digital compressed format. MPEG standards include MPEG-1, MPEG-2 and MPEG-4, formally known as ISO/IEC-11172, ISO/IEC-13818 and ISO/IEC-14496. MPEG is originally the name given to the group of experts that developed these standards. Established in 1988, the MPEG working group (formally known as ISO/IEC JTC1/SC29/WG11) is part of JTC1, the Joint ISO/IEC Technical Committee on Information Technology. MPEG-1, is the standard on which such products as Video CD and MP3 are based. MPEG-2 the standard on which such products as Digital Television set top boxes and DVD are based (and is the proposed standard for the distribution of medical, visual information) and MPEG-4, the standard for multimedia on the web. The current thrust is MPEG-7 "Multimedia Content Description Interface".

Correlation with Design Concepts

Many to One to Many

Flexibility – Distribution of digital video signals can be made across the UMMS campus over the LAN and to distance facilities via the internet. Digital solutions offer unlimited multi-casting: a procedure, where visual media is being imported to the OR, is exported simultaneously to an outside clinician for real time consultation, into the media archival system for replay on demand, to a learning theatre for observation by students or other interested parties, or to anywhere deemed necessary along the network.

Functionality - Archival of media is as simple as easy as pressing the "save" button and storing the video information on a digital storage server.

Security

Carrying the digital signal across the UMMS production network poses a potential security issue. Anyone with access to the network could theoretically have access to sensitive or private patient information. Standards for security and quality are still in development for digital solutions due to the fast moving pace of technological advances in this area.

Regulatory Compliance –

Risk Management –

Reliability

Reliability of the system is directly related to reliability of the UMMS data network. The bandwidth drain on the data network is potentially significant and requires extensive testing prior to implementation.

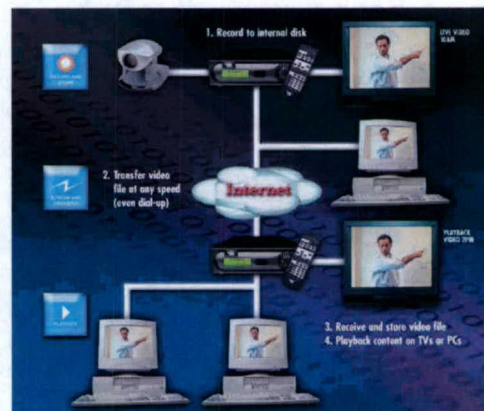

Standard of Care –

Utility - Digital solutions can be programmed to provide the same easy to use interface as with an analog system, as well as allowing access to be routed to any PC on the network.

Quality

Accuracy – A step in the process of compression is MPEG-2. This keeps the resolution at 720 x 480, equal to that of NTSC analog video. MPEG breaks areas of each frame into 8 x 8 pixel blocks, and performs a mathematical function called Discrete Cosine Transform (DCT) to each block. This process packs more information into each block by eliminating redundancies, removing random data points that are not detectable by the human eye, and rounding off data as needed. Because some data is therefore lost, the original accuracy cannot be restored, but the video signal remains intact.

Responsiveness – With these compressed blocks of data, MPEG then re-organizes the data into “macroblocks” of 16 x 16 pixels to compare one frame to the next. Only the changes between frames are significant, so only those blocks that change from frame to frame are needed. This results in additional compression and reduces bandwidth substantially. The future of multimedia information is certainly in a digital format. As technology advances, available bandwidth increases, and therefore speed and quality of service to the user increases, digital solutions are becoming more the standard.

Business Considerations

Plug and Play –

Disruptive Technologies –

Medical Manufacturers Markups – This extensive functionality does not come cheaply, however, as digital solutions tend to be more expensive than comparable analog systems.

Vendor Engineering Design Capabilities -

Proprietary Components -

All of these issues can be addressed during the implementation phase of an installation but requires a significant amount of software and programming to craft a unique solution to the distribution and security of the information.

A detailed schematic of the Digital option is provided as part of Appendix B.

.The Hybrid Solution

As with any combination of alternatives, the Hybrid solution seeks to leverage the strengths of both the analog and digital alternatives while minimizing the exposure of weaknesses. It is possible then to implement simple, robust analog systems within the OR and VH, while providing digital converters to distribute the media over the data network as needed. In this manner the functionality of the digital solution is paired with the reliability and cost effectiveness of the analog system. Storage and retrieval of media can be in either an analog or digital format as delineated at the VH. As new technologies are developed, the Hybrid solution can evolve to provide UMMS with a continually improving baseline of service. It is the strong recommendation of ideaReserve that UMMS utilize the Hybrid solution further described on the following pages to achieve the Operating Room of the Future vision.

A detailed schematic of the Hybrid solution is provided as part of Appendix B.

Proposed Hybrid System Design

ideaReserve proposes a Hybrid solution, combining both analog and digital systems to bring multimedia technology into the following clinical spaces:

- Fifteen (15) Camera Equipped Clinical Spaces
- Four (4) Fully Equipped Clinical Spaces
- Four (4) Mobile Systems
- Two (2) Nursing Command and Control Centers
 - Perioperative
 - Anesthesia
- One (1) Video Hub

These technology spaces will combine to provide UMMS with a robust solution to this Schematic Design development of the Operating Room of the Future. The following pages provide a detailed narrative description of the system design, the capabilities it provides, and the equipment necessary to make it happen.

Fully Equipped Operating Rooms

The key functionality present within the OR's will be the display of visual media. Two (2) 21" screens will be located on a boom above the operating table that can be positioned as needed during a procedure. These screens will be connected to a video switcher that will facilitate the connection and display of the input devices identified as follows, as well as any visual information that may be brought into the OR through a PC screen or via standard baseband video.

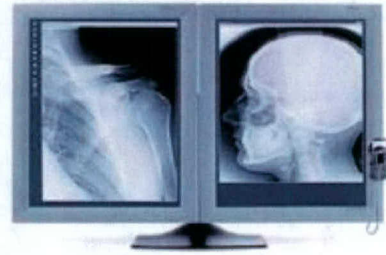

Identified Data Sources:

- Picture Archive Communications System (PACs) – AGFA designed, DICOM compliant medical imaging system, images routed from 8 “gateway” PC’s to UMMS web servers, currently stores over 1 million images on a Sun Enterprise 5000 server, images can then be viewed on any PC, but high resolution terminal is required for accuracy. System houses the following images:
 - X Rays
 - CT Scans
 - MRI
 - Ultrasound
 - Nuclear Medicine
 - Angiograms
- Endoscopic Camera
- Portable X-Ray
- Physiological Monitoring
- Laproscopic Instrument
- Stealth Images – integration of MRI and CT images used for range finding and determination of location within patient
- Cameras from Inbound Ambulances, ICU, Shock Trauma, Pre-Op
- Cardiac Catheter Lab – 15 frames per second X-Ray image, file sizes from 30 to 300 meg, potential for hundreds of images per run and multiple runs, images are transferred over fiber optic connection between lab and mainframe with RAID storage, images can be accessed by any PC on the network
- Personal computers and laptops for patient information, anesthesia, and medical imaging.

System Capabilities

Any video source, whether Analog or Digital, may be connected to up to twelve (12) inputs that may be displayed on the four (4) screens. The displays will each be controlled by a touch panel remote interface that selects which data set or image will be directed to which screen. This will reduce the need for picture-in-picture (PIP) or screen splitting which reduces the image resolution. The remote control system will be integrated into a PC to allow IP-addressable control, scheduling, and maintenance of the equipment. The units will be fully programmable from any assigned PC on the network



and in the VH so that the look of the screen and the control sequences can be adjusted over time to reflect individual preferences. The VH personnel will be able to perform analysis or even take over control of the room systems for research purposes, or in the event of a complex procedure requiring more elaborate interface with the technology. A high-production-value video consultation could be one use for this master control function. The control scheme will be designed to provide an organized format for controlling the array of technology available. The goal is to provide maximum functionality to the user while placing the "burden" of technology on the systems, rather than the users. The "Rule of 3's" will apply so that a person requires no more than three "button" pushes to activate a command or sequence of commands, as in the Shock Trauma system.

The rooms will have "memory" or the ability to easily record, store, and transmit the activity within the room either real-time or asynchronously. Video inputs from two (2) cameras will allow recording and distribution of procedures. Audio signals will be gathered by room microphones. These audio and video signals will be direct connected to the video switcher located in the VH for recording and distribution.



In addition, the equipment will have IP-based video interface to allow incoming video material to be displayed in the room anytime. Via the PC, this system will allow real-time or store-and-forward distance connectivity to and from any UMMS facility, or anywhere in the world. The switch will be connected to an Analog to Digital converter that allows signals created within the room to be directed onto the UMMS network.

These clinical spaces will have a great deal of cabling and interconnected systems within the physical environment. The cameras, monitors, medical equipment inputs, remote control interface, audio systems, and switching will require an extensive amount of physical space and to enhance the reliability of the system by reducing the risk of damage or misconnection by fixing the systems within the room.

Camera Equipped Operating Rooms

Within these spaces, audio and video communications will be the focus of the technology. Two (2) cameras, one fixed on the room, and one pan-tilt controllable from the VH or any properly configured PC connected to the UMMS network, will provide live video feed of activity with the OR. This feed will be routed to the VH for distribution across the network to a distance site, doctor's office, nurse's station, any PC connected to the network, or archival for later analysis. Two (2) microphones, one fixed room microphone and one individual microphone, will capture the audio signals for transmission back to the VH and distribution. Through this system, all activity within the OR can be transmitted either locally or across the internet or recorded for future research use as needed.

Mobile Systems

To provide flexibility, mobile "carts" will be designed to bring high quality, two-way digital video communications to remote clinical areas. The carts will be equipped with a high-resolution display with speakers, have the ability to provide video conferencing through one (1) remotely controlled camera, and be able to display visual information from the VH. The carts will connect back to the VH through the building data infrastructure. An integrated touch panel display enables users to selectively place calls to other mobile systems, and remotely select, control and retrieve live video or medical images from any source via the VH. The system will support one (1) local wired or wireless microphone.



Perioperative and Anesthesia Nursing Command and Control Center (C3)

To provide interface with these units at the OR Suite, we have numerous 24/7 video monitors within the Video Hub that can have all of the OR's on display. This would entail personnel going to the Video Hub to see the full spectrum of activity within the entire OR Suite. In addition, any PC on the UMMS network, including those at the two stations, would have the ability to be programmed to select a digital video image of the OR cameras (or multiple images up to 4) as a picture-in-picture (PIP) window on the desktop. The functionality of a video monitor(s) with all eighteen (18) OR camera's in real time at a separate station is very feasible, but is not currently supported in the cost estimate.



Video Hub (VH)

The major piece of equipment within the VH will be a massive Video Switcher that routes analog signal to the plasma displays within the room and out to fixed locations. A touch panel remote control system will serve as the interface to the switcher. The analog signals will be run through the switcher to an Analog to Digital converter to be routed onto the UMMS network for remote display and archival. In this manner any PC or laptop connected to the UMMS network will be able to receive data from the VH, and remote locations will be connected over the internet or ISDN connection. The VH will provide UMMS maximum flexibility for distribution, storage and retrieval of the video images used by the system. The VH will serve as the “brains” of the Operating Room of the Future and will be the key component for management and distribution of the content developed both in the OR and in the medical imaging departments of the health care system.

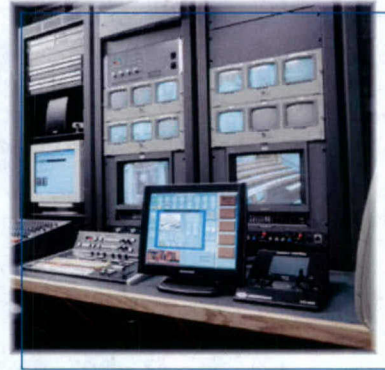

The equipment list and cost estimate for these systems can be found in Appendix A at the end of this document.

UMMC Project Design Team

UMMS

Dr. Jack Flowers, UMMS

Dr. Bruce Jarrell, Overall Program Responsibility, UMMS

Dr. Colin Mackenzie, Physicians Technology Chair, UMMS

Dr. Roger Voight, Director of Operating Room, UMMS

Dr. Yan Xiao, UMMS

Breslin, Mary Jo, Perioperative Representative, UMMS

Schrader, Dennis, Vice President, UMMS

Abate, Tessa, Procurement, UMMS

Burlbaugh, Mike, Project Manager, UMMS

Dixon, Wes, PACs Administrator, UMMS

Ganous, Time, Technical Consultant, UMMS

Hu, Peter , Technical Advisor, UMMS

Minear, Michael N., Senior Vice President & Chief Information Officer, UMMS

Mullauer, Bill , Network Architect, UMMS

Perkins, Sherry , UMMS

Manufacturers & Vendors

Stryker Communications

Lambiotte, Walter, Technology Consultant

Sontag, Brent, Sales Representative

Strombridge, Richard, Vice President of Operations

V-Brick Systems:

Benson, Mike, Senior Director

Feldman, Burt, Video Network Consultant

Wilson, Jim, Territory Manager

Representatives from AutoPatch, Crestron, Extron, Pioneer, and Synelec

Frequently Asked Questions

1. *What are the Key Clinical Requirements and Expectations for this project?*

Highest Quality for Intraoperative Images;
Equivalent Images on Flat Screen Monitors;
Reliability;
Ease of Use; and
Research Support.

2. *What are the Key Design Concepts for this project?*

Many-to-One-to-Many;
Security;
Reliability;
Mobility & Wireless Applications;
Network Bandwidth, and
Storage.

3. *What are the Key Business Considerations for this project?*

Plug and Play Technology;
Disruptive Technologies;
Medical manufacturer Markups;
Vendor Engineering Design Capabilities; and
Proprietary Components

4. *What is meant by the term: "Image Quality"?*

Three factors are quintessentially important in determining image quality for this project:

Brightness/Light Display;

Resolution; and

Color Accuracy.

5. *What vendors will be used in piecing together the FINAL system?*

At this point, there is no answer to this question. IdeaReserve's goal is to work with UMMS professionals to develop a forward-thinking approach that provides an infrastructure that enables OR users to do all that is required from "day one" AND enables UMMS to "grow into" new (and positive "disruptive technologies") easily and cost effectively.

6. *Will the system be easy to use?*

Absolutely. The FINAL System's interface program will not require users to depress more than three (3) buttons) for most applications. The Final System Interface will be icon-based and designed for highly intuitive interaction.

Appendix 1-B

The University of Maryland Medical System Phase III Weinberg Building

OR of the Future

Work Plan for OR Communications/Telemedicine System

Purpose

The University of Maryland Medical System is embarking on the implementation of an OR communications system that will integrate video, voice, and data into a seamless telemedicine application. The system will be of open-architecture, scalable design that shall enable future upgrades and modifications as technologies become available.

The system shall enable the routing of video, voice, and packet-data within an Operating Room Suite to allow customized viewing from multiple locations within each room. The system shall enable video conferencing from each operating room to classrooms and/or direct to desktops within the Hospital, and external communications to remote sites. The system shall also be used to capture video and voice from each Operating Room, PACU bed, and SICU bed to track status of patients and surgical processes.

System Design Functional Requirements

- A. Within Each Operating Room (Total of 18)– the conceptual functional requirements are:
 - 1. Status camera is required for each operating room to transmit video back to central command center (See requirements for command center). Status camera should provide overall view of room, surgical field, support staff, etc. Camera may be fixed. Full duplex voice transmission must be enabled.
 - 2. Two flat panel monitors shall be installed on ceiling mounted booms in each operating room (provided by others). These monitors shall be used to view the following:
 - a. Laparoscopic Image
 - b. Physiological Monitoring
 - c. Video Conferencing Remote Site
 - d. Video Conferencing Local Site
 - e. PACS Image
 - f. Patient Records
 - g. Hospital Network Applications

System shall integrate all of the above referenced video and data to create flexibility in viewing, where any of the inputs from the OR can be viewed on either flat panel or at a workstation placed in the room. Routing shall be actuated through touch panel-type viewscreens.

3. Each Operating room will be enabled to videoconference to classrooms within the hospital, as well as to remote sites via network/ISDN bridge. Viewing of Operating room from desktops throughout the hospital is a preferred feature.
 4. With the exception of the status camera in each room, review alternatives to provide a mobile assembly that accomplishes all of the functional requirements but can be positioned in a room for a case, and relocated as required. A total of four (4) mobile units will be shared by all 18 Operating Rooms.
- B. Within the PACU and SICU – the conceptual functional requirements are:
1. Status camera is required for two (2) PACU beds and two (2) SICU beds to transmit video and voice back to central command center. Full duplex voice transmission must be enabled.
 2. Systems must be mobile to allow for coverage of all 29 existing PACU beds and 12 SICU beds on an as-needed basis. Units shall be relocated to beds holding patients that are being tracked as part of research agenda.
- C. Command Center – Centrally located command center to monitor status of all Operating Rooms and monitored SICU and PACU beds. The conceptual functional requirements are:
1. Monitoring station shall consist of flat panel monitors at the following to (possibly three) locations:
 - a. Nurse's station on 2nd Floor of Weinberg Building
 - b. Anesthesia work room adjacent to Nurse's station
 - c. (Possible) Dr's Work Area adjacent to Nurse's station
 2. System shall allow for split-screen view of multiple OR's
 3. System shall , through touch panel or like process, allow user to select and view on full screen a single OR or SICU/PACU bed
 4. Access shall be enabled through Hospital LAN from any connected desktop to view specific OR's/PACU/SICU.
 5. Full duplex voice communication is required to and from each location, exclusive of desktop access through LAN.
- D. Other Considerations
1. Wireless – Wireless data/voice access should be considered when designing the system. 802.11b wireless data will be deployed in the PACU area, and can be made available in the new space if it becomes a functional requirement of the system. 900 MHz wireless voice system (Spectralink Link 3000) will be deployed in the OR and PACU areas.

2. PDA – Consider access of video signals via Palm Pilot or like handheld device.
3. Image/Video Recording/Archiving – Consider the requirements for video recording and archiving.
4. Scalability – System must be open architecture, and scalable to accept future technologies, upgrades, etc.
5. Standards – The system designed shall become the standard for future installations system-wide.

Design Process

The following briefly defines the proposed design process and schedule:

A. Team Members

1. Dr. Jarrell – Overall Program Responsibility
2. Dr. Voigt – Surgery Representative
3. Mike Minear – UMMS Technology Direction/Standards
4. Mary Jo Breslin – Perioperative Representative
5. Mike Burlbaugh – Project Manager
6. Tim Ganous – Technical Advisor
7. Peter Hu (Contract) – Technical Advisor
8. Design Consultant – Responsible for hard-lined design

B. Proposed Design Phases and Schedule

1. Conceptual Design
 - a. Determine conceptual requirements for system, establish baseline budget
COMPLETE
2. Schematic Design – 6 weeks (March 1 – April 15)
 - a. Meet with surgery and perioperative representatives (Assume 3 meetings) to refine functional requirements.
 - b. Visit similar installations in the Baltimore/Washington area to obtain “hands-on” input on system strengths and weaknesses.
 - c. Develop schematic plans of system
 - d. Determine all additional infrastructure requirements that impact Weinberg Construction
 - e. Develop preliminary equipment list
 - f. Develop schematic level budget
3. Review Schematic Design – 2 weeks (April 15 – April 30)
 - a. Review design and budget with OR of the Future Team
 - b. Determine direction
 - c. Authorize next steps

4. Design Development/Construction Documents – 8 weeks (May 1 – June 30)
 - a. Meet with surgery and perioperative representatives to finalize functional requirements
 - b. Validate Schematic Design assumptions
 - c. Finalize design and UMMS standards
 - d. Finalize equipment list
 - e. Receive budget estimates from vendors
 - f. Engage possible corporate partners
5. Review Final Design – 2 weeks (July 1 – July 15)
 - a. Review design and budget with OR of the Future Team
 - b. Validate direction
 - c. Authorize next steps
6. Bid/Award – 8 weeks (July 15 – September 15)
 - a. Develop Request for proposal for vendors
 - b. Distribute RFP to possible vendors/partners
 - c. Receive and review proposals
 - d. Award contract
7. Construction – Implement System – Estimated 3 months (September 15 – December 15) Completion date roughly corresponds with occupancy of 2nd floor OR's in Weinberg Building.

Appendix 1-C

OR of the Future - Equipped Rooms

January 30, 2003

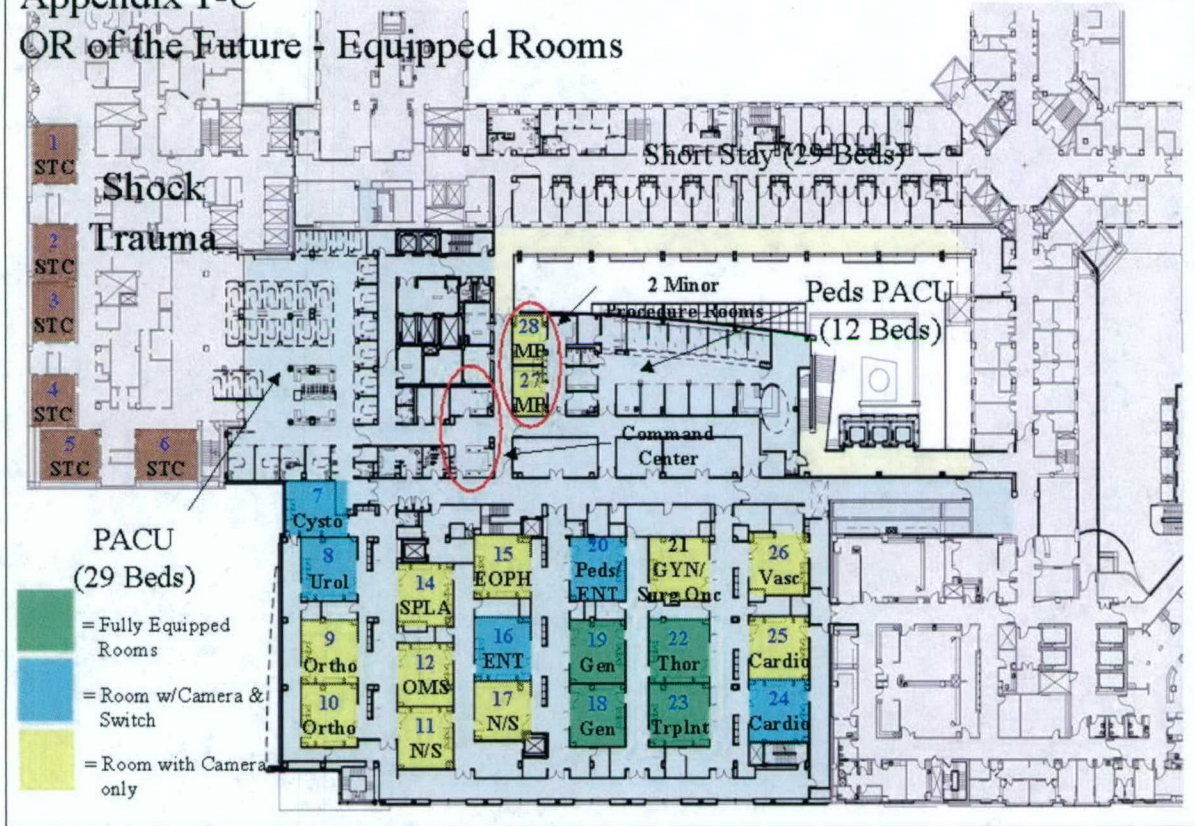

Appendix 1-C

ORF Design Documents

Page 2

Location of Flat Screen Monitors

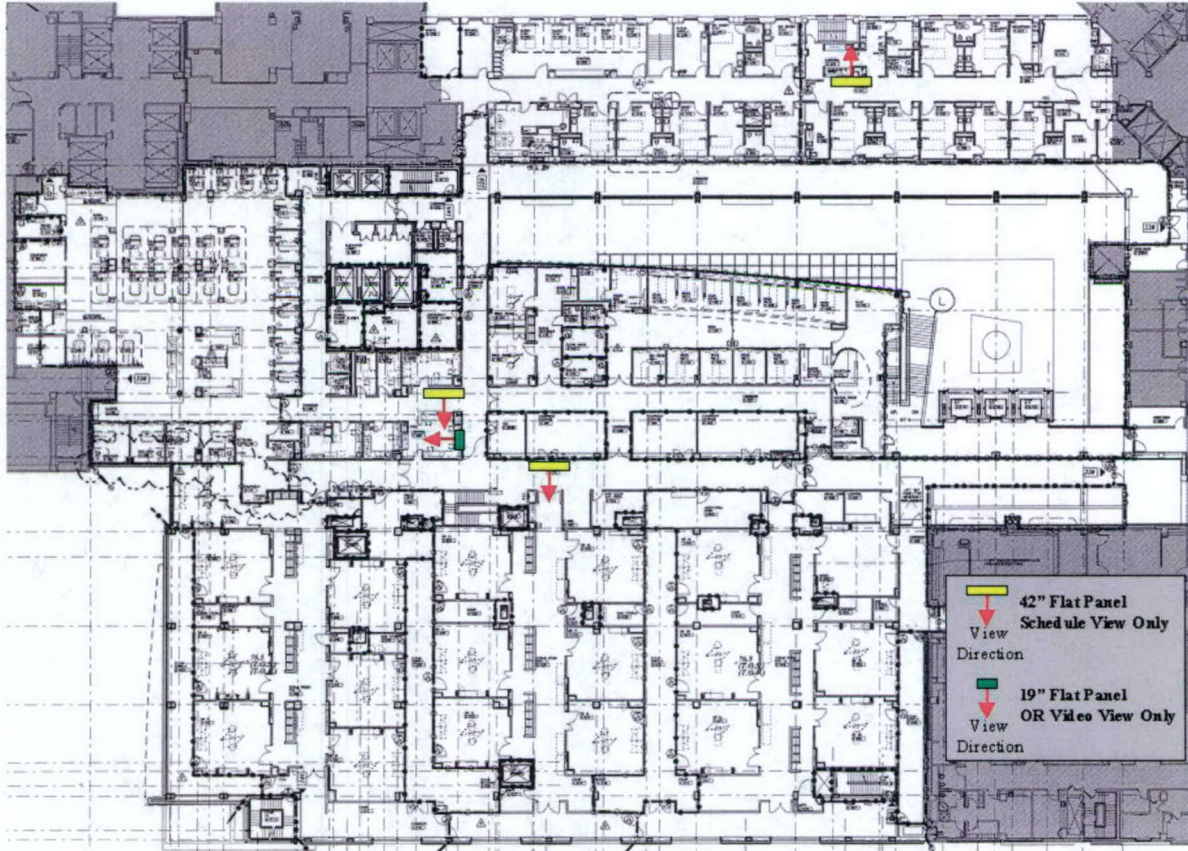

Appendix 1-C

ORF Design Documents

Page 3
Cabling Schematic

OR of the Future
Cabling Schematic - All OR's

Revised 1-30-03

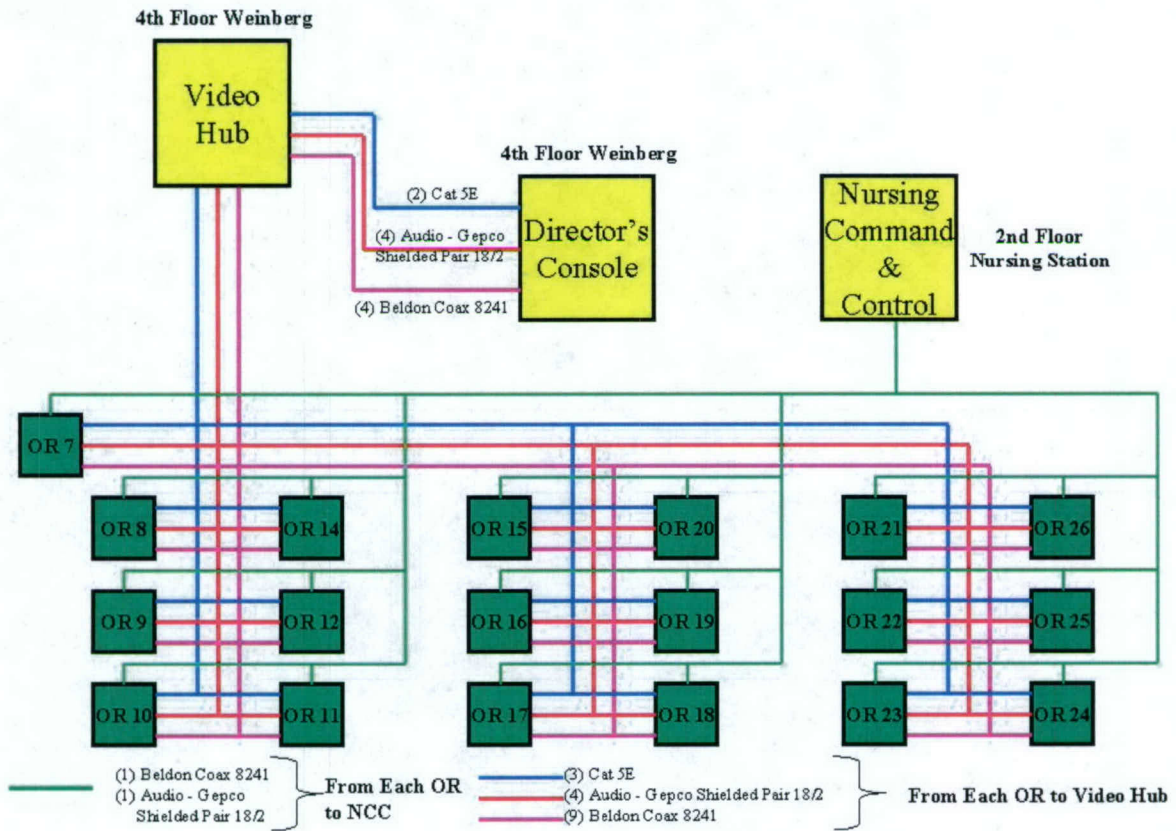

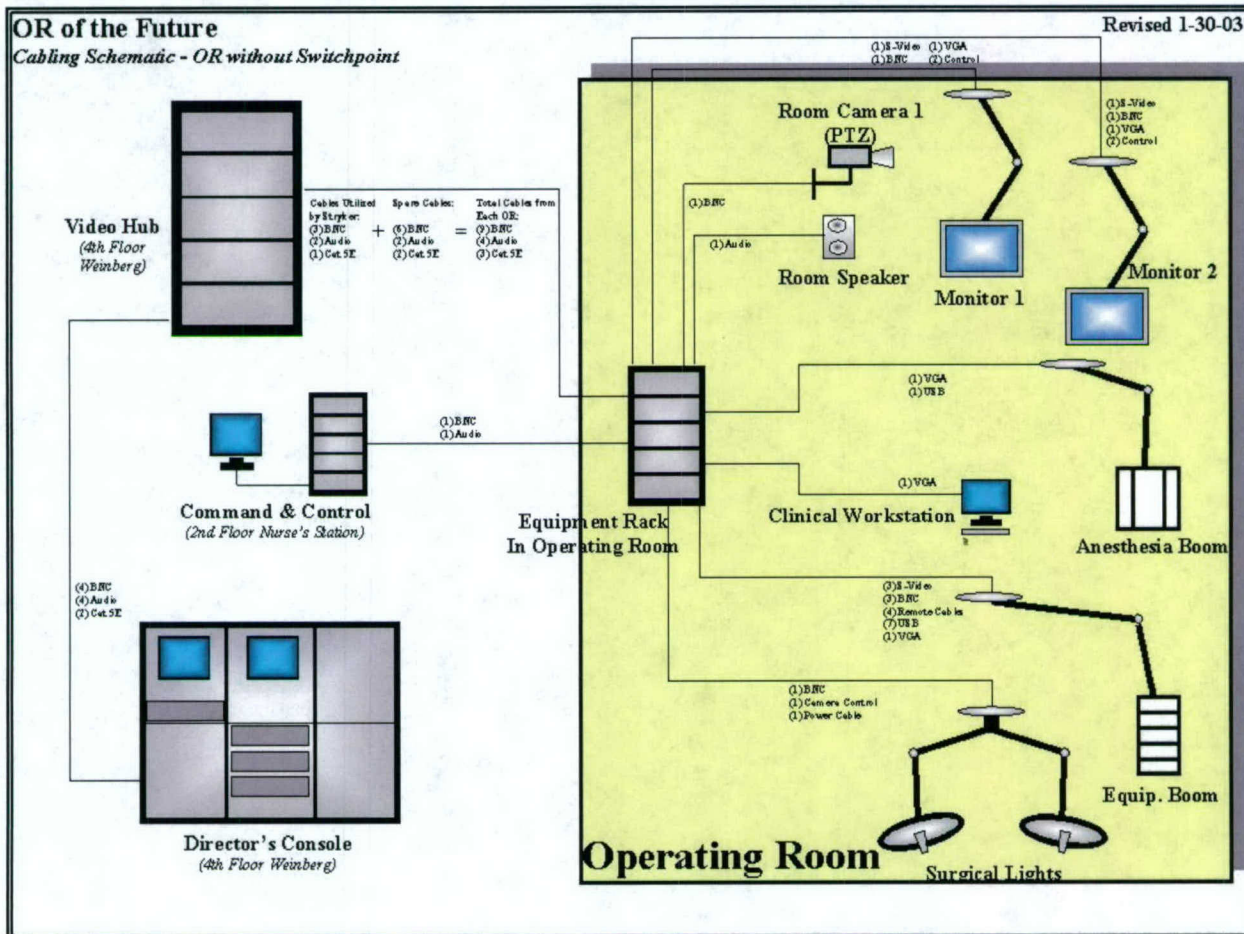

Appendix 1-D Pictures of the Operating Room of the Future

Page 1

Room Camera with
Speaker

Overhead Equipment
Booms keep floor clear

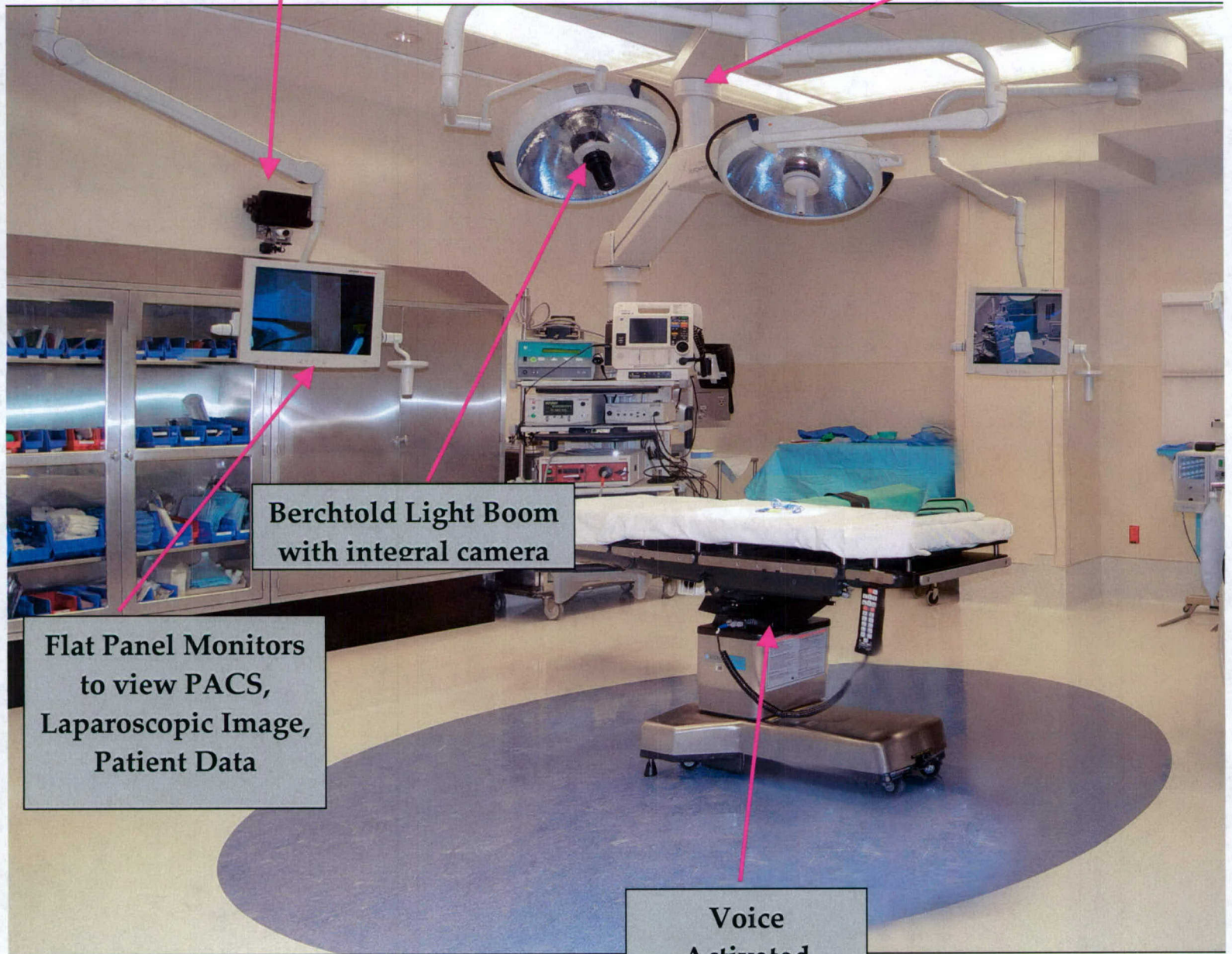

Berchtold Light Boom
with integral camera

Flat Panel Monitors
to view PACS,
Laparoscopic Image,
Patient Data

Voice
Activated

Appendix 1-D Pictures of the Operating Room of the Future

Page 2

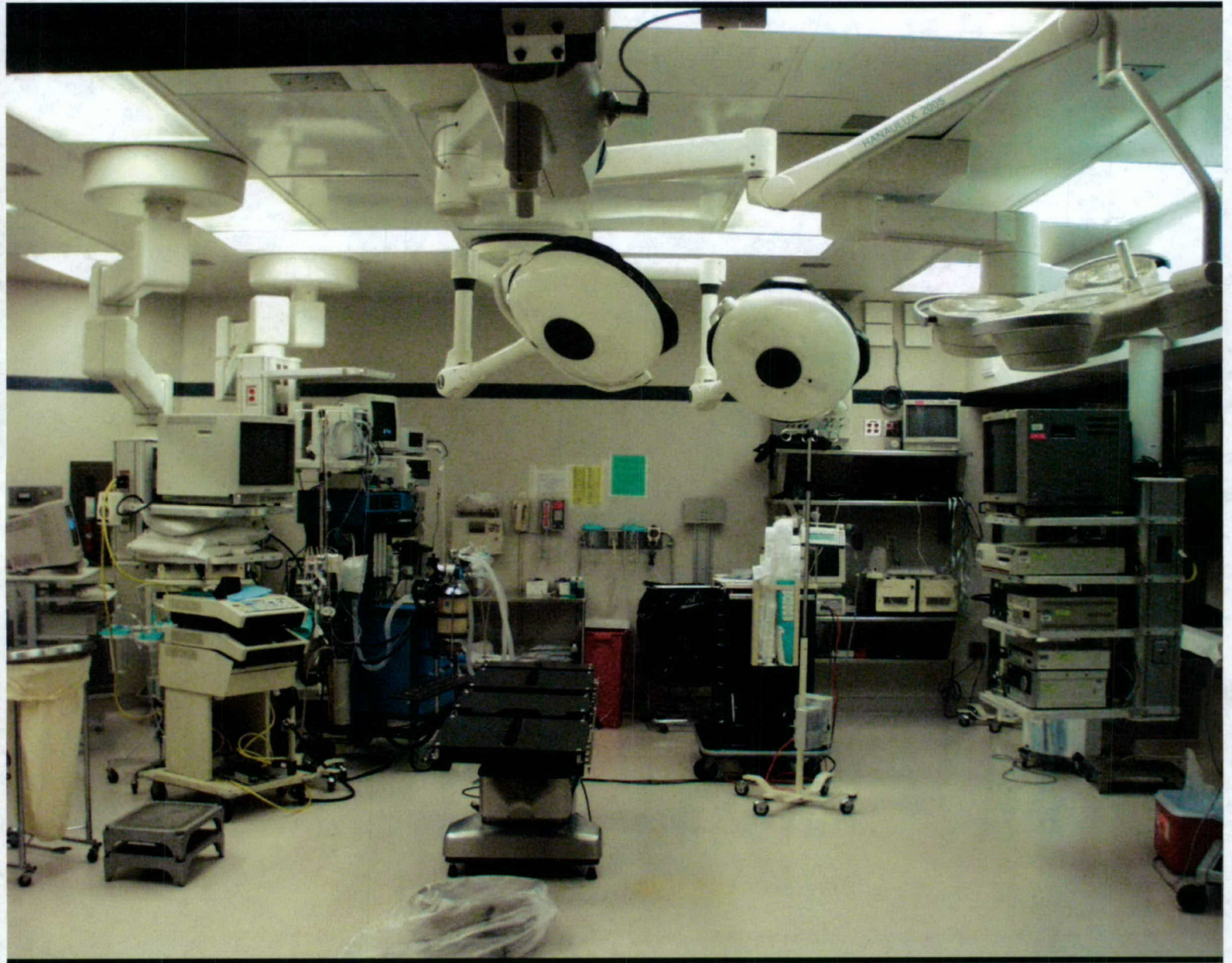

Appendix 1-D Pictures of the Operating Room of the Future

Page 3

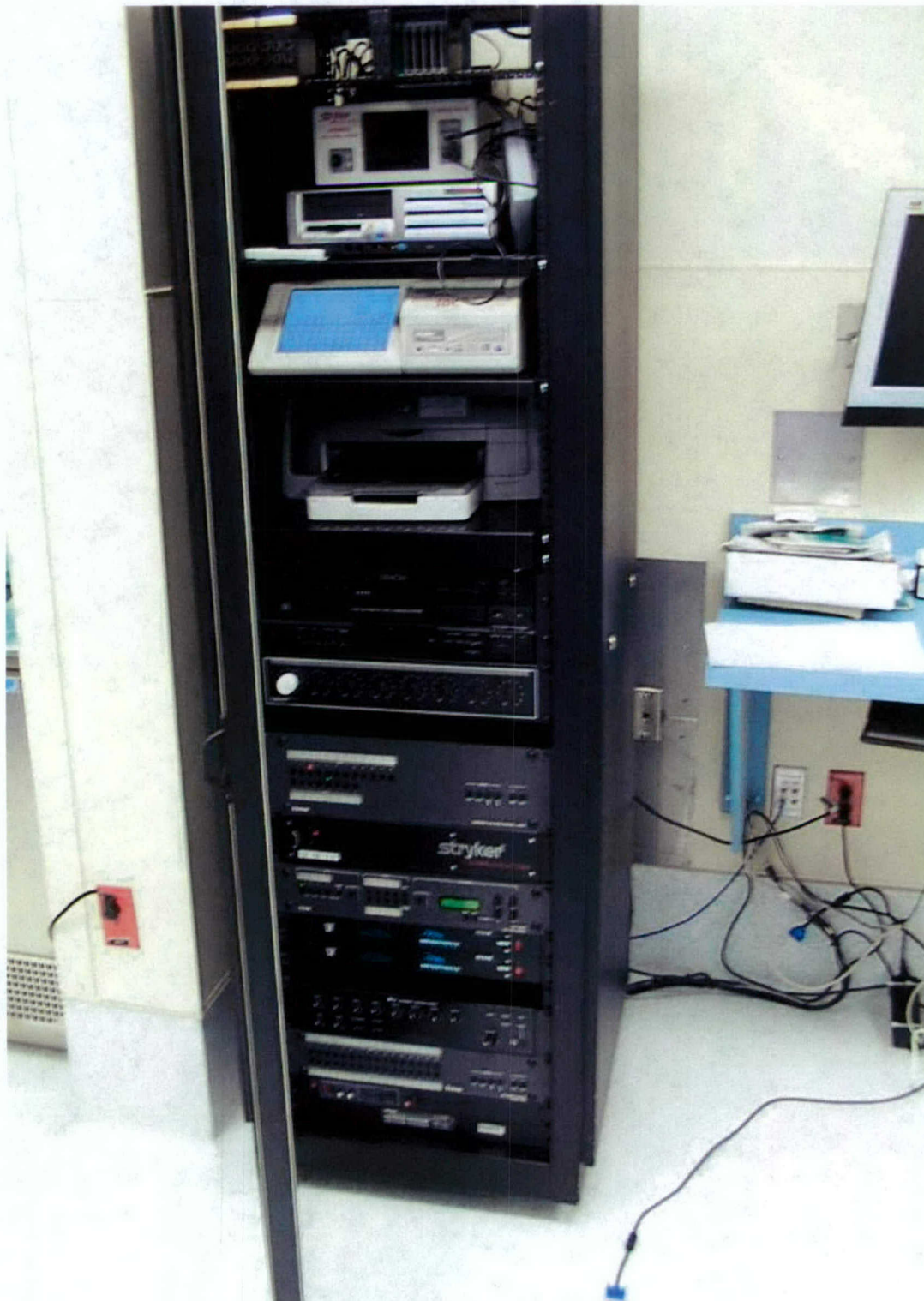

Distributed Planning and Monitoring in a Dynamic Environment: Trade-Offs of Information Access and Privacy*

Yan Xiao, Peter Hu, F. Jacob Seagull, & Colin F. Mackenzie

Human Factors & Technology Research
University of Maryland School of Medicine
Baltimore, Maryland, USA
yxiao@umaryland.edu

Jos de Visser & Peter Wieringa

Man-Machine Systems
Delft University of Technology
Delft, The Netherlands
P.A.Wieringa@WBMT.TUDELFT.NL

Abstract - *Distributed planning and monitoring relies on wide, lateral information access that may promote anticipatory behaviour, opportunistic planning and redundant checking and monitoring. The reliability of the resulting system performance is thus enhanced. However, information access control is often critical given the wide adoption of information technology. After presenting findings of several field studies related to the strategies used by distributed team members in managing information access control, we highlight how inefficiencies in information flows are exploited to achieve information access control. We then present implementation strategies for a video-based coordination platform to resolve the trade-off between information access and privacy. In particular, a role-based assignment of information access, along with mechanisms of controlling levels of information access was used to balance the potential loss of privacy with the gain in coordination efficiency.*

Keywords: Distributed planning, autonomy, information access, video based coordination.

1 Introduction

In collaborative work settings, planning is often used as a way to allow coordination of activities, despite the transient nature of plan validity in the face of constant and rapid changes [1]. High levels of uncertainty and rapid changes of events and status often lead to integration of planning, execution, monitoring of activities, and re-planning [4]. Recent studies on planning have highlighted the fact that in many domains planning activities are distributed among a number of people, often at different locations [2, 5, 8, 9].

Distributed planning and monitoring relies on wide, lateral information access that may promote anticipatory behaviour, opportunistic planning and redundant checking and monitoring. In a system described in [2] in the context of air traffic control, for example, close circuit televisions

were used to transmit real-time images of the workspaces of neighbouring workers. The intention was to increase awareness among collaborating workers and support implicit communication. With such ability to cross monitor, anticipatory behaviour is supported and systems reliability is likely to be enhanced.

Although there are clear benefits to increased awareness of activities of others, there are costs in terms of individual privacy and perceived loss of autonomy. Nardi et al. [7] described a project in which video cameras and microphones were installed in surgical operating rooms to relay audio and video to remotely situated neurophysiologists. Prior to the project neurophysiologists could access remotely patient monitoring data. With the addition of audio and video, the neurophysiologists could monitor the patient better by the supplemental audio and video information about the progress of a surgery. Additionally, neurophysiologists could schedule their tasks better by utilizing low-workload periods better. However, transmitting video and audio was found to raise serious privacy issues, such as casual conversations in operating rooms being overheard by those remotely situated. In particular, "study participants were concerned about the possibility of their work activities being broadcast to unseen and unknown observers" (p. 514).

In reporting a calendar system, Palen [6] illustrated several types of issues associated with privacy in implementing computerized groupware systems. When calendar is publicly accessible, users may be concerned about judgments made about one's use or allocation of time. Users may be further concerned about the perceived relinquishing of control of one's schedules to others. Technology that brings these concerns can also provide potential solutions, such as access control mechanisms to differentiate access rights by different people to different calendar entries. Users may adapt to the potential threat to privacy through cryptic entries, or simply by omitting appointments in the calendar systems.

Although information access control is frequently framed under the consideration of privacy, more generally, inherent tensions in the workplace (e.g., differences in opinion, judgments of priorities, and scarcity of key resources) may create resistance to increased levels of awareness. Implementation of information system often fails because of the lack of understanding of a wide range of issues in providing information access.

In this article, we first highlight the findings from several field studies related to the strategies used by distributed team members in managing information access control. In particular, we highlight how inefficiencies in information flows are exploited to achieve information access control. We then present implementation strategies for a video-based coordination platform to resolve the trade-off between information access and privacy. In particular, a role-based assignment of information access was used to justify the loss of privacy with the gain in efficient coordination methods.

2 Field Studies of Distributed Planning

To gain an understanding of distributed planning, several field studies were carried out in the context of operating room management. These studies examined how collaborators work together in managing highly fluctuating schedules and how artefacts are used.

2.1 Setting

The field studies were carried out in a six operating room (OR) suite, which was part of a busy, urban trauma center with over 6,000 patient admissions per year. A list of surgical cases was scheduled ("posted") the day before surgery and distributed to the OR suite by an on-line database. The list of cases posted was almost never the list of cases performed the next day. Often more cases were added on to the list on the day of surgery ("Add-on" cases). Emergency surgery might be performed in the OR suite for those patients who needed immediate life-saving surgery within a few hours of their admission to the trauma center.

As with many other highly complex and dynamic work environments, uncertainty arise from various sources when changes are frequently introduced. In the study setting, change was constant and unpredictable. Examples of changes affecting the planned surgery schedule include cancelled surgeries, unexpected additional surgeries (which result from both newly admitted patients as well as deterioration of previously admitted patients necessitating re-visits to an OR), multi-patient trauma situations in which demand exceeded resource supply, and any external variables impacting OR operational status (unavailable or

malfunctioning equipment, lack of supplies, and changes in staffing patterns).

As one of the tools to help manage the fluid situation, a large, dry-erase board (whiteboard) was used. The board measured 365x122cm (12 feet by 4 feet) and held magnetic materials which themselves could serve as surfaces for writing. The board was referred to as the OR board (Figure 1).

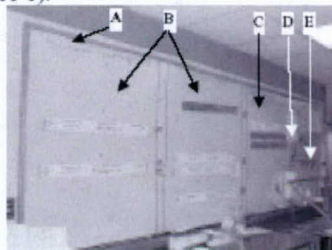

Figure 1. The OR board. Various areas of the board were used for different purposes. A: General staff information and announcements; B: magnetic case strips for all six ORs in the suite; C: Holding area for case strips, especially unscheduled add-on cases; D: Magnetic staff name tags for off-duty staff; E: Magnetic staff name tags for on-duty staff.

2.2 An observational study of artifact use

Through observation it was apparent that the OR board was used frequently by many people to collaboratively manage the ORs in terms of the case sequence, staffing requirements, equipment, and supplies. An observational study was initiated to understand how public displays were exploited to support collaborative work [9]. It was found that the OR board was exploited in a number of ways. The location of the OR board afforded the collaborating workers to share the display, often serendipitously. By sharing the board both synchronously and asynchronously, the collaborators used the board as a way to "remember" things, to visually display current status and plans, and to refer to items relevant to collaborative work. These functions of the board were found to support a number of collaborative activities, such as schedule negotiating, jointly planning for staffing and work arrangement, communicating significant changes, and calling attention to disturbances.

The findings from the observational study demonstrated the importance of widely disseminating schedule and staffing information. Collaborators, such as those working in the "upstream" section (i.e. where patients stayed before going to the OR) and "downstream" section (i.e. where patients stayed after leaving the OR), frequently visited the OR board area to get an update of what was on the OR board.

2.3 An observational study of distributed planning and monitoring

To better understand coordination processes in distributed work settings with rapidly changing resource supplies and demands, a second field study was conducted to descriptively capture the efforts by and challenges to collaborators in the management of ORs [4]. The management of ORs is an example of distributed planning, since different stakeholders have access to different information. For example, the nursing manager would know best the staff availability of nurses; the surgeon would know the planned surgery best. Although the schedule of the cases to be carried out was determined one day before, it was found that much effort was necessary to coordinate timing of events and to coordinate changes to the schedules. Since a number of stakeholders were typically involved, planning and changes to plans (re-planning) were carried out in collaborative manners.

Through observation, it was found that the planning and monitoring of ORs was distributed in several aspects. First, management tasks were distributed among different stakeholders. The generation of plans and re-planning was distributed because different care groups provided their input to the process in terms of supplies and demands. A safe and efficient surgical operation requires the contribution from several care groups to ensure adequate human and material resources. Secondly, the planning and monitoring of ORs was distributed at different locations. A successful surgical operation requires the execution and monitoring of several processes, such as preparation of the patient, the equipment, and the OR. These processes occur in different physical locations. Thirdly, the information needed for planning and monitoring of OR was distributed among different people. At any point in time, different collaborators may have access to different information. For example, a nurse may have happened to walk by a patient scheduled to go to the OR but saw that the patient was not ready for the surgery. Last but not least, the task of monitoring and ensuring the dynamic processes associated with ORs was distributed among people. To ensure the smooth flow of events in ORs, several people were found to share the task of monitoring progression of cases, and to anticipate potential obstacles to planned schedules.

Because of the distributed nature of planning in the OR management, information sharing was often cited by the study participants as the most important aspect for a safe and efficient OR suite. De Visser et al. [4] suggested two ways to support distributed planning. One was to provide mobile workers ubiquitous information access (e.g. through wireless personal digital assistants). The other was to provide electronic planning boards so that schedule information could be distributed widely.

The findings of this study highlight a key aspect of collaborative work in a dynamic environment: plans and schedules are constructed in distributed manners, continuously maintained by collective efforts, and constant monitoring efforts are needed.

2.4 An interview study of coordination in a high velocity environment

If information sharing is so critical, then why is not consistently carried out to everyone's satisfaction? One could hypothesize a number of possible reasons why information sharing is inadequate. To answer this question, we interviewed a number of stakeholders to understand the barriers to information sharing [3]. Through interview, it was found that in the studied setting, it was not unusual for staff to misinform others about their schedules and about preparatory status to obtain certain advantages. Cited examples included a situation when a surgeon might say that he is ready to operate when an OR becomes available, even if he is not yet finished with another task. Such "misinformation" is used to ensure that the room is held for the surgeon's case. Another cited example was a situation when a charge nurse might say that an OR needs disinfecting, even though the OR is ready. This "misinformation" is employed to give her staff time for a break without letting others know the real reasons.

These findings suggest that in addition to the concerns associated with privacy and autonomy, organizations often have inherent tensions among different stakeholders. Controlling access to information would be one of the methods used in such organizations to manage tensions. A direct implication of these findings would be that the deployment of information systems that may put valued, existing information access control mechanisms in jeopardy. As a result, information systems may be rejected by users.

3 A platform for coordination supporting tools

The OR suite of a trauma center (the study setting described above) was outfitted with extensive telecommunication networks as a research platform in a real, dynamic environment. There are several significant characteristics of the environment that were exploited by the research associated with the platform: the setting is highly dynamic, the tasks require the collaboration from highly specialized personnel, a large number of people (over 100) working on multiple tasks simultaneously, and the consequences of lack of coordination are high in terms of human and economic costs.

Two general research goals were pursued with the platform: (1) to experiment with innovative tools

supporting coordination, and (2) to investigate psychological and social aspects in an information technology enhanced collaborative work environment. The trade-offs between information access and privacy was an example of one such research topic. The platform allowed addition of different functional modules to change the nature of computer support and information access.

3.1 Infrastructure

In each of the six ORs, two cameras were installed to acquire video images from two ceiling mount points. All video signals were routed to a central video hub. A video server was used to provide the interface between the video hub and a secure local area network (LAN). The video server digitized video signals for processing and dissemination within the secure LAN. As part of the data communication networks, all patient monitors were connected to a separate LAN. A separate interface was developed to extract significant patient status information.

Users were provided information access through various user interfaces. The basic principle in developing user interfaces was to emulate the "First Do No Harm" oath: to ensure minimal additional efforts to the care providers and minimal undesirable disturbances to the existing work process. This principle was translated to requirements of no user training, no need for active user data-input or maintenance of data, and co-existence of the new interfaces with current interfaces.

For this paper on the issue of information access and privacy, we focus on the public display interface: the VideoBoard. The other interfaces included those on portable wireless personal digital assistants and intranet desktops. The VideoBoard was a "hybrid" whiteboard (Figure 2): networked multi-media data objects were presented in an embedded manner with regular physical objects on a whiteboard. Multi-media data objects included graphics (such as progress bars), video (such as those from ORs), and text (e.g. messages).



Figure 2. Sample layout for the embedded OR board (contrast with Figure 1). Note that video images from the cameras in the ORs are embedded with other regular OR board objects (magnets, handwritings, papers).

3.2 Mechanisms for information access control

The VideoBoard interface was used in a series of field trials to determine the trade-offs between improved

information flow and privacy. A number of mechanisms were developed to control the type and level of details of information access to OR status.

Through the studies highlighted earlier, it was learned that OR status was an important piece of information for decision making and collaboration. The VideoBoard provided a range of levels of information access to OR status, and correspondingly a range of potential threats to privacy (both that of the patients as well as the staff).

A user authentication system based on identification (ID) badges was used to control who could activate video images of a given level of details. The same authentication system was also used to track usage patterns. Since most users were familiar with the use of ID badges for accessing hospital areas, we did not anticipate any difficulties in such an interface of access control for the VideoBoard.

In terms of levels and types of information access to OR status, we provided three types of information on the VideoBoard: (1) Key OR events, as identified through an image analysis program. The key events identified included: the operating room cleaned, the patient brought in, the patient placed on the operating table, the patient covered with sterile drapes, the drapes taken down, and the patient taken out of the OR. (2) Patient monitoring status, as identified through an analysis program using patient vital signs. Two key events were automatically identified: when the patient was connected to and disconnected from patient monitors in the OR. (3) Video images. These images could be displayed at a number of levels of details with several strategies to degrade the quality of images. Details of such strategies are described in Figure 3.



Figure 3. Image display options. Top left: original video image. Top right: corresponding pixelated image. Bottom: corresponding cartoon abstraction image. Note for the cartoon abstraction image, the people working in the OR were represented as blobs in different colors. When viewed overtime, cartoon images allow identification of some of the activities.

Since video often poses significant privacy risks to both the patient and care providers, much efforts were devoted to how to exploit such a powerful information source while ensuring privacy. We anticipated great value of providing video images on the VideoBoard, which is a public display board, as many different users could potentially benefit from a better sense of situation awareness. A set of image display options were established to assist the evaluation of trade-offs between access and privacy (Figure 3). These image degrading strategies were used to provide needed information for coordination, while still providing some assurance of privacy. The options developed include:

- (1) Pixelation. An algorithm was developed to reduce the resolution to a chosen level yet maintaining the projected image size. The resulting images are "blocky" in appearance.
- (2) "Cartooning." Instead of displaying video images, we displayed abstraction of video images. Objects are displayed in filled outline forms with corresponding color. For example, the surgeons and scrub nurses are represented by dark green color, the color of their sterile overalls.

3.3 Field trials of the VideoBoard

The VideoBoard platform was used to understand the issues involved in the trade-offs between information access and privacy. A carefully planned staging process was implemented due to the sensitive nature of remote video display. The goal of the field trials was two-fold: to assess staff acceptance of remote video display, and to determine the trade offs between information access control and the amount of information transmitted. The staging process included the following elements:

- (1) Demonstration of the VideoBoard's functionalities with key personnel to solicit opinions on potential objections by the OR personnel. A mock system was established in a laboratory setting and key personnel from different care groups was invited to comment on the potential impact of deploying the VideoBoard.
- (2) A combination of group briefings and one-on-one interviews with opinion leaders. Presentations on the VideoBoard were made to the OR personnel with ample opportunities for questions and answers. Private one-on-one meetings were offered.
- (3) Ensuring clear communication to the OR personnel on what would and would not occur. For example, much of the potential reservation about remotely monitored video display was on the unknown factors with regarding of who would have access to the video images, whether

there would be transmission of audio, and whether there would be recording of images.

- (4) A series of trial-and-errors implementations of different configurations to locate the "sweet" point of the trade-offs between information access and privacy. During the trials, the question of "are the images too clear for you and for the patient" was posed to different care groups (nursing, anesthesia, surgery, and ancillary staff). The initial image quality was deliberately set to be very low and the quality was raised gradually to remove the fear of unknowns. A detailed diary was kept to document the user responses during the field trial.

The location of VideoBoard was such that only people working in the OR suite had access to the VideoBoard. These people included OR nurses (when they were on a break or on an errand), coordinators, and surgeons when they passed the OR whiteboard before entering ORs and when they came to the OR whiteboard to discuss schedules and other matters with the OR coordinators. OR coordinators were given the rights (authenticated through the ID badge reader) to display video images in any level of details they chose. There was an automatic time-out mechanism to reset the image quality. Currently the VideoBoard was the only point of displaying video images. Future plans included disseminating the OR status information (in various levels of quality) to other locations and through other platforms.

A range of user reaction was heard during the field trial. Generally, the responses could be classified into the following three types:

- (1) Totally against the idea of remote video monitoring. Although a small minority (out of about 100 OR personnel, two explicitly expressed reservations), the responses were best captured by the following quote: "I am totally against the idea [displaying video images on the OR board]. It does not matter what resolution or quality the images are. I mean, this is big brother watching." During the field trials, counter responses were voluntarily offered by other OR personnel. For example, during one trial session one member argued back, regarding image quality: "What could you identify here? Could you even tell me who is who?"
- (2) Support but having no strong feelings either way. In this type of responses, the opinions were expressed in the form of supporting the general idea of improving information access. The view on the loss of privacy was not strong because of the nature of images displayed. However, when unaltered images were presented (i.e. in native 320x240 pixel resolution), several members of the OR personnel voiced reservation on the need for such high quality of images, if the goal of improving

information access is for coordination (as opposed to observe the surgical techniques).

(3) Strongly support. In this type of responses, the opinions were stressing the value of information access. When discussing the issue of privacy, one member said: "I never understood why you [the researcher] have to be so uptight. I mean when I go to a 7-Eleven store, the camera is there and recording is going on. No one asks me for permission."

To gauge the acceptance of the VideoBoard system, we allowed the OR personnel to turn off the cameras inside the ORs. During the field trials of four weeks, the cameras were never turned off. When the VideoBoard system was turned off for maintenance or data capturing, OR personnel immediately demanded that it be turned on again.

Additionally, through interviews during the field trials, a change of attitude was detected in terms of the value of improved information access and removal of unknowns associated with the type of video images and who would be able to view what types of images. Formal evaluation through questionnaires was underway through analysis of access logs, timings of key OR events, and questionnaires.

4 Conclusions

With the advance of computing and communication technology, there is an increasing trend of deploying tools to facilitate information access. Such access can potentially improve system reliability and operational efficiency through information sharing and awareness support. If implemented properly, information technology should lower the burden of accessing information.

In some sense, remotely video access is often viewed as the most desirable form of awareness support yet at the same time the most severe intrusion of privacy. In the field trial of a coordination platform based on video, we implemented a number of options to experiment with the trade-offs between information access and privacy. The staging process was deliberate to avoid unnecessary rejection of the system. The four-week field trials had shown that it was possible to identify a satisfactory point between video-based information access and preservation of privacy.

A number of future steps were planned, including a wider range of information access to OR status to further explore the issue between information access and privacy/autonomy, which should provide further insights into the trade-offs between information access and privacy.

Acknowledgment

This research is supported by National Science Foundation (IIS-9900406 & ITR-0081868). The views expressed here are those of the authors and do not reflect the official policy or position of the authors' employers, nor the funding agency. The authors wish to thank Erik Beohm, Anadi Mahajan, & Hao Hu for their assistance in programming.

References

- [1] Bardram, J.E. Plans as situated action: an activity theory approach to workflow systems. In *Proc. ECSCW97 European Conference on Computer Supported Cooperative Work*. Kluwer Academic Publishers, 1997
- [2] Berndtsson, J. and M. Normakk. The coordinative functions of flight strips: air traffic control work revisited. *ACM GROUP99*, 101-110, 1999
- [3] Cheryl L. Plasters, F. Jacob Seagull, & Yan Xiao. Coordination Challenges in Operating-Room Management: An In-Depth Field Study. Proceedings of 2003 American Medical Informatics Association Fall Symposium. In press.
- [4] De Visser, J., Wieringa, P.A., Moss, J. and Xiao, Y. Supporting Distributed Planning in a Dynamic Environment: An Observational Study in Operating Room Management. Proceedings of 21st European Conf on Human Decision Making and Control, GIST Technical Report G2002-1, Department of Computing Science, Univ. of Glasgow, Scotland. 225-227. 2002
- [5] Garbis, C. and Y. Waern. Team coordination and communication in a rescue command staff. The role of public representations. *La Travail Humain*: 273-291, 1999
- [6] Leysia Palen. Social, individual and technological issues for groupware calendar systems. Proceedings of the SIGCHI conference on Human factors in computing systems, 17-24. 1999
- [7] Nardi, B., Kuchinsky, A., Whittaker, S., Lechner, R., & Schwartz, H. (1997). Video-as-data: Technical and social aspects of a collaborative multimedia application. In Finn, K.E., Sellen, A.J., & Wilbur, S.B. (Eds.): *Video-Mediated Communication* (pp. 487-517). Mahwah, NJ: LEA.
- [8] Roth, E. M., Malsch, N., Multer, J., & Coplen, M. (1999). Understanding how train dispatchers manage and control trains: A cognitive task analysis of a distributed team planning task. *Proceedings of Human Factors and Ergonomics Society Annual Meeting* (pp. 218-222). Santa Monica, CA: Human Factors and Ergonomic Society.
- [9] Xiao, Y., Lasome, C., Moss, J., Mackenzie, C.F. & Faraj, S. (2001) Cognitive Properties of a Whiteboard: A Case Study in a Trauma Centre. In *Proc of the Seventh European Conference on Computer-Supported Cooperative Work*, 16-20 September 2001, Bonn, Germany. Kluwer Academic Publishers, 259-278.