



**NAVAL
POSTGRADUATE
SCHOOL**

MONTEREY, CALIFORNIA

MBA PROFESSIONAL REPORT

**The Photovoltaic Power Converter:
A Technology Readiness Assessment**

**By: Steven R. Ansley, Jr., and
Lewis H. Phillips
June 2005**

**Advisors: Ron B. Tudor and
Brad R. Naegle**

Approved for public release; distribution is unlimited.

THIS PAGE INTENTIONALLY LEFT BLANK

REPORT DOCUMENTATION PAGE			<i>Form Approved OMB No. 0704-0188</i>	
Public reporting burden for this collection of information is estimated to average 1 hour per response, including the time for reviewing instruction, searching existing data sources, gathering and maintaining the data needed, and completing and reviewing the collection of information. Send comments regarding this burden estimate or any other aspect of this collection of information, including suggestions for reducing this burden, to Washington headquarters Services, Directorate for Information Operations and Reports, 1215 Jefferson Davis Highway, Suite 1204, Arlington, VA 22202-4302, and to the Office of Management and Budget, Paperwork Reduction Project (0704-0188) Washington DC 20503.				
1. AGENCY USE ONLY (Leave blank)		2. REPORT DATE June 2005	3. REPORT TYPE AND DATES COVERED MBA Professional Report	
4. TITLE AND SUBTITLE: The Photovoltaic Power Converter: A Technology Readiness Assessment			5. FUNDING NUMBERS	
6. AUTHOR(S) Steven R. Ansley Jr. and Lewis H. Phillips				
7. PERFORMING ORGANIZATION NAME(S) AND ADDRESS(ES) Naval Postgraduate School Monterey, CA 93943-5000			8. PERFORMING ORGANIZATION REPORT NUMBER	
9. SPONSORING / MONITORING AGENCY NAME(S) AND ADDRESS(ES) N/A			10. SPONSORING / MONITORING AGENCY REPORT NUMBER	
11. SUPPLEMENTARY NOTES The views expressed in this report are those of the author(s) and do not reflect the official policy or position of the Department of Defense or the U.S. Government.				
12a. DISTRIBUTION / AVAILABILITY STATEMENT Approved for public release; distribution is unlimited.			12b. DISTRIBUTION CODE	
ABSTRACT (maximum 200 words) With the DoD moving towards evolutionary acquisition and incremental development of weapons systems and soldier applications, it is important that the maturity of new technologies be properly assessed so that the probability of success, once inserted into a program, can be maximized. The purpose of this report is to examine the Photovoltaic Power Converter (PVPC) technology, developed by Aтира Technologies, as a potential Department of Defense Acquisition program/project. Specifically, the report focuses on a Technology Readiness Assessment (TRA). The report validates the PVPC technology and estimates, with 95% confidence, that the PVPC enables a solar power system to convert between 30.39% and 48.60% more solar energy into power than an identical system without the PVPC. The report also identifies and documents the required supporting information to justify a Technology Readiness Level (TRL) 5 for the PVPC. Finally, the report recommends inserting the PVPC into the DoD Acquisition System as a commercial item via horizontal technology insertion or the Advanced Concept Technology Demonstration Program.				
14. SUBJECT TERMS Photovoltaic (PV), Technology Readiness Level (TRL), Aтира, Photovoltaic Power Converter (PVPC), Commercial Item, Advanced Concept Technology Demonstration.			15. NUMBER OF PAGES 147	
			16. PRICE CODE	
17. SECURITY CLASSIFICATION OF REPORT Unclassified	18. SECURITY CLASSIFICATION OF THIS PAGE Unclassified	19. SECURITY CLASSIFICATION OF ABSTRACT Unclassified	20. LIMITATION OF ABSTRACT UL	

THIS PAGE INTENTIONALLY LEFT BLANK

Approved for public release; distribution is unlimited

**THE PHOTOVOLTAIC POWER CONVERTER: A TECHNOLOGY
READINESS ASSESSMENT**

Steven R. Ansley Jr., Major, United States Army
Lewis H. Phillips, Major, United States Army

Submitted in partial fulfillment of the requirements for the degree of

MASTER OF BUSINESS ADMINISTRATION

from the

**NAVAL POSTGRADUATE SCHOOL
June 2005**

Authors:

Steven R. Ansley Jr.

Lewis H. Phillips

Approved by:

Ron B. Tudor, Lead Advisor

Brad R. Naegle, Support Advisor

Douglas A. Brook, Dean
Graduate School of Business and Public Policy

THIS PAGE INTENTIONALLY LEFT BLANK

THE PHOTOVOLTAIC POWER CONVERTER: A TECHNOLOGY READINESS ASSESSMENT

ABSTRACT

With the DoD moving towards evolutionary acquisition and incremental development of weapons systems and soldier applications, it is important that the maturity of new technologies be properly assessed so that the probability of success, once inserted into a program, can be maximized.

The purpose of this report is to examine the Photovoltaic Power Converter (PVPC) technology, developed by Atira Technologies, as a potential Department of Defense Acquisition program/project. Specifically, the report focuses on a Technology Readiness Assessment (TRA). The report validates the PVPC technology and estimates, with 95% confidence, that the PVPC enables a solar power system to convert between 30.39% and 48.60% more solar energy into power than an identical system without the PVPC. The report also identifies and documents the required supporting information to justify a Technology Readiness Level (TRL) 5 for the PVPC. Finally, the report recommends inserting the PVPC into the DoD Acquisition System as a commercial item via horizontal technology insertion or the Advanced Concept Technology Demonstration Program.

THIS PAGE INTENTIONALLY LEFT BLANK

TABLE OF CONTENTS

I.	INTRODUCTION.....	1
	A. PREFACE.....	1
	B. RESEARCH OBJECTIVES.....	2
	C. RESEARCH QUESTIONS.....	2
	1. Primary Research Question:.....	2
	2. Secondary Research Questions:.....	3
	D. SCOPE AND ORGANIZATION.....	3
	E. METHODOLOGY.....	3
	F. EXPECTED BENEFITS.....	4
II.	BACKGROUND.....	5
	A. INTRODUCTION.....	5
	B. SOLAR ENERGY.....	5
	1. Passive Solar Power.....	6
	2. Active Solar Power.....	10
	C. ATIRA.....	16
	D. NAVAL POSTGRADUATE SCHOOL AND ATIRA.....	17
	1. Naval Postgraduate School.....	17
	2. Atira and NPS.....	18
	E. THE DEPARTMENT OF DEFENSE ACQUISITION PROCESS.....	21
	1. The Defense Acquisition Framework.....	21
	2. Overview of the Acquisition Process Focused on Technology Assessment.....	22
	F. TECHNOLOGICAL READINESS LEVELS.....	27
	1. TRL Purpose and Origin.....	27
	2. DoD Roles and Responsibilities Regarding TRA.....	28
	3. Statutory and Regulatory Information Requirements for TRAs.....	30
III.	DATA.....	31
	A. INTRODUCTION.....	31
	B. PRODUCT DESCRIPTION: CONVERTING SOLAR POWER.....	31
	1. Maximum Power Point Tracking (MPPT).....	33
	2. Switch Mode Power Conversion.....	34
	3. Relevant Range of the PVPC.....	35
	4. Physical Description.....	36
	5. Next Generation of the PVPC.....	36
	6. Summary of How It Produces Power.....	37
	C. PRODUCT TEST DATA.....	37
	1. Atira Technologies Comparison Tests.....	37
	2. NPS Field Tests.....	41
	3. Raven Designs Field Tests.....	47
	D. TECHNOLOGY READINESS LEVEL DESCRIPTIONS.....	49
	1. TRL 1: Basic Principles Observed and Reported.....	50

2.	TRL 2: Technology Concept and/or Application Formulated	50
3.	TRL 3: Analytical and Experimental Critical Function and/or Characteristic Proof of Concept	50
4.	TRL 4: Component and/or Breadboard Validation in a Laboratory Environment	51
5.	TRL 5: Component and/or Breadboard Validation in a Relevant Environment.....	51
6.	TRL 6: System/Subsystem Model or Prototype Demonstration in a Relevant Environment	52
7.	TRL 7: System Prototype Demonstration in an Operational Environment.....	52
8.	TRL 8: Actual System Completed and Qualified Through Test and Demonstration.....	53
9.	TRL 9: Actual System Proven Through Successful Mission Operations	53
E.	DOD TECHNOLOGY INSERTION MEHODS	54
1.	Commercial Item	54
2.	Advance Concept Technology Demonstration	57
IV.	ANALYSIS	61
A.	INTRODUCTION.....	61
B.	PRODUCT TEST ANALYSIS	61
1.	Atira Technologies Comparison Test.....	61
2.	NPS Field Tests	72
3.	Raven Designs Field Tests	79
4.	Summary Analysis of Quantitative Product Tests.....	80
C.	TECHNOLOGY READINESS ASSESSMENT	84
1.	TRL 1: Basic Principles Observed and Reported.....	84
2.	TRL 2: Technology Concept and/or Application Formulated	85
3.	TRL 3: Analytical and Experimental Critical Function and/or Characteristic Proof of Concept	85
4.	TRL 4: Component and/or Breadboard Validation in a Laboratory Environment	86
5.	TRL 5: Component and/or Breadboard Validation in a Relevant Environment.....	86
6.	TRL 6: System/Subsystem Model or Prototype Demonstration in a Relevant Environment	87
D.	DOD TECHNOLOGY INSERTION METHODS.....	87
1.	Commercial Item	87
2.	Advance Concept Technology Demonstration	92
V.	CONCLUSIONS AND RECOMMENDATIONS.....	93
A.	INTRODUCTION.....	93
B.	CONCLUSIONS	93
1.	Primary Research Questions:	93
2.	Secondary Research Questions:.....	94
C.	RECOMMENDATIONS.....	95

1.	Overall Recommendations for the PVPC	95
2.	Recommendations for Future Research	98
APPENDICES		101
APPENDIX A – PVPC TEST PLAN		101
APPENDIX B - SAMPLE COMMERCIAL ITEM CHECKLIST.....		121
APPENDIX C – ACRONYMS AND ABBREVIATIONS		123
LIST OF REFERENCES.....		125
INITIAL DISTRIBUTION LIST		129

THIS PAGE INTENTIONALLY LEFT BLANK

LIST OF FIGURES

Figure 1.	The Defense Acquisition Management Framework (From: DoDI 5000.2, May 12, 2003).....	22
Figure 2.	Low Light Effect on Battery Charging (After: < http://www.solengy.com/pages/whitepapers.html >, April 2005).....	32
Figure 3.	Schematic of Maximum Power Point Tracking Circuit. (From: < http://www.elecdesign.com/Articles/ArticleID/6262/6262.html >, April 2005)	34
Figure 4.	Digital Photograph of the PVPC.....	36
Figure 5.	Uni-Solar LM-3 Solar Module and Ultra-Life Polymer Battery	38
Figure 6.	Global Solar P-4 Array (From: Atira Technologies)	40
Figure 7.	NPS PVPC Field Test Configurations	42
Figure 8.	SBR Deployed on a pack and flat on the ground. (After: Raven Designs Product Brochure).....	48
Figure 9.	Defense Acquisition Framework. (After: DoDI 5000.2, May 2003).....	54
Figure 10.	LM-3 12V Test mA Comparison Graph.....	65
Figure 11.	LM-3 12V Test mW Comparison Graph.....	66
Figure 12.	LM-3 12V Test mA and mW Combined Comparison Graph.....	66
Figure 13.	LM-3 Variable Fixed Load Test Graphics.....	70
Figure 14.	Global Solar P-4 with Variable Fixed Load Graphics	71
Figure 15.	Glass Test 1: 7.4V mW Comparison Graph	73
Figure 16.	Glass Test 2: 7.4V mW Comparison Graph	74
Figure 17.	Glass Test 3 7.4V mW Comparison Graph	74
Figure 18.	Glass Test 4 3.7V mW Comparison Graph	75
Figure 19.	Flex Test with 7.4V Battery Field Test.....	77
Figure 20.	Flex Test with 3.7V Battery Field Test.....	78
Figure 21.	PP-8498/U Multi-Port Universal Battery Charger.....	96
Figure 22.	Unattended Munitions Family of Systems (After: Program Manager Unit of Action, White Paper)	98

THIS PAGE INTENTIONALLY LEFT BLANK

LIST OF TABLES

Table 1.	Statutory and Regulation Information Requirements (After: Technology Readiness Assessment Deskbook).....	30
Table 2.	LM-3 12V Test, Feb 8, 2005	39
Table 3.	LM-3 Test with Programmable Fixed Load, Feb 20, 2005	40
Table 4.	Global Solar P-4 Test with Programmable Fixed Load.....	41
Table 5.	Glass Test 1 With 7.4V Battery	43
Table 6.	Glass Test 2 With 7.4V Battery	43
Table 7.	Glass Test 3 With 7.4V Battery	44
Table 8.	Glass Test 4 With 3.7V Battery	45
Table 9.	Flexible Panel Test With 7.4V Battery	46
Table 10.	Flexible Panel Test With 3.7V Battery	47
Table 11.	LM-3 12V Test Descriptive Statistics.....	63
Table 12.	LM3 12V Test PVPC Charging Interval	65
Table 13.	LM-3 w/ Programmable Fixed Load Test Descriptive Statistics.....	68
Table 14.	LM-3 Flex Test w/ Programmable Fixed Load Excerpt.....	69
Table 15.	Global Solar P-4 Test with Programmable Fixed Load Descriptive Statistics	71
Table 16.	Glass Test 1-3 Descriptive Statistics.....	73
Table 17.	Glass Test 4 Descriptive Statistics.....	75
Table 18.	Flex Test 7.4V Battery Descriptive Statistics	76
Table 19.	Flexible Panel Test With 3.7V Battery Descriptive Statistics	78
Table 20.	Test Summary of Individual Tests	80
Table 21.	Test Summary with Outliers Excluded	82
Table 22.	t-Test: Paired Two Sample for Means	83
Table 23.	Estimated Mean Difference	83
Table 24.	DoD Regulatory Compliance Costs: Top Ten Cost Drivers.....	91
Table 25.	PP-8498/U Compatible Rechargeable Batteries and End Items They Power (After Integrated Power Management Homepage, May 2005)	97

THIS PAGE INTENTIONALLY LEFT BLANK

ACKNOWLEDGMENTS

We would like to thank our wives, Lisa and Robin, and our children for their unending support throughout our time here at the Naval Postgraduate School, and for their extraordinary understanding and patience during our rewarding but often challenging military careers. Our successes in all things are directly traceable to your love and support and the daily sacrifices you make.

In addition, we want to express our gratitude to Professors Brad Naegle and Ron Tudor for their tireless efforts to provide critical and value-added feedback to make this a more professional product. Your flexibility and guidance during this process is greatly appreciated. We would like to thank Stefan Matan, founder of Atira Technologies, who provided tremendous electrical engineering expertise and was never at a loss to explain the concepts underpinning his product in terms we could understand. Finally, we would like to extend our appreciation the U.S. Army for giving us the wonderful opportunity to attend the Naval Postgraduate School.

THIS PAGE INTENTIONALLY LEFT BLANK

I. INTRODUCTION

A. PREFACE

With the ever-increasing pace of technological evolution and the obsolescence of previous software and hardware left in its wake, the Department of Defense (DoD) needs a structured methodology to assess the technological maturity of what is being touted as “state-of-the-art” in order to determine if these technologies are ready to be incorporated into weapons systems and soldier applications. The tool the DoD uses to do this is a Technology Readiness Assessment (TRA). The ultimate product of a TRA is a finding of technological maturity, expressed as a numerical designation, which indicates the Technology Readiness Level (TRL) of the product. These assigned TRLs, from 1 through 9, tell DoD leadership and Program Managers (PM) whether the technology is ready to be moved from the Science and Technology (S&T) realm into the Acquisition realm, or if it still needs time and developmental efforts before being incorporated into an existing or new program. With the move towards evolutionary acquisition and incremental development of weapons systems and soldier applications, it is even more important that the maturity of these new technologies be properly assessed so that the probability of success with Horizontal Technology Integration (HTI) into existing programs can be maximized.

The focus of our project is the Photovoltaic Power Converter (PVPC), a device developed and patented by Atira Technologies. The device incorporates new control technology that enables a solar panel to directly power electronic devices or charge a battery even if the power output of the solar panel drops below the device’s or battery’s charging threshold. The PVPC converts the unusable, potential energy of the solar panel into usable energy that can be accepted and stored by a battery. If light hits the surface of a solar panel, potential power (Watts) is produced. However, the component characteristics (Volts X Amps = Watts) of the energy may be such that it is unusable by the connected device or battery. A 12-volt battery connected to a solar panel cannot use a 6-volt output produced by a solar panel under cloudy conditions. By converting the inherent electrical characteristics of the power produced by the solar panel, the PVPC

produces sufficient voltage to exceed the battery's charging threshold and thereby make previously unusable, below-threshold power, usable. By converting the previously unusable power produced by the panel into usable power, Atira claims the PVPC can increase the efficiency of the charging system by as much as 25 percent.¹

Although there are many benefits to using Photovoltaic (PV) technology, the primary shortcoming is the efficiency of PV systems to convert light into electricity. Currently, commercially available PV panels are on average about 10% efficient. For clarification, efficiency in this context is the percentage of absorbed light that the PV cell successfully converts into electricity. Until a technological solution is introduced that substantially increases the efficiency of PV systems, traditional power sources such as fossil fuel will continue to prevail as the preferred source of energy.

On October 31, 2003, a new company named Atira Technologies announced they had developed and patented a new device, dubbed a Photovoltaic Power Converter that could potentially address the shortfalls prevalent in the PV power industry, and enhance the benefits derived from the use of solar energy.

B. RESEARCH OBJECTIVES

The purpose of this project is to conduct a Technology Readiness Assessment (TRA) to determine the specific Technology Readiness Level (TRL) of the PVPC to determine its viability for incorporation into DoD applications. Further, we will determine and recommend the appropriate insertion point into the DoD Acquisition System for the PVPC.

C. RESEARCH QUESTIONS

1. Primary Research Question:

- Does the PVPC allow a solar power system to produce 25 percent more power than an identical system without the technology integrated?
- What is the current Technology Readiness Level of the PVPC, as defined by DoD 5000.2-R Appendix 6?

¹ Alexander Wolf, "Photovoltaic Power Conversion Technology Enhancements: Design a circuit that will track max pwr pt," (Unpublished Document, Atira Technologies, Los Gatos, CA: 2004), 2

2. Secondary Research Questions:

- What is the appropriate insertion method for the PVPC into the DoD Acquisition System?
- What organization should provide management and oversight of PVPC development?

D. SCOPE AND ORGANIZATION

The scope of this project includes: (1) a brief history of solar energy technology and applications leading up to present day capabilities; (2) a brief overview of the DoD acquisition framework/process; (3) an examination of the Technology Readiness Level (TRL) concept and definitions of each level; (4) an examination of where and how new technology can be inserted into the DoD acquisition framework/process; (5) a presentation of data on the performance characteristics of the PVPC; (6) analysis of the data and a determination of the PVPC's TRL; (7) a recommendation as to where and how the PVPC should be inserted into the DoD acquisition process; and finally (8) recommendations for further/future research.

The paper is organized into five major sections, including this chapter. The second section provides an overview of the history of solar energy, how Atira Technologies became involved with NPS, an overview of the DoD Acquisition System, and an introduction to Technology Readiness Levels. The third section contains a detailed description of the PVPC, more detail on TRLs and how to conduct a Technology Readiness Assessment (TRA), and the test data obtained on the PVPC. The fourth section provides the analysis of the data collected, and the actual TRA of the Photovoltaic Power Converter. The fifth section summarizes our findings and provides recommendations for the insertion point of the PVPC into the DoD Acquisition System, as well as suggestions for possible follow-on research.

E. METHODOLOGY

The research methodology for this project consists of:

- A comprehensive literature search of websites, magazine articles, CD-ROM systems, and internet based materials.

- A comprehensive review of government reports and documents concerning the DoD acquisition process and issues associated with the energy applications and devices.
- Analysis of the development, applications, tests and evaluations for the PVPC.
- Conducting interviews, as appropriate, with DoD and Atira personnel.

F. EXPECTED BENEFITS

This project provides the reader with a clear understanding of the capabilities of the PVPC, and its level of technological maturity. Establishing the Technology Readiness Level of the PVPC is an essential precursor to the Horizontal Technology Integration (HTI) into a subsequent increment of capability, to an already developed, effective, suitable, and fielded soldier application. One of the myriad applications to which this may lend itself is the area of rechargeable batteries. The ability to lessen both the strategic burden and tactical load of U.S. service persons by reducing the dependence on disposable batteries in a forward deployed environment without generators or normal building service power, offers great benefits both logistically and monetarily.² Additionally, should the Army or DoD decide to incorporate the PVPC into existing applications the recommended insertion point into the acquisition system may prove very beneficial.

² James Whitaker, Jason Hamilton, and Steven Sablan, *Logistical Impact Study of Photovoltaic Power Converter Technology to the United States Army and United States Marine Corps*, MBA Professional Report, Naval Postgraduate School, Monterey, CA: 2004

II. BACKGROUND

A. INTRODUCTION

Chapter II provides the background information necessary to facilitate understanding of the data, analysis and recommendations presented in Chapters III, IV, and V respectively. The chapter is organized into six primary sections beginning with the introduction. Section B provides a brief history of solar power and includes discussion of passive and active solar power. Section C presents a general history of Atira Technologies and an overview of the PVPC. Section D consists of an overview of the Naval Postgraduate School and description of the causal factors that led to the institution's involvement with Atira, and a broad overview of the DoD Acquisition Process is presented in section E. Finally, Chapter II concludes with a brief introduction to the Technology Readiness Level (TRL) concepts to include the purpose of TRLs and their origin.

B. SOLAR ENERGY

The definition for “solar” in the Meriam-Webster Online dictionary is: 3a “produced or operated by the action of the sun’s light or heat <solar energy> b: utilizing the sun’s rays especially to produce heat or electricity.”³ Experts predict that our sun will continue to burn for about the next seven billion years.⁴ Approximately 10 to 15 thousand times the world’s daily energy consumption strikes the surface of the Earth in the form of solar energy every day.⁵ With such an abundant and, in human terms, “infinite”, source of renewable energy it is no wonder that humankind has been using solar energy for thousands of years.

This section provides the reader a broad familiarization with the history of solar power from ancient through modern times. For the purposes of this report, we break the topic of solar power into two broad categories – passive and active. We introduce the reader to the differences in both categories and then give examples of each. We further

³ www.m-w.com, [October 2004]

⁴ www.encyclopedia.msn.com/encyclopedia_761562112/Sun.html, [October 2004]

⁵ www.solarserver.de/lexikon/sonnenenergie-e.html, [October 2004]

break active solar power into two main categories, those of solar thermal and photovoltaic. We then briefly discuss the benefits of photovoltaic power and current technological shortcomings in the process of converting sunlight directly into electricity.

Since the beginning, the sun has fascinated humankind, and many cultures around the globe have worshiped the sun in their religions. They understood, as we do today, that without the sun, there would be no life on Earth. Ancient people may not have understood this as well as we do today, or the scientific reasons behind this simple truth. However, they did understand that the sun was important to their lives and that they could use the life-giving light it provided them to make their lives better. There are accounts as early as fifth century BC that illustrate how the ancient Greeks used the energy from the sun.

1. Passive Solar Power

Passive solar power refers to using simple devices and architectural design to create light, a flame, or to heat things such as water or the air in your home; where the light, heat, or heated water and air are themselves the desired product. Examples of passive solar power are concave mirrors to focus the sun's rays, southern facing windows in homes, glass to trap in the heat of the sun's rays, or a black metal water container to make warm water.

a. Ancient Uses

The first written account of the use of passive solar energy is from ancient Greece. In 5th century BC the Greeks faced a severe scarcity of fuel wood, but they soon realized they could use the sun to help heat their homes.

Socrates laid out principles of passive solar design

1. main rooms should face south
2. north side of buildings should be shielded from the cold winds
3. eaves should be added to provide shade for south windows in summer

In houses that look toward the south, the sun penetrates the portico in winter, while in summer the path of the sun is right over our heads and above the roof so that there is shade.⁶

Archeological evidence dating from the 5th century shows that the Greeks actually planned whole cities using this standard house plan to make the best use of the winter sun. The city of Priene, in West Asia Minor, was designed such that all the houses were oriented with a southern exposure on an east-west/north-south street grid to allow the winter rays of the sun to come into the homes all day.⁷ This passive solar architecture in the design of homes and buildings stayed relatively unchanged for hundreds of years, until the Romans made some improvements and formally recognized its importance in the law.

With the Roman's introduction of mica or "glass" to cover the southern facing windows, in the 1st century AD, the solar heating efficiency of the "Greek solar oriented home" was exponentially increased.⁸ The Romans also recognized that the right to the sun was of key importance to all their citizens, and in the 2nd century AD they passed "domestic solar rights" laws "to ensure that no building blocked solar access to nearby houses."⁹ In 37 AD, the Romans constructed the first greenhouse and used it to grow cucumbers for Tiberius Caesar.¹⁰

In the middle ages an example of solar architecture is found in the Pueblo Indian city of Acoma, using the same classic Greek east-west running home, designed with southern facing windows.¹¹

Not everything about the use of solar energy involved the design of dwellings. In 212 BC, it is reported that Archimedes magnified sunlight using "burning mirrors" [concave mirrors that concentrated the rays of the sun] onto Roman ship sails to

⁶ <http://www.uccs.edu/~energy/courses/160lectures/solhist.htm>, [October 2004]

⁷ Perlin and Butti, www.californiasolarcenter.org/history_passive.html, [October 2004]

⁸ Ibid

⁹ <http://www.uccs.edu/~energy/courses/160lectures/solhist.htm>, [October 2004]

¹⁰ Ibid

¹¹ www.californiasolarcenter.org/history_passive.html, [October 2004]

set them on fire and repel the Roman invasion of Syracuse [Sicily].¹² Among the many other weapons of war it is reported that he created to protect Syracuse, and the mathematical principals and genius he is better remembered for, Archimedes seems to have harnessed the power in an attempt to defend his homeland. Plutarch recounts a 1st century BC example, “when the sacred flame of Delphi went out, it could only be re-lit by a “pure and unpolluted ray from the sun.”¹³ Historians believe this was done using Archimedes’ method of focusing the suns energy with concave mirrors.

b. Modern Uses

The classic Greek solar home architecture principles are still with us today and continued to evolve over time and expand their influence around the entire world. During the Renaissance, in the 16th century, this style of home became popular once again in Europe and moved to America around the 18th century.¹⁴

What was to spark the solar water heater industry in this country in the late 19th and early 20th centuries was born in 1760 when Swiss naturalist Horace de Saussure invented what was to become know as the “hot box.”

De Saussure built a rectangular box out of half-inch pine, insulated the inside, and had the top covered with glass, and had two smaller boxes placed inside. When exposed to the sun, the bottom box heated to 228 degrees F (109 degrees C) or 16 degrees F (9 degrees C) above the boiling point of water.¹⁵

By 1891 Clarence Kemp had patented a solar water heater design that “combined the old practice of exposing metal tanks to the sun [on the roof of a house] with the scientific principle of the hot box...”¹⁶ Keeping the tanks inside the glass box allowed the heat to be retained for a much longer period of time than the bare metal tanks

¹² <http://www.mcs.drexel.edu/~crrres/Archimedes/Mirrors/Tzetzes.html>, [October 2004]

¹³ Norman, http://www.eco.utexas.edu/homepages/faculty/Norman/long_extra/Student.F99/solar/car.html, [October 2004]

¹⁴ Perlin and Butti, www.californiasolarcenter.org/history_passive.html, [October 2004]

¹⁵ Perlin and Butti, http://www.californiasolarcenter.org/history_solarthermal.html, [October 2004]

¹⁶ Ibid

alone. There were 1,600 of Kemp's solar water heaters installed in Southern California homes by 1900 and by 1941 half the population of Florida used an improved version of the solar water heater.¹⁷ By the 1920s natural gas discoveries in Southern California, and the ensuing price reduction of this form of energy, effectively ended the solar water heater industry in California. Similarly, by the 1950s, cheap fossil fuel and electricity across the country made solar products relatively too expensive to continue using.¹⁸ Florida's solar water heaters went the same way as California's had two decades earlier. Countries repeated the pattern of abandoning solar power for cheaper fossil fuels as these natural resources were discovered or made readily available.

In countries with very little natural resources, extremely remote areas, or unfriendly neighbors with which to trade, solar power is a more attractive option than fossil fuels. This can be seen in the similar explosion of the use of solar water heaters in Japan, Australia, and Israel from the late 1960s through the early 1980s. In 1969, four million Japanese homes had solar water heaters, and today about 10 million Japanese heat their water with solar energy. By 1983, nearly 60 percent of Israeli homes employed solar water heaters, and today that figure is more than 90 percent.¹⁹

Today the most successful, yet little known, commercial application of passive solar heating is embodied in the solar swimming pool heater. The marriage of the pool and solar heating are a great match. The owner of the pool already owns two of the three necessary "pieces of equipment" to make it all work. The pool and its contents are the storage medium for the collected solar energy, while the pool's circulation/filter pump doubles as the engine that drives water through the solar collector. The only thing the pool owner needs to buy is the solar collector itself. In the early 1970s, American Freeman Ford developed low-cost plastic tubing to act as the solar collector.²⁰ The pool pump continuously pushes cooler pool water through the narrow, black, plastic tubing, which the sun heats, and then pushes back into the pool. The Georgia Tech Aquatic

¹⁷ Perlin and Butti, http://www.californiasolarcenter.org/history_solarthermal.html, [October 2004]

¹⁸ <http://www.uccs.edu/~energy/courses/160lectures/solhist.htm>, [October 2004]

¹⁹ Ibid

²⁰ Ibid

Center, the main site of the swimming competitions for the 1996 Summer Olympic Games, used 278 such solar collectors mounted on the center's roof.²¹

Not all uses of solar energy are passive. Since the mid 19th century, people have devised ways to use solar energy in an active capacity to do work in two general ways.

2. Active Solar Power

For this paper, we refer to active solar power as using solar energy in one of two ways to do work. The first method is called solar thermal, which uses the sun's heat, and the second, commonly known as photovoltaics, uses the energy in rays of light. Solar thermal power uses the sun to heat water, or some other liquid medium, to directly or indirectly produce vapor, which in turn drives an engine, such as a water pump, or drives a turbine to create electricity. In contrast, the term photovoltaic refers to a method by which sunlight is converted directly into electricity without any moving parts.

a. Solar Thermal Modern Uses

In 1861, French mathematics instructor Auguste Mouchout patented the first solar steam engine running on steam from solar heated water.²² By 1872, Mouchout had evolved his design into an invention that continually tracked (azimuth and altitude) and focused the sun's rays, using a conical polished metal reflector, onto a blackened copper cauldron enclosed in a glass enclosure. This apparatus would produce enough steam to run a one-half horsepower motor, which was then typically connected to a water pump.²³ By 1881, the French government, who at first was quite enthusiastic about the prospects of Mouchout's invention, "deemed the device a technical success but a practical failure" as the cost of coal drastically dropped and made this alternative source of power less attractive.²⁴

In 1878, William Adams used many of Mouchout's ideas as a basis for his own solar thermal invention. Adams used 72, 17x10 inch flat mirrors arranged in a

²¹ <http://ces.iisc.ernet.in/hpg/envis/olydoc712.html>, [October 2004]

²² Smith, http://www.solarenergy.com/info_history.html, [October 2004]

²³ Ibid

²⁴ Ibid, [October 2004]

semicircle each focused on a cauldron on a raised tower.²⁵ The entire mirror system could be moved to track the sun on a semicircular track. Adams' design, which was to become known as the Power Tower or central receiver design, was able to run a 2.5 horsepower steam engine during daylight hours for two weeks, and is the basis for many modern, large-scale, centralized solar plants.²⁶

From 1870 through 1888, Swedish born American, John Ericsson invented and continued to refine a new less complex method of focusing and tracking the sun – the parabolic trough.²⁷ Envision the polished interior of a 55-gallon drum cut in half. This configuration focuses the sun in a linear spread, as opposed to the more concentrated single point produced by the semicircular, conical reflectors. Although this focused a less concentrated beam of energy, the design provided for a simpler method to track the sun along a single axis versus the semicircle used in the Power Tower design. The parabolic trough design has become a standard for many of the largest modern solar plants “because it strikes a good engineering compromise between efficiency and ease of operation.”²⁸

In 1904, Henry Willsie designed a solar thermal solar motor that could run both day and night. The following account describes how Willsie's design worked and eventually produced up to 15 horsepower,

To store the sun's energy, Willsie built large flat-plate collectors that heated hundreds of gallons of water, which he kept warm all night in a huge insulated basin. He then submerged a series of tubes, or vaporizing pipes, inside the basin to serve as boilers. When the acting medium--Willsie preferred sulfur dioxide to Tellier's ammonia--passed through the pipes, it transformed into a high-pressure vapor, which passed to the engine, operated it, and exhausted into a condensing tube, where it cooled, returned to a liquid state, and was reused.²⁹

²⁵ Smith, http://www.solarenergy.com/info_history.html, [October 2004]

²⁶ Ibid,

²⁷ Ibid,

²⁸ Smith, 6

²⁹ Smith, 6

Like many solar entrepreneurs before him, Willsie planned to market his continuous solar power plant to the world – but with the size to power ratio so skewed, and the technical nature of dealing with sulfur dioxide, there were no interested buyers.

Undeterred, Frank Shuman working from 1906 through 1912 coupled all the knowledge and best practices of the past 50 years and basically set the standard for what would become modern solar power plants 50 plus years later. In 1912, Shuman's company and its British investors constructed a solar power plant in Cairo, Egypt. The plant utilized a tracking parabolic trough that focused solar energy on a double-paned glass encased cylinder to produce water vapor. The water vapor in turn powered a specifically designed low-pressure steam engine that generated more than 55 horsepower.³⁰ Thermal mechanical solar power was on its way – or was it? Following Archduke Ferdinand's assassination two months after the final Cairo plant trials, war soon came to Europe's colonial possessions in Africa.³¹ Because of the war, the plant was destroyed and all the engineers returned to their respective countries to perform war related tasks. Unfortunately, Shuman died before the war was over and his ideas postponed for approximately 50 years.

The combination of mature and stable fossil fuels markets, a skeptical public, and a lack of any significant crisis to precipitate massive capital investment in renewable energy sources relegated the solar power movement to a comatose state for the next 50 plus years.³² The OPEC energy crisis in the 1970s reinvigorated interest in solar power.

By the mid 1980s, modern solar engineers had rediscovered that the parabolic trough, as used by Ericsson and Shuman, offered the most economical solution when conducting a cost/benefit analysis in most locations. From the mid 1980s until 1991, when they were forced to declare bankruptcy, the Los Angeles based Luz Company operated nine parabolic trough, steam-powered electric plants, in the Mojave

³⁰ Smith, 8-9. The latter two technical innovations, that of double-paned glass and the specifically designed engine were Shuman's own.

³¹ Ibid, 9

³² Smith, http://www.solarenergy.com/info_history.html, [October 2004]

desert, producing 355 megawatts of power or 95% of the world's solar based electricity.³³ These plants were referred to as the SEGS plants, solar electric generating system, and all nine, taken over by a separate investor group, are still in operation today.

During Luz's existence, the cost of solar electricity was cut from 25 cents per kilowatthour to less than 8 cents per kilowatthour. SEGS failed economically because: (1) natural gas prices and electricity costs did not rise as expected; (2) operating and maintenance costs for the station did not decline as rapidly as had been expected; and (3) key tax incentives were expiring or uncertain.³⁴

Around the same time-frame, Solar One, a Con Edison/government team Power Tower type solar thermal plant, was also shut down due to its inability to compete with fossil fuel prices and the removal of the ten and 15 percent investment and business tax credits for independent power producers, which were subsequently restored in 1992 – one year too late. In 1996, Solar Two, using much of the equipment from Solar One, stood up as a government-industry pilot program using the same Power Tower concept using the improved conversion technology of molten salt instead of high-energy oil.³⁵

Since 1996, there have not been significant advances or adoptions in the design or uses of solar thermal power in the United States. However, more and more countries are coming on line and experimenting with and making use of solar thermal power.

b. Photovoltaic: Modern Uses

The term photovoltaic (PV) is a combination of the Greek word for light, *photos*, with a derivative of the last name of Alessandro Volta, a pioneer in the study of electricity.³⁶ A PV cell converts light from the sun directly into electricity, as opposed to using the heat from the sun, as does solar thermal power.

The direct conversion of light into electricity is explained by what was originally called the photoelectric effect, but is now also called the photovoltaic effect. In

³³ Smith, http://www.solarenergy.com/info_history.html, [October 2004]

³⁴ Dept of Energy, Solar Energy Profile, http://www.eia.doe.gov/cneaf/solar_renewables/page/solarthermal/solarprofile.pdf, [October 2004]

³⁵ Ibid, 5

³⁶ <http://www.californiasolarcenter.org/photovoltaics.html>, [October 2004]

1839, nineteen- year-old, French physicist, Edmund Bequerel first observed that certain metals would produce small electrical currents when exposed to sunlight.³⁷ The explanation of this phenomenon would have to wait until 1905 when Albert Einstein explained to the world the particle/wave duality of light and quantum physics was born. In general, Einstein found the following: light consists of particles (*photons*), the energy of which is proportional to the frequency of the light, as long as the energy of the photon exceeds the amount of energy required to keep an electron in the target medium in place, that electron will be ejected, the movement of all the ejected electrons towards a positive electrode forms an electric current.³⁸

In 1876, William Adams and his student Richard Day discovered that solid selenium exhibited the photovoltaic effect.³⁹ Although selenium was used to make photovoltaic cells, the conductivity was too low to be of any practical purpose except for using as a light meter for photographic equipment; a purpose for which it is still used today.

A major breakthrough occurred in 1953/4 when Gerald Pearson, Daryl Chapin, and Calvin Fuller, of Bell Labs, who, when experimenting with silicon, invented the first solar cells capable of converting enough solar energy into electricity to run typical electrical appliances.⁴⁰ These first silicon PV cells converted the sun's energy into electric energy at an inefficient rate of 4-6 percent. Further, it cost \$1500 per watt to produce a cell making it cost prohibitive.⁴¹ This was neither efficient nor cost effective enough for the public to use.

Throughout the 1950 and early 1960s, PV cell efficiency continued to increase while cost per watt continued to decrease. By 1958, Hoffman Electronics, the leading manufacturer of silicon solar cells had achieved 9% efficient PV cells that

³⁷ <http://encyclobeamia.solarbotics.net/articles/photovoltaic.html>, [October 2004]

³⁸ <http://www.walter-fendt.de/ph11e/photoeffect.htm>, [October 2004]

³⁹ Perlin and Butti, http://www.californiasolarcenter.org/history_pv.html, [October 2004]

⁴⁰ Perlin and Butti, http://www.californiasolarcenter.org/history_pv.html, [October 2004]

⁴¹ <http://inventors.about.com/library/inventors/blsolar2.htm>, [October 2004]

produced power at less than \$300 per watt. In 1958 and 1959, the United States launched into space the first PV-powered satellites. These systems provided satellite power for over eight years.⁴²

As methods of producing silicon and other types of PV cells improve and their efficiency increases, the cost of each watt of power produced decreases. As the cost of the cells and the power went down, more applications of PV power emerged. There are too many applications to mention, however, a few include: Off-shore oil rigs, ocean based meteorological and navigational buoys, nearly all the lighthouses in the U.S., all the road-side emergency phones in California, many railroad crossing arms and lights, and even powering entire towns. Today you can purchase PV cells with efficiency ranges of at best 10% off the Internet; however, research cells with efficiency ranges in excess of 30 percent are not available to the public.

c. Photovoltaic Benefits and Shortcomings

Because the technology we evaluate in this project is designed to work with PV cells, we limit our discussion of benefits and shortcomings to this specific area of solar energy conversion.

The benefits of using PV solar power are great. Solar energy is a continuously renewable and practically infinite source of energy, as compared to the finite amounts of fossil fuels available. PV cells convert solar energy into electricity without producing any noise. Another clear advantage of PV produced electricity over fossil and nuclear power is that there are no environmental pollutants created in the power production process. The PV process has no moving parts to breakdown, requires little maintenance, and is a completely scaleable technology. The existence of solar powered calculators and buildings illustrates the scalability of PV technology. In addition, the further you get from a traditional power source the more economical PV electricity becomes.

Although there are many benefits to using PV technology, the primary shortcoming is the efficiency of PV systems to convert light into electricity. As indicated

⁴² <http://inventors.about.com/library/inventors/blsolar2.htm>, [October 2004]

previously current systems are on average about 10% efficient. For clarification, efficiency in this context is the percentage of absorbed light that the PV cell successfully converts into electricity. Until a technological solution is introduced that substantially increases the efficiency of photovoltaic power systems, traditional power sources such as fossil fuel will continue to prevail as the preferred source of energy consumption. In early 2003 a new company named ATIRA Technologies announced they had developed a new device, dubbed a Photovoltaic Power Converter that could potentially address the shortfalls prevalent in the PV power industry and enhance the benefits derived from the use of solar energy.

C. ATIRA

This section presents ATIRA Technologies' history and a general overview of the PVPC. Stefan Matan and Marty Lettunich co-founded ATIRA Technologies in 2003. Inserted below is Mr. Matan's personal written account of the company's history to include the inspiration for the company name and its primary product.

While researching potential company names, it was clear that a technology that would have such a large impact on the environment should have a name that could coincide with our belief that our products are good for the future of the earth. It was also decided that an environmentally conscience identity is important in today's business world and that one word names are easy to remember and can say much about a company. When we came across the name Atira, the Pawnee Goddess of Mother Earth, it was obvious we had a winner, for not only the word itself but its meaning as well. Because the earth receives the sun's light, we exist and because of the power of the light, we survive and because man requires power to sustain society, we need resources that provide the power and do not deplete the earth. Power does not get lost-it is transferred from one kind to another.

The idea behind the technology began many years ago when I was a teenager. I was looking at clear glasses, which held water at a summer wedding party. Some of them were half-empty, some of them one third full, but all had some liquid left. I imagined the glasses as being batteries with some charge left and was thinking-what if it were possible to collect all the residue and useless energy and harness it? I was thinking about an electronic device called a switcher with PWM (Pulse Width Modulation). Today these are available everywhere. A couple of years ago, during the California energy crisis the idea came back again when a friend of mine asked me to create a noiseless generator to provide energy for houses. It

was a very easy task with today's technologies, but I ran into the problem that solar panels were good only when the sun was shining. There was potential that was untapped during low-light conditions. I remembered the glasses with water from that party again and decided to create a way to take that energy and make it useful. I looked for literature on the subject, but nothing was even close to my idea. So I began with the basics, creating a new mathematical model of how to organize the electrons and retrieve the energy under low light conditions. In addition to a successful model, another outcome was the ability for the device to power itself from its own energy source. I had, to put it simply, created a pump for the electrons and the solar cube was born. Obviously, I had something new on my hands. Through a mutual friend, I was introduced to David Tinsley and Marty Lettunich and ATIRA Technologies was founded.⁴³

As discussed previously the primary shortcoming is the efficiency of PV systems to convert light into electricity. The result of Mr. Matan's inspiration is a technological solution that potentially addresses this shortcoming by increasing the usable output of the photovoltaic conversion process. A detailed description and analysis of the technology and the device that incorporates it is presented in Chapters III and IV.

D. NAVAL POSTGRADUATE SCHOOL AND ATIRA

This section begins with an overview of the Naval Postgraduate School and concludes with the causal factors that led to the institutions involvement with ATIRA and the selection of the PVPCT as the topic of our MBA project.

1. Naval Postgraduate School

During the early 1900s, the Navy developed and evolved a graduate education program for the professional and educational development of its officers. Although officially established in 1909 as a school of maritime engineering at Annapolis, it would be close to forty years before Congress passed legislation that enabled the school to become a fully accredited institution and grant graduate degrees for the attending students. In 1951, Congress authorized the purchase of property to establish an

⁴³ Mr. Matan's personal account was edited for content and clarity.

independent campus for the school. As a result, the Navy purchased the Old Del Monte Hotel and grounds in Monterey and NPS became a permanent resident of California's central coast.⁴⁴

Over 50 years later, NPS is an internationally recognized high quality academic institution that provides challenging graduate level studies for approximately 1800 students. The student body is comprised of officers from all branches of service as well as Department of Defense civilians and international officers representing the services of 25 allied nations. ⁴⁵ The emphasis is on study and research programs that support the Department of Defenses' interests that are pursuant to the national military strategy of the United States.⁴⁶

2. Atira and NPS⁴⁷

The Graduate School of Business and Public Policy (BPP) is one of four schools that organizes and conducts research projects at NPS. "BPP is responsible for eight graduate academic programs and awards eight graduate degrees. The largest program is the resident defense-focused Master of Business Administration (MBA) program."⁴⁸ In 2003, Professor Ron B. Tudor, a lecturer for the Graduate School of Business and Public Policy, was working on a project involving members of the private sector when Marty Lettunich, CEO and co-founder of ATIRA, approached him. Mr. Lettunich informed Professor Tudor of an exciting new technology developed and patented by ATIRA. Mr. Lettunich provided a general description of the Photo Voltaic Power Converter and suggested that the product potentially had multiple defense related applications. He asked Professor Tudor if NPS would be interested in becoming involved in research and development of the product, specifically to identify potential military applications. Although intrigued by the concept of PVPCT and potential applications, Professor Tudor

⁴⁴ "A Short History of The Naval Postgraduate School", <http://www.nps.edu/aboutnps/navigation/heritage.html>, [October 2004]

⁴⁵ "A Short History of The Naval Postgraduate School", <http://www.nps.edu/aboutnps/navigation/heritage.html>, [October 2004]

⁴⁶ "NPS At a Glance", <http://www.nps.edu/aboutnps/navigation/descNPS.html>, [25 October 2004]

⁴⁷ The information provided in this section was obtained from an interview conducted by the authors with Professor Ron Tudor, 13 October 2004, GSBPP, NPS, Monterey, Ca.

⁴⁸ "Programs", 18 October 2004, <<http://www.nps.navy.mil/gsbpp/programs.htm>>, [25 October 2004]

remained skeptical of the validity of the technical application and design. Tudor informed Lettunich that before NPS would apply institutional resources to research ATIRA's new product, an organization within the Department of Defense must sponsor the research and an independent validation of the PVPCT technological conducted.

Ultimately, Lieutenant General (LTG) J.R. Vines, Commander of the U.S. Army 18th Airborne Corps, contacted Professor Tudor via email, expressing interest in potential military applications of PVPCT and a willingness to sponsor the research. Subsequent correspondence between NPS and LTG Vines resulted in a NPS research initiation proposal approved by LTG Vines and endorsed by M.A. Gallagher, the Program Manager for Expeditionary Power Systems, Marine Corps Systems Command. The proposal specified Low-Light Solar Charging as the focus of the research and designated a period of performance of 1 May 2004 through 30 April 2006 at an estimated cost of \$300,000.

After receiving LTG Vines initial email, Professor Tudor became intrigued by the level of interest within the Army and by the novelty of the product. While awaiting the signature approval from LTG Vines; Professor Tudor decided to expedite the initial validation of the technology. He contacted Dr. Sherif Michael, a Professor of the School of Engineering and Applied Sciences at NPS and renowned as an authority in photovoltaics, and requested he review the PVPCT. Skeptical that the PVPCT could in fact perform as proclaimed and the technology valid, Dr. Michaels agreed to a demonstration. However, following the demonstration, Dr. Michaels reversed his position and indicated that the technology was likely valid and if further testing proved favorable, its potential applications could revolutionize the solar power industry.

With both of his requirements essentially met, Professor Tudor proposed a formal agreement between NPS and ATIRA in the form of a Cooperative Research and Development Agreement (CRADA). Provided below is a detailed definition of a Cooperative Research and Development Agreement and its purpose.

A Cooperative Research and Development Agreement (CRADA) is a written agreement between a private company and a government agency to work together on a project. Created as a result of the Stevenson-Wydler

Technology Innovation Act of 1980, as amended by the Federal Technology Transfer Act of 1986, a CRADA allows the Federal government and non-Federal partners to optimize their resources, share technical expertise in a protected environment, share intellectual property emerging from the effort, and speed the commercialization of federally developed technology. A CRADA is an excellent technology transfer tool. It can: Provide incentives that help speed the commercialization of federally-developed technology. Protect any proprietary information brought to the CRADA effort by the partner. Allow all parties to the CRADA to keep research results emerging from the CRADA confidential and free from disclosure through the Freedom of Information Act for up to 5 years. Allow the government and the partner to share patents and patent licenses. Permit one partner to retain exclusive rights to a patent or patent license.⁴⁹

The proposed CRADA between NPS and ATIRA establishes roles and responsibilities of each organization, referred to in the CRADA as collaborators. Under the proposed CRADA, NPS requested \$400,000 from ATIRA to conduct research and testing of ATIRA's technology and assist ATIRA to transfer the technology into products that can be used by the Department of Defense in both tactical and operational environments.⁵⁰

With a CRADA in the works and armed with a sponsor and initial validation for the PVPCT, Professor Tudor began soliciting students interested in conducting research as an MBA project. Students attending the NPS GSBPP are required to complete an MBA project as a prerequisite to graduation. The purpose of the NPS MBA project is to have students apply academic theory to solve DOD problems. After meeting with multiple students, Professor Tudor approved two primary topics for research. The abstracts for both projects are below for review:

Logistical Impact Study of Photovoltaic Power Converter Technology To The
United States Army And The United States Marine Corps

The purpose of this MBA Project was to analyze the logistical and fiscal impact of replacing selected disposable batteries with rechargeable batteries and photovoltaic power converter chargers within army and

⁴⁹ www.usgs.gov/tech-transfer/what-crada.html

⁵⁰ Navy Cooperative Research Agreement, NPS and ATIRA, Low-Light Solar Charger, Draft, page 7

Marine Corps infantry battalions. This project was conducted with the sponsorship and assistance of XVIII Airborne Corps, Marine Corps Systems Command, Fleet Numerical, and the Defense Advanced Research Projects Agency. The goal of this project was to identify how this new technology could be incorporated into current combat gear and what impact such an incorporation of the technology would have in decreasing the infantryman's combat load, reducing expenditures on batteries, and relieving the overall logistical burden for the subject services.

The Photovoltaic Power Converter: A Technology Readiness Assessment

The purpose of this project is to examine the Photo Voltaic Power Converter Technology, developed and patented by Atira, as a potential Department of Defense Acquisition program/project. Specifically the project will focus on the Technology Readiness Level (TRL), Critical Operational Issues (COI), and Key Performance Parameters (KPP). The project will evaluate and identify the current Technology Readiness Level (TRL) of the PVPC and develop recommended KPPs and COIs for the system. Additionally we will recommend the appropriate insertion point of the PVPC into the DoD acquisition process.

E. THE DEPARTMENT OF DEFENSE ACQUISITION PROCESS

In order to answer our primary, and most of our secondary research questions, specifically, "what is the appropriate insertion point for the PVPC into the DoD Acquisition System," an understanding of the Defense Acquisition System is required. The following section provides the reader with a brief overview of this system.

The Defense Acquisition System manages the nation's investments in technologies, programs, and product support necessary to achieve the National Security Strategy and support the United States Armed Forces by acquiring quality products that satisfy the user's needs for measurable improvements to mission capability and operational support, in a timely manner, and at a fair and reasonable price.⁵¹

1. The Defense Acquisition Framework

The DoD uses a management process based on centralized policies and principles, known as the Defense Acquisition Management Framework, to allow for the decentralized and streamlined execution of acquisition activities among and within the armed services. The vast majority of these centralized policies and principles are

⁵¹ Department of Defense Directive (DoDD) 5000.1, page 2.

contained in two publications, both of which were updated on 12 May 2003, the Department of Defense Directive 5000.1 (DoDD 5000.1) and the Department of Defense Instruction 5000.2 (DoDI 5000.2). This framework is intended to provide flexibility, responsiveness, and encourage innovation when developing a material solution to fit the user's requirement, while also maintaining strict emphasis on discipline and accountability. A graphic depiction of the Framework is shown in the figure below.

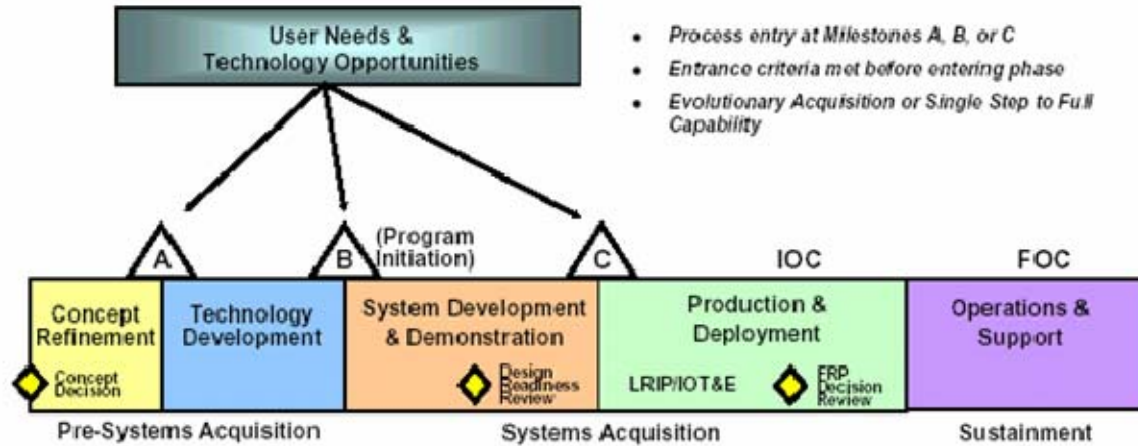

Figure 1. The Defense Acquisition Management Framework (From: DoDI 5000.2, May 12, 2003)

2. Overview of the Acquisition Process Focused on Technology Assessment⁵²

A program to acquire a new system or capability is normally established in response to a recognized and validated user need, but it can also be established to exploit a technological opportunity that might result in a new military capability, a reduced cost, or other benefit. Within this framework, each program can be structured to achieve the best balance of cost, schedule, and performance. The process of exploiting new technology and integrating it into an existing program is known as Horizontal Technology Insertion (HTI). The PVPC represents such a technological opportunity. It has the ability to provide a new and added capability to current battery charging systems, reduce overall costs, and lessen the logistical burden of disposable battery use by allowing for

⁵² This section is taken, with minor modifications, in its entirety from the DoD Technology Readiness Assessment (TRA) Deskbook, September 2003, section 1.4.

the expanded use of rechargeable batteries within the DoD as demonstrated in our colleagues' above mentioned MBA project.

The following description of the acquisition system is limited to the elements that impact technology selection, development, and use in defense system acquisition. DoDI 5000.2 contains a far more complete description of the acquisition system.

Consistent with a joint integrated architecture,⁵³ the Under Secretary of Defense for Acquisition, Technology, and Logistics (USD(AT&L)) leads “the development of integrated plans . . .”⁵⁴ With advice from the Chairman of the Joint Chiefs of Staff (CJCS) and the Joint Requirements Oversight Council (JROC), multiple DoD communities “assist in formulating broad, time phased, operational goals, and [in] describing requisite capabilities in [an] Initial Capabilities Document (ICD).”⁵⁵ After analysis of potential system concepts, the ICD describes a selected concept based on “robust analyses that consider affordability, technology maturity, and responsiveness.”⁵⁶

The ICD and a plan for an Analysis of Alternatives (AoA) are presented to the Milestone Decision Authority (MDA) for approval. Approval initiates the Concept Refinement phase of the process as shown in the previous figure. During Concept Refinement, the selected concept is refined, and alternative technologies (not alternative concepts) are analyzed. This analysis includes consideration of the maturity of the alternative technologies. Whenever the system concept requires technologies that are promising but still unproven, the Component includes a project for maturing the technology in a Technology Development Strategy (TDS). Among other things, the TDS describes how the program will be divided into technology spirals and development

⁵³ The joint integrated architectures are developed collaboratively by the USD(AT&L), the ASD(NII) (formerly ASD(C3I)), the Joint Staff, the Military Departments, the Defense Agencies, Combatant Commanders, and other appropriate DoD Components. See DoDI 5000.2, paragraph 3.2.1.1.

⁵⁴ DoDI 5000.2, paragraph 3.2.2.

⁵⁵ Ibid, paragraph 3.4.1.

⁵⁶ Ibid.

increments. The program enters Technology Development (TD) at Milestone A when the MDA approves the TDS. Generally speaking, the program is not yet considered an “acquisition program.”⁵⁷

During TD, the technologies required to design and build the system are pursued so that they will be sufficiently mature by Milestone B. TD is a continuous technology discovery and development process that reflects a close collaboration between the user and the system developer and between the system developer and the technology developers.⁵⁸ This phase reduces technology risk and determines which technologies are mature and should be integrated into a system. For an evolutionary program, this selection of mature technologies applies to the next increment that will have a Milestone B. TD continues for subsequent increments, each of which has its own Milestone B.

A Technology Readiness Assessment (TRA) must be conducted before each Milestone B (and before each Milestone C). One of the criteria for exiting TD is that the technology has been demonstrated in a relevant environment.⁵⁹ TD demonstrations are used to substantiate technology maturity. These demonstrations should use prototypes or engineering development models (EDMs) at the subsystem level. That is, these items, after detailed design, should be suitable for integration into the system.

During the TD phase, the Joint Staff produces a Capability Development Document (CDD) that builds on the ICD and supports the initiation of an acquisition program. The CDD provides the detailed operational performance parameters necessary to design the proposed system.

The technologies chosen for the system must provide an affordable increment of capability.⁶⁰ This requires that the chosen technologies are producible at an acceptable cost and production rate. While not explicit in DoDI 5000.2, this implies that

⁵⁷ Shipbuilding acquisition programs can be initiated at Milestone A. See DoDI 5000.2, paragraph 3.6.3.

⁵⁸ The system developer and the technology developers may formalize their association with Technology Transition Agreements. Appendix J [of the TRA Handbook] contains an example template for an agreement.

⁵⁹ DoDI 5000.2, paragraph 3.6.7.

⁶⁰ DoDI 5000.2, paragraph 3.6.7.

manufacturability and producibility have been considered in the selection of technologies and the assessment of their maturity level.

Milestone B authorizes a program or increment of a program to enter System Development and Demonstration (SDD). SDD consists of two major efforts (System Integration and System Demonstration) and a mid-phase Design Readiness Review (DRR). System Integration is the system design phase during which the chosen technologies and subsystems are integrated into a detailed system design, and the manufacturing processes are developed. This effort typically includes demonstration of prototype articles or EDMs that result from integration of some or all of the subsystems. The DRR marks the transition to System Demonstration. During System Demonstration, prototypes are demonstrated in the intended environment, showing that the system can meet approved requirements.⁶¹ This phase must also establish that no significant manufacturing risk exists and that industrial capabilities are reasonably available.

A new or revised TRA is required before Milestone C. This TRA should reflect the resolution of any technology deficiencies that arose during SDD and should establish that all critical manufacturing technologies are mature.

Milestone C follows SDD and authorizes Low Rate Initial Production (LRIP). LRIP completes manufacturing development to ensure efficient manufacturing capability and produces production-representative articles for Initial Operational Test and Evaluation (IOT&E).⁶²

Approval for Full Rate Production (FRP) depends on demonstrating that critical manufacturing processes are under control and that statistical process control data are being collected.

⁶¹ After DRR, a Capability Production Document (CPD) is finalized by the Joint Staff, and it is validated and approved before Milestone C. Key Performance Parameters (KPPs) from the CPD are inserted verbatim into the acquisition strategy and the Acquisition Program Baseline (APB). See Chairman of the Joint Chiefs of Staff Manual (CJCSM) 3170.01, Operation of the Joint Capabilities Integration and Development System, dated 24 June 2003, Enclosure F paragraphs 1. and 2, (<http://www.teao.saic.com/jfcom/ier/documents/m317001.pdf>).

⁶² From DoDI 5000.2, 3.8.3.4. “LRIP is not applicable to AISs or software-intensive systems with no developmental hardware; however a limited deployment phase may be applicable. Software shall have demonstrated the maturity level required in the CPD before deploying it to the operational environment.” An AIS is an automated information system.

The framework just described can be tailored to a specific acquisition program structure. For example, the program does not have to start at Concept Refinement. It can start at any point consistent with phase-specific entrance criteria and statutory requirements. If it starts at or beyond Milestone B, an associated TRA is conducted to ensure that the technology is ready for the upcoming phase of acquisition. Normally, a program is not considered an “*acquisition program*” until it has passed Milestone B.

DoDI 5000.2 establishes evolutionary development as the strategy DoD prefers:

3.3.2. The approaches to achieve evolutionary acquisition require collaboration between the user, tester, and developer. They include:

3.3.2.1. Spiral Development. In this process, a desired capability is identified, but the end-state requirements are not known at program initiation. Those requirements are refined through demonstration and risk management; there is continuous user feedback; and each increment provides the user the best possible capability. The requirements for future increments depend on feedback from users and technology maturation.

3.3.2.2. Incremental Development. In this process, a desired capability is identified, an end-state requirement is known, and that requirement is met over time by developing several increments, each dependent on available mature technology.

For hardware systems, evolutionary development normally uses incremental development. Each successive design unit is called an increment (Increment 1, Increment 2, and so forth). To ensure that the technology is mature, a TRA is required for each increment before the program has a Milestone B or Milestone C review for that increment.⁶³

Software is normally developed using the spiral development process. This is an iterative, cyclical process of build-test-fix-test-deploy. Each release builds on the lessons of the previous release. There can be several releases during the acquisition and deployment of a system or system increment. In the TRA process, software is considered an integral part of the system or subsystem in which it operates. Therefore,

⁶³ DoDI 5000.2, paragraph 3.7.2.4 and Table E3.T2.

demonstration of a technology at the subsystem or system level must include demonstration of the associated software. The Army, for its use, has defined TRLs for software.⁶⁴

F. TECHNOLOGICAL READINESS LEVELS

This section provides a general background on the Technology Readiness Level (TRL) concept and includes the purpose and origin of TRLs, Department of Defense roles and responsibilities regarding Technology Readiness Assessments (TRAs), and Statutory and regulatory information requirements. Chapter III presents a more detailed description of each TRL level and the TRA process.

1. TRL Purpose and Origin

Science is the “observation, identification, description, and experimental investigation and theoretical explanation of phenomenon”⁶⁵ and technology is “the application of science”.⁶⁶ Thus, it is the application of science that is often the driving force behind the new systems and equipment developed by DoD for use by the armed forces. Consequently, the maturity level of the technology can directly impact program success. Technology Readiness Levels are a consistent measurement to categorize the maturity level of a program’s key technologies and provide a common language or reference to the science and technology community within the DoD Acquisition process. Further, the definitions for each readiness level are applicable across the broad spectrum of technologies in both hardware and software.

The conception of a common metric for technology maturity was born in the National Aeronautical and Space Administration in the mid 1980’s. NASA developed seven levels beginning with level one, the basic Principle Observed and Reported, and ending with level seven, System Adequacy Validated in Space. The Air Force began to incorporate the TRL concept into its programs in the early 1990s and then on April 6, 1995, John C. Mankins, a NASA employee, published a white paper clearly defining nine

⁶⁴ The Army’s TRL for Software can be found in Appendix G of the TRA Handbook.

⁶⁵ The American Heritage Dictionary of the English Language, Fourth Edition, Houghton Mifflin Company, 2002

⁶⁶ Ibid

different technology readiness levels.⁶⁷ The next key publication on TRLs was GAO Report 99-162, released in 1999. The GAO conducted extensive research of government and commercial programs and their incorporation of 23 new technologies into a variety of products and weapons systems. The report identified a direct correlation between the maturity level of critical technologies integrated and program success, and recommended that the DoD adopt a stringent TRL maturity assessment program. In 2001, the Under Secretary of Defense for Science and Technology formally adopted GAO recommendations by issuing a memorandum endorsing use of TRL metrics for new programs. Finally, in 2003, DoD provided comprehensive guidance for the acquisition community by publishing the DoD Technology Readiness Assessment Deskbook.⁶⁸

2. DoD Roles and Responsibilities Regarding TRA

In addition to providing definitions for TRLs and a process to conduct a Technology Readiness Assessment, the DoD Technology Readiness Assessment Deskbook documents the roles and responsibilities of service components, DoD offices, and agencies to conduct the TRAs suggested by DODD 5000.1, DODI 5000.2 and *Interim Guidance*. The summary below lists these roles and responsibilities.⁶⁹

a. Secretary of Defense

- Reports to Congress on the implementation of DoD policy regarding maturity at the initiation of MDAPs IAW Sec. 804 of the NDAA for fiscal Year 2002 Conference Report

b. Deputy Under Secretary of Defense for Science and Technology (DUSD(S&T))

- Provides oversight of during technology development of a program
- Oversight and evaluation responsibilities for the TRA
- Reviews component TRAs and concurs or conducts independent TRA
- Submits findings to OIPT and the DAB
- Recommends if technology is mature enough at each milestone review

⁶⁷ John C. Mankins, *Technology Readiness Levels*, White Paper, NASA, April 6, 1995.

⁶⁸ Wikipedia, the free encyclopedia, http://en.wikipedia.org/wiki/Technology_Readiness_Level, [October 2004]

⁶⁹ Appendix C presents, in its entirety, appendix B from the TRA Deskbook which includes from DoDD 5000.1, DoDI 5000.2, and the Interim Guidebook extracts that establish or suggest TRA roles and responsibilities.

- Prepares Submits DoD technology implementation and technology readiness reports IAW Sec.804 of the NDAA for fiscal year 2002 Conference Report

c. Component Acquisition Executive (CAE)

- Approving authority for ACAT I and ACAT IA TRAs
- Submits action copy of TRA to DUSD(S&T) with a TRL assessment for each critical technology for ACAT ID and ACAT IAM programs
- Reports through the Component Secretary to the USD(AT&L)

d. Component Science and Technology (S&T) Executive

- Develops non-commercial technologies that the component needs for to meet future operational requirements
- Advises PMs regarding status and applicability of new technologies
- Provides resources and development support during Technological Development phase before Milestone B
- Directs the component's TRAs and establishes process
- Signs TRAs and accepts responsibility for its accuracy for ACAT ID and ACAT IAM programs
- Reports to CAE

e. Program Manager:

- Guides development during technological development and prepares for Milestone B
- Submits memorandum to DUSD(S&T) and Component S&T describing process the PM will use to identify critical technologies for the program
- Identifies critical technologies for the program and details the function of each technology and status of the technologies development
- Requests Milestone B and C reviews and schedules submission of critical technologies
- Provide program updates to the Defense Acquisition Board on technology maturity, risk management, affordability, technological protection and rapid insertion.
- Address any interoperability and supportability requirements linked to other systems
- Form and lead an IPT for the program
- Coordinates TRA activities with DUSD(S&T) and Component S&T as appropriate
- Reports to PEO who in return reports to the CAE

3. Statutory and Regulatory Information Requirements for TRAs

As previously discussed, TRAs of critical technologies for each program are required at the major milestone reviews. The Tables below present the information required, the applicable statute or regulation, and when it is required.

Table 1. Statutory and Regulation Information Requirements (After: Technology Readiness Assessment Deskbook)

Statutory Information Requirements		
Information Required	Applicable Statute	When Required
Consideration of Technology Issues	10 U.S.C. 2364, reference (q)	Milestone (MS) A, B, and C
Technology Development Strategy (TDS)	Sec. 803, Pub.L. 107-314, reference (an)	MS A, B, and C
Regulatory Information Requirements		
Information Required	Regulatory Source	When Required
Technology Readiness Assesment	DoDI 5000.2, dated May 12, 2003	Program Initiation for Ships Preliminary Assessment MS B and C
Independent Technology Assesment (ACAT ID only) (If required by DUSD(S&T))	DoDI 5000.2, dated May 12, 2003	MS B and C
Commmand, Control, Communications, Computers, and Inteilligence Support Plan (C4ISP)	DoDI 4630.8 and DoD Directive 4630.5, references (ar) and (as)	Program Initiation for Ships Preliminary Assessment MS B and C

III. DATA

A. INTRODUCTION

This section of the paper provides greater detail on how the PVPC works, presents test data from various sources, provides a more in depth description of the TRA process, and discusses points and methods by which the technology can be inserted into the acquisition framework.

B. PRODUCT DESCRIPTION: CONVERTING SOLAR POWER

To understand what the PVPC does, it helps to understand the environment in which it operates. The power (Watts) generated by a PV panel varies significantly based on three primary factors: the efficiency of the panel itself, the amount of sunlight hitting the surface of the panel, and the load applied to the system. The efficiency of the panel is a function of the material used to construct it, and once constructed, cannot be changed. The amount of light hitting the surface of the panel depends on external environmental and geographical factors, such as the latitude at which the panel is located or the amount of shadow cast on the panel by terrestrial objects or clouds. In our tests, we measured the amount of light hitting the surface of the panel in Lumens per square meter (otherwise known as Lux). In our research, we found that another commonly used measure of the energy striking the surface of the panel is Watts per square meter (W/m^2). Lastly, the attached devices that require power (a laptop computer, calculator, or a battery in our case) represent the load applied to the system.

Commercially available panels, typically with low conversion efficiencies of 10% or less, have power outputs that are extremely sensitive to lighting conditions and the load factor placed on the system. As the amount of light energy striking the surface of the panel varies, the potential power the panel can produce is constantly in flux. If the light energy falling on the panel is insufficient to generate the required Voltage or Amperage needed, the load will shut off or cease to charge. The panel is still producing power, but either the Voltage or Amperage components are insufficient to meet the threshold requirements of the load; therefore, no usable power is being produced.

Figure 2 below shows a plot of Current (in milliamps on the Y axis) vs. Voltage (on the X axis) produced by a Solengy solar cell (red) and a competitors cell (blue) under decreasing light energy levels from 200W/m², 100W/m², and finally 50W/m² respectively. This figure graphically represents the decreasing light scenario mentioned above in which the light energy at 50W/m² does not generate enough voltage for the lowest blue line to intersect the 12V battery's charging window.

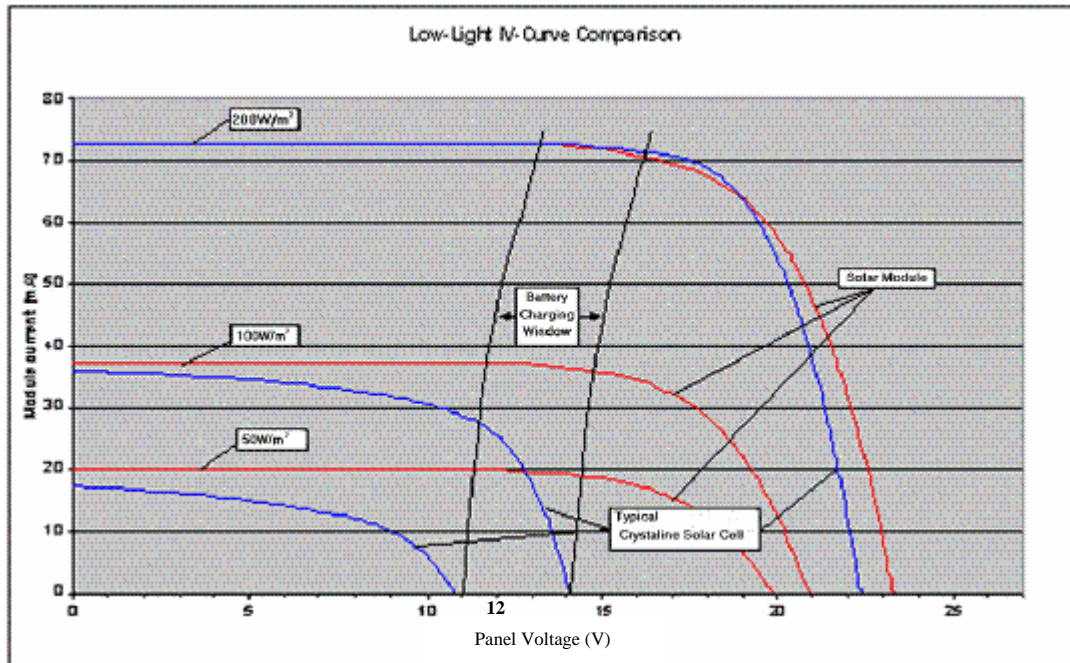

Figure 2. Low Light Effect on Battery Charging (After: <http://www.solengy.com/pages/whitepapers.html>), April 2005)

Alternatively, if the load attached to the system attempts to draw too much current (Amps) from the panel, even in good lighting conditions, the Voltage across the circuit will drop to zero and no power is produced ($0V * X\text{Amps} = 0\text{Watts}$). This scenario is depicted in the figure above by starting at the left of any line and noticing that at maximum amperage achieved, the voltage is zero, which means no power is being produced.

To address the variability of the amount of light energy striking the panel and the varying demands of the load, the PVPC incorporates two critical technologies – Maximum Power Point Tracking (MPPT) and Switch Mode Power Conversion (SMPC).

Both of these technologies are proven and have been commercially available for years. Making use of these two technologies, Atira claims it can recover as much as 25% of the available power that is currently wasted in conventional conversion techniques; thereby essentially increasing the overall efficiency of the PV system [not the cell itself] by this amount.⁷⁰ The PVPC is unique because it applies these technologies to an area of low power production, namely photovoltaic panels, which had previously received little attention from power conversion designers.

1. Maximum Power Point Tracking (MPPT)

The concept behind MPPT is that the circuit continuously monitors and optimizes the interface between the solar panel and the load/battery. The only way to continuously maximize the power output based on these two ever-changing inputs is for the output load to be constantly adjusted based on the level of exposure of the PV panel to the sun. However, current MPPT circuits are designed only to optimize the panel input within a narrow range, as shown in Figure 2. In other words, when the light energy striking the surface of the panel is sufficient to generate a voltage that is within the battery's charging window, the MPPT circuit maximizes the amount of power that can be produced by that amount of light. If the light energy is insufficient to cross the threshold, no power is produced – it only maximizes what makes it into the window. The result is a PV panel with a specific nominal voltage, such as the Solengy panel graphed above (12V panel) matched to the load of a 12V battery. The panel cannot charge a load that exceeds its voltage window, such as an 18V battery. Below in Figure 3 is a schematic of a standard MPPT circuit.

⁷⁰ Alexander Wolf, "Photovoltaic Power Conversion Technology Enhancements: Design a circuit that will track max pwr pt," (Unpublished Document, Atira Technologies, Los Gatos, CA: 2004), 2

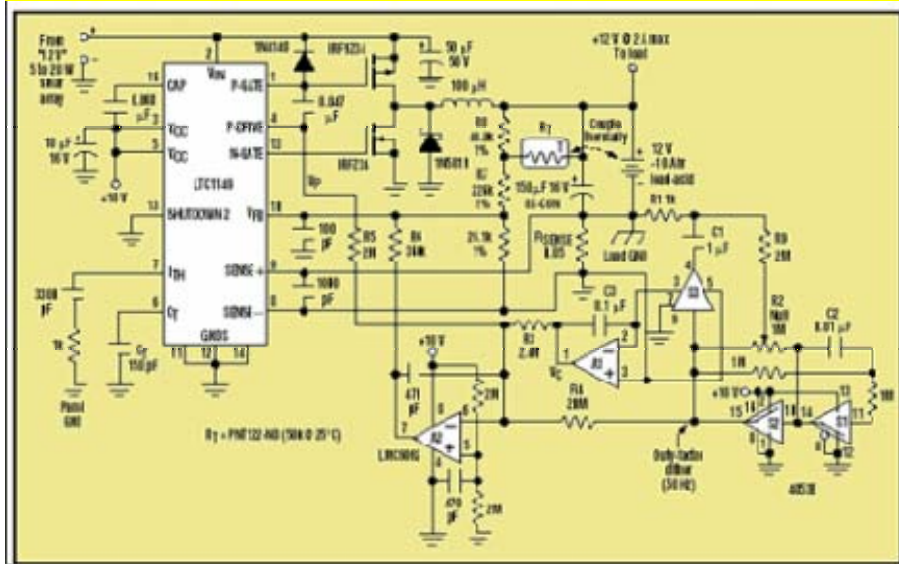

Figure 3. Schematic of Maximum Power Point Tracking Circuit. (From: <http://www.elecdesign.com/Articles/ArticleID/6262/6262.html>), April 2005)

2. Switch Mode Power Conversion

Switch mode power conversion is the method by which the PVPC continuously adjusts the output load based on the amount of sunlight striking the surface of the panel. “In all applications of switch mode power conversion, input power to the converter is equal to the output power generated by the converter, assuming no losses within the conversion process. Simply stated, 6 volts at 1 amp [output of the solar panel] is converted to 12 volts at 0.5 amps [by the PVPC].”⁷¹ If the load on the PV system is a typical 12V battery, it has an approximate charging window between 11V and 14V. Voltages produced by the panel that are less than 11V or more than 14V are unusable for charging the battery and therefore wasted energy (as shown in Figure 2). However, if you change the component characteristics of the power so that the 6V and 1A produced by the panel is converted into 12V and 0.5A, the threshold for battery charging is achieved. Also, if the SMPC can convert the 6V and 1A into 18V and .33A it can now charge an 18V battery, something a 12V panel could never do before. By using the

⁷¹ David A. Besser, “Photovoltaic Power Conversion Technology: Reserved Backup Power,” (Unpublished Document, Atira Technologies, Los Gatos, CA: May 12, 2004), 2

second concept of switch mode power conversion, the PVPC can both expand the range of batteries it can charge or applications it can power and extend the usable range of input solar energy.

The PVPC changes the components of the power equation by switching the mode of the power, produced by the panel, from Direct Current (DC) to Alternating Current (AC). Once switched to AC, the energy now has another component characteristic – frequency, as measured in Hertz (Hz). By modulating the frequency to a higher level and then switching back to DC, the voltage is dramatically increased and the current is proportionally decreased to stay within the laws of $V \cdot A = W$. The result is a usable voltage level being produced by the system that can satisfy the load, whereas before voltage produced was too low to be usable. In the situation just discussed in which the panel is only producing unusable power, it can be argued that PVPC infinitely improves the system. We designed our tests to determine if a solar power system with the PVPC integrated produces more power than a system without the technology.

3. Relevant Range of the PVPC

Currently, Atira is building the PVPC by hand from commercially available components. Each PVPC is built to optimize a particular panel's power production. The three PVPC circuits we tested are known as the 0512, 0916, and the 1216 circuit boards. The first two numbers of each four number grouping indicate the input Voltage of the panel the circuit was designed to optimize. While the last two numbers give the nominal upper Voltage limit the circuit can produce based upon that input voltage. For instance, the 0916 circuit is designed to optimize the power output of a 9V solar panel and can increase that Voltage up to about 16V. Therefore, as currently produced, one size does not fit all applications. When constructing the PVPC, designers must consider the particular power production characteristics of the solar panel as well as the power requiring characteristics of the load.

The original PVPC circuit was the 1216, designed to work with the 12V Solengy glass panel. The 1216 was then subsequently modified into the 0916 to work with the 9v Uni-Solar LM-3 panel. The modification was done as a proof of concept to show that

with the 0916 PVPC a 9V panel could indeed charge a 12V battery (see Table 2 test results). However, the design was never matured to optimize at the 9V input level (see Table 12 test results).

4. Physical Description

Figure 4, below, shows the physical appearance of the PVPC at the time of our April 2005 tests. Atira currently builds the PVPC by hand, on a printed circuit board with various capacitors, inductors, resistors, and input and output receptacles soldered on. It is 1.9375 inches (horizontally) by 1.625 inches (vertically) as shown below.

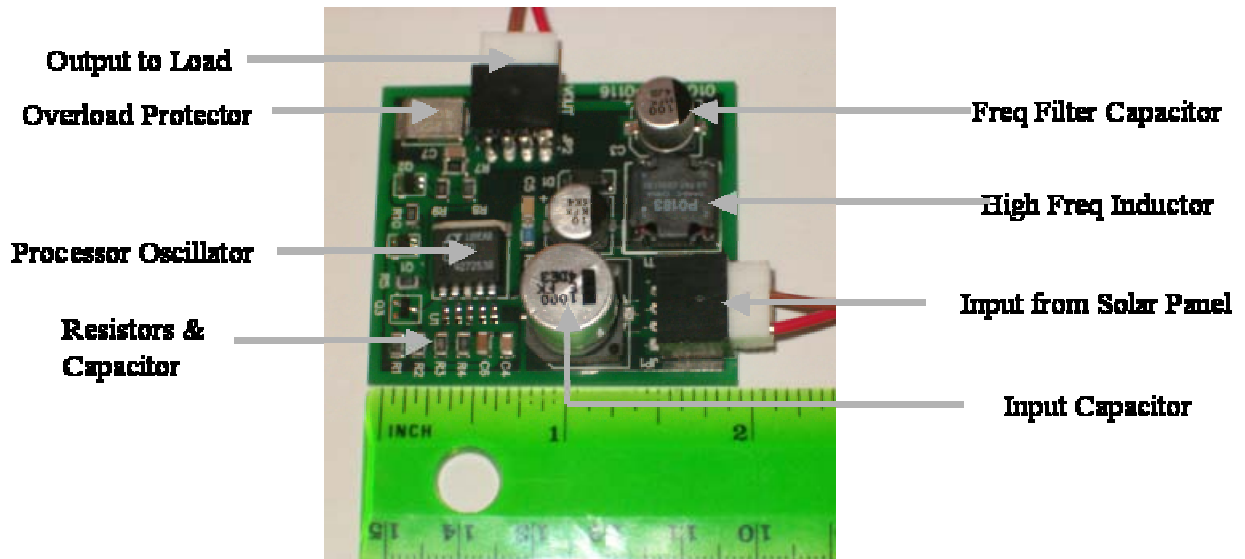

Figure 4. Digital Photograph of the PVPC

5. Next Generation of the PVPC⁷²

For any new technology or product, the ability to economically manufacture is an important consideration. Atira realizes that the current method of production cannot support large orders. With this in mind, the company is working with potential manufacturers to both miniaturize and mass-produce the technology. “In its final form, the PVPC will be an integrated circuit not much larger than a postage stamp”. They also see the need to give the PVPC its own automated processor, so it can optimize electronically, over a far greater range of input panel voltage and power, what it is now doing with hand-soldered hardware. “The next generation PVPC will be designed with a

⁷² Stephan Matan, PVPC Inventor, telephone conversation with authors, 4 May 2005.

built in microprocessor that will allow it to optimize input Voltage from zero to 30V and power from zero to 200W to meet the demand of the load”.

The manufacturing and miniaturization technologies to build microprocessors and other electronic components are mature. The ability to literally grow the silicon crystals and print the circuit pattern on the wafer is known as photolithography. This is a manufacturing method routinely applied in fabrication facilities where chips such as Intel or AMD microprocessors are manufactured, which allows the wafer to electronically replicate the hardware shown in Figure 4.

6. Summary of How It Produces Power

Based on the preceding explanation of the two critical PVPC operating characteristics, we provide the following concise description of how it produces usable power. Using switch mode power conversion, the PVPC continuously modifies the characteristics of the inherently variable power produced by the panel to provide the maximum amount of usable power, within a relevant range, to the attached load; it does this based on its changing power requirements, as determined by the maximum power point tracking circuit.

C. PRODUCT TEST DATA

This section presents the data collected from multiple tests conducted to evaluate the PVPC. We grouped test data according to the primary organization that conducted the tests. Item 1, Atira Technologies Comparison Tests, presents data for tests conducted by Atira Technologies. Item 2, NPS Field Tests, presents data from independent tests conducted by the authors of this project. Item 3, Raven Designs Field Tests, concludes the presentation of test data section of this report. In this chapter, we present only the data and conditions for each of the tests. We discuss the analysis and conclusions for the tests in Chapter IV.

1. Atira Technologies Comparison Tests

Atira Technologies conducted comparison tests using Uni-Solar flexible solar panels and the Global Solar P-4 Array. The test approach used was a side-by-side comparison of solar power systems using procedures that measured the PVPC's

performance levels. Each test consisted of testing two identically configured systems, one with and one without the PVPC technology integrated.

a. Atira LM-3 Test with 12V Load

On 8 February 2005, Atira Tech used the Uni-Solar LM-3 modules and UBC36106102/PCM Ultra-Life Polymer 3.7V Rechargeable batteries for these tests (Figure 5). For each solar system, Atira representatives wired three Ultra-Life Polymer batteries in series to create a 12V battery load.

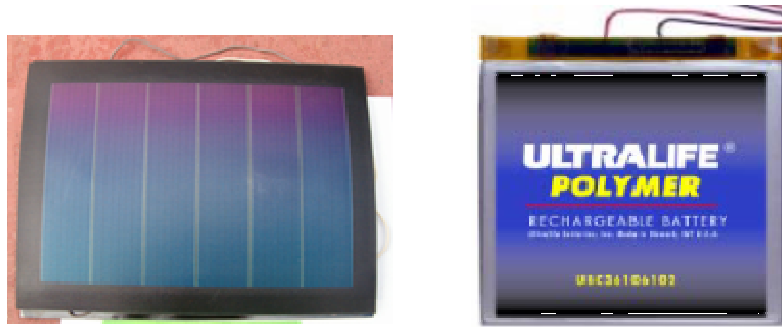

Figure 5. Uni-Solar LM-3 Solar Module and Ultra-Life Polymer Battery⁷³

The key data elements recorded during the tests were the current and load. For each solar power system, Atira measured performance of the systems in Volts and current in milliamperes (milliamps or mA). Presented below is the data for the LM-3 tests conducted by Atira.

⁷³ Picture of Ultra-Life Polymer Battery From: Electronic Product Brochure,1.

Table 2. LM-3 12V Test, Feb 8, 2005

LM3 12V Test (Feb 8)						
	Standard System			PVPC System		
Time	mA	V	Watts	mA	V	Watts
0730	0	11.43	0	0	11.59	0
0800	0	11.43	0	4	11.59	46.36
0830	10	11.43	114.3	4	11.59	46.36
0845	25	11.43	285.75	40	11.59	463.6
0915	50	11.43	571.5	100	11.59	1159
0920	50	11.43	571.5	100	11.60	1160
1000	50	11.43	571.5	100	11.59	1159
1200	50	11.43	571.5	100	11.66	1166
1245	10	11.43	114.3	50	11.66	583
1315	50	11.43	571.5	100	11.69	1169
1345	20	11.43	228.6	75	11.73	879.75
1430	10	11.43	114.3	75	11.73	879.75
1515	0	11.43	0	50	11.73	586.5
1545	0	11.43	0	50	11.73	586.5
1615	0	11.43	0	50	11.73	586.5
1645	0	11.43	0	50	11.73	586.5
1715	0	11.43	0	0	11.73	0
1716	0	11.43	0	0	11.73	0

b. Atira LM-3 Test with Programmable Fixed Load

Atira Tech used the Uni-Solar LM-3 modules and the HP 6063B DC Programmable Electronic Load system for this test. The HP 6063B is a programmable DC load bank that is used to apply a consistent and specific load source to the test systems simultaneously. The test approach was a side-by-side comparison test. The goal of the test was to measure the power output of the Standard system and the PVPC system under identical conditions and using identical loads. Using the HP 6063B, Atira began with a minimum load of 0.5V and incrementally increased the loads by 0.5V until they reached a maximum load of 16.5V for each system. For this test, Atira integrated a 0916 PVPC circuit board. Table 3 presents the data for this test.

Table 3. LM-3 Test with Programmable Fixed Load, Feb 20, 2005

LM-3 Flex Test w/ Programable Fixed Load											
System without PVPC			System with PVPC			System without PVPC			System with PVPC		
Voltage (V)	Current (mA)	Watts (mW)	Voltage (V)	Current (mA)	Watts (mW)	Voltage (V)	Current (mA)	Watts (mW)	Voltage (V)	Current (mA)	Watts (mW)
0.5	210	105	0.5	790	395	8.5	180	1530	8.5	150	1275
1	210	210	1	650	650	9	180	1620	9	140	1260
1.5	200	300	1.5	550	825	9.5	170	1615	9.5	130	1235
2	200	400	2	470	940	10	160	1600	10	120	1200
2.5	200	500	2.5	400	1000	10.5	140	1470	10.5	120	1260
3	200	600	3	350	1050	11	110	1210	11	110	1210
3.5	200	700	3.5	320	1120	11.5	70	805	11.5	110	1265
4	200	800	4	280	1120	12	20	240	12	100	1200
4.5	200	900	4.5	260	1170	12.5	0	0	12.5	100	1250
5	200	1000	5	230	1150	13	0	0	13	100	1300
5.5	200	1100	5.5	210	1155	13.5	0	0	13.5	90	1215
6	190	1140	6	200	1200	14	0	0	14	90	1260
6.5	190	1235	6.5	190	1235	14.5	0	0	14.5	90	1305
7	190	1330	7	170	1190	15	0	0	15	80	1200
7.5	190	1425	7.5	160	1200	15.5	0	0	15.5	80	1240
8	190	1520	8	150	1200	16	0	0	16	70	1120
						16.5	0	0	16.5	0	0

c. Atira P-4 Test with Programmable Fixed Load

Atira Tech used the Global Solar P-4 Array and the HP 6063B DC Programmable Electronic Load system for this test. The Global Solar P-4 Array (Figure 6) consists of 18 individual Global Solar modules. Each module produces 1.67 volts. Atira integrated six 0516 PVPC circuit boards in a 3:1 module to circuit board ratio.



Figure 6. Global Solar P-4 Array (From: Atira Technologies)

The HP 6063B is a programmable DC load bank that is used to apply a consistent and specific load source to the test systems simultaneously. The goal of the test was to measure the power output of the Standard system and the PVPC system under identical conditions. Using the HP 6063B, Atira began with a minimum load of 1V and

incrementally increased the loads by 0.5V until they reached a maximum load of 33V for each system. Table 4 presents the data for this test.

Table 4. Global Solar P-4 Test with Programmable Fixed Load

Global Solar P-4 Test w/ Programmable Fixed Load											
System without PVPC			System with PVPC			System without PVPC			System with PVPC		
Voltage (V)	Current (mA)	Watts (mW)	Voltage (V)	Current (mA)	Watts (mW)	Voltage (V)	Current (mA)	Watts (mW)	Voltage (V)	Current (mA)	Watts (mW)
1	1870	1870	1	8800	8800	17.5	1110	19425	17.5	1190	20825
1.5	1850	2775	1.5	7500	11250	18	1090	19620	18	1140	20520
2	1840	3680	2	6900	13800	18.5	1060	19610	18.5	1100	20350
2.5	1820	4550	2.5	6000	15000	19	1030	19570	19	1040	19760
3	1810	5430	3	5480	16440	19.5	980	19110	19.5	990	19305
3.5	1790	6265	3.5	5000	17500	20	950	19000	20	960	19200
4	1780	7120	4	4550	18200	20.5	890	18245	20.5	900	18450
4.5	1760	7920	4.5	4200	18900	21	860	18060	21	880	18480
5	1740	8700	5	3820	19100	21.5	780	16770	21.5	800	17200
5.5	1720	9460	5.5	3500	19250	22	710	15620	22	780	17160
6	1710	10260	6	3320	19920	22.5	650	14625	22.5	700	15750
6.5	1690	10985	6.5	3000	19500	23	590	13570	23	610	14030
7	1670	11690	7	2900	20300	23.5	500	11750	23.5	500	11750
7.5	1650	12375	7.5	2750	20625	24	470	11280	24	470	11280
8	1630	13040	8	2590	20720	24.5	420	10290	24.5	420	10290
8.5	1610	13685	8.5	2410	20485	25	310	7750	25	320	8000
9	1590	14310	9	2320	20880	25.5	110	2805	25.5	290	7395
9.5	1560	14820	9.5	2200	20900	26	80	2080	26	260	6760
10	1540	15400	10	2110	21100	26.5	0	0	26.5	240	6360
10.5	1520	15960	10.5	2000	21000	27	0	0	27	220	5940
11	1510	16610	11	1920	21120	27.5	0	0	27.5	190	5225
11.5	1490	17135	11.5	1810	20815	28	0	0	28	160	4480
12	1470	17640	12	1770	21240	28.5	0	0	28.5	140	3990
12.5	1450	18125	12.5	1700	21250	29	0	0	29	120	3480
13	1410	18330	13	1630	21190	29.5	0	0	29.5	90	2655
13.5	1390	18765	13.5	1580	21330	30	0	0	30	80	2400
14	1360	19040	14	1520	21280	30.5	0	0	30.5	60	1830
14.5	1330	19285	14.5	1490	21605	31	0	0	31	40	1240
15	1300	19500	15	1410	21150	31.5	0	0	31.5	25	787
15.5	1260	19530	15.5	1380	21390	32	0	0	32	10	320
16	1220	19520	16	1330	21280	32.5	0	0	32.5	5	162
16.5	1180	19470	16.5	1290	21285	33	0	0	33	0	0
17	1140	19380	17	1240	21080						

2. NPS Field Tests

We independently tested the PVPC April 6-11, 2005. Our objective was to validate the tests conducted by Atira Technologies and to verify that a solar power system integrated with the PVPC technology would produce more power than an identical system without the technology. The test approach used was a side-by-side comparison of solar power systems using procedures that measured the PVPC's performance levels. We conducted the tests in the uncontrolled, natural environment that existed on the scheduled test days with the intention of capturing performance data relevant to a typical temperate climate. Each test consisted of using two identically configured systems, one with and one without the PVPC technology (Figure 7). The test plan provided in appendix A, details the setup and procedures we used to conduct each test.

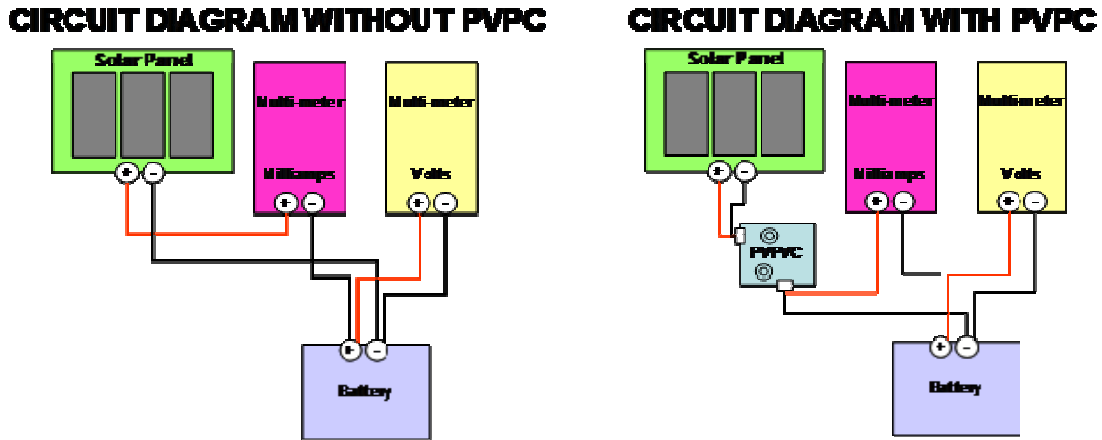

Figure 7. NPS PVPC Field Test Configurations

The key data elements of the tests were the performance results of the solar power systems. For each solar power system, we measured performance of the systems in Volts and current in milliamps (mA). To measure relevant light conditions of the environment, we used light meter readings (Lux). We recorded data photographically to capture an instantaneous “snapshot” and to ensure exact readings of all meters at the same point in time. We then transferred the photographic data elements for the Volts, mA and Lux to a spreadsheet for presentation and analysis. Additional data recorded during the test included solar panel surface temperature readings and hourly weather conditions in the area. We recorded this data to further document relevant light and environmental conditions in order to help the reader understand the actual conditions during the test and correlate them to the Lux meter readings.

a. Glass Panel-7.4V Battery Field Performance Test

The solar panels used for the glass panel 7.4V tests were Solengy ASI-F 5/12 framed solar modules. The batteries used were UBC36106102/PCM Ultra-Life Polymer 3.7V Rechargeable batteries. For each system, we wired two of these batteries in series to create a 7.4V battery load for glass tests 1-3. The PVPC technology circuit board was a model 1216. Tables 5-7 present the data for Glass Panel Tests 1 through 3.

Table 5. Glass Test 1 With 7.4V Battery

Glass Test 1 With 7.4V Battery (6 April 05)									
Time	Light Reading (Lux)	Glass A				Glass B With PVPC			
		Array Temp	Battery Current (mA)	Battery Voltage	Watts (mW)	Array Temp	Battery Current (mA)	Battery Voltage	Watts (mW)
8:00 AM	25800	63	100	7.76	776.0	61	135	7.71	1040.85
8:15 AM	34400	71	125	7.78	972.5	67	160	7.74	1238.4
8:30 AM	18400	62	52	7.75	403.0	58	98	7.71	755.58
8:45 AM	21100	61	70	7.76	543.2	58	100	7.73	773
9:00 AM	24000	61	81	7.77	629.4	58	125	7.75	968.75
9:15 AM	28200	64	100	7.78	778.0	63	150	7.75	1162.5
9:30 AM	72000	99	250	7.83	1957.5	97	380	7.85	2983
9:45 AM	70600	101	270	7.84	2116.8	99	400	7.87	3148
10:00 AM	64200	92	225	7.84	1764.0	89	360	7.87	2833.2
10:15 AM	66900	96	250	7.87	1967.5	95	375	7.9	2962.5
10:30 AM	82400	105	300	7.9	2370.0	102	425	7.93	3370.25
10:45 AM	60900	96	220	7.92	1742.4	92	330	7.94	2620.2
11:00 AM	71600	86	235	7.94	1865.9	83	370	7.96	2945.2
11:15 AM	64400	88	245	7.96	1950.2	81	350	7.99	2796.5
11:30 AM	60600	92	220	7.98	1755.6	86	320	8.02	2566.4
11:45 AM	96800	92	325	8.03	2609.8	85	460	8.08	3716.8

Table 6. Glass Test 2 With 7.4V Battery

Glass Test 2 With 7.4V Battery (6 April 05)									
Time	Light Reading (Lux)	Glass A				Glass B With PVPC			
		Array Temp	Battery Current (mA)	Battery Voltage	Watts (mW)	Array Temp	Battery Current (mA)	Battery Voltage	Watts (mW)
12:15 PM	72600	105	308	7.23	2226.8	99	452	7.26	3281.5
12:30 PM	102200	110	409	7.41	3030.7	105	535	7.53	4028.6
12:45 PM	70900	104	257	7.46	1917.2	96	401	7.59	3043.6
1:00 PM	99100	110	390	7.56	2948.4	105	502	7.69	3860.4
1:15 PM	98500	117	376	7.57	2846.3	109	494	7.72	3813.7
1:30 PM	99100	115	377	7.58	2857.7	108	476	7.75	3689.0
1:45 PM	98900	113	369	7.61	2808.1	108	473	7.79	3684.7
2:00 PM	97800	112	359	7.63	2739.2	107	456	7.82	3565.9
2:15 PM	97000	109	347	7.65	2654.6	103	450	7.85	3532.5
2:30 PM	95400	110	336	7.67	2577.1	105	430	7.87	3384.1
2:45 PM	93300	107	318	7.69	2445.4	101	412	7.89	3250.7
3:00 PM	91300	107	305	7.7	2348.5	101	398	7.91	3148.2
3:15 PM	88900	99	287	7.72	2215.6	94	380	7.93	3013.4
3:30 PM	85700	96	270	7.73	2087.1	91	358	7.95	2846.1
3:45 PM	83200	92	253	7.75	1960.8	91	341	7.98	2721.2
4:00 PM	78300	86	230	7.75	1782.5	83	314	8	2512.0
4:15 PM	75600	85	211	7.76	1637.4	82	288	8.01	2306.9
4:30 PM	71700	77	192	7.77	1491.8	76	264	8.04	2122.6
4:45 PM	55900	69	118	7.76	915.7	66	166	8.03	1333.0
5:00 PM	33000	64	73	7.76	566.5	62	110	8.03	883.3
5:15 PM	47200	64	110	7.77	854.7	64	155	8.05	1247.8
5:30 PM	28600	73	78	7.77	606.1	69	120	8.06	967.2

Table 7. Glass Test 3 With 7.4V Battery

Glass Test 3 With 7.4V Battery (7 April 05)									
Time	Light Reading (Lux)	Glass A				Glass B With PVPC			
		Array Temp	Battery Current (mA)	Battery Voltage	Watts (mW)	Array Temp	Battery Current (mA)	Battery Voltage	Watts (mW)
7:15 AM	500	50	2	7.5	15	50	0	7.41	0
7:30 AM	1400	51	5	7.5	37.5	51	0	7.41	0
7:45 AM	1800	51	7	7.51	52.57	51	0	7.41	0
8:00 AM	3600	52	14	7.52	105.28	52	3	7.42	22.26
8:15 AM	7100	47	24	7.53	180.7	48	22	7.43	163.46
8:30 AM	9700	49	33	7.54	248.8	49	39	7.46	290.94
8:45 AM	13900	50	46	7.55	347.3	50	63	7.49	471.87
9:00 AM	8100	57	26	7.54	196.0	55	26	7.48	194.48
9:15 AM	900	54	32	7.55	241.6	52	37	7.49	277.13
9:30 AM	11700	54	37	7.55	279.4	53	48	7.51	360.48
9:45 AM	25700	59	101	7.6	767.6	57	159	7.58	1205.22
10:00 AM	33700	62	121	7.61	920.8	59	187	7.6	1421.2
10:15 AM	24000	63	87	7.6	661.2	60	147	7.59	1115.73
10:30 AM	42100	63	125	7.63	953.8	61	188	7.61	1430.68
10:45 AM	Data was not collected for this period.								
11:00 AM	39500	62	104	7.63	793.5	60	163	7.64	1245.32
11:15 AM	40600	62	106	7.64	809.8	59	159	7.65	1216.35
11:30 AM	52500	65	134	7.64	1023.8	62	208	7.68	1597.44
11:45 AM	68100	76	183	7.65	1400.0	69	275	7.71	2120.25

b. Glass Panel –3.7V Battery Field Performance Test

We conducted a single iteration of this test. The solar panels used were Solengy ASI-F 5/12 framed solar modules. The batteries used were UBC36106102/PCM Ultra-Life Polymer 3.7V Rechargeable. To test the system under a different load source, we intentionally wired two of these batteries in parallel to create a 3.7V battery load. The PVPC technology circuit board used was a model 1216. Presented below is the data for this test.

Table 8. Glass Test 4 With 3.7V Battery

Glass Test 4 With 3.7V Battery (10 April 05)									
Time	Light Reading (Lux)	Glass A				Glass B With PVPC			
		Array Temp	Battery Current (mA)	Battery Voltage	Watts (mW)	Array Temp	Battery Current (mA)	Battery Voltage	Watts (mW)
6:30 AM	75	42	0	3.75	0.00	42	0	3.74	0.00
Sunrise 6:40	499	42	1	3.75	3.75	42	0	3.75	0.00
6:45 AM	989	43	3	3.76	11.28	43	0	3.74	0.00
7:00 AM	3020	40	9	3.76	33.84	40	0	3.75	0.00
7:15 AM	6400	47	21	3.77	79.17	46	20	3.75	75.04
7:30 AM	11000	52	35	3.77	131.95	51	49	3.76	184.34
7:45 AM	10000	44	33	3.77	124.41	44	48	3.76	180.62
8:00 AM	29300	52	55	3.78	207.90	52	91	3.77	343.43
8:15 AM	17100	57	55	3.78	207.90	57	94	3.78	354.85
8:30 AM	31700	59	100	3.79	379.00	60	173	3.79	655.67
8:45 AM	44700	66	138	3.80	524.40	66	235	3.80	893.00
9:00 AM	51500	75	163	3.80	619.40	78	272	3.80	1034.69
9:15 AM	57700	82	186	3.80	706.80	83	302	3.81	1150.02
9:30 AM	63400	86	208	3.81	792.48	91	336	3.82	1281.84
9:45 AM	70200	73	231	3.81	880.11	77	369	3.83	1412.53
10:00 AM	75000	82	250	3.82	955.00	85	392	3.84	1504.10
10:15 AM	80800	56	269	3.83	1030.27	65	418	3.85	1607.21
10:30 AM	84500	82	286	3.83	1095.38	83	437	3.85	1682.45
10:45 AM	88800	89	299	3.84	1148.16	93	446	3.86	1719.33
11:00 AM	92800	88	315	3.84	1209.60	93	464	3.86	1789.65
11:15 AM	97800	90	326	3.85	1255.10	94	483	3.86	1865.35
11:30 AM	99800	77	334	3.86	1289.24	82	491	3.87	1898.70
11:45 AM	101800	85	345	3.87	1335.15	92	500	3.87	1935.50
12:00 PM	104800	88	353	3.87	1366.11	94	507	3.88	1964.63
12:15 PM	107300	90	360	3.88	1396.80	95	516	3.88	2002.08
12:30 PM	108000	82	365	3.88	1416.20	88	518	3.88	2009.84
12:45 PM	109200	84	368	3.88	1427.84	90	522	3.89	2027.97
1:00 PM	109800	77	368	3.88	1427.84	82	521	3.89	2027.21
1:15 PM	108800	83	365	3.89	1419.85	90	520	3.90	2026.44
1:30 PM	107200	83	365	3.89	1419.85	91	520	3.90	2030.08

c. Flexible Panel-7.4V Battery Field Performance Test:

We conducted a single iteration of this test. The solar panels used for the flexible panel 7.4V tests were Uni-Solar LM-3 modules. Each system utilized an array of three LM-3 modules. The batteries used were UBC36106102/PCM Ultra-Life Polymer 3.7V Rechargeable batteries with two batteries wired in series to create a 7.4V battery load. The PVPC technology circuit board used was a model 0916. Table 9 presents the data for this test.

Table 9. Flexible Panel Test With 7.4V Battery

Flex Test With 7.4V Battery (10 April 05)									
Time	Light Reading (Lux)	Flex A				Flex B With PVPC			
		Array Temp	Battery Current (mA)	Battery Voltage	Watts (mW)	Array Temp	Battery Current (mA)	Battery Voltage	Watts (mW)
10:30 AM	84500	96	739	7.77	5742.03	92	604	7.57	4572.28
10:45 AM	88800	107	738	7.85	5793.3	106	613	7.71	4726.23
11:00 AM	92800	105	787	7.95	6256.65	105	622	7.76	4826.72
11:15 AM	97800	101	820	8.03	6584.6	102	643	7.82	5028.26
11:30 AM	99800	93	825	8.09	6674.25	89	653	7.87	5139.11
11:45 AM	101800	98	823	8.14	6699.22	97	654	7.92	5179.68
12:00 PM	104800	102	810	8.18	6625.8	100	646	7.95	5135.7
12:15 PM	107300	104	813	8.23	6690.99	103	659	7.99	5265.41

d. Flexible Panel-3.7V Battery Field Performance Test

We conducted a single iteration of this test. The solar panels used for the flexible panel 3.7V tests were Uni-Solar LM-3 modules. Each system utilized an array of three LM-3 modules. The batteries used were UBC36106102/PCM Ultra-Life Polymer 3.7V Rechargeable batteries. For each system, we wired two of these batteries in parallel to create a 3.7V battery load for the test. The PVPC technology circuit board used was a model 1216. Presented below is the data for this test.

Table 10. Flexible Panel Test With 3.7V Battery

Flex Test With 3.7V Battery (10 April 05)									
Time	Light Reading (Lux)	Flex A				Flex B With PVPC			
		Array Temp	Battery Current (mA)	Battery Voltage	Watts (mW)	Array Temp	Battery Current (mA)	Battery Voltage	Watts (mW)
6:30 AM	75	45	0	3.8	0	45	0	3.7	0
Sunrise 6:40	499	45	5	3.8	19	45	0	3.7	0
6:45 AM	989	44	9	3.8	34.2	45	0	3.71	0
7:00 AM	3020	42	28	3.81	106.68	42	16	3.71	59.36
7:15 AM	6400	51	65	3.83	248.95	49	88	3.75	330
7:30 AM	11000	55	109	3.84	418.56	55	168	3.79	636.72
7:45 AM	10000	47	98	3.84	376.32	47	142	3.79	538.18
8:00 AM	29300	56	159	3.86	613.74	54	250	3.83	957.5
8:15 AM	17100	60	167	3.86	644.62	60	254	3.83	972.82
8:30 AM	31700	66	297	3.92	1164.24	66	447	3.87	1729.89
8:45 AM	44700	79	421	3.96	1667.16	76	562	3.89	2186.18
9:00 AM	51500	84	488	3.99	1947.12	83	657	3.91	2568.87
9:15 AM	57700	94	552	4.00	2208	91	711	3.93	2794.23
9:30 AM	63400	102	614	4.03	2474.42	98	762	3.97	3025.14
9:45 AM	70200	91	674	4.07	2743.18	87	824	3.99	3287.76
10:00 AM	75000	102	725	4.1	2972.5	97	855	4.01	3428.55

3. Raven Designs Field Tests

Atira Technologies collaborated with Raven Designs to integrate the PVPC technology into one of Raven Designs' newly developed solar charging products, the SBR Solar Pack Cover. The SBR (Figure 8) is a backpack cover that will fit any size backpack. Integrated into the cover are ten Uni-Solar LM-3 modules. Raven Designs, Lafayette California, designed the SBR to recharge the UBI 2590 rechargeable battery, a battery used extensively by U.S. military forces..



Figure 8. SBR Deployed on a pack and flat on the ground. (After: Raven Designs Product Brochure)

During the first week of November 2004, Steve Locher, designer of the SBR, spent a week testing the product in Kodiak, Alaska. He conducted his test with U.S. Navy Seal Instructors at the Northern Warfare Training Center in a simulated operational environment with user input. Provided below are Mr. Locher's comments on the test:

A drained UBI-2590 15V/30V rechargeable LithiumManganeseDiOxide battery (rechargeable replacement for the BA5590) was plugged into the Solar Pack Cover to be recharged. Sunrise occurred approximately at 9 am, sunset at 5 pm. Sunrise temperature was 22_F, and sunset temperature was 40_F, with variable winds from 10 to 20 mph, gusts to 35 mph. Skies were clear of cloud cover. The Solar Pack Cover was laid out flat on the ground in a clearing of trees, being exposed to direct sunlight for a period of 4.5 hours, and shaded the balance of the test time, without being moved. The sun angle was very low (Kodiak sits at latitude 57°-45) and oblique. At 8 am the voltmeter plugged into the UBI-2590 battery registered 12.0 volts (empty), and at 5 pm sunset, the voltmeter registered 12.8 volts. Since 15.0 volts would be fully charged, the 0.8 volt increase in the battery indicates a 26.6% recharge. The UBI-2590 battery was a quarter recharged according to the indicator.⁷⁴

⁷⁴ Steve Locher, "Atira Technologies and Raven Designs Solar Array Results and Conclusions From Kodiak, Alaska," (Unpublished Information Paper, Raven Designs, November 11, 2004), 1.

Following the test conducted in Alaska, Mr. Locher conducted similar field-testing of the Solar Pack, with the integrated PVPC technology, in Monterey, CA. in a simulated operational environment. His descriptions and comments are:

...a test in Monterey, California (latitude 36°36'N) during the last week of November with the SBR at a 45 degree angle to the ground (roughly 90 degrees to the sun) and never moved to track the sun, recharged the same battery by 71% in 8 hours. The next day, also with clear skies, the SBR was hung from a tree (vertical to the ground), rotated once during the day to track the sun, and recharged the UBI-2590 battery in 8 hours. Testing in ideal conditions (summer sun, and the unit periodically rotated to roughly follow the sun) at mid latitudes, shows 100% UBI- 2590 battery recharging in less than 7 hours. These different testing conditions, from the low angle, partly shaded sun, to direct, full sun, illustrates the viability of this technology. When coupled with the field versatility of the Solar Battery Recharger by Raven Designs, the Warfighter is presented with a real world solution to many battlefield power supply problems. By reducing the weight and bulk of the required battery supply of today's Warfighter, individuals and units can move more quickly, safely, and with more endurance. By being able to recharge batteries in the field, mission durations can be safely lengthened.⁷⁵

D. TECHNOLOGY READINESS LEVEL DESCRIPTIONS⁷⁶

The purpose of this section is to describe in detail each Technology Readiness Level. As stated in Chapter II, Technology Readiness Levels are a consistent measurement to categorize the maturity level of a program's key technologies and provide a common language or reference to the science and technology community within the DoD. Developing a comprehensive understanding of each level and the supporting information required to justify an assessment is essential in conducting a thorough Technology Readiness Assessment. Items 1-9 below present each TRL definition followed by the supporting information necessary to justify an assessment for that level and an example.

⁷⁵ Steve Locher, "Raven Designs", (Unpublished Product Brochure, Raven Designs)

⁷⁶ The definitions, required supporting information, and examples for each TRL are cited/paraphrased from the DoD Technology Readiness Assessment Deskbook, September, 2003

1. TRL 1: Basic Principles Observed and Reported

a. Description

TRL 1 is the lowest level of technology readiness. At this level, scientific research begins to be translated into applied research and development.

b. Supporting Information

Supporting information required includes published research that identifies the principles that underlie this technology. References must include whom, where and when.

c. Example

Examples of TRL 1 include paper studies of technologies basic properties.

2. TRL 2: Technology Concept and/or Application Formulated

a. Description

Invention begins at TRL 2. Once basic principles are observed, practical applications can be invented. At TRL 2 applications are speculative, and proof or detailed analysis to support the assumptions may be lacking.

b. Supporting Information

Supporting information for TRL 2 include publications or other references that outline the application being considered and that provide analysis to support the concept.

c. Example

Examples of TRL 2 include analytical studies.

3. TRL 3: Analytical and Experimental Critical Function and/or Characteristic Proof of Concept

a. Description

TRL 3 is characterized by the initiation of active research and development that includes analytical studies and laboratory studies to physically validate analytical predictions of separate elements of the technology.

b. Supporting Information

Supporting information include results of laboratory tests performed to measure parameters of interest and comparison to analytical predictions for critical subsystems. References must include who, where, and when the tests and comparisons were performed.

c. Example

Examples include components that are not yet integrated or representative.

4. TRL 4: Component and/or Breadboard Validation in a Laboratory Environment

a. Description

At level TRL 4 basic technological components are integrated to establish that they will work together. This is relatively ‘low fidelity’ compared to the eventual system.

b. Supporting Information

Supporting information necessary include systems concepts that have been considered and results from testing laboratory-scale breadboard(s). References must provide who, where, and when the tests and comparisons were performed.

c. Example

Integration of “ad hoc” hardware in the laboratory.

5. TRL 5: Component and/or Breadboard Validation in a Relevant Environment

a. Description

Fidelity of breadboard technology increases significantly at TRL 5. The basic technological components are integrated with reasonably realistic supporting elements so they can be tested in a simulated environment.

b. Supporting Information

Supporting information consist of results from testing a laboratory breadboard system that are integrated with other supporting elements in a simulated operational environment. Documentation should address questions such as, how the relevant environment differs from the expected operational environment; how do the test results compare with expectations; what problems, if any, were encountered; was the breadboard system refined to match the expected system goals more nearly?

c. Example

Examples of TRL include “high-fidelity” laboratory integration of components.

6. TRL 6: System/Subsystem Model or Prototype Demonstration in a Relevant Environment

a. Description

TRL 6 is characterized by a representative model or prototype system, which is well beyond that of TRL 5 that is tested in a relevant environment. This level represents a major step up in a technology’s demonstrated readiness.

b. Supporting Information

Supporting information should consist of results from laboratory testing of a prototype system that is near the desired configuration in terms of performance, weight, and volume. Questions to address are how did the test environment differ from the operational environment? Who performed the tests? How did the test compare with expectations? What problems, if any, were encountered? What are/were the plans, options, or actions to resolve problems before moving to the next level?

c. Example

Examples include testing a prototype in a high fidelity laboratory environment or in a simulated operational environment.

7. TRL 7: System Prototype Demonstration in an Operational Environment

a. Description

At TRL 7 a prototype near, or at, the planned operational system is realized. TRL 7 represents a major step up from TRL 6. It requires a demonstration of an actual operational system prototype in an operational environment such as an aircraft, vehicle, or space.

b. Supporting Information

Supporting information should include results of testing a prototype system in an operational environment. Questions to address are: Who performed the

tests? How did the test compare with expectations? What problems, if any, were encountered? What are/were the plans, options, or actions to resolve problems before moving to the next level?

c. Example

An example for TRL 7 is testing the prototype in a test bed aircraft.

8. TRL 8: Actual System Completed and Qualified Through Test and Demonstration

a. Description

At TRL 8, the technology has been proved to work in its final form and under expected conditions. In almost all cases, this TRL represents the end of true system development.

b. Supporting Information

Supporting information should include results of testing the system in its final configuration under the expected range of environmental conditions in which it will be expected to operate. Assessments at TRL 8 must also determine whether it will meet its operational requirements. Questions to address are: What problems, if any, were encountered? What are/were the plans, options, or actions to resolve problems before finalizing the design?

c. Example

Examples for TRL 8 include developmental test and evaluation of the system in its intended weapon system to determine if it meets design specifications.

9. TRL 9: Actual System Proven Through Successful Mission Operations

a. Description

TRL 9 is the highest level of technology readiness. This level is describe as the actual application of the technology in its final form and under mission conditions, such as those encountered in operational test and evaluation.

b. Supporting Information

Supporting information is reports and results from operational test and evaluation.

c. Example

Examples include using the system under operational mission conditions.

E. DOD TECHNOLOGY INSERTION MEHODS

In Chapter II, we presented the overall acquisition framework (Figure 9) and the integration (such as horizontal technology insertion) and assessment of technologies developed through an approved developmental program. This section discusses alternative insertion methods for inserting Aтира Technologies’ PVPC device into the DoD Acquisition process. The two potential methods presented are insertion as a commercial item and/or as an Advanced Concept Technology Demonstration (ACTDACTD).



Figure 9. Defense Acquisition Framework. (After: DoDI 5000.2, May 2003)

1. Commercial Item

Excerpts from the Office of the Secretary of Defense, Acquisition, Technology and Logistics, Commercial Item Handbook are provided below. The first excerpt defines a commercial item and the second excerpt is a discussion of the definition to provide further understanding.

a. Commercial Item Definition⁷⁷

COMMERCIAL ITEM (FEDERAL ACQUISITION REGULATION [FAR] 2.101)

(a) Any item, other than real property, that is of a type customarily used by the general public or by nongovernmental entities for purposes other than governmental purposes, and that—

- (1) Has been sold, leased, or licensed to the general public; or

⁷⁷ This section in its entirety is an excerpt from the *Commercial Item Handbook*, Office of the Secretary of Defense Acquisition, Technology and Logistics, November 2001, Appendix C

(2) Has been offered for sale, lease, or license to the general public;

(b) Any item that evolved from an item described in paragraph (a) of this definition through advances in technology or performance and that is not yet available in the commercial marketplace, but will be available in the commercial marketplace in time to satisfy the delivery requirements under a Government solicitation;

(c) Any item that would satisfy a criterion expressed in paragraphs (a) or (b) of this definition, but for—

(1) Modifications of a type customarily available in the commercial marketplace; or

(2) Minor modifications of a type not customarily available in the commercial marketplace made to meet Federal Government requirements. “Minor” modifications means modifications that do not significantly alter the nongovernmental function or essential physical characteristics of an item or component, or change the purpose of a process. Factors to be considered in determining whether a modification is minor include the value and size of the modification and the comparative value and size of the final product. Dollar values and percentages may be used as guideposts, but are not conclusive evidence that a modification is minor;

(d) Any combination of items meeting the requirements of paragraphs (a), (b), (c), or (e) of this definition that are of a type customarily combined and sold in combination to the general public;

(e) Installation services, maintenance services, repair services, training services, and other services if—

(1) Such services are procured for support of an item referred to in paragraph (a), (b), (c), or (d) of this definition, regardless of whether such services are provided by the same source or at the same time as the item; and

(2) The source of such services provides similar services contemporaneously to the general public under terms and conditions similar to those offered to the Federal Government;

(f) Services of a type offered and sold competitively in substantial quantities in the commercial marketplace based on established catalog or market prices for specific tasks performed under standard commercial terms and conditions. This does not include services that are sold based on hourly rates without an established catalog or market price for a specific service performed. For purposes of these services—

(1) “Catalog Price” means a price included in a catalog, price list, schedule, or other form that is regularly maintained by the manufacturer or vendor, is either published or otherwise available for inspection by customers, and states prices at which sales are currently, or were last, made to a significant number of buyers constituting the general public; and

(2) “Market Prices” mean current prices that are established in the course of ordinary trade between buyers and sellers free to bargain and that can be substantiated through competition or from sources independent of the offerors; (g) Any item, combination of items, or service referred to in paragraphs (a) through (f), notwithstanding the fact that the item, combination of items, or service is transferred between or among separate divisions, subsidiaries, or affiliates of a contractor; or

(h) A nondevelopmental item, if the procuring agency determines the item was developed exclusively at private expense and sold in substantial quantities, on a competitive basis, to multiple State and local governments.

b. Discussion of Commercial Item Definition⁷⁸

The commercial item definition...is broad. It embraces any item of a type customarily used by the general public or by nongovernmental entities for purposes other than Government purposes that has been sold, leased, or licensed or offered for sale, lease, or license to the general public. Also included in the commercial item definition is any item that has evolved from a commercial item as described above, through technical/performance advances, even if it is not yet available in the commercial marketplace, as long as it will be available in time to satisfy the Government’s requirements. Commercial items do not necessarily have to be “off-the-shelf”; items that merely require modifications of a type customarily available in the commercial marketplace, or else minor Government-unique modifications, can still be considered commercial items. (To qualify as representing a minor modification, the item must retain a predominance of nongovernmental functions or physical characteristics.) Additionally, the FAR commercial item definition includes many services. A service is considered a commercial item when it is provided in support of a commercial item as previously defined. A service is also considered a commercial item when it is of a type offered and sold competitively in substantial quantities in the commercial market on the basis of established catalog or market prices for specific tasks performed under standard commercial terms and conditions. The definition also includes any combination of commercial items (except “of

⁷⁸ This section is an excerpt from the *Commercial Item Handbook*, Office of the Secretary of Defense Acquisition, Technology and Logistics, November 2001, 10

a type” services) that are customarily combined and sold in combination to the general public. The commercial item definition is not limited to items acquired by the Government from prime contractors; it also extends to commercial items acquired from subcontractors at all tiers, including items transferred from a contractor’s divisions, affiliates, or subsidiaries. Acquisition professionals are responsible for developing requirements and acquisition strategies that facilitate the inclusion of commercial items in Government-unique systems. Commercial off-the-shelf (COTS) items, nondevelopmental items (NDIs), and Government off the- shelf (GOTS) items are related to commercial items, but the terms are not synonymous. Further, the fact that a supply or service to be procured does not easily fit into the NDI or GOTS categories does not in itself mean that it is not a commercial item.

2. Advance Concept Technology Demonstration⁷⁹

This section provides excerpts from the Advanced Concept Technology Demonstration web page. It begins with an introduction to ACTDs, transitions to the focus of the program and the criterion used to evaluate proposed ACTDs, and then concludes by describing the four ACTD objectives.

a. Introduction to ACTDs

In early 1994, the DoD initiated a new program designed to help expedite the transition of maturing technologies from developers to the users. The Advanced Concept Technology Demonstration (ACTD) program was to help the DoD acquisition process adapt to today's economic and threat environments. ACTDs emphasize technology assessment and integration rather than technology development. The goal is to provide a prototype capability to the warfighter and to support him in the evaluation of that capability. The warfighters evaluate the capabilities in real military exercises and at a scale sufficient to fully assess military utility.

ACTDs are designed to allow users to gain an understanding of proposed new capabilities for which there is no user experience base. Specifically, they provide the warfighter an opportunity: to develop and refine his concept of operations to fully exploit the capability under evaluation, to evolve his operational requirements as he gains experience and understanding of the capability, and to operate militarily useful quantities of prototype systems in realistic military demonstrations, and on that basis, make an assessment of the military utility of the proposed capability.

⁷⁹ The information in this section is an excerpt from the Advanced Technology Concept Demonstration Home Page, <http://www.acq.osd.mil/actd/intro.htm#Introduction>, [20 April 2005]

At the conclusion of the ACTD operational demonstration, there are three potential outcomes. The user sponsor may recommend acquisition of the technology and fielding of the residual capability that remains at the completion of the demonstration phase of the ACTD to provide an interim and limited operational capability. If the capability or system does not demonstrate military utility, the project is terminated or returned to the technology base. A third possibility is that the user's need is fully satisfied by fielding the residual capability that remains at the conclusion of the ACTD, and there is no need to acquire additional units.

b. Focus of ACTDs⁸⁰

There are several key criteria by which ACTD candidates are evaluated: response to user needs, maturity of technologies, and potential effectiveness.

(1) User needs: ACTDs focus on addressing critical military needs. To evaluate proposed solutions to meet these needs, intense user involvement is required. ACTDs place mature technologies in the hands of the user and then conduct realistic and extensive military exercises to provide the user an opportunity to evaluate utility and gain experience with the capability. The process provides the users a basis for evaluating and refining their operational requirements, for developing a corresponding concept of operations, and ultimately for developing a sound understanding of the military utility of the proposed solution before a decision is made to enter into the formal acquisition process. Furthermore, a key objective of ACTDs is to provide a residual operational capability for the warfighter as an interim solution prior to procurement.

(2) Exploit mature technologies: ACTDs are based on mature or nearly mature technologies. By limiting consideration to mature technologies, the ACTD avoids the time and risks associated with technology development, concentrating instead on integration and demonstration activities. This approach permits an early user demonstration on a greatly reduced schedule at a reduced cost.

(3) Potential effectiveness: The potential or projected effectiveness must be sufficient to warrant consideration of an ACTD or the capability must address a need for which there is no suitable solution.

These are the criteria used by the Deputy Under Secretary of Defense for Advanced Systems and Concepts (DUSD(AS&C)) as an initial filter in the ACTD review process. The ACTDs that pass this step are then subjected

⁸⁰ The information in this section is an excerpt from the Advanced Technology Concept Demonstration Home Page, <http://www.acq.osd.mil/actd/intro.htm#Introduction>, [20 April 2005]

to an in-depth review by Service, Agency, and Joint Staff technical and operational personnel.

c. ACTD Objectives

The objectives of an ACTD are to conduct meaningful demonstrations of the capability, develop and test concepts of operations to optimize military effectiveness, and prepare to transition the capability into acquisition without loss of momentum, if warranted.

(1) **Conduct meaningful demonstrations of the capability:** The demonstrations are sized and structured to provide clear evaluation of military capability. The user, with support from the Operational Test Agencies, defines the measures of effectiveness and measures of performance that allow effectiveness and suitability to be characterized. Data collection is tailored accordingly. The quantity of systems in the ACTD is sufficient to provide a valid assessment of the capability, or simulations are used to expand the battlespace and forces involved in the exercise. The user provides, or at least approves, the planned operational exercises which typically include red, as well as blue, forces.

(2) **Concept of operations (CONOPS):** Many of the ACTDs are based on advanced technologies which may permit, or even demand, new CONOPS, tactics, and doctrine in order to realize their maximum potential. The ACTD provides a means to develop, refine, and optimize these warfighting concepts to achieve maximum utility and effectiveness.

(3) **Prepare to transition into acquisition:** A key goal of ACTDs is to move into the appropriate phase of formal acquisition without loss of momentum, assuming the user makes a positive determination of military utility. Each ACTD has a clear acquisition goal for the post ACTD phases. In addition, there must be provisions for the development of formal operational requirements; documents addressing interoperability, life cycle cost, manning, and training; and preparations for supportability.

(4) **Management Oversight:** Each ACTD is managed by a lead Service or Agency developer and driven by the principal user sponsor. As a general rule, but not as a requirement, the user sponsor is usually a Unified Commander. The Joint Requirements Oversight Council (JROC) will make a recommendation to the DUSD(AS&C) regarding the lead Service and user sponsor as part of the JROC review of candidate ACTDs. All user and development organizations are represented on an oversight group, chaired by the DUSD(AS&C). The purpose of this group of senior representatives is to provide a decision making body that can respond quickly to significant program issues that require management direction or approval and to assure effective, timely communications among the leadership level of the key participating organizations.

THIS PAGE INTENTIONALLY LEFT BLANK

IV. ANALYSIS

A. INTRODUCTION

In this chapter, we present our analysis of the data presented in Chapter III. To facilitate an easy crosswalk between the data and analysis, we used the same format for Chapters III and IV. We begin with the analysis of the test results for each PVPC product test in Section B. In Section C, we correlate the product description and type of product tests with the different Technology Readiness Levels. Finally, we apply the definitions of the DOD Technology Insertion Methods to the PVPC.

B. PRODUCT TEST ANALYSIS

The purpose of our Product Test Analysis is to present our study of the individual PVPC test data collected during our research. The ultimate goal of our analysis is to document clear and logical interpretations of factual data that will allow us to conclude whether or not a solar power system integrated with the PVPC generates more power. We categorized the tests into three sections. The first section details the analyses of the tests conducted by Atira, the second section covers test conducted at NPS, and the third section discusses test conducted by Raven Designs. The presentation order of the analysis does not reflect the chronological order of the tests conducted.

We used conventional and automated analytical tools to extract information from the test data. For each test, we provide a brief narrative that describes these descriptive statistics and support the narrative using tabular and graphical techniques to provide further clarity. Following our individual analysis, we then review our individual interpretations to identify any correlations and/or consistencies between the individual tests that may support overall or summary conclusions about the performance of the PVPC technology.

1. Atira Technologies Comparison Test

The test approach used was a side-by-side comparison of solar power systems using procedures that measured the PVPC's performance levels. Each test consisted of testing two identically configured systems except one system integrated the PVPC technology. For simplicity, the solar power system integrated with the PVPC is referred

to as the “PVPC system” and the solar power system without the PVPC is referred to as the “Standard system”. Our analysis focuses on two data elements, current (mA) and power (Watts). These two data elements are the best indicators of the amount of energy a system is generating at a specific point in time. Current is the primary measurable output from each solar power system while power is a product of the load source (Volts) and the current. For our analysis, we use power as the standard measurement to allow us to compare results consistently from tests that have varied input, and in some cases load variables. For each test, we entered the collected data into an automated spreadsheet and used the software to generate the descriptive statistics and graphic depictions for the data. This allowed us to identify any significant and measurable differences.

a. Atira LM-3 Test with 12V Load

Atira Tech used the Uni-Solar LM-3 modules and UBC36106102/PCM Ultra-Life Polymer 3.7V Rechargeable batteries for this test. For each system, Atira representatives wired three Ultra-Life Polymer batteries, in series, to represent a 12V battery load. Atira selected the 12V battery to demonstrate specifically the ability of the PVPC to enhance or improve an existing solar power system. Uni-Solar designed the LM-3 Module to charge a 9V battery. As explained previously, if the system cannot convert enough solar power into electrical power with the right characteristics to reach the batteries charging threshold, the power generated is lost or unusable. Because Uni-Solar designed the LM-3 to charge a 9V battery, it does not generate enough usable power to charge a 12V battery. With this in mind, Atira wanted to demonstrate that by incorporating the PVPC into the solar charging system, it could access the energy that is produced below battery charging thresholds and transform it to generate usable power to charge a battery beyond the LM3’s designed charging threshold.

The time interval for the test was approximately 10 hours beginning at 0730 and ending at 1730. Atira recorded 18 data readings during the test period. Table 11 presents the descriptive statistics for battery current (mA), battery voltage (V), and power (mW).

Table 11. LM-3 12V Test Descriptive Statistics

LM-3 12V Test (Feb 8)						
	Battery Current (mA)		Watts (mW)		Battery Voltage (V)	
	Standard	PVPC	Standard	PVPC	Standard	PVPC
Mean	18.06	52.67	206.38	614.32	11.43	11.67
Median	10.00	50.00	114.30	586.50	11.43	11.68
Range	50.00	100.00	571.50	1169.00	0.00	0.14
Minimum	0.00	0.00	0.00	0.00	11.43	11.59
Maximum	50.00	100.00	571.50	1169.00	11.43	11.73
Sum	325.00	948.00	3714.75	11057.82	205.74	209.99
Count	18	18	18	18	18	18

Beginning with battery current, we review and compare the statistics for each data element. By examining the Mean, we can compare the averages for each solar power system. The average Battery Currents for the Standard and PVPC systems are 18.06 and 52.67 respectively. The numerical difference between the two means is approximately 34.6 mA. Dividing the difference of 34.6 by the mean of the Standard system, reveals a percentage difference of approximately 191%. The minimum mA reading for each system was 0.00mA. The maximum mA reading for the PVPC system was 100mA, which is exactly double the 50mA maximum reading recorded for the Standard system.

The descriptive statistics also provides the sum for each of the data points. It is important to understand that the sum is only the cumulative amount of 18 (count) data recordings or samples and that each recording represents a particular point in time. The sum does not reflect the total cumulative amount generated by either system during the entire test period. Observing the mA sum for each system, we determine that for the 18 data recordings, the Standard system accumulated 325mA and the PVPC 948mA for a difference of 623mA or 191%.

Using the same methodology as above, we can compare the descriptive statistics for the data for power (mW). The mW range for the Standard system is 571mW with a minimum recording of 0.00mW and a maximum of 571.50mW. The PVPC demonstrated a range of 0.00mW to a much higher maximum of 1,169.00mW. On average, the Standard system generated 206.38mW and the PVPC generated an average

of 614.32mW for a difference of 407.94mW or approximately 197%. The sum for each system is 3,714.75mW for the Standard and 11,057.82mW for the PVPC. This translates to a difference of 7,343.07mW, or approximately 197%, and correlates directly to the percent increase in average power. The reason the percentage differences in current and power are not exactly the same is because each system started with a slightly different voltage

The beginning charge for the standard system was 11.43Vs, while the PVPC system measured 11.67V. Both systems were below the fully discharged threshold for the battery configuration. At the conclusion of the test, the standard system's battery charge remained the same at 11.43V. In contrast, the PVPC system's battery contained a charge of 11.73. The ranges for the standard system and the PVPC system were 0.0 and 0.14V respectively, thus the PVPC system increased the charge of the battery while the standard system failed to increase the charge.

A closer examination of the Voltage readings for the PVPC system (Table 12) revealed that the PVPC system generated enough power to charge the battery during the time interval between 0915hrs and 1345hrs. From 0830 through 1430 hours, the Standard system does produce power, however, as shown by the fact that the battery was not charging, none of it is usable. This reveals a key fact to which we have already alluded – not all power is usable power. In this situation, the PVPC system is essentially producing infinitely more power; however, we were unable to devise a method to quantify this advantage as both systems produce power, but only the PVPC system produced usable power.

Table 12. LM3 12V Test PVPC Charging Interval

LM3 12V Test (Feb 8)						
Time	Standard System			PVPC System		
	mA	V	Watts	mA	V	Watts
0730	0	11.43	0	0	11.59	0
0800	0	11.43	0	4	11.59	46.36
0830	10	11.43	114.3	4	11.59	46.36
0845	25	11.43	285.75	40	11.59	463.6
0915	50	11.43	571.5	100	11.59	1159
0920	50	11.43	571.5	100	11.60	1160
1000	50	11.43	571.5	100	11.59	1159
1200	50	11.43	571.5	100	11.66	1166
1245	10	11.43	114.3	50	11.66	583
1315	50	11.43	571.5	100	11.69	1169
1345	20	11.43	228.6	75	11.73	879.75
1430	10	11.43	114.3	75	11.73	879.75
1515	0	11.43	0	50	11.73	586.5
1545	0	11.43	0	50	11.73	586.5
1615	0	11.43	0	50	11.73	586.5
1645	0	11.43	0	50	11.73	586.5
1715	0	11.43	0	0	11.73	0
1716	0	11.43	0	0	11.73	0

For further analysis, we used graphs to compare visually the data collected for both systems. The first graph (Figure 10) graphically depicts the data collected for current versus time and the second graph (Figure 11) depicts power versus time. The third graph (Figure 12) combines both current and power versus time with the current axis displayed on the left and the power axis displayed on the right.

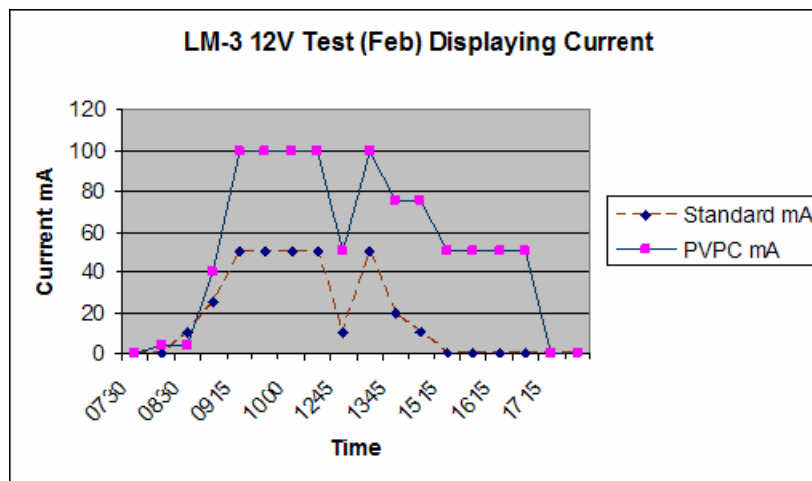

Figure 10. LM-3 12V Test mA Comparison Graph

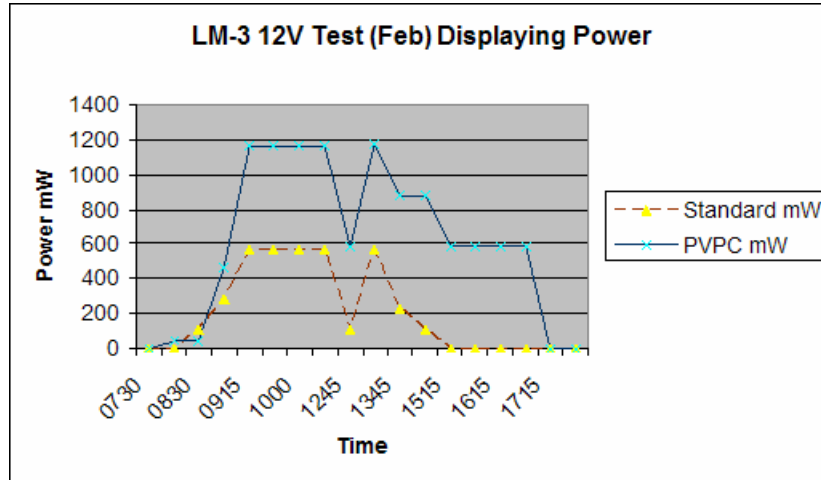

Figure 11. LM-3 12V Test mW Comparison Graph

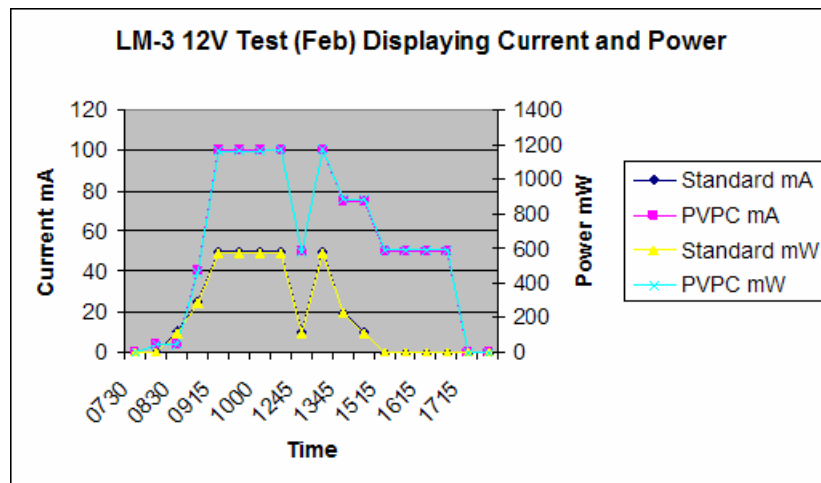

Figure 12. LM-3 12V Test mA and mW Combined Comparison Graph

At first glance, it appears that Figure 13 only depicts two data elements, yet the legend lists all four data elements. Actually, all four data elements are displayed, however, the current and power for each system follow identical relative paths. To explain further, power, as mentioned above, is a product of current and voltage. Second, the relative numerical differences between the voltage readings for each battery are very small. Third, the recorded times of the data samples are the same. As a result, current and power are directly correlated and although their numerical measurements are

different, the relative intervals with relation to the x-axis are identical. With this in mind, we will only use the graphs depicting power for the remainder of our comparison analysis.

As stated above, Figure 12 graphically depicts the data collected for power as measured in mW versus time. As expected, these graphics are consistent with the analysis of the descriptive statistics discussed previously. By starting at the left, we see that each system begins at 0730 with 0.00 mW generated, but by 0845, the PVPC system is producing nearly twice the power generated by the standard system. By 0915, both systems have reached their maximum power output and at maximum output, the PVPC system continues to produce twice as much power as the standard system.

Continuing along the data line for each system, we note a sudden drop in power for the data recorded at 1245hrs. Atira recorded that a brief period of cloud cover degraded the light conditions, which in turn caused the sudden reduction in power. Of key interest is the comparison of the two readings during the low light condition. Under the severely degraded light conditions, the power output for the standard system dropped by 80% from 571mW to 114mW. In contrast, the PVPC system's drop in power was only 50% from 1166mW to 583mW. Further, in these low light conditions, the PVPC system generated more power (583mW) than the maximum power output recorded for the Standard system (571mW) during the entire test period. Finally, the graph also highlights that the PVPC system continued to produce 586.5mW power for approximately an hour and a half after the Standard system ceased producing power.

b. Atira LM-3 Test with Programmable Fixed Load

Atira Tech used the Uni-Solar LM-3 modules and the HP 6063B DC Programmable Electronic Load system for this test. The test approach was a side-by-side comparison test. As pointed out in the introduction, these tests were chronologically the last tests conducted. Atira conducted the Programmable Fixed Load (PFL) tests to eliminate any concerns or perceptions that the slight variability in the beginning battery voltage significantly skewed the results. In the battery tests, the batteries were discharged, approximating a fully discharged level, however, identical initial battery charge states were not achieved. Although the differences were negligible and do not

significantly alter the results, initiating the trials with different charge states did introduce an undesirable, though slight variation.

The HP 6063B is a programmable DC load bank that is used to apply a consistent and specific load source to the test systems simultaneously. The goal of the test was to measure the power output of the Standard system and the PVPC system under identical conditions. Using the HP 6063B, Atira began with a minimum load of 0.5V and incrementally increased the loads by 0.5V until they reached a maximum load of 16.5V for each system. For this test, Atira integrated a 0916 PVPC circuit board. Table 13 presents the descriptive statistics for this test.

For the analysis of this test, we integrated the actual differences between each system, and the corresponding percentages, into the descriptive statistics table. The same methods and calculations describe in the previous section were used to determine these differences and percentages depicted.

Table 13. LM-3 w/ Programmable Fixed Load Test Descriptive Statistics

LM-3 Flex Test w/ Programmable Fixed Load								
	Battery Current (mA)				Watts (mW)			
	Standard	PVPC	Diff	% Diff	Standard	PVPC	Diff	% Diff
Mean	127.27	213.94	86.67	68.10%	707.73	1102.88	395.15	55.83%
Range	210.00	790.00	580.00	276.19%	1620.00	1305.00	-315.00	-19.44%
Minimum	0.00	0.00	0.00	0.00%	0.00	0.00	0.00	0.00%
Maximum	210.00	790.00	580.00	276.19%	1620.00	1305.00	-315.00	-19.44%
Sum	4200.00	7060.00	2860.00	68.10%	23355.00	36395.00	13040.00	55.83%
Count	33.00	33.00			33.00	33.00		

On average, the PVPC system generated 55% more power than the Standard system; however, in contrast to the previous test, the Standard system demonstrated a higher maximum power output at 1620mW compared to PVPC system's maximum output of 1305mW. We reviewed the data for the test and discovered that at loads between 7 and 10.5V, (Table 14) the Standard system produced more power than the PVPC; however, at all other loads the PVPC produced more power.

Table 14. LM-3 Flex Test w/ Programmable Fixed Load Excerpt

LM-3 Flex Test w/ Programmable Fixed Load					
System without PVPC			System with PVPC		
Voltage (V)	Current (mA)	Watts (mW)	Voltage (V)	Current (mA)	Watts (mW)
7	190	1330	7	170	1190
7.5	190	1425	7.5	160	1200
8	190	1520	8	150	1200
8.5	180	1530	8.5	150	1275
9	180	1620	9	140	1260
9.5	170	1615	9.5	130	1235
10	160	1600	10	120	1200
10.5	140	1470	10.5	120	1260

As detailed in Chapter III, the original PVPC circuit, the 1216, was designed to work with the 12V Solengy glass panel. Atira subsequently modified the 1216 into the 0916 model to work with the 9V Uni-Solar LM-3 panel in order to demonstrate that the PVPC could enable a solar charging system to perform beyond its designed capabilities. Thus, Atira performed the modification as a proof of concept to demonstrate that the 0916 PVPC, a 9V panel could indeed charge a 12V battery. Simply put, the 0916 PVPC circuit was never specifically designed to optimize at the LM-3s 9V input level, which likely accounts for the Standard system generating more power at voltage levels between 7V and 10.5V.

For further analysis, we used a graph to visually depict the data collected for both systems. Figure 13 presents the data for battery current and power versus the volts or load placed on the system. The Y-axis on the left represents the battery current mA and the Y-axis on the right represents the power mWs, while the X-axis depicts the load (V). This graphically depicts that although the Standard system produced more power at voltage loads between 7V and 10.5V, overall the PVPC produced 55% more power.

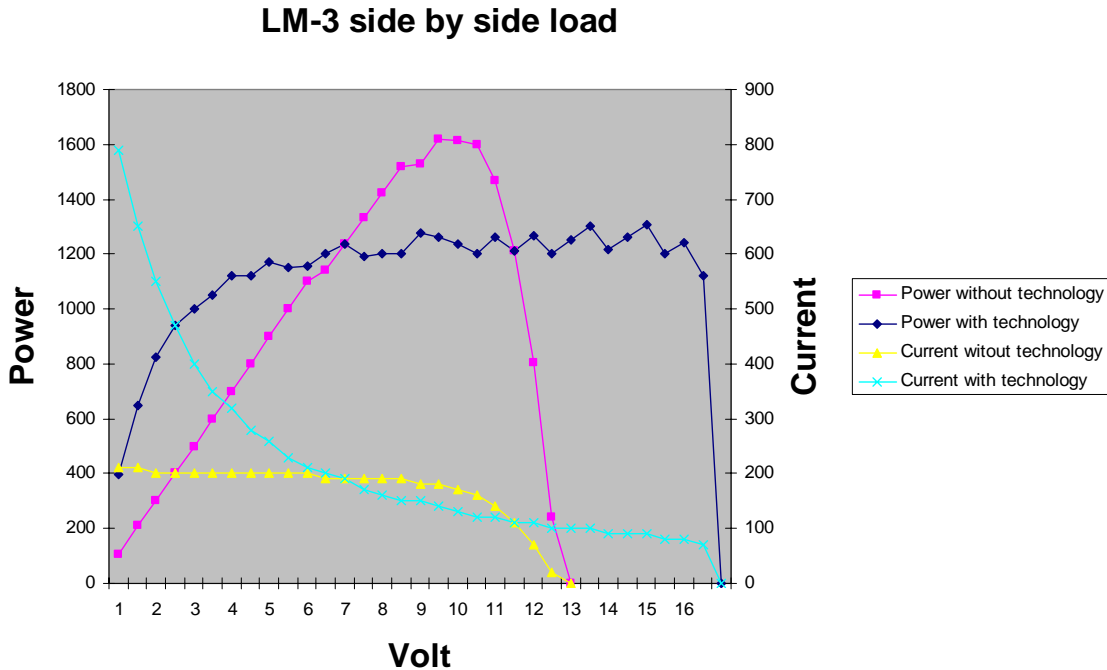

Figure 13. LM-3 Variable Fixed Load Test Graphics

c. Atira P-4 Test with Programmable Fixed Load

Atira Tech used the Global Solar P-4 modules and the HP 6063B for this test. The goal of the test was to measure the power output of the Standard system and the PVPC system under identical conditions. Using the HP 6063B, Atira began with a minimum load of 0.5V and incrementally increased the loads by 0.5V until they reached a maximum load of 16.5V for each system. In contrast to the LM-3 Programmable Load test in section b. above, the 0516 PVPC circuits were specifically designed to optimize a set of three Global Solar P-4 Modules. Table 15 presents the descriptive statistics for this test.

For the analysis of this test, we integrated the actual differences between each system, and the corresponding percentages, into the descriptive statistics table. The same methods and calculations describe in the previous section were used to determine these differences and percentages depicted.

Table 15. Global Solar P-4 Test with Programmable Fixed Load Descriptive Statistics

Global Solar P-4 Test with Programmable Fixed Load								
	Battery Current (mA)				Watts (mW)			
	Standard	PVPC	Diff	% Diff	Standard	PVPC	Diff	% Diff
Mean	1002.12	1900.30	898.18	89.63%	10481.89	14597.00	4115.11	39.26%
Range	1890.00	9270.00	7380.00	390.48%	19620.00	21605.00	1985.00	10.12%
Minimum	0.00	0.00	0.00	0.00%	0.00	0.00	0.00	0.00%
Maximum	1890.00	9270.00	7380.00	390.48%	19620.00	21605.00	1985.00	10.12%
Sum	66140.00	125420.00	59280.00	89.63%	691805.00	963402.00	271597.00	39.26%
Count	66.00	66.00			66.00	66.00		

On average, the PVPC system generated 39.26% more power than the Standard system and demonstrated a 10.12% higher maximum power output at 21,605mW compared to Standard system’s maximum output of 19,620mW. Observing the mW sum for each system, we determine that for the 66 data recordings, the Standard system accumulated 691,805mW and the PVPC 963,402mW for a difference of 271,597mW or 39.26%. For further analysis, we used a graph (Figure 14) to compare the data collected for both systems. For this test, Atira specifically designed PVPC technology to optimize the Global Solar P-4 module; thus, in contrast to the LM-3 Programmable Fixed Load Test, the PVPC system generated more mW than the Standard system throughout.

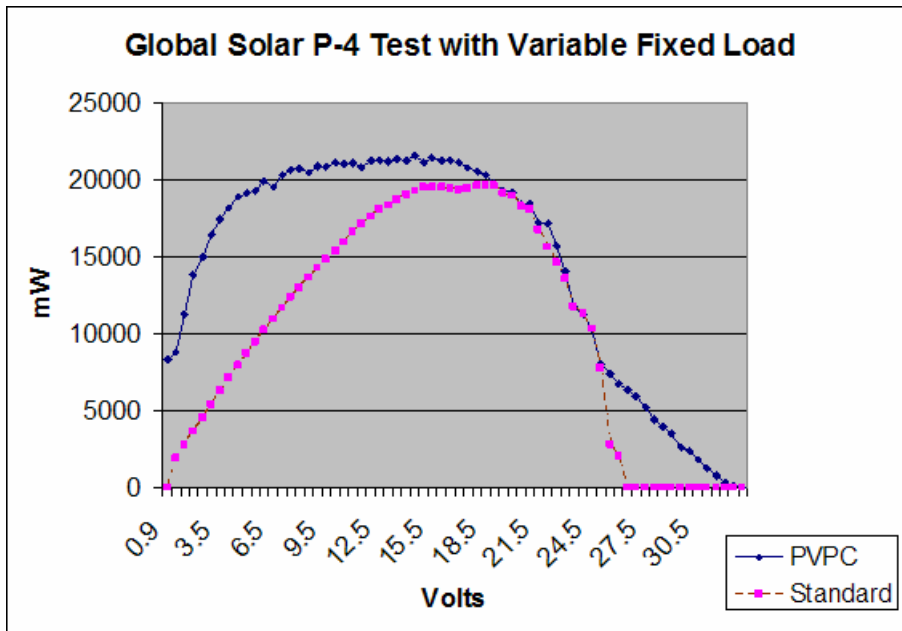

Figure 14. Global Solar P-4 with Variable Fixed Load Graphics

2. NPS Field Tests

We independently tested the PVPC April 6-11, 2005. Our objective was to validate the tests conducted by Atira Technologies and to verify that a solar power system integrated with the PVPC technology would produce more power than an identical system without the technology. The test approach used was a side-by-side comparison of solar power systems using procedures that measured the PVPC's performance levels. We conducted the tests in the uncontrolled, natural environment that existed on the scheduled test days with the intention of capturing performance data relevant to a typical temperate climate. Again, our analysis focuses on two data elements, current (mA) and power (Watts). As previously shown, we use power as the standard measurement to base our comparison. For each test, we entered the collected data into a Microsoft Excel spreadsheet and used the software to generate the descriptive statistics and graphic depictions for the data, which allowed us to identify any significant and measurable differences.

a. Glass Panel-7.4V Battery Field Performance Test

The solar panels used for the glass panel 7.4V tests were Solengy ASI-F 5/12 framed solar modules. The batteries used were UBC36106102/PCM Ultra-Life Polymer 3.7V Rechargeable batteries. For each system, we wired two of these batteries in series to create a 7.4V battery load for glass tests 1-3. The PVPC circuit was a model 1216. Table 16 presents the descriptive statistics for Glass Panel Tests 1 through 3.

For the analysis of this test, we integrated the actual differences between each system, and the corresponding percentages, into the descriptive statistics table. The same methods and calculations describe in the previous sections were used to determine these differences and percentages depicted.

Table 16. Glass Test 1-3 Descriptive Statistics

Glass Test 1-3 With 7.4V Battery (6 April 05)								
	Battery Current (mA)				Watts (mW)			
	Standard	PVPC	Diff	% of Diff	Standard	PVPC	Diff	% of Diff
Mean	182.64	254.23	71.59	39.20%	1406.33	1986.61	580.28	41.26%
Range	407.00	535.00	128.00	31.45%	3015.69	4028.55	1012.86	33.59%
Minimum	2.00	0.00	-2.00	-100.00%	15.00	0.00	-15.00	-100.00%
Maximum	409.00	535.00	126.00	30.81%	3030.69	4028.55	997.86	32.93%
Sum	10228.00	14237.00	4009.00	39.20%	78754.42	111250.06	32495.64	41.26%
Count	56.00	56.00	0.00	0.00%	56.00	56.00	0.00	0.00%

On average, the PVPC system generated 41% more power than the Standard system and demonstrated a 32.93% higher maximum power output at 4,028.55mW compared to the Standard system's maximum output of 3,030.69mW. Observing the mW sum for each system, we determine that for the 56 data recordings, the Standard system accumulated 78,754.42mW and the PVPC 111,250.06mW for a difference of 32,495.64mW or 41.26%. For further analysis, we used graphs to visually compare the data collected for both systems. Due to the different time intervals for each test, we present individual graphics depicting power versus time (Figures 15-17). For all three tests, the PVPC system generated more mW than the Standard system.

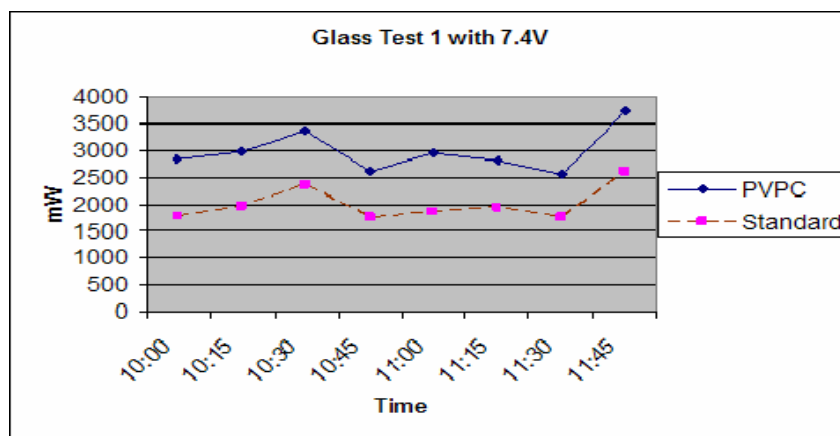

Figure 15. Glass Test 1: 7.4V mW Comparison Graph

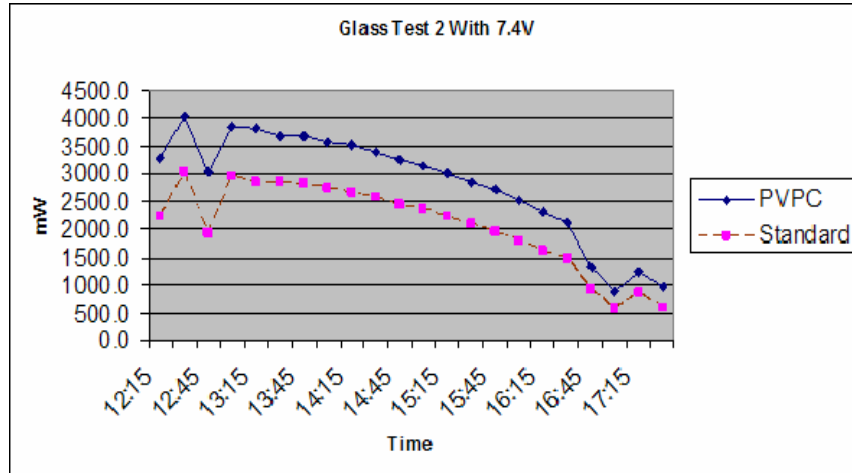

Figure 16. Glass Test 2: 7.4V mW Comparison Graph

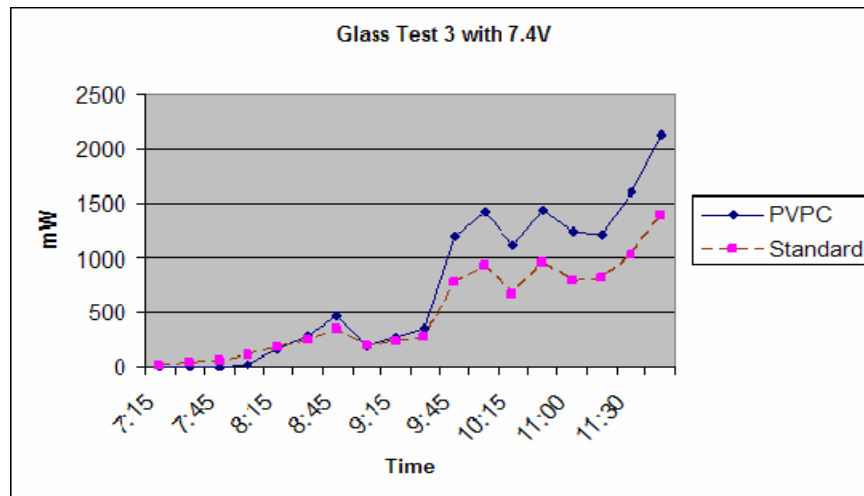

Figure 17. Glass Test 3 7.4V mW Comparison Graph

b. Glass Panel –3.7V Battery Field Performance Test

We conducted a single iteration of this test. The solar panels used were Solengy ASI-F 5/12 framed solar modules. The batteries used were UBC36106102/PCM Ultra-Life Polymer 3.7V Rechargeable. To test the system under a different load source, we intentionally wired two of these batteries in parallel to create a 3.7V battery load. The 1216 PVPC circuit was used. Table 17 presents the descriptive statistics for the Glass Panel Test with a 3.7V.

Table 17. Glass Test 4 Descriptive Statistics

Glass Test 4 With 3.7V Battery (10 April 05)								
	Battery Current (mA)				Watts (mW)			
	Standard	PVPC	Diff	% of Diff	Standard	PVPC	Diff	% of Diff
Mean	206.87	308.13	101.27	48.95%	796.49	1188.55	392.06	49.22%
Median	240.50	380.50	140.00	58.21%	917.56	1458.32	540.76	58.94%
Range	368.00	522.00	154.00	41.85%	1427.84	2030.08	602.24	42.18%
Minimum	0.00	0.00	0.00	0.00%	0.00	0.00	0.00	0.00%
Maximum	368.00	522.00	154.00	41.85%	1427.84	2030.08	602.24	42.18%
Sum	6206.00	9244.00	3038.00	48.95%	23894.78	35656.56	11761.78	49.22%
Count	30.00	30.00	0.00	0.00%	30.00	30.00	0.00	0.00%

On average, the PVPC system generated 49.22% more power than the Standard system and demonstrated a 42.18% higher maximum power output at 2,030.08mW compared to Standard system's maximum output of 1,427.84mW. Observing the mW sum for each system, we determine that for the 30 data recordings, the Standard system accumulated 23,894.78mW and the PVPC accumulated 35,656.56mW, for a difference of 11,761.784mW or 49.22%. For further analysis, we present a graph to compare the data collected for both systems. Figure 18 illustrates that the PVPC system generated more mW than the Standard system throughout the test.

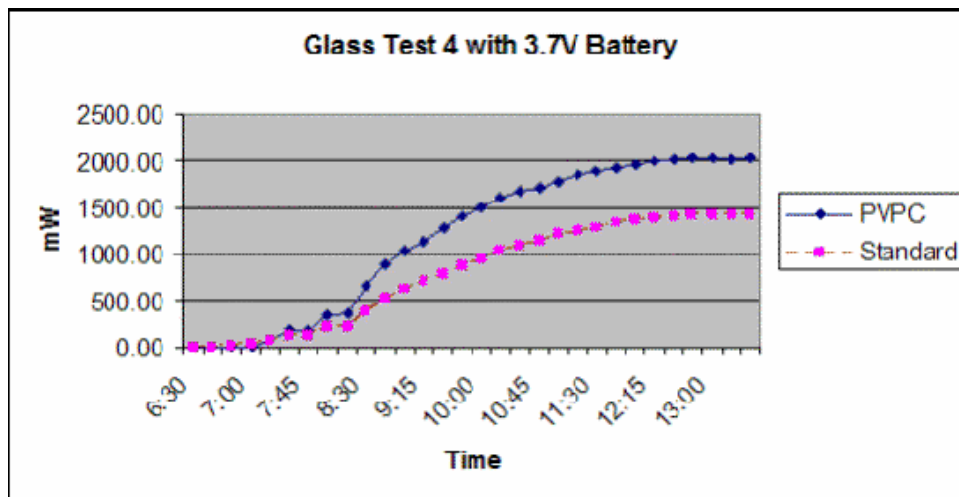

Figure 18. Glass Test 4 3.7V mW Comparison Graph

c. Flexible Panel-7.4V Battery Field Performance Test

We conducted a single iteration of this test. The solar panels used for the flexible panel 7.4V tests were Uni-Solar LM-3 modules. Each system utilized an array of three LM-3 modules. The batteries used were UBC36106102/PCM Ultra-Life Polymer 3.7V Rechargeable batteries with two batteries wired in series to create a 7.4V battery load. The PVPC technology circuit board used was a model 0916. Table 18 presents the descriptive statistics for this test.

Table 18. Flex Test 7.4V Battery Descriptive Statistics

Flex Test With 7.4V Battery (10 April 05)								
	Battery Current (mA)				Watts (mW)			
	Standard	PVPC	Diff	% of Diff	W/out	W/ PVPC	Diff	% of Diff
Mean	794.38	636.75	-157.63	-19.84%	6383.36	4984.17	-1399.18	-21.92%
Median	811.50	644.50	-167.00	-20.58%	6605.20	5081.98	-1523.22	-23.06%
Range	87.00	55.00	-32.00	-36.78%	957.19	693.13	-264.06	-27.59%
Minimum	738.00	604.00	-134.00	-18.16%	5742.03	4572.28	-1169.75	-20.37%
Maximum	825.00	659.00	-166.00	-20.12%	6699.22	5265.41	-1433.81	-21.40%
Sum	6355.00	5094.00	-1261.00	-19.84%	51066.84	39873.39	-11193.45	-21.92%
Count	8.00	8.00	0.00	0.00%	8.00	8.00	0.00	0.00%

On average, the PVPC system generated 21.92% less power than the Standard system and demonstrated a 21.40% lower maximum power output at 5,265.41mW compared to Standard system’s maximum output of 6,699.22mW. Observing the mA sum for each system, we determine that for the eight data recordings, the Standard system accumulated 51,066.84mW and the PVPC accumulated 39,873.39mW for a difference of 11,193.45mW or 21.92%. For further analysis, we present a graph to compare the data collected for both systems. Figure 19 illustrates that the standard system generated more power than the PVPC system throughout the test.

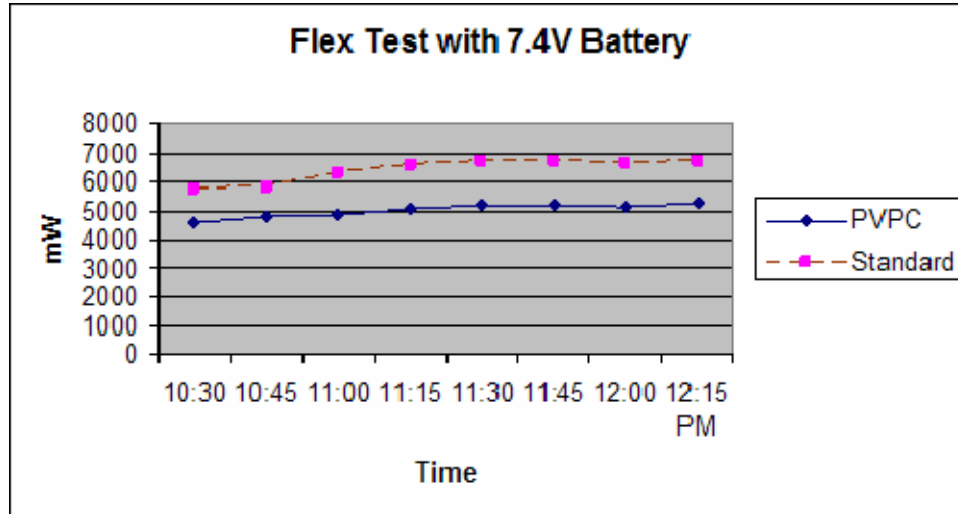

Figure 19. Flex Test with 7.4V Battery Field Test

The results of this test, having a battery charging range between 7V and 8.5V, directly correlates with the results from the Atira Programmable Fixed Load test for the LM-3. In the Atira test, the Standard system produced more power than the PVPC system at a voltage range between 7V and 10V. This confirmed that the modified 0916 Circuit did not optimize the PVPC system as expected

d. Flexible Panel-3.7V Battery Field Performance Test

We conducted a single iteration of this test. The solar panels used for the flexible panel 3.7V tests were Uni-Solar LM-3 modules. Each system utilized an array of three LM-3 modules. The batteries used were UBC36106102/PCM Ultra-Life Polymer 3.7V Rechargeable batteries. For each system, we wired two of these batteries in parallel to create a 3.7V battery load for the test. The PVPC circuit used was a model 1216. Presented below are the descriptive statistics for this test.

Table 19. Flexible Panel Test With 3.7V Battery Descriptive Statistics

Flex Test With 3.7V Battery (10 April 05)								
	Battery Current (mA)				Watts (mW)			
	Standard	PVPC	Diff	% Dif	Standard	PVPC	Diff	% Dif
Mean	275.69	358.50	82.81	30.04%	1102.42	1407.20	304.78	27.65%
Median	163.00	252.00	89.00	54.60%	629.18	965.16	335.98	53.40%
Range	725.00	855.00	130.00	17.93%	2972.50	3428.55	456.05	15.34%
Minimum	0.00	0.00	0.00	0.00%	0.00	0.00	0.00	0.00%
Maximum	725.00	855.00	130.00	17.93%	2972.50	3428.55	456.05	15.34%
Sum	4411.00	5736.00	1325.00	30.04%	17638.69	22515.20	4876.51	27.65%
Count	16.00	16.00	0.00	0.00%	16.00	16.00	0.00	0.00%

On average, the PVPC system generated 27.65% more power than the Standard system and demonstrated a 15.34% higher maximum power output at 3,428.55mW compared to Standard system's maximum output of 2,972.50mW. Observing the mA sum for each system, we determine that for the 16 data recordings, the Standard system accumulated 17,638.69mW and the PVPC 22,515.20mW for a difference of 4,876.51mW or 27.65%. For further analysis, we used a graph to compare the data collected for both systems. Figure 20 illustrates that the PVPC system generated more power than the standard system throughout the test.

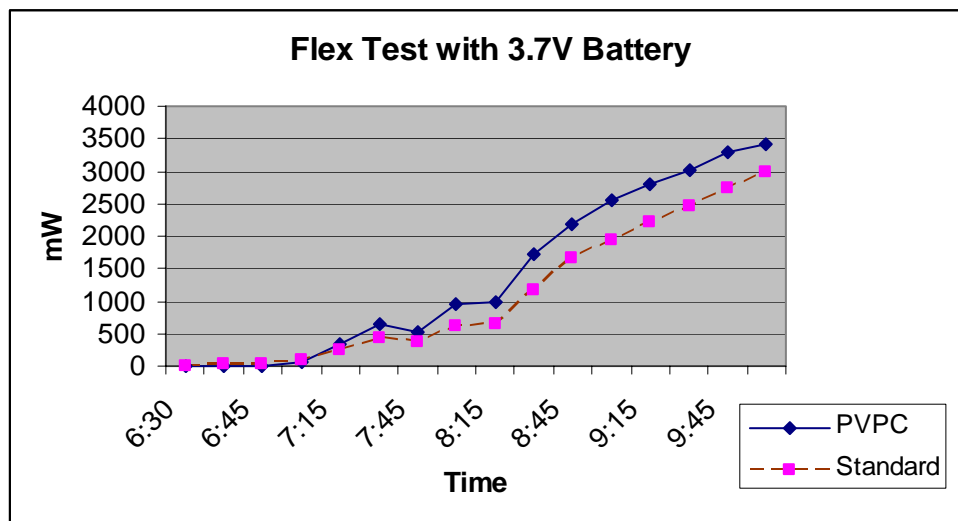

Figure 20. Flex Test with 3.7V Battery Field Test

3. Raven Designs Field Tests

Atira Technologies collaborated with Raven Designs to integrate the PVPC technology into one of newly developed solar charging products. Atira incorporated the technology into an SBR Solar Pack Cover. Raven Designs designed the SBR to recharge the UBI 2590 rechargeable battery, a battery used extensively by U.S. military forces.

During the first week of November 2004, Steve Locher, designer of the SBR, spent a week testing the product in Kodiak, Alaska. He conducted his test with U.S. Navy Seal Instructors at the Northern Warfare Training Center. Following the test conducted in Alaska, Mr. Locher conducted similar field-testing of the Solar Pack, with the integrated PVPC technology, in Monterey, CA.

The purpose of Mr. Locher's tests was to evaluate the performance of the SBR system in an operational environment. This test approach and objective is significantly different from the approaches and objectives of the previous product tests analyzed above. As indicated, the previous tests were side-by-side comparisons based on quantitative outputs to determine if the PVPC technology increases the power output of an existing system. In contrast, the objective of the Raven design tests was to determine if the SBR would recharge a UBI-2590 battery in an operational environment. As a result, our analysis of this test is more qualitative than quantitative.

Review of Mr. Locher's comments for the test conducted in Alaska reveals that the SBR system increased the charge of a UBI-2590 battery by approximately 26.6% over a nine-hour period. Further, the system increased the battery's charge in the low light conditions characteristic of Kodiak Alaska during the month of November. It is apparent that the SBR, with the PVPC, did function as intended; however, because we do not have a benchmark to evaluate the rate of charge, we are unable to determine the efficiency of the systems performance or the specific impact of the integrated PVPC technology.

In contrast to the low light conditions typical of a November day in Kodiak, Alaska, the light conditions were more favorable for the test conducted in Monterey, CA. Mr. Locher conducted in the Monterey test on a clear day during the last week of

November. During the Monterey test, the SBR increased the charge of the UBI-2590 battery by 71%. As above, it is apparent that the SBR integrated with the PVPC functioned successfully in an operational environment but once again, a benchmark is not available to determine the efficiency of the SBR or the PVPC.

4. Summary Analysis of Quantitative Product Tests

Overall, we analyzed and presented the results for seven individual tests using conventional and automated analytical tools to extract information from the test data. In this section, we review our individual analysis to identify any correlations and/or consistencies between the individual tests that may support overall or summary conclusions about the PVPC technology. To support a general conclusion or inference of whether or not a solar power system integrated with the PVPC generates more power, we will conduct a Difference between Two Means Test: Matched Pairs. To accomplish this we will first review the different tests and determine which tests, if any, are outliers and remove them accordingly from the analysis. Second, we will conduct the Matched Pairs test, and third, we analyze and interpret the results.

Outliers are data elements that may potentially skew the results of a statistical analysis. In our study, we exclude any test data set that was incorrectly included. To aid in identifying any outliers, we created Table 20 below. This table lists each test conducted and provides the average power for the Standard and PVPC systems, their numerical differences, and the percentage of differences based on the mean of the Standard system.

Table 20. Test Summary of Individual Tests

Test Summary by Individual Test (mW)				
Test	Standard	PVPC	Diff	% Diff
Atira LM-3 Flex Test w/ Variable Fixed Load	707.73	1102.88	395.15	55.83%
Atira LM3 12V Test	206.38	614.32	407.95	197.67%
Atira P-4 Test w/ Variable Fixed Load	10481.89	14597.00	4115.11	39.26%
Glass Test 1-3 w/ 7.4V Battery	1406.33	1986.61	580.28	41.26%
Glass Test 4 w/ 3.7V Battery	796.49	1188.55	392.06	49.22%
Flex Test w/ 7.4V Battery	6383.36	4984.17	-1399.18	-21.92%
Flex Test w/ 3.7V Battery	1102.42	1407.20	304.78	27.65%

During our analyses, we identified four tests that are potential outliers. The first test is the Atira 12V LM-3 12V Test. As illustrated in the table above, the PVPC system generated an average of 197% more power than the standard system. Although the numbers are accurate, this test data will inappropriately skew our results. As discussed in the individual analysis of the test, Atira did not specifically design the PVPC 0916 to operate at an optimal level with the Uni-Solar LM-3 module. Likewise, Uni-Solar did not design the LM-3 Module to charge a 12V battery. In fact, Atira had modified a 1216 to create the 0916 PVPC just to illustrate that the technology could enable the 9V, LM-3 array to operate outside of its design limits. In this regard, the test was a success; however, for our final analysis we will only include data from test scenarios that allow both systems to operate at their optimal design configurations. Therefore, the Atira LM-3 12V Test is classified as an outlier and is not included in our final data population. The second and third outliers, the Atira LM-3 Test w/ Programmable Fixed Load and Flex Test with 7.4V Battery, are not included in our final data population. We removed these tests from consideration for the same reasons stated above.

There was a fourth test that we considered a potential outlier; the Flex Test with 3.7V Battery. Like the proceeding test, this test was conducted using a non-optimized 0916 circuit with the 9V LM-3 modules; however, the relevant charging range and threshold of a 3.7V configuration, allowed both systems to operate as designed. Therefore, the Flex Test with 3.7V Battery is not classified as an outlier and is included in the final analysis.

Table 21 below depicts the tests removed from final analysis. The remaining test data represent test scenarios that allowed both systems to operated as optimally designed. By removing the outliers, we reduced the data sample from 229 to 170.

Table 21. Test Summary with Outliers Excluded

Test Summary by Individual Test w/ Exclusions				
Test	Standard	PVPC	Diff	% Diff
Atira LM-3 Flex Test w/ Variable Fixed Load				
Atira LM3 12V Test				
Atira P-4 Test w/ Variable Fixed Load	10481.89	14597.00	4115.11	39.26%
Glass Test 1-3 w/ 7.4V Battery	1406.33	1986.61	580.28	41.26%
Glass Test 4 w/ 3.7V Battery	796.49	1188.55	392.06	49.22%
Flex Test w/ 7.4V Battery				
Flex Test w/ 3.7V Battery	1102.42	1407.20	304.78	27.65%

The statistical test appropriate for our final analysis is the Difference between Two Means Test: Matched Pairs. This test is appropriate for side-by-side or matched pairs experiments. The purpose is to compare the means of two populations of interval data. The parameter is the difference between two means $S_1 - S_2$ (Where S_1 = the mean highest power generated by the PVPC System, and S_2 = the mean highest power generated by the Standard System). Because we want to determine whether the PVPC generates more power than the Standard system, the alternative hypothesis (H_1) specifies that S_1 is greater than S_2 . Our alternative hypothesis (H_1) and null hypothesis (H_0) are:

H_0 : $(S_1 - S_2) = 0$: The PVPC does not generate more power than the Standard system.

H_1 : $(S_1 - S_2) > 0$: The PVPC does generate more power than the Standard system

To conduct the test we used all the selected test data (170 observations) and ran a “t-Test: Paired Two- Sample for Means” in MS Excel. The results of the test are presented in Table 22.

Table 22. t-Test: Paired Two Sample for Means

t-Test: Paired Two Sample for Means		
	<i>Standard</i>	<i>PVPC</i>
Mean	4777.02	6663.67
Variance	43409537	61976023
Observations	170	170
Pearson Correlation	0.936341001	
Hypothesized Mean Difference	0	
df	169	
t Stat	-8.56312	
P(T<=t) one-tail	0.00000	
t Critical one-tail	1.65392	
P(T<=t) two-tail	0.00000	
t Critical two-tail	1.97410	

With a test statistic of -8.56 and a *p*-value of .0000, there is overwhelming evidence to infer that the PVPC System generates more power than the Standard System, that is, we reject our null hypothesis above. Next, we estimate the mean difference power output from the two systems with a 95% confidence interval. Table 23 depicts the results.

Table 23. Estimated Mean Difference

t-Estimate: Mean	
Mean	1886.65
Standard Deviation	2872.66
LCL	1451.71
UCL	2321.59

Based on statistical test results depicted in Tables 22 and 23, we estimate with a 95% confidence interval, that the mean power (mW) for the PVPC exceeds the mean power (mW) for the Standard system by an amount that lies between 1,451.71mW and 2,321.59mW as depicted as the LCL and UCL above. By dividing the Lower Control Limit and the Upper Control Limit in Table 23 by the mean of the Standard system in Table 22, we can state more simply that we estimate that the PVPC generates between 30.39% and 48.60% more power than the Standard system with point estimate of 39.49% more power.

C. TECHNOLOGY READINESS ASSESSMENT

As stated in Chapter II, Technology Readiness Levels are a consistent measurement to categorize the maturity level of a program's key technologies and provide a common language or reference to the science and technology community within the DoD. The purpose of this section is to correlate the product description and type of product tests for the PVPC with the appropriate Technology Readiness Level. To accomplish this we use a format similar to Chapter III, section D, except that item c. now presents supporting documentation specifically for the PVPC versus the general example provided earlier. Our process is to review the definition of each TRL, beginning with TRL 1, and correlate the appropriate supporting information from Chapters II, III and IV. We analyze each TRL consecutively until we are unable to submit the appropriate support information to justify a transition to the next TRL.

1. TRL 1: Basic Principles Observed and Reported

a. Description

TRL 1 is the lowest level of technology readiness. At this level, scientific research begins to be translated into applied research and development.

b. Required Supporting Information

Supporting information required includes published research that identifies the principles that underlie this technology. References must include who, where, and when.

c. PVPC Supporting Information

(1) The Cooperative Research and Development Agreement between the NPS and Atira Technologies identify the principles that underlie the PVPC technology, May 2004. Chapter I, page 19, Atira and NPS.

(2) The cited works of Alexander Wolf and David Besser identify and provide a detailed description of the principles that underlie the PVPC. Chapter III, section B, Product Description: Converting Solar Power.

2. TRL 2: Technology Concept and/or Application Formulated

a. Description

Invention begins at TRL 2. Once basic principles are observed, practical applications can be invented. At TRL 2 applications are speculative, and proof or detailed analysis to support the assumptions may be lacking.

b. Supporting Information

Supporting information for TRL 2 include publications or other references that outline the application being considered and that provide analysis to support the concept.

c. PVPC Supporting Information

Mr. Stefan Matan's personal account of his development of the mathematical model he used to develop the technology and the solar cube he created. Chapter I, page 16-17.

3. TRL 3: Analytical and Experimental Critical Function and/or Characteristic Proof of Concept

a. Description

TRL 3 is characterized by the initiation of active research and development that includes analytical studies and laboratory studies to physically validate analytical predictions of separate elements of the technology.

b. Supporting Information

Supporting information include results of laboratory tests performed to measure parameters of interest and comparison to analytical predictions for critical subsystems. References must include who, where, and when the tests and comparisons were performed.

c. PVPC Supporting Information

The cited works of Alexander Wolf and David Besser, as well as identifying and providing a detailed description of the principles that underlie the PVPC, also analyze the results of tests which indicate that the PVPC can increase the performance of a solar power system by as much as 25 percent. This claim is what initiated our investigation. Chapter III, section B, Product Description: Converting Solar Power.

4. TRL 4: Component and/or Breadboard Validation in a Laboratory Environment

a. Description

At level TRL 4 basic technological components are integrated to establish that they will work together. This is relatively ‘low fidelity’ compared to the eventual system.

b. Supporting Information

Supporting information necessarily includes system concepts that have been considered and results from testing laboratory-scale breadboard(s). References must provide who, where, and when the tests and comparisons were performed.

c. PVPC Supporting Information

(1) Atira Technologies LM-3 Test with 12V Load conducted by Atira Technologies, 8 February 2005. Chapter III, page 37, Chapter IV, page 63.

(2) Atira Technologies LM-3 Test with Variable Fixed Load conducted by Atira Technologies, 20 February 2005. Chapter III, page 39, Chapter IV, page 69,80.

(3) Atira P-4 Test with Variable Fixed Load conducted by Atira Technologies, 25 April 2005. Chapter III, page 40, Chapter IV, page 70, 80

5. TRL 5: Component and/or Breadboard Validation in a Relevant Environment

a. Description

Fidelity of breadboard technology increases significantly at TRL 5. The basic technological components are integrated with reasonably realistic supporting elements so they can be tested in a simulated environment.

b. Supporting Information

Supporting information consist of results from testing a laboratory breadboard system that are integrated with other supporting elements in a simulated operational environment. Documentation should address questions such as, how the relevant environment differs from the expected operational environment; how do the test results compare with expectations; what problems, if any, were encountered; was the breadboard system refined to match the expected system goals more nearly?

c. PVPC Supporting Information

(1) NPS, Glass Panel 7.4V Battery Field Performance Tests conducted by the authors, 6-10 April 2005, Chapter III, page 41-44, Chapter IV, page 73-74, 80

(2) NPS, Glass Panel 3.7V Battery Field Performance Test conducted by the authors, 10 April 2005, Chapter III, page 47, Chapter IV, page 77-78, 80.

(3) Raven Designs Field Tests conducted by Steve Locher November 2004, Lafayette, CA, Chapter III, page 48, Chapter IV, 78.

6. TRL 6: System/Subsystem Model or Prototype Demonstration in a Relevant Environment

a. Description

TRL 6 is characterized by a representative model or prototype system, which is well beyond that of TRL 5 that is tested in a relevant environment. This level represents a major step up in a technology's demonstrated readiness.

b. Supporting Information

Supporting information should consist of results from laboratory testing of a prototype system that is near the desired configuration in terms of performance, weight, and volume. Questions to address are how did the test environment differ from the operational environment? Who performed the tests? How did the test compare with expectations? What problems, if any, were encountered? What are/were the plans, options, or actions to resolve problems before moving to the next level?

c. PVPC Supporting Information

PVPC supporting information is not currently available to justify a transition to TRL 6.

D. DOD TECHNOLOGY INSERTION METHODS

1. Commercial Item

To begin our analysis, we restate the first part of the commercial item definition from the Commercial Item Handbook.

(a) Any item, other than real property, that is of a type customarily used by the general public or by nongovernmental entities for purposes other than governmental purposes, and that—

(1) Has been sold, leased, or licensed to the general public; or

(2) Has been offered for sale, lease, or license to the general public...⁸¹

a. *Establishing Commerciality*

By their very nature, photovoltaic systems, and their various components, are intended for use by the public. The capability to convert photons into electrical energy is not one that is solely desired by the Government. The PVPC is intended to make PV power systems more efficient and cost effective.

Drawing upon the description of the product in Chapter III, we recall that the PVPC is constructed from commercially available components. Also in Chapter III, we established that Atira sold the PVPC to Raven Designs, who has incorporated it into their solar charging products and offered it for sale to the public. This establishes that there have been both business-to-business sales and that the PVPC is being indirectly offered for sale to the general public. In Annex B, we provide a completed Commercial Item Checklist from the Commercial Item Handbook. Given the available evidence, the PVPC fully meets the commercial item definition.

b. *The Benefits of Commercial Item Classification*

Over the past decade, our government has been streamlining and transforming our federal acquisition policies and processes into a system that more closely resembles commercial industry standards or “best practices.” This transformation of the Federal Acquisition System has been characterized by three specific acts passed by Congress: the Federal Acquisition Streamlining Act of 1994 (FASA), the Federal Acquisition Reform Act of 1995 (FARA), and most recently the Service Acquisition Reform Act of 2003 (SARA). Before FASA emerged, the definition of a commercial

⁸¹ *Commercial Item Handbook*, Office of the Secretary of Defense, Acquisition, Technology and Logistics, November 2001, Appendix C

item was much more restrictive and it was a much more difficult process to get an item declared as commercial. All three of these acts emphasize the benefits of procuring “commercial items”.

J.S. Gansler, the former Under Secretary of Defense for Acquisition, Technology, and Logistics summarizes these benefits:

We must expand the use of commercial items in Department of Defense systems so we can leverage the massive technology investments of the private sector; reap the benefits of reduced cycle times, faster insertion of new technologies, lower life cycle costs, greater reliability and availability, and support from a robust industrial base. To accomplish this we must capitalize on the technical advances in the commercial marketplace by carefully reviewing our requirements to determine where they can be satisfied by commercially available products or where they can be altered to enable the Department to leverage the commercial sector.⁸²

The idea is that if private industry has identified the demand for a product, they will already be spending their money to develop it, make it reliable, and quickly get it to market so they can begin earning a profit. If DoD can use it, they may be able to acquire needed capabilities “better, faster and cheaper” than if they contracted for a developmental item. DoD will also reap the benefits of the economies of scale that the manufacturer enjoys when producing for a vastly larger population of users than just the Government. The marketplace drives the producer to reduce defects in the item and update the item with new, and increasing functionality and capabilities to maintain market share all at the producer’s expense – not the Government’s. There is also a less visible benefit to procuring a commercial item.

Even after a decade of acquisition reform, the process of doing business with the Government is so complicated and includes such a vast amount of burdensome laws and regulations that some firms simply refuse to participate when we send out a

⁸² J.S. Gansler, Memorandum as Forward to, Office of the Secretary of Defense Report on *Commercial Item Acquisition: Considerations and Lessons Learned*, (Washington D.C.: 2000).

request for proposal. For the firms that choose to do business with our Government, DoD in particular, the cost of complying with these regulatory and administrative burdens has been estimated.

In its December 1994 report, *The DOD Regulatory Cost Premium: A Quantitative Assessment*, [the consulting firm of] Coopers and Lybrand identified over 120 regulatory and statutory “cost drivers” that, according to the contractors surveyed, increase the price DOD pays for goods and services by 18 percent.⁸³

Table 24 below shows the top ten regulatory burdens and their estimated share of the total 18 percent compliance premium paid to contractors for doing business with the DoD. It also shows that these ten cost drivers account for almost 50 percent of the total DoD cost premium. If the costs associated with complying with these drivers still exist today and a determination of commerciality offered relief from some of the regulations, it would save the Government and industry both time and money.

⁸³ General Accounting Office, GAO/NSIAD-96-106, *Acquisition Reform: Efforts to Reduce the Cost to Manage and Oversee DOD Contracts*, (Washington, D.C.: 1996), 1.

Table 24. DoD Regulatory Compliance Costs: Top Ten Cost Drivers⁸⁴

Item #	Cost Driver	Coopers & Lybrand's Est Cost	Percent of Total 18%
1	MIL-Q-9858A	1.7%	9.4%
2	Truth in Negotiations Act (TINA)	1.3%	7.2%
3	Cost and Schedule Control System Requirements	0.9%	5.0%
4	Configuration Management	0.8%	4.4%
5	Contract Specific Requirements	0.7%	3.9%
6	Defense Contract Audit Agency (DCAA)/Defense Contract Management Agency (DCMA) Interface Requirements	0.7%	3.9%
7	Cost Accounting Standards (CAS)	0.7%	3.9%
8	Material Management and Accounting System (MMAS)	0.6%	3.3%
9	Engineering Drawings	0.6%	3.3%
10	Government Property Administration	0.5%	2.8%
	Total of Estimated 18 % Cost Premium	8.5%	47.2%

Nine out of these ten cost drivers still exist today. The exception is MIL-Q-9858A, which the International Standards Organization's (ISO) 9000 series and other commercially based quality standards replaced. However, the process to obtain ISO certification is expensive and firms that pursue certification transfer the cost to the consumer through the product price. Today's competitive marketplace compels these firms to adopt ISO 9000 quality standards. As a result, through the purchase of commercial items the Government is able to share the cost with the general population.

The determination of commerciality on a procurement item relieves both the Government and potential suppliers from costly administrative and regulatory requirements. Specifically it eliminates, either directly or indirectly, cost drivers 1, 2, 4, 7, 9, and most likely 10. This is a cost savings of 5.6 percent of the contract price. When talking about multi-million dollar contracts, 5.6 percent can add up very quickly.

⁸⁴ Created with data from: General Accounting Office, GAO/NSIAD-97-48, *Acquisition Reform: DoD Faces Challenges in Reducing Oversight Costs*, (Washington, D.C.: 1997), 20-21.

2. Advance Concept Technology Demonstration

An ACTD is designed to integrate technology into a prototype capability so the warfighter can evaluate the capability in an operational environment and determine the military utility of the technology and the capability it enables. One of the primary goals of the program is to “prepare to transition the capability into acquisition without loss of momentum...”⁸⁵. Based upon the preceding analysis of the performance level and Technology Readiness Level of the PVPC, we believe it can be integrated into a useful prototype technology demonstrator and provide the warfighter with a useful increment of military capability in renewable power for numerous battery applications.

⁸⁵ <<http://www.acq.osd.mil/actd/intro.htm#Introduction>>, [20 April 2005]

V. CONCLUSIONS AND RECOMMENDATIONS

A. INTRODUCTION

In this final Chapter of the report, we answer the primary and secondary research questions posed in Chapter I. We also make recommendations for further research.

B. CONCLUSIONS

1. Primary Research Questions:

- a. *Does the PVPC Allow a Solar Power System to Produce 25 Percent More Power Than an Identical System without the Technology Integrated?*

As computed from the information in Tables 22 and 23, testing has demonstrated that the PVPC, on average, with a statistically significant point-estimate of 39.49%, produced more power than did an identical system without this technology. In addition, we estimate, with 95% confidence, that the PVPC converts between 30.39% - 48.60% more power than the standard system.

As indicated in our analysis, certain tests were outliers and not included in the final summary analysis we conducted to reach the above general conclusion. Such a test was the LM-3 panel test conducted with the 0916 PVPC charging the 12V Ultra-Life battery. Aтира conducted this test, shown in Table 2, to demonstrate that with the technology, a 9V panel could charge a 12V battery. The fact that it converted previously unusable power into usable power is an infinite improvement. We could not devise a methodology to show quantitatively how much more usable power is being produced, only the difference between what is produced, whether usable or not. This is an important distinction, because devising a surrogate for an infinite improvement would likely increase the comparative advantage of the PVPC beyond the figures provided above. Obviously, enabling a system to produce usable power when it previously could not is a significant capability improvement. In summary, we believe the 39.49% point estimate is a conservative figure.

With this technology, the capability exists to charge various batteries with a single panel that formerly only serviced a single battery. It also provides the capability to generate more power during periods of low light than the standard solar power system,

b. What is the Current Technology Readiness Level of the PVPC, as Defined by DoD 5000.2-R Appendix 6?

The analysis in Chapter IV identifies and correlates the necessary supporting information to justify that the PVPC meets all of the criteria for Technology Readiness Level 5; however, it is very close to meeting the criteria for TRL 6. To explain further, the technology maturity of the PVPC exceeds level five, however, the formal documentation to justify an assessment at TRL 6 is not available. In addition, we also conclude that the PVPC's current level of technological maturity can increase to TRL 6, or higher, with the inclusion of three key improvements, all of which are currently being actively pursued. The first key improvement is miniaturizing the circuit board to the size of a standard computer microprocessor (about the size of a postage stamp). The second key improvement is to incorporate a microprocessor into the circuit that will allow the PVPC to perform optimally over a larger range of input power and output loads. This would eliminate the need to design specific PVPC circuits for each application. The third key improvement is to demonstrate the producibility of the improved circuit as described above

Although improvements could be made in its current configuration, and at a TRL 5, the PVPC could be horizontally inserted into an existing battery powered military product and would provide a usable increment of capability that significantly exceeds that of the current system.

2. Secondary Research Questions:

a. What is the Appropriate Insertion Method for the PVPC into the DoD Acquisition System?

Under the umbrella of commercial item acquisition, the PVPC can be inserted both as an HTI and as an ACTD. We formed our conclusion, and later, our recommendation for the PVPC, from three intermediate conclusions.

After analyzing the PVPC against the criteria in the FAR that defines a commercial item, our first conclusion is the PVPC meets the definition of a commercial

item. Commercial item classification eases many rules and regulations in the acquisition process. It also allows the Government to realize cost savings and benefits from a more fast-paced, market-driven series of technological updates in the areas of functional capabilities, reliability, availability, and maintainability. Secondly, we conclude that, based on the goals and objectives of the Advanced Technology Concept Demonstration Program and the current level of technological maturity of the PVPC, that it is an excellent candidate for the ACTD Program. Thirdly, we conclude that many military programs that deal with battery powered or charging applications could benefit greatly from a horizontal technology insertion of the PVPC. For these programs, an HTI of the PVPC would be the next evolutionary step in the incremental development of their capabilities.

b. What Organization Should Provide Management and Oversight of PVPC Development?

We conclude that it would be necessary for command and control, logistical, and configuration management purposes to designate a Joint Program Office or a DoD Program Office to manage this effort. Given the vast applications for this product, it is important that the PVPC be managed at the Joint level. This method is preferred to the Services independently procuring and inserting it into their programs. We conclude the DoD Project Manager for Mobile Electric Power (MEP) manage and oversee the PVPC development. This Project manager:

is responsible for research, development, acquisition, fielding, and logistics support of a modernized standard family of mobile electric power systems for all services throughout the Department of Defense which range from small, 0.5kW manportable systems to large 920kW prime power generating systems.⁸⁶

C. RECOMMENDATIONS

1. Overall Recommendations for the PVPC

We recommend a two-pronged approach to insert the PVPC into the DoD Acquisition Framework. The PVPC should be acquired as a commercial item and inserted into currently fielded or more mature acquisition programs (past Milestone B) as

⁸⁶ Project Manager Combat Systems Support (PM CSS) Homepage, <http://peocscss.tacom.army.mil/pmCSS.html>, May 2005.

a Horizontal Technology Insertion. Simultaneously, the PVPC should be approved for an ACTD to demonstrate its enhanced power production capabilities in less mature acquisition programs that could benefit from a renewable power source.

The first prong of this approach (HTI) utilizes the evolutionary acquisition approach that leverages this product's potential to add capability to the next envisioned "block" upgrade of any system that can take advantage of the increased power it produces. An example of the HTI approach would be to take the Army's current PP-8498/U Multi-Port Universal Battery Charger (NSN: 6130-01-495-2839) and introduce a solar powered variant with integrated PVPC technology or to add this capability to the current version via a modification or upgrade kit. The PP-8498/U, seen below in Figure 21, is the Army's newest smart charger for a plethora of batteries. Table 25 lists the batteries it can charge and examples of the end items they power.



Figure 21. PP-8498/U Multi-Port Universal Battery Charger⁸⁷

⁸⁷ From the Integrated Power Management Homepage, https://lrcteams.monmouth.army.mil/QuickPlace/ipm/PageLibrary85256A2B0062C0F7.nsf/h_Toc/F8DED136FF17831985256B3E006CF4E0/?OpenDocument, May 2005.

Table 25. PP-8498/U Compatible Rechargeable Batteries and End Items They Power (After Integrated Power Management Homepage, May 2005)

<u>Rechargeable Battery Nomenclature</u>	<u>Non Rechargeable Equivalent</u>	<u>End Item Example:</u>
BB-2590/U Li-Ion	BA-5590 and BB390A/B	Most SINGARS, M22 & AN/PSC-5
BB-390B/U. Replacement for the BB-390A/U	BA-5590	Above applications plus JAVELIN
BB-388A/U	BA-5588	AN/PRC-126
BB-516A/U	NONE	AN/PVS-6 (MELIOS)
BB-503A/U	NONE	Dragon Night sight (JAVELIN) is replacing)
BB-2847A/U	BA-5347	Thermal Weapon Sight (TWS): AN/PAS-13
BB-2800/U	BA-5800	AN/PSN-11 (PLGR-GPS) CAM /JCAM
BB-2600A/U	BA-5600	HTU and AN/PSC-2,
BB-557/U	BA-5557	REMBASS (AN/GSQ-187)

The second prong of the approach is to use an ACTD to integrate the technology into an evolving capability to determine the military utility of combining the technology and the capability. The Future Combat System (FCS) offers such an opportunity. FCS may benefit greatly by integrating the PVPC into many of its emerging technologies including its Unattended Munitions family of systems. We believe all three systems in this family are excellent ACTD candidates. The Non-Line-of-Sight Launch System (NLOS-LS), the Intelligent Munitions Systems (IMS), and the Unattended Ground Sensors (UGS), will all likely require extended operations battery technology to meet the “unattended” period specified in the FCS Operational Requirements Document. Alternatively, the adoption of a renewable power supply may satisfy the requirement.

This family of systems is intended to operate in austere environments and transmit their data to remotely located operators and decision makers. Figure 22 below depicts current concept computer renderings of these systems.

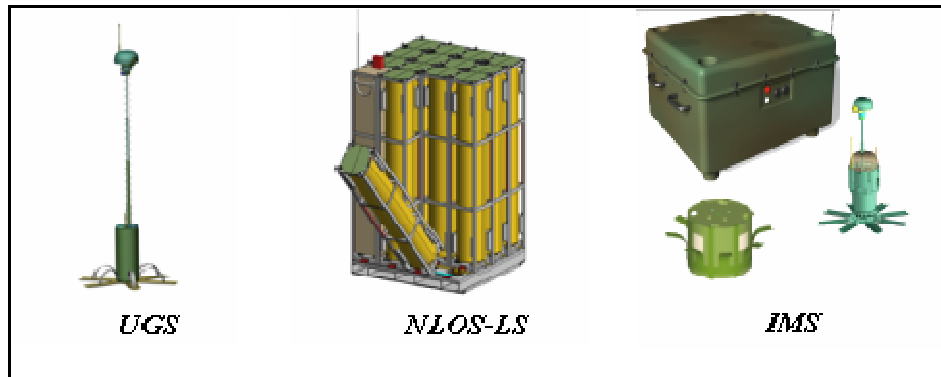

Figure 22. Unattended Munitions Family of Systems (After: Program Manager Unit of Action, White Paper)⁸⁸

By having an efficient solar power generation and battery charging capability incorporated, these systems could sustain themselves for a significantly longer, if not indefinite period, as compared to battery power alone. This is the same concept as fitting NASA spacecraft with solar panels so they can continue to transmit their data for decades in the austere environment of space.

2. Recommendations for Future Research

- Student team conduct an Analysis of Alternatives to determine which program would be the most beneficial to use as an ACTD
- Student team prepare the recommendation packet for acceptance into the ACTD program
- NPS and Atira, under the provisions of the CRADA, modify a PP-8498/U Multi-Port Universal Battery Charge to determine the usefulness of a solar charging variant

⁸⁸ Future Combat Systems, *18 + 1 + 1 Overview*, Whitepaper, (Program Manager Unit of Action, 2005), 8-9.

- Since the PVPC is not restricted to solar energy, future studies could examine other applications for it, such as hydro-electric conversion, geothermal-electric conversion, or the conversion of wind into electricity. All these sources have points at which the “wheel” is turning and producing power, but that power does not meet the threshold requirements of the system. Using the PVPC to make a low flow water or wind source produce usable power could open up a whole new area of power production in these industries.

THIS PAGE INTENTIONALLY LEFT BLANK

APPENDICES

APPENDIX A – PVPC TEST PLAN

TEST PLAN Photovoltaic Power Converter (PVPC)

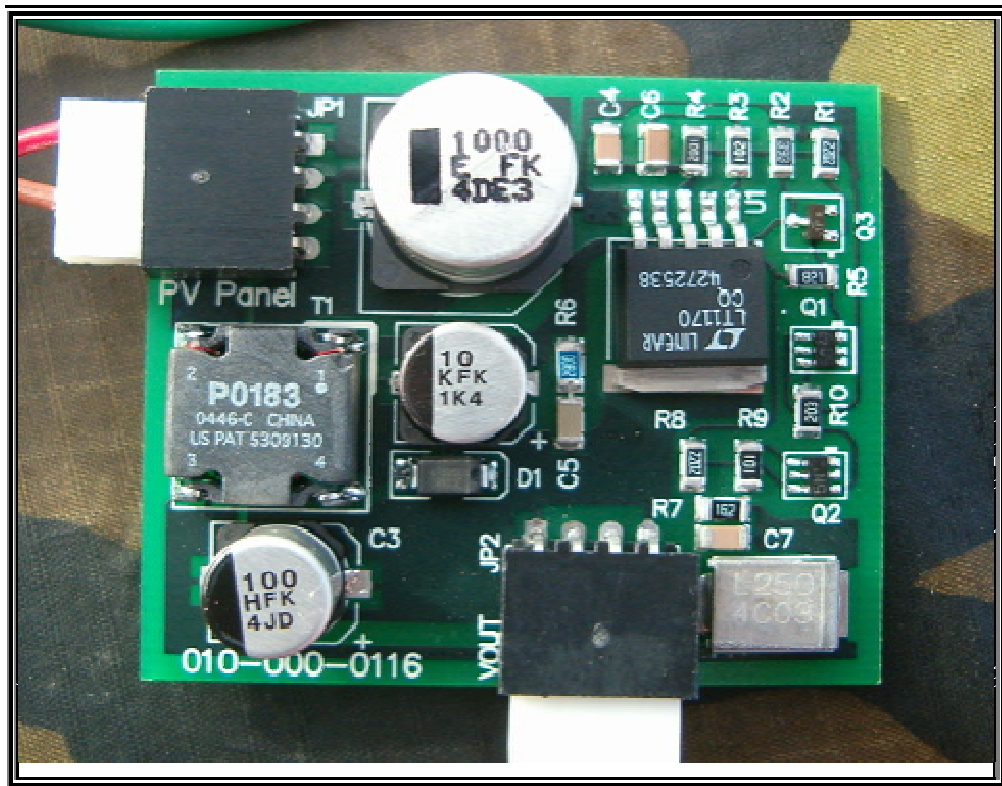

April 10, 2005

APPENDIX A – TEST PLAN
TABLE OF CONTENTS

1.0 OBJECTIVE3

2.0 TEST APPROACH.....3

3.0 EQUIPMENT LIST4

3.1 GLASS PANEL-7.4V BATTERY FIELD PERFORMANCE TEST.4

3.2 GLASS PANEL –3.7V BATTERY FIELD PERFORMANCE TEST.....4

3.3 FLEXIBLE PANEL-7.4V BATTERY FIELD PERFORMANCE TEST4

3.4 FLEXIBLE PANEL-3.7V BATTERY FIELD PERFORMANCE TEST4

4.0 PERSONNEL REQUIREMENTS5

5.0 TEST DURATION.....6

5.1 GLASS PANEL-7.4V BATTERY FIELD PERFORMANCE TEST6

5.2 GLASS PANEL –3.7V BATTERY FIELD PERFORMANCE TEST.....6

5.3 FLEXIBLE PANEL-7.4V BATTERY FIELD PERFORMANCE TEST6

5.4 FLEXIBLE PANEL-3.7V BATTERY FIELD PERFORMANCE TEST6

6.0 TEST LOCATIONS6

7.0 TEST SETUP7

8.0 TEST PROCEDURES.....8

9.0 TEST DATA9

9.1 GLASS PANEL-7.4V BATTERY FIELD PERFORMANCE TEST9

9.2 GLASS PANEL –3.7V BATTERY FIELD PERFORMANCE TEST.....15

9.3 FLEXIBLE PANEL-7.4V BATTERY FIELD PERFORMANCE TEST:.....17

9.4 FLEXIBLE PANEL-3.7V BATTERY FIELD PERFORMANCE TEST17

1.0 OBJECTIVE

To independently verify that a solar power system integrated with a PVPC, developed by Atira Technologies will produce more power than an identical system without the PVPC.

Atira technologies presented data from previous tests the company has conducted; however, to date, independent tests have not been conducted to validate Atira's test results. The tests within this test plan will support or refute Atira's previous test results that suggest the PVPC allows more potential power to be converted into usable power.

2.0 TEST APPROACH

The approach of this test plan is to establish field-test procedures for the PVPC that will measure the PVPC's performance levels in a relevant environment. All tests conducted will be side-by-side comparisons of identical solar power systems, under the same conditions, except that one system has the PVPC integrated.

Field-testing of the PVPC will consist of testing the PVPC's performance in at least four differently configured solar power systems. These tests will be conducted in the uncontrolled, natural environment that exists on the scheduled test days. The intent of the field tests is to capture performance data relevant to a typical temperate climate. All field tests will be conducted on the rooftop of Ingersoll Hall on the campus of the Naval Postgraduate School (NPS), in Monterey California.

3.0 EQUIPMENT LIST

3.1 Glass Panel-7.4V Battery Field Performance Test.

- (1) Solengy, ASI-F 5/12 framed solar module, quantity (2).
- (2) UBC36106102/PCM Ultralife Polymer 3.7V Rechargeable Battery, quantity (8)
- (3) Atira Technologies 1216 Photovoltaic Power Controller, quantity (1)
- (4) Digital Multi-meter such as a Fluke 87, quantity (4)
- (5) Digital Light Meter, Reed ST-1300 (1)
- (6) Digital Infrared Mini Thermometer (1)
- (7) Digital Camera, quantity (1)
- (8) Laptop computer, quantity (1)

3.2 Glass Panel –3.7V Battery Field Performance Test.

- (1) Solengy, ASI-F 5/12 framed solar module, quantity (2).
- (2) UBC36106102/PCM Ultralife Polymer 3.7V Rechargeable Battery, quantity (8)
- (3) Atira Technologies 1216 Photovoltaic Power Controller, quantity (1)
- (4) Digital Multi-meter such as a Fluke 87, quantity (4)
- (5) Digital Light Meter, Reed ST-1300 (1)
- (6) Digital Infrared Mini Thermometer (1)
- (7) Digital Camera, quantity (1)
- (8) Laptop computer, quantity (1)

3.3 Flexible Panel-7.4V Battery Field Performance Test

- (1) Uni-Solar LM-3 solar module, quantity (4).
- (2) UBC36106102/PCM Ultralife Polymer 3.7V Rechargeable Battery, quantity (8)
- (3) Atira Technologies 0916 Photovoltaic Power Controller, quantity (1)
- (4) Digital Multi-meter such as a Fluke 87, quantity (4)
- (5) Digital Light Meter, Reed ST-1300 (1)
- (6) Digital Infrared Mini Thermometer (1)
- (7) Digital Camera, quantity (1)
- (8) Laptop computer, quantity (1)

3.4 Flexible Panel-3.7V Battery Field Performance Test

- (1) Uni-Solar LM-3 solar module, quantity (4).
- (2) UBC36106102/PCM Ultralife Polymer 3.7V Rechargeable Battery, quantity (8)
- (3) Atira Technologies 0916 Photovoltaic Power Controller, quantity (1)
- (4) Digital Multi-meter such as a Fluke 87, quantity (4)
- (5) Digital Light Meter, Reed ST-1300 (1)
- (6) Digital Infrared Mini Thermometer (1)
- (7) Digital Camera, quantity (1)
- (8) Laptop computer, quantity (1)

4.0 PERSONNEL REQUIREMENTS

- (1) Test Officer: MAJ Steven Ansley, MBA candidate at NPS, Graduate School of Business and Public Policy (GSBPP)
- (2) Test Officer: MAJ Lewis Phillips, MBA candidate at NPS, GSBPP
- (3) System Engineer: Stefan Matan, PVPC Inventor, Atira Technologies
- (4) System Engineer: Dave Besser, Atira Technologies

5.0 TEST DURATION

5.1 Glass Panel-7.4V Battery Field Performance Test

Setup requires approximately 30 Minutes. Testing takes an estimated 4-7 hours (Duration is dependent on weather conditions and time of year). Take down requires approximately 30 minutes.

5.2 Glass Panel-3.7V Battery Field Performance Test

Setup requires approximately 30 Minutes. Testing takes an estimated 6-9 hours (Duration is dependent on weather conditions and time of year). Take down requires approximately 30 minutes.

5.3 Flexible Panel-7.4V Battery Field Performance Test

Setup requires approximately 30 Minutes. Testing takes an estimated 4-7 hours (Duration is dependent on weather conditions and time of year). Take down requires approximately 30 minutes.

5.4 Flexible Panel-3.7V Battery Field Performance Test

Setup requires approximately 30 Minutes. Testing takes an estimated 6-9 hours (Duration is dependent on weather conditions and time of year). Take down requires approximately 30 minutes.

6.0 TEST LOCATIONS

Field Tests were conducted on the rooftop of Ingersoll Hall. Ingersoll Hall is located on the campus of the Naval Post Graduate School in Monterey, CA.

7.0 TEST SETUP

All field tests were set-up in the same manner to measure the performance levels of the solar power systems with and without the integrated PVPC. Set-up checks are presented below:

- (1) Inventory test equipment.
- (2) Prepare Excel spreadsheet to record test results as illustrated in the figure below.

Glass Test 3 (7 April 05)									
	Class A					Class B With PVPC			
Time	Light Reading (Lux)	Array Temp	Battery Current (mA)	Battery Voltage	Watts (mW)	Array Temp	Battery Current (mA)	Battery Voltage	Watts (mW)
7:00 AM									

- (3) Verify batteries are appropriately discharged.
- (4) Verify battery indicators on Multi-meters, Light Meter, and Thermometer show sufficient charge for duration of test – have spare batteries on hand.
- (5) Label and arrange test equipment. Label the system without the PVPC as Flex A or Glass A as appropriate. Label the system with the PVPC as Flex B or Glass B as appropriate.
- (6) Connect all meters to the systems according to wiring diagram illustrated below.

CIRCUIT DIAGRAM WITHOUT PVPC CIRCUIT DIAGRAM WITH PVPC

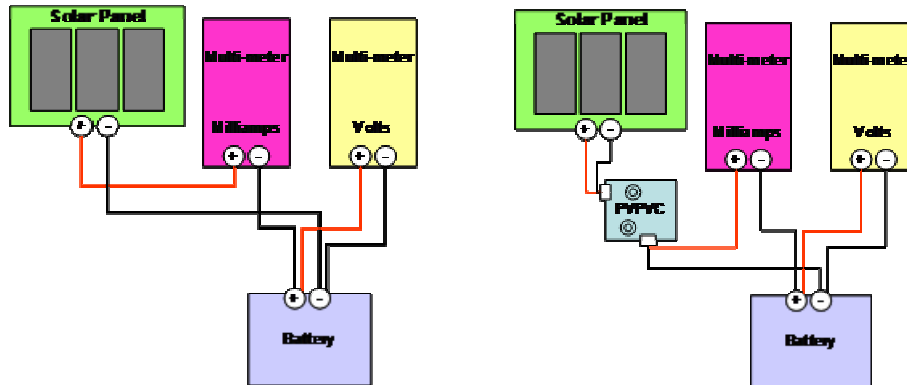

- (7) Turn on all meters and equipment and test circuitry.

8.0 TEST PROCEDURES

- (1) Turn on all test equipment
- (2) Take a digital picture of all meter readings to establish beginning time and data. Ensure all meters for the test are visible and readable in the picture.
- (3) Determine the beginning surface temperature of the center solar panel for each system A and system B using the IR thermometer. Aim the thermometer at approximate center point of the appropriate panel by using the thermometer's integrated laser pointer. Record temperature reading
- (4) Record the beginning data readings from the digital picture and thermometer into the excel spreadsheet.
- (5) Repeat steps (2) and (3) at the next quarter hour increment and every quarter hour increment until the test is terminated.
- (6) Terminate the test when the battery voltage reading for either systems exceeds 8.1V when using the UBC36106102/PCM Ultralife Polymer battery or appropriate maximum charge for whatever battery is being used.

9.0 TEST DATA

The key data elements of our tests are the performance results of the solar power systems in the field tests. Performance of the systems, in all tests, is measured in Volts direct current (Volts, V, or VDC) and milliamperes (milliamps or mA). Data was recorded photographically, to capture the exact readings of all meters at the same point in time. The photographic data elements of Volts and mA were then transferred to an MS Excel spreadsheet for presentation and analysis, in which Watts were calculated. Surface temperature readings were taken sequentially with no more than a five second time interval between the system A panel and the system B panel. Temperatures were recorded manually in degrees Fahrenheit and then transferred to the MS Excel spreadsheet for presentation and analysis.

9.1 Glass Panel-7.4V Battery Field Performance Test

- (1) The data for Glass Test 1 is presented below. The first table depicts the recorded test data while the second table presents the hourly weather conditions recorded for the local area (Weather conditions were recorded from www.weatherchannel.com for Monterey CA.)





Glass Test 1 With 7.4V Battery (6 April 05)									
Time	Light Reading (Lux)	Glass A				Glass B With PVPC			
		Array Temp	Battery Current (mA)	Battery Voltage	Watts (mW)	Array Temp	Battery Current (mA)	Battery Voltage	Watts (mW)
8:00 AM	25800	63	100	7.76	776.0	61	135	7.71	1040.85
8:15 AM	34400	71	125	7.78	972.5	67	160	7.74	1238.4
8:30 AM	18400	62	52	7.75	403.0	58	98	7.71	755.58
8:45 AM	21100	61	70	7.76	543.2	58	100	7.73	773
9:00 AM	24000	61	81	7.77	629.4	58	125	7.75	968.75
9:15 AM	28200	64	100	7.78	778.0	63	150	7.75	1162.5
9:30 AM	72000	99	250	7.83	1957.5	97	380	7.85	2983
9:45 AM	70600	101	270	7.84	2116.8	99	400	7.87	3148
10:00 AM	64200	92	225	7.84	1764.0	89	360	7.87	2833.2
10:15 AM	66900	96	250	7.87	1967.5	95	375	7.9	2962.5
10:30 AM	82400	105	300	7.9	2370.0	102	425	7.93	3370.25
10:45 AM	60900	96	220	7.92	1742.4	92	330	7.94	2620.2
11:00 AM	71600	86	235	7.94	1865.9	83	370	7.96	2945.2
11:15 AM	64400	88	245	7.96	1950.2	81	350	7.99	2796.5
11:30 AM	60600	92	220	7.98	1755.6	86	320	8.02	2566.4
11:45 AM	96800	92	325	8.03	2609.8	85	460	8.08	3716.8

April 6, 2005 Hourly Conditions as reported at

Monterey

April 6

[Back to previous page](#)







Time	Condition	Felt like	Dew Point	Humid.	Visibility	Press.	Wind
Sunrise at 6:46 AM							
7:54 AM	 Fair 48°F	45°F	42°F	80%	10.0 miles	30.03 ↓	From SE 6mph
8:54 AM	 Fair 55°F	55°F	44°F	67%	10.0 miles	30.03 →	calm
9:54 AM	 Fair 62°F	62°F	45°F	53%	10.0 miles	30.03 →	Variable 3mph
10:54 AM	 Fair 64°F	64°F	45°F	50%	10.0 miles	30.05 ↑	From W 9mph
11:54 AM	 Fair 61°F	61°F	49°F	64%	10.0 miles	30.06 ↑	From W 9mph

- (2) The data for Glass Test 2 is presented below. The first table depicts the recorded test data while the second table presents the hourly weather conditions recorded for the local area (Weather conditions were recorded from www.weatherchannel.com for Monterey CA.

Glass Test 2 With 7.4V Battery (6 April 05)									
Time	Light Reading (Lux)	Glass A				Glass B With PVPC			
		Array Temp	Battery Current (mA)	Battery Voltage	Watts (mW)	Array Temp	Battery Current (mA)	Battery Voltage	Watts (mW)
12:15 PM	72600	105	308	7.23	2226.8	99	452	7.26	3281.5
12:30 PM	102200	110	409	7.41	3030.7	105	535	7.53	4028.6
12:45 PM	70900	104	257	7.46	1917.2	96	401	7.59	3043.6
1:00 PM	99100	110	390	7.56	2948.4	105	502	7.69	3860.4
1:15 PM	98500	117	376	7.57	2846.3	109	494	7.72	3813.7
1:30 PM	99100	115	377	7.58	2857.7	108	476	7.75	3689.0
1:45 PM	98900	113	369	7.61	2808.1	108	473	7.79	3684.7
2:00 PM	97800	112	359	7.63	2739.2	107	456	7.82	3565.9
2:15 PM	97000	109	347	7.65	2654.6	103	450	7.85	3532.5
2:30 PM	95400	110	336	7.67	2577.1	105	430	7.87	3384.1
2:45 PM	93300	107	318	7.69	2445.4	101	412	7.89	3250.7
3:00 PM	91300	107	305	7.7	2348.5	101	398	7.91	3148.2
3:15 PM	88900	99	287	7.72	2215.6	94	380	7.93	3013.4
3:30 PM	85700	96	270	7.73	2087.1	91	358	7.95	2846.1
3:45 PM	83200	92	253	7.75	1960.8	91	341	7.98	2721.2
4:00 PM	78300	86	230	7.75	1782.5	83	314	8	2512.0
4:15 PM	75600	85	211	7.76	1637.4	82	288	8.01	2306.9
4:30 PM	71700	77	192	7.77	1491.8	76	264	8.04	2122.6
4:45 PM	55900	69	118	7.76	915.7	66	166	8.03	1333.0
5:00 PM	33000	64	73	7.76	566.5	62	110	8.03	883.3
5:15 PM	47200	64	110	7.77	854.7	64	155	8.05	1247.8
5:30 PM	28600	73	78	7.77	606.1	69	120	8.06	967.2

April 6, 2005 Hourly Conditions as reported at

Monterey

Time	Condition	Felt like	Dew Point	Humid.	Visibility	Press.	Wind
Sunrise at 6:46 AM							
11:54 AM	 Fair 61°F	61°F	49°F	64%	10.0 miles	30.06 ↑	From W 9mph
12:54 PM	 Fair 62°F	62°F	45°F	53%	10.0 miles	30.04 ↓	From W 12mph
1:54 PM	 Fair 63°F	63°F	47°F	56%	10.0 miles	30.03 ↓	From WSW 9mph
2:54 PM	 Fair 63°F	63°F	47°F	56%	10.0 miles	30.01 ↓	From W 10mph
3:54 PM	 Fair 61°F	61°F	49°F	64%	10.0 miles	30.00 ↓	From W 15mph
4:54 PM	 Partly Cloudy 60°F	60°F	49°F	67%	10.0 miles	30.00 →	From W 14mph
5:54 PM	 Partly Cloudy 57°F	57°F	46°F	67%	10.0 miles	29.98 ↓	From W 9mph

- (3) The data for Glass Test 3 is presented below. The first table depicts the recorded test data while the second table presents the hourly weather conditions recorded for the local area (Weather conditions were recorded from www.weatherchannel.com for Monterey CA.

Glass Test 3 With 7.4V Battery (7 April 05)									
Time	Light Reading (Lux)	Glass A				Glass B With PVPC			
		Array Temp	Battery Current (mA)	Battery Voltage	Watts (mW)	Array Temp	Battery Current (mA)	Battery Voltage	Watts (mW)
7:15 AM	500	50	2	7.5	15	50	0	7.41	0
7:30 AM	1400	51	5	7.5	37.5	51	0	7.41	0
7:45 AM	1800	51	7	7.51	52.57	51	0	7.41	0
8:00 AM	3600	52	14	7.52	105.28	52	3	7.42	22.26
8:15 AM	7100	47	24	7.53	180.7	48	22	7.43	163.46
8:30 AM	9700	49	33	7.54	248.8	49	39	7.46	290.94
8:45 AM	13900	50	46	7.55	347.3	50	63	7.49	471.87
9:00 AM	8100	57	26	7.54	196.0	55	26	7.48	194.48
9:15 AM	900	54	32	7.55	241.6	52	37	7.49	277.13
9:30 AM	11700	54	37	7.55	279.4	53	48	7.51	360.48
9:45 AM	25700	59	101	7.6	767.6	57	159	7.58	1205.22
10:00 AM	33700	62	121	7.61	920.8	59	187	7.6	1421.2
10:15 AM	24000	63	87	7.6	661.2	60	147	7.59	1115.73
10:30 AM	42100	63	125	7.63	953.8	61	188	7.61	1430.68
10:45 AM	data was not collected for this period								
11:00 AM	39500	62	104	7.63	793.5	60	163	7.64	1245.32
11:15 AM	40600	62	106	7.64	809.8	59	159	7.65	1216.35
11:30 AM	52500	65	134	7.64	1023.8	62	208	7.68	1597.44
11:45 AM	68100	76	183	7.65	1400.0	69	275	7.71	2120.25

April 7, 2005 Hourly Conditions as reported at

Monterey

Yesterday

[Back to previous page](#)

Time	Condition	Felt like	Dew Point	Hum id.	Visib.	Press.	Wind
Sunrise at 6:44 AM							
6:54 AM	 Cloudy 52°F	52°F	49°F	89%	10.0 miles	30.01 ↑	From SW 6mph
7:54 AM	 Cloudy 52°F	52°F	49°F	89%	10.0 miles	30.03 ↑	From SW 5mph
8:54 AM	 Partly Cloudy 54°F	54°F	50°F	86%	10.0 miles	30.04 ↑	From SW 3mph
9:17 AM	 Heavy Rain 54°F	54°F	50°F	88%	1.8 miles	30.05 ↑	From W 7mph
9:27 AM	 Light Rain 52°F	52°F	46°F	82%	2.0 miles	30.06 ↑	From W 6mph
9:35 AM	 Cloudy 54°F	54°F	48°F	82%	10.0 miles	30.06 →	From WNW 7mph
9:54 AM	 Cloudy 53°F	53°F	49°F	86%	10.0 miles	30.07 ↑	From NW 9mph
10:54 AM	 Cloudy 55°F	55°F	47°F	74%	10.0 miles	30.09 ↑	From W 12mph
11:54 AM	 Partly Cloudy 57°F	57°F	49°F	74%	10.0 miles	30.10 ↑	From WNW 12mph

9.2 Glass Panel –3.7V Battery Field Performance Test

A single iteration of this test was conducted. The data for this test is presented below. The first table depicts the recorded test data while the second table presents the hourly weather conditions recorded for the local area (Weather conditions were recorded from www.weatherchannel.com for Monterey CA.

Class Test 4 With 3.7V Battery (10 April 05)									
Time	Light Reading (Lux)	Class A				Class B With PVPC			
		Array Temp	Battery Current (mA)	Battery Voltage	Watts (mW)	Array Temp	Battery Current (mA)	Battery Voltage	Watts (mW)
6:30 AM	75	42	0	3.75	0.00	42	0	3.74	0.00
Sunrise 6:40	499	42	1	3.75	3.75	42	0	3.75	0.00
6:45 AM	989	43	3	3.76	11.28	43	0	3.74	0.00
7:00 AM	3020	40	9	3.76	33.84	40	0	3.75	0.00
7:15 AM	6400	47	21	3.77	79.17	46	20	3.75	75.04
7:30 AM	11000	52	35	3.77	131.95	51	49	3.76	184.34
7:45 AM	10000	44	33	3.77	124.41	44	48	3.76	180.62
8:00 AM	29300	52	55	3.78	207.90	52	91	3.77	343.43
8:15 AM	17100	57	55	3.78	207.90	57	94	3.78	354.85
8:30 AM	31700	59	100	3.79	379.00	60	173	3.79	655.67
8:45 AM	44700	66	138	3.80	524.40	66	235	3.80	893.00
9:00 AM	51500	75	163	3.80	619.40	78	272	3.80	1034.69
9:15 AM	57700	82	186	3.80	706.80	83	302	3.81	1150.02
9:30 AM	63400	86	208	3.81	792.48	91	336	3.82	1281.84
9:45 AM	70200	73	231	3.81	880.11	77	369	3.83	1412.53
10:00 AM	75000	82	250	3.82	955.00	85	392	3.84	1504.10
10:15 AM	80800	56	269	3.83	1030.27	65	418	3.85	1607.21
10:30 AM	84500	82	286	3.83	1095.38	83	437	3.85	1682.45
10:45 AM	88800	89	299	3.84	1148.16	93	446	3.86	1719.33
11:00 AM	92800	88	315	3.84	1209.60	93	464	3.86	1789.65
11:15 AM	97800	90	326	3.85	1255.10	94	483	3.86	1865.35
11:30 AM	99800	77	334	3.86	1289.24	82	491	3.87	1898.70
11:45 AM	101800	85	345	3.87	1335.15	92	500	3.87	1935.50
12:00 PM	104800	88	353	3.87	1366.11	94	507	3.88	1964.63
12:15 PM	107300	90	360	3.88	1396.80	95	516	3.88	2002.08
12:30 PM	108000	82	365	3.88	1416.20	88	518	3.88	2009.84
12:45 PM	109200	84	368	3.88	1427.84	90	522	3.89	2027.97
1:00 PM	109800	77	368	3.88	1427.84	82	521	3.89	2027.21
1:15 PM	108800	83	365	3.89	1419.85	90	520	3.90	2026.44
1:30 PM	107200	83	365	3.89	1419.85	91	520	3.90	2030.08

1.1 11 April 2005, Hourly Conditions as reported at

Monterey

Yesterday		Back to previous page						
Time	Condition	Felt like	Dew Point	Humid.	Visibility	Press.	Wind	
6:13 AM	 Partly Cloudy 48°F	46°F	46°F	93%	6.0 miles	30.13 →	From ESE 5mph	
Sunrise at 6:40 AM								
6:54 AM	 Fair 48°F	48°F	43°F	83%	8.0 miles	30.13 →	Variable 3mph	
7:42 AM	 Partly Cloudy 48°F	46°F	45°F	87%	6.0 miles	30.16 ↑	From E 6mph	
7:54 AM	 Partly Cloudy 48°F	45°F	45°F	89%	7.0 miles	30.16 →	From ESE 6mph	
8:01 AM	 Mostly Cloudy 48°F	45°F	45°F	87%	7.0 miles	30.16 →	From ESE 7mph	
8:54 AM	 Haze 52°F	52°F	47°F	83%	5.0 miles	30.17 ↑	calm	
9:01 AM	 Haze 54°F	54°F	48°F	82%	6.0 miles	30.17 →	calm	
9:54 AM	 Fair 57°F	57°F	47°F	69%	7.0 miles	30.17 →	From WNW 5mph	
10:54 AM	 Fair 57°F	57°F	49°F	74%	7.0 miles	30.19 ↑	From NNW 8mph	
11:54 AM	 Haze 57°F	57°F	50°F	77%	5.0 miles	30.18 ↓	From NNW 7mph	

9.3 Flexible Panel-7.4V Battery Field Performance Test:

A single iteration of this test was conducted. The data for this test is presented below. The first table depicts the recorded test data while the second table presents the hourly weather conditions recorded for the local area (Weather conditions were recorded from www.weatherchannel.com for Monterey CA.

Flex Test 2 With 7.4V Battery (10 April 05)									
Time	Light Reading (Lux)	Flex A				Flex B With PVPC			
		Array Temp	Battery Current (mA)	Battery Voltage	Watts (mW)	Array Temp	Battery Current (mA)	Battery Voltage	Watts (mW)
10:30 AM	84500	96	739	7.77	5742.03	92	604	7.57	4572.28
10:45 AM	88800	107	738	7.85	5793.3	106	613	7.71	4726.23
11:00 AM	92800	105	787	7.95	6256.65	105	622	7.76	4826.72
11:15 AM	97800	101	820	8.03	6584.6	102	643	7.82	5028.26
11:30 AM	99800	93	825	8.09	6674.25	89	653	7.87	5139.11
11:45 AM	101800	90	823	8.14	6699.22	97	654	7.92	5179.68
12:00 PM	104800	102	810	8.18	6625.8	100	646	7.95	5135.7
12:15 PM	107300	104	813	8.23	6690.99	103	659	7.99	5265.41

1.1 11 April 2005, Hourly Conditions as reported at Monterey

Yesterday Back to previous page

Time	Condition	Felt like	Dew Point	Hum id.	Visibility	Press.	Wind
9:54 AM	Fair 57°F	57°F	47°F	69%	7.0 miles	30.17 →	From NNW 5mph
10:54 AM	Fair 57°F	57°F	49°F	74%	7.0 miles	30.19 ↑	From NNW 8mph
11:54 AM	Haze 57°F	57°F	50°F	77%	5.0 miles	30.18 ↓	From NNW 7mph
12:54 PM	Haze 59°F	59°F	49°F	69%	6.0 miles	30.16 ↓	From NNW 6mph

9.4 Flexible Panel -3.7V Battery Field Performance Test

A single iteration of this test was conducted. The data for this test is presented below. The first table depicts the recorded test data while the second table presents the hourly weather conditions recorded for the local area (Weather conditions were recorded from www.weatherchannel.com for Monterey CA.

Flex Test 1 With 3.7V Battery (10 April 05)									
Time	Light Reading (Lux)	Flex A				Flex B With PVPC			
		Array Temp	Battery Current (mA)	Battery Voltage	Watts (mW)	Array Temp	Battery Current (mA)	Battery Voltage	Watts (mW)
6:30 AM	75	45	0	3.8	0	45	0	3.7	0
Sunrise 6:40	499	45	5	3.8	19	45	0	3.7	0
6:45 AM	989	44	9	3.8	34.2	45	0	3.71	0
7:00 AM	3020	42	28	3.81	106.68	42	16	3.71	59.36
7:15 AM	6400	51	65	3.83	248.95	49	88	3.75	330
7:30 AM	11000	55	109	3.84	418.56	55	168	3.79	636.72
7:45 AM	10000	47	98	3.84	376.32	47	142	3.79	538.18
8:00 AM	29300	56	159	3.86	613.74	54	250	3.83	957.5
8:15 AM	17100	60	167	3.86	644.62	60	254	3.83	972.82
8:30 AM	31700	66	297	3.92	1164.24	66	447	3.87	1729.89
8:45 AM	44700	79	421	3.96	1667.16	76	562	3.89	2186.18
9:00 AM	51500	84	488	3.99	1947.12	83	657	3.91	2568.87
9:15 AM	57700	94	552	4.00	2208	91	711	3.93	2794.23
9:30 AM	63400	102	614	4.03	2474.42	98	762	3.97	3025.14
9:45 AM	70200	91	674	4.07	2743.18	87	824	3.99	3287.76
10:00 AM	75000	102	725	4.1	2972.5	97	855	4.01	3428.55

1.1 11 April 2005, Hourly Conditions as reported at

Monterey

Yesterday Back to previous page							
Time	Condition	Felt like	Dew Point	Hum id.	Visibility	Press.	Wind
6:13 AM	 Partly Cloudy 48°F	46°F	46°F	93%	6.0 miles	30.13 →	From ESE 5mph
Sunrise at 6:40 AM							
6:54 AM	 Fair 48°F	48°F	43°F	83%	8.0 miles	30.13 →	Variable 3mph
7:42 AM	 Partly Cloudy 48°F	46°F	45°F	87%	6.0 miles	30.16 ↑	From E 6mph
7:54 AM	 Partly Cloudy 48°F	45°F	45°F	89%	7.0 miles	30.16 →	From ESE 6mph
8:01 AM	 Mostly Cloudy 48°F	45°F	45°F	87%	7.0 miles	30.16 →	From ESE 7mph
8:54 AM	 Haze 52°F	52°F	47°F	83%	5.0 miles	30.17 ↑	cal m
9:01 AM	 Haze 54°F	54°F	48°F	82%	6.0 miles	30.17 →	cal m
9:54 AM	 Fair 57°F	57°F	47°F	69%	7.0 miles	30.17 →	From WNW 5mph

THIS PAGE INTENTIONALLY LEFT BLANK

APPENDIX B - SAMPLE COMMERCIAL ITEM CHECKLIST⁸⁹

Commercial Item Checklist (Part 1: Items)

Item: PVPC

Part 1: Acquisition of Items

Can the Government's requirements (which should be performance based) be satisfied by—

1. An item that is *of a type* customarily used by the general public or by nongovernmental entities for purposes other than government purposes and that has been sold, leased, or licensed to the general public or that has been offered for sale, lease, or license to the general public?

A. If Yes, designate the item as commercial and annotate evidence of actual sale, lease, or license to the general public (or offer for the same), as appropriate:

As noted in Chapter III and discussed in Chapter IV.

B. If No, proceed.

2. An item that has evolved from an item described in 1 above through advances in technology or performance and that is not yet available in the commercial marketplace but will be available in time to satisfy the Government's delivery requirements?

A. If Yes, designate the item as commercial and annotate evidence that the item will be available in time to satisfy the Government's requirements.

B. If No, proceed.

3. An item that would meet 1 or 2 above but requires modifications of a type customarily available in the commercial marketplace or minor modifications of a type not customarily available in the commercial marketplace, made to meet Federal Government requirements?

⁸⁹ *Commercial Item Handbook*, Office of the Secretary of Defense, Acquisition, Technology and Logistics, November 2001, Appendix D.

A. If Yes, designate the item as commercial and annotate either evidence of the customary availability of modification in the commercial marketplace or the technical relationship between the modified item and the item that meets 1 or 2. (For the latter, attach drawings or comparison of the characteristics of the commercial item and the modified item, as appropriate).

B. If No, proceed.

4. Any combination of items meeting 1, 2, or 3 above that are of a type customarily combined and sold in combination to the general public?

A. If Yes, designate the combination as commercial and annotate evidence of the customary combination being sold to the general public.

B. If No, proceed.

5. Any item or combination of items that would meet 1, 2, 3, or 4 above but for being transferred between or among separate divisions, subsidiaries, or affiliates of a contractor?

A. If Yes, designate the item as commercial and annotate how the item would meet 1, 2, 3, or 4. _____

B. If No, proceed.

6. A nondevelopmental item that the procuring agency determines was developed exclusively at private expense and sold in substantial quantities, on a competitive basis, to multiple state and local governments?

A. If Yes, designate the nondevelopmental item as commercial and annotate evidence that it was 1) developed exclusively at private expense, and 2) sold competitively in substantial quantities to multiple state and local governments.

B. If No, recommend that the agency's requirements be revised to permit commercial solutions. If they cannot, recommend that noncommercial acquisition be considered (include Numbered Note 26 in the synopsis).

APPENDIX C – ACRONYMS AND ABBREVIATIONS

ACAT	Acquisition Category
AIS	Automated Information System
AO	Action Officer
AoA	Analysis of Alternatives
APB	Acquisition Program Baseline
ASD(C3I)	Assistant Secretary of Defense for Command, Control,
ASD(NII)	Assistant Secretary of Defense for Networks and Information
CAE	Component Acquisition Executive
CDD	Capability Development Document
CJCS	Chairman of the Joint Chiefs of Staff
CJCSM	Chairman of the Joint Chiefs of Staff Manual
CPD	Capability Production Document
DAB	Defense Acquisition Board
DAS	Defense Acquisition System
DLA	Defense Logistics Agency
DoD	Department of Defense
DoDD	Department of Defense Directive
DoDI	Department of Defense Instruction
DRR	Design Readiness Review
DUSD(S&T)	Deputy Under Secretary of Defense for Science and Technology
FRP	full-rate production
GAO	Government Accounting Office
GSBPP	Graduate School of Business and Public Policy
ICD	Initial Capabilities Document
IOC	initial operational capability
IOT&E	Initial Operational Test and Evaluation
IT OIPT	Information Technology Overarching Integrated Product Team
ITAB	Information Technology Acquisition Board
JROC	Joint Requirements Oversight Council
KPP	key performance parameter

LRIP	low rate initial production
MAIS	Major Automated Information System
MDA	Milestone Decision Authority
MDAP	Major Defense Acquisition Program
MRL	Manufacturing Readiness Level
NASA	National Aeronautics and Space Administration
NDAA	National Defense Authorization Act
NPS	Naval Post Graduate School
OIPT	Overarching Integrated Product Team
OSD	Office of the Secretary of Defense
PA&E	Program Analysis and Evaluation
PEO	Program Executive Officer
PM	Program Manager
PVPC	Photovoltaic Power Converter
RDT&E	Research, Development, Test, and Evaluation
S&T	Science and Technology
SDD	System Development and Demonstration, a phase in the DAS
SPO	System Program Office
T&E	Test and Evaluation
TD	Technology Development
TDS	Technology Development Strategy
TRA	Technology Readiness Assessment
TRL	Technology Readiness Level
USD(AT&L)	Under Secretary of Defense for Acquisition, Technology, and

LIST OF REFERENCES

- A Short History of The Naval Postgraduate School*,
<http://www.nps.edu/aboutnps/navigation/heritage.html>, [October 2004]
- American Heritage Dictionary of the English Language*, Fourth Edition, Houghton Mifflin Company, 2002
- Besser, David A., *Photovoltaic Power Conversion Technology: Reserved Backup Power*, (Unpublished Document, Atira Technologies, Los Gatos, CA: May 12, 2004)
- Chairman of the Joint Chiefs of Staff Manual (CJCSM) 3170.01, *Operation of the Joint Capabilities Integration and Development System*, dated 24 June 2003, Enclosure F paragraphs 1. and 2, (<http://www.teao.saic.com/jfcom/ier/documents/m317001.pdf>).
- Department of Defense Directive (DoDD) 5000.1, *The Defense Acquisitions System*, May 12, 2003
- Department of Defense Instruction (DoDI 5000.2), *Operation of the Defense Acquisition System*, May 12, 2003
- Department of Defense, *Technology Readiness Assessment (TRA) Deskbook*, September 2003
- Dept of Energy, Solar Energy Profile,
<http://www.eia.doe.gov/cneaf/solar.renewables/page/solarthermal/solarprofile.pdf>,
[October 2004]
- Future Combat Systems, *18 + 1 + 1 Overview*, Whitepaper, (Program Manager Unit of Action, 2005)
- Gansler, J.S., Memorandum as Forward to, Office of the Secretary of Defense Report on *Commercial Item Acquisition: Considerations and Lessons Learned*, (Washington D.C.: 2000).
- General Accounting Office, GAO/NSIAD-96-106, *Acquisition Reform: Efforts to Reduce the Cost to Manage and Oversee DOD Contracts*, (Washington, D.C.: 1996),
- General Accounting Office, GAO/NSIAD-97-48, *Acquisition Reform: DoD Faces Challenges in Reducing Oversight Costs*, (Washington, D.C.: 1997)
- Hamilton, Jason A., Sablan, Steve A., Whiteker, James S, *Logistical Impact Study of Photovoltaic Power Converter Technology to the United States Army and United States Marine Corps*, MBA Professional Report, Naval Postgraduate School, Monterey, CA: 2004

<http://ces.iisc.ernet.in/hpg/envis/olydoc712.html>, [October 2004]

<http://encyclobeamia.solarbotics.net/articles/photovoltaic.html>, [October 2004]

<http://inventors.about.com/library/inventors/blsolar2.htm>, [October 2004]

<http://peocscss.tacom.army.mil/pmCSS.html>, [May 2005]

<http://www.acq.osd.mil/actd/intro.htm#Introduction>, [April 2005]

<http://www.californiasolarcenter.org/photovoltaics.html>, [October 2004]

<http://www.mcs.drexel.edu/~crrres/Archimedes/Mirrors/Tzetzes.html>, [October 2004]

<http://www.uccs.edu/~energy/courses/160lectures/solhist.htm>, [October 2004]

<http://www.walter-fendt.de/ph11e/photoeffect.htm>, [October 2004]

https://lrcteams.monmouth.army.mil/QuickPlace/ipm/PageLibrary85256A2B0062C0F7.nsf/h_Toc/F8DED136FF17831985256B3E006CF4E0/?OpenDocument, May 2005.

Locher, Steve, *Atira Technologies and Raven Designs Solar Array Results and Conclusions From Kodiak, Alaska*, (Unpublished Information Paper, Raven Designs, November 11, 2004)

Locher, Steve, *Raven Designs*, (Unpublished Product Brochure, Raven Designs)

Mankins, John C., *Technology Readiness Levels*, White Paper, NASA, April 6, 1995

Matan, Stefan, *Mr. Matan's Personal Account*, (Unpublished Document, Atira Technologies, Los Gatos, CA: 2004)

Navy Cooperative Research Agreement, NPS and ATIRA, Low-Light Solar Charger, Draft

Norman,
<http://www.eco.utexas.edu/homepages/faculty/Norman/long.extra/Student.F99/solar/car.html>, [October 2004]

NPS At a Glance, <http://www.nps.edu/aboutnps/navigation/descNPS.html>, [October 2004]

Office of the Secretary of Defense, Acquisition, Technology, and Logistics, *Commercial Item Handbook*, , November 2001,

Perlin and Butti, http://www.californiasolarcenter.org/history_pv.html, [October 2004]

Perlin and Butti, http://www.californiasolarcenter.org/history_solarthermal.html, [October 2004]

Perlin and Butti, www.californiasolarcenter.org/history_passive.html, [October 2004]

Programs, 18 October 2004, <<http://www.nps.navy.mil/gsbpp/programs.htm>>, [October 2004]

Smith, http://www.solarenergy.com/info_history.html, [October 2004]

Wikipedia, http://en.wikipedia.org/wiki/Technology_Readiness_Level, [October 2004]

Wolf, Alexander, *Photovoltaic Power Conversion Technology Enhancements: Design a circuit that will track max pwr pt*, (Unpublished Document, Atira Technologies, Los Gatos, CA: 2004)

www.californiasolarcenter.org/history_passive.html, [October 2004]

www.encyclopedia.msn.com/encyclopedia_761562112/Sun.html, [October 2004]

www.m-w.com, [October 2004]

www.solarserver.de/lexikon/sonnenenergie-e.html, [October 2004]

www.usgs.gov/tech-transfer/what-crada.html

THIS PAGE INTENTIONALLY LEFT BLANK

INITIAL DISTRIBUTION LIST

1. Defense Technical Information Center
Ft. Belvoir, Virginia
2. Dudley Knox Library
Naval Postgraduate School
Monterey, California