

DoD Space Test Program
Secondary Payload Planner's Guide
For Use On The
EELV Secondary Payload Adapter



November 2004

Report Documentation Page

*Form Approved
OMB No. 0704-0188*

Public reporting burden for the collection of information is estimated to average 1 hour per response, including the time for reviewing instructions, searching existing data sources, gathering and maintaining the data needed, and completing and reviewing the collection of information. Send comments regarding this burden estimate or any other aspect of this collection of information, including suggestions for reducing this burden, to Washington Headquarters Services, Directorate for Information Operations and Reports, 1215 Jefferson Davis Highway, Suite 1204, Arlington VA 22202-4302. Respondents should be aware that notwithstanding any other provision of law, no person shall be subject to a penalty for failing to comply with a collection of information if it does not display a currently valid OMB control number.

1. REPORT DATE NOV 2004	2. REPORT TYPE N/A	3. DATES COVERED -	
4. TITLE AND SUBTITLE DoD Space Test Program Secondary Payload Planner's Guide For Use On The EELV Secondary Payload Adapter		5a. CONTRACT NUMBER	
		5b. GRANT NUMBER	
		5c. PROGRAM ELEMENT NUMBER	
6. AUTHOR(S)		5d. PROJECT NUMBER	
		5e. TASK NUMBER	
		5f. WORK UNIT NUMBER	
7. PERFORMING ORGANIZATION NAME(S) AND ADDRESS(ES) 377 ABW/HO 2000 Wyoming Blvd SE Ste D-2 Kirtland AFB, NM 87117-5606		8. PERFORMING ORGANIZATION REPORT NUMBER	
9. SPONSORING/MONITORING AGENCY NAME(S) AND ADDRESS(ES)		10. SPONSOR/MONITOR'S ACRONYM(S)	
		11. SPONSOR/MONITOR'S REPORT NUMBER(S)	
12. DISTRIBUTION/AVAILABILITY STATEMENT Approved for public release, distribution unlimited			
13. SUPPLEMENTARY NOTES The original document contains color images.			
14. ABSTRACT			
15. SUBJECT TERMS			
16. SECURITY CLASSIFICATION OF:			17. LIMITATION OF ABSTRACT
a. REPORT unclassified	b. ABSTRACT unclassified	c. THIS PAGE unclassified	UU
			18. NUMBER OF PAGES 22
			19a. NAME OF RESPONSIBLE PERSON

This Users Guide has been prepared by the Department of Defense Space Test Program, SMC Det 12/ST. This report has been reviewed by the Public Affairs Office (PAS) and is releasable to the general public.

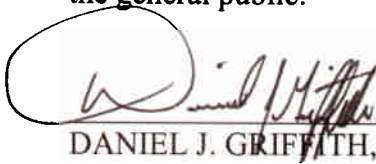
A handwritten signature in dark ink, appearing to read "Daniel J. Griffith", is written over a horizontal line. The signature is somewhat stylized and cursive.

DANIEL J. GRIFFITH, Lt Col, USAF
Acting Director, DoD Space Test Program

Point of Contact:
DoD Space Test Program
Spaceflight Mission Design Division
SMC Det 12/STX
DSN: 263-5505
Comm: (505) 853-5505
dodstp.rideshare@kirtland.af.mil

Table of Contents

1	ESPA OVERVIEW	5
1.1	DOCUMENT OVERVIEW	5
1.2	SYSTEM OVERVIEW.....	5
1.3	OVERVIEW OF STP SERVICES AND APL APPROVAL PROCESS.....	6
1.4	REFERENCE DOCUMENTS	6
1.5	ACRONYMS	7
2	ESPA SECONDARY PAYLOAD INTERFACES	8
2.1	SECONDARY PAYLOAD COORDINATE SYSTEM.....	8
2.2	MASS AND CG REQUIREMENTS.....	10
2.3	SECONDARY SATELLITE VOLUME	11
2.4	MECHANICAL INTERFACE	13
2.5	ELECTRICAL INTERFACE	14
3	ENVIRONMENT	15
3.1	PRE-LAUNCH.....	15
3.1.1	<i>Thermal / Humidity</i>	15
3.1.2	<i>Contamination</i>	15
3.2	LAUNCH	15
3.2.1	<i>Electromagnetic Compatibility</i>	15
3.2.1.1	SV Radiation Narrowband	15
3.2.1.2	SV Radiation Broadband.....	15
3.2.2	<i>Thermal</i>	15
3.2.3	<i>SPL Fundamental Frequency</i>	15
3.2.4	<i>Acceleration Load Factors</i>	15
3.2.5	<i>Random Vibration</i>	15
3.2.6	<i>Acoustics</i>	15
3.2.7	<i>Shock</i>	15
4	MISSION INTEGRATION AND DOCUMENTATION.....	16
4.1	MISSION INTEGRATION.....	16
4.1.1	<i>Schedule</i>	16
4.1.2	<i>Other Requirements and Constraints</i>	16
4.2	MISSION ANALYSES	16
4.2.1	<i>Coupled Loads Analysis (CLA)</i>	16
4.2.2	<i>RF Compatibility Analysis</i>	16
4.2.3	<i>Thermal Analysis</i>	17
4.2.4	<i>Separation and PLF Clearance Analysis</i>	17
4.2.5	<i>Acoustic Analysis</i>	17
4.2.6	<i>Payload Fairing Venting Analysis</i>	17
4.2.7	<i>Mission Analysis</i>	17
4.2.8	<i>Range Safety Analysis</i>	17
4.2.9	<i>EMI/EMC Analysis</i>	17
4.2.10	<i>Post-flight Data Analysis</i>	18
4.3	DOCUMENTATION	18
4.3.1	<i>Overall Documentation Requirements</i>	18
5	SAFETY	20
5.1	SAFETY REQUIREMENTS.....	20
5.2	DOCUMENTATION REQUIREMENTS.....	20
5.2.1	<i>Missile System Pre-launch Safety Package (MSPSP)</i>	20
5.2.2	<i>Secondary Spacecraft Launch Site Procedures</i>	20
5.2.3	<i>Radiation Data</i>	20

5.2.4	<i>Radio Frequency (RF) Data</i>	20
5.2.5	<i>Other Data</i>	20

APPENDIX A – SPACECRAFT QUESTIONNAIRE	21
--	-----------

LIST OF FIGURES

FIGURE 1 FULLY LOADED ESPA STACK ON EELV ILLUSTRATION	5
FIGURE 2 ESPA SOLID MODEL	8
FIGURE 3 ESPA SECONDARY PAYLOAD COORDINATE SYSTEM.....	9
FIGURE 4 STANDARD VEHICLE COORDINATE SYSTEM FOR EELV	9
FIGURE 5 ALLOWABLE SPACECRAFT MASS AND CENTER-OF-GRAVITY ON ESPA.....	10
FIGURE 6 SPL ENVELOPE DEFINITION	11
FIGURE 7 ESPA STAY-OUT ZONE DEFINITION.....	12
FIGURE 8 ESPA SECONDARY PAYLOAD INTERFACE	13

LIST OF TABLES

TABLE 1 SPL ELECTRICAL INTERFACE	14
TABLE 2 TYPICAL DOCUMENTATION/REQUIREMENTS FOR SECONDARY SATELLITES.....	18

1 ESPA Overview

1.1 Document Overview

The Evolved Expendable Launch Vehicle (EELV) Secondary Payload Adapter (ESPA) Secondary Payload Planner's Guide is published by the DoD Space Test Program (STP) Office, Space and Missiles System Center, Kirtland AFB, NM, to provide interface information for secondary satellites. This document should be used in conjunction with the EELV Standard Interface Specification (SIS) and each launch vehicle provider's Planner Guides.

Note that the term "secondary payloads" refers to complete satellites. The terms "secondary payloads", "secondary satellites" and "secondaries" are used interchangeably throughout this document.

1.2 System Overview

ESPA is a structure developed by AFRL and STP to provide optional transportation for up to six secondary payloads (SPLs) as a ride-along on the EELV as shown in Figure 1. The SPLs are mounted radially on the ESPA. ESPA is installed between the EELV-Medium (62.01" diameter bolt pattern) Standard Interface Plane (SIP) and the primary payload, passing EELV electrical and mechanical interfaces to the primary payload in a configuration identical to that of the baseline EELV. It provides all required thermal, mechanical, and electrical interfaces to the secondary payloads (SPLs) in conjunction with the basic launch service. Each SPL is deployed from the ESPA at a predetermined point along the primary mission trajectory. SPLs are deployed on a strict basis of non-interference with the primary mission.

Figure 1 - Fully Loaded ESPA Stack On EELV Illustration

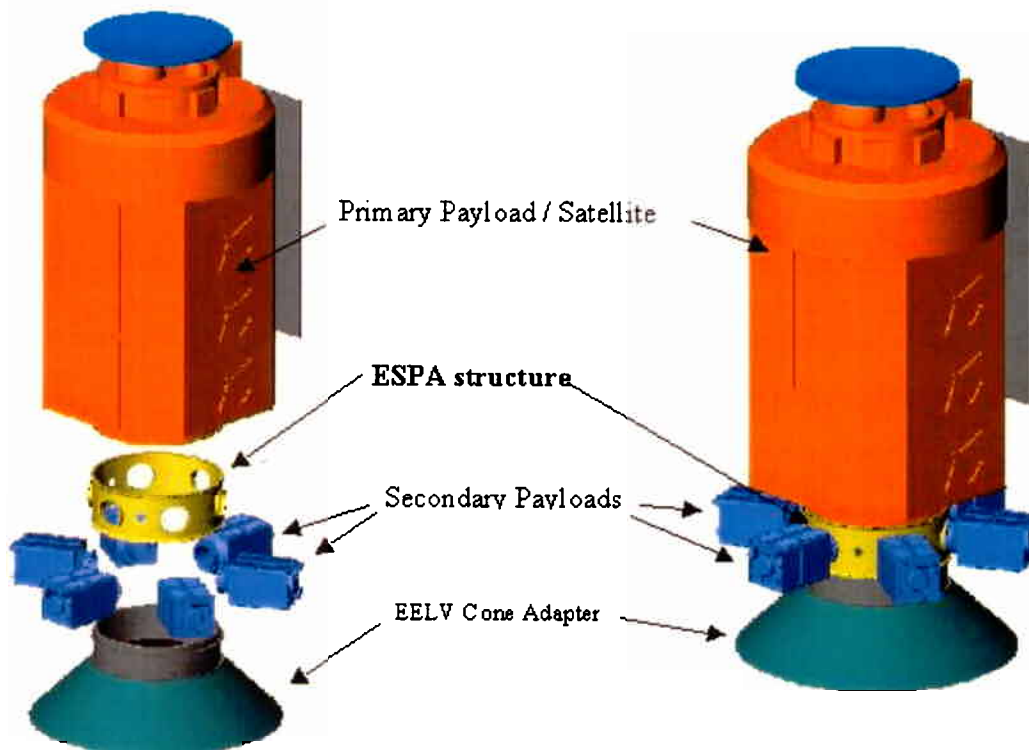

1.3 Overview of STP Services and SPL Approval Process

1.3.1 Services

1. STP will provide the ESPA structure and all mission unique electrical harnesses.
2. STP will provide SPL integration facilities at the launch site. All SPL GSE is the responsibility of the SPL organization.

1.3.2 Approval Process

1. Acceptance of the SPL is subject to approval of STP, the EELV SPO and the primary payload SPO (IAW reference document #6.)
2. SERB Payloads will be identified by STP as possible candidates for transportation on an ESPA.
3. Reimbursable payloads will contact STP for possible flight on an ESPA.
4. All SPLs must complete the spacecraft questionnaire as the first step in the ESPA manifest process. This includes the initial SPL requirements, orbit requirements, interface details, etc. Appendix A includes a sample questionnaire and further guidance.
5. Manifesting of SPLs will be considered only for those EELV missions that have excess performance and weight margin. STP may withdraw SPLs if any of these margins are unexpectedly reduced.
6. Any deviation from this guide will be approved by STP on a case-by-case basis and must be annotated in the MOA.

1.4 Reference Documents

1. EELV Standard Interface Specification – Version 6.0
2. Delta IV Payload Planners Guide – Current Version
<http://www.boeing.com/defense-space/space/delta/delta4/guide/index.htm>
3. Atlas Launch System Mission Planner's Guide – Current Version
http://www.ilslaunch.com/ILS/launch_services/index.html#MISS
4. Range Safety Requirements Manual - AFSPCMAN 91-710
5. Mil Std 1540 Rev E
6. Implementation Plan for Rideshare Mission on EELV DoD Assets, 21 Jul 04

1.5 Acronyms

AFRL	Air Force Research Laboratory
CAD	Computer Aided Drafting
CCAFS	Cape Canaveral Air Force Station
CG	Center-of-Gravity
CLA	Coupled Loads Analysis
EED	Electro-Explosive Device
EELV	Evolved Expendable Launch Vehicle
EGSE	Electrical Ground Support Equipment
EMC	Electromagnetic Compatibility
EMI	Electromagnetic Interference
ESD	Electrostatic Discharge
ESPA	EELV Secondary Payload Adapter
GN ₂	Gaseous Nitrogen
GSE	Ground Support Equipment
GTO	Geosynchronous Transfer Orbit
ICD	Interface Control Document
IRD	Interface Requirements Document
LEO	Low-Earth Orbit
LV	Launch Vehicle
LVC	Launch Vehicle Contractor
MSPSP	Missile System Prelaunch Safety Package
NTE	Not To Exceed
PDLC	Preliminary Design Load Cycle
PL	Payload
PLF	Payload Fairing
PPL	Primary Payload
RF	Radio Frequency
RPO	Range Protection Officer
SIP	Standard Interface Plane
SEIP	Standard Electrical Interface Plane
SIS	Standard Interface Specification
SPO	System Program Office
SPL	Secondary Payload
SSIP	Secondary Standard Interface Plane
STP	DoD Space Test Program
SV	Space Vehicle
USAF	United States Air Force
VAFB	Vandenberg Air Force Base

2 ESPA Secondary Payload Interfaces

ESPA is a cylindrical aluminum structure that duplicates the EELV Standard Interface Plane (SIP) for the primary payload, and provides up to six slots for deployment of secondary satellites. ESPA is 24 inches high, and is depicted below in Figure 2.

Figure 1 - ESPA Solid Model



2.1 Secondary Payload Coordinate System

The coordinate system that will be used by the SPLs is a right-handed coordinate system with the origin located at the Secondary Standard Interface Plane (SSIP) (the outer edge of the attachment ring for the secondaries) and mid-height of ESPA. The SPL local coordinate system is depicted in Figure 3, referenced with respect to the SSIP. The axial, or longitudinal, direction of the SPL lies along the separation direction of the secondary payload, with the positive direction starting from the SSIP and pointing towards the fairing. This direction will be referred as the $+X_{spl}$, where the subscript "spl" refers to the secondary payload. The $+Y_{spl}$ axis corresponds to the longitudinal (+X axis) of the EELV launch vehicle, or the LV thrust direction. The $+Z_{spl}$ axis finishes the right-handed coordinate system, and is perpendicular to the plane of the $+X_{spl}$ and $+Y_{spl}$.

Figure 2 - ESPA Secondary Payload Coordinate System

Note: Origin is located at center of ESPA flange in SPL interface plane.

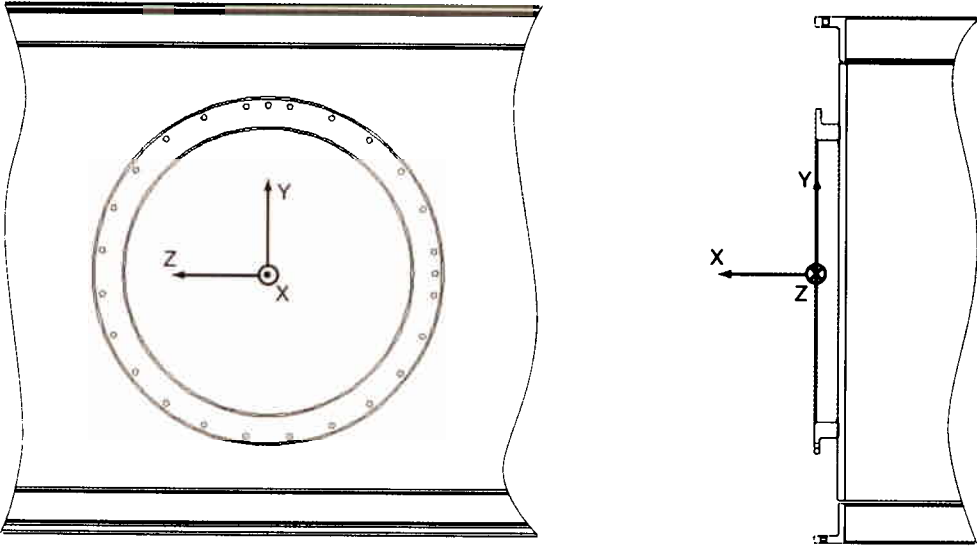

For reference, the EELV standard vehicle coordinate system is shown in Figure 4. The origin is at the center of the SIP with the positive X-axis is along the centerline of the vehicle and point toward the nose or top of the LV. Also, the axial axis is defined as the X-axis with the Y-axis and Z-axis denoted by the lateral axes.

Figure 3 - Standard Vehicle Coordinate System for EELV

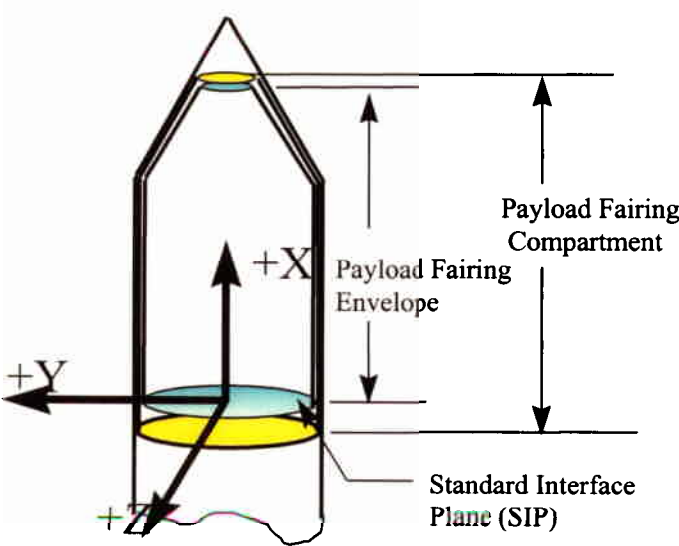

2.2 Mass and CG Requirements

Each SPL shall not exceed a mass of 400 lbs. Each SPL's center of gravity (cg) cannot exceed 20 inches from the SSIP. Note that the height of the separation system is within the 20 inch offset. Figure 5 is a curve of the mass versus cg requirement for SPLs. The mass increase may be accommodated with a corresponding decrease in cg with the prior approval of STP.

In order to keep ESPA balanced, SPL may be given a mass target (determined by STP) that must be met (vs. a mass NTE.)

Figure 4 - Allowable Spacecraft Mass and Center-of-Gravity on ESPA

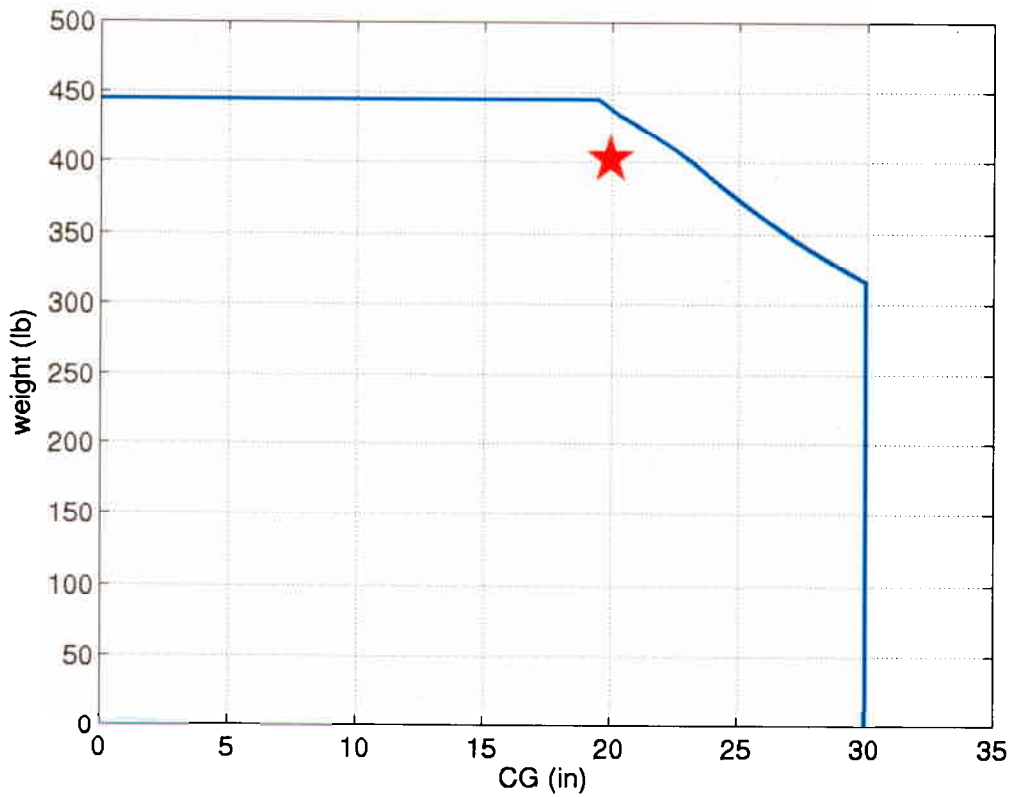

2.3 Secondary Satellite Volume

The total volume allocated to an SPL is 24 inches x 28 inches x 38 inches. This volume must include the separation system and a “stayout zone” (2.5 inch) in order to facilitate SPL-to-ESPA mating operations. The “stayout zone” is required between the ESPA forward and aft flanges, and the body of the SPL. Figure 7 illustrates the volume allocation including the “stay-out-zone.”

The standard ESPA envelope consists of 38 inches along the $+X_{spl}$, 14 inches along the $\pm Z_{spl}$ axis centered about the origin, and 12 inches in the $\pm Y_{spl}$ centered about the origin as shown in Figure 6. Minor local excursions to this envelope may be permissible upon approval by STP. Excursions aft of the SSIP, i.e. into the ESPA internal volume, must be coordinated and approved by STP.

Figure 6 - SPL Envelope Definition

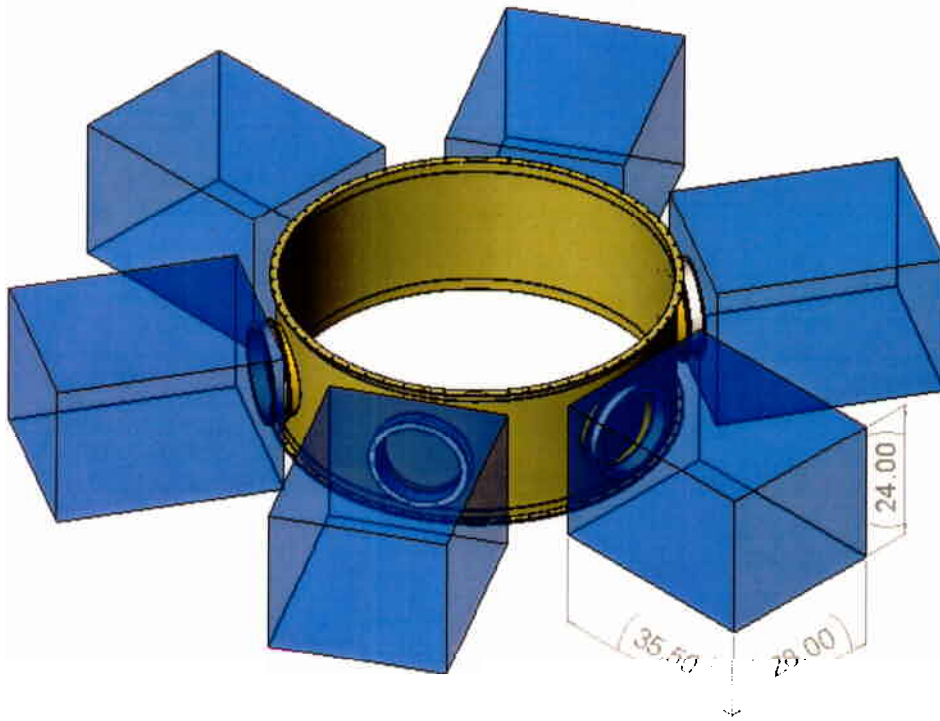
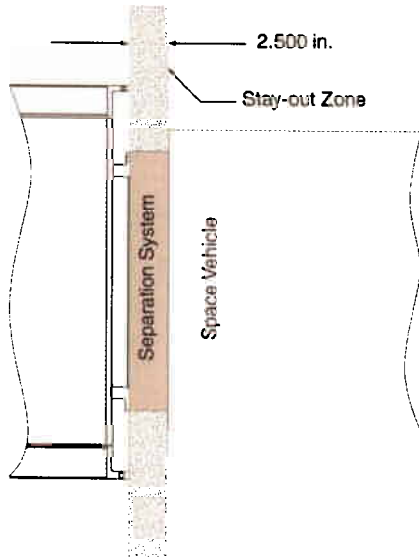

Figure 7 - ESPA Stay-out Zone Definition



2.4 Mechanical Interface

It is incumbent on each SPL to match the standard interface to the satellite or provide a payload attach fitting from the standard interface to the attachment point of their satellite. A drill template will be provided, if requested, to ensure matched hole patterns.

A detailed view of the SSIP is shown in Figure 8. This plane consists of a flange for the SPL, which is made of forged aluminum. The ring has a diameter of 15 inches from the SSIP center to bolt-hole center. The bolt pattern consists of 24 - #10 holes and are spaced every 15 degrees around the ring. The zero degree (0°) point of the ring lies along the $+Y_{spl}$ direction in the ESPA coordinate system.

Figure 8 - ESPA Secondary Payload Interface

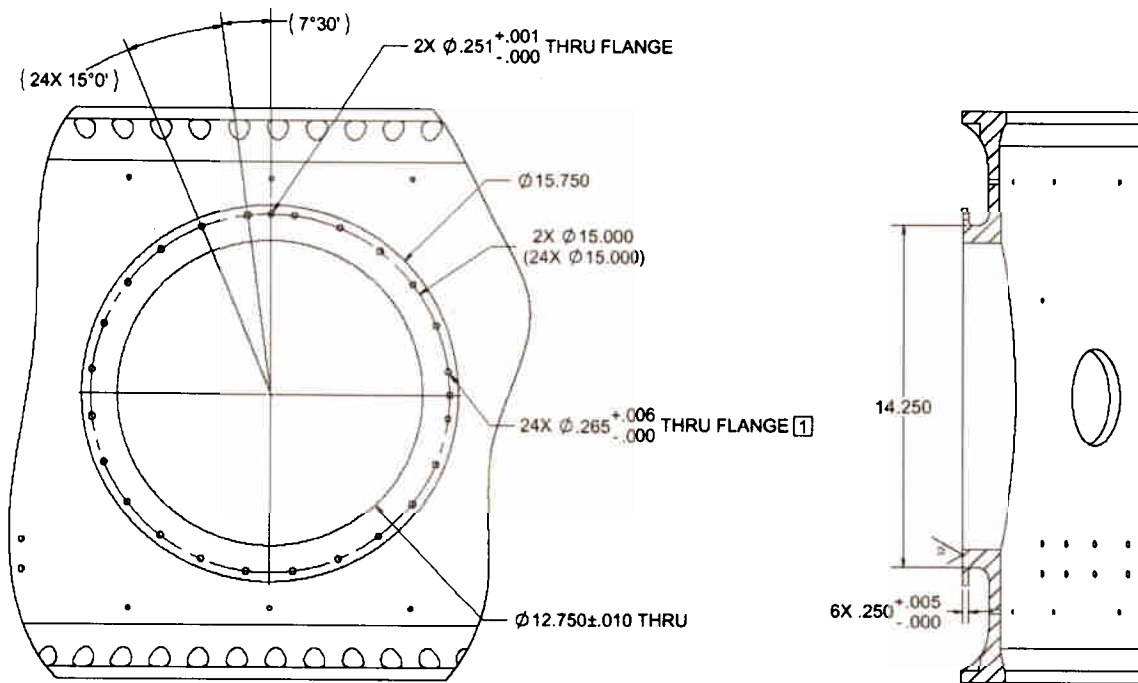

[1] DRILL HOLE PATTERN USING DRILL TEMPLATE AFRL003-009 (6X).

2. SEE DRAWING #98002 (CURRENT REV) FOR TOLERANCES.

2.5 Electrical Interface

STP will provide pass through electrical interconnections and cables from the EELV/ESPA standard electrical interface panel (SEIP) to SPL electrical interfaces and separation systems. Electrical cable harness connector part numbers for the SPL/ESPA interface will be decided on a mission specific basis. If secondary payload manufacturers have a preference as to the connectors to be used, this will be taken into consideration during the ESPA harness design process. The ESPA system shall provide umbilical electrical interconnection beginning at T-0 umbilical installation. All SPL-provided signals and power will be handled as unclassified data. At the time SPL/LV electrical connectors are to be separated, the current on any line shall be no greater than 10 milli-amps. This applies to SPL/ESPA interfaces in the T-0 umbilical and in SPL separation connectors.

The nominal SPL electrical interface is shown in Table 1. The only guaranteed signals are the redundant separation signals. The 8 lines providing connectivity to the EGSE are contingent on Primary Payload and other SPL harness requirements.

It is an STP requirement that 2 pins in the SV electrical connector be reserved to accommodate a breakwire indicator so the LV can record a positive separation signal for the SPL.

The SV separation sense can be accomplished by whatever method the SV chooses, i.e. breakwire separation switch, etc.

Table 1 - SPL Electrical Interface

SPL Electrical Interface – Ground Connections	SPL Electrical Interface – Separation Signals
Battery Charge/Power +	Primary Separation +
Battery Charge/Power -	Primary Separation -
Battery Voltage Sense +	Redundant Separation +
Battery Voltage Sense -	Redundant Separation -
Data/Telemetry 1 +	
Data/Telemetry 1 -	
Data/Telemetry 2 +	
Data/Telemetry 2 -	
	SPL Electrical Interface – LV Connections
	LV Separation Sense +
	LV Separation Sense -
	SPL Electrical Interface – Breakwires
	SV Separation Sense +
	SV Separation Sense -

3 Environment

3.1 Pre-Launch

3.1.1 Thermal / Humidity

Thermal /humidity requirements will be determined on a mission unique basis. SPL will be required to meet thermal/humidity requirements of the primary payload, and of each other (if applicable), while the payloads are stacked together. In addition, secondary payloads shall not impose thermal or humidity requirements on the primary payload. Fairing temperature characteristics are per the EELV SIS.

3.1.2 Contamination

Contamination requirements will be determined on a mission unique basis. SPLs will be required to meet contamination requirements of the primary payload, and of each other (if applicable). Further, SPLs shall not impose contamination requirements on the primary payload.

3.2 Launch

3.2.1 Electromagnetic Compatibility

3.2.1.1 SV Radiation Narrowband

The secondary payload intentional and unintentional radiated emissions shall not exceed the maximum allowable emissions curve as stated in the SIS. Information on the SV emitters and receivers (power, frequency, E-field levels, and sensitivity of receivers) shall be supplied to the Launch Vehicle Contractor (LVC) upon request.

3.2.1.2 SV Radiation Broadband

The SV unintentional broadband radiated emissions shall not exceed the maximum allowable emissions curve as stated in the SIS.

3.2.2 Thermal

The maximum expected temperatures in the EELV fairing will be specified in the SIS.

3.2.3 SPL Fundamental Frequency

The first fundamental frequency of all secondary payloads shall be greater than 35 Hz, unless otherwise waived by STP.

3.2.4 Acceleration Load Factors

The SPL shall be designed to withstand a 10.0 g load in the axial and lateral direction, applied at the cg. For design purposes these loads should be applied simultaneously.

3.2.5 Random Vibration

The maximum predicted random vibration environment for an SPL will be provided when the SPL is manifested.

3.2.6 Acoustics

Acoustic environment in an EELV fairing will be specified in the SIS.

3.2.7 Shock

The maximum predicted shock environment generated by the launch vehicle will be specified in the SIS. SPLs should note that shock may also be generated by the primary payload. This level will be provided when the SPL is manifested.

4 Mission Integration and Documentation

4.1 Mission Integration

4.1.1 Schedule

Secondary payload mission integration is managed by STP. The mission integration process starts no later than L-36 months so that the ESPA and the SPLs are ready to enter the standard EELV integration process at L-24 months. STP will pre-coordinate the ESPA flight with the primary payload prior to manifesting any secondary payloads.

No later than L-36 months, the SPL will submit a payload questionnaire (contained in Appendix A) to STP. STP will evaluate the SPL requirements and target a launch opportunity. Once an ESPA mission is developed, STP will contract with the EELV provider to conduct mission specific special studies to determine the mission's feasibility. The SPL shall be prepared to support these studies with orbit requirements, SV mass properties data, and an SV finite element model.

STP will manifest the SPLs and ensure they meet the mission integration schedule. The SPLs shall meet all mission schedules and shall not impact the primary payload in any negative manner. That is, the primary payload drives the launch schedule and the SPL must meet this schedule. The SPL should be ready to enter the mission specific (typically 36 months) integration schedule per the mission unique LV schedule. On mission where the primary payload is an STP mission, exceptions can be made for SPL delays on a case-by-case basis.

4.1.2 Other Requirements and Constraints

In order to keep ESPA balanced, SPL may be given a mass target (determined by STP) that must be met (v. mass NTE). In addition, "space-qualified" mass models, with separation systems, may be required should the SPL not be available for flight.

After encapsulation there will be no standard access to SPLs on ESPA.

The SPL must prepare and submit a mission assurance and risk reduction/mitigation plan. In addition, the SPL must provide flight readiness certification of their flight hardware and shall participate in all SMC readiness reviews, as required.

4.2 Mission Analyses

Each EELV contractor will perform mission analyses according to the respective LV Mission Planner's Guide. As an SPL on an EELV mission, the SPL shall be prepared to provide SV data inputs to these analyses. Most of these analyses that are performed by each EELV provider are given below. Please note that although this list is comprehensive, each ESPA mission has unique requirements that may make additional analysis necessary.

4.2.1 Coupled Loads Analysis (CLA)

Each EELV provider will perform a coupled dynamic-loads analysis to define flight loads, accelerations, and deflections of the launch vehicle and spacecraft structures. This analysis is used to help the satellite manufacturer in the design process so that areas of concern can be addressed up-front thereby reducing major design costs later in the spacecraft design cycle. Typical launch vehicle events that will be simulated during CLA include liftoff, air-loads, engine starts and engine cut-off. However, not all events may be analyzed if flight experience or class analyses show them to be benign events.

Outputs from the CLA include maximum accelerations and interface loads at selected nodes of the spacecraft. Also, as part of this analysis, worst-case spacecraft-to-fairing dynamic clearance is determined. Each spacecraft manifested on ESPA must provide dynamic models in accordance with specific EELV provider required format.

4.2.2 RF Compatibility Analysis

Each EELV provider will perform a RF compatibility analysis to verify that spacecraft RF sources are compatible with the launch vehicle telemetry and tracking beacons. Typical systems that will be analyzed are S-band telemetry

systems, C-band tracking systems and flight termination systems. A comprehensive report will be published describing the link requirements and results, which will include both airborne and ground requirements. This report will include any RF interference from each secondary spacecraft.

4.2.3 Thermal Analysis

Each EELV provider will perform thermodynamic analysis of the thermal environments imposed on the SPL from pre-launch conditions up until the spacecraft is separated from the launch vehicle. Each SPL is required to provide a payload thermal math model, geometric math model, and spacecraft power dissipation timeline for this analysis. The results from this analysis can be used to design thermal interfaces; it can also impact mission operations by limiting the thermal environment imposed on the SPL.

Typically, these models should be less than 400 nodes each, and each EELV provider may request these models in various formats. Information to be included in this model includes illustrations of all surfaces, a description of surface properties, and correspondence between the nodes of the thermal model and geometric model. This model should include illustrations of all thermal modeling; detailed component power dissipation for pre-launch, ascent, and on-orbit mission phases; steady-state and transient test case boundary conditions, output minimum allowable component temperature limits; and internal spacecraft convection and radiation modeling.

4.2.4 Separation and Payload Fairing (PLF) Clearance Analysis

A PLF clearance analysis will be performed for the PLF jettison to verify clearances of SPL with respect to the fairing. A separation analysis is also performed for the primary separation with respect to ESPA and the LV, as well as the SPLs with respect to the LV. This analysis determines the minimum relative velocity needed before any LV maneuvers are performed; it will also make sure that the LV upper stage will not re-contact any of the secondaries after being separated.

4.2.5 Acoustic Analysis

Once the size, shape and overall dimensions of the spacecraft are defined, a detailed mission specific acoustic analysis can be performed. The analysis of the acoustic environment determines the effects of noise reduction of the PLF, the "fill factor" of the SPLs, and the acoustic environment for the specific ESPA mission.

4.2.6 Payload Fairing Venting Analysis

A venting analysis on the ascent phase may be performed to determine mission-specific pressure profiles. If required, the SPLs must provide a spacecraft venting configuration and any specific PLF requirements, such as thermal shields. The output of this analysis will be provided to the secondary satellites and will include PLF pressure profiles and depressurization rates as a function of flight time.

4.2.7 Trajectory Analysis

Mission analysis is typically the first step in the mission planning process, and requirements should be submitted as soon as the SPLs have been manifested on ESPA. Initially, this analysis will use the best available mission requirements (such as spacecraft weight, orbit requirements, etc.), and is primarily intended to uncover any unforeseen problems. The analysis will provide information on launch vehicle environment, performance capability (propellant margin and reserve), sequencing, orbit dispersion, and trajectory. The trajectory design ensures that all spacecraft, launch vehicle, and range-imposed environmental and operational constraints are met during flight. The trajectory is also used to develop mission-targeting constraints (orbit parameters) and represents the flight trajectory (injection accuracy). The SPL shall not affect the primary payload's mission orbit requirements.

4.2.8 Range Safety Analysis

To ensure compliance with Range Safety Requirements Manual (AFSPCMAN 91-710), the EELV provider will analyze the flight plan for a particular ESPA mission. Typically, this submittal will occur one year before the launch for the initial flight plan, and then approximately 45 days prior to launch for the second. This information includes nominal and non-nominal trajectories and impact locations of jettisoned hardware. Each EELV contractor will prepare a range support or operations plan that will include launch operations configurations, organizational roles and responsibilities, mission rules, mission control team procedures, and go/no-go criteria.

4.2.9 EMI/EMC Analysis

An EMI/EMC analysis is performed to ensure compatibility between all avionics equipment, primary payload and the SPLs. It will cover requirements for bonding, lightning protection, wire routing and shielding, and procedures.

This analysis will also include intentional and unintentional RF sources to conform to the 6-dB margins with respect to all general EMI/EMC requirements. Also, this analysis will include an electro-explosive device (EED) RF susceptibility analysis performed to range requirements.

4.2.10 Post-flight Data Analysis

Each EELV provider will perform post-flight data analysis on each particular ESPA mission. This analysis will verify the LV's performance from available flight data. In addition to the LV performance evaluation, the post-flight data includes an assessment of the injection conditions (in terms of orbital parameters and deviations from the target values) and spacecraft separation attitude and rates. Also, this report will document the payload environments, including primary and secondary satellites, to the extent in which the LV was instrumented. This data may include shock, acoustic, vibration or interface loads depending on sensor use.

4.3 Documentation

All SPLs manifested on ESPA will have to submit documentation to the LV provider/mission integrator in a timely fashion. These documents will represent the primary communication for issues, such as secondary mission requirements, safety data, etc., to the various support agencies working on the particular mission. Each SPL will provide a single individual to act as the interface with the ESPA mission integrator. All data, whether formal or informal, shall be routed through this single-point interface.

4.3.1 Overall Documentation Requirements

Typical documentation that will be required for SPLs is listed in Table 2. The mission manager shall provide the specific document requirements once ESPA has been manifested on a particular mission.

Table 1 - Typical Documentation/Requirements for Secondary Satellites

Item	
1	<p><u>Spacecraft Questionnaire</u> <i>The spacecraft questionnaire is the first step in the ESPA manifest process. It should include the initial SPL requirements, orbit requirements, interface details, etc. The list is specified in Appendix A and contains a set of questions whose answers will preliminarily define the interfaces and requirements at time of preparation.</i></p>
2	<p><u>Spacecraft Dynamic Models</u> <i>Spacecraft mathematical model is required for each SPL to be used in coupled-loads analysis; see Section 4.2.1 for more information on CLAs.</i></p>
3	<p><u>Interface Requirements Document</u> <i>Each SPL is required to submit an Interface Requirement Document (IRD) or similar document for input into the Interface Control Document (ICD). The IRD is used to define technical and functional requirements imposed by the spacecraft to the launch vehicle. Information typically includes:</i></p> <ol style="list-style-type: none"> 1) Mission Requirements which includes orbit parameters, launch window parameters, separation functions, and any special trajectory requirements, such as thermal maneuvers and separation over a telemetry and tracking ground station; 2) Spacecraft Characteristics which includes physical envelope, mass properties, dynamic characteristics, contamination requirements, acoustic and shock requirements, thermal requirements, and any special safety issues; 3) Mechanical and Electrical Interfaces which includes spacecraft mounting constraints, spacecraft access requirements, umbilical power, command and telemetry, electrical bonding, and electromagnetic compatibility (EMC) requirements; 4) Mechanical and Electrical Requirements for Ground Equipment and Facilities which includes spacecraft handling equipment, checkout and support services, prelaunch and launch environmental requirements, spacecraft gases and propellants, spacecraft radio frequency (RF) power, and monitor and control requirements; 5) Test Operations which includes spacecraft integrated testing, countdown operations, and checkout and launch support.
4	<p><u>Fairing Requirements</u> <i>Any special fairing requirements should be specified in the questionnaire and updated through the mission process; this includes any access to the spacecraft after fairing encapsulation, internal fairing temperatures, surface sensitivities, etc. Final spacecraft requirements are needed to support the mission-specific fairing modifications during production.</i></p>

5	<p><u>Spacecraft Test Documents</u> Each SPL is required to document the test plan (e.g., static loads, vibration, acoustics, shock) for the spacecraft. This plan should include the approach used to perform qualification and acceptance testing for the satellite. This plan should be a general test philosophy and an overview of system-level testing to demonstrate adequacy of the spacecraft for flight. This will include test objectives, test configurations, test methods, and schedule. Test reports will also be required once these tests have been performed. The report should summarize all performed tests to verify the adequacy of the satellite structure for flight loads. For the satellite structural systems that were not verified by tests, a structural-loads analysis report shall be provided documenting the analyses performed and the resulting margins of safety.</p>
6	<p><u>Spacecraft Drawings</u> All SPLs are required to submit drawings showing the configuration, shape, and dimensions of their satellite. Though not a requirement, it is preferred that the first draft be submitted with the spacecraft questionnaire. These drawings should specify a coordinate system relative to ESPA and list any special clearance requirements. The drawings should be sent via CAD media.</p>
7	<p><u>Launch Window</u> Each SPL is required to specify the window opening (to nearest minute) and closing (to nearest minute) times for any given day. The final window data should extend for at least two weeks beyond the scheduled launch date. Launch windows should be constrained to a few hours. Note that the launch window will be constrained from the primary payload's mission and the secondary payload's need to fit within this launch window.</p>
8	<p><u>Missile System Pre-launch Safety Package (MSPSP)</u> Before any SPL can use the launch facilities and resources (including launch), an MSPSP must be prepared and submitted. The MSPSP is a data package that provides detailed technical data on all hazardous items including drawings, schematics, and assembly and handling procedures. The major categories of hazardous systems are ordnance devices, radioactive material, propellants, pressurized systems, toxic materials and cryogenics, and RF radiation. More specifics on the MSPSP can be found in the AFSPCMAN 91-710.</p>
9	<p><u>Radio Frequency Radiation</u> Each SPL is required to specify the RF transmitted by the spacecraft during ground processing and launch. Inputs include the RF characterizations (power levels, frequencies, duration, frequency bandwidth etc.), locations and checkout requirements (open-loop, closed-loop, pre-launch, ascent phase, etc.)</p>
10	<p><u>Mission Requirements</u> Each SPL will submit mission requirements (spacecraft mass, orbit requirements, tracking requirements) in a timely fashion throughout the mission integration process. The first submittal of mission requirements will be accomplished via the spacecraft questionnaire. Subsequent submittals will occur throughout the mission integration process and will be solidified at ESPA manifest on an EELV mission.</p>
11	<p><u>Range or Network Support</u> If there are special or unique range and network support requirements for the SPL, then the spacecraft agency must submit operational configuration, communication, tracking, and data flow requirements. This information is needed to support the EELV provider's preparation of the document arranging range and network support.</p>
12	<p><u>Spacecraft Launch Operations Plan</u> Each SPL is required to provide STP a detailed understanding of the launch site activities and operations. This should include</p> <ol style="list-style-type: none"> 1) Detailed sequence & time span of all spacecraft-related launch site activities including: ground equipment, installation, facility installation & activities, spacecraft testing & spacecraft servicing 2) Recycle requirements 3) Restrictions to include launch site activity limitations, constraints on launch vehicle operations, security requirements & personnel access limitations & safety precautions 4) Special requirements include handling of radioactive materials, security & access control 5) Support requirements to include personnel, communications & data reduction 6) Launch & flight requirements for real-time data readout, postflight data analysis, and data distribution, post-flight facilities
13	<p><u>Spacecraft Integration Procedures</u> Each SPL must specify any handling constraints, environmental constraints, personnel requirements, equipment requirements, etc. for their satellite. This information should include all operations procedures that are accomplished at the launch site. The EELV provider for launch site preparations will use the data, and any hazardous procedures should follow from Section 0.</p>

14	<p>Spacecraft Mass Properties</p> <p>Each SPL is required to report their respective spacecraft mass properties. This includes all the masses that will separate or be retained, the center-of-gravity (cg) location for the same masses, changes in cg due to any appendage deployment, moments of inertia, products of inertia, and propellant slosh models. The values shall include the nominal values and 3σ uncertainties.</p>
----	---

5 Safety

This section describes the safety requirements that all SPLs must comply with in order to be launched at Cape Canaveral Air Force Station (CCAFS) or Vandenberg Air Force Base (VAFB). More detailed information will be provided once a candidate mission is chosen for the secondary satellites.

5.1 Safety Requirements

All pre-launch operations of the SPL must meet safety requirements. The United States Air Force (USAF) is responsible for overall safety at CCAFS and VAFB and has well established safety requirements. If the secondary satellites use any Astrotech facilities at CCAFS or VAFB, they must comply with the Astrotech safety policies. The same holds true for any operations that will be conducted at Spaceport Systems International (SSI) facilities.

Each EELV contractor/mission integrator will help facilitate the working of these documents with the appropriate range. The Space Wing safety organizations encourage the SPL organizations to coordinate with them to generate a tailored version of the Range Safety Requirement Manual (AFSPCMAN 91-710) for their prospective program.

5.2 Documentation Requirements

All satellites are required to submit safety documentation containing detailed information on all hazardous systems and any associated operations. Satellites that will launch from CCAFS or VAFB must comply with AFSPCMAN 91-710. The documentation of these hazards is briefly described below.

5.2.1 Missile System Pre-launch Safety Package (MSPSP)

The MSPSP is a data package that provides detailed technical data on all hazardous items. This includes all design, test, and operational considerations. Therefore, any specific ground support equipment (GSE) that will be used by any secondary satellites must be documented in this package. The content of the MSPSP can be found in AFSPCMAN 91-710. The MSPSP must be approved by Range Safety before any secondary satellite element reaches the launch site.

5.2.2 Secondary Spacecraft Launch Site Procedures

Space Wing safety must approve all processing procedures that includes hazardous operations. These procedures must be documented and approved by the appropriate safety officer.

5.2.3 Radiation Data

All emitters of ionizing and non-ionizing radiation must submit documentation to the Air Force safety agency. Those systems producing non-ionizing radiation will be designed and operated so those hazards to personnel are the lowest practical level. The required documentation will depend on location, use, and type of emitter.

5.2.4 Radio Frequency (RF) Data

Before any SPL is allowed to radiate RF emissions on the pad, permission must be secured from the Range Protection Officer (RPO). The required data include descriptions of the equipment, procedures, and data forms on the personnel who will be using the procedures. Also, an RF ordnance hazard analysis must be performed, documented, and submitted to confirm that the payload systems and the local RF environment present no hazards to ordnance on the spacecraft or launch vehicle.

5.2.5 Other Data

Each EELV provider can have slightly different safety requirements and LV provider specific data requirements will be obtained once a secondary satellite is manifested. Some of these data requirements are specified in the prospective LV provider's planner's guides.

Appendix A – Spacecraft Questionnaire

To facilitate a quicker manifest on ESPA, the SPL should submit the spacecraft questionnaire as soon as possible. This questionnaire is necessary in order for STP to assess which SPLs have similar mission requirements and would be compatible on the same ESPA mission. Typically, the questionnaire is required at least 3 years before a target launch opportunity, since all SPLs must be manifested on ESPA before ESPA can be manifested on one of the EELV missions. Not all questions will be feasible to answer early in the process but the SPLs should provide as much information as possible to STP.

ESPA Secondary Payload Questionnaire

Mission Name: _____

Mission Sponsor: _____

Mission Integration

1. Initial Launch Capability
2. Program Schedule/Major Milestone Dates
3. Frequency Approval Status

Orbit Definition

1. Inclination
2. Perigee
3. Apogee
4. Launch Window Constraints (Sun Angle, Eclipse, Ascending Node)

Physical Characteristics

1. Dimensions/Dimensioned Drawing
2. Mass and c.g. location (margin values)
3. Moments and Products of Inertia
4. Coordinate System
5. Fundamental Frequencies (Axial and Lateral)
6. Separation System Characteristics
7. Fairing Access Requirements

Electrical Characteristics

1. Required number and type of electrical signals from LV.
2. Required number and type of ground umbilical wires.
3. Interface connector part number.
4. Transmitter frequency and power.

Environmental Requirements

1. Cleanliness Requirements
2. Temperature Requirements
3. Humidity Requirements

Processing Facility Requirements

1. Does the SPL need access to SV system test facility?
2. When does the SV plan on arriving at the launch site?
3. What are the SV and GSE space requirements at the launch site?
4. What are the security requirements at the launch site?

Safety Concerns

1. What ordnance devices are on the SV?
2. What type of pressure vessels are on the SV? At what pressure?
3. Does the SV contain any hazardous materials? If so, list type and quantity.
4. Does the SV contain any radioactive devices?