

Where is the Heavy-Light Organization in the Army's Future Force?

**A Monograph
by
LTC Jeffrey D. Ingram
United States Army**



**School of Advanced Military Studies
United States Army Command and General Staff College
Fort Leavenworth, Kansas**

AY 04-05

REPORT DOCUMENTATION PAGE

Form Approved
OMB No. 074-0188

Public reporting burden for this collection of information is estimated to average 1 hour per response, including the time for reviewing instructions, searching existing data sources, gathering and maintaining the data needed, and completing and reviewing this collection of information. Send comments regarding this burden estimate or any other aspect of this collection of information, including suggestions for reducing this burden to Washington Headquarters Services, Directorate for Information Operations and Reports, 1215 Jefferson Davis Highway, Suite 1204, Arlington, VA 22202-4302, and to the Office of Management and Budget, Paperwork Reduction Project (0704-0188), Washington, DC 20503

1. AGENCY USE ONLY (Leave blank)		2. REPORT DATE 052605	3. REPORT TYPE AND DATES COVERED Monograph	
4. TITLE AND SUBTITLE Where is the Heavy-Light Organization in the Army's Future Force?			5. FUNDING NUMBERS	
6. AUTHOR(S) LTC Jeffrey D. Ingram				
7. PERFORMING ORGANIZATION NAME(S) AND ADDRESS(ES) US Army Command and General Staff College School of Advanced Military Studies 250 Gibbon Ave. Fort Leavenworth, KS 66027			8. PERFORMING ORGANIZATION REPORT NUMBER	
9. SPONSORING / MONITORING AGENCY NAME(S) AND ADDRESS(ES) U.S. Army Command and General Staff College Fort Leavenworth, KS 66027			10. SPONSORING / MONITORING AGENCY REPORT NUMBER	
11. SUPPLEMENTARY NOTES				
12a. DISTRIBUTION / AVAILABILITY STATEMENT Approved for public release; distribution is unlimited.			12b. DISTRIBUTION CODE A	
13. ABSTRACT (Maximum 200 Words) On 28 March 2003, Task Force 2-70 Armor was detached from the 3rd Infantry Division and attached to the 101st Airborne Division (Air Assault) West of Al Kifl, Iraq. The tactical relationship between the Army's Air Assault Division and a heavy Task Force was a success even though the soldiers at the Captain level and below had never worked together nor trained with the other force. The logistical relationship between the two organizations was a logistical failure because the two forces never developed a logistical structure that would have allowed the heavy Task Force to maintain and regenerate its heavy equipment and operate with the light division longer than it did. As a result of Operation Iraqi Freedom it appears that the U.S. Army can place a heavy Task Force into a Light Infantry organization during combat operations and the resultant combined arms team will be immediately effective. Throughout our Army's history we have fought together as a Heavy-Light force and have recognized that the Heavy-Light force is the correct organization in many wartime tactical situations but we have matriculated back to separate and distinct light and heavy forces in peacetime. Our Heavy and Light forces are marginally prepared to fight as a Heavy-Light Team and are unprepared to support each other logistically for extended periods of time. In many tactical scenarios the best solution is a Heavy-Light team with durable armored vehicles combined with many Infantrymen on the ground. The Army is transforming to a modular structure with three types of Brigade Combat Teams. What is not found in this future structure is a force with both heavy and light forces. Solutions to this problem are a Heavy-Light BCT or an Independent Heavy Maneuver Battalion assigned to a Light Infantry UEx. Both these organizations will provide the Army the capability of employing a fully trained Heavy-Light force capable fighting as a team as well as capable of maintaining itself logistically for extended periods of time.				
14. SUBJECT TERMS Armor, Light Infantry, Combined Arms, Urban Operations			15. NUMBER OF PAGES 44	
			16. PRICE CODE	
17. SECURITY CLASSIFICATION OF REPORT U	18. SECURITY CLASSIFICATION OF THIS PAGE U	19. SECURITY CLASSIFICATION OF ABSTRACT U	20. LIMITATION OF ABSTRACT none	

SCHOOL OF ADVANCED MILITARY STUDIES

MONOGRAPH APPROVAL

LTC Jeffrey D. Ingram

Title of Monograph: Where is the Heavy-Light Organization in the Army's Future Force?

Approved by:

Peter J. Schifferle, Ph.D.

Monograph Director

Kevin C.M. Benson, COL, AR

Director,
School of Advanced
Military Studies

Robert F. Baumann, Ph.D.

Director,
Graduate Degree
Programs

Abstract

WHERE IS THE HEAVY-LIGHT ORGANIZATION IN THE ARMY'S FUTURE FORCE? By Lieutenant Colonel Jeffrey D. Ingram, USA, 44 pages.

On 28 March 2003, Task Force 2-70 Armor was detached from the 3rd Infantry Division and attached to the 101st Airborne Division (Air Assault) West of Al Kifl, Iraq. The tactical relationship between the Army's Air Assault Division and a heavy Task Force was a success even though the soldiers at the Captain level and below had never worked together nor trained with the other force. The logistical relationship between the two organizations was a logistical failure because the two forces never developed a logistical structure that would have allowed the heavy Task Force to maintain and regenerate its heavy equipment and operate with the light division longer than it did. This problem is not unique, for none of our Army's light forces are prepared to logistically support a heavy Task Force and the training relationship between light and heavy forces is almost nonexistent especially at the Battalion and lower tactical levels.

As a result of Operation Iraqi Freedom it appears that the U.S. Army can place a heavy Task Force into a Light Infantry organization during combat operations and the resultant combined arms team will be immediately effective. Throughout our Army's history we have fought together as a Heavy-Light force and have recognized that the Heavy-Light force is the correct organization in many wartime tactical situations but we have matriculated back to separate and distinct light and heavy forces in peacetime. Our Heavy and Light forces are marginally prepared to fight as a Heavy-Light Team and are unprepared to support each other logistically for extended periods of time.

In many tactical scenarios the best solution is a Heavy-Light team with durable armored vehicles combined with many Infantrymen on the ground. This is particularly true in urban terrain and as the world's population continues to grow more and more terrain is becoming semi-urban and urban. The Army has no ready and standing organization with this structure.

The Army is transforming to a modular structure with three types of Brigade Combat Teams (BCT), Infantry, Stryker, and Heavy. What is not found in this future structure is a force with both heavy and light forces. One solution to this problem is a Heavy-Light BCT consisting of the normal Reconnaissance and Surveillance Squadron, Brigade Troops Battalion, Fires Battalion, but with an enhanced Support Battalion and a Combined Arms Battalion and Infantry Battalion. Another solution is an Independent Heavy Maneuver Battalion assigned to a Light Infantry UEx. Both these organizations will provide the Army the capability of employing a fully trained Heavy-Light force capable fighting as a team as well as capable of maintaining itself logistically for extended periods of time.

TABLE OF CONTENTS

INTRODUCTION.....	1
THE PROBLEM	4
BACKGROUND.....	7
WORLD WAR ONE THROUGH VIETNAM	11
JUST CAUSE, RESTORE HOPE, AND DESERT STORM	19
OPERATION IRAQI FREEDOM	23
COLLECTIVE AND INDIVIDUAL TRAINING.....	32
THE SOLUTION	36
CONCLUSION	42
APPENDIX	43

INTRODUCTION

A cautionary note on training and readiness is necessary. The US armed forces have often been justly accused of preparing to fight the last war. In considering how to prepare for the next war...The Army should not adopt the Iraqi model as the basis for determining the operational environment. Instead, the OIF experience can inform the design of threats and scenarios. Replicating the operational environment must be so dynamic that operating in conditions of uncertainty and ambiguity becomes second nature to soldiers and their units.¹

On Point, The United States Army in Operation Iraqi Freedom

On 28 March 2003, Task Force 2-70 Armor was detached from the 3rd Infantry Division and attached to the 101st Airborne Division (Air Assault) West of Al Kifl, Iraq. On 9 May 2003, this spectacularly successful 42-day tactical relationship between the Army's Air Assault Division and a Heavy Task Force ended as the last Brigade Combat Team (BCT), the 3rd BCT of the 101st Airborne Division (Air Assault) departed Southern Baghdad for Mosul and Task Force 2-70 Armor remained in Baghdad. The relationship between the heavy Task Force and the 101st Airborne (Air Assault) leadership (MG David Patreaus, BG Benjamin Freakley, COLs Joseph Anderson, Michael Linnington and Ben Hodges) had been professionally fulfilling from the beginning with them immediately making the Task Force feel welcome and as contributing members of the team. At the time the Task Force 2-70 Armor leaders and soldiers thought it had been a very unique relationship: tanks working in conjunction with the light infantry, integrated and fighting side-by-side at every level from an individual tank working with an infantry squad, to tank company/teams with two tank platoons and a Air Assault infantry platoon to an Air Assault Infantry company/team with two Air Assault platoons and a tank platoon, to the Task Force working with the three different BCT headquarters. However, there was nothing historically unique about this Heavy-Light relationship, for the U.S. Army has been utilizing this

¹ Gregory Fontenot, E.J. Degan, and David Tohn, *On Point, The United States Army in Operation Iraqi Freedom*. (Kansas: Combat Studies Institute Press, 2004), 385.

combined arms concept at every level since the advent of mounted warfare. The soldiers involved thought the relationship unique because they excelled at something for which they had neither prepared nor trained.

The tactical relationship between the Army's Air Assault Division and a heavy Task Force was a success even though the soldiers at the Captain level and below had never worked together nor trained with the other force. There were numerous "firsts" for every soldier involved. Riding on a tank, seeing and hearing a tank main gun fire, having to actually know where the infantry were on the ground prior to moving the tank or firing, and talking to an infantry squad leader ten feet away while in contact with the enemy were all new experiences for the soldiers in Task Force 2-70 Armor and the infantry soldiers who worked with the tanks. The tactical successes were due to the leadership involved at every level with special emphasis on the company, platoon, squad, and tank level junior officers' and Non Commissioned Officers' flexibility, innovation, and ability to quickly plan, rehearse, and execute a plan. Some of this success can be attributed to their Army training and education and the remainder must be attributed to their internal innovation, for few were more than vaguely familiar with the other and few had any training on how to integrate and fight with the other.

The logistical relationship between the Army's Air Assault Division and a heavy Task Force bordered on failure. The soldier specific logistical problems were readily solved but the heavy equipment logistical problems were not. The 101st Airborne Division (Air Assault) was not prepared to support the Task Force logistically² and the Task Force was not capable of supporting itself logistically. The Division did not know it would have a heavy Task Force attached and Task Force 2-70 Armor did not know it would be part of the Air Assault Division so neither had the opportunity to take any action to better prepare itself. The 82d Airborne Division

² U.S. Army. *Field Manual 63-2, Division Support Command, Armored, Infantry, and Mechanized Infantry Divisions*, (Headquarters, Department of the Army, 20 May 1991), C-1.

had the same issue when Task Force 1-41 Infantry (Mechanized) was attached to it. The Airborne Division was not equipped to support a heavy Task Force³ and Task Force 1-41 Infantry (Mechanized) was not capable of supporting itself logistically. Light Divisions are equipped to provide logistical support to their own organic forces while heavy Task Forces are equipped to receive support from their BCT's Forward Support Battalion and a very robust Division level and higher logistics structure.⁴ When the 101st Airborne Division (Air Assault) departed Baghdad for Mosul, the Division Commander, MG Patreaus, had no choice but to leave Task Force 2-70 Armor with its tanks and heavy equipment in Baghdad. There were no Heavy Equipment Tank Transports available and the tanks were in no condition to move under their own power from Baghdad to Mosul. Every single tank was non-mission capable due to a lack of a system to replace the damaged and worn out parts necessary to keep them operational.

The attachment of Task Force 2-70 Armor to the 101st Airborne Division (Air Assault) was a tactical success and a logistical failure. The two disparate forces quickly formed a series of combined arms teams that were unbeatable in every combat situation they faced. However, soldiers were killed and equipment was destroyed because these two dissimilar groups had not worked nor trained together in the past. The two forces never developed a logistical structure that would have allowed the heavy Task Force to maintain and regenerate its heavy equipment and operate with the light division longer than it did. This problem is not unique, for none of our Army's light forces are prepared to logistically support a heavy Task Force and the training relationship between light and heavy forces is almost nonexistent especially at the Battalion and lower tactical levels.

³ U.S. Army. *Field Manual 63-2*, C-1.

⁴ U.S. Army. *Field Manual 63-20, Forward Support Battalion*, (Headquarters, Department of the Army, 26 February 1990), E-1.

CHAPTER ONE

THE PROBLEM

The Army has a good system for collecting and then applying lessons at the tactical level and is very good about developing tactics, techniques, and procedures that may be applied in similar conditions. But there are lessons or at least implications that may reasonably be discerned from Operation Iraqi Freedom (OIF) that transcend tactics, techniques, and procedures. These broader lessons are really only learned when they are applied in training, force structure, and combat developments. This takes time and study to determine whether what works in the short term really has application over time and in other environments.⁵

On Point, The United States Army in Operation Iraqi Freedom

As a result of Operation Iraqi Freedom it appears that the U.S. Army can place a heavy Task Force into a Light Infantry organization during combat operations and the resultant combined arms team will be immediately effective. Given the successes of Task Force 2-70 Armor with the 101st Airborne Division (Air Assault), Task Force 1-41 Infantry (Mechanized) with the 82d Airborne Division, Task Force 1-63 Armor with the 173rd Airborne Brigade, and Company C, 2-70 Armor with Task Force 20 the lesson learned could be that our tactics, techniques, and procedures (TTPs), doctrine, and training methodology with regard to Heavy-Light Operations are acceptable and effective and no changes are necessary. I submit that while our TTPs and doctrine are effective, our training methodology for Heavy-Light operations and the subsequent institutional knowledge gained from that training is virtually nonexistent. This includes the tactical training at all levels as well as the sustainment and logistical training

⁵ Fontenot, 383.

required for the Infantry headquarters to develop the short term and knowledge necessary to support a heavy Task Force in any sort of tactical training or combat operations over extended periods of time. Our Heavy and Light organizations are thoroughly unfamiliar with the culture, capabilities, limitations, and support requirements of the other.

A lesson learned results in a change in behavior. Has our Army learned any lessons and changed our behavior with regard to Heavy-Light Operations since the tank was first introduced in 1918 or do we as an Army merely record data, publish TTPs and the subsequent doctrine at the end of every conflict and then revert back to that with which we are comfortable or that which is the most efficient? We have recorded lessons but not changed our behavior. Throughout our history we have fought together as a Heavy-Light force and have recognized that the Heavy-Light force is the correct organization in many wartime tactical situations but we have matriculated back to separate and distinct light and heavy forces in peacetime. With the exception of Camp Casey, Korea, light Infantry and Armor units are not currently stationed on the same post and do not fall under the same division chain of command.⁶ Our Army's transformation to a modular structure will not change this dynamic especially at the BCT level and below unless light and heavy forces end up collocated on the same installation and are willing to establish the Heavy-Light team I will recommend in the solution chapter.

The Army has published TTPs and doctrine for Heavy-Light Operations but makes insignificant and insufficient attempts to train to and on this doctrine within peacetime training constraints. The multiple Heavy-Light organizations formed for Operation Iraqi Freedom should not have had to overcome the series of tactical and logistical problems they encountered. Historically the light infantry and armor have fought together as a team in combat since the tank was first introduced in France in June of 1918. In many tactical situations this mix of light

⁶ John W. Karagosian, and Christopher M. Coglianesse, "KINGS OF THE ROAD, Heavy and Light Forces in MOUT." (Fort Benning, Georgia, *Infantry*, Volume 93, Issue 1, February 2001), 43.

infantry and heavy forces is the best solution. This best solution could continue as the locations where the U.S. Army will most likely conduct combat operations continue to develop from rural areas to semi urban and urban areas. The increased population and accelerated growth of cities have made the problems of combat in built-up areas a requirement for the Army as we can no longer avoid this type of combat.⁷ If we think we are going to fight as a Heavy-Light force and we want to be more effective and better able to sustain that force for a longer period of time without the heavy force culminating before the mission is accomplished then we need to prepare our forces now. We need to take this opportunity as the Army is transforming and remolding itself into a modular structure to establish a force with a mix of light and heavy forces, a permanent Heavy-Light capable force. I will use broad historical examples and the resultant lessons learned or lessons noted to show that even though we recognize the need to train to fight Heavy-Light we always matriculate back to separate and distinct heavy and light organizations. In the end I will propose a solution to ensure that our Heavy-Light force is well prepared to fight as a team as well as sustain itself over the long term without the heavy force culminating due to a lack of logistical support.

⁷ Center for Army Lessons Learned. Newsletter 99-16, *Urban Combat Operations*. (Fort Leavenworth, Kansas: Center for Army Lessons Learned, November 1999), 4-14.

CHAPTER TWO

BACKGROUND

Unsupported Armor is vulnerable during the close fight in cities and towns. Light infantry, while better suited for combat in urban areas, is vulnerable crossing open areas and building the combat power required to clear and secure enemy-held buildings. Historically, the most successful units in MOUT are those that utilize combined arms, with infantry platoon or company-sized formations centered on armor sections and platoons. Armor and infantry operating together mitigate each other's weaknesses and complement each other's strengths, a good example of synergy.⁸

Captains John Karagosian and Christopher Coglianese

On 28 March 2003, Task Force 2-70 Armor was detached from the 3rd Infantry Division and attached to the 101st Airborne Division (Air Assault). The Task Force was ordered to link up with the 2d Brigade of the 101st just West of the Iraqi town of Al Kifl, Iraq. As the Task Force received the orders, Company A, 2-70 Armor was immediately sent from Task Force 1-64 Armor and attached to 1st Brigade, 101st. Company C, 2-70 Armor was detached from Task Force 2-70 Armor and attached to Task Force 1-41 Infantry (Mechanized) in As Samawah and subsequently to Task Force 20 in Northwest Iraq. As the Task Force moved from the Western side of An Najaf to Al Kifl, the Task Force commander contemplated that only a miniscule part of the Task Force had ever worked with the Light Infantry.⁹ The Task Force had had a Mechanized Infantry Company, Company A, 1-41 Infantry (Mechanized), attached for the past year back at Fort Riley, but other than the size and shape of its vehicles and its ability to put

⁸ Karagosian, 40.

⁹ Personal recollection of the author. 28 March 2003, South of Al Kifl, Iraq.

eighty or so Infantryman on the ground it was essentially another heavy company. The Task Force was being attached and was going to integrate and fight with a dissimilar organization with which it was unfamiliar and for which it had never trained. Over the next 42 days Task Force 2-70 Armor remained attached to the 101st Airborne (Air Assault).

The Task Force was initially attached to the 2d BCT commanded by COL Anderson. One of the first questions he asked the Task Force commander was about how much fuel he needed. The reply, “about forty-five thousand gallons a day,” brought the conversation to an abrupt halt.¹⁰ The 400 gallon fuel trailer parked in the background could have been a hysterically funny joke if the impending fuel shortage was not so serious. The Task Force 2-70 Headquarters and Headquarters Company Commander, CPT Jason Hatch knew where all the V Corps and 3ID fuel farms were so fuel was never an issue for the Task Force. Had fuel become an issue the 101st leaders and logisticians would have taken whatever action was necessary and diverted whatever assets were necessary from the remainder of the Division to ensure the heavy Task Force remained mobile and able to fight. However; the 101st was not prepared to assume the logistical responsibilities for the heavy Task Force. This is true of the 82d Airborne Division and its attached heavy force, Task Force 1-41 Infantry (Mechanized), as well as Task Force 1-63 Armor with the 173rd Airborne Brigade and Company C, 2-70 Armor with Task Force 20. While the short term logistical shortfall of fuel resupply was readily solved, the long term shortfall, spare parts to keep the heavy equipment operational, was never solved. The long term tactical advantages of integrating heavy forces with the light infantry, under the light infantry support structure was almost nullified because of logistics shortcomings.

A good example of the tactical unfamiliarity between the light and heavy forces is the differences in scale in which they are accustomed to thinking and planning. Task Force 2-

¹⁰ Personal recollection of the author. 28 March 2003, Al Kifl, Iraq.

70 Armor led the 3rd BCT's 8 April 2003 attack on Al Hillah and Babylon. Task Force 2-70 Armor's mission was to clear the route through Al Hillah and then secure various objectives in Babylon. As part of the route clearance a tank company was left securing two key intersections and a bridge in Al Hillah to be quickly relieved by the follow on Battalion. Twenty minutes after crossing the Line of Departure, the Task Force, minus the tank company guarding intersections, exited Al Hillah and began to clear objectives in Babylon. Forty minutes after crossing the Line of Departure the tank company commander in Al Hillah inquired if the follow on forces had run into difficulties because they had not yet relieved his platoon closest to the Line of Departure. A call to the follow on force commander revealed that the follow on Battalion wasn't planning on beginning its movement for another hour and twenty minutes.¹¹ The light force was thinking at dismounted movement speeds while the heavy force was thinking at mounted movement speeds. The light force was moving dismounted and its analysis showed that the heavy mounted force wouldn't be clear of the Line of Departure for another hour and the first intersection for another hour and twenty minutes. The heavy force commander thought the light force would be right behind him and that his company guarding the intersections would be relieved within minutes and then be available to seize objectives in Babylon. Neither force was familiar with the thoughts, limitations, and capabilities of the other. Had the two dissimilar forces worked and trained closely together in the past and trained as a team this situation would not have occurred.

There is a large difference in the scales in which the heavy and light forces think, plan and execute tactical and logistical operations. Time, space, distance, speed, size, and weight all have different meanings to a heavy and light force. These differences are exacerbated when the two forces are thoroughly unfamiliar with each other but can be mitigated by close cooperation and training. By conducting consistent Heavy-Light training the two dissimilar

¹¹ Personal recollection of the author. 8 April 2003, Babil, Iraq.

forces can develop into a cohesive team that can plan and execute short and long term tactical and logistical operations in any situation.

CHAPTER THREE

WORLD WAR ONE THROUGH VIETNAM

Infantry and tank teams began fighting together in a Heavy-Light configuration when the American Expeditionary Forces entered combat in France in June of 1918. The term configuration is more appropriate than the term team as the two distinct forces never had the opportunity to develop into a team since all the tanks belonged to a separate Tank Corps and were allocated to the different infantry Corps by the Army Headquarters in response to the tactical situation. Tank units were pushed to a subordinate infantry Division and its subordinate Regiments for an operation then returned to the Tank “pool” when the operation was completed. The Infantry units rarely had the same tank unit allocated to them and this resulted in a lack of coordination between the infantry and tank unit commanders, a lack of understanding each other’s strength and weaknesses and failure to develop a standard operating procedure (SOP) as a Heavy-Light team. The benefits of a habitual relationship had not yet been realized at the higher levels as the tank brigade commanders pushed unfamiliar tank battalions down to each of the divisions. This could have been prevented if a tank battalion or company had been organic to the division and its infantry regiments allowing them to develop SOPs and cohesion.¹²

The lesson learned from World War One was that tanks and infantry working together as a Heavy-Light team were sometimes the best tactical solution and were lethal and effective. The lesson that was merely noted was that the two distinct forces need to develop a habitual relationship and understanding of each others’ capabilities, limitations, and thought

¹² Richard R. Rouleau, MAJ, “Have Gun, Will Travel: A Tank Company in the Light Infantry Brigade.” (Fort Leavenworth, Kansas 2003), 31.

processes that would result in TTPs, doctrine, and SOPs. The units that train together are more effective.

Heavy-Light operations in World War Two II demonstrated the same inability to develop consistent Heavy-Light teams as had occurred in World War One. Due to limited tank assets, the general headquarters and corps level maintained independent tank battalions and allocated them down to divisions as needed. Routinely, the division pushed these assets down to the infantry regiment level in company-sized units to support regimental missions. The tank companies could find themselves in various mission sets, working for infantry battalions of the regiments or as regimental reserves. However, due to a lack of independent tank battalions assigned to the theater, the infantry divisions and their subordinate commanders never developed TTPs as combined arms teams with the tank companies. The regimental combat team commander rarely had the same tank battalion or company team working for him. Essentially, the regimental commander could not develop the same cohesive relationship that he had with his own battalions, and his soldiers did not perform as well learning new and different techniques every time they linked up with tanks. Toward the end of the war, it was apparent to some commanders that units that stayed together and trained together executed their missions as a cohesive team. Upon the completion of World War II, the Army conducted a series of studies and several General Officer Theater Review Boards with various infantry and armor division commanders, infantry regiment commanders, and independent tank battalion commanders. These boards and studies reviewed every aspect of combat operations and support. One of the recommendations was that the Army assign a tank battalion to each infantry division and separate tank companies to each of the division's infantry regiments. This recommendation resulted in the formation of the Regimental Tank Company.¹³

¹³ Rouleau, 41.

LTC(R) Bogardus S. Cairns shares an example of Heavy-Light operation preparation and execution in his 1949 *Military Review* Article, “The Breakout at Anzio, A lesson in Tank-Infantry Cooperation.”

“Tank units underwent platoon, company and battalion exercises working with the infantry units with which it was expected they would operate in the coming offensive. The minutest details of tank-infantry cooperation were worked out. Telephones were installed on the rear of tanks to permit the infantryman on the ground to communicate with the tank commander so as to give him instructions or to point out targets that were holding up the infantry. Tank platoon leaders and company commanders installed SCR 300 radios on their tank turrets to insure radio communication with their supporting infantry. Arrangements were made to carry extra small-arms ammunition and mortar ammunition on the back decks of the tanks to make the infantryman’s burden lighter and to insure an adequate resupply of ammunition once the attack jumped off. Smoke and pyrotechnic signals were arranged to permit the infantryman to make his wishes known to the tankers. All these details and others were put into practice in the training exercises until all personnel in the units were thoroughly familiar with them. [Once the attack started] The attack waves of medium tanks, leading the way through the gaps....were followed by waves of infantry from the 135th Infantry, closely supported by light tanks. The mission of the light tanks was to assist the infantry moving forward by destroying enemy machine guns or strong points that were missed by the leading waves of medium tanks. It was here that all the preparations and joint training of the infantry and tanks paid large dividends. The tanks and infantry worked together so well that by mid-afternoon Combat Command A had captured its initial objective along the railroad and by dark had pushed 500 yards beyond....Here again the

teamwork developed between the tanks, infantry, and engineers in the training prior to the jump-off paid dividends.¹⁴

One can imagine attempting to conduct combat operations with a dissimilar organization without the opportunity to conduct detailed rehearsals.

The lessons learned from Heavy-Light operations in World War Two are consistent with those learned and noted in World War One. Tanks and infantry working together as a Heavy-Light team were sometimes the best tactical solution and were lethal and effective. The two distinct forces need to develop a habitual relationship and understanding of each others' capabilities, limitations, and thought processes that would result in TTPs, doctrine, and SOPs. The difference is that the World War Two lessons were learned and the result was the development of the Regimental Tank Company. The Army assigned a tank battalion to each infantry division with its subordinate tank companies assigned to each of that division's infantry regiments.¹⁵

This Regimental Tank Company was added to the infantry division's organization prior to the start of the Korean War. Unfortunately these Regimental Tank Companies were assigned to the divisions only on paper due to an Army post World War II theater-wide reallocation and reorganization of forces.¹⁶ At the beginning of the Korean War the four infantry divisions assigned to the Far East Command had only one of the tank companies on hand with which to fill the new authorization so the initial combat operations in Korea were fought without tanks. Eventually, the tank battalions arrived and were assigned to the various Infantry Divisions. The 70th Heavy Tank Battalion was assigned to the First Cavalry Division

¹⁴ Bogardus S. Cairns, LTC(R). "The Breakout at Anzio, A Lesson in Tank-Infantry Cooperation." (Fort Leavenworth, Kansas, *Military Review*, January 1949), 23-32.

¹⁵ Rouleau, 3.

¹⁶ Rouleau, 3.

with Company A attached to the 5th Cavalry Regiment, Company B to the 8th Cavalry Regiment, and Company C to the 7th Cavalry Regiment.¹⁷ The 6th Heavy Tank Battalion was attached to the 24th Infantry Division, the 73rd to the 7th Infantry Division, the 72nd Tank Battalion to the 2nd Infantry Division and the 64th Tank to the 3rd Infantry Division. These heavy tank battalions had much of their logistics structure internally organic and were logistically a part of the division to which they were assigned.

In his book *Strike Swiftly, Korea, 1950-1953, 70th Heavy Tank Battalion*, Ed Daily shares an example of a Heavy-Light force that was thrown together at the last minute.

“At approximately 1545 hours, the Armored Task Force began to move.

As the column reached the vicinity of Koksu-ri, enemy mortar and machine gun fire began to rake the column. The infantry immediately dismounted and returned the fire. Without planned artillery support, the Task Force was to be successful only if it continued to move. COL Crombez ordered the tank commanders to advance, but they apparently forgot to signal the infantry prior to movement because the tanks moved without the infantry. Fortunately, most got back on the tanks, although over thirty infantrymen, including two officers, were left behind. After clearing Kiksui-ri, the column was halted by a heavy volume of fire. Once more the infantry dismounted and deployed. Immediately, both infantry and tanks became engaged. Suddenly, the tank, without warning the infantry, started to move out. After the second halt, there were less than seventy men from company L left on the tanks. During the next three and a half miles the column was forced to halt several more times, and after each halt, a few more infantrymen were inadvertently left behind.”¹⁸

¹⁷ Edward L. Daily, *Strike Swiftly Korea, 1950-1953, 70th Heavy Tank Battalion*, (Paducah, Kentucky, Turner Publishing Company, 2000), 103-104.

¹⁸ Daily, 103-104.

In the beginning of the Korean War the infantry and tank teams struggled because the leadership had forgotten the lessons learned from World War II. The Regimental Tank Companies were still passed from infantry unit to infantry unit but they developed the institutional knowledge that allowed them to integrate with the infantry better than before. After three years of fighting with their respective regiments, the success of these teams validated doctrine and reaffirmed the decisions made after World War II assigning Regimental Tank Companies to the divisions.¹⁹

The Regimental Tank Team proved its effectiveness and lethality during the Korean War. Unfortunately the lesson was not learned since with few exceptions the concept of assigning the tank battalions to the Infantry Divisions was cancelled after the Armistice was signed and the majority of the U.S. forces redeployed to the United States and United States Army Europe. The Army matriculated back to separate and distinct heavy and light forces.

Combat in Vietnam once again found tank units conducting combat operations in direct support of dismounted infantry. Initially, as plans were developed and units were assigned for the mission to Vietnam, the Department of the Army and the commander of forces in Vietnam decided not to deploy tank battalions, believing that tanks could not operate in Vietnam's jungle environment. This belief changed when the 173rd Airborne Brigade deployed to Vietnam as one of the first combat elements. The brigade deployed from Japan with its separate tank company, Company D, 16th Armor, equipped with M113 armored personnel carriers and M56 antitank systems, and the brigade's light cavalry troop, Troop E, 17th Cavalry.²⁰ With the success of Company D, 16th Armor, in combat operations, the Army deployed three other divisional tank battalions to Vietnam in support of their respective divisions and brigades. Once in Vietnam, the

¹⁹ Rouleau, 4.

²⁰ Rouleau, 50.

tank companies of the deployed tank battalions formed a solid habitual working relationship with their respective infantry brigades, executed infantry and tank team operations throughout Vietnam. The TTPs developed for tanks in support of dismounted infantry stayed consistent until the end of the war. At the end of the Vietnam War, the 173rd was deactivated along with its separate tank company. This left the Army with only one light infantry division, the 82nd Airborne Division with an organic tank battalion.²¹ The U.S. Marine Corps used the Heavy-Light organization in the battle of Hue in 1968. The enemy resistance was so strong that the infantry could not do it alone. The Marine Corps combined the efforts of infantry and tanks to accomplish their goal and clear the city.²²

The lessons learned from Heavy-Light operations in Vietnam are consistent with those learned and noted in World War One, World War Two, and Korea. Tanks and infantry working together as a Heavy-Light team were sometimes the best tactical solution and were lethal and effective. The two distinct forces need to develop a habitual relationship and understanding of each others' capabilities, limitations, and thought processes that would result in TTPs, doctrine, and SOPs. Unfortunately, with the exception of the 82nd Airborne Division and its organic Tank Battalion, 3rd Battalion 73rd Armor, the Army discontinued the relationship and matriculated back to distinct and separate heavy and light forces with mechanized infantry forces somewhere in the middle.

The heavy forces and light forces have worked together through out the history of mounted warfare. In many tactical scenarios the best solution is a Heavy-Light force with multiple capabilities. World Wars One and Two, Korea, and Vietnam offer numerous examples of the integration of heavy and light forces fighting side by side reinforcing and complementing each other.

²¹ Rouleau, 1.

²² Center for Army Lessons Learned. *Urban Combat Operations*, 4-14.

JUST CAUSE, RESTORE HOPE, AND DESERT STORM

As for tanks, I love them. They are an infantryman's friend in city fighting. They can go anywhere. They can deliver steel on target and they scare the enemy. I cannot say enough about the performance of the Sheridan tanks that supported us. (When is the light infantry going to get some tanks of its own?) Of course, we had to provide infantry security for them and had to work hard on communications. One of the scariest moments for me in the entire operation was when I had to cross an area that had received sniper fire and climb into a tank because I didn't have radio communication with the tank commander.²³

MAJ Robert G. Boyko, Operations Officer of 1st Battalion, 9th Infantry Regiment.

The 82d Airborne Division deployed to Panama and Operation Just Cause with part of its organic tank battalion, the 3rd Battalion, 73rd Armor Regiment. The soldiers of the division were thoroughly familiar with the Sheridans as they trained with them periodically and conversely the Sheridan crews were thoroughly familiar with the light infantry because they worked with them everyday.²⁴

The former Operations Officer of 3rd Battalion, 73rd Armor stated, "We KNEW HOW THE 82ND AIRBORNE FOUGHT. We had been an integral part of every field exercise, MOUT operation (before any one was talking about Armor in built-up areas), and every air drop mission for years. Each platoon was habitually associated with an Airborne Infantry Company which allowed us to develop, refine and practice our SOPs and TTPs. The infantry knew how to mount the vehicle, where to dismount and move to when under small arms fire or mortar attack, how to scan sectors and even became proficient in replacing track. In turn the, tankers learned how to stop the vehicle

²³ Robert G. Boyko, MAJ. "Just Cause MOUT Lessons Learned," (Fort Benning, Georgia, *Infantry*, May-June, 1991), 28-32.

²⁴ Frank Sherman, MAJ. "Operation Just Cause: The Armor-Infantry Team in the Close Fight," (Fort Knox, Kentucky, *Armor*, September-October, 1996), 33-35.

without throwing the infantry to the ground, where the infantry would move once dismounted and how to provide cover as the infantry cleared buildings and trenches without fratricide. In Panama this teamwork was essential when we moved into the slums of Panama City. The Infantry protected our flanks and we reciprocated by providing direct fire where ever they needed it. We communicated via the external telephone which the infantry knew how to operate and enjoyed a "breather" surrounded by armor. We understood how the infantry would talk us on to a target, "Blue Building, 1000 o'clock, 75 meters, West wall, second floor, Right, third window; was a typical threat identification. The infantry also understood our weapons systems and sought cover when we announced, "Preparing to fire - ON THE WAY".²⁵

The 1st Battalion 9th Infantry received an attachment of Sheridan tanks during Operation Just Cause and the Battalion S-3 stated "We always began our offensive sweeps with a display of powerful force. The venerable Sheridan tanks of the 82nd Airborne Division that accompanied us had a tremendous psychological effect."²⁶

The lesson learned from Operation Just Cause was that an integrated force of Light Infantry and Armor is very effective especially when the two forces have worked closely together in the past and have developed a habitual relationship. This Heavy-Light team, the 82nd Airborne Division with its organic Armor Battalion was lethal and effective. The 3rd Battalion, 73rd Armor units that were task organized to 1st Battalion, 9th Infantry of the 7th Infantry Division were effective because those tankers had worked and trained with the light infantry and understood how the light infantry operated.

²⁵ Frank Sherman, LTC. 6 February 2005 Interview with the author.

²⁶ Boyko, 30.

An example of a situation when heavy forces could have averted a disaster is the U.S. Army Ranger raid on the Olympic Hotel to capture top Somali warlord Aideed's Lieutenants on October Third 1993 in Mogadishu, Somalia. The U.S. forces were surrounded and in the ensuing fire-fight suffered eighteen soldiers killed in action and eighty-four wounded in action. Once the Rangers were pinned down the relief columns mounted in HUMMWVS and trucks took an unexpectedly long time to get to the Olympic Hotel because of roadblocks and ambushes that severely hampered the movement of the relief convoys but would have been only marginally effective against U.S. tanks and Bradley Fighting Vehicles. The Rangers on the ground were armed with the latest weapons, and the technology in the command chopper flying above the battle resembled something out of the Pentagon war room, however the Somalis had their own way of communicating, albeit quite primitive. To alert other Somalis that a battle was taking place, they burned tires where the Americans were now trapped. Thousands of Somalis, all of them is seemed, armed with AK-47s, poured into the downtown area. They might not have been good soldiers, they might have been poorly trained and inclined to duck down and hold their weapons up to fire away. But some of them were brave, there were a lot of them, and the AK-47 is one of the best infantry weapons of the modern age.²⁷ The trapped forces were eventually extracted by elements of the 10th Mountain Division using borrowed tanks and armored personnel carriers. The lack of prior coordination by the Rangers was a calculated risk taken to maintain operational security. The addition of armor might have allowed for quicker reaction and possibly fewer casualties.²⁸

The situation on the ground required some heavy forces and the ground force had requested that heavy force. Unfortunately the request was disapproved by the Secretary of

²⁷ David Halberstam, *War in a Time of Peace, BUSH, CLINTON, and the Generals*. (New York: A Touchstone Book, Simon and Schuster, 2001), 261-262.

²⁸ Center for Army Lessons Learned. *Urban Combat Operations*, 4-13.

Defense in order to clarify the Administration's policy and limit the vulnerability of the mission.²⁹ The situation warranted Armor support. Armor support was requested and denied and the result was a tragedy.

The 82nd Airborne Division deployed to Saudi Arabia in the very beginning of Operation Desert Shield and established defensive positions in Northern Saudi Arabia. It deployed with its organic tank battalion, 3rd Battalion, 73rd Armor Regiment, an integral part of the division and emplaced it across the defense as a mobile anti-tank force.³⁰ This was a problem-free operation with no unusual integration pains because the Sheridans of the 3-73 were always part of the Airborne Division. The lesson learned here is that the integration of the Heavy-Light force was so ingrained in the Division that no notice was taken of it. In short it was business as usual and that business was operating smoothly and giving the Airborne Division a level of ground lethality unmatched by any other light infantry division in the U.S. Army.

²⁹ Halberstam, 261-262.

³⁰ Robert H. Scales Jr., BG, Director, Desert Storm Study Group, *United States Army in the Gulf War, Certain Victory*. (Washington DC, United States Army, Office of the Chief of Staff, 1993), 49-51.

OPERATION IRAQI FREEDOM

Heavy-Light operations sound great in a classroom but are virtually useless unless company commanders train together and understand each other's capabilities. An understanding of heavy/light operations should not remain at higher levels of command, but should be common knowledge to the leaders who are actually on the ground. A properly task organized unit that can work in synchronization is a powerful force that can overcome any obstacle on today's battlefield. Heavy-Light operations are the future of our profession. Company commanders who have a clear understanding of how to integrate the two infantry forces will succeed on the future battlefield, where they will be able to move fast, strike hard, and seize the day. This works well when the two have previously established a working relationship and understand each other's strengths, weaknesses, and SOPs.³¹

Keith A. McKinley, *Working with the Light Fighters*

There are many instances where Heavy-Light organizations operated very effectively in Operation Iraqi Freedom. Examples include Task Force 2-70 Armor with the 101st Airborne Division (Air Assault), Task Force 1-41 Infantry (Mechanized) with the 82d Airborne Division, Task Force 1-63 Armor with the 173rd Airborne Brigade, and Company C, 2-70 Armor with Task Force 20. These organizations were tactical successes and long term logistical failures. The two disparate forces quickly formed a series of combined arms teams that were unbeatable in

³¹ Keith A. McKinley, Working With the "Light Fighters," Tips for Mechanized Company Commanders, (Fort Benning, Georgia, *Infantry*, Volume 91, Issue 2, May 1, 2002): 40.

every combat situation they faced. However, soldiers were killed and equipment was destroyed because these two dissimilar groups had not worked nor trained together in the past. The two forces never developed a logistical structure that would have allowed the heavy Task Forces to maintain and regenerate its heavy equipment and operate with the light division longer than it did. This problem is not unique, for none of our Army's light forces are prepared to logistically support a heavy Task Force and the training relationship between light and heavy forces is almost nonexistent especially at the Battalion and lower tactical levels.

Our Heavy and Light organizations are unfamiliar with the culture, capabilities, limitations, and support requirements of the other, especially at the Battalion level and below. There were many tactical situations for which TF 2-70 Armor was unprepared and untrained. During the course of the 2nd Brigade Combat Team and Task Force 2-70 Armor feint towards Al Hillah on 31 March 2003, eight AH-64s were passed/pushed to the Task Force. The Task Force Executive Officer did a fantastic job of receiving the aircraft via FM, querying them for their ordnance and available time on station and handing them off to the Task Force Commander forward with the lead company. All eight of the aircraft were shot and hit by enemy fire and had to depart station early. While the Task Force commander thinks it would be great personally to place the blame on the pilots, he thinks that if only one or two had been shot he could, however the blame rests solely on him and his inability to verbalize what he wanted the aircraft to do and where he wanted them to go.³² Neither the Task Force commander, his operations officer, nor any of the organic Heavy company/team commanders had ever talked to or controlled attack helicopters in this type of scenario in training. The Task Force training was limited to simulations at the Brigade and Division level where the Brigade sometimes had an attack aviation company involved or incorporated and controlled at the brigade level with an over the shoulder

³² Personal recollection of the author. 31 March 2003, South of Al Hillah, Iraq.

type mission that had been planned, briefed, and rehearsed prior to its execution in the simulation. The expectation of the 101st leadership was that the Task Force commander and the remainder of the Task Force leadership knew how to direct and control the aircraft; since it is common for aircraft control to be passed from the Brigade Combat Team to the Task Force to the Company Team to the platoon in the Light Infantry organizations, however; the Task Force commander initially failed. In the 6 April 2003 attack on Karbala and 8 April 2003 attack on Al Hillah, and 13 and 14 April 2003 attack from Babylon to Baghdad the Task Force had continuous rotary wing aircraft coverage. By that time it had learned how to talk to them and had developed the skills to get the aircraft to do what the Task Force wanted them to do. Had the Task Force been an integral part of the 101st Airborne (Air Assault) it would have been trained on and familiar with this skill.

The light infantry moves by walking or coordinating for helicopters or trucks. The Task Force 2-70 Armor organic forces were permanently mounted so the Task Force commander did not have to coordinate with any outside source, he just gave the word and the Task Force moved. When the Task Force linked up with COL Anderson and the 2nd BCT at Al Kifl he immediately attached Company C, 1-502nd Infantry (Air Assault), to the Task Force. The Task Force commander cross attached a tank platoon to that company, which was guarding a bridge over the Euphrates, to give them some additional firepower and a more robust night thermal capability and the next morning cross attached an Air Assault platoon to Company B, 2-70 Armor to give that company an Infantry capability. As the Task Force prepared for the next morning's fight towards Al Hillah it dawned on the company and Task Force commanders that there was no way the cross attached Infantry platoon could move itself from the Line of Departure the 15 to 20 kilometers to the Limit of Advance. Given the speed of the tanks and distance involved there was no option but to put the Infantry on the tanks, a technique that no one involved had ever done before. They were familiar with the Fort Knox Pamphlet that detailed how to mount the infantry on the tanks although it did not account for the space nullified by the

addition of the anti fratricide panels mounted on the sides and back of the tank turret. The company commander was uncomfortable with the concept since no one involved had ever done it before and the Infantry would be sitting exposed on the sides and back of the tanks.³³ They identified a probable line of contact and the Task Force Commander told the company commander to dismount the infantry short of that line. That line was about one hundred meters to far to the North and at 0430 on 31 March 2003 a soldier from Company C, 1-502nd Infantry (Air Assault), was killed as he rode into combat on the back of the company commanders M1A1 tank.³⁴ If the Task Force had trained with the Light Infantry in the past and been more in tune with what was a threat to them versus what was a threat to us the Task Force and the company commander would have been more skilled at knowing when to dismount the Light Infantry from the tanks.

Since the Task Force always had a Light Infantry Company attached it had to figure out a way to move them around the battlefield. After suffering its first casualties the Task Force commander was not inclined to move them around on the tanks.³⁵ The Headquarters and Headquarters Company (HHC) commander cross leveled the loads on the HHC and line company five-ton trucks and sent forward seven trucks, each with a driver and soldier to man the fifty Caliber machine gun on the ring mount. See Appendix, Photo 1. The Task Force was now self sufficient with regards to transportation. It developed and executed a technique where the light infantry trailed the last heavy company by one to two kilometers, generally staying in a secure location until needed. Whenever the Task Force encountered a situation where it needed the Infantry capability it trucked them right in behind the heavy company securing and overwatching the area and dismounted them. Initially the Task Force commander did not realize that walking a

³³ D. Bradley Laauwe conversation with the author on 30 March 2003 in Baghdad, Iraq.

³⁴ Personal recollection of the author. 31 March 2003, South of Al Hillah, Iraq.

³⁵ Personal recollection of the author. 31 March 2003, South of Al Hillah, Iraq.

few kilometers would wear an infantryman out. He had just never thought about it because in his world everything is mounted³⁶ whereas in the light infantry world it is a long walk. The Task Force implemented this employment technique so the infantrymen were delivered to the fight as physically rested as possible and it proved to be very successful.

There are large difference in scale between the Heavy Forces and the Light Infantry. In the feint toward Al Hillah on 31 March 2003 the Task Force outran its Artillery Support thirty minutes after it crossed the Line of Departure and endured an hour of having only its four organic one hundred and twenty millimeter mortar platoon available for indirect fires. The Task Force was used to the Paladin moving and traveling along with it but in this case it had the towed one hundred and five millimeter howitzers of the 101st Airborne (Air Assault) Artillery in direct support. The Task Force commander did not realize that the howitzers would have to be stowed and re-attached to their prime movers, then moved, then unhooked, then placed back into the firing configuration. The Artillery Battalion Commander knew the limitations of his howitzers but didn't think about the pace of the Armor operation. He was still thinking in Light Infantry speeds and the Task Force 2-70 commander was thinking in mounted speeds. In the next attack on Al Hillah where he was in Direct Support, both were both much more familiar with the others' capabilities and limitations. Task Force 2-70 took the Air Assault Artillery movements into account as it developed its plan and the Artillery Battalion commander placed two batteries right along the Line of Departure and leapfrogged the third forward as soon as the Task Force started moving. Through their interaction they developed into a team and were much more effective and lethal.

On 6 April 2003 Task Force 2-70 Armor attacked to seize and clear a zone on the Northeast portion of Karbala. The Task Force consisted of a tank company, a tank team and an

³⁶ Personal recollection of the author.

Air Assault Infantry Company. The heavy companies led and attacked to seize key buildings and intersections while the Air Assault Infantry Company trailed and then cleared a large objective consisting of a city block with many government buildings and Ba'ath Party Headquarters. The tanks rapidly seized their objectives and shortly thereafter the Air Assault Infantry began clearing its objective. It seemed to the Task Force commander that the Infantry were moving at a snails pace and as the day progressed he became more and more agitated waiting for them to report that their objective was clear and secure. At about fifteen hundred hours he got very upset when the Air Assault Infantry company commander reported the objective was clear and secure and that the company was going to go to ground for an hour to rest and rehydrate.³⁷ The Task Force commander had identified many more point targets that he wanted the Infantry to clear and he, of course, wanted them cleared now rather than later. The Task Force commander linked up with the company commander and a ten-second visual inspection of the company showed him why they needed an hour to rehydrate and rest. They were worn out. The Task Force commander had traveled about one hundred kilometers in the past five hours checking out every aspect of his zone, though he was hot and dusty he had ridden one hundred kilometers, standing comfortably in his turret. The Air Assault Infantry had probably traveled two and a half kilometers in the same time, however, they had been running, walking, and crawling that distance as they cleared their objective. Once again the Task Force commander had been thinking as a rider rather than as a walker, and a walker wearing body armor and carrying a basic load of ammunition and water at that.

The 101st Airborne Division (Air Assault) used its attached Heavy Task Force very effectively. In An Najaf, the division started its adaption to the enemy at hand. It learned from the 3rd Infantry Division and subsequently from its own attacks in An Najaf, Al Kifl, and Al

³⁷ Personal recollection of the author. 6 April 2003, Karbala, Iraq.

Hillah. At Al Kifl, the soldiers validated what they learned here – they “allowed the tanks to react to the initial small-arms fire [and then maneuvered] the infantry against the enemy once contact was made.”³⁸ Eventually, the division fought in eight different cities, noting that each required slightly different approaches based on the terrain and prevailing conditions. But the essential lesson of these urban fights was that integrating combined arms, heavy and light forces, armored raids, and a liberal application of precision airpower applied in each case. Their tactics evolved for subsequent operations in Baghdad and elsewhere.³⁹

In an interview with Patrecia Hollis of *The Field Artillery Journal* LTG Wallace the Commanding General of V Corps stated, “Another pleasant surprise was the success armored formations had operating in urban environments. Fundamentally, we used heavy metal to “bust” into the cities and take down whatever defenses the Iraqis had. Then we used light formations to clear the cities and towns in detail, supported by smaller groups of armored vehicles. That freed up larger armored formations to go break down other “doors.” Armored vehicles were effective in urban environments frequently without dismounted infantry to protect them.”⁴⁰

The 173rd Airborne Brigade’s combat capability also improved with the deployment of the United States Army Europe Immediate Ready Force. The Immediate Ready Force is a C-17-transportable unit that includes a heavy ready company, or five Abrams tanks and four Bradley Infantry Fighting Vehicles, and M113-based medium ready company, organic fire support, and elements of a forward support battalion.⁴¹ Task Force 1-63 Armor of the 1st Infantry Division, commanded by Lieutenant Colonel Ken Riddle, served as the Immediate

³⁸ 101st Airborne Division After-Action Report. 30 April 2003.

³⁹ Fontenot, 273.

⁴⁰ Hollis, Patrecia Slayden, Editor, *Trained, Adaptable, Flexible Forces = Victory in Iraq* INTERVIEW - Lieutenant General W. Scott Wallace CG of V Corps in Iraq during OIF, (Fort Sill, Oklahoma, *Field Artillery Journal*, Volume 8, Issue 5, October 2003), 9-13.

⁴¹ Patrick Warren, LTC and Keith Barclay, MAJ. “Operation Airborne Dragon, Northern Iraq,” (Fort Leavenworth, Kansas, *Military Review*, November-December 2003), 11-14.

Ready Force when the war began. The first elements of Task Force 1-63 Armor began deploying from Rhein Ordnance Barracks in Kaiserslautern, Germany, on the evening of 7 April 2003.⁴²

Company C, 2-70 Armor arrived at Tallil Air Base early in 2 April 2003 to link up with Special Operations personnel and transported ten M1A1 tanks, three M113 armored personnel carriers, a FST-V fire-support vehicle, two fuel trucks, three cargo trucks, and a HMMWV by C-17 aircraft to H-1 airfield in Western Iraq. One of the key planning considerations for the operation was the tanks' fuel consumption since a single tank used as much fuel in a day as an entire Ranger company in Ground Mobility Vehicles. Air Force transports moved Captain Celeen's company in 15 sorties over three days.⁴³ On arrival at H-1 airfield, the company came under the control of the 1st Battalion, 75th Ranger Regiment. The rangers and the tank company road-marched one hundred and sixty kilometers East, back towards Baghdad, and began conducting raids in the Bayji-Tikrit area. In addition to the raids, the tank company supported interdiction missions along Highway 1 to Syria, attempting to seal the border from fleeing Ba'athist and Iraqi military personnel. The company supported Joint Special Operations Task Force-West from the second to the twenty-fourth of April, until the 4th Infantry Division assumed responsibility for the area. This rapid intra-theater movement and multiple task reorganizations integrating conventional and Special Operations Force units demonstrate the power of joint integration to meet the ever-changing tactical and operational situation in the theater.⁴⁴

What is clear from Operation Iraqi Freedom is that combined arms and tailoring or task-organizing to create combined arms worked in Operation Iraqi Freedom. Combining the

⁴² Fontenot, 225.

⁴³ Robert W. Jones, Jr. "Team Tank: Armor in Support of Special Operations," (Fort Bragg, North Carolina, *Journal of Army Special Operations History, Veritas, Operation Iraqi Freedom*, Winter 2005), 71.

⁴⁴ Fontenot, 253-254.

battlefield effects of engineers, maneuver units, and fires clearly produced synergy. The Army proved able to task-organize on the move to create combined arms teams tailored to mission requirements and could do so on little or no notice. This stemmed from training, education, doctrine, and practice that produced a culture which supported flexible organizations on the basis of the analysis of the mission, enemy, terrain, and weather, troops and support available, time available, and the proximity of civilians or critical infrastructure that might affect execution.⁴⁵

⁴⁵ Fontenot, 398.

COLLECTIVE AND INDIVIDUAL TRAINING

Combined arms operations are the bedrock of heavy maneuver force tactics. But if a maneuver unit commander is to maintain the tactical proficiency of a company team or a battalion task force, he needs to have both the infantry and armor components consistently available for training. Unfortunately, this is not easily attained. Even within brigades, training priorities, budget limitations, scheduling conflicts, or competing activities often keep task forces from forming for specific training periods. As a consequence, infantrymen and tankers seldom gain the practical experience they need to employ attached combat elements effectively. Leaders, therefore, have to exploit any procedure that brings them closer to attaining this fundamental training objective. One technique that has proved successful in solving this training problem is the extended cross-attachment of maneuver companies between infantry and tank battalions in the same brigade.⁴⁶

LTC William A DePalo JR. *Extended Cross-Attachment*

We train the way we fight because our historical experiences show the direct correlation between realistic training and success on the battlefield.⁴⁷ The Army's current training methodology does not adequately prepare the heavy force to work with the light force and conversely, the light force to work with the heavy force, particularly at the battalion level and below. Each focuses on its own internal proficiency. In any given year the Army conducts 2

⁴⁶ William A. DePalo Jr. LTC. "Extended Cross-Attachment,," (Fort Benning, Georgia, *Infantry*, July-August 1984), 5-6.

⁴⁷ U.S. Army. *Field Manual 7-0, Training the Force*, (Headquarters, Department of the Army, October 2002), 1-1.

mixed (light-heavy or heavy-light) rotations at each of the Combat Training Centers; the Combat Maneuver Training Center in Hohenfels, Germany; the Joint Readiness Training Center at Fort Polk, Louisiana; and the National Training center at Fort Irwin, California. These rotations attach a light infantry battalion to a heavy brigade combat team or a heavy team to a light infantry brigade combat team for the rotation. While these rotations look great on paper and expose the senior leadership of the units to the planning and execution considerations of the other they accomplish very little at the battalion and company level. During a rotation only a small fraction of the company commanders and the soldiers in their companies are exposed to the other. These rotations are not enough for even familiarization let alone proficiency at any level. Brigade Combat Teams and Task Forces consist of units who meet for the first time in the initial planning phases, a mere three to six months prior to the rotation. They usually have few established SOPs. Worse, they will have no opportunity to really work on anything until the rotation. The tendency is toward centralization, with the heavy team fighting as a separate formation and infantry battalions fighting without armor support.⁴⁸

The 3rd BCT of the 101st Airborne Division (Air Assault) conducted a Joint Readiness Training Center rotation with a company team from 2nd Battalion, 34th Armor Regiment in 2002. During the course of this Heavy-Light rotation two Infantry soldiers from the 3rd BCT were killed, run over by tanks during an attack on the Shugart-Gordon MOUT facility. The tanks were supporting an Infantry unit preparing to assault the facility and began receiving indirect fire.⁴⁹ As a defensive measure against indirect fire armor crewmembers are trained to immediately close their hatches and move out of the area. The Infantry soldiers are trained to immediately seek cover and concealment. When they received the artillery fires the Infantrymen immediately dove for the ground and the armor crewmembers in their tanks immediately closed

⁴⁸ Karagosian, 43.

⁴⁹ Michael Linnington. Conversation with the author in April 2003 in Baghdad, Iraq.

their hatches and drove away. The Observer Controllers had employed many safety constraints, were interspersed with the units training, and were even riding on the lead tank in order to protect the safety of the participants and achieve the training objectives.⁵⁰ However, as the artillery began to impact all the soldiers involved instinctively reacted as they had been trained. Seven months after that unfortunate accident the soldiers of the 3rd BCT were fighting side by side with the tanks of Task Force 2-70 Armor in Al Hillah, Babylon, and Baghdad, Iraq. The solution to this ensure an accident such as this never occurs again is not to conduct less Heavy-Light training in the future, the solution it is to conduct much more in the future so each understands exactly what the other is going to do no matter what the situation. The two must train together until they are a team with common understanding of the others capabilities, limitations, reactions, and thought processes.

The curriculums of the basic training and advanced individual training at both the Home of Armor at Fort Knox, Kentucky and the Home of the Infantry at Fort Benning, Georgia show no scheduled training on the other. The training is focused on turning civilians into soldiers and on teaching them the basics skills to be an Infantryman⁵¹ or Armor crewmember.⁵² Attendance at the Non Commissioned Officer Education System courses^{53,54}, officer basic courses, and Captains' career course exposes the students to the other arm through interaction with other students and some instruction and training on combined arms operations. The

⁵⁰ George Brinegar. Conversation with the author on at Fort Riley, Kansas.

⁵¹ U.S. Army Infantry Homepage. *Infantry Training Brigade, Infantry One Station Unit Training Cycle Template*, (Fort Benning, Georgia), <http://www.infantry.army.mil/itb>.

⁵² U.S. Army Armor School and University of Mounted Warfare. *1st Armor Training Brigade, 19D and 19K One Station Unit Training*, (Fort Knox, Kentucky), <http://www.knox.army.mil/school/1atb/index.htm>.

⁵³ U.S. Army Infantry Homepage. *Fort Benning's Noncommissioned Officer Academy*, (Fort Benning, Georgia), <http://www.benning.army.mil/ncoa/main/.htm>.

⁵⁴ U.S. Army Noncommissioned Officers Academy. *Advanced Noncommissioned Officer Course, Basic Noncommissioned Officer Course, Primary Leadership Development Course*, (Fort Knox, Kentucky), <http://www.us.army.mil/suite/portal/index.jsp>.

Mechanized Infantrymen are best trained to conduct Heavy-Light operations as they are trained on both dismounted operations as well as mechanized infantry operations.

THE SOLUTION

As we prepare for the future, we must think differently and develop the kinds of forces and capabilities that can adapt quickly to new challenges and to unexpected circumstances. We must transform not only the capabilities at our disposal but also the way we think, the way we train, the way we exercise and the way we fight. We must transform not only our armed forces, but also the Department that serves them by encouraging a culture of creativity and prudent risk-taking. We must promote an entrepreneurial approach to developing military capabilities, one that encourages people to be proactive, not reactive, and anticipates threats before they emerge.⁵⁵

Honorable Donald H. Rumsfeld, Secretary of Defense

The Army is changing now and the changes ahead are significant—the most comprehensive transformation of the U.S. Army since World War Two. A continuous cycle of innovation, experimentation, experience and change will lead to a campaign-quality Army with joint and expeditionary capabilities. This army will provide dominant land power to the Joint Force now and into the future. The decisive effort of Army transformation is the creation of modular, combined arms maneuver brigade combat team (unit of action), or BCT, of which there are three types: Heavy (armored/mechanized), Stryker, and Infantry.⁵⁶ As part of this transformation, the Army migrates capabilities that were previously found at divisions and corps to the BCT – the building block of combat forces in the future Force. Each type of BCT will be of standard configuration and will gain improved force packaging, sustainability, battle command, and situational awareness while retaining the same lethality as the larger, task-organized brigade combat teams. These units will serve as the foundation for a land force that is balanced and postured for rapid deployment and sustained operations worldwide. Army general-purpose modular formations will be capable of rapidly foreclosing an adversary's options,

⁵⁵ Donald H. Rumsfeld, *Defense Planning Guidance*, (Washington D.C., Department of Defense, 2003), 1.

⁵⁶ Karl Lowel, "A Proposal for the Future Army, Reshaping America's Army," (Army Magazine, March 2005), 58.

achieving decisive results in major combat operations, and setting many of the security conditions for enduring conflict resolution.⁵⁷

As the Defense Department moves on transformation, the operational environment remains dynamic and so must the transformation effort. Equally important, friends, adversaries, and even some who are neither will seek ways to cope with perceived U.S. strengths and exploit perceived U.S. weaknesses.⁵⁸ While this transformation adapts to the current and projected operational environment it does not adapt to the current and projected tactical environment and does not adequately address the very basic tenet of Army tactical training that we “train the way we fight.”⁵⁹ The inadequacy of the transformation is that it does not improve the interoperability between the light infantry and armored forces. Throughout our Army’s history, since the introduction of the tank on the battlefield in France in World War One, light Infantry and Armored forces have fought as part of a Heavy-Light team. Given the increased urbanization of the world it is prudent to be prepared to fight in urban terrain, in terrain that requires numerous infantrymen on the ground reinforced with a heavy armor capability. In terrain that requires a Heavy-Light organization like those that have been so successful throughout our history. What one does not find is a BCT comprised of a heavy battalion and a light infantry battalion or a heavy maneuver battalion habitually associated with an infantry UEx. After the Army’s modularization is complete the infantrymen in an Infantry BCT will still not have had the opportunity to work with his mounted heavy partner prior to engaging in combat operations. Conversely, the Armor and Mechanized Infantry crewmen in a Heavy BCT will not have had the opportunity to work with his dismounted partner on the ground prior to engaging in combat operations. The Army has proven that it can successfully attach a Heavy Task Force to an Air

⁵⁷ *United States Army 2004 Army Transformation Roadmap*, (Washington D.C., Department of the Army, 2004),

⁵⁸ Fontenot, 387.

⁵⁹ U.S, Army, *Field Manual 7-0*, 1-1.

Assault Division “on the fly” and conduct combat operations very effectively; however, it can be better prepared, more lethal and effective in the future. This Heavy-Light team can be achieved by establishing a BCT with both a heavy maneuver battalion and an infantry battalion or a heavy maneuver battalion habitually associated with an Infantry UEx.

One solution is to establish a Heavy-Light BCT with the specific mission to form and train Heavy-Light Teams and be the Army’s Heavy-Light experts. This BCT would be immediately lethal and effective in any type of combat operations especially in an urban environment where many infantrymen reinforced by heavy armor forces are the best tactical solution. The BCT logistics structure would be able to sustain both its light and heavy forces much better than a normal infantry BCT for it would have the organic capability to conduct the required support. The equipment of the heavy force would not slowly decay during combat operations due to a lack of logistics infrastructure. There would be teams of Infantry and Tanks that had trained, worked and practiced together, that had developed a habitual relationship and had developed and tested SOPS and TTPs for working together. If this BCT were to be split into its separate heavy and light components, it could provide a heavy maneuver battalion trained and ready to integrate and fight with the light infantry forces and a light infantry battalion trained and ready to integrate and fight with a heavy force. Two forces that understand the capabilities, limitations, and culture of the other. The wiring diagram of this proposed Heavy-Light BCT is shown in Figure 1. The Table of Organization and Equipment for the Reconnaissance Squadron, Infantry Battalion, and Heavy Maneuver Battalion would remain the same as they are planned and programmed to be in the Army’s Transformation Plan. The Brigade Troops Battalion and Support Battalion would need to be a composite between the Infantry BCT and Heavy BCT to compensate for the capabilities and limitations of two types of forces within the BCT.

Another solution to achieve a trained and prepared Heavy-Light force is to establish an Independent Heavy Maneuver Battalion with an Infantry UEx and that UEx’s associated Infantry BCTs. This would be the corollary to the Independent Tank Battalions

assigned to each of the Infantry Divisions during the Korean War. This battalion must have the capabilities to operate in a pure formation and operate as a task force with various heavy companies detached and light infantry companies attached. This will require a moderately upgraded command and control capability as well as an upgraded logistics capability within the battalion and within the UEx to which it is assigned. The proposed wiring diagram of the independent heavy maneuver battalion is shown in figure 2.

The Forward Support Company (FSC) in the maneuver battalion's structure is organic to the Heavy BCT's Brigade Support Battalion (BSB) and is habitually in Direct Support to the Maneuver Battalion. In order to allow the Maneuver Battalion to operate independently of the normal support structure in a Heavy BCT there are several additions to the FSC table of organization and equipment structure that will be necessary. They are an increase in transportation assets to haul bulk Class III and package products, Class V, and Class IV; an upgraded Direct Support maintenance capability and an upgraded communications structure. The transportation and maintenance capabilities must be able to perform those functions available in the BSB in the Heavy BCT but not available in the light infantry BCT. While these assets can be placed in any of the BSBs or Logistics Brigade in the UEx structure placing them in the heavy Battalion FSC contributes to the flexibility and deployability of the heavy TF in the light infantry UEx.

The companies within this battalion must be able to operate under the control of their organic headquarters as well as under the control of a light infantry BCT headquarters or light infantry battalion headquarters. This will require a moderately enhanced command and control capability as well as an enhanced maintenance capability. The subordinate tank and mechanized infantry teams will also require some additional assets in order to be able to operate independently of the Heavy Battalion Headquarters should the UEx commander attach only a company to a Light Infantry Battalion. The proposed wiring diagram of one of the companies within the Independent heavy maneuver battalion is shown in Figure 3. Additions include a

command and control vehicle with crew and additional direct support maintenance assets in order to give the company a communications capability similar to a Regimental Cavalry Troop.

The advantages of a trained and ready Heavy-Light team are many when compared to a Heavy organization attached to a Light organization “on the fly” and committed to the battlefield. The numerous “firsts” that every soldier involved in the Heavy-Light team experienced, riding on a tank, seeing and hearing a tank main gun fire, having to actually know where the infantry were on the ground prior to moving the tank or firing, and talking to an infantry squad leader ten feet away while in contact with the enemy would not have to be experienced for the first time in combat, but could be experienced and learned during peacetime training. Both the Heavy and Light soldiers would be much more familiar with every aspect of the other and would have the opportunity, training, and experience to form cohesive Heavy-Light teams. The organization would be equipped to support both a Heavy and a Light force with the ability to maintain and regenerate its heavy equipment. The leaders and soldiers involved would thoroughly know and understand the TTPs, doctrine and culture of Heavy-Light operations. The Heavy-Light organization would actually understand and implement the lessons learned from past wars that would result in a change in behavior, a Heavy-Light team prepared to fight together as a team.

One can say that the Stryker BCT can fulfill this Heavy-Light capability. While this solution is feasible but it is not the best solution. The numbers of infantrymen the Stryker BCT can put on the ground might be adequate, in no way is the Stryker vehicle or any of its variants as immune to enemy fire as the M1 tank. The principle argument against employing wheeled vehicles, especially in an urban environment is that they are more vulnerable than tracked

vehicles.⁶⁰ Another feasible solution is to attach a light infantry battalion to a heavy BCT commanded by an Infantry Colonel and push parts of that light infantry battalion down to the maneuver battalion commanded by an Infantry Lieutenant Colonel. While this solution is feasible the soldiers at the company level and below will still need the training time to develop into a team, to develop the TTPs, SOPs, and familiarity with each other.

One can also propose that we could cross attach a Maneuver Battalion from a Heavy Brigade Combat Team to the Infantry BCT to fulfill this Heavy-Light capability as was done during Operation Iraqi Freedom. The Army recognized that within a BCT various maneuver companies are habitually cross-attached between the Armor Battalion and the Mechanized Infantry Battalion and as a result we have changed the MTOE of our battalions to have them consist of two tank companies and two mechanized infantry companies. However it will not alleviate the problem of heavy forces and light forces working together at the Task Force, Company/Team, platoon and individual level. While attaching heavy and light forces “on the fly” has proven to be successful, it is not the best solution with regards to establishing a working relationship, to establish a team. This can only be done by physically placing heavy forces within the light infantry structure permanently.

⁶⁰ Richard M. Ogorkiewicz, “Armor and Future Urban Warfare,” (Fort Knox, Kentucky, *Armor*, Volume 113, Issue 2, April 2004), 4.

CHAPTER EIGHT

CONCLUSION

The Army has proven that it can combine heavy and light forces together for combat operations “on the fly,” and have the resulting organization be an immediate tactical success, effective and lethal on the battlefield. This compilation of dissimilar forces is a short term tactical success but a long term logistical failure. Heavy and light forces have been fighting together as a Heavy-Light team in combat since the tank was first introduced on the battlefield in World War One. However during peacetime the heavy and light forces have matriculated back into separate and distinct forces with separate and distinct cultures. This peacetime separation that ignores the lessons learned from previous Heavy-Light combat operations results in the relearning or rediscovery of those lessons when the two diverse forces are combined for combat operations. While it appears that the newly established Heavy-Light team is immediately effective, that team could be much more effective if the team members had the opportunity to establish the team, to apply doctrine, establish TTPs, SOPs, and a familiarity with one another in the peacetime training environment. The light organizations are not capable of supporting heavy forces logistically and the heavy forces are not capable of supporting themselves when separated from their Forward Support Battalions and robust Division level and higher logistics structure.

One solution to this problem is a Heavy-Light BCT consisting of the normal Reconnaissance and Surveillance Squadron, Brigade Troops Battalion, Fires Battalion, but with an enhanced Support Battalion and a Combined Arms Battalion and Infantry Battalion. Another solution is an Independent Heavy Maneuver Battalion assigned to a Light Infantry UEx. Both these organizations will provide the Army the capability of employing a fully trained Heavy-Light force capable fighting as a team as well as capable of maintaining itself logistically for extended periods of time.

APPENDIX

FIGURE 1: THE PROPOSED HEAVY-LIGHT BRIGADE COMBAT TEAM WIRING DIAGRAM

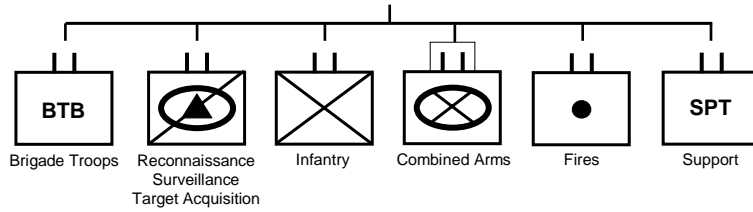

FIGURE 2: THE INDEPENDENT HEAVY MANEUVER BATTALION WIRING DIAGRAM

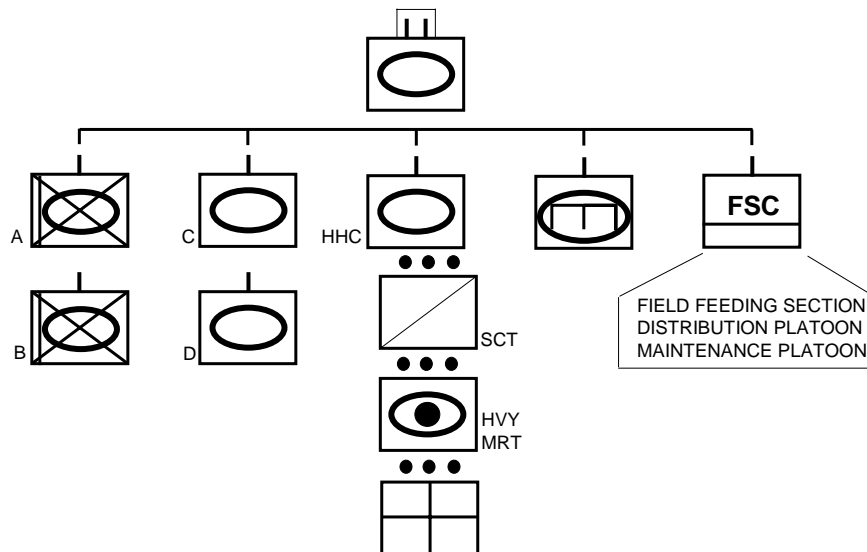

FIGURE 3: THE HEAVY MANEUVER COMPANY WIRING DIAGRAM

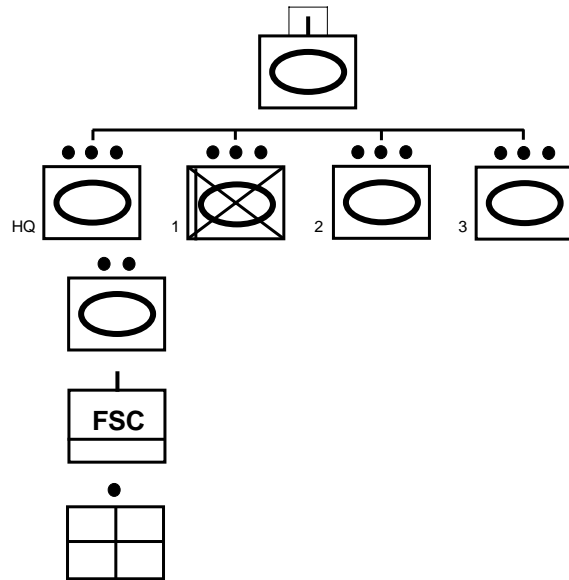

PHOTO 1: AIR ASSAULT INFANTRY MOUNTED IN TRUCK



BIBLIOGRAPHY

- Adams, John A. "Balancing Strategic Mobility and Tactical Capability," Fort Leavenworth, Kansas, *Military Review*, (August 1988): 9-23.
- Atkinson, Rick. *In the Company of Soldiers*. New York: Henry Holt and Company, 2004.
- Boyko, Robert G. MAJ. "Just Cause MOUT Lessons Learned," Fort Benning, Georgia, *Infantry*, (May-June 1991): 28-32.
- Blumenson, Martin. "Hwachon Dam-Korea, 1951, The 4th Ranger Company and the 7th Cavalry in Action," Fort Benning, Georgia, *Infantry*, (May-June 1996): 20-30.
- Bonin, John A. and Crisco, Telford E. Jr. "The Modular Army," Fort Leavenworth, Kansas, *Military Review*, (March-April 2004): 21-27.
- Boyko, Robert G. MAJ. "Just Cause MOUT Lessons Learned," Fort Benning, Georgia, *Infantry*, (May-June 1991): 28-32.
- Bridges, Frank, CPT and Evans, Michael R. CPT(P). "Tough Bows and Iron Blades: Modifying the M1 for Urban Battle," Fort Knox, Kentucky, *Armor*, Volume 112, Issue 4, (August 2003): 11-17.
- Brinegar, George, COL. Former Commander of 2nd Battalion, 34th Armor. Conversation with author. November 2002, Fort Riley, Kansas.
- Cairns, Bogardus S. LTC(R). "The Breakout at Anzio, A Lesson in Tank-Infantry Cooperation," Fort Leavenworth, Kansas, *Military Review*, (January 1949): 23-32.
- Center for Army Lessons Learned. Newsletter 90-9, *Operation Just Cause Lessons Learned. Vol. II, Operations*. Fort Leavenworth, Kansas: Center for Army Lessons Learned, 1990.
- Center for Army Lessons Learned. Newsletter 90-3, "*The Stone Forrest, Lessons Learned. a Heavy/Light Combat Narrative*". Fort Leavenworth, Kansas: Center for Army Lessons Learned, May 1990.
- Center for Army Lessons Learned. Newsletter 98-10, *Fighting Light/Heavy in a Restricted Terrain*. Fort Leavenworth, Kansas: Center for Army Lessons Learned, April 1998.
- Center for Army Lessons Learned. Newsletter 99-16, *Urban Combat Operations*. Fort Leavenworth, Kansas: Center for Army Lessons Learned, November 1999.
- Crowell, Howard G. MG and Bates, Jared L. LTC. "Heavy-Light Connection: Division," Fort Benning, Georgia, *Infantry*, (July-August 1984): 15-18.
- Daddis, Gregory A. MAJ. "Understanding Fear's Effect on Unit Effectiveness," Fort Leavenworth, Kansas, *Military Review*, (July-August 2004): 22-27.
- DeSario, George Jr. CSM. "Task Force Modularity/Force Stabilization," Fort Knox, Kentucky, *Armor*, (SEP-OCT 2004): 5.
- Daily, Edward L. *Strike Swiftly Korea, 1950-1953, 70th Heavy Tank Battalion*. Paducah, Kentucky, Turner Publishing Company, 2000.
- DePalo, William A. JR. LTC. Extended Cross-Attachment, Fort Benning, Georgia, *Infantry*, (July-August 1984): 5-6.

- Downing, Wayne A. BG. "Light Infantry Integration in Central Europe," Fort Leavenworth, Kansas, *Military Review*, (September 1986): 19-29.
- Durante, Arthur A. and Eno, Russell A. "TF 1-15: An Infantry Task Force Goes to War," Fort Benning, Georgia, *Infantry*, Volume 92, Issue 2, (January 2004): 21-36.
- Fastabend, David A. and Simpson, Robert H. "Adapt or Die" the Imperative for a Culture of Innovation in the United States Army,
- Fontenot, Gregory, Degan, E.J. and Tohn, David. *On Point The United States Army in Operation Iraqi Freedom*. Kansas: Combat Studies Institute Press, 2004.
- Foster, Chad, CPT. "Preparing for Iraq, A New Approach to Combined Arms Training," Fort Knox, Kentucky, *Armor*, Volume 92, Issue 6, (December 2003): 6-9.
- Galvin, John R. LTG. "Heavy-Light Forces and the NATO Mission," Fort Benning, Georgia, *Infantry*, (July-August 1984): 10-14.
- Haig, Sir Douglas, Field Marshall. *Features of the War*. Washington D.C.: Government Printing Office, 1919.
- Halberstam, David. *War in a Time of Peace, BUSH, CLINTON, and the Generals*. New York: A Touchstone Book, Simon and Schuster, 2001.
- Hawkins, William R. "Iraq: Heavy Forces and Decisive Warfare," Carlisle, Pennsylvania, *Parameters*, Volume 33, Issue 3, (September 22, 2003): 61-67.
- Hollis, Patrecia Slayden, Editor, "Trained, Adaptable, Flexible Forces = Victory in Iraq," INTERVIEW - Lieutenant General W. Scott Wallace CG of V Corps in Iraq during OIF, Fort Sill, Oklahoma, *Field Artillery Journal*, Volume 8, Issue 5. (October 2003): 9-13.
- Kanter, Noah. "Employing Armor in Low Intensity Conflicts: Some Lessons for the Armor Force," Fort Knox, Kentucky, *Armor*, (January-February 2002): 6-14.
- Karagosian, John W. CPT, and Coglianesi, Christopher M. CPT. "KINGS OF THE ROAD Heavy and Light Forces in MOUT," Fort Benning, Georgia, *Infantry*, Volume 93, Issue 1, (February 2004): 40-54.
- Kelly, Jack. "Army Off Its Wheels," Washington D.C., *Washington Times*, (September 2, 2004): 20.
- Krepinevich, Andrew F. Jr. "The Army and Land Warfare, Transforming the Legions," Fort McNair, Washington D.C., *Joint Force Quarterly*, Issue 32, (September 22, 2002): 76-82.
- Lowe, Karl. "A Proposal for the Future Army, Reshaping America's Army," Washington D.C., *Army Magazine*, (March 2005): 53-58.
- Jones, Robert W., Jr. "Team Tank: Armor in Support of Special Operations," Fort Bragg, North Carolina, *Journal of Army Special Operations History, Veritas, Operation Iraqi Freedom*, (Winter 2005): 69-72.
- Laauwe, Donald B. CPT. Former Commander of Company B, 70th Armor Regiment. Interview by author. 2 February 2005, Fort Leavenworth, Kansas.
- Lind, William S. "Understanding Fourth Generation War," Fort Leavenworth, Kansas, *Military Review*, (September-October 2004): 12-16.
- Linnington, Michael, COL. Former Commander of the 3rd BCT, 101st Airborne Division (Air Assault). Conversation with author. April 2003, Baghdad, Iraq.

- Lyons, Terrence, and Samatar, Ahmed I. *Somalia: State Collapse, Multilateral Intervention, and Strategies for Political Reconstruction*. Washington D.C., Brookings Occasional Papers, The Brookings Institution, 1995
- Maddox, Brian, MAJ. "Checkmate on the Northern Front, The Deployment of Task Force 1-63 Armor In Support of Operation Iraqi Freedom," Fort Knox, Kentucky, *Armor*, Volume 112, Issue 5, (October 2002): 6-10.
- McCrea, Derek, 1SG. "Preparing a Mechanized Infantry Task Force for Combat, AN NCO's PERSPECTIVE," Fort Benning, Georgia, *Infantry*, Volume 93, Issue 2, (April 2004): 18-36.
- Mckinley, Keith A. "Working With the "Light Fighters," Tips for Mechanized Company Commanders," Fort Benning, Georgia, *Infantry*, Volume 91, Issue 2, (May 1, 2002): 38-40.
- McMichael, Scott R. MAJ. *A Historical Perspective on Light Infantry*. Fort Leavenworth, Kansas, Combat Studies Institute, Research Survey Number 6. September 1987.
- Mixon, MG. Modularity Overview, Fort Benning, Georgia, Infantry Conference. 20 September 2004.
- Miles, John L. III, CPT and Shankle, Mark E. CPT. "Bradleys in the City," Fort Benning, Georgia, *Infantry*, (May-June 1996): 6-7.
- Nails, John B. CPT. "A Company Commander's Thoughts on Iraq," Fort Knox, Kentucky, *Armor*, Volume 113, Issue 1, (February 2004): 13-16.
- Ogorkiewicz, Richard M. "Armor and Future Urban Warfare," Fort Knox, Kentucky, *Armor*, Volume 113, Issue 2, (April 2004): 22-25.
- O'Nan, Stewart. Editor. *The Vietnam Reader*. New York: New York, 1998.
- Reynolds, Robert A. MAJ. *Where is the Beef in the Objective Force?* Fort Leavenworth, Kansas, School of Advanced Military Studies, US Army Command and General Staff College, First Term Academic Year 2002-2003.
- Rouleau, Richard R. MAJ. "ARMOR and MECHANIZED Infantry Operations in Restrictive Terrain at JRTC," Fort Benning, Georgia, *Infantry*, Volume 92, Issue 1, (September 22, 2003): 43-48.
- _____. "Have Gun will Travel: A Tank Company in the Light Infantry," Fort Leavenworth, Kansas, US Army Command and General Staff College, 2003.
- Rouleau, Richard R. MAJ. and Pope, Carl A. 1SG. "A Technique for Preparing the M1 Series Tank for MOUT Operations," Fort Knox, Kentucky, *Armor*, Volume 111, Issue 5, (October 2002): 48-50.
- Rouleau, Richard R. MAJ. Wyatt, Wesley, SFC, and Barcinas, Martino, SFC. "Armor and Mechanized Infantry in Built-Up Areas!" Fort Knox, Kentucky, *Armor*, Volume 111, Issue 5, (October 2002): 45-47.
- Rumsfeld, Donald H. *Transformation Planning Guidance*. Washington DC, Department of Defense, 2003.
- Scales, Robert H., Jr., BG, Director, Desert Storm Study Group, *United States Army in the Gulf War, Certain Victory*. Washington DC, United States Army, Office of the Chief of Staff, 1993.

- Spiller, Roger J. General Editor, *Combined Arms in Battle Since 1939*. Kansas: Army Command and General Staff College Press, 1992.
- Showalter, Dennis, Editor. "Tank Warfare in World War II. History in Dispute, Volume 4: World War II, 1939-1943. St. James Press, 2000. Reproduced in History Resource Center. Farmington Hills, MI: Gale Group.
- Sherman, Frank, MAJ. "Operation Just Cause: The Armor-Infantry Team in the Close Fight," Fort Knox, Kentucky, *Armor*, (September-October 1996): 34-35.
- Sherman, Frank, LTC. Former Operations Officer of 3rd Battalion 73rd Armor. Interview by author. 6 February 2005, Fort Riley, Kansas.
- Stewart, Donald, CPT. McCarthy, Brian, CPT. and Mullin, James, CPT. "Task Force Death Dealers: Dismounted Combat Tankers," Fort Knox, Kentucky, *Armor*, Volume 113, Issue 1, (February 2004): 9-12.
- Swain, Richard M. *Lucky War Third Army in Desert Storm*. Kansas. U.S Army Command and General Staff College Press, 1997.
- Sullivan, Mike, CPT. "Arming the Knight for Dismounted Combat," Fort Knox, Kentucky, *Armor*, Volume 113, Issue 3, (June 2004): 7-10.
- Twohig, John J., COL. TF Modularity, Modular Army Overview, Fort Monroe, Virginia., 5 April 2004.
- Tiron, Roxanna. "Army Future Force, Abrams Tank Still Far From Retirement," Washington DC, *National Defense*, (October 2004): 40-44.
- U.S. Army. 2003. Field Manual 6-0, *Mission Command: Command and Control of Army Forces*. Washington, D.C.: Headquarters, Department of the Army, August.
- U.S. Army. 2002. *Field Manual 7-0, Training the Force*. Washington, D.C.: Headquarters, Department of the Army, October.
- U.S. Army. 2001. *Field Manual 3-90, Tactics*. Washington, D.C.: Headquarters, Department of the Army, July.
- U.S. Army. 2001. *Field Manual 3-0, Operations*. Washington, D.C.: Headquarters, Department of the Army, June.
- U.S. Army. 1995. *Field Manual 100-16, Army Operational Support*. Washington, D.C.: Headquarters, Department of the Army, May.
- U.S. Army. 1991. *Field Manual 63-2, Division Support Command, Armored, Infantry, and Mechanized Infantry Divisions*. Washington, D.C.: Headquarters, Department of the Army, May.
- U.S. Army. 1990. *Field Manual 63-20, Forward Support Battalion*. Washington, D.C.: Headquarters, Department of the Army, February.
- U.S. Army Armor School and University of Mounted Warfare. *1st Armor Training Brigade, 19D One Station Unit Training*. Fort Knox, Kentucky, <http://www.knox.army.mil/school/1atb/index.htm>.
- U.S. Army Armor School and University of Mounted Warfare. *1st Armor Training Brigade, 19K One Station Unit Training*. Fort Knox, Kentucky, <http://www.knox.army.mil/school/1atb/index.htm>.

- U.S. Army Armor School and University of Mounted Warfare. *16th Cavalry Regiment*. Fort Knox, Kentucky, <http://www.knox.army.mil/school/16cav>
- U.S. Army Infantry Homepage. *Basic Combat Training Brigade Training Overview*. Fort Benning, Georgia, http://www.infantry.army.mil/bctb/content/tng_overview.htm.
- U.S. Army Infantry Homepage. *Combined Arms and Tactics Directorate, Infantry School Officer Education System*. Fort Benning, Georgia, http://www.infantry.army.mil/catd/infantry_oes/index.htm.
- U.S. Army Infantry Homepage. *Fort Benning's Noncommissioned Officer Academy*. Fort Benning, Georgia, <http://www.benning.army.mil/ncoa/main/.htm>.
- U.S. Army Infantry Homepage. *Fort Benning's Noncommissioned Officer Academy. Advanced Noncommissioned Officer Course*. Fort Benning, Georgia, <http://www.benning.army.mil/ncoa/ancoc/course/.pdf>.
- U.S. Army Infantry Homepage. *Fort Benning's Noncommissioned Officer Academy. Basic Noncommissioned Officer Course*. Fort Benning, Georgia, <http://www.benning.army.mil/ncoa/bnoc/phase1/.pdf>.
- U.S. Army Infantry Homepage. *Fort Benning's Noncommissioned Officer Academy. Basic Noncommissioned Officer Course*. Fort Benning, Georgia, <http://www.benning.army.mil/ncoa/bnoc/phase2/.pdf>.
- U.S. Army Infantry Homepage. *Fort Benning's Noncommissioned Officer Academy. Primary Leadership Development Course*. Fort Benning, Georgia, <http://www.benning.army.mil/ncoa/pldc/guide/.pdf>.
- U.S. Army Infantry Homepage. *Infantry Training Brigade, Infantry One Station Unit Training Cycle Template*. Fort Benning, Georgia, <http://www.infantry.army.mil/itb>.
- U.S. Army Noncommissioned Officers Academy, Fort Knox Kentucky. *Advanced Noncommissioned Officer Course*. Fort Knox, Kentucky, <http://www.us.army.mil/suite/portal/index.jsp>.
- U.S. Army Noncommissioned Officers Academy, Fort Knox Kentucky. *Basic Noncommissioned Officer Course*. Fort Knox, Kentucky, <http://www.us.army.mil/suite/portal/index.jsp>.
- U.S. Army Noncommissioned Officers Academy, Fort Knox Kentucky. *Primary Leadership Development Course*. Fort Knox, Kentucky, <http://www.us.army.mil/suite/portal/index.jsp>.
- Warren, Patrick, LTC and Barclay, Keith, MAJ. "Operation Airborne Dragon, Northern Iraq," Fort Leavenworth, Kansas, *Military Review*, (November-December 2003): 11-14.
- Wickline, Jarrod P. CPT. "Integrating Dismounts into Reconnaissance and Security Operations in the Heavy Cavalry Troop," Fort Knox, Kentucky, *Armor*, Volume 113, Issue 2, (April 2004): 34-36.
- Wood, Jack B., LTC. "Heavy-Light Connection: Brigade," Fort Benning, Georgia, *Infantry*, (July-August 1984): 19-22.