

Ionic Liquids R&D- US Air Force Research Laboratory



Molecular Dynamics Contractors Meeting

24 May 2005

Monterey CA

Distribution Statement A: Public Release, Distribution unlimited.

Report Documentation Page

*Form Approved
OMB No. 0704-0188*

Public reporting burden for the collection of information is estimated to average 1 hour per response, including the time for reviewing instructions, searching existing data sources, gathering and maintaining the data needed, and completing and reviewing the collection of information. Send comments regarding this burden estimate or any other aspect of this collection of information, including suggestions for reducing this burden, to Washington Headquarters Services, Directorate for Information Operations and Reports, 1215 Jefferson Davis Highway, Suite 1204, Arlington VA 22202-4302. Respondents should be aware that notwithstanding any other provision of law, no person shall be subject to a penalty for failing to comply with a collection of information if it does not display a currently valid OMB control number.

1. REPORT DATE APR 2005		2. REPORT TYPE		3. DATES COVERED -	
4. TITLE AND SUBTITLE Research and Development of Ionic Liquids at U.S. Air Force Research Laboratory Ionic Liquids R&D - US Air Force Research Laboratory				5a. CONTRACT NUMBER	
				5b. GRANT NUMBER	
				5c. PROGRAM ELEMENT NUMBER	
6. AUTHOR(S) T Hawkins				5d. PROJECT NUMBER 5026	
				5e. TASK NUMBER 0541	
				5f. WORK UNIT NUMBER	
7. PERFORMING ORGANIZATION NAME(S) AND ADDRESS(ES) Air Force Research Laboratory (AFMC), AFRL/PRSP, 10 E. Saturn Blvd., Edwards AFB, CA, 93524-7680				8. PERFORMING ORGANIZATION REPORT NUMBER	
9. SPONSORING/MONITORING AGENCY NAME(S) AND ADDRESS(ES)				10. SPONSOR/MONITOR'S ACRONYM(S)	
				11. SPONSOR/MONITOR'S REPORT NUMBER(S)	
12. DISTRIBUTION/AVAILABILITY STATEMENT Approved for public release; distribution unlimited					
13. SUPPLEMENTARY NOTES					
14. ABSTRACT N/A					
15. SUBJECT TERMS					
16. SECURITY CLASSIFICATION OF:			17. LIMITATION OF ABSTRACT	18. NUMBER OF PAGES 13	19a. NAME OF RESPONSIBLE PERSON
a. REPORT unclassified	b. ABSTRACT unclassified	c. THIS PAGE unclassified			



AFRL Ionic Liquids Team



Those involved in this work



Stefan Schneider
Synthesis and
Characterization



Angelo Alfano
Ignition
Characterization

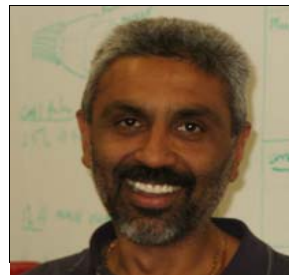

Gammy Vaghjiani
X-ray
crystallography



Jeff Mills
Theoretical
Calculations



Leslie Hall
Synthesis &
x-ray work



Donald Tzeng
Synthesis and
Characterization



Jerry Boatz
Theoretical
Calculations



Tom Hawkins
Team Lead-Propellant
Development



Why ILs as Energetic Materials?



“Tuning” IL structure for:
Energy content
Oxygen balance
Melting point
Liquid range



Propulsion:
Thrusters



Explosives:
Melt-cast munitions

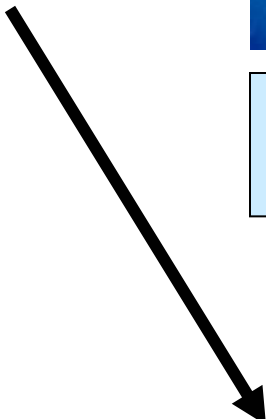

?????
Power generators,
APUs,....



AFRL Ionic Liquids



Why Ionic Liquids for Propulsion?

- A figure of merit (FOM) can be based on the momentum imparted by a HEDM normalized by that of a standard material (e.g., NTO/MMH)
- Two main properties
 - 1) Average kinetic energy (KE) of gases produced per unit mass of HEDM combusted/decomposed
 - 2) Density (ρ) of material

$$\text{FOM} = \left[\frac{(2KE_{\text{HEDM}})^{1/2} \ln(1 + c' \rho_{\text{HEDM}})}{(2KE_{\text{STAND}})^{1/2} \ln(1 + c' \rho_{\text{STAND}})} \right]$$

(where, c' = Material volume/Mass of combustor; and set to 1.0 m³/kg)

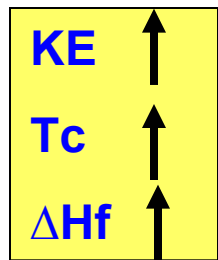

	NTO-HEHN	NTO-HEATN	NTO-MMH
KE (MJ/kg)	3.9	4.0	4.7
ρ (kg/m ³)	1424	1454	1189
FOM (STAND=NTO/MMH)	1.03	1.05	1.0

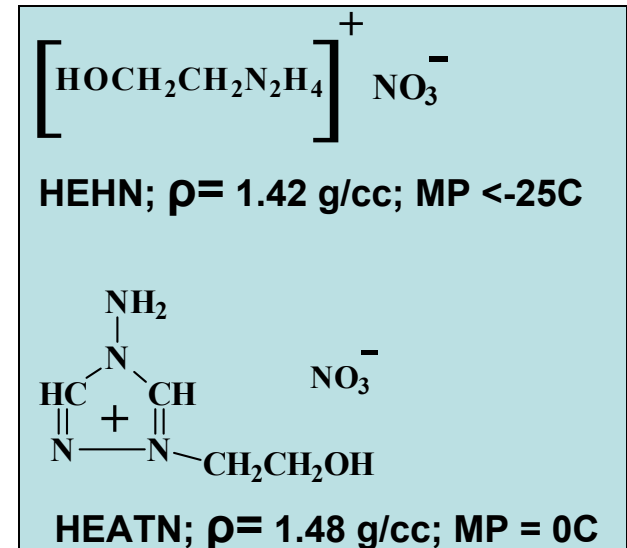



Recent Ionic Liquid Synthesis and Characterization

- Energetic ILs synthesized based on heterocyclic cations
 - Extending foundation of IL work pioneered at AFRL*
 - Recent work in production of higher energy analogues of 1-hydroxyethyl-4-amino-1,2,4-triazolium nitrate
 - Replacement of the hydroxyl with energetic substituents (-CN, -N₃...)
 - Nitrile increases energy content (e.g., ethanol: $\Delta H_f = -1220$ cal/g; acetonitrile: $\Delta H_f = +300$ cal/g)

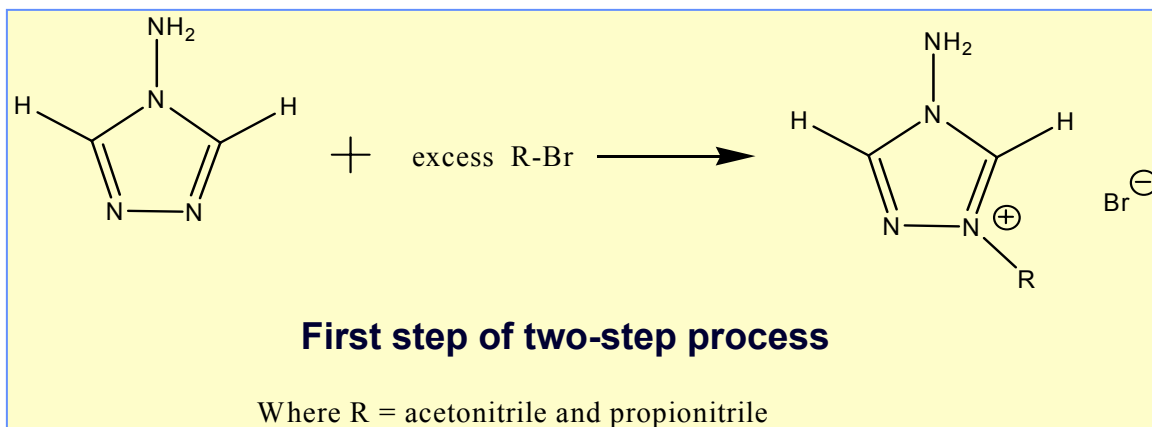

“1-R-4-Amino-1,2,4-triazolium Salts: New Families of Ionic Liquids”, G. Drake, T. Hawkins, K. Tollison, L. Hall, A. Vij and S. Sobaski in ACS Symposium Series 902 (Oxford University Press): Ionic Liquids IV: Fundamentals, Progress, Challenges, and Opportunities (2005)



Recent Ionic Liquid Synthesis and Characterization



- First step successfully performed
 - Crystal structures obtained for bromides
 - Oxygen-bearing anions substitution for next step

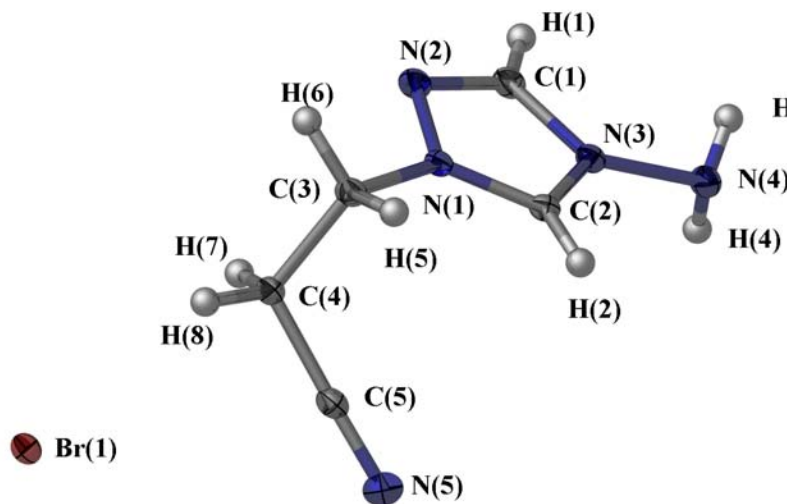

1-cyanoethyl-4-amino-
1,2,4-triazolium bromide

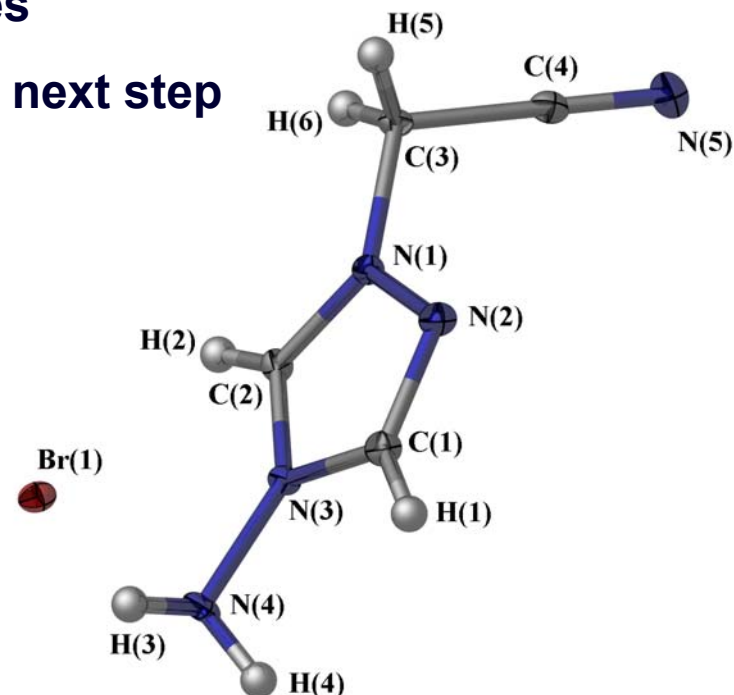

1-cyanomethyl-4-amino-
1,2,4-triazolium bromide



AFRL Ionic Liquids

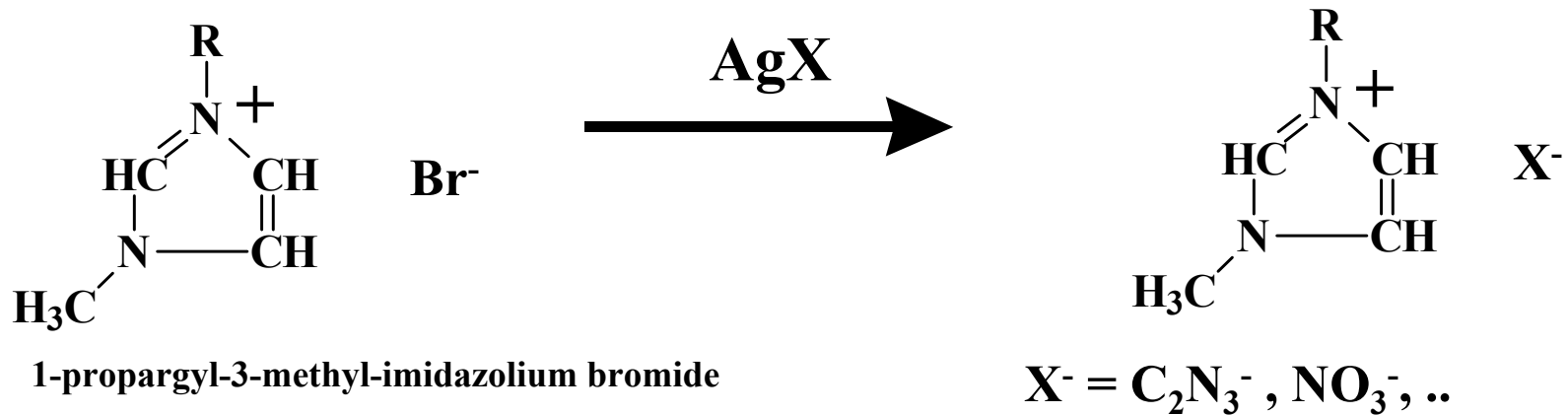

COMPOUND	STRUCTURE	$\Delta H_f/C$ Kcal/mol
Ethane	CH_3CH_3	-5
Ethylene	$\text{CH}_2=\text{CH}_2$	+6.25
Acetylene	$\text{CH}=\text{CH}$	+27.1

<u>SALT</u>	<u>Melting Point</u>	<u>Decomposition Onset</u>
1-propyl-3-methyl-imidazolium bromide*	~ -14 ° C	-
1-allyl-3-methyl-imidazolium bromide	62 ° C	~ 220 ° C
1-propargyl-3-methyl-imidazolium bromide	112 ° C	180 ° C
1-propargyl-3-methyl-imidazolium dicyanamide	15 ° C	143 ° C
1-propargyl-3-methyl-imidazolium nitrate	in progress	in progress

* J.D. Holbrey & R.D. Rogers, "Melting Points and Phase Diagrams", Ionic Liquids in Synthesis, P. Wasserscheid and T. Welton (Eds.), Wiley-VCH (2003).



Ionic Liquid Fuel for Bipropulsion

Goal: Demonstrate feasibility of ionic liquid as fuel for bipropellant systems



Accomplishment

- AFRL/PRSP working with Purdue University has successfully tested high performance ionic liquid fuel in a bipropellant thruster

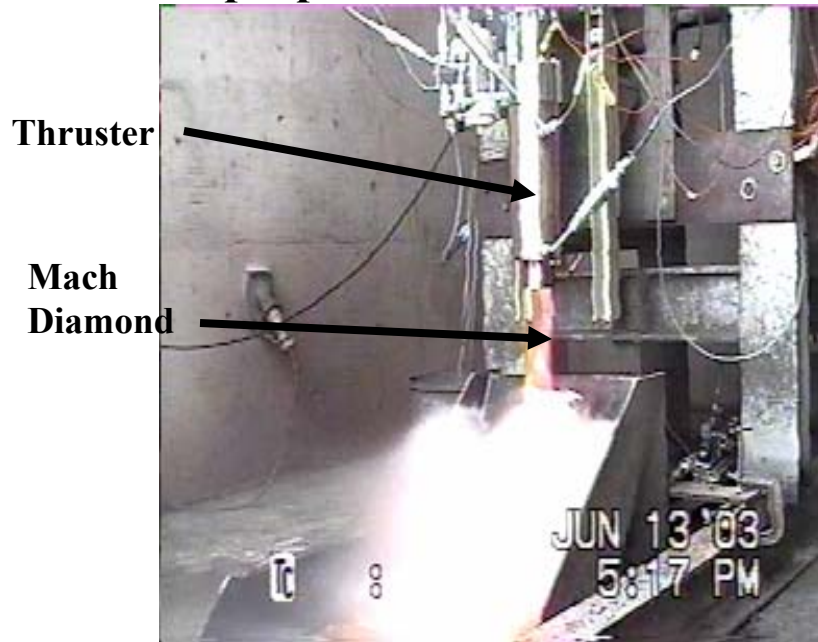

Thruster during bipropellant operation
(93% C* efficiency)

Significance

- Storable bipropellant system with potential increase in performance over NTO/MMH
- Greatly reduced toxicity vs NTO/MMH

Staged bipropellant thruster for ionic liquid fuel

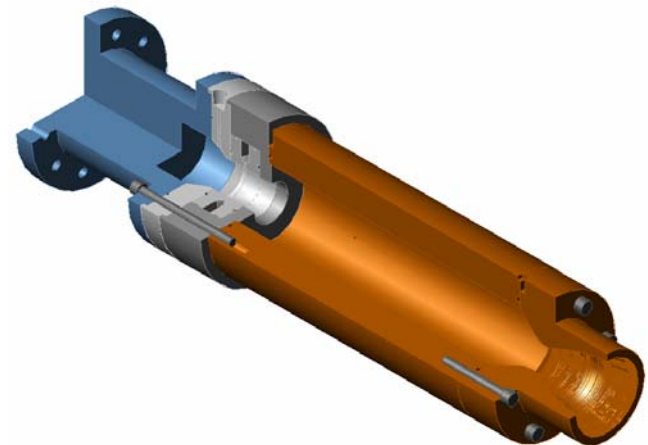



Ionic Liquids in Munitions

- Triazolium salts initially synthesized at USAF
- Scaled to the 50 gram level and characterized in ONR program

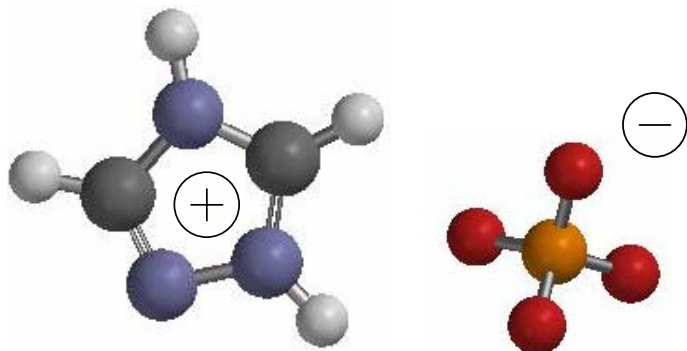

1,2,4-triazolium perchlorate

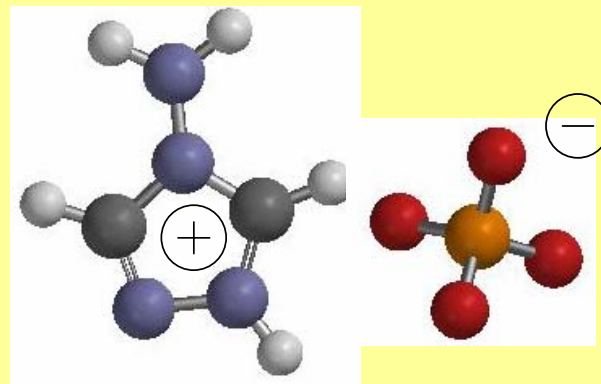

4-amino-1,2,4-triazolium perchlorate
(4-ATP)

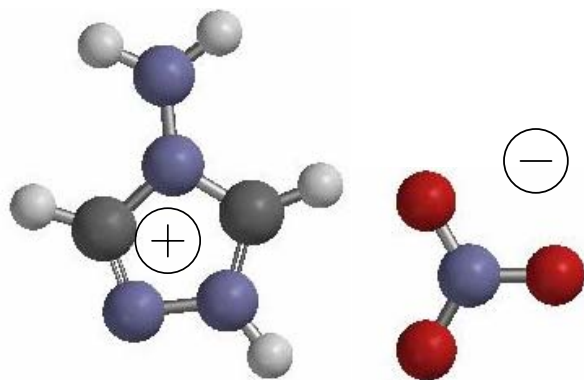

4-amino-1,2,4-triazolium nitrate

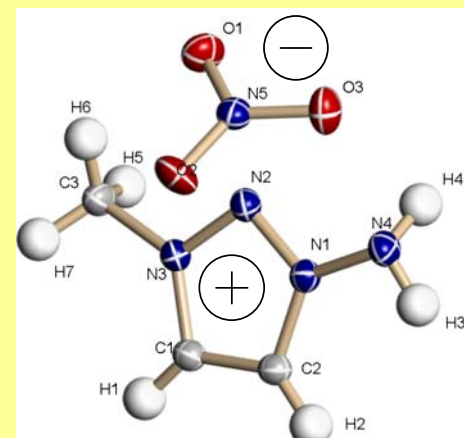

1-amino-3-methyl-1,2,3-triazolium nitrate



Energetic Ionic Liquids for TNT replacements



Very promising initial results!!

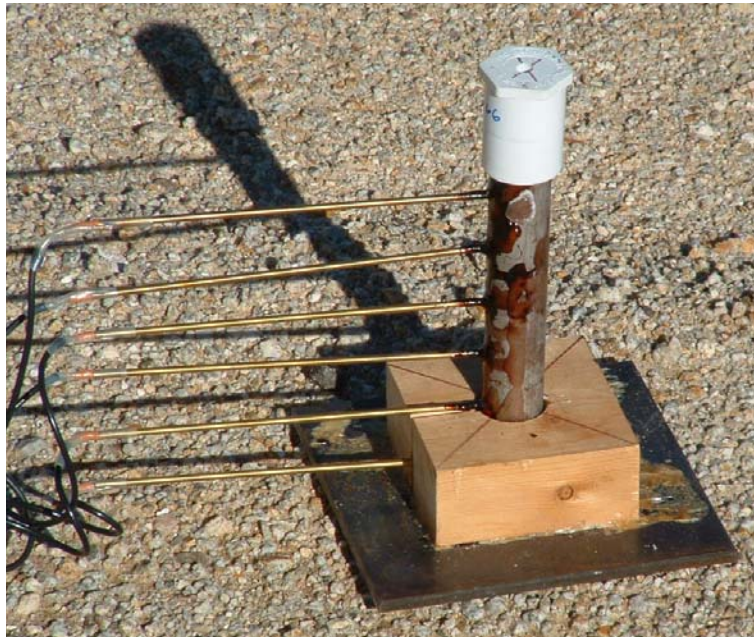

Shock velocity determination

- 4-ATP (melt cast) $\rho = 1.74 \text{ g/cm}^3$; shock velocity = 8.3 mm/usec
- TNT (pressed) $\rho = 1.63 \text{ g/cm}^3$; shock velocity = 6.9 mm/usec (LLNL Data)

4-ATP is approaching energy output of high melt point, state-of-the-art nitramines like RDX !





Theoretical Performance



Calculations indicate that triazolium salts and mixtures are capable of achieving/exceeding performance goals

Ingredients (Composition, Wt/Wt)	Total Detonation Energy (KJ/cc)	Shock Velocity (mm/ μ s)	C-J Pressure (GPa)
TNT	7.716	6.886	19.57
4-ATP	9.032	8.368	29.94
AMTN	7.923	8.115	23.58

- **Research program funded for FY05**
 - **Continues production of IL-based molecules for munitions**
 - **Scale-up of triazole-based ionic liquid in progress for additional characterization**



AFRL Ionic Liquids

Summary and Conclusions

- Both straight chains and heterocycles offer scaffolds for energetic ILs
 - N-amino heterocycles offer a rich platform for ionic liquids
 - Synthesis of novel, heterocycle-based ILs is occurring through introduction of energetic functionalities
 - X-ray crystallography continues to be a powerful tool in our arsenal of characterization tools- confirming structure and identifying interactions in the solid state
 - Understanding ignition and combustion of IL molecules will be a key to future uses
- ILs offer promising avenues for HEDM transition to applications



AFRL Ionic Liquids

Acknowledgements

Collaborators

Greg Drake (NASA-Marshall)
Adam Brand (AFRL/PRSP)
Milton McKay (AFRL/PRSP)
Jo ann Larue (AFRL/PRSP)
Suresh Suri (AFRL/PRSP)
Scott Shackelford (AFRL/PRSP)
B.J. Austin (IN-Space/Purdue)
Steve Heister (Purdue)
Jeff Bottaro (SRI)
Mark Petrie (SRI)
John Wilkes (USAF)

Sponsors

Mike Berman (AFOSR)
Mike Huggins (AFRL/PRSP)
Judah Goldwasser (ONR)
Cliff Bedford (ONR)
Ronald Channell (AFRL/PRSP)
Wayne Kallioma (AFRL/PRSP)
Robert Corley (AFRL/PRS)