



Development of an Apparatus for the Introduction of Biaxial Strain in Thin Polymer Films

*Ken MacKay
Martec Limited*

*Martec Limited
Suite 400, 1888 Brunswick St.
Halifax, NS
B3J 3J8*

Martec Technical Report: TR-04-39

Contract Number: W7707-021914/001/HAL

Contract Scientific Authority: John A. Hiltz, 902-427-0550 x3425

Defence R&D Canada – Atlantic

Contract Report
DRDC Atlantic CR 2004-143
July 2004

Report Documentation Page

Form Approved
OMB No. 0704-0188

Public reporting burden for the collection of information is estimated to average 1 hour per response, including the time for reviewing instructions, searching existing data sources, gathering and maintaining the data needed, and completing and reviewing the collection of information. Send comments regarding this burden estimate or any other aspect of this collection of information, including suggestions for reducing this burden, to Washington Headquarters Services, Directorate for Information Operations and Reports, 1215 Jefferson Davis Highway, Suite 1204, Arlington VA 22202-4302. Respondents should be aware that notwithstanding any other provision of law, no person shall be subject to a penalty for failing to comply with a collection of information if it does not display a currently valid OMB control number.

1. REPORT DATE JUL 2004		2. REPORT TYPE		3. DATES COVERED -	
4. TITLE AND SUBTITLE Development of an Apparatus for the Introduction of Biaxial Strain in Thin Polymer Films				5a. CONTRACT NUMBER	
				5b. GRANT NUMBER	
				5c. PROGRAM ELEMENT NUMBER	
6. AUTHOR(S)				5d. PROJECT NUMBER	
				5e. TASK NUMBER	
				5f. WORK UNIT NUMBER	
7. PERFORMING ORGANIZATION NAME(S) AND ADDRESS(ES) Defence R&D Canada -Atlantic,PO Box 1012,Dartmouth, NS,CA,B2Y 3Z7				8. PERFORMING ORGANIZATION REPORT NUMBER	
9. SPONSORING/MONITORING AGENCY NAME(S) AND ADDRESS(ES)				10. SPONSOR/MONITOR'S ACRONYM(S)	
				11. SPONSOR/MONITOR'S REPORT NUMBER(S)	
12. DISTRIBUTION/AVAILABILITY STATEMENT Approved for public release; distribution unlimited					
13. SUPPLEMENTARY NOTES The original document contains color images.					
14. ABSTRACT The Tailored Polymers Group DRDC Atlantic is involved in the development of dielectric polymer actuators. As part of this research effort, the effect of orientation on the polymer properties will be investigated. This requires the design and fabrication of an apparatus to introduce biaxial strains into thin polymer films. This report describes the work by Martec Limited to design and build such an apparatus. The design allows for strains between 100% and 500% to be applied with the amount of strain controlled by the initial gage length of the specimens. The apparatus allows the strain in the polymer to be maintained after the applied load has been removed. Initial testing showed that the device is capable of introducing and maintaining biaxial strain in two polymer dielectric materials. The maximum strain produced during initial testing was 108.8%, however this was limited by the properties of the supplied materials.					
15. SUBJECT TERMS					
16. SECURITY CLASSIFICATION OF:			17. LIMITATION OF ABSTRACT	18. NUMBER OF PAGES 32	19a. NAME OF RESPONSIBLE PERSON
a. REPORT unclassified	b. ABSTRACT unclassified	c. THIS PAGE unclassified			

This page intentionally left blank.

Development of an Apparatus for the Introduction of Biaxial Strain in Thin Polymer Films

Ken MacKay

Martec Limited
1888 Brunswick Street, Suite 400
Halifax, Nova Scotia
B3J 3J8

Martec Technical Report: TR-04-39

Contract Number: W7707-021914/001/HAL

Contract Scientific Authority: John A. Hiltz, Ph.D.

Defence R&D Canada – Atlantic

Contract Report

DRDC Atlantic CR 2004-143

July 2004

Scientific Authority

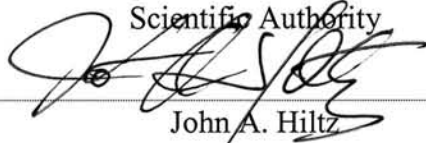

John A. Hiltz

Approved by

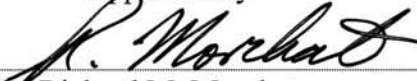

Richard M. Morchat

Section Head Emerging Materials

Approved for release by

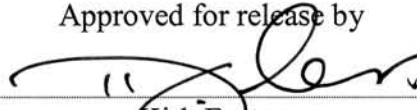

Kirk Foster

DRP Chair

© Her Majesty the Queen as represented by the Minister of National Defence, 2004

© Sa majesté la reine, représentée par le ministre de la Défense nationale, 2004

Abstract

The Tailored Polymers Group DRDC Atlantic is involved in the development of dielectric polymer actuators. As part of this research effort, the effect of orientation on the polymer properties will be investigated. This requires the design and fabrication of an apparatus to introduce biaxial strains into thin polymer films.

This report describes the work by Martec Limited to design and build such an apparatus. The design allows for strains between 100% and 500% to be applied with the amount of strain controlled by the initial gage length of the specimens. The apparatus allows the strain in the polymer to be maintained after the applied load has been removed. Initial testing showed that the device is capable of introducing and maintaining biaxial strain in two polymer dielectric materials. The maximum strain produced during initial testing was 108.8%, however this was limited by the properties of the supplied materials.

Résumé

Le Groupe des polymères adaptés de RDDC Atlantique travaille à la fabrication d'actionneurs polymères diélectriques. Dans le cadre des travaux de recherche, on étudiera l'effet de l'orientation sur les propriétés des polymères. À cette fin, il faut concevoir et fabriquer un appareil permettant de créer des déformations biaxiales dans des films polymères minces.

Le présent rapport décrit les travaux effectués par Martec Limited pour la conception et la fabrication d'un tel appareil. Celui-ci permet d'obtenir des déformations allant de 100 % à 500 %, le niveau de déformation étant fonction de la distance initiale entre repères des éprouvettes. L'appareil permet de maintenir la déformation dans le polymère après la suppression de la charge appliquée. L'essai initial a montré que l'appareil permet de créer et de maintenir une déformation biaxiale dans deux matériaux polymères diélectriques. La déformation maximale produite dans l'essai initial était de 108,8 %, mais elle était limitée en raison des propriétés des matériaux fournis.

This page intentionally left blank.

Executive summary

Introduction

The Tailored Polymers Group DRDC Atlantic is involved in the development of dielectric polymer actuators. The response (strain) of polymer actuators is directly proportional to the square of the breakdown voltage of the polymer. Therefore factors that increase the polymer breakdown voltage will result in marked improvements in the performance of an actuator. One of these factors is the introduction of prestrain to the polymer. As part of this research effort, the effect of polymer orientation (prestrain) on the performance of these actuators is to be investigated. This requires the design and fabrication of an apparatus to introduce biaxial strains into thin polymer films.

Results

An apparatus to introduce biaxial strains into thin polymer films was successfully designed, fabricated and its performance demonstrated. Initial testing has shown that the device is capable of introducing and maintaining biaxial strain in polymer dielectric materials. The average strains obtained at the center of the specimens were 69.8% (2.75 inch gage length) and 108.8% (2.0 inch gage length). The materials tested were not capable of maintaining higher strains in a biaxial loading condition.

The strain at the center of the specimen was 55-59% lower than calculated based on the initial gage length due to the compliance of the specimen arms and displacement near the clamps. Allowances for the arm compliance and displacement near the clamps should be made when determining the initial gage length and desired final strains.

Significance

The apparatus will allow controlled study of the effect of strain on the performance of polymer dielectric materials. This is important in optimizing the performance of polymer dielectric actuators.

Ken Mackay.2004. Development of an Apparatus for the Introduction of Biaxial Strain in Thin Polymer Films. DRDC Atlantic CR 2004-143. DRDC Atlantic.

Sommaire

Introduction

Le Groupe des polymères adaptés de RDDC Atlantique travaille à la fabrication d'actionneurs polymères diélectriques. La réponse (déformation) des actionneurs polymères est directement proportionnelle au carré de la tension de claquage du polymère. Par conséquent, les facteurs qui accroissent la tension de claquage des polymères produisent des améliorations marquées des performances d'un actionneur. Un de ces facteurs consiste en la création d'une prédéformation dans le polymère. Dans le cadre des travaux de recherche, on étudiera l'effet de l'orientation (prédéformation) du polymère sur les performances des actionneurs. À cette fin, il faut concevoir et fabriquer un appareil permettant de créer des déformations biaxiales dans des films polymères minces.

Résultats

On a conçu et fabriqué avec succès un appareil permettant de créer des déformations biaxiales dans des films polymères minces, et on a fait la démonstration de ses performances. L'essai initial a montré que l'appareil permet de créer et de maintenir une déformation biaxiale dans des matériaux polymères diélectriques. Les déformations moyennes obtenues au centre des éprouvettes étaient de 69,8 % (distance entre repères de 2,75 pouces) et 108,8 % (distance entre repères de 2,0 pouces). Dans les matériaux utilisés pour les essais, il était impossible de maintenir des déformations supérieures sous chargement biaxial.

La déformation au centre de l'éprouvette était de 55 à 59 % inférieure à la déformation calculée en fonction de la distance initiale entre repères, en raison de la souplesse des bras de l'éprouvette et du déplacement au voisinage des pièces de fixation. On devrait prévoir des tolérances pour la souplesse des bras et pour le déplacement au voisinage des pièces de fixation lorsqu'on détermine la distance initiale entre repères et les déformations finales voulues.

Portée

L'appareil permet l'étude contrôlée de l'effet de la déformation sur les performances de matériaux polymères diélectriques. Cet aspect est important pour l'optimisation des performances des actionneurs polymères diélectriques.

Ken Mackay, 2004. *Development of an Apparatus for the Introduction of Biaxial Strain in Thin Polymer Films* (Fabrication d'un appareil pour la création de déformations biaxiales dans des films polymères minces). RDDC Atlantique CR 2004-143.

Table of contents

Abstract.....	i
Executive summary	iii
Sommaire.....	iv
Table of contents	v
List of figures	vi
1. Introduction	1
2. Design of a Biaxial Strain Apparatus for Thin Film Dielectric Polymer	2
2.1 Design Requirements.....	2
2.2 General Approach.....	2
2.3 Design Details	3
2.4 Specimen Design and Fabrication	3
3. Demonstration of the Biaxial Strain Apparatus.....	6
4. Conclusions and Recommendations.....	10
Annexes	11
Distribution list.....	17

List of figures

- Figure 1. Sketch of general approach for proposed apparatus: A) specimen (yellow) clamped to first set of rails, B) second set of rails clamped to sides of strained specimen, and C) specimen strained in both directions and rails locked in place at the end of test. 4
- Figure 2. Assembly drawing of the apparatus (fasteners not shown, dimensions in inches). 4
- Figure 3. Photograph of the apparatus..... 5
- Figure 4. Specimen configurations. Left: Specimen GP-3-51 with 2.75” gage section. Right: Specimen HSIII-ALS05 with 2” gage section. 5
- Figure 5. Specimen GP-3-51. Top left: unstrained. Top right: strained in one direction. Center: final strained state. Bottom: strains at center of specimen.. 8
- Figure 6. Specimen HSIII-ALS05: Top left: unstrained. Top right: strained in one direction. Center: final strained state. Bottom: strains at center of specimen.. 9

1. Introduction

One of the research efforts at DRDC Atlantic involves the development of dielectric actuators. The effect of orientation on the polymer dielectric properties is to be investigated as part of this research effort. In support of these material characterization activities, a biaxial strain apparatus was required. Martec Limited was contracted to design such an apparatus for DRDC Atlantic. This report describes the design, fabrication, testing and installation of the apparatus to introduce biaxial strains into thin polymer films. The device will also allow the operator to remove the strained polymer from the device while maintaining the introduced strain.

2. Design of a Biaxial Strain Apparatus for Thin Film Dielectric Polymer

2.1 Design Requirements

Requirements for the device were specified as follows:

1. The apparatus will introduce strains between 100% and 500%.
2. Once the desired strain is reached, the apparatus will allow for subsequent analysis or post-cure treatment of the strained polymer.
3. The apparatus will accommodate samples with initial gage lengths ranging from 1 to 3 inches. Gage length refers to unstrained length of the polymer.
4. The apparatus must contain electrodes to allow a voltage to be applied to the material in its strained state.

The apparatus must be capable of use with existing test frames and as a manually driven device.

2.2 General Approach

The apparatus consists of four rails that will clamp the four sides of the specimen. The basic operation of the device is shown in Figure 1. Initially the specimen is clamped to two rails and rails separated. The second set of rails is attached to the first set of rails and the free sides of the specimens clamped. The attachment of the second set of rails to the first set of rails allows the second set of rails to move perpendicular to the first while maintaining the distance between the first set of rails, and therefore, the strain in that direction. The second set of rails is then moved apart and locked in place to maintain the strain in the second direction.

The rails are designed such that they can be attached to a variety of test frames. Load and displacement of the specimen are measured by the test frame. One of the test frames used for testing dielectric actuators utilizes a chamber to prevent electric discharge when applying high voltage fields. The apparatus was designed to operate within this chamber. If load and displacement measurements are not required, strain can be introduced by separating the rails manually.

A grid pattern deposited on the surface of the specimen prior to testing is used to determine the strain in the specimen. Digital images of the patterns taken prior to and after biaxial stretching are used to determine the detailed strain patterns.

2.3 Design Details

The assembly drawing and a photograph of the apparatus are shown in Figures 2 and 3 respectively. Detailed machine drawings are given in Appendix A. The rails and clamp blocks are machined from PVC. Up to 4 plastic fasteners can be used to attach each clamp block to the rails. However, it was discovered during testing that 2 fasteners per clamp block were sufficient to hold the specimens. Two of the clamp blocks contain 0.5" diameter brass electrodes for applying a voltage to the specimen. The surfaces of the clamp electrodes were ground with 320 grit paper, whereas the other clamping surfaces were left in their as-manufactured finish. The side rails contain a T-shaped slot to accommodate the top and bottom rails. These slots had to be enlarged slightly to allow for the relaxation of the PVC material after milling the slots. The slots were also machined to provide 0.010" difference in elevation between the side rails and top and bottom rails. This elevation difference allows the side rails to pass underneath a specimen clamped to the top and bottom rails. The rails are locked in place by installing plastic fasteners in the holes at the end of the rails.

2.4 Specimen Design and Fabrication

The final gage length between the rails is approximately 6" and therefore the initial gage length of the specimen will determine the amount of strain developed in the specimen. Note that due to the nature of the materials there will be some slip at the clamp blocks during loading so the effective final gage length will be less than 6". The shape of the specimen used during initial testing was a cross-shaped section (see Figure 4). The 4 arms of the specimen are clamped to the side rails. A large radius is used between the arms to reduce the stress concentration at these locations. Care must be taken when cutting the specimens to prevent any defects that could act as stress raisers and initiate failure of the specimens before the desired strain is achieved.

A grid pattern was applied to the specimens before cutting them from the sheet of material. Ballpoint pens were used to apply the marking on the specimens. It was important that the pen did not require much force to operate, as light pressure was required to prevent tearing of the material. Best results were achieved with medium point "Gel" ballpoint pens. Felt tip markers were not used, as there was concern the solvent in the ink could damage the specimen. Water based inks were also tried however they did not adhere well to the test samples.

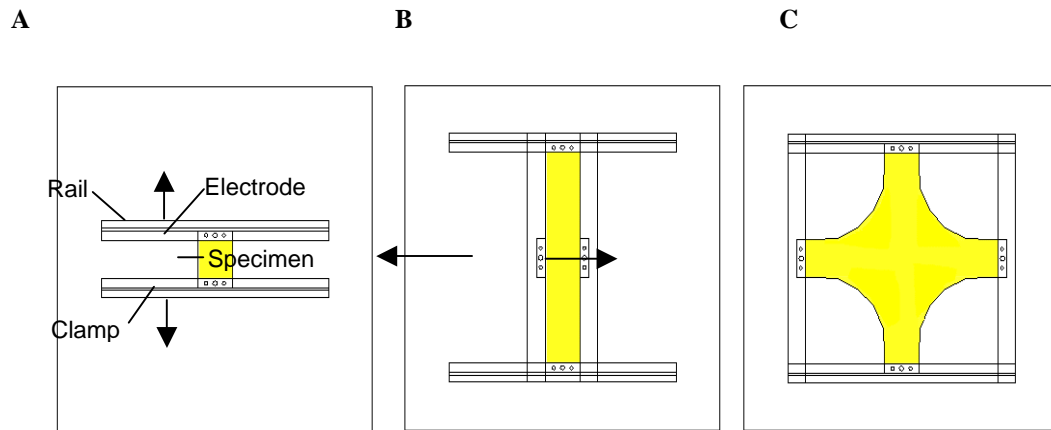

Figure 1. Sketch of general approach for proposed apparatus: A) specimen (yellow) clamped to first set of rails, B) second set of rails clamped to sides of strained specimen, and C) specimen strained in both directions and rails locked in place at the end of test.

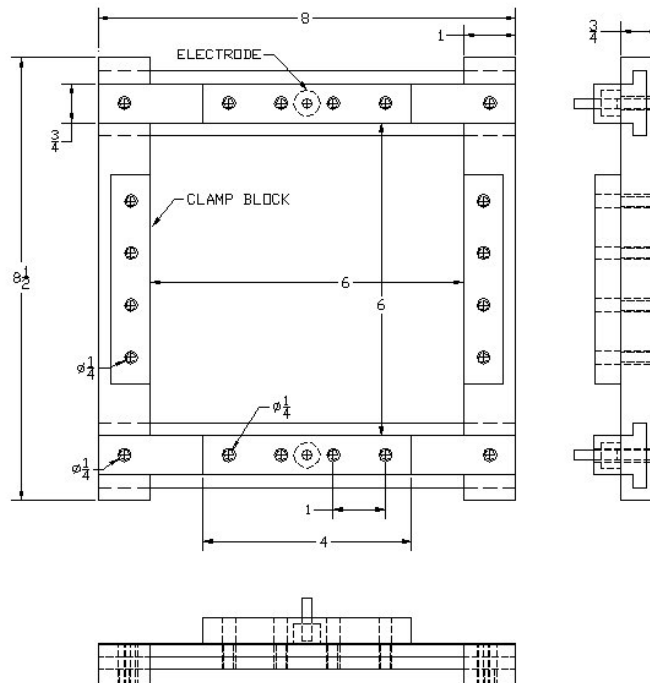

Figure 2. Assembly drawing of the apparatus (fasteners not shown, dimensions in inches).

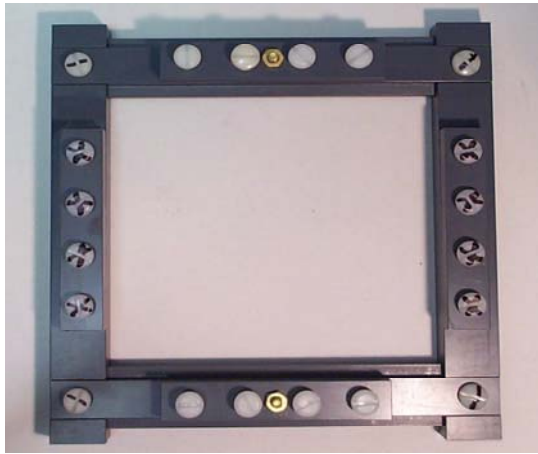

Figure 3. Photograph of the apparatus..

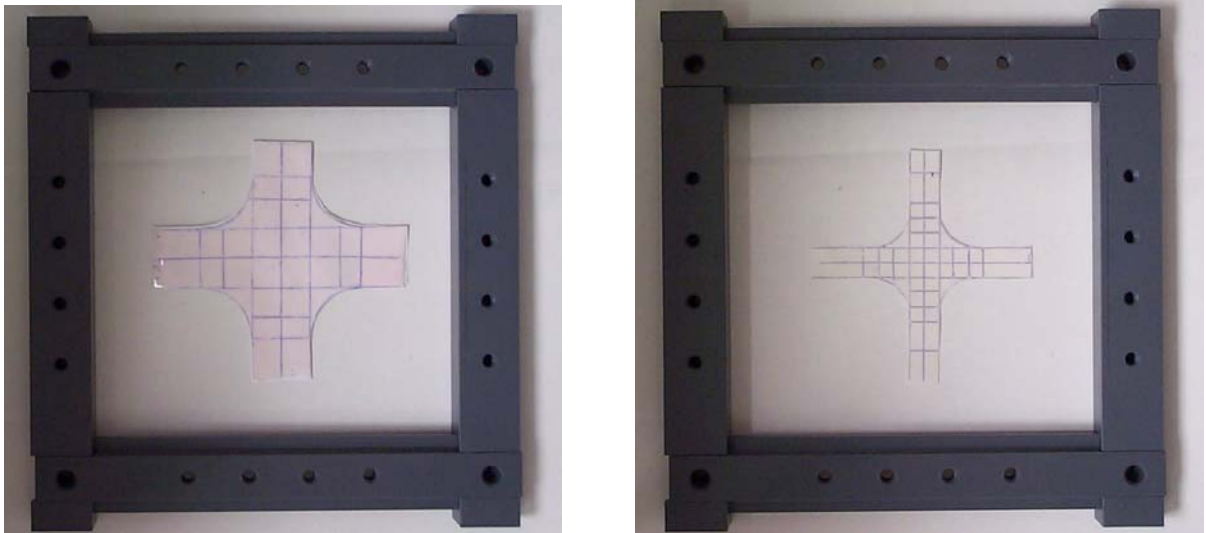

Figure 4. Specimen configurations. Left: Specimen GP-3-51 with 2.75" gage section. Right: Specimen HSIII-ALS05 with 2" gage section.

3. Demonstration of the Biaxial Strain Apparatus

Experimental testing was performed to verify the operation and performance of the apparatus. The strain produced in the test specimens was characterized by observing the geometric displacement changes of a grid pattern deposited on to the surface of the specimens prior to testing. The results from two specimens are given in Figures 5 and 6. In both cases the specimens were loaded manually. The specimens were left for several hours before strain measurements were taken to allow for potential relaxation of the specimen.

Specimen GP-3-51, shown in Figure 5, developed an average strain of 69.8% in its central section (measured along the 4 lines radiating from the center of the specimen). The strains at the center of the specimen were relatively uniform, ranging from 68.0% to 71.4 %. The strains became significantly more uniaxial away from the center of the specimen, with the transverse strains ranging from, 42% to 54% around the periphery of the center square, and the axial strains approaching 126% in the outer arms of the specimen. The strains in the specimen are relatively symmetric with respect to the orthogonal axes of the specimen. It was discovered that it was possible to partially release the clamping pressure once the specimen was loaded to allow for some adjustment of the strain in each of the arms.

The central strain of 69.8% is well below the strain calculated from the initial gage length of the polymer (118%). One factor attributing to this is that the arms of the specimen are more compliant than the center of the specimen and develop much higher strains (125% on average for this specimen) in the direction of the displacement. The other factor is that when loading the specimen there is some displacement of the specimen relative to the clamps. The lines initially at the edge of the clamps displaced approximately 0.35 inches towards the center of the specimen for GP-3-51.

Specimen HSIII-ALS05, shown in Figure 6, developed an average strain of 108.8%, which again is well below the strain based on a 2 inch gage length (i.e. 200%). However, there is some displacement near the clamps (approximately 0.5 inches) and the axial strains in the arms are quite high (approximately 200%). Unlike the previous specimen, the strains are not uniform in the center of the specimen. Strains along the 4 central lines ranged from 99.9% to 118.2%. Adjusting the strains in each arm by partially releasing the clamps made some improvement but it was not possible to obtain a uniform strain distribution in the specimen. Upon closer inspection, it was discovered that the material from which the specimen was cut was not of uniform thickness, with one end nearly twice the thickness of the other.

Both specimens were held in the strained position for a minimum of 3 days to demonstrate that the strains could be maintained over a period of time. Measurements taken at selected points on each specimen revealed that there was no measurable difference in the strains after 3 days.

Attempts were made to produce higher strains in the specimens described above by reducing the gage length. The specimens were removed from the apparatus and clamped closer to the center to reduce the gage length to 2.5 inches for the GP-3-51 specimen and to 1.5" for the HSIII-ALS05 specimen. One of the arms of the GP-3-51 specimen failed during loading. The

HSIII-ALS05 specimen was loaded successfully but developed a tear after several hours. The tear initiated in the radius between two of the arms. Another HSIII-ALS05 specimen was tested but again the specimen failed shortly after loading. Material data was not available for the materials tested, however it is suspected that the loads were approaching the failure strength of the material.

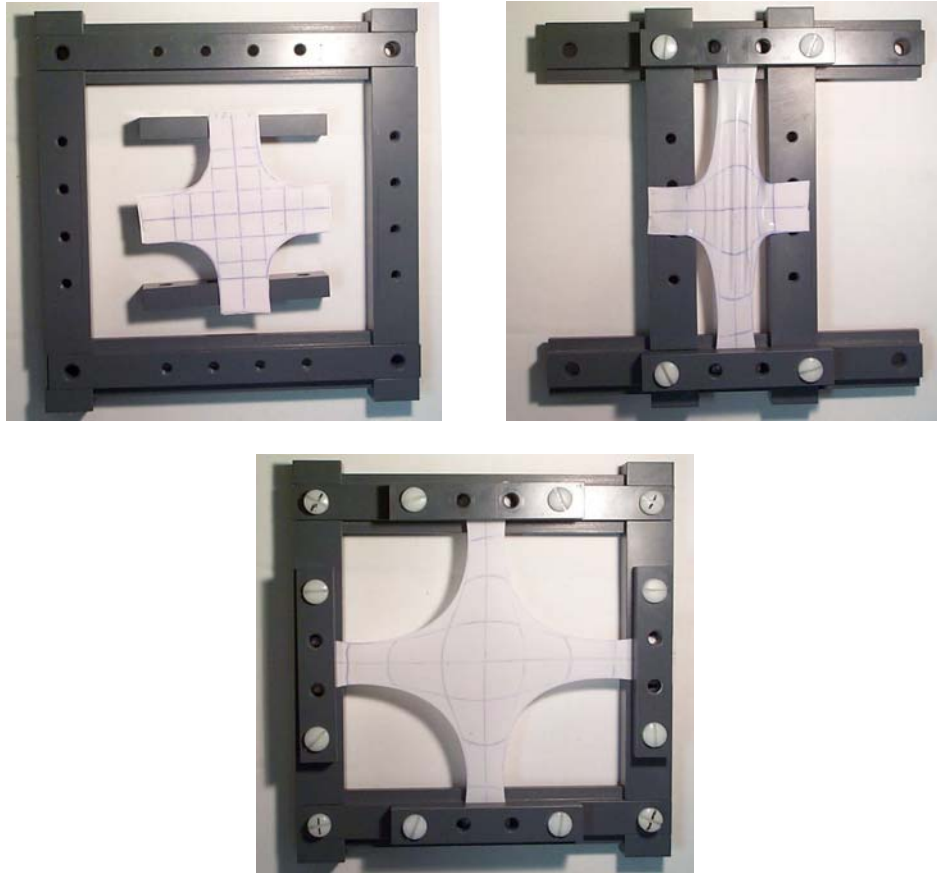

	50.2%	42.5%
51.5%	70.7%	54.3%
44.8%	71.4%	68.9%
	68.0%	43.8%
	48.3%	50.3%

Figure 5. Specimen GP-3-51. Top left: unstrained. Top right: strained in one direction. Center: final strained state. Bottom: strains at center of specimen..

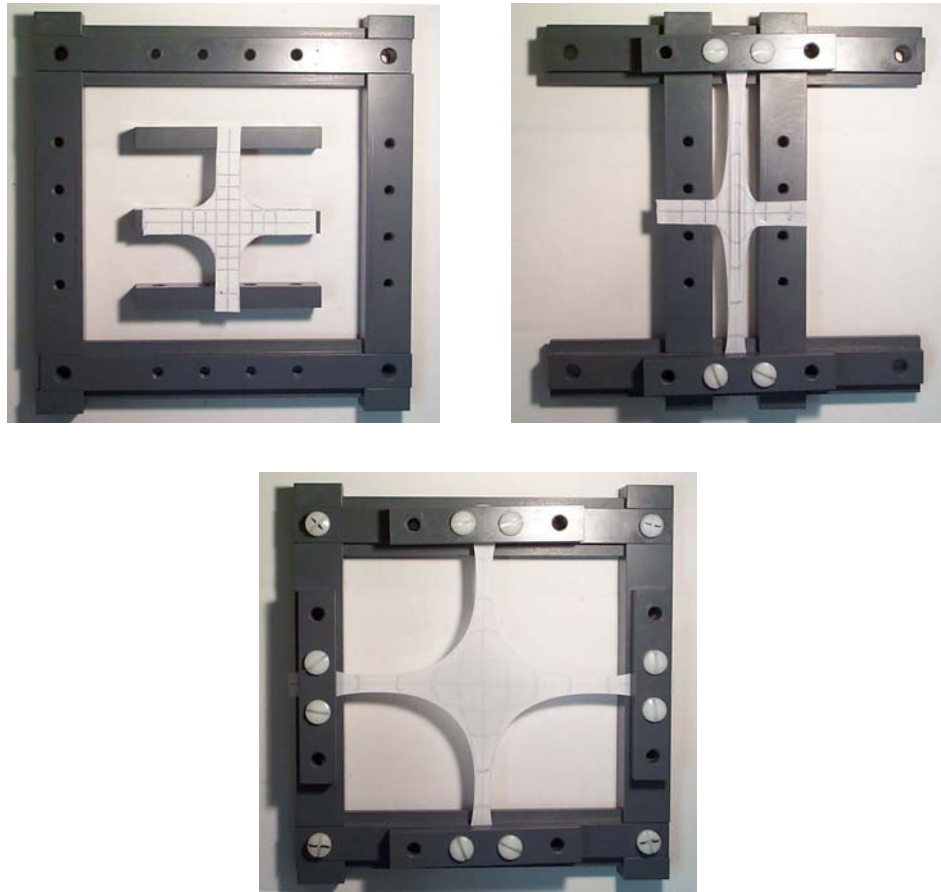

	72.1%	98.0%	
80.9%		104.4%	80.2%
	99.9%	118.2%	
103.0%		112.7%	105.5%
	75.8%	86.7%	

Figure 6. Specimen HSIII-ALS05: Top left: unstrained. Top right: strained in one direction. Center: final strained state. Bottom: strains at center of specimen..

4. Conclusions and Recommendations

An apparatus to introduce biaxial strains into thin polymer films was successfully designed, fabricated and its performance demonstrated.

Initial testing has shown that the device is capable of introducing and maintaining biaxial strain in polymer dielectric materials.

The average strains obtained at the center of the specimens were 69.8% (2.75 inch gage length) and 108.8% (2.0 inch gage length). The materials tested were not capable of maintaining higher strains in a biaxial loading condition.

The strain at the center of the specimen was 55-59% lower than calculated based on the initial gage length due to the compliance of the specimen arms and displacement near the clamps. Allowances for the arm compliance and displacement near the clamps should be made when determining the initial gage length and desired final strains.

Annexes

Machine Drawings

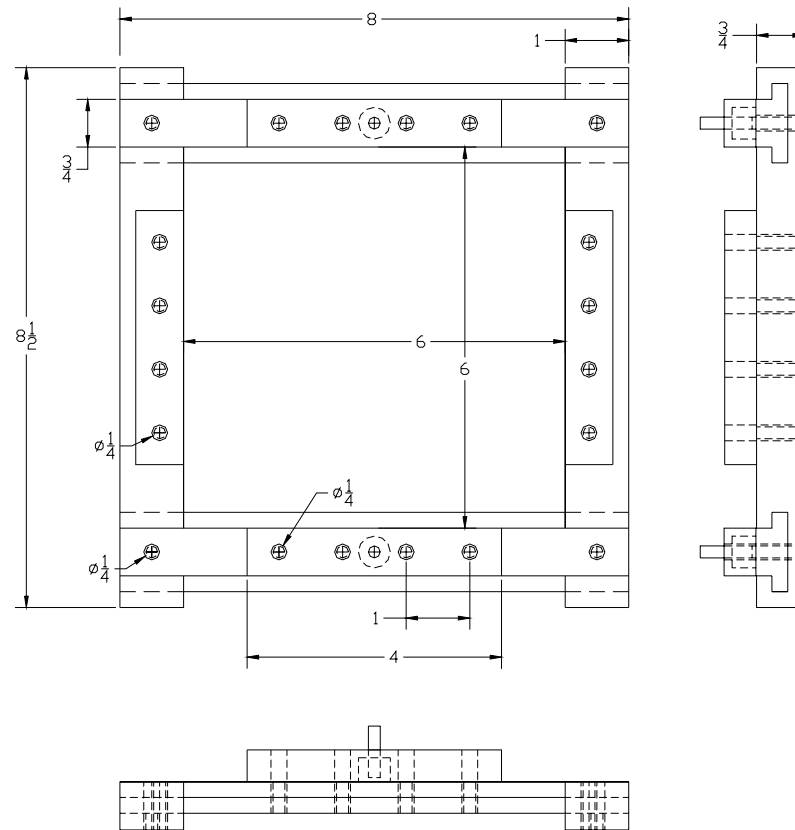

APPROVED: _____		APPROVE: _____		SIZE: GRANDEUR:	QUANTITY: QUANTITE:
CHECKED BY: _____		VERIFIE: _____		MATERIAL: _____	MATERIAL: _____
TOLERANCES: _____		DRAWN BY: DESSEINE PAR: K.MACKAY		PROJECT: 81005.01	
UNITS: _____		SCALE: _____		PROJECT: 81005.01	
UNITS: _____		DATE: 05/8/03		DRAWING NUMBER: 81005.01-01	
		MARTEC LTD 1888 BRUNSWICK STREET, SUITE 400 HALIFAX, NS, B3J 3J8, CANADA		NUMERO DE DESSIN: _____	
		DESCRIPTION: BIAxIAL STRAIN FIXTURE		SHEET FEUILLE: 1 OF DE 1	

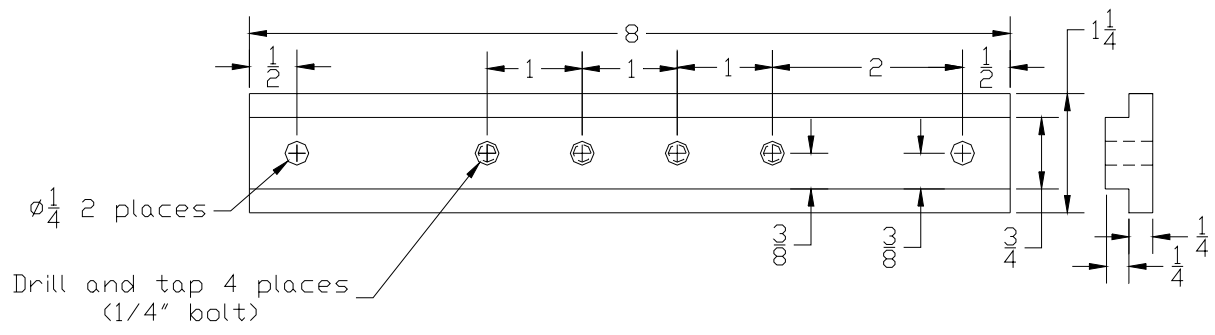

APPROVED:	APPROVE:	MARTEC LTD 1888 BRUNSWICK STREET, SUITE 400 HALIFAX, NS, B3J 3J8, CANADA		SIZE:	GRANDEUR:	QUANTITY:	QUANTITE:
CHECKED BY:	VERIFIE:			MATERIAL:	MATERIAU:	1	
TOLERANCES:	DRAWN BY: DESSINE PAR:	K. MACKAY		PROJECT:		81005.01	
UNLESS OTHERWISE NOTED:	SCALE: ECHELLE:	DESCRIPTION: END RAIL, BIAxIAL STRAIN FIXTURE		DRAWING NUMBER:		NUMERO DE DESSIN:	
UNITS:	UNITE:	DATE:	05/8/03	DRAWING NUMBER:		81005.01-02	
				SHEET:		1 OF 1	
				FEUILLE:		1 DE 1	

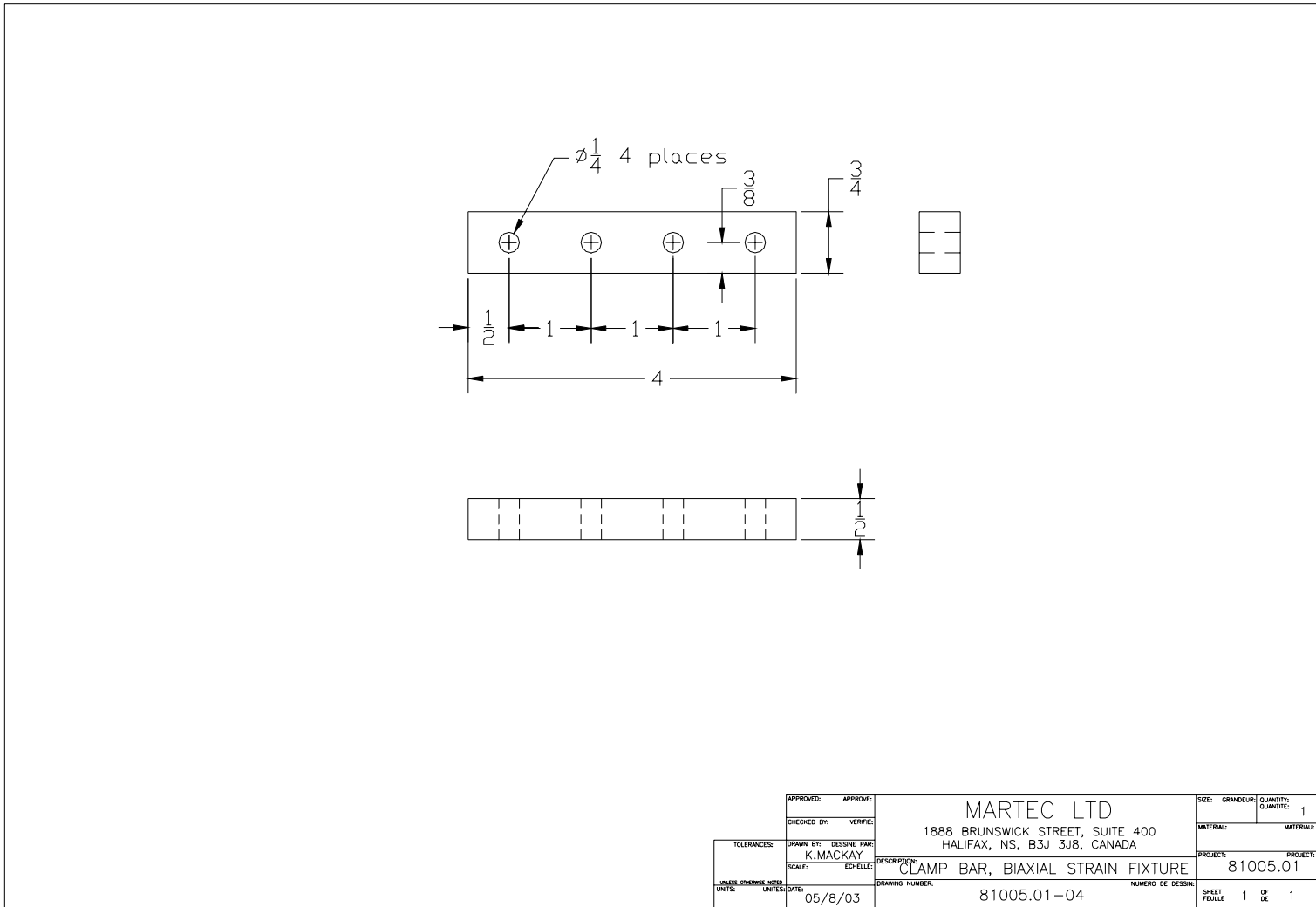

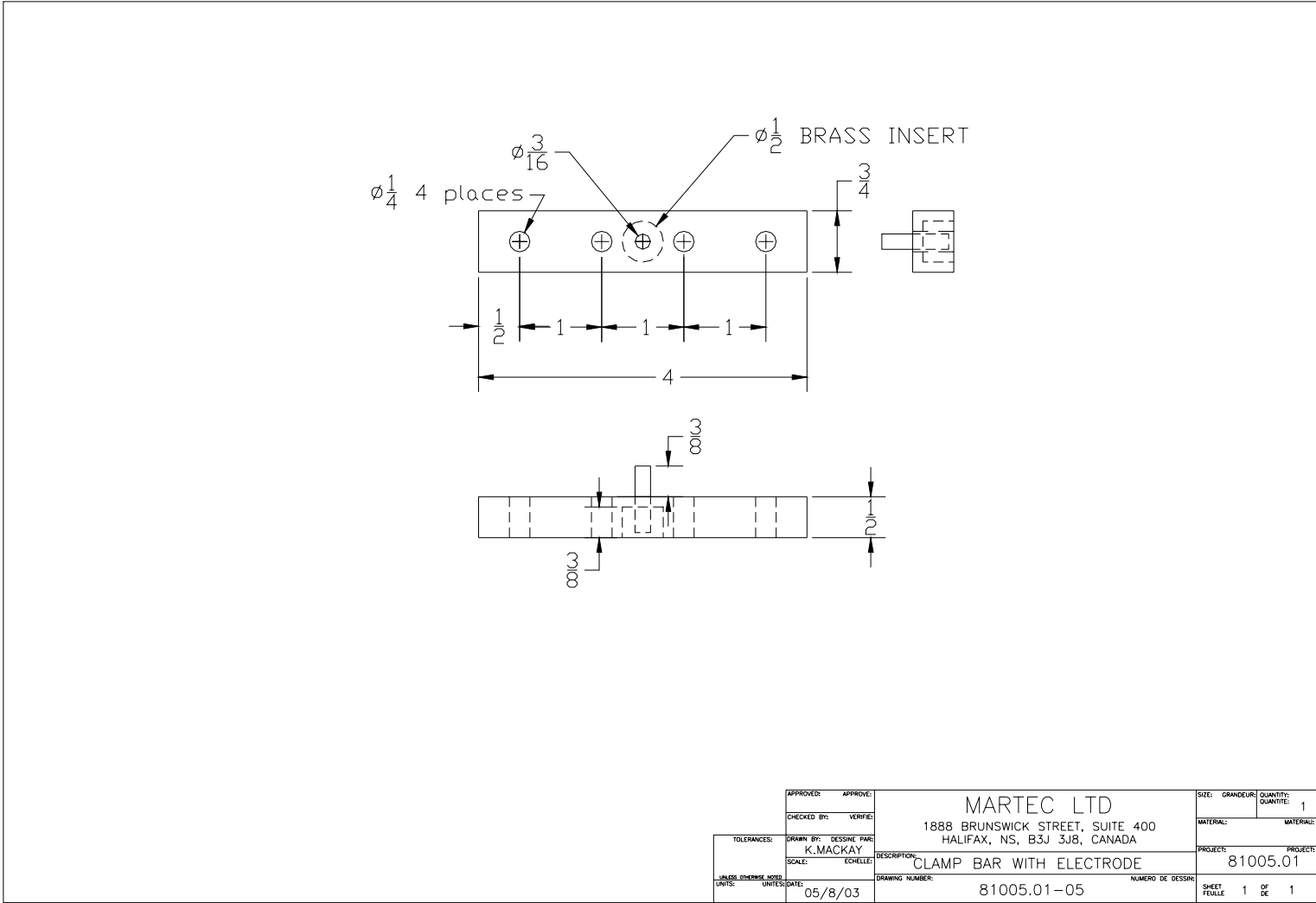

APPROVED:		APPROVEE:		SIZE: GRANDEUR:	QUANTITY: QUANTITE:
CHECKED BY: VÉRIFIÉ:		MARTEC LTD		1	
DRAWN BY: DESSINÉ PAR:		1888 BRUNSWICK STREET, SUITE 400		MATERIAL: MATÉRIEL:	
K.MACKAY		HALIFAX, NS, B3J 3J8, CANADA		PROJECT: PROJET:	
SCALE: ÉCHELLE:		DESCRIPTION: CLAMP BAR WITH ELECTRODE		81005.01	
UNITS: UNITÉS:		DRAWING NUMBER: 81005.01-05		NUMERO DE DESSIN:	
DATE: 05/8/03				SHEET FEUILLE 1 OF DE 1	

Distribution list

LIST PART 1: CONTROLLED BY DRDC ATLANTIC LIBRARY

<u>3</u>	DRDC ATALNTIC LIBRARY FILE COPIES
<u>3</u>	DRDC ATLANTIC LIBRARY (SPARES)
<u>4</u>	Scientific Authority
<u>1</u>	GL Tailored Polymers
<u>2</u>	Author (Mr. Ken MacKay, Martec)
<u>2</u>	Section Heads EMERGING MATERIALS and DL(P)
<hr/>	
<u>15</u>	<u>TOTAL LIST PART 1</u>

LIST PART 2: DISTRIBUTED BY DRDKIM 3

<u>1</u>	NDHQ/ DRDC/ DRDKIM 3 (scanned and stored as black & white image, low resolution - laser reprints available on request)
<hr/>	
<u>1</u>	<u>TOTAL LIST PART 2</u>

16 TOTAL COPIES REQUIRED

Original document held by DRDC Atlantic

Any requests by DRDC Atlantic staff for extra copies of this document should be directed to the DRDC Atlantic LIBRARY.

This page intentionally left blank.

DOCUMENT CONTROL DATA

(Security classification of title, body of abstract and indexing annotation must be entered when the overall document is classified)

1. ORIGINATOR (the name and address of the organization preparing the document. Organizations for whom the document was prepared, e.g. Centre sponsoring a contractor's report, or tasking agency, are entered in section 8.) Martec Limited, 1888 Brunswick Street, Suite 400, Halifax, Nova Scotia B3J 3J8		2. SECURITY CLASSIFICATION <input type="checkbox"/> (overall security classification of the document including special warning terms if applicable). UNCLASSIFIED	
3. TITLE (the complete document title as indicated on the title page. Its classification should be indicated by the appropriate abbreviation (S,C,R or U) in parentheses after the title). Development of an Apparatus for the Introduction of Biaxial Strain in Thin Polymer Films			
4. AUTHORS (Last name, first name, middle initial. If military, show rank, e.g. Doe, Maj. John E.) MackKay, Ken			
5. DATE OF PUBLICATION (month and year of publication of document) July 2004		6a. NO. OF PAGES (total containing information Include Annexes, Appendices, etc). 17 (approx.)	6b. NO. OF REFS (total cited in document) 0
7. DESCRIPTIVE NOTES (the category of the document, e.g. technical report, technical note or memorandum. If appropriate, enter the type of report, e.g. interim, progress, summary, annual or final. Give the inclusive dates when a specific reporting period is covered). Contractor Report			
8. SPONSORING ACTIVITY (the name of the department project office or laboratory sponsoring the research and development. Include address). Defence R&D Canada – Atlantic PO Box 1012 Dartmouth, NS, Canada B2Y 3Z7			
9a. PROJECT OR GRANT NO. (if appropriate, the applicable research and development project or grant number under which the document was written. Please specify whether project or grant). 11gm12		9b. CONTRACT NO. (if appropriate, the applicable number under which the document was written). Contract Number: W7707- 021914/001/HAL	
10a. ORIGINATOR'S DOCUMENT NUMBER (the official document number by which the document is identified by the originating activity. This number must be unique to this document.) Martec Technical Report: TR-04-39		10b. OTHER DOCUMENT NOS. (Any other numbers which may be assigned this document either by the originator or by the sponsor.) DRDC Atlantic CR 2004-143	
11. DOCUMENT AVAILABILITY (any limitations on further dissemination of the document, other than those imposed by security classification) (<input checked="" type="checkbox"/>) Unlimited distribution () Defence departments and defence contractors; further distribution only as approved () Defence departments and Canadian defence contractors; further distribution only as approved () Government departments and agencies; further distribution only as approved () Defence departments; further distribution only as approved () Other (please specify):			
12. DOCUMENT ANNOUNCEMENT (any limitation to the bibliographic announcement of this document. This will normally correspond to the Document Availability (11). However, where further distribution (beyond the audience specified in (11) is possible, a wider announcement audience may be selected). Unlimited			

13. **ABSTRACT** (a brief and factual summary of the document. It may also appear elsewhere in the body of the document itself. It is highly desirable that the abstract of classified documents be unclassified. Each paragraph of the abstract shall begin with an indication of the security classification of the information in the paragraph (unless the document itself is unclassified) represented as (S), (C), (R), or (U). It is not necessary to include here abstracts in both official languages unless the text is bilingual).

The Tailored Polymers Group DRDC Atlantic is involved in the development of dielectric polymer actuators. As part of this research effort, the effect of orientation on the polymer properties will be investigated. This requires the design and fabrication of an apparatus to introduce biaxial strains into thin polymer films.

This report describes the work by Martec Limited to design and build such an apparatus. The design allows for strains between 100% and 500% to be applied with the amount of strain controlled by the initial gage length of the specimens. The apparatus allows the strain in the polymer to be maintained after the applied load has been removed. Initial testing showed that the device is capable of introducing and maintaining biaxial strain in two polymer dielectric materials. The maximum strain produced during initial testing was 108.8%, however this was limited by the properties of the supplied materials.

14. **KEYWORDS, DESCRIPTORS or IDENTIFIERS** (technically meaningful terms or short phrases that characterize a document and could be helpful in cataloguing the document. They should be selected so that no security classification is required. Identifiers, such as equipment model designation, trade name, military project code name, geographic location may also be included. If possible keywords should be selected from a published thesaurus. e.g. Thesaurus of Engineering and Scientific Terms (TEST) and that thesaurus-identified. If it not possible to select indexing terms which are Unclassified, the classification of each should be indicated as with the title).

biaxial strain

apparatus

polymer films

orientation

This page intentionally left blank.

Defence R&D Canada

Canada's leader in defence
and national security R&D

R & D pour la défense Canada

Chef de file au Canada en R & D
pour la défense et la sécurité nationale



www.drdc-rddc.gc.ca