

A Remotely Operated Firing System for Small Arms Weapons

R.J. Swinton and M. Vogl

**Weapons Systems Division
Aeronautical and Maritime Research Laboratory**

DSTO-TN-0005

ABSTRACT

A system and procedure is described for the remote firing of a 50 calibre weapon for firing projectiles into explosive samples only 2m away. The system can be used for laboratory or field firings and its major features are:

- (i) an electrically actuated solenoid firing mechanism and
- (ii) a linear actuator line-of-fire interrupter plate.

Field testing has demonstrated that the apparatus is safe and reliable. A set of firing and operating instructions have been successfully implemented and are included as an Appendix.

RELEASE LIMITATION

Approved for public release

D E P A R T M E N T O F D E F E N C E

DEFENCE SCIENCE AND TECHNOLOGY ORGANISATION

Report Documentation Page

*Form Approved
OMB No. 0704-0188*

Public reporting burden for the collection of information is estimated to average 1 hour per response, including the time for reviewing instructions, searching existing data sources, gathering and maintaining the data needed, and completing and reviewing the collection of information. Send comments regarding this burden estimate or any other aspect of this collection of information, including suggestions for reducing this burden, to Washington Headquarters Services, Directorate for Information Operations and Reports, 1215 Jefferson Davis Highway, Suite 1204, Arlington VA 22202-4302. Respondents should be aware that notwithstanding any other provision of law, no person shall be subject to a penalty for failing to comply with a collection of information if it does not display a currently valid OMB control number.

1. REPORT DATE JUL 1995	2. REPORT TYPE N/A	3. DATES COVERED -		
4. TITLE AND SUBTITLE A Remotely Operated Firing System for Small Arms Weapons		5a. CONTRACT NUMBER		
		5b. GRANT NUMBER		
		5c. PROGRAM ELEMENT NUMBER		
6. AUTHOR(S)		5d. PROJECT NUMBER		
		5e. TASK NUMBER		
		5f. WORK UNIT NUMBER		
7. PERFORMING ORGANIZATION NAME(S) AND ADDRESS(ES) DSTO Aeronautical and Maritime Research Laboratory PO Box 4331 Melbourne Victoria 3001		8. PERFORMING ORGANIZATION REPORT NUMBER		
9. SPONSORING/MONITORING AGENCY NAME(S) AND ADDRESS(ES)		10. SPONSOR/MONITOR'S ACRONYM(S)		
		11. SPONSOR/MONITOR'S REPORT NUMBER(S)		
12. DISTRIBUTION/AVAILABILITY STATEMENT Approved for public release, distribution unlimited				
13. SUPPLEMENTARY NOTES				
14. ABSTRACT				
15. SUBJECT TERMS				
16. SECURITY CLASSIFICATION OF:			17. LIMITATION OF ABSTRACT	
a. REPORT unclassified	b. ABSTRACT unclassified	c. THIS PAGE unclassified	UU	18. NUMBER OF PAGES 30
				19a. NAME OF RESPONSIBLE PERSON

Published by

*DSTO Aeronautical and Maritime Research Laboratory
PO Box 4331
Melbourne Victoria 3001*

Telephone: (03) 9626 8111

Fax: (03) 9626 8999

© Commonwealth of Australia 1995

AR No. 009-209

July 1995

APPROVED FOR PUBLIC RELEASE

Contents

1. INTRODUCTION.....	1
2. GENERAL DESCRIPTION OF SET-UP AND SYSTEM.....	1
3. SAFETY FEATURES.....	2
4. COMPONENT DESCRIPTION AND FUNCTION.....	3
4.1 Solenoid Firing System.....	3
4.2 Line-of-Fire Interrupter.....	3
4.3 Blast Deflection.....	4
4.4 Barrel Alignment.....	5
5. LESSONS FROM FIELD TRIALS.....	5
5.1 Solenoid.....	5
5.2 Linear Actuator.....	5
6. INSTRUMENT OPTIONS.....	6
7. CONCLUSIONS.....	6
8. ACKNOWLEDGEMENTS.....	6
9. REFERENCES.....	7
APPENDIX 1 - PROPOSED FIRING INSTRUCTIONS.....	8

1. Introduction

When working with energetic materials such as explosives where the degree of response to an applied stimulus can be quite catastrophic there often arises the situation where a fail-safe remotely operated firing system is required. Aeronautical and Maritime Research Laboratory (AMRL) is currently investigating the effects of projectile impact on energetic materials. The program [1] required the development of a remotely operated system to fire a projectile at the high explosive (HE) sample.

The major component of the weapon system used for the tests was the universal receiver. This component has the advantage of being able to accommodate ballistic test barrels of all calibres up to and including the 0.50 calibre system selected for the main part of the program. The high velocity projectile used in the majority of the tests was a short flat-ended right cylinder which is ballistically unstable and yet was required to make normal impact with the test explosive target at a designated position. This was achieved by placing the charge 2m from the muzzle of the weapon and providing suitably sturdy blast and fragment baffling for the weapon platform. Even so, detonation of the explosive charge would expose personnel in the vicinity of the weapon to extremely high overpressure (e.g. an explosive charge of ½ kg could produce peak pressures greater than 120 kPa at the normal firing position). Furthermore, covered and confined explosive targets would produce high velocity lethal fragments over a large area. In order to protect the personnel conducting the experiments and allow on site examination of the components in the event of a misfire, a remotely operated firing system and a means of isolating the projectile from the target was required.

This report describes a system for the safe and remote operation of the weapon which can be readily adaptable to other small arms weapons. The system has been trialled in both field and laboratory environments and to this end a sample set of firing instructions is included as an appendix.

2. General Description of Set-up and System

The firing set-up consists of the weapon and two separate electrically operated systems, linked to each other so that they can be remotely controlled at a firing control panel (FCP) from a designated safe distance. Essentially these two systems are:-

- (i) an electrically actuated solenoid for the firing mechanism, and
- (ii) a linear actuator to block the line-of-fire of the projectile to the target with an interrupter plate

Blast protection for the weapon and firing system components was provided in the laboratory tests by the firing chamber walls and in the field trials by the strategic placement of large concrete blocks (Pendine blocks). Alignment of the barrel, projectile velocity measuring screens and the target was accomplished by fitting a small laser into a 0.50 calibre cartridge which was subsequently placed into the breech. The laser beam allowed accurate positioning of all components.

3. Safety Features

In previous experiments on percussion type explosive devices basic safety features such as manually operated lanyards for safety pin removal and drop weight triggerpulls were sufficient to ensure operator safety. In the projectile impact experiments, with the weapon system only 2 m from a large high explosive (HE) charge, this type of firing system could not be used. In the event of a misfire or drop-weight hang-up a hazardous situation would result with the weapon being in the cocked position and the projectile being in direct line of flight with the target HE. Using simple lanyards in this situation would require the unacceptable practice of manually reinserting the safety pin.

The system being reported overcomes these problems by both not allowing the projectile access to the target until the Firing Officer (FO) is ready to fire and isolating the target from the projectile in the event of a misfire. To accomplish this the system contains several safety features. The first of these is common to most experimental firings of electrically operated explosive devices; the use of a single Safety-Key without which the firing control panel can not be activated. This key is kept in the possession of the FO and is not inserted into the firing control panel until all trials personnel are safely under cover back at the firing point. The second feature is an electrically operated interrupter plate that can be placed in and removed from the line-of-fire between the projectile and HE target as required. The third is an electrically actuated solenoid, which fires the weapon, that is electronically linked to the interrupter plate so it cannot be actuated unless the interrupter plate is fully withdrawn. The fourth feature is the structuring of the blast and fragmentation shielding to protect both the weapon system, and its operators. As part of standard firing procedure the act of physically removing a safety pin (that will not permit the weapon to function) just prior to firing has long been considered good safety practice and is the final safety feature in the firing process.

A set of firing and operating instructions have been successfully implemented and have been included in the Appendix.

4. Component Description and Function

4.1 Solenoid Firing System

Figure 1 shows a cut-away drawing of the solenoid release mechanism with the manually operated safety pin in place through the release block. The cable from the drop-weight and release block is attached to the trigger of the universal receiver by a sturdy shackle. The major components are listed numerically in Table 1.

The pulling force required for the trigger mechanism was measured at 14 kg using a load-spring. A weight (5 kg) was selected such that after falling through a designated minimum distance (31 cm) it would have sufficient energy to overcome the trigger resistance and yet, if for some reason it had not cocked and released the trigger, after dropping would no longer have the potential energy to pull the trigger. With the weapon secured in its mount (see Figures 2, 3 and 4) the trigger is attached to the release block (#1 Figure 1) which is in turn coupled to the drop-weight (#2 Figure 1) by a 3 mm diameter steel cable (#4 Figure 1). The release block is held in position in a guide tube (#3 Figure 1) by a modified 12V car starter-motor solenoid actuator pin (#7 Figure 1). As a safety measure a manually operated lanyard (#10 Figure 1) attaches to the safety locking pin (#6 Figure 1). When pulled the safety pin impacts the pin restraint, emitting a noise audible at the firing point and the red flag drops to the ground (with the pin) when the lanyard is released.

The switching arrangement for the solenoid contains a Safety Key which is retained by the FO when performing the arming operations. Removal of the Safety Key from the firing control panel (see Figure 5) which is located under cover at the remote firing point location electrically isolates the solenoid energising circuit. When the arming procedure is completed and all personnel are under cover at the required safety distance (for our tests the safety distance was set at a minimum of 50 m for the field trials) the safety locking pin is manually removed using the lanyard and the Safety Key is inserted into the firing control panel and turned to the armed position. The solenoid is then electrically actuated by pushing the firing button which withdraws the solenoid pin from the release block allowing it and the weight to fall.

A 240V to 14V transformer was installed at the firing rig to overcome power loss, over lengthy cables, from the high current drain of the solenoid. This powers all the electronics at both locations.

4.2 Line-of-Fire Interrupter

The line-of-fire interrupter was incorporated into the system in order to take account of the following situations. Firstly, if a premature initiation of the weapon occurred while the weapon was being loaded the blast and/or high velocity fragments could prove

hazardous to the operator and secondly, manual inspection of the system would be required if a misfire of the weapon occurred.

The steel interrupter plate, coupled to a 12V linear actuator (model D.A.B.L.12-100), blocks the line-of-fire of the projectile to the high explosive target. When the FO is ready to fire, the actuator is remotely activated, from the firing point, to pull the interrupter plate clear. A red strobe light attached to the actuator and a red light on the firing control panel, labelled "BARRIER OPENING", flashes indicating that the barrier is being opened and warns of danger. The completion of withdrawal of the plate is signalled by a red light on the firing control panel, labelled "BARRIER FULLY OPEN". At any stage in the operation the "CLOSE BARRIER" button may be pressed (green light flashes) and the opening procedure will be cancelled and the barrier returned to the closed position. Likewise, during the closing procedure, the "OPEN BARRIER" button may be operated if required.

The gun can only be fired when, after removal of the safety pin, the following conditions are met:-

- (i) the "BARRIER FULLY OPEN" light is on
- (ii) the SAFETY KEY has been inserted into the firing control panel and turned to the armed position and
- (iii) the "FIRE" button is pressed.

Directly after the FIRE button has been pressed the "CLOSE BARRIER" light begins to flash and the linear actuator returns the interrupter plate to the closed position.

A circuit and wiring diagram for the linear actuator and its remote firing box connections are shown in Figures 6, 7, 8, and 9.

4.3 Blast Deflection

Firings were conducted both in the AMRL 2.25 kg firing chamber (see Figure 10) and at the Proof and Experimental Establishment, Graytown [P&EE(G)] Victoria. To protect the test assembly the target was placed on one side of a concrete block wall and the projectile was fired from the opposite side through an aperture, with the muzzle a minimum of 50 mm into the wall. When utilising the firing chambers this was accomplished by firing through one of the flash x-ray portholes from the instrumentation room. For blast and fragment protection at the field trial site a protective wall was constructed from large concrete (pendine) blocks, of dimensions 1.83 x 0.61 x 0.61 m (6' x 2' x 2'). Figure 11 shows a schematic of the set-up with the rectangular 100 x 600 mm steel tubing separator shown in position between the pendine blocks. Figure 12 shows the provision for the line-of-fire interrupter to be pushed down the steel tubing to separate the target from the path of the projectile. To stop the two sections of steel separator tubing from being pushed rearward and to the

left and right by the blast from the detonating target spacer plates were bolted to the separator frame at the front and rear joining the sections together (See Figure 12). Figure 13 shows the 50 Cal barrel in position with muzzle protruding approximately 10 cm inside a steel tubing aperture. Figures 2 and 3 show the field trial assembly with a further 4 pendine blocks positioned to shield the interrupter plate mechanism from the blast.

4.4 Barrel Alignment

To align the projectile path from the breech to the required impact point on the target a LP-2000 pen laser, class 3A, was modified to fit inside the cartridge case of a 50 calibre bullet. The beam of light was used to position the target and the velocity screen. The laser diode device is shown in Figure 14.

5. Lessons from Field Trials

5.1 Solenoid

In the initial field trials it was found that after 20 firings a liberal coating of fine dust caused the solenoid to malfunction. To overcome this problem on a temporary basis WD40 lubricant was sprayed onto the components before loading each shot. A more effective solution to the problem was the provision of a sturdy clear-plastic weatherproof shroud for both the firing rig and the weapon system fabricated with velco strip panels for ease of access. This can be seen in Figure 15 and has proven to be effective in protecting the equipment during both wet and dry conditions.

5.2 Linear Actuator

The motion of the linear actuator is halted at each extremity by the use of micro-switches. The microswitches used on the linear actuator are Burgess "V3S" which are specially designed for wet and dusty conditions. Earlier trials proved that less robust switches, not designed for all-weather conditions, were prone to malfunction. Also a rubber sealed cover was manufactured to encase the whole linear actuator assembly. This provided double protection from harsh environments. For ease of access for maintenance purposes the cover was attached with 15 mm wing nuts.

6. Instrument Options

The remotely operated firing system was found to be compatible with instrumentation used in the other tests. Projectile velocity measurements were taken with probes placed in front of the explosive target. Both break-lead [2] and optical fibre [3] techniques were successfully used to measure the velocity of the projectile. Time of arrival probes at the front and rear of the explosive target were used to determine where, inside the target explosive, the detonation reaction commenced.

Laboratory tests in the AMRL 2.25 kg chamber facility (Figure 10) enabled the use of multiple flash radiography (FXR) to study projectile orientation, impact and target response [1]. As an example, Figure 16 shows the 0.50 Cal projectile impacting a Composition B (cast with milled and boiled RDX) target at a velocity just below the 860 m/s critical velocity for the detonation threshold.

7. Conclusions

A remotely operated small arms firing system has been developed and successfully trialed for both field and laboratory use. The system contains effective safety measures and can be augmented by various forms of instrumentation to measure projectile velocities, target responses and impact effects.

The electronic linking of the solenoid and linear actuator systems allow the FO the choice to arm, disarm and fire from a designated safe distance from the ordnance being tested.

8. Acknowledgements

The authors would like to thank Lino Depaolo, Dean Howard, and Tim Bridges for their excellent work with the electronics, Mr George Jeffs for the frame design and drafting and also AMRL welder Rudi Pezzimenti.

The authors also record their thanks to members of the Weapons Systems Division and Ship Structures and Materials Division, in particular to Tim Bussell, Phil Box and Frank Marian, for helpful suggestions and advice.

9. References

1. Swinton, R.J. and Chick, M.C. Report in Publication "Projectile Impact of Australian Composition B". Maribyrnong, Vic. Aeronautical and Maritime Research Laboratory.
2. Bussell, T. "A Technique for the Measurement of Projectile Velocities using Graphite Leads". Report in publication.
3. Smith, G.E.. "Optical Break Fibre Velocity Measurements using Transmission and Reflectometer Techniques. File G6/4/8-4627. Report in Publication.

Appendix 1

Proposed Firing Instructions

1. General

- 1.1 The following firing instructions are issued for personnel involved in arming and firing the 0.50 calibre weapon. These shall be observed together with P&EE(G) range safety requirements. P&EE(G) is responsible for all range safety matters.
- 1.2 The 0.50 calibre weapon shall be fired using AMRL firing equipment. Arming and firing procedures shall only be undertaken by the Firing Officer.
- 1.3 The firing equipment has a Safety key which must be inserted into the Firing Control Unit (retained in an undercover position) before it can be energised.
- 1.4 Prior to arming the weapon the Firing Officer shall have performed firing equipment functioning tests at least once on each day of firing.

2. Steps Before Arming

- 2.1 The Firing Officer shall be in possession of the Safety Key.
- 2.2 All AMRL personnel not required for this operation shall then proceed to a safe area designated by the Firing Officer.
- 2.3 The Firing Officer and approved personnel shall proceed to Ground Zero (GZ).
- 2.4 The explosive target shall be positioned on sand bags.
- 2.5 The Scientist-in-Charge shall align the weapon with the Laser alignment device.
- 2.6 The Firing Officer shall activate the actuator enabling the barrier to block the line of fire of the 0.50 calibre weapon from the explosive target.
- 2.7 The Firing Officer shall connect the ends of the pull wire cable to the trigger of the 0.50 calibre weapon and the release block.
- 2.8 The Firing Officer shall attach the drop weight to the release block.

3. Steps To Arm

- 3.1 The Firing Officer shall position the release block and weight in the guide tube and secure it in place with the safety locking pin and solenoid release mechanism.
- 3.2 The Firing Officer shall insert the 0.50 calibre projectile into the breech and close the universal receptor.
- 3.3 The Firing Officer shall engage the trigger.

4. Steps Before Firing

- 4.1 The Firing Officer and remaining personnel shall proceed to the firing point.
- 4.2 The Firing Officer shall remove the safety locking pin by pulling the lanyard.
- 4.3 The Firing Officer shall confirm with the AMRL (OIC) that all instrumentation is ready.
- 4.4 The Firing Officer shall push the "OPEN BARRIER" button on the Firing Control Unit to remove the barrier from the line of fire. The "BARRIER FULLY OPEN" light indicates this has been achieved.
- 4.5 The Firing Officer shall arm the firing circuit by inserting the Safety Key and turning it to the armed position.

5. Firing

- 5.1 With the concurrence of Firing Officer the count-down shall begin after which the Firing Officer shall fire the round by pushing the fire button on the Firing Control Unit.

6. Steps After Firing

- 6.1 The Firing Officer shall remove the Safety Key from the firing unit and keep it in his possession.
- 6.2 The Firing Officer shall confirm the barrier to block the line of fire of the 0.50 calibre weapon from the explosive target, has returned to the "BARRIER FULLY CLOSED" position.
- 6.3 The Firing Officer shall proceed to GZ alone.
- 6.4 The Firing Officer shall disengage the trigger and remove the spent cartridge and ensure that the bore is clear.

6.5 The Firing Officer shall inspect the area and declare it safe.

6.6 The Firing Officer shall give the "ALL CLEAR" for personnel to break cover.

7. Disarming Instructions

7.1 The Firing Officer shall remove the Safety Key and keep it in his possession and disconnect the batteries.

7.2 The Firing Officer shall activate the actuator enabling the barrier to block the line of fire of the 0.50 calibre weapon from the explosive target.

7.3 The Firing Officer and approved personnel shall proceed to GZ.

7.4 The Firing Officer shall disconnect the lanyard from the locking pin and place the pin through the guide tube release block.

7.5 The Firing Officer shall disengage the trigger.

7.6 The Firing Officer shall open the universal receptor and remove the round using approved P&EE(G) procedures.

8. Steps To Be Taken In The Event Of A Misfire

8.1 The Firing Officer in conjunction with approved personnel shall ascertain whether the misfire was due to equipment malfunction or the round failing to fire.

8.2 If the misfire is a round failure, all personnel shall remain under cover for a period as directed by the P&EE(G) Firing Officer. After this period of time has elapsed the 0.50 calibre weapon shall be disarmed in accordance with the Disarming Instructions (section 7).

8.3 In the case of a misfire due to equipment failure, it may be necessary for P&EE(G) Firing Officer to break cover to rectify malfunctions in which case the 0.50 calibre weapon shall firstly be disarmed in accordance with the Disarming Instructions (section 7).



Figure 2: Test component assembled and ready for firing at field trial site.



Figure 3: Test component assembled and ready for firing at field trial site.

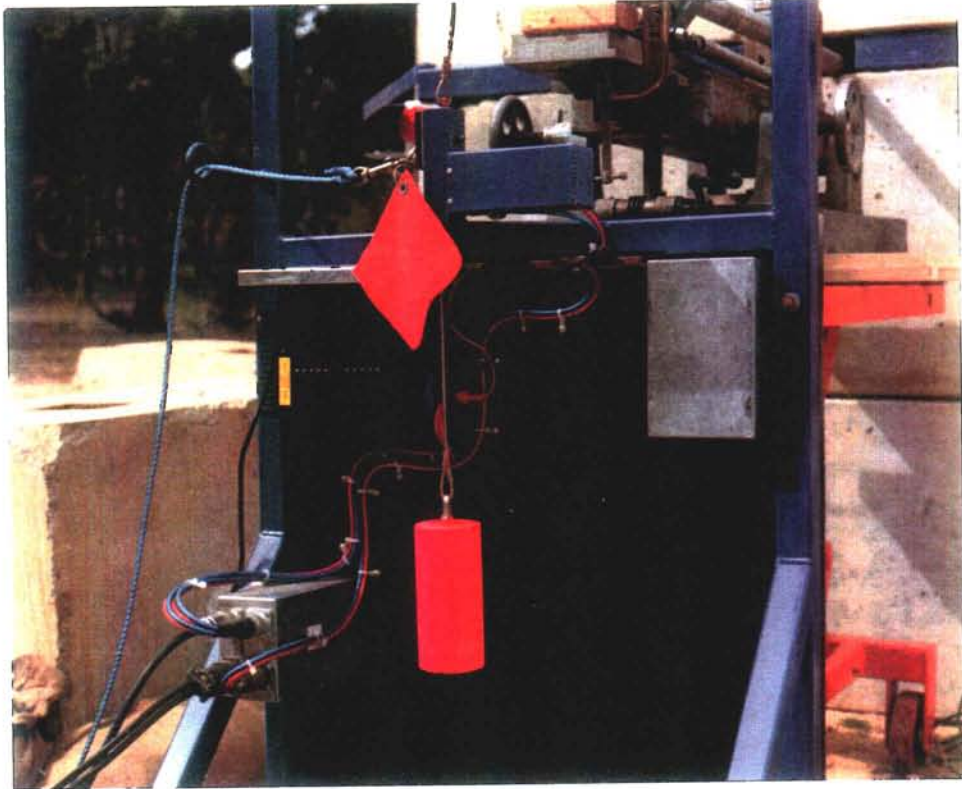

Figure 4: Solenoid drop-weight release mechanism with safety-pin lanyard attached.



Figure 5: Firing Control Panel with safety key inserted.

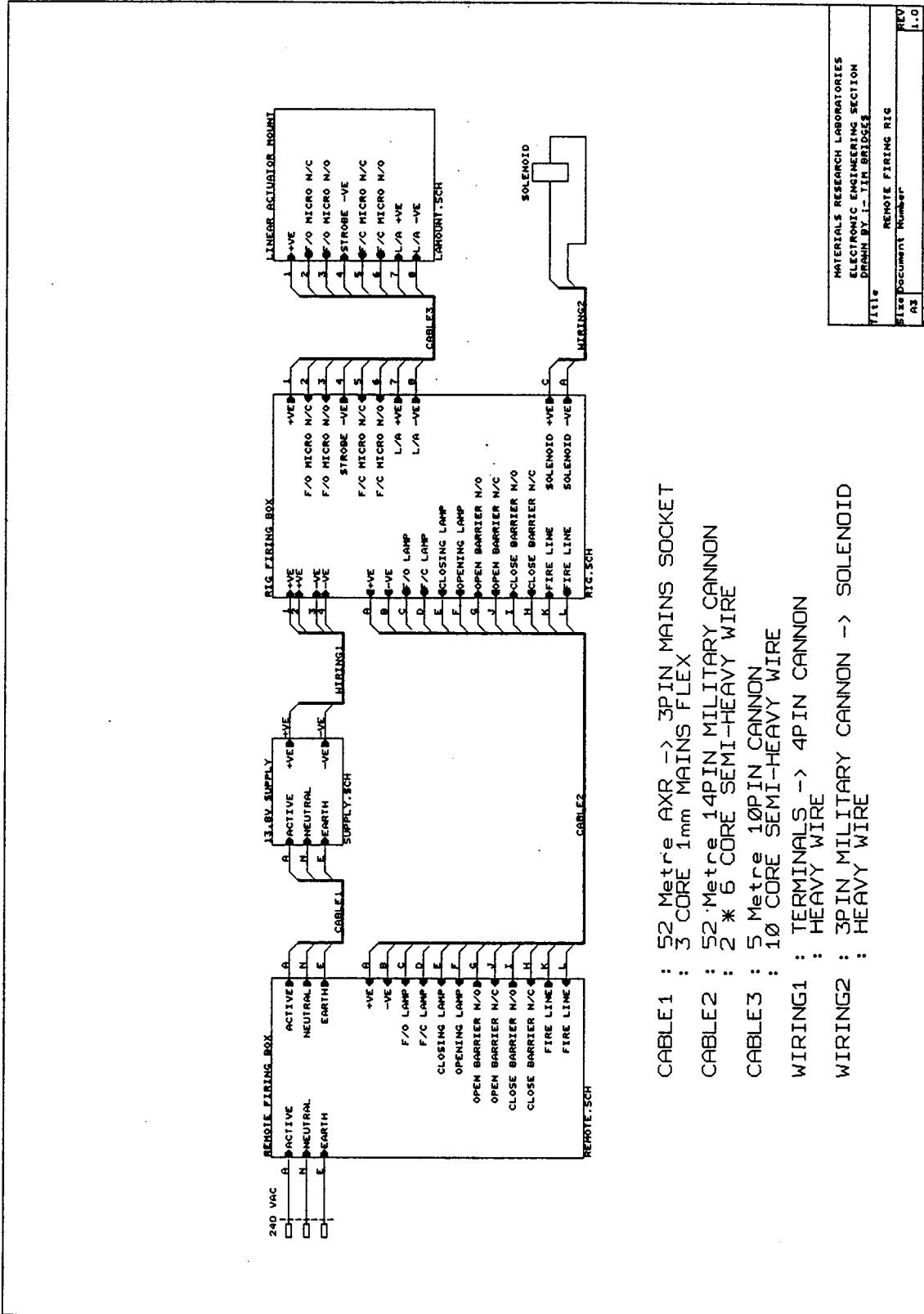

Figure 6: Circuit block wiring diagram for remote firing rig.

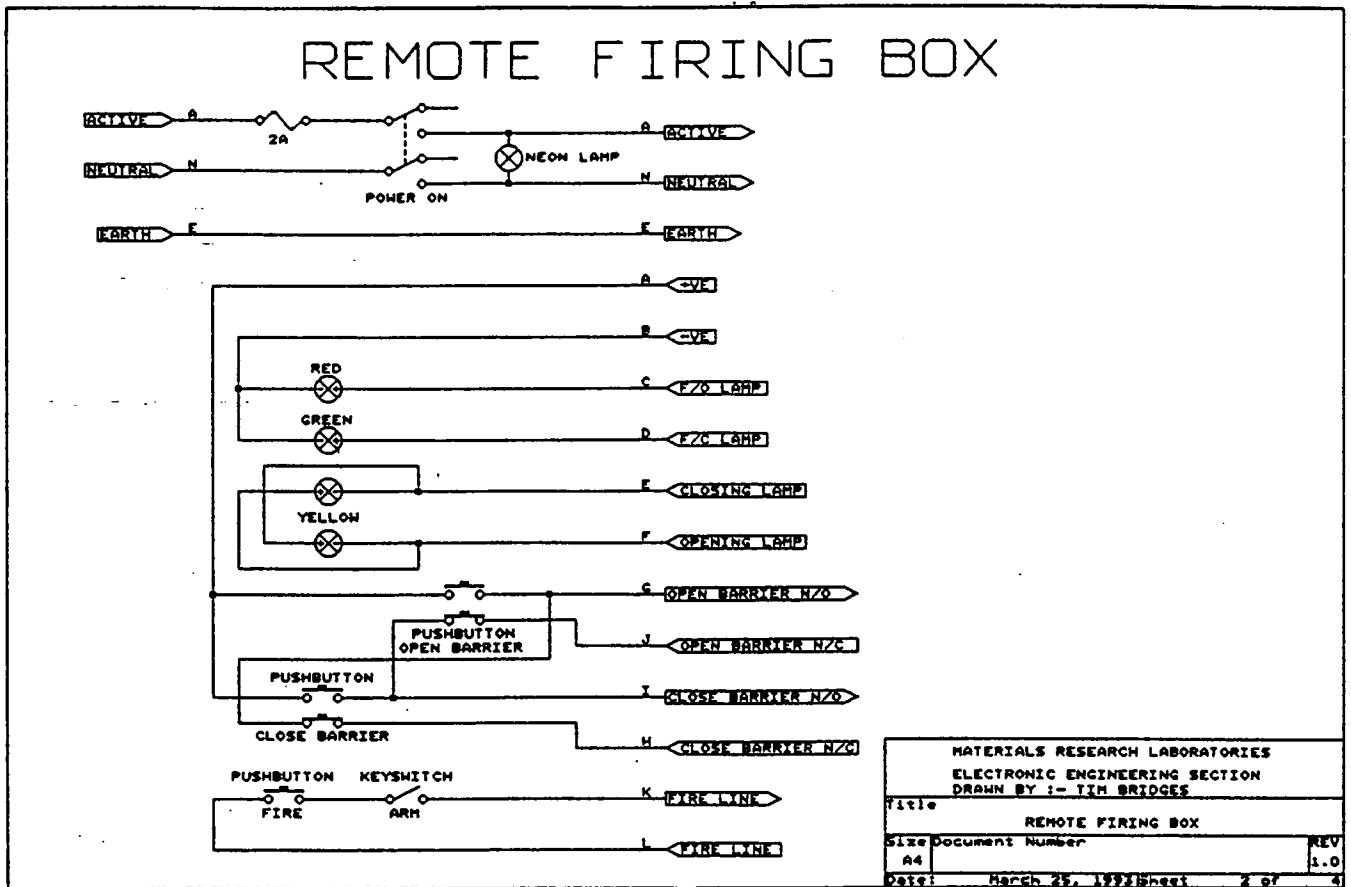

Figure 7: Circuit wiring diagram for firing control box.

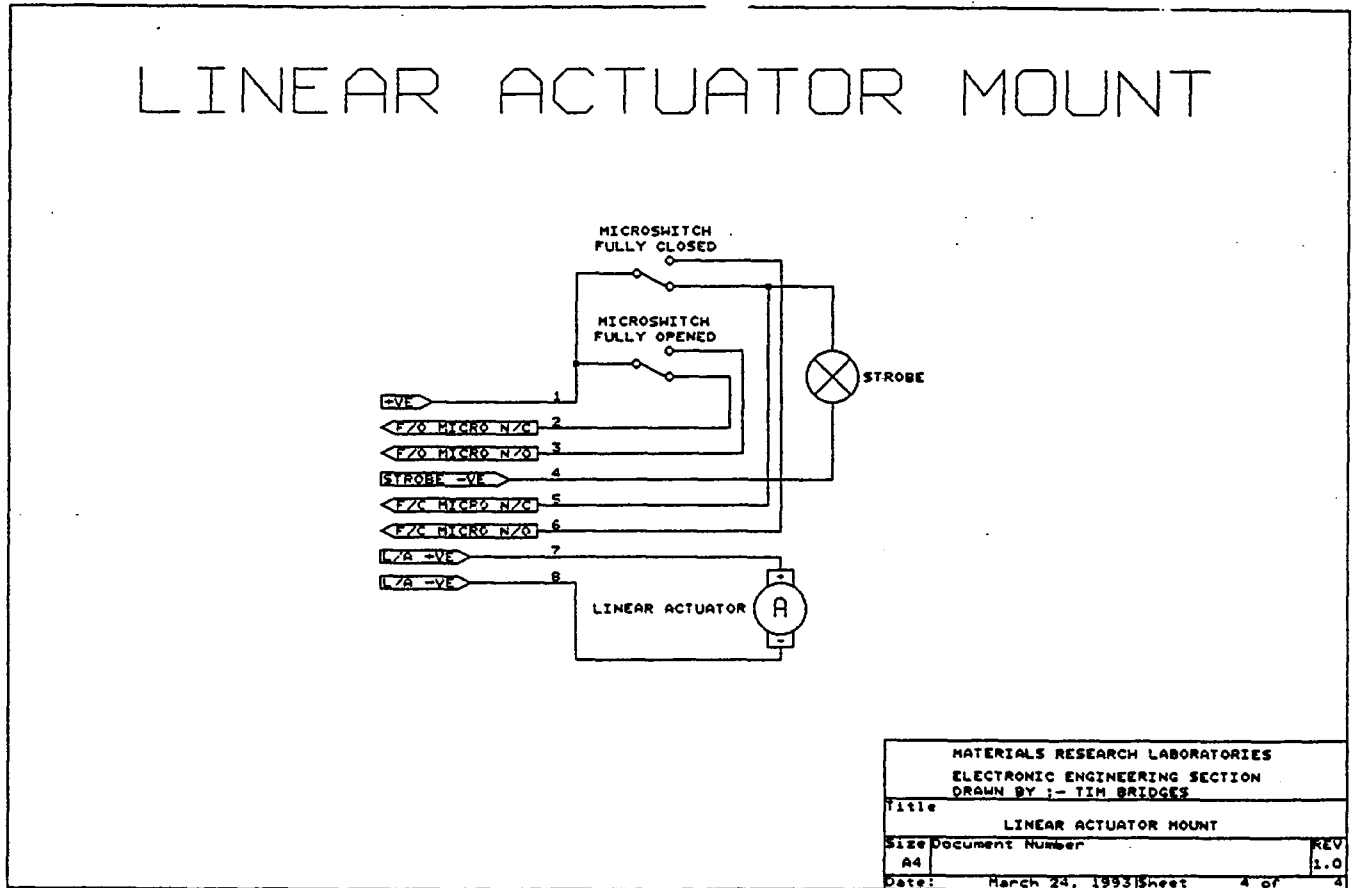

Figure 8: Circuit wiring diagram for linear actuator mount.

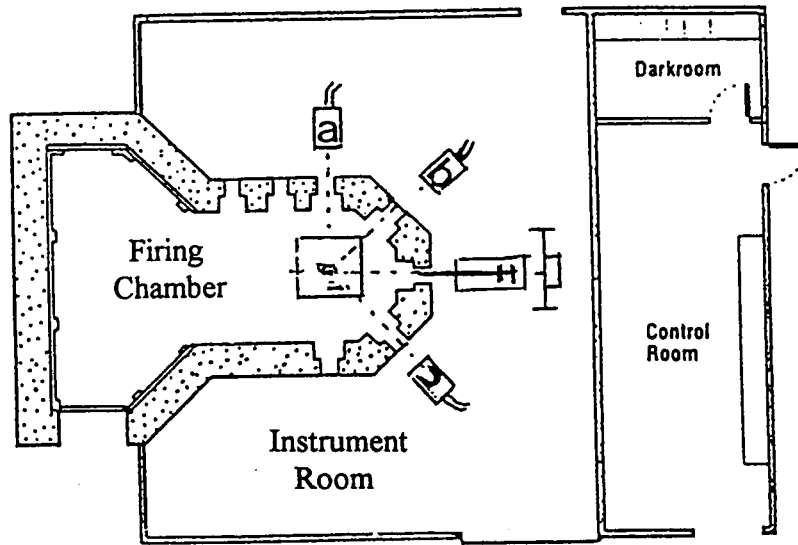

Figure 10(a) MRL 2.25 kg firing facility with flash x-ray head "a" being used orthogonal to line-of-fire at target in the chamber centre.

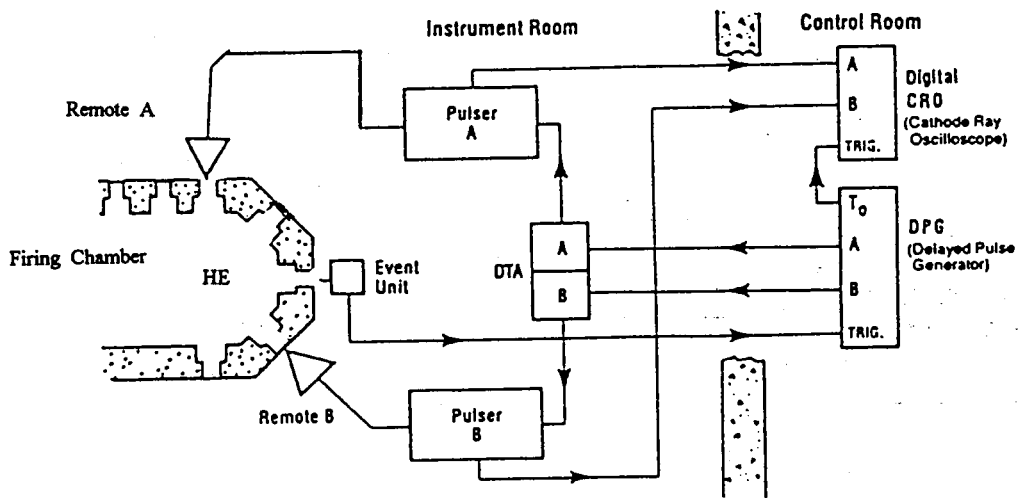

Figure 10(b): Firing circuit for synchronising projectile impact with trigger for flash x-ray unit "a".

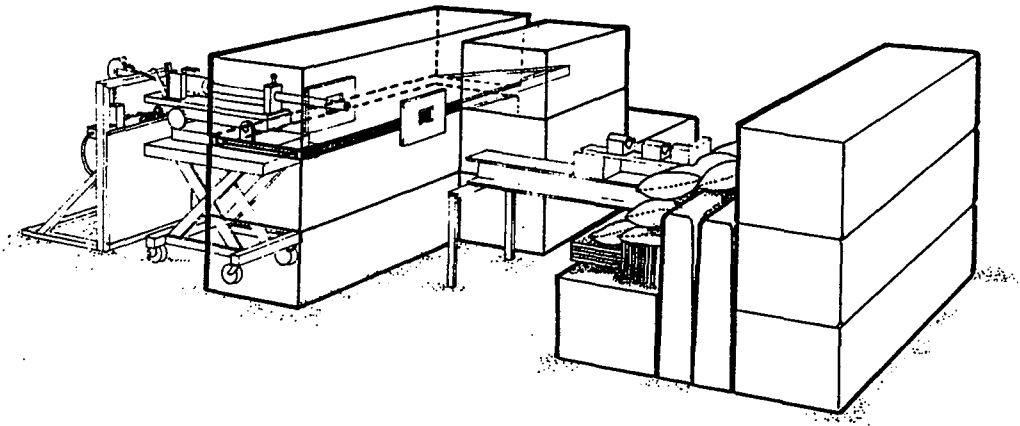

Figure 11: Schematic of blast and fragment protection provided by pendine block walls and sandbags at field trial site.

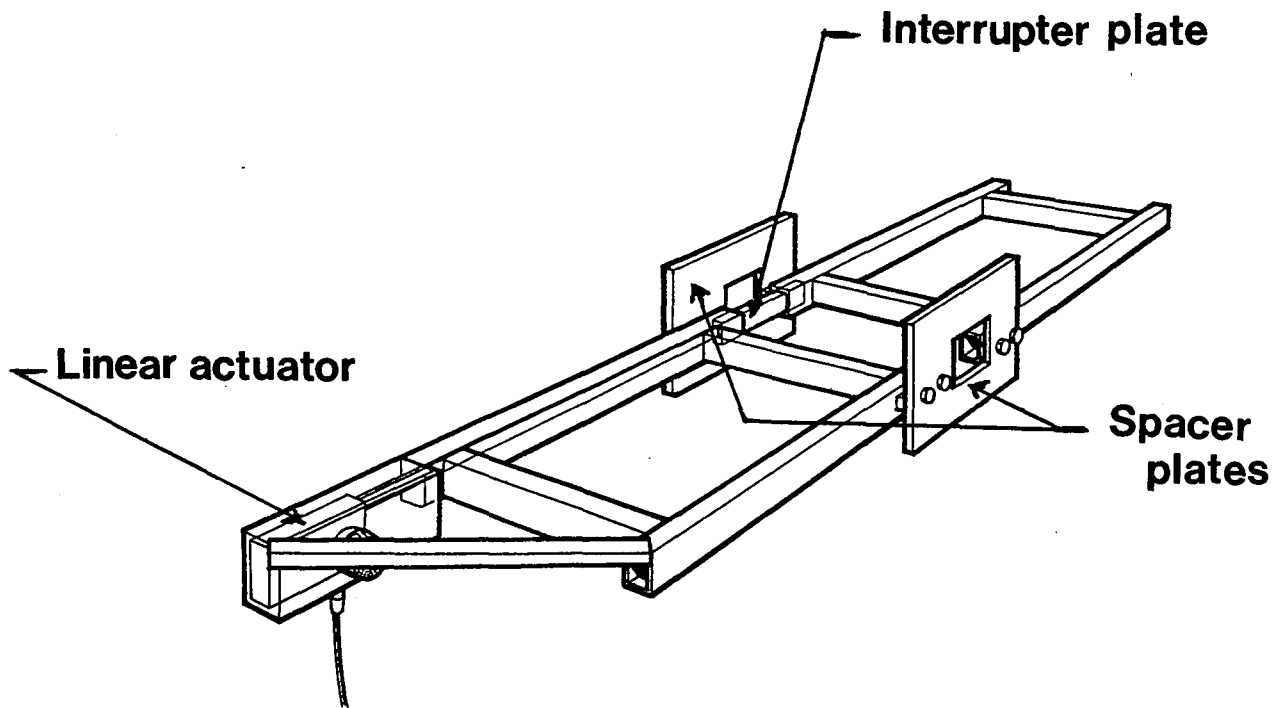

Figure 12: Schematic of steel tubing separator, with the linear actuator on the left which positions the steel line-of-fire interrupter plate.

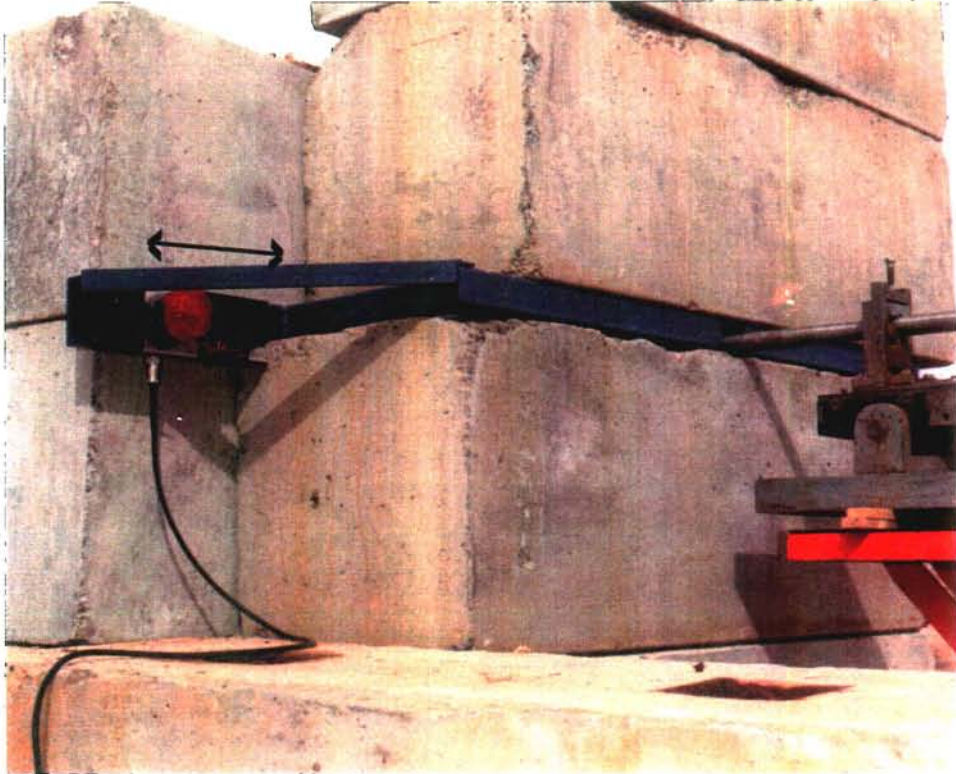

Figure 13: Steel tubing separator in position between pendine blocks at trial site. Interruptor plate (see Fig. 12) is pushed across line-of-projectile flight by the linear actuator, situated under red warning light.

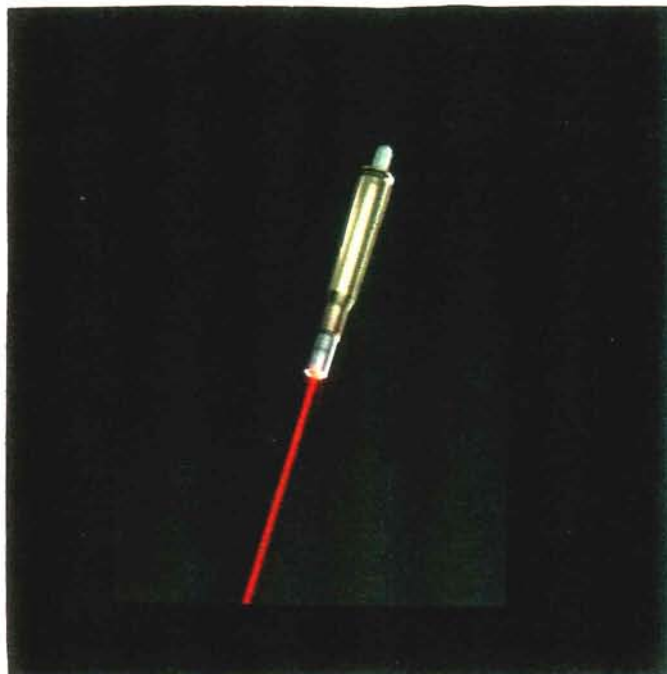

Figure 14: Laser used to align barrel with target.

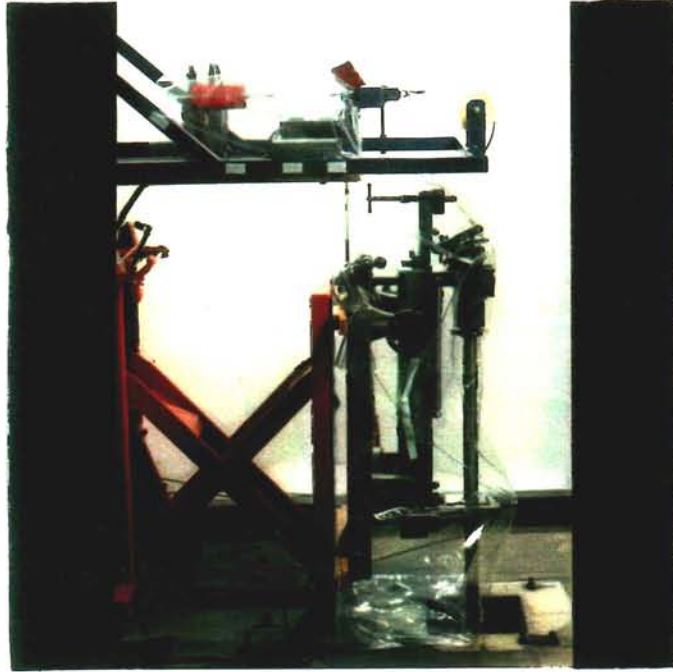

Figure 15: Weatherproof shrouds for protection from rain and dust at field-trial sites.

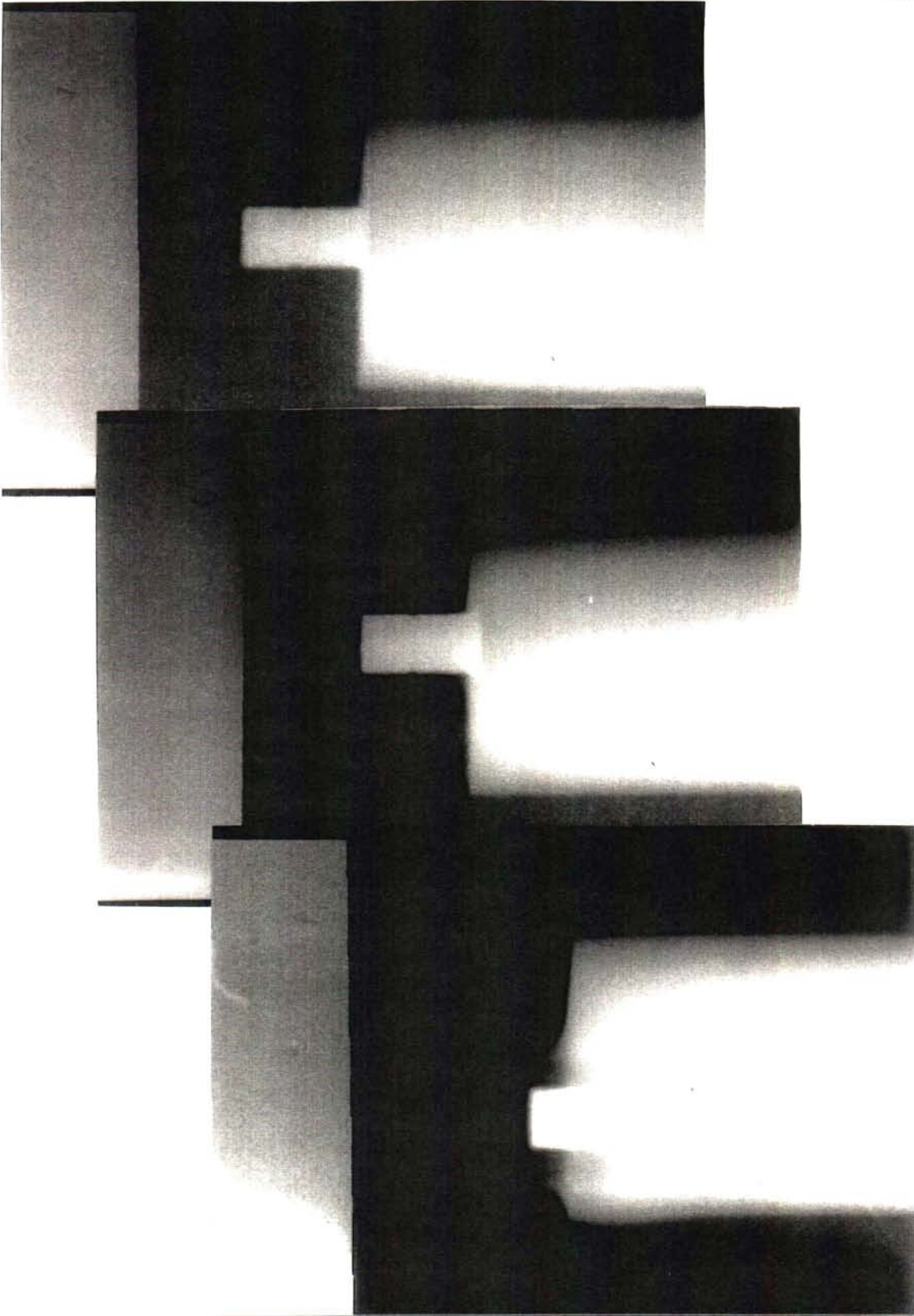

Figure 16: High speed flash radiographs of projectile impacting Comp B (milled and boiled RDX) target below the critical velocity for detonation of 860 m/s.

A Remotely Operated Firing System for Small Arms Weapons

R.J. Swinton and M. Vogl

(DSTO-TN-0005)

DISTRIBUTION LIST

Director, AMRL
Chief, Weapons Systems Division
Dr R.J. Spear
Dr B.W. Thorpe
Mr R.J. Swinton
Mr M. Vogl
Library, AMRL Maribyrnong
Library, AMRL Fishermens Bend

Chief Defence Scientist (for CDS, FASSP, ASSCM) 1 copy only
Head, Information Centre, Defence Intelligence Organisation
OIC Technical Reports Centre, Defence Central Library 8 copies
Officer in Charge, Document Exchange Centre
Air Force Scientific Adviser, Russell Offices 1 copy
Senior Defence Scientific Adviser / Scientific Adviser - Policy and Command
Senior Librarian, Main Library DSTOS
Librarian, DSD, Kingston ACT
Serials Section (M List), Deakin University Library, Deakin University, Geelong 3217
NAPOC QWG Engineer NBCD c/- DENGRS-A, HQ Engineer Centre, Liverpool
Military Area, NSW 2174 4 copies
ABCA, Russell Offices, Canberra ACT 2600
Librarian, Australian Defence Force Academy
Head of Staff, British Defence Research and Supply Staff (Australia)
NASA Senior Scientific Representative in Australia
INSPEC: Acquisitions Section Institution of Electrical Engineers
Head Librarian, Australian Nuclear Science and Technology Organisation
Senior Librarian, Hargrave Library, Monash University
Library - Exchange Desk, National Institute of Standards and Technology, US
Acquisition Unit (DSC-EO/GO), British Library, Boston Spa, Wetherby, Yorkshire LS23 7BQ, England
Library, Chemical Abstracts Reference Service
Engineering Societies Library, US
Documents Librarian, The Center for Research Libraries, US
Army Scientific Adviser, Russell Offices - data sheet only
Navy Scientific Adviser - data sheet only
Director General Force Development (Land) - data sheet only
ASSTASS PD, CP3-4-12, Campbell Park Offices, Canberra ACT - data sheet only
SO (Science), HQ 1 Division, Milpo, Enoggera, Qld 4057 - data sheet only
Librarian - AMRL Sydney - data sheet only
Counsellor, Defence Science, Embassy of Australia - data sheet only
Counsellor, Defence Science, Australian High Commission - data sheet only
Scientific Adviser to DSTC Malaysia, c/- Defence Adviser - data sheet only
Scientific Adviser to MRDC Thailand, c/- Defence Attache - data sheet only

P&EE Port Wakefield
HQ Log Command
ATEA
John Leach, WSD Salisbury

REPORT NO.
DSTO-TN-0005

AR NO.
AR-009-209

REPORT SECURITY CLASSIFICATION
UNCLASSIFIED

TITLE

A remotely operated firing system for small arms weapons

AUTHOR(S)
R.J. Swinton and M. Vogl

CORPORATE AUTHOR
DSTO Aeronautical and Maritime Research Laboratory
PO Box 4331
Melbourne Victoria 3001

REPORT DATE
July 1995

TASK NO.
DST 93/101

SPONSOR

FILE NO.
G6/4/8-4581

REFERENCES
3

PAGES
31

CLASSIFICATION/LIMITATION REVIEW DATE

CLASSIFICATION/RELEASE AUTHORITY
Chief, Weapons Systems Division

SECONDARY DISTRIBUTION

Approved for public release

ANNOUNCEMENT

Announcement of this report is unlimited

KEYWORDS

Remote firing
Solenoid

Linear actuator
Firing system explosives

Projectile impact
Equipment

ABSTRACT

A system and procedure is described for the remote firing of a 50 calibre weapon for firing projectiles into explosive samples only 2m away. The system can be used for laboratory or field firings and its major features are:

- (i) an electrically actuated solenoid firing mechanism and
- (ii) a linear actuator line-of-fire interrupter plate.

Field testing has demonstrated that the apparatus is safe and reliable. A set of firing and operating instructions have been successfully implemented and are included as an Appendix.