

**Behavioral Representation of Military Tactics for Single-Vehicle
Autonomous Rotorcraft via Statecharts**

by

Mark M. Hickie

B.S. Operations Research
United States Air Force Academy, 2003

SUBMITTED TO THE DEPARTMENT OF CIVIL AND ENVIRONMENTAL
ENGINEERING IN PARTIAL FULFILLMENT OF THE REQUIREMENTS FOR THE
DEGREE OF

MASTER OF SCIENCE IN TRANSPORTATION
AT THE
MASSACHUSETTS INSTITUTE OF TECHNOLOGY

JUNE 2005

© 2005 Mark M. Hickie. All rights reserved.

The author hereby grants to MIT permission to reproduce and to distribute publicly paper and
electronic copies of this thesis document in whole or in part.

Signature of Author: _____

Department of Civil and Environmental Engineering
April 28th, 2005

Certified by: _____

Mr. Mark L. Homer
Charles Stark Draper Laboratory Technical Supervisor
Thesis Supervisor

Certified by: _____

Dr. Brent D. Appleby
Lecturer in Aeronautics and Astronautics
Charles Stark Draper Laboratory Technical Supervisor
Thesis Advisor

Certified by: _____

Professor Cynthia Barnhart
Civil and Environmental Engineering and Engineering Systems
Thesis Reader

Accepted by: _____

Professor Andrew J. Whittle
Chairman, Departmental Committee on Graduate Students

Report Documentation Page

*Form Approved
OMB No. 0704-0188*

Public reporting burden for the collection of information is estimated to average 1 hour per response, including the time for reviewing instructions, searching existing data sources, gathering and maintaining the data needed, and completing and reviewing the collection of information. Send comments regarding this burden estimate or any other aspect of this collection of information, including suggestions for reducing this burden, to Washington Headquarters Services, Directorate for Information Operations and Reports, 1215 Jefferson Davis Highway, Suite 1204, Arlington VA 22202-4302. Respondents should be aware that notwithstanding any other provision of law, no person shall be subject to a penalty for failing to comply with a collection of information if it does not display a currently valid OMB control number.

1. REPORT DATE 00 JUN 2005	2. REPORT TYPE N/A	3. DATES COVERED -			
4. TITLE AND SUBTITLE Behavioral Representation of Military Tactics for Single-Vehicle Autonomous Rotorcraft via Statecharts		5a. CONTRACT NUMBER			
		5b. GRANT NUMBER			
		5c. PROGRAM ELEMENT NUMBER			
6. AUTHOR(S)		5d. PROJECT NUMBER			
		5e. TASK NUMBER			
		5f. WORK UNIT NUMBER			
7. PERFORMING ORGANIZATION NAME(S) AND ADDRESS(ES) Massachusetts Institute Of Technology		8. PERFORMING ORGANIZATION REPORT NUMBER			
9. SPONSORING/MONITORING AGENCY NAME(S) AND ADDRESS(ES)		10. SPONSOR/MONITOR'S ACRONYM(S)			
		11. SPONSOR/MONITOR'S REPORT NUMBER(S)			
12. DISTRIBUTION/AVAILABILITY STATEMENT Approved for public release, distribution unlimited					
13. SUPPLEMENTARY NOTES The original document contains color images.					
14. ABSTRACT					
15. SUBJECT TERMS					
16. SECURITY CLASSIFICATION OF:			17. LIMITATION OF ABSTRACT UU	18. NUMBER OF PAGES 115	19a. NAME OF RESPONSIBLE PERSON
a. REPORT unclassified	b. ABSTRACT unclassified	c. THIS PAGE unclassified			

[This Page Intentionally Left Blank]

Behavioral Representation of Military Tactics for Single-Vehicle Autonomous Rotorcraft via Statecharts

by

Mark M. Hickie

Submitted to the Department of Civil and Environmental Engineering on April 28th, 2005 in
Partial Fulfillment of the Requirements for the Degree of
Master of Science in Transportation

ABSTRACT

Over the past several years, aerospace companies have developed unmanned helicopters suitable for integration into military operations as reconnaissance platforms. These rotorcraft, however, require ground-based human controllers varying in number based on the size and complexity of the system controlled. The automation these platforms have achieved is limited to takeoffs, landings and navigation of pre-programmed waypoints. The possibilities for further development then are vast; with growing sensor and communication capabilities, there exists potential for unmanned rotorcraft to execute the full range of aviation missions normally reserved for manned assets. However, before military planners use autonomous helicopters as robust force multipliers, research must attempt to quantify possible tactics for software architecture implementation.

This paper presents a methodology for developing autonomous helicopter tactics through the review of current military doctrine, pilot interviews, and simulation testing. Several tactics suitable for unmanned helicopters are recommended with an attempt to quantify the described behaviors using statecharts. The tactics diagrammed in the statecharts, or visual models that outline transitions between states based on conditions being met or events having occurred, are tested for feasibility in scenarios constructed with a US Army simulation tool, One Semi-Automated Forces (OneSAF) Testbed Baseline 2.0 (OTB 2.0). The ensuing results point to the success of using a thorough methodology to develop autonomous tactics and using statecharts to transfer qualitative behaviors into quantifiable actions.

Thesis Supervisor: Mark Homer

Title: Senior Member of the Technical Staff

Thesis Reader: Cynthia Barnhart

Title: Professor, Civil and Environmental Engineering and Engineering Systems

Thesis Advisor: Brent Appleby

Title: Lecturer in Aeronautics and Astronautics

[This Page Intentionally Left Blank]

ACKNOWLEDGEMENTS

First and foremost, I would like to thank Mark Homer, my principal advisor over the past two years at Draper Laboratory. His enthusiastic support of my research has been pivotal in helping me execute this project, and his insightful mentoring has allowed me to take away much more than just research feedback from our meetings. I leave MIT a better person because of his influence on me.

In addition, I owe a special debt of gratitude to Brent Appleby and Cindy Barnhart for their help. I thoroughly appreciate the support that each of them gave, and I thank them both for enthusiastically donating their time and energy to this thesis.

I would also like to thank the Education Office at Draper Laboratory, the Center for Transportation and Logistics at MIT, and the United States Air Force for affording me the opportunity to study and learn these past two years. I cannot express enough appreciation to these groups for enabling graduate students to learn at both a world-class university and research laboratory. Additional thanks go to Lt Col Andrew Armacost at the United States Air Force Academy and Dr. Steve Kolitz at Draper Laboratory for their much-appreciated efforts in helping me secure this assignment.

In researching this thesis, I owe many thanks to a large group of people: Larry Mercillott for working with me to make my research at Fort Rucker educational, informative, and enjoyable; CW4 Mike Wells, CW4 Terry Gibson, Captain Kevin Myers, Captain Tyler Smith and Major Mike Odom for patiently and insightfully answering all my pilot questions (with a special thanks to Captain Myers and Major Odom for entertaining my additional pestering), and to Thomas Akin, Michael Halsey, and Jim Delashaw at Fort Rucker for their invaluable assistance.

In addition, I owe a special thanks to Joel Tleon for his generosity in aiding my thesis and to Janet O'May, Ted Tafoni, MaryAnn Matyola and Joseph Brian Kelly for providing exceptional, gratis support with OneSAF. A special thanks goes to Janet who warmly fielded many, many questions over the phone.

To my friends at Draper, MIT, the University of Maryland and elsewhere, thank you for all the great memories. I wish I could list all the names I should, but know that if you are reading this, you are probably one of the people I would have liked to thank.

Finally, thank you to my brothers for the hour at the lake and to my parents for their continued love and guidance. I could not have made it to this point in my life without your unwavering support.

The thesis was prepared at The Charles Stark Draper Laboratory, Inc. under Internal Company Sponsored Research Project 18073, GC DLF Support.

Publication of this thesis does not constitute approval by Draper or the sponsoring agency of the findings or conclusions contained therein. It is published for the exchange and stimulation of ideas.

The views expressed in this thesis are those of the author and do not reflect the official policy or position of the United States Air Force, Department of Defense, or The U.S. Government.

Mark M. Hickie, 2d Lt, USAF Date

ASSIGNMENT

Draper Laboratory Report Number T-1507

In consideration for the research opportunity and permission to prepare my thesis by and at The Charles Stark Draper Laboratory, Inc., I hereby assign my copyright of the thesis to The Charles Stark Draper Laboratory, Inc., Cambridge, Massachusetts.

Mark M. Hickie, 2d Lt, USAF Date

TABLE OF CONTENTS

CHAPTER 1 INTRODUCTION	13
1.1 PROBLEM STATEMENT	14
1.2 OBJECTIVES.....	15
1.3 OVERVIEW	15
CHAPTER 2 BACKGROUND.....	17
2.1 CURRENT UAV TACTICS AND MISSIONS.....	17
2.2 AUTONOMOUS UAV DEVELOPMENT.....	19
2.2.1 DARPA UCAR Program.....	19
2.2.2 J-UCAS.....	20
2.3 AUTONOMOUS HIERARCHICAL PLANNING LEVELS	22
2.4 TACTICS DEVELOPMENT RESEARCH	25
CHAPTER 3 DESIGN AND METHODOLOGY	29
3.1 THE CONVERGING SPIRAL.....	30
3.2 FIELD MANUAL RESEARCH	31
3.3 SUBJECT MATTER EXPERT INTERVIEWS.....	32
3.4 STATECHARTS	33
3.5 SIMULATION.....	43
CHAPTER 4 SINGLE-VEHICLE AUTONOMOUS ROTORCRAFT TACTICS	49
4.1 RUNNING FIRE ATTACK	49
4.2 POPUP FIRE / HOVERING ATTACK	59
4.3 MANNED/UNMANNED LAZING	68
4.4 FORWARD TETHER	77
4.5 COMMUNICATIONS RELAY	86

4.6	SCREENING/SECURITY.....	95
CHAPTER 5 SUMMARY AND FUTURE WORK		108
5.1	THESIS SUMMARY	108
5.2	FUTURE WORK.....	109
APPENDIX A: GLOSSARY OF TERMS.....		112
REFERENCES.....		113

LIST OF FIGURES

Figure 2.1: Various UAV Systems and Specifications ^[58]	18
Figure 2.2: Visualization of UCAR concept ^[33]	20
Figure 2.3: J-UCAS UCAV Prototypes ^[31]	21
Figure 2.4: Networked Engagement of UCAV Aerial Vehicles ^[30]	22
Figure 2.5: Hierarchical Planning of Autonomous Vehicles ^[62]	23
Figure 2.6: Event Graph of UAVSim ^[23]	27
Figure 3.1: The Converging Spiral of Autonomous Rotorcraft Tactics Development.....	30
Figure 3.2: High-Level Wristwatch Statechart ^[17]	35
Figure 3.3: The Statechart “Equation” ^[17]	35
Figure 3.4: State Transition Diagram ^[17]	36
Figure 3.5: Statechart Representation ^[17]	37
Figure 3.6: Statechart Depth Hidden in State D ^[17]	37
Figure 3.7: Statechart Orthogonality and Broadcast Communicability ^[17]	38
Figure 3.8: Orthogonality in State Diagrams ^[17]	39
Figure 3.9: State D ^[17]	40
Figure 3.10: Integration Team Statechart ^[17]	41
Figure 3.11: State Transition Diagram ^[17]	41
Figure 4.1: Diving Fire ^[21]	50
Figure 4.2: Statechart for Running Fire Tactic	52
Figure 4.3: SA-8 SAM Launcher.....	55
Figure 4.4: Running Fire Screenshot	56
Figure 4.5: Popup Attack	59

Figure 4.6: Rotor Wash Effects over Water.....	60
Figure 4.7: Hovering Fire Statechart	63
Figure 4.8: Popup Fire Tactic Screenshot.....	65
Figure 4.9: Maximum Designator Angle ^[21]	69
Figure 4.10: Laser Designator Safety Zone ^[21]	70
Figure 4.11: Unmanned Laser Designator Statechart.....	72
Figure 4.12: Laser Designator Screenshot	74
Figure 4.13: Forward Tether Statechart	79
Figure 4.14: Flight Altitude Definitions ^[20]	80
Figure 4.15: Forward Tether Tactic Display.....	82
Figure 4.16: Communication Relay Statechart.....	88
Figure 4.17: Communication Relay Baseline Tactic	90
Figure 4.18: Communication Relay Autonomous Tactic	91
Figure 4.19: Screen Operations ^[20]	96
Figure 4.20: Capable Execution of FM 1-114 Critical Tasks ^[58]	97
Figure 4.21: Screening Statechart.....	99
Figure 4.22: Bounding Overwatch Flank Screen ^[20]	101
Figure 4.23: Security Baseline with Bounding Overwatch	102
Figure 4.24: UAR Security Tactic in Engagement.....	103
Figure 5.1: Running Fire Attack System	110

LIST OF TABLES

Table 1: UCAR Vehicle Specifications ^[8]	46
Table 2: AH-64 Day Engagement Evaluation Table ^[21]	54
Table 3: Running Fire Baseline Results.....	57
Table 4: Running Fire Tactical Results	57
Table 5: Popup Baseline Results.....	66
Table 6: Popup Tactical Results	66
Table 7: Laser Designator Baseline Results	75
Table 8: Manned/Unmanned Lazing Tactic Results.....	76
Table 9: Forward Tether Baseline Results.....	83
Table 10: Forward Tether Tactic Results.....	84
Table 11: Communication Relay Baseline Results.....	92
Table 12: Communication Relay Tactic Results	93
Table 13: Screening Baseline Results.....	104
Table 14: Screening Tactical Results.....	105

[This Page Intentionally Left Blank]

Chapter 1 Introduction

The development and use of Unmanned Aerial Vehicles (UAVs) has increasingly been at the forefront of aeronautical research efforts. In 2003, UAV development accounted for approximately 10% of all military aircraft funding. As a foreteller to the military's growing acceptance and reliance on these pilot-less systems, in 2010 this number is projected to increase to 30% [25]. Furthermore, one group of researchers that monitors the burgeoning development of UAVs estimates that over 40 United States companies or research institutions are flying at least one unmanned vehicle [63]. Out of these 40 companies, there are approximately 115 different working prototypes, although not all of these UAVs are designed specifically for military purposes. Nevertheless, the military has been the dominant customer for UAV procurement to date, and the majority of systems being fielded envision the services as the expected customers.

With forecasts of increased funding and large numbers of UAVs being developed, the future of military aviation, it can be argued, is moving towards unmanned assets. Several analysts that watch the defense industry consider the F-35, or the Joint Strike Fighter, to be the last manned fighter aircraft ever to be built. In addition, several Department of Defense projects have sought or are seeking to use unmanned vehicles in ways once considered impossible for machines; the Joint Unmanned Combat Aerial System (J-UCAS) performing suppression of enemy air defense (SEAD) is an example of this. This gradual paradigm shift from the predominant use of manned assets to unmanned assets, while underway, may still take several years to complete. In addition, it may not be the last shift in how aircraft are controlled in the skies.

As each armed service replaces manned systems with unmanned ones, there is also a gradual shift towards building more autonomy into UAVs and for good reasons [27]. The first is that a high level of autonomy enables vehicles to reduce communication with a ground controller, and thus minimize the bandwidth consumed by the operation. Correspondingly, in such situations where communications have been lost, whether due to jamming or line of sight being broken, autonomy enables the vehicle to continue operating under pre-arranged plans. Finally, autonomy in vehicles can enable a force multiplier effect. Currently, several operators are required to fly both a single Predator and Global Hawk UAV; autonomous collaboration could alter this and thus enable a *single* ground operator to control *multiple* UAVs.

Already in aviation, automation has changed tactics and enabled more efficiency and effectiveness in wars. As an example, in the Vietnam conflict, fighter pilots performing bombing runs were forced to calculate and fly precise low-level routes to ensure bombs landed on their targets; as a contrast, pilots can now use Precision Guided Munitions (PGMs) to accurately engage a target from thousands of feet in the sky. This "release and forget" capability for pilots is just one example of technology significantly altering warfare tactics. With UAVs, autonomy could similarly change the tactics US forces employ just as PGMs have changed those performed by pilots.

1.1 Problem Statement

The shift towards using UAVs in military operations is with merit considering their additional capabilities; compared to manned assets, they present many significant advantages. UAVs can loiter over an engagement area for many more hours than a human-piloted plane can. Unmanned vehicles can perform significantly more dangerous missions without fear of being shot down affecting their performance. Finally, with the removal of the pilot, the flight characteristics of a UAV can be far more aggressive due to an increased ability to handle accelerations. Although these points represent just a few benefits of unmanned vehicles, their distinct capabilities have enabled a broadening vision of their possible employment in conflicts.

As UAVs have been included in each of the services, the missions unmanned vehicles are executing have been growing. The military has traditionally used these vehicles to perform tasks such as reconnaissance and surveillance. However, UAV missions have also included target practice, communication relays, and electronic intelligence collectors. Most recently, an offensive mission was added to the list; while in support of Operation Enduring Freedom in Afghanistan, the Predator UAV successfully destroyed an enemy target by launching a Hellfire missile [47].

The tasks UAVs are considered capable of performing are growing, however, with this growth a fundamental problem arises. Once an unmanned vehicle has been deemed capable to perform a mission, the question then becomes, “How do we employ the UAV in execution of the assignment?” Specifically, “What are the tactics and behaviors that the unmanned vehicle should perform as it accomplishes its mission?”

In the past, this question has been easily answered. With a Predator launching a Hellfire missile, the vehicle is remote controlled thus making solving the tactical usage of the vehicle quite simple; the pilot of the vehicle uses his own techniques to manually fly the aircraft and make the strike. The decision, in that case, of how the vehicle behaves is simple; the pilot single-handedly makes a choice and executes the mission as best he or she sees fit. If strike UAVs remain remote piloted, the tactics they employ are determined in real-time via the techniques performed by the pilot operator.

Yet with unmanned vehicles being designed to incorporate more autonomy into their performance, this approach is no longer valid. Specifically, the tactics an autonomous vehicle employs must be researched and agreed upon *before* inclusion into the UAV’s performance design. Determining these tactics, though, becomes difficult as the real-time decision making inherent in a trained pilot may not be available.

The problems in pre-determining autonomous tactics could be considered numerous, yet can be broken down into three fundamental challenges. The first is that tactics employed by the military are constantly changing; a myriad of shifting factors influence a unit’s behavior. The second is that autonomous tactics must be based on sound doctrine; it is entirely infeasible to expect an autonomous vehicle to defy not only conventional constraints such as gravity but also each branch’s expected employment of the vehicle. Finally, the third problem is that groups must work together to program an autonomous tactic; the luxury of a single pilot deciding the vehicle’s employment does not exist. As various groups must communicate and agree on a vehicle’s behavior, it is imperative that designers, programmers, and users easily understand the tactic to allow for inputs and feedback from multiple communities.

Based on these challenges and a growing need to analyze the role of autonomy in a vehicle's behavior, this thesis explores single-vehicle tactics for a generic military helicopter. Specifically, this thesis seeks to answer, "What is a sufficient methodology for researching and developing autonomous military tactics in single-vehicle rotorcraft that is soundly based on doctrine, easily communicable between communities, incorporates the dynamics of modern warfare, and insures an acceptable level of mission performance?" The decision to explore rotary wing airframes, as opposed to fix-winged aircraft, spun out of initial research into the Unmanned Combat Armed Rotorcraft (UCAR) program explained in Chapter 2. The methodology of developing autonomous rotorcraft tactics, however, could also readily apply to fixed wing airframes.

1.2 Objectives

The main contribution of this thesis is to outline, describe, and test a methodology for developing autonomous tactics for single vehicle rotorcraft. The methodology employed uses Army field manuals, interviews with subject matter experts and a simulation tool to ultimately develop six tactics for a single Unmanned Autonomous Rotorcraft (UAR). These tactics, found after following an iterative design process, are represented in a visual form for computer programming known as a statechart. The specifics of each step in the methodology, and a full description of statechart representation are enumerated in Chapter 3.

The six tactics presented in this thesis recommend just a few possible ways for an autonomous agent to behave in the execution of possible missions. To this end, the simulation results are not certifiable proof that the tactics presented are the *only* behavior for an autonomous vehicle to perform. In order to make this claim, testing is necessary with classified or confidential parameters in a simulation nearly 100% accurate to the performance of an autonomous vehicle and its possible enemies. Nevertheless, this thesis does propose and test a methodology that tackles a very real problem with the evolving development of autonomy in UAVs. The six tactics developed for helicopters represent possible behaviors and can be considered a feasible foundation for further research and testing. While not the central reason for this research, the tactics are an auxiliary benefit of work performed; the proposed objective and crux of this thesis still remains to evaluate a methodology that enables automation of single-vehicle helicopter tactics.

1.3 Overview

The outline of this thesis is as follows: Chapter 2 will present a background on current UAVs and their tactical employment before discussing the inclusion of autonomy into UAV operations as seen in two major programs. The chapter then provides a hierarchical definition of how this thesis classifies tactics before concluding with overviews of other studies that has sought to advance tactics research. Chapter 3 provides an in-depth analysis of the methodology utilized in this thesis by covering the three-pronged, converging spiral approach while Chapter 4 outlines each of the six tactics developed by discussing background, statechart layout, simulation results, and analysis of each tactic. Chapter 5 summarizes the information presented over the course of the thesis and proposes areas of future work.

[This Page Intentionally Left Blank]

Chapter 2 Background

In this chapter we lay some of the foundation needed for developing autonomous rotorcraft tactics and their representation via statecharts. We start by giving a brief history of UAV development and then outline the predominant platforms in use today. Afterwards we tackle the current missions and tactics performed by UAVs before discussing projects designed to incorporate autonomy into unmanned vehicles. We then provide our definition of the word “tactics” in the hierarchy of autonomous planning and finally conclude with a brief summation of other methodologies used to research, outline and develop tactics.

2.1 Current UAV Tactics and Missions

The military has only effectively employed UAVs in the past several decades although their use has been around since the Civil War [14]. During this conflict, both Union and Confederate forces sent out balloons laden with explosives with hopes they would land in the enemy’s ammunition depot; this effort largely failed. Japanese forces tried a similar experiment in the Second World War. In also using balloons, the Japanese attempted to float their “UAVs” loaded with incendiary devices across the Pacific Ocean. They hoped their attack balloons would be carried aloft by the winds until falling upon American forests and igniting forest fires. However, this attempt was largely unsuccessful as the Japanese could not assess the results of their efforts, and this early autonomous attack tactic was also abandoned.

Effective use of UAVs, though, did happen in the Vietnam War through the use of drone aircraft. In that conflict, the military used smaller sized aircraft in photo reconnaissance, electronic intelligence, and surface-to-air missile detection. These Firebee UAVs flew over 3,400 sorties in the war and paved the way for future UAV usage, in particular by the Marines and the Navy with the fielding of the Pioneer UAV. The Pioneer is a fixed wing, short range, propeller driven UAV that started operations in 1985 and saw action in the Persian Gulf War as a forward located spotter for naval gunfire [44]. The Pioneer’s success in this conflict prompted military planners to invest more heavily in this new capability, and to date one of their biggest payoffs has been the Air Force and CIA’s multi-faceted Predator UAV. This medium range reconnaissance and acquisition platform was first used in the Balkans conflict and now widely sees employment in Iraq and Afghanistan. However, the Pioneer and the Predator are not the only UAV systems currently employed in the Department of Defense; Figure 2.1 summarizes a few other predominant UAVs, their specifications, and more importantly the missions they carry out.

<u>UAV SYSTEM</u>	<u>RANGE</u>	<u>MAX SPEED</u>	<u>ENDURANCE</u>	<u>PAYLOAD</u>	<u>NAVIGATION</u>	<u>MISSION</u>
DRAGON WARRIOR	100 NMs	135 KNOTS	2.5 HOURS	EO/IR	PREPROGRAMMING/ AUTONOMOUS	RECONNAISSANCE
DRAGON EYE	10 KMs	35 KNOTS	1 HOUR	EO/IR	PREPROGRAMMING/ AUTONOMOUS	RECONNAISSANCE
FIRE SCOUT	110 NMs	125 KNOTS	6 HOURS	EO/IR/LRFD/ SAR/MTI	AUTONOMOUS	RECONNAISSANCE/ TARGET AQC
PREDATOR	500 NMs	130 KNOTS	>20 HOURS	EO/IR/SAR	REMOTE PILOT CONTROL	RECONNAISSANCE/ SURVEILLANCE/ TARGET AQC
GLOBAL HAWK	3,000 NMs	345 KNOTS	>40 HOURS	EO/IR/SAR/ MTI	PREPROGRAMMING/ AUTONOMOUS/ REMOTE PILOT CONTROL	RECONNAISSANCE
HUNTER	200 KMs	106 KNOTS	12 HOURS	EO/IR	REMOTE PILOT CONTROL	RECONNAISSANCE/ SURVEILLANCE/ TARGET AQC
SHADOW 200	200 KMs	150 KNOTS	6-8 HOURS	EO/IR/C2	PREPROGRAMMING/ AUTONOMOUS/ REMOTE PILOT CONTROL	RECONNAISSANCE/ SURVEILLANCE/ TARGET AQC

Figure 2.1: Various UAV Systems and Specifications ^[58]

In analyzing the primary missions of these vehicles, as a collective whole, they paint a limited capabilities picture. As seen in Figure 2.1, each system listed is primarily designed as a reconnaissance and surveillance platform; only half have target acquisition capabilities [58]. The Fire Scout in use by the Navy is the only rotorcraft in this UAV list, and its target acquisition mission is not offensive in nature but limited to spotting for other attack platforms [64]. The Hunter and Shadow UAVs perform similar target acquisition missions but are also not designed for offensive engagements [49] [28]. Of the seven listed systems here, the Predator is the only one to date to have fired a missile in support of combat operations. Furthermore, it only recently achieved initial operating certification in March of 2005 [45]. At the present, the range of UAV missions is limited mostly to reconnaissance; only the Predator is capable of performing attack missions on targets.

Also in Figure 2.1, each system's navigational capability is listed after being classified into three general categories. Presently, UAVs are controlled by either remote controlled guidance, pre-programmed waypoints, or through varying levels of autonomy that dictate the vehicle's actions. After the early "autonomy" used by World War II Japanese forces in their attack balloons, the majority of UAVs utilized remote control guidance as evidenced in older Predator and Hunter UAV (initiated in 1989) systems [28]. Recently developers incorporated preprogrammed waypoints into control of UAVs by using the Global Positioning Satellite (GPS)

system; this capability is seen in the Dragon Eye, Dragon Warrior, the Global Hawk, and Shadow 200 system [13][49]. The only vehicle listed in the above chart with sole autonomous controls is the Navy's Fire Scout unmanned helicopter. However, the pure autonomy indicated there is a slight misnomer as the vehicle also uses other flight control methods. According to its developers at Northrop Grumman, the autonomy is only found in the takeoff and landing phases of the vehicle's mission and navigation can either be pre-programmed or updated by ground controllers through keyboard inputs [64].

2.2 Autonomous UAV Development

With each of the previous UAVs mentioned, the level of autonomy varied but still supported the overarching intention of primarily using unmanned vehicles as reconnaissance platforms. However, two particular defense programs either sought or are seeking to use more sophisticated levels of autonomy to expand strike capabilities in missions employed by UAVs. The concept of these programs lend credence to the belief that researching and developing new or modified tactics for UAVs is advantageous; this supports the notion that the fundamental mission of UAVs may not always be reconnaissance and surveillance.

2.2.1 DARPA UCAR Program

The Unmanned Combat Armed Rotorcraft (UCAR) program was a joint venture between the United States Army and the Defense Advanced Research Project Agency (DARPA) to build never before seen levels of autonomy into a team of manned and unmanned helicopters [61]. Initiated in early 2002, the project was important as it sought to advance the use of UAVs in operations other than reconnaissance. The fundamental premise was to use a group of rotorcraft in combat by building a team of vehicles that "hunted" their prey like a wolf pack. The joint venture was cancelled prematurely in December 2004, yet the idea of an airborne controlled UAV platform prompted many questions into what tactics these vehicles would execute on their own to reduce the workload of the human operator and provide greater mission effectiveness.



Figure 2.2: Visualization of UCAR concept ^[33]

As seen in Figure 2.2, the UCAR vehicle would collaborate with other unmanned vehicles in addition to a manned helicopter, envisioned to be the Comanche and later the Apache. However, as the workload placed on pilots is already high when flying a mission, the autonomous rotorcrafts were to operate on a highly independent level away from the manned asset that controlled it. Verbal commands would have been given to the vehicle to minimize the human workload, and attack missions were explored as one of many missions to be performed by the teamed group. Despite this program's cancellation, this program was a viable attempt to build higher levels of autonomy into vehicles, capabilities greater than waypoint navigation or autonomous take off and landings. Furthermore, the combat missions espoused in this project are likely to come to fruition in future projects seeking to use higher levels of autonomy.

2.2.2 J-UCAS

The Joint Unmanned Combat Air Systems (J-UCAS) is a combined effort between the Navy, Air Force and DARPA to field an unmanned robotic attack jet, known as the Unmanned Combat Aerial Vehicle (UCAV). The program is currently managed by DARPA after a merger between two separate Air Force and Navy projects seeking similar goals. In the competition to field the vehicles, two teams, one lead by Northrop Grumman and the other by Boeing, have test flown prototypes of their vehicles designated the X-47B and the X-45C, respectively. The designs of the two prototype airframe can be seen in Figure 2.3 [31].

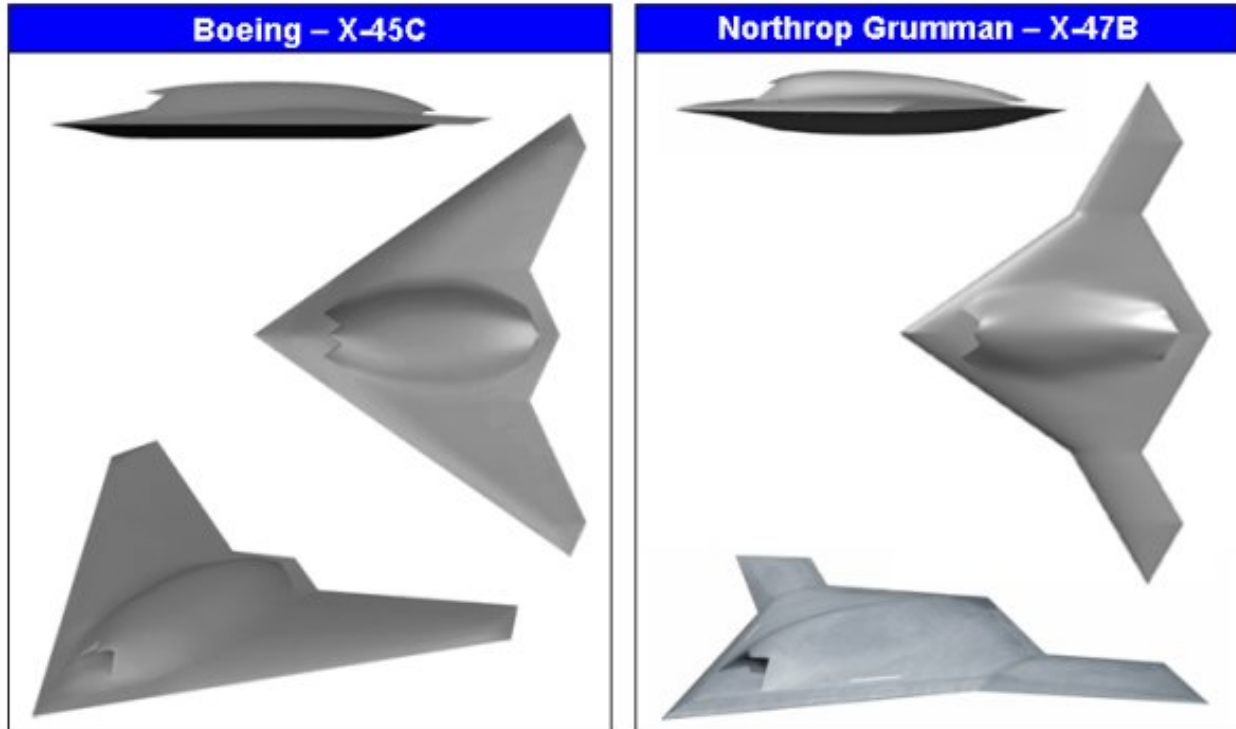

Figure 2.3: J-UCAS UCAV Prototypes ^[31]

The goals of the program and the importance of this development are two-fold. The first is to build and demonstrate an unmanned vehicle with the ability “to prosecute 21st century combat missions” [31]. In detailing the missions, DARPA specifically lists execution of Suppression of Enemy Air Defense (SEAD), surveillance, and precision strike. In targeting these missions, the J-UCAS vehicles will be primarily oriented as attack platforms. The RQ-1A Predator, the first UAV to use a missile in combat, was originally designed as a reconnaissance platform and then later modified to perform attack operations. The J-UCAS program is an effort to specifically design an aircraft for offensive employment.

The second goal of the program and the reason it represents a sizeable step in the development of attack vehicles, is that the J-UCAS program intends to automate sizeable portions of the UCAV’s operations [8]. The UCAV vehicle will hunt in packs like the unmanned helicopters in the UCAR program were designed to; as a contrast, the Predator currently only attacks alone and by remote control guidance. This important goal is significant for the program intends only for humans to interact with the vehicles when necessary or preferred, at instances when a mission replan is necessary or if munitions need clearance for firing. To accomplish this, the vehicles are designed to be highly networked and capable of “communicating” with each other to accomplish the attack missions listed above. To show the potential employment of these aggressive, attack-oriented UAVs, Figure 2.4 shows a full scale engagement utilizing UCAVs in communication with each, gathering target acquisition data from satellites, and attacking targets on the ground.

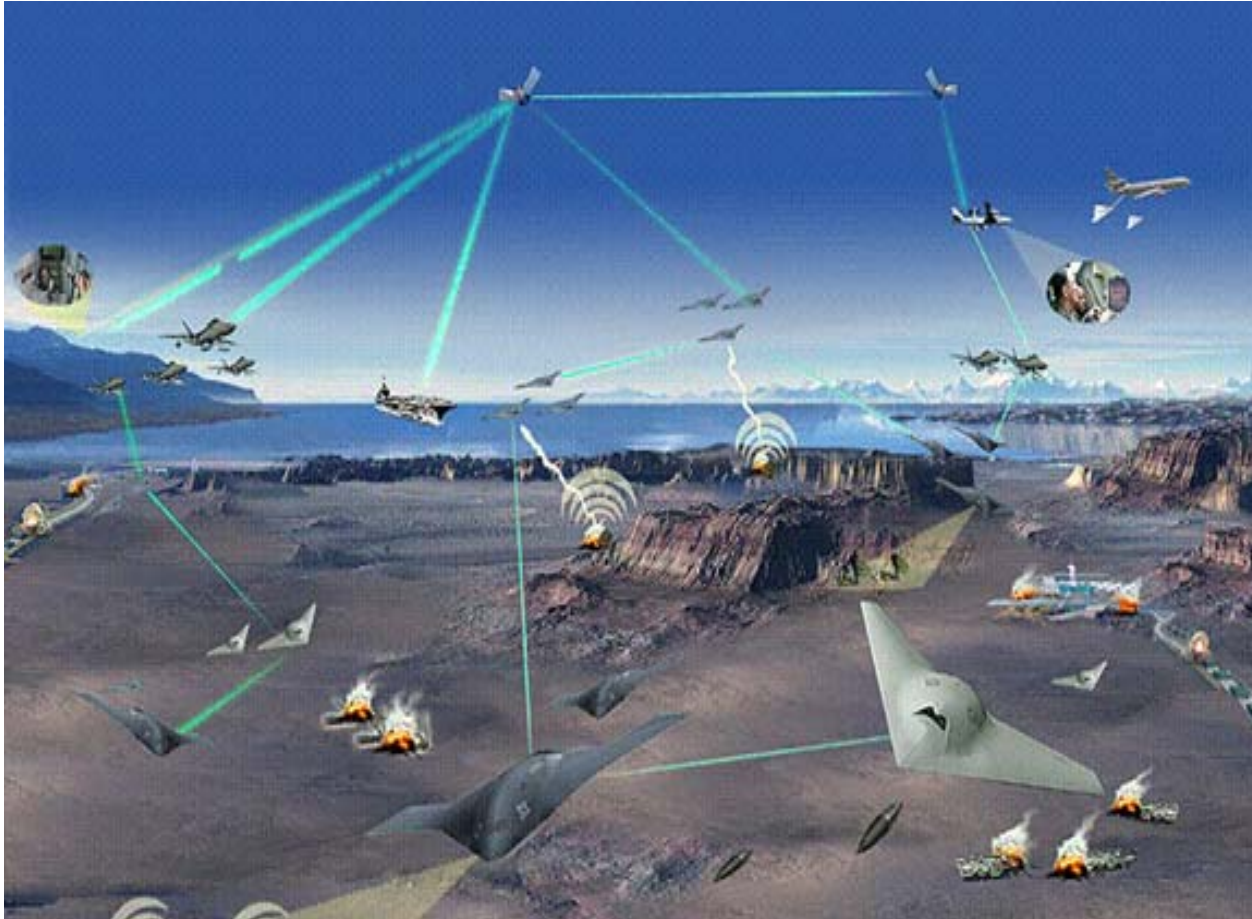

Figure 2.4: Networked Engagement of UCAV Aerial Vehicles ^[30]

The J-UCAS and UCAR programs build off the baseline reconnaissance mission in developing new ways to employ unmanned vehicles in supporting military missions. In particular, these two programs sought or are seeking to automate attacks after human confirmed target identification. However, in addition to offensive operations, unmanned vehicles of the future might be required to perform a full array of military missions. With a need to execute these missions, the behaviors the vehicles execute must be evaluated, tested and programmed – more specifically, the tactics unmanned vehicles execute in the future must be developed to maximize each vehicle’s effectiveness both offensively and in support of other missions. However, autonomy can be built into many aspects of executing a mission; clarification is needed on what level this research is seeking to automate.

2.3 Autonomous Hierarchical Planning Levels

In defining *tactics*, we present the following section to show the various hierarchical levels of planning for autonomous vehicles. Tactics can take on a wide array of different meanings and it is the purpose of this section to define clearly where the statecharts and

corresponding six tactics fall in terms of envisioned use. To aid this discussion, Figure 2.5 shows five categories ranging from the higher level allocation of entities to a mission to the lowest level of autonomous trajectory generation. We show that our use of tactics falls towards the lower half of the spectrum yet above flight parameter generation.

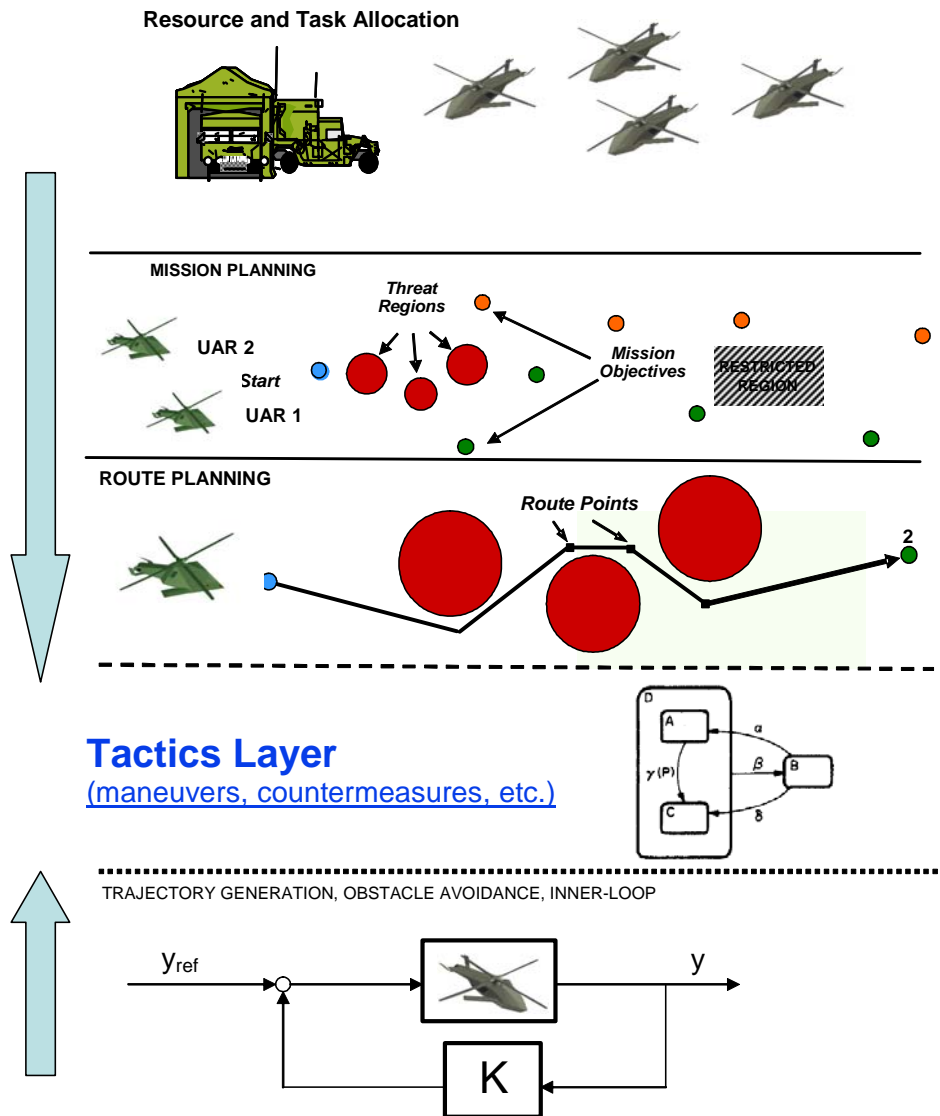

Figure 2.5: Hierarchical Planning of Autonomous Vehicles ^[62]

In using unmanned assets, the highest level of planning entails resource and task allocation. At this level, planning involves determining the optimal number of unmanned vehicles and necessary support equipment to accomplish the objective. Currently, autonomy can dictate the number of vehicles required to reconnoiter an area effectively with a certain percentage of coverage. For attack missions, humans would likely be involved to approve or disapprove the recommended force and in these instances, autonomy is used more as a decision tool. However, autonomy could perform all the necessary planning in the future to allocate resources based on intelligence reports on the enemy force.

The second tier of planning for unmanned vehicles is the mission planning level. At this stage, planning is necessary to take the number of assets generated in the first tier and optimally use them in the course of a mission. This level is analogous to a division of labor stage, and is particularly useful in the context of a reconnaissance search, for example. At this stage, autonomy is useful in segmenting the area to be covered into equal areas and assigning each vehicle an area based on present position or other factors if so determined. Also, vehicles that might have greater capabilities could be assigned particular quadrants if an attack vehicle was needed to destroy potential pop-up targets in a certain area.

The next level down involves route planning. In using our reconnaissance example above, at this tier autonomy determines the path a vehicle would take while scanning the objective area. The vehicle in this example would use intelligence received and fed into it ahead of time to plan for optimal coverage of the terrain to be scanned. Furthermore, at this level, the individual vehicle would have to take into consideration a multitude of things to increase its survivability to include maneuvering around known high threat zones and other dangerous areas.

Below route planning is where we define tactics. It is at this level we define our problem of developing a methodology that aids in determining the behaviors a single autonomous rotorcraft should execute in a mission. More specifically, we seek to take advantage of the added aggressiveness afforded by the use of an unmanned vehicle in better accomplishing a mission than a manned asset. We assume the mission is pre-determined and the trajectory generation is handled; here at this level we seek a formulated method to determine how best to incorporate autonomous actions into our rotorcraft. In particular, we will use statecharts to show the events and transitions that will occur in diagramming six possible tactical uses of autonomous rotorcraft. The statechart and its applicability to behavior representation are discussed more in Chapter 3 when a description of the methodology is discussed in full.

Finally, at the lowest level of planning is trajectory generation. While performing the tactics described in the level above it, autonomous vehicles would utilize sensors to calculate and follow specific trajectories to perform ground avoidance and optimal flight following. In this lowest level of autonomous planning, control loops are executed to insure the vehicle plans and follows a specified flight path. While some of the tactics described in this thesis may reference certain maneuvers, it is not the intent of this thesis to present research on trajectory generation.

2.4 Tactics Development Research

This section explores how tactics have been tackled by a variety of different researchers, but concludes that the majority of them have used qualitative arguments to support their findings. Nevertheless, a brief discussion of some of the research found is pertinent for the contributions towards developing helicopter tactics.

Setting the tone for transforming tactics is a 1980 Master's thesis that qualitatively assesses the roles of army helicopters [6]. Entitled "Attack Helicopter Employment Options," Major Michael Brittingham discusses the roles of helicopters in the Army. He argues that these roles should be expanded beyond their then use. Brittingham advocates for more aggressive employments against enemy air defense while behind enemy lines. He further states the primary utilization of attack helicopters as tank killers is limiting and not their best mission. Of particular importance, this thesis shows that the use of attack helicopters should always be reevaluated in light of changing conditions and possible expansion of capabilities.

The earliest document actually found, though, outlining the tactical employment of UAVs by the armed services is the Joint Pub [publication] 3-55.1: Joint Tactics, Techniques, and Procedures For Unmanned Aerial Vehicles [40]. This document was first released in August of 1993 and discusses higher level considerations concerning the employment of a UAV in joint operations. As a reflection of the only UAV missions performed at the time, the publication states a UAVs primary mission is "as a tactical RSTA (Reconnaissance, Surveillance, Target Acquisition) system providing the commander a capability to gather near-real-time data." The joint publication further dates itself by stating that "the UAVs discussed in this publication are nonlethal," a reference that predates the use of the Predator launching Hellfire missiles. The document does define five categories for UAVs to include the close-range, short-range, vertical takeoff and landing (VTOL), medium-range and endurance UAV. In addition, the missions that the publication envisions UAVs executing are listed, although little in-depth analysis of each mission's need for a UAV is provided.

Major Mark Mazarella also tackled and challenged then current doctrine in his 1994 Master's thesis for the U.S. Army Command and General Staff College [34]. In his paper entitled "Adequacy of U.S. Army Attack Helicopter Doctrine to Support the Scope of Attack Helicopter Operations in a Multi-Polar World," Major Mazarella uses qualitative means to assess whether attack assets are effectively being used in the subsequent years following the collapse of the Soviet Union. While he does not discuss the employment of UAVs or autonomous vehicles, Major Mazarella does heavily incorporate into his analysis the use of field manuals and whether the doctrine they outline are pertinent in light of current operations. His thesis serves as an excellent primer in understanding combat operations for the Army aviation novice. Furthermore, his eight specific recommendations at the thesis's conclusion highlight gaps in manned attack helicopter employment that could very well be realized in UAV employment; it would be easy to interchange his comments on the need for continual development of manned tactics for the current need to develop unmanned tactics.

Simulating Hierarchical Planning Levels

In addition to research qualitatively discussing tactics development, we present background information about other methodologies in which simulation has been used to model UAVs. In particular, we discuss papers on how others simulated the rotorcraft acquisition process, modeled synthetic intelligent agents on a battlefield, and finally how some researchers in particular sought to automate tactics through the use of human performers in a driving simulator.

As the tactics hierarchy in Section 2.3 varied from resource and task allocation down to trajectory generation, simulations can be used to model possible UAV tactics at varying steps of these levels. In his 1999 Masters thesis for the Naval Postgraduate School, Captain Garret Heath developed his own simulation to answer questions particular to unmanned rotorcraft such as, “what are the Tactics, Techniques, and Procedures (TTPs) for the use of this system?” [23] Captain Heath used the discrete-event simulation Simkit to develop a Java-based simulation that he used to answer specific questions about the performance aspects of UAVs. In developing a simulation modeling the highest level of tactics, task allocation, Heath addresses UAV endurance capabilities and the number that could be employed in an engagement to achieve maximum effectiveness. Captain Heath also states his model could be effective in the acquisition process for unmanned rotorcraft to determine which capabilities (range, endurance, maintenance needs) should be more heavily weighted. Furthermore, Captain Heath presents two important concepts that influenced the methodology design. The first is that he chose a different visual formalism to model the events and transitions that occur in the system he developed. As opposed to using statecharts, Captain Heath used the following event graph to represent the key events and transitions occurring throughout his simulation.

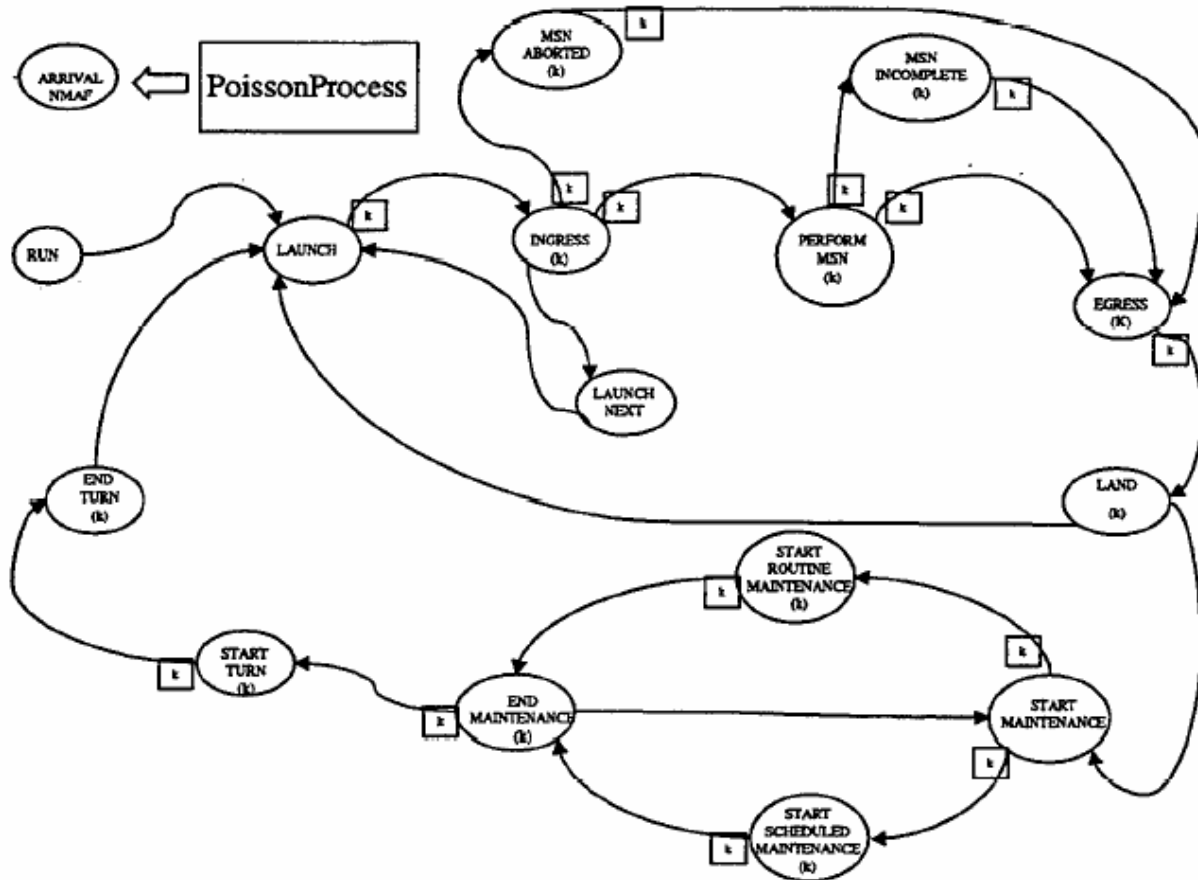

Figure 2.6: Event Graph of UAVSim [23]

As seen in the diagram, Captain Heath used his simulation to tackle higher level resource allocation problems including maintenance breakdowns and turn around time to provide estimates on the reliability of maintaining continuous UAV reconnaissance. This methodology presented one option to model tactics, although it was eventually decided to pursue a different manner to represent a rotorcraft’s behavior. By neglecting the outside influence of possible events on his UAVs, this model assumes out factors beyond the individual entities’ control. Captain Heath’s simulation represents an excellent method to modeling events, albeit not reactionary based ones which are likely found at the tactics level of hierarchical planning.

The second contribution to the thesis is one statement Captain Heath makes concerning the need for iterative simulation runs in developing *any* tactics. In discussing his methodology for developing the simulation, Captain Heath states that “analytic (mathematical) models as well as other Monte Carlo simulations are used to assist in verifying the portion of the model that evaluates the performance of TUAV [Tactical UAV] systems.” Captain Heath acknowledges that Monte Carlo simulation runs are needed when evaluating the tactical performance of an advanced system. His findings were taken into consideration and later incorporated into the use of the OneSAF simulation described later.

A second paper highlighted research into the use of simulation to develop tactics. A group of researchers at the University of Southern California tackled two planning levels by modeling the tasks performed by a company of attack helicopters [26]. Entitled “Intelligent

Agents for the Synthetic Battlefield: A Company of Rotary Wing Aircraft,” these researchers used the Soar integrated architecture to address behaviors at the mission planning and the tactics level. They accomplished this by creating autonomous helicopter entities capable of executing a generic attack mission from start to finish; these helicopters actually executed the popup fire attack tactic to be described later. One benefit of the research was in furthering mission planning through task allocation for a company of helicopters. Using a ModSAF simulation, these researchers automated the mission planning from a command agent to the eight helicopters comprising the attack helicopter company. Development of the project was still ongoing at the time of the paper’s publication, but the work done by this group represents one viable stab at using simulation to develop tactics for an autonomous rotorcraft.

A final group of researchers outlined a more observation based methodology to replicate and automate military behaviors on the tactics level. In attempting to copy manned performance intelligently, Hans Fernlund and Avelino Gonzalez answered the problem by drawing an interesting analogy. Fernlund and Gonzalez said autonomous car-driving behavior could be developed based on the actions of vehicle-driving humans [16]. In their paper entitled “Evolving Models of Human Behavior Representation from Observation of Human Performance in a Simulator,” Fernlund and Gonzalez begin by acknowledging the difficulty in incorporating the knowledge from subject matter experts (SME) in the model engineer’s design. However, based on the different possible ways to interact with the SME, Fernlund and Gonzalez determine learning from observation best replicates a subject’s actions in a manner that can be later developed for automation.

In order to learn by observation, Fernlund and Gonzalez use a “novel approach that employs genetic programming in conjunction with Context-Based Reasoning to evolve such models based upon automatic observation of a human expert performing a mission on a simulator.” In their methodology, humans are used in the simulation as the pair of researchers place five different drivers behind the wheel in a simulated driving experiment. By measuring certain quantifiable properties, such as speed through the course and whether drivers run or stop for yellow lights, the researches developed five distinct autonomous agents based on the five drivers tested. The intelligent agents themselves, then “performed” in the simulator and the differences in behaviors were recorded and analyzed. Ultimately, the research advanced a new methodology of combining the knowledge of the subject matter expert concurrently with a simulation. Fernlund’s and Gonzalez’s research proposed one way to a faster approach in representing behaviors; they also acknowledged the process could be mirrored in developing autonomous manned tactics for military applications.

In this Chapter, we have laid the foundation for understanding current unmanned tactics. In addition, discussion has covered the missions and the level of autonomy to be researched in this thesis while highlighting other research on qualitative assessments of tactics and the use of simulations in modeling behaviors. In the following section, we build on this baseline to present the methodology used to research, formulate and test behaviors for single vehicle autonomous rotorcraft.

Chapter 3 Design and Methodology

In this chapter, we discuss the design and methodology of the three pronged approach used to formulate and propose tactics for future autonomous rotorcraft and their representation via statecharts. Initially, we outline how all three elements were used in the converging spiral for recommending the six tactics presented in Chapter 4. This methodology is laid out initially to provide the framework for understanding how each aspect was used iteratively in the process.

After laying out the constructs of the design methodology used in this thesis, each facet is presented in detail. Discussion first centers on the use of United States Army Field Manuals (FM) and recent literature from ongoing conflicts that influenced the design process. Afterwards, we outline the involvement of subject matter experts to include planners, pilots and simulation developers. We then discuss the framework used to visually represent each of the six tactics developed. Known as statecharts, these diagrams of reactive systems are briefly summarized based on work by Harel; they are then discussed for their potential benefits in representing tactics. Finally, we describe the OneSAF simulation program and the modifications made to its original structure necessary for this thesis research.

3.1 The Converging Spiral

In determining an appropriate geometric shape that describes the proposed methodology, the converging spiral seen in Figure 3.1 most accurately describes the process. In placing the four key components of the methodology, the initial loop accurately reflects the preliminary formulation of the tactics. At the beginning, field manual research provides the necessary background information to understand the Army aviation and its role within the service. Following the field manuals, but also weaved within them, are interviews with subject matter experts (SMEs). Afterwards and occurring predominantly at the end of the tactic refinement, were simulations of each of the tactics. Finally, the statechart is presented as the final representation of the tactic and is ultimately the recommendation for an autonomous rotorcraft's behavior during the tactic. Each statechart was developed and modified with continual updates of information, and all statecharts were designed with the Microsoft Visio drawing application.

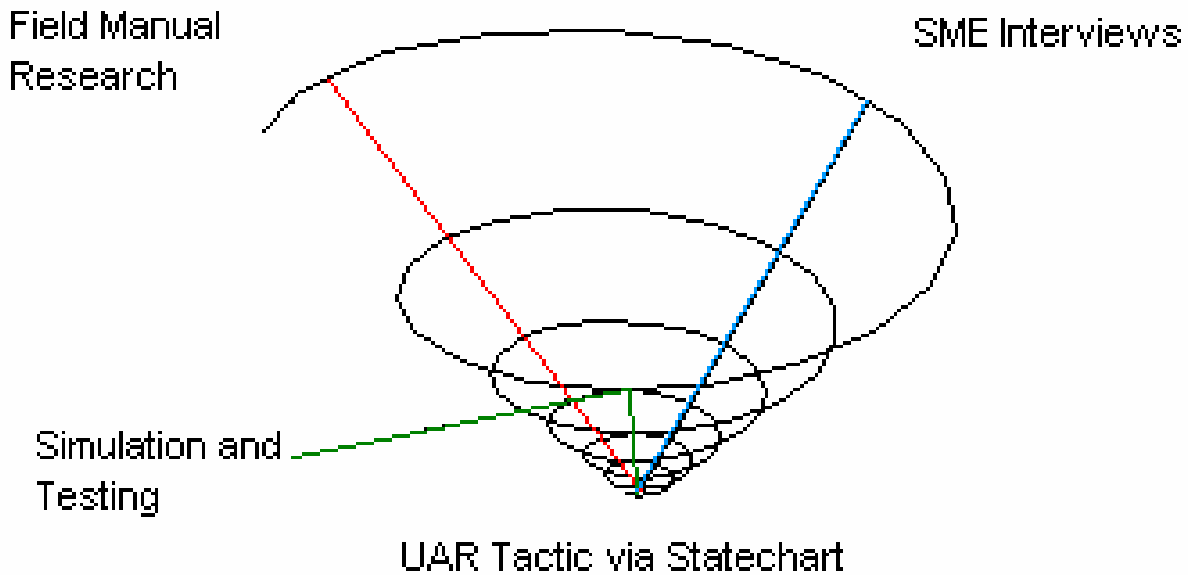

Figure 3.1: The Converging Spiral of Autonomous Rotorcraft Tactics Development

However, the core of the methodology is that the spiral visits each of the four areas iteratively. In this recursive design, feedback from each of the different sources can be integrated thus effectively narrowing the tactic each time to make it more realistic, lifelike, and plausible for use in Army operations. The output, as seen at the bottom figure, is a tactic that has passed both doctrinal (field manuals) and common sense (SMEs) checks while carrying some degree of support from partial validation in an Army designed simulation. With all this iterative refinement in the methodology, one could assume the end tactic should be “anointed” in describing how all autonomous rotorcrafts should operate in the future. However, this statement could not be farther from the truth. As the dynamics of warfare consistently change, the tactics employed should change with it. The proposed tactics, then, may only be valid for a finite period

of time in the future; consequently, they may never become integrated. Nevertheless, the six tactics represent a foundation for which subsequent research can build by reinserting them at the top of the spiral and thus restarting the refinement methodology. Or, after development in the statechart, these tactics could be developed further to include testing in live, simulated exercises and potentially in real operations.

3.2 Field Manual Research

The United States Army uses field manuals as a means to document and standardize the practices, rationale and actions of its service. The field manuals themselves number well over one hundred, and they outline general methods for planning and executing Army missions ranging from Engineer Operations Short of War (FM 5-114) to Explosive Ordinance Disposal Service and Unit Operations (FM 9-15). Soldiers use the manuals primarily as reference material either in gaining background information or clarifying daily operations; they are generally not intended as checklists for executing specific tasks. To this end, these lengthy documents typically focus on general, higher level events considered in the course of planning or organization. Nevertheless, they are a valuable source of information to those with little background knowledge attempting to understand tactics within Army aviation.

In this thesis, the primary focus was on understanding and developing tactics particular to flying operations; likewise, the field manuals researched and referenced corresponded to this aim. Most helpful in this goal to understand the Army's use of aviation assets were FM 1-100, 1-114, 1-112, and 1-140. FM 1-100 is an all-encompassing manual covering the general use of aviation to support the Army's strategic goals and is intended for all operation levels from planning to execution. FM 1-114 outlines the use of Air Cavalry and squadron operations; it is written for higher level commanders but also "serves as a reference for flight crews learning to conduct reconnaissance and security operations" [20]. FM 1-112 focuses primarily on the planning and battalion level execution of attack operations helicopter operations, and FM 1-140 goes into further detail on offensive engagements by examining gunnery operations for helicopters. In addition, and of particular use in this research, FM 1-140 makes recommendations for achieving maximum effectiveness in the use of certain weapons.

Additionally, non-aviation manuals were studied to gain more background to a particular operation. FM 17-95 on Cavalry Operations provides a clear structure to the different echelons of security and is one example of a non-aviation manual being consulted. In addition, other Army publications provided key background information. Although not given the field manual moniker, the AH-64D Apache Aircrew Training Manual, TC 1-251, provides specific training requirements for effective execution of certain attack level tactics. Each of the above manuals is referenced throughout the thesis as specific information is pulled from them.

Field manuals were incorporated into the methodology for a multitude of reasons, but primarily to achieve two specific goals. One intended benefit in using them to develop tactics is it enables the user to understand specific terms and acronyms used currently in the field. As an example, to the neophyte researcher the flight altitude term "low-level" would appear to be flight at the lowest level. However, FM 1-112 reveals this as a fallacy as they describe that low-level flight actually applies to an altitude representing the highest level at which helicopters typically travel. Researching through field manuals also makes the reader knowledgeable of confusing acronyms. As in the previous example with helicopter flight altitudes, the acronym NOE is used

often to mean “flight as close to the earth’s surface as terrain, vegetation, obstacles and ambient light will allow.” [42] Written out as Nap of the Earth, this extremely important acronym dictates a flying principle important to both Army planners and pilots for maximizing survivability.

The second and perhaps more important intended benefit of using these field manuals is to understand how tactics are executed at the present by manned assets. In order to develop and propose Tactics, Techniques, or Procedures (TTPs) for future autonomous rotorcraft, we argue it is important to understand current methods so as to have a baseline from which to build. In most instances, tactics are executed in a particular manner with feasible rationale. In understanding this rationale, the developer can evaluate his own work and realize why it is not recommended, for example, to fly at higher altitudes in hostile terrain (decreased survivability, among others).

In addition, to propose tactics without any sound understanding of current operations forbids the developer from defending his points based on how a tactic could soundly be advanced. If aware of how manned assets attack, for example, the researcher can support his basis for having an unmanned rotorcraft performing counter to the “way we do things.” (This backwards thinking mindset, while not encountered in the researching of this thesis, is nevertheless a possible opposition when recommending changes at any organization.)

3.3 Subject Matter Expert Interviews

The second aspect of the three-pronged approach to developing tactics involved interviews with subject matter experts (SMEs) in the fields of simulation, planning and execution of rotorcraft tactics (pilots). Before introducing the individuals questioned and their backgrounds as verification of their status as SMEs, we first present the justification for using SMEs in the process.

The rationale for incorporating SMEs into the overall methodology was three fold. The first reason is their ability to provide insights not easily gleaned from the field manuals. Quite often, principles or techniques explained in field manuals were not easily understandable and pilots interviewed were able to fill in the gaps while helping to clarify the Army jargon. As an example, when it comes to a rotorcraft’s ability to hover, the power considerations needed to maintain a constant altitude are significantly influenced by whether the aircraft is IGE or OGE (In Ground Effect or Out of Ground Effect). Throughout the field manuals these two acronyms are referenced with regards to maneuver capabilities and the hovering fire tactic, yet besides the spelled out words in the glossary, little background information on these acronyms was found. In the course of one of the interviews, one pilot quickly explained the significance; if hovering in ground effect the aircraft requires less power. In ground effect, additional lift is generated by the rotors thus making hovering at low altitudes easier on the rotorcraft’s power generation. In addition to this one, there were many more instances where a simple pilot explanation was able to elucidate confusing aspects in the field manual.

The second major contribution and reason for use of subject matter experts was their ability to shed light on how tactics have changed in recent engagements. As an example, Captain Myers, having flown during the initial engagements of Operation Iraqi Freedom from February 2003 to February 2004 discussed the use of combined arms to fight engagements in the theater. During a particular interview with him, Captain Myers pulled out maps of his AOR (Area of Responsibility) and detailed the planning that went into the attack mission. He was able to

provide current tactical descriptions of how the ingress routes were flown, where the enemy was encountered and how his company reacted, and also lessons learned from the engagement. In addition, his assessments on the current situation in Iraq being a far departure from the engagements expected in the Cold War or that happened in the Persian Gulf War were invaluable.

Finally, the third reason subject matter experts are included in the methodology is for their knowledgeable feedback in the areas they represented. In particular to pilots, feedback would focus on the proposed ideas and the actions within the statecharts; however other advice provided insightful concerning the methodology of the thesis.

For this research, the following people were considered as pilot SMEs. Captain Kevin Myers is an AH-64D Apache Longbow pilot with over 1250 hours spanning the course of nine years. Most recently, he served as the commander of an Apache Longbow company in Iraq from February 2003 to February 2004, accumulating 275 combat hours while in theater. Captain Tyler Smith is a UH-60 Blackhawk pilot also having served in Iraq from February 2003 to February 2004. He also has approximately 1250 hours flying experience in the Army over the past nine years. In addition, Major Mike Odom is an AH-64A pilot with over 1100 hours in various helicopters, the majority of which were in the Apache. His insights from more than seven years of flying were profoundly influential in the development of the statecharts presented later.

In addition to the above mentioned pilots interviewed by phone, email, or at their homes, two more pilots were questioned at Fort Rucker, Alabama, the schoolhouse for Army Aviation where most primary helicopter training occurs. Chief Warrant Officer (CW4) Michael Wells is an Apache pilot with over 15 years experience and 3,150 flying hours; CW4 Terry Gibson has flown the Kiowa airframe for 17 years accumulating over 3,400 hours. All total, the pilots interviewed have flown more than five different airframes including all those used for attack missions in the Army; cumulatively, they have over 10,150 hours of experience spanning 57 years.

In addition to interviewing pilots, both computer simulation experts and aviation project officers were consulted in formulating the methodology and tactics. At the Air Maneuver Battle Lab (AMBL) in Fort Rucker, Alabama, Mr. Thomas Akin is a computer simulation specialist who works primarily with the development of rotorcraft modeling to represent actual scenarios. Furthermore, Mr. Jim Delashaw is a project officer at the AMBL who works on a conglomeration of aviation projects for the Army; Mr. Delashaw in particular provided insight into OneSAF and the use of it as a tool to represent tactics. Finally, Mr. Michael Hasley is a senior analyst at the AMBL who has worked extensively on the Army's Hunter Standoff Killer Team (HSKT), a project to place the Hunter UAV feasibly under the control of Apaches.

3.4 Statecharts

In the following section, we present the third part of our methodology to represent tactics for autonomous vehicles. As the concept of statecharts serves as a key principle of the thesis, we present substantial background information on these diagrams and how they differ from other methods of visually representing complex systems. To begin, we give a brief synopsis of what exactly constitutes a statechart followed by a presentation of how it differs from commonly used state transition diagrams. Afterwards we present the key example as outlined by Harel in his

presentation of the charts, and finally explain the rationale for selecting statecharts as part of the methodology and the intentions of choosing this particular visual illustration.

In the following paragraphs is a brief summation as presented and explained by David Harel in his widely-cited, 1987 paper, "Statecharts: A Visual Formalism for Complex Systems." [17] In his paper Harel discusses both the evolution of the statechart concept in addition to citing a specific example throughout his paper showing an easily understood, yet complex system. Using his Citizen Wristwatch, Harel effectively explains the essence of statecharts while showing the fundamental difference between his charts and other manners by which to model complex systems.

Essentially, statecharts present a manner for representing the events and transitions in a system. Harel admits the name "statechart" is not the byproduct of a deeply insightful creation; he rather states this "mundane name was chosen, for lack of a better one, simply as the one unused combination of 'flow' or 'state' with 'diagram' or 'chart'." In some ways, they can be considered distant cousins of the flow chart; a statechart, like a flow chart, simply helps a user follow the paths through a system. The flow chart will often have a simple language of "yes" or "no" criteria with nodes and arrow to help the user through a straightforward process. The statechart, however, incorporates a slightly more difficult "language" that facilitates the development of more complex systems. Finally, and perhaps most important, statecharts are designed to model reactive systems; this emphasis is discussed later in the context of modeling behaviors conditional upon the outside influences on a system.

In pulling the watch example from Harel's paper, we explain the basics of statechart modeling through Figure 3.2. The initial arrow extending from the small, black circular node shows that upon entering the display state of the watch, the first substate is that of displaying the time. Once the time is displayed, we see the reactionary nature of statecharts; until a button is pushed on the watch, the time will display indefinitely. Should the user push the "d" button, though, the date is displayed, and if pressed again, returns the display to the time event. If the user forgets to press the "d" button again or simply chooses not to, then the transition occurs automatically after two minutes of time.

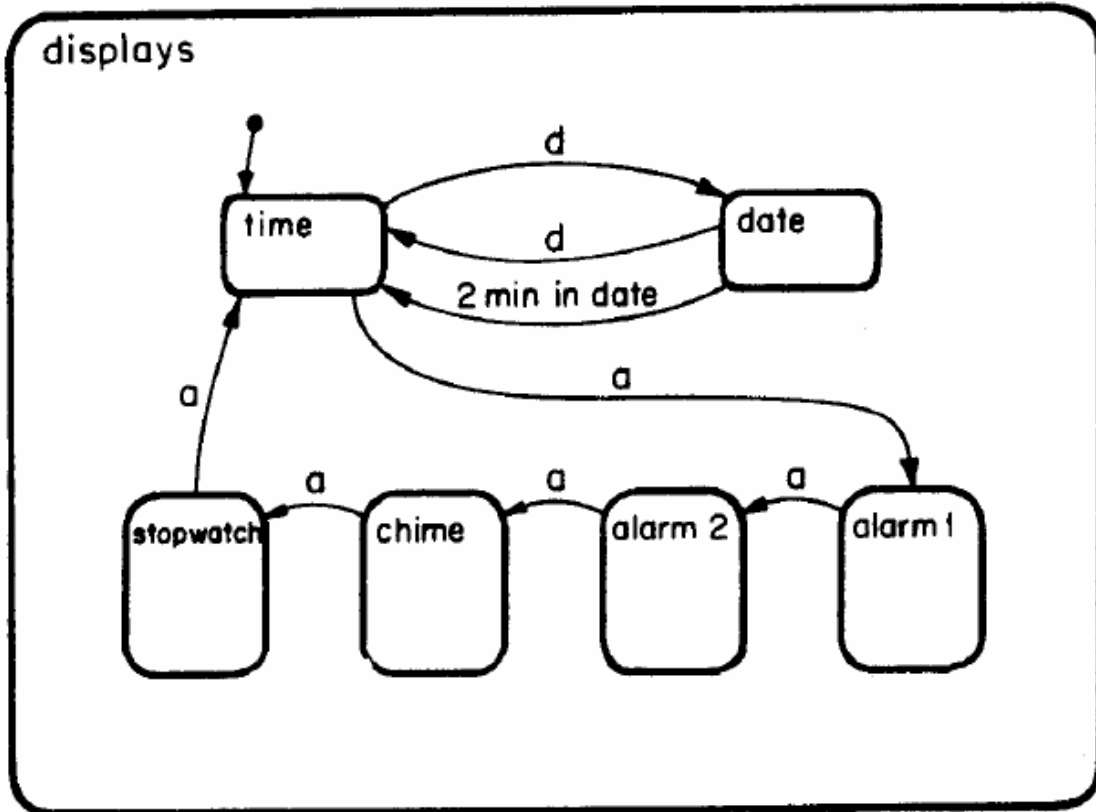

Figure 3.2: High-Level Wristwatch Statechart ^[17]

If back in the time state or in it for the first time, pushing the “a” button sends the watch wearer through a string of different states. The transitions occur at each reaction to the “a” button being pushed taking the user through the alarms, chime settings, and stopwatch before returning the system to displaying the time. Within each of these states, Harel shows substates for each in his paper. In doing so, Harel mentions one of three key advantages that statecharts hold over other methods for diagramming systems.

For comparison purposes, the diagram that Harel evaluates his idea against is the state-transition diagram, or state diagram for short. However, Harel claims improvement upon the basic state transition diagram on the basis of the following equation:

$$\text{Statecharts} = \text{state-diagrams} + \text{depth} + \text{orthogonality} + \text{broadcast-communication}$$

Figure 3.3: The Statechart “Equation” ^[17]

Depth

In “adding” depth to the state-diagram, Harel discusses the statechart’s ability to cluster similar states together by means of a superstate. In offering a real-life analogy, Harel uses the simple design statement that “in all airborne states, when yellow handle is pulled, seat will be

ejected.” Harel proceeds to explain this fundamental notion of his statecharts by referencing the differences between the following two figures. In Figure 3.4, the state-transition diagram shows the three states in boxes as A , B and C and the transitions between the arrows as dependent on certain reactive systems occurring. For explanation sake, state A can be considered flying inverted while state C is flying upright; state B is the event of ejecting from the aircraft. Therefore, in using our simple design statement, the “yellow handle pulled” becomes the transition β where irregardless if in state A or C , the system will transition into the ejection state, B , whenever the handle is pulled. (The other transitions, save β , can be neglected for now.)

For summation purposes:

State A : Flying upside down, or inverted

State C : Flying right side up

State B : Ejection State

Transition β : The act of pulling the handle

Transitions $\gamma(P), \delta, \alpha$: Neglected for this example

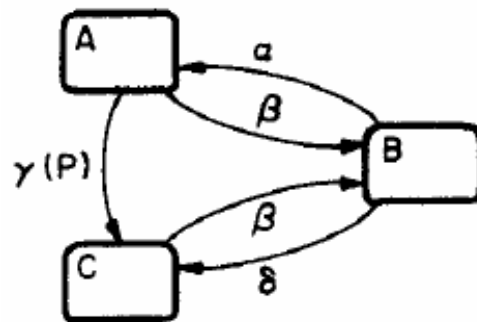

Figure 3.4: State Transition Diagram ^[17]

In Figure 3.5, Harel presents the added sophistication of depth in statecharts by introducing clustering. By grouping *A* and *C* into superstate *D*, the conditional transition of pulling the ejection handle, β now comes out of the superstate *D*. State *D* is actually an abstraction of states *A* and *C*, yet is important for it reduces the number of arrows needed to show this system. More importantly, it adds the component of depth. The clustering of the two flying states together (inverted, *A*, and upright, *C*) enable the transition of pulling the ejection to occur while flying, state *D*, without having to go in depth to determine at what attitude the aircraft is flying (upright or inverted). A visualization of neglecting the depth, or contents of state *D*, is shown in Figure 3.6.

The state-transition diagram in Figure 3.4 shows all events and transitions as being “flat” on one level. The statechart, however, shows that only states *D* and *B* are on the same hierarchy level when considering the ejection transition β . For the purposes of the “flying to ejection” transition, states *A* and *C* are subservient to state *D*.

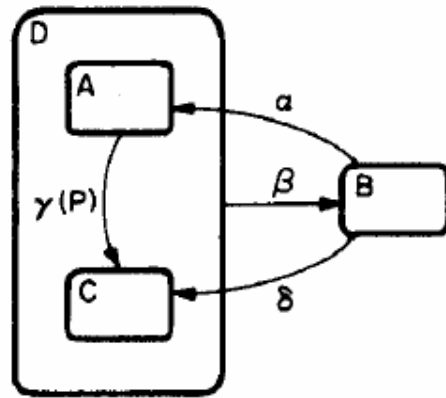

Figure 3.5: Statechart Representation ^[17]

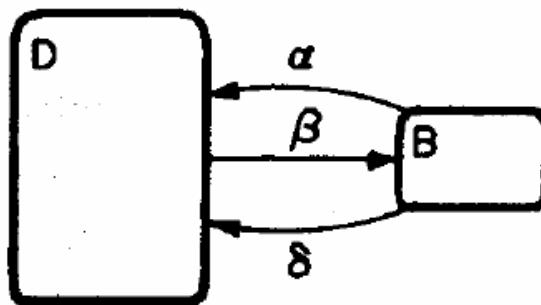

Figure 3.6: Statechart Depth Hidden in State *D* ^[17]

Orthogonality and Broadcast Communicability

The final two additional benefits of statecharts as compared to state diagrams is the principle of orthogonality, or the ability to easily represent “AND” decomposition. In order to visually show two states executing in concurrence, Harel uses a dashed line as seen in Figure 3.7.

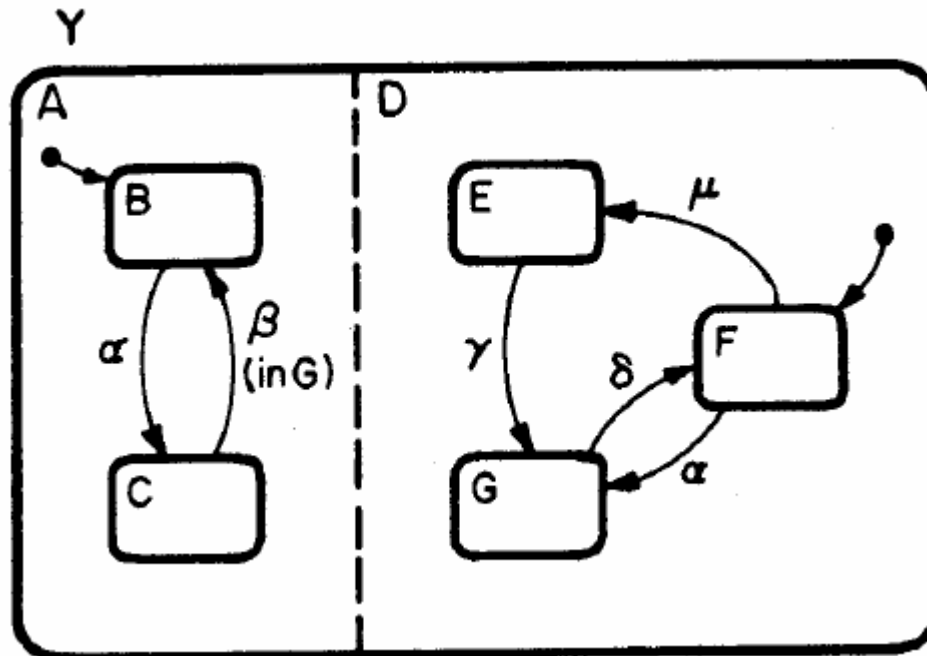

Figure 3.7: Statechart Orthogonality and Broadcast Communicability ^[17]

In this diagram, Harel shows that both state A AND D are happening at the same time while grouped within the superstate Y. Specific to orthogonality is the ability to model two systems occurring at the same time through the use of the dotted line separating the two pieces. Between these two systems, though, transitions within a state can occur both *independently* of the other state and *concurrently* with another state and so they are said to be orthogonal. For example, to model the independence of transitions, assume the system is currently in states B and F. If transition μ occurs, the new states are simply B and E. The transition in superstate D does not affect the superstate A.

Furthermore, concurrence of transitions can easily be modeled and also show the broadcast communicability of the statechart. If the system starts again in states B and F, then the transition α presents a simultaneous double shift. The broadcast communicability feature states that if in superstate A, we move to state C. In superstate D, F transitions over to state G because the design allows for some degree of communication between the states to enable the double shift to occur. This orthogonality is substantially more beneficial, Harel claims, when modeling even larger, more complex systems. He gives the following as an example of this with the same system just covered.

Figure 3.8 presents the simple orthogonality diagram discussed above except this time in state diagram format. At initial glance, the prospect of trying to follow all the states and arrows might be overwhelming. However, with diligence, it is seen that all states and transitions depicted in the above statechart are included in Figure 3.8, albeit in a more scattered manner. Harel indicates increased complexity further muddles the orthogonality of representing a system. He points out that “two components with one thousand states each would result in one *million* states in the product.”

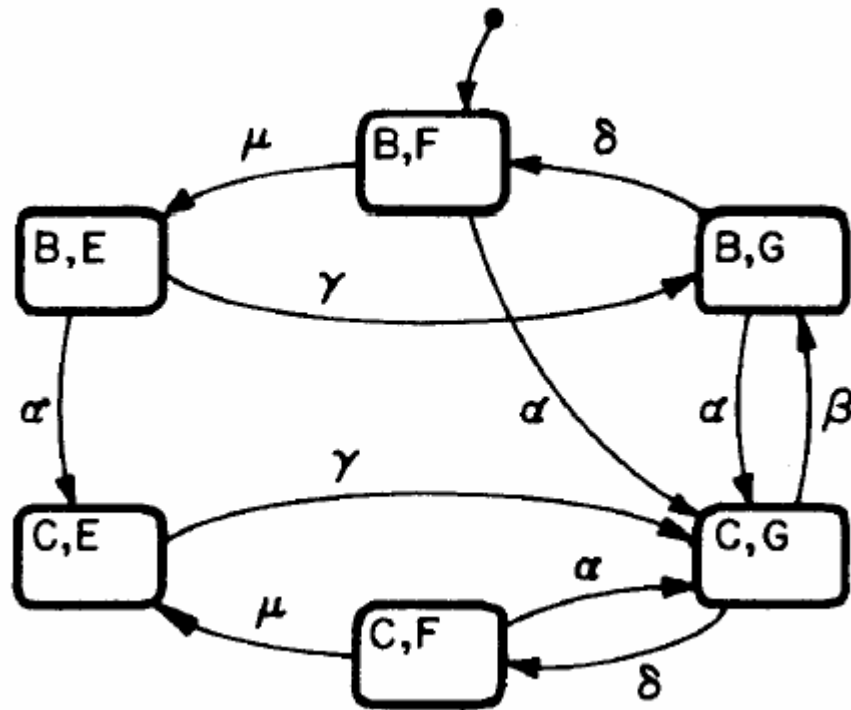

Figure 3.8: Orthogonality in State Diagrams^[17]

System Segmentation

An interesting aspect in using statecharts is the ability to easily separate the pieces of the system for development by different groups. Using our simple system as before in our depth example, the creation of a superstate D allows for better organization and presentation by segmenting the various states. We can show this additional statechart feature in referring back to our upright flying state, inverted flying state, and ejection state example. To show the ability of statecharts to be easily separated, we draw a parallel to how a research team could perform the division of labor necessary to build our aircraft.

If a company must design an aircraft in which these are the only three states that exist (upright, inverted, or ejecting), the statechart lends itself to easy task breakdown. If a specific team of engineers is tasked with the aerodynamic controls of the aircraft and must only determine the transition between states A and C , then their entire problem is shown in Figure 3.9.

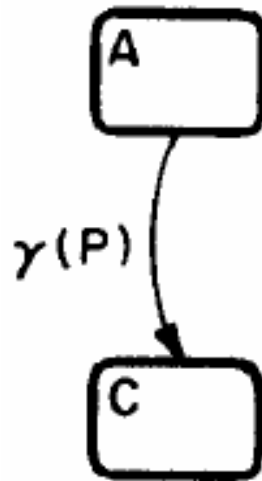

Figure 3.9: State D ^[17]

The engineers working on the problem of transitioning the aircraft from inverted flight, state A , to upright flight, state C , might determine that the conditional transition, $\gamma(P)$ equates to “significant aileron input effectively moving the aircraft to the upright position.” Irregardless of what they determine $\gamma(P)$ is, these engineers are unconcerned with how their problem fits into how the ejection system works. Higher level managers can easily broadcast this problem to the engineers without burdening them with the specifics of the rest of the system. The integration team, consequently, would be given a problem that resembles Figure 3.10. This team of engineers does not worry about how the aircraft goes from inverted to level flight only with how the system transitions from flying to ejecting, β , or back again, α or δ (resultant of a malfunction with the ejection system, for example). This key principle of abstraction is evident in this example and enables simplification of states and transitions among other things.

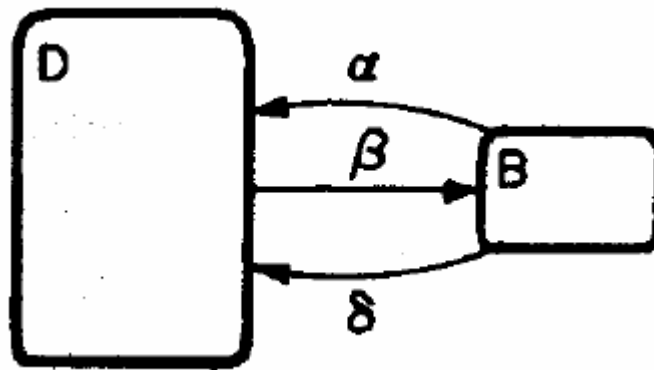

Figure 3.10: Integration Team Statechart ^[17]

With the state diagrams, the interaction with aerodynamic control would force all the different parties into the same room to understand jointly the full problem as seen below again in Figure 3.11. Both flight controls and systems integration would need to work together to design the system as seen with the state diagram.

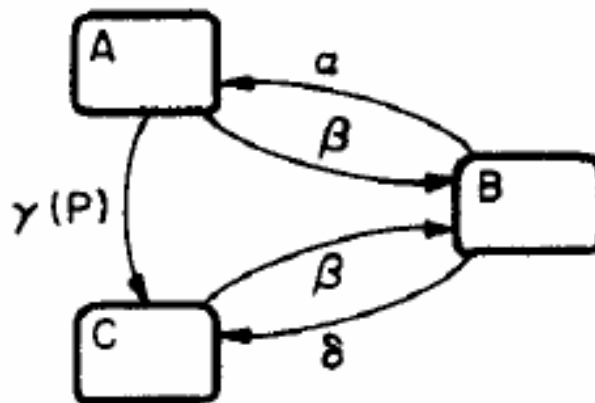

Figure 3.11: State Transition Diagram ^[17]

Representing Tactics

In evaluating the use of statecharts as a means to represent tactics, the decision is appealing for several reasons. The first is that tactics themselves are reactive by nature; the tactic employed by a helicopter pilot depends on a multitude of outside influences. At any given instance, his reactions to stimuli will dictate whether to increase his altitude at a specific point or maintain straight and level flight. As Harel states in his concluding section, “an essential element in the specification of reactive systems is the need for a clear and rigorous behavioral description” [17]. Harel makes his comment with regards to product development, yet we propose that statecharts will be effective in depicting the tactical behaviors of helicopters as they too must react to outside influences. Harel’s subsequent quote that statecharts present one manner to visualize reactive behaviors formally concurs with our opinion that statecharts could present a plausible option for depicting a vehicle’s behavior or tactic executed.

Statecharts are also being explored as a means to represent tactics for their ease with which to visualize behaviors. As seen in the discussion on orthogonality, representing more complex interactions is much easier with the statechart than the state diagram. Once the simplistic statechart “language” is understood, understanding the processes within the system is nearly as easy as following a basic flow diagram. In considering this, tactics themselves encompass a broad range of levels within a system, and statecharts present an opportunity to show the integration easily of both higher level planning tactics with lower level execution tactics. While this research is focusing solely on the tactics level presented in Chapter 2, if modeling tactics with statecharts is found advantageous, follow-on research could attempt to model events that occur in route planning, mission planning or resource allocation.

Finally, the most important reason for seeking out this type of visual formalism is that it has been proven to support our multi-pronged methodology that integrates feedback from diverse sources. Harel, in his practical experience with using statecharts, explains that his initial research in using this type of diagramming was born out of the development of a complex avionics system for the Israel Aircraft Industries. Statecharts, he claims, were especially effective in bringing in designers from many different backgrounds: pilots, engineers, software professionals, defense experts, etc. Harel articulates the statechart allowed various people to “enter” discussion of the system’s behavior with minimal effort to catch them up on previous discussions; it effectively allows multiple inputs to be assimilated into the design of how a particular behavior works. The proposed autonomous rotorcraft behaviors in this thesis, likewise will consider inputs from a similar wide range of sources: pilots, simulation designers, writers of field manuals, and actual simulation results. Likewise, in explaining the tactics described, it is feasible that an equally wide range of personnel could try and follow the behaviors described; the more aesthetically pleasing to view the tactics, the better chance they stand to be understood and integrated.

Why visualize at all?

At this stage, though, it is important to ask why use any type of visual representation be it a statechart, state transition diagram, or a simple flow chart? As seen in previous tactical development research, most research was done through the use of qualitative means. However, we argue the use of a visual medium is important for several reasons when compared to two alternatives.

One method considered for representing the events and transitions seen in tactics was through pseudocode, or a general outline of a code written entirely in English describing what events should occur. However, as an important aspect of the research entailed obtaining feedback from pilots and other subject matter experts who may or may not be familiar with computer programming, the ability to clearly convey what actually occurs during a tactic may be lost. Furthermore, as the complexity of a system increases, a first time viewer of a tactic in pseudocode will likely get confused while trying to follow the transitions between systems.

A second manner considered for describing tactics was by using text descriptions in paragraphs to outline the new autonomous rotorcraft tactics. The principle drawback to this approach, though, was the open interpretation of text writing when transferring it actually to code. The statechart in particular presents a 1 to 1 ratio of what occurs to what should be encoded; current software platforms can actually translate graphically designed statecharts into C, C++, and Java among other languages. Text descriptions, while easier to follow for the non-programmer than pseudocode, can easily be misinterpreted by the programmer especially if the military nomenclature written into the text is unfamiliar to the programmer.

In conclusion, the statechart represents an advantageous manner for attempting to translate the behaviors of an autonomous rotorcraft into quantifiable events suitable for software development. Just as an architect's blueprint allows the home buyer to get a basic understanding of the layout of their future home, a visual system allows both the customer and the developer to understand the essence of what the other wants *before* final production of a system.

3.5 Simulation

In this final piece of the methodology, we initially outline the rationale and use of simulation to test the development of autonomous rotorcraft tactics. Afterwards, we discuss the motivation in simulating with OneSAF to test the development of tactics and explain some its modifications particular to use in this thesis.

Methodology Incorporation

The decision to include simulation in the methodology considered several aspects in determining its effectiveness. As seen in the simulation papers presented in the literature review section, simulation allowed each of the research teams to *advance* hypothesized ideas. None of the researchers claimed their method was the end all of how to solve the problem they presented; each simply stated their simulation was one method to further their particular study of tactics. In following their example, the use of simulation in the development of these tactics simply proposes a manner to advance research in this field.

An initial reason we sought to include a simulation stemmed from seeking a manner to encode and test the statecharts developed. Live experimentation with actual rotorcraft is naturally the best choice but is usually impractical due to cost and schedule considerations. Simulation, though, serves as a viable alternative with which to validate the designed tactics.

Particular to this research, simulation also provides a key feedback component in the iterative spiral of the proposed methodology. Pilot feedback could have been selected as the only validation needed for claiming the tactics as suitable foundations for further research.

Through either the use of quantifiable surveys or qualitative assessments, the statecharts could have been validated by these means. However, after developing the tactics through field manual research, interviews, and outlay in a statechart, the simulation provides a more quantifiable manner of feedback on the feasibility and benefits of the proposed tactics. Just as pilots were able to examine the statecharts of each tactic and voice concerns or validation of the events and transitions, the simulation simply takes the tactics as executed and scores them according to survivability for the entities involved, which enabled a *small* degree of validation of the tactics. These results do not provide full accreditation; the very nature of tactics prevents unequivocal validation of a particular behavior. By this, we mean that the conditional factors influencing how a tactic are often so dynamic in warfare that a rubber stamped, 100% guaranteed tactic is infeasible.

In addition, simulation presented us with an important ability to look at *future* tactics. Current techniques, tactics and procedures are all based on existing capabilities, and pilots base their information of how maneuvers are performed at the present. With simulation, we are able to explore battles with capabilities that will likely materialize in the future while utilizing tactics that we imagine to be built into futuristic versions of unmanned rotorcraft.

OneSAF

After researching and realizing the benefits of simulation, the decision then became selecting a suitable one for the scope and purpose of this thesis. Possible explored options include an internal simulation developed within Draper Laboratory called Chayton. In addition, consideration was given to several simulations that model rotary wing operations with high levels of fidelity. These models are typically developed and used by defense corporations in support of their own simulation objectives. In the end, though, the OneSAF Testbed Baseline 2.0 (OTB 2.0) was selected for several appealing features supporting the aims of academic research.

The OneSAF Testbed Baseline is the successor of Modular SAF (ModSAF), which is the successor to the Simulator Networking (SIMNET) and (ODIN) Semi-Automated Forces (SAF) systems. Consequently, OTB 2.0 is the successor to OTB 1.0 and the final beta version before the release of the OneSAF Objective System (OOS) - the desired endproduct for much of Army simulation. Specifically, the OOS that OTB 2.0 supports “will be a composable, next generation computer generated forces (CGF) that can represent a full range of operations, systems, and control process from individual combatant and platform to battalion level, with a variable level of fidelity that supports all modeling and simulation domains. It will accurately and effectively represent specific activities of ground warfare (engagement and maneuver), Command, Control, Communications, Computers, and Intelligence, combat support, and combat service support. It will also employ appropriate representations of the physical environment and its effect on simulated activities and behaviors” [54]. OTB 2.0 can model different terrain, different branches of the armed forces from more than six countries, and the effects of weather on the behavior of entities within the simulation. The simulation is developed by Science Applications International Corporation (SAIC) out of Orlando, Florida and contains over 778 libraries totaling approximately 1.9 million software lines of code. When the OOS is completed in 2006, the lines of code are expected to grow to approximately 3.5 million [41]. Despite the size and aims of the OTB 2.0, several facets of the program made it valuable in the research of this thesis.

The first and most advantageous aspect of OneSAF was that its code was open source, thus giving any user the ability to view, modify, and possibly create behaviors for testing within

the program. (With the open source capability not available in other higher fidelity simulations, OneSAF enabled a dual learning objective of mastering a complex simulation tool.) Initially, the source code enabled viewing events and transitions within some tactics already programmed within the code. By tracing the execution of the program through a particular tactic, an understanding was developed for how the simulation modeled the manned tactics already within OneSAF. Furthermore, the open source nature made certain parameters of the program capable of being manipulated thus enabling some modifications outlined below. Finally, having the source code enabled the reprogramming of behaviors suitable to the execution of unmanned tactics while using manned programming tactics as a baseline.

Although lacking a level of fidelity compared to other helicopter simulations, OneSAF nevertheless presented several additional features that made it a suitable selection. To begin, the vehicle data contained within the program is validated by the US Army Materiel Systems Analysis Activity (AMSAA). AMSAA's certification added an element of realism to the modeling not contained in other simulations considered. Furthermore, OneSAF is supported by a community of users and developers through the OTB reflector email list. With this email list, answers to developing questions can be posed to the group thus enabling solutions from more experienced users. Finally, it is worth mentioning that despite all the features and support options within the program, the simulation itself can be obtained from developmental and research use at minimal cost to the user.

Modifications

Entity Creation

Using the steps outlined in the Developer Course Workbook, we built a new helicopter called the UAR entity intended to represent a generic, unmanned autonomous rotorcraft [52]. Although the purpose of this thesis was not to test different vehicle parameters, a new vehicle was built under the assumption that any program involving autonomous vehicles was likely to use smaller more agile parameters than currently possessed by the AH-64 Apache. The vehicle entity incorporated many of the stealth and radar signature capabilities of the RAH-66 Comanche helicopter that was already built in OTB 2.0; however, some considerations were based off specifications found through the public domain about both Lockheed Martin and Northrop Grumman's UCAR vehicles.

Specification Chart

	UCAR	UCAR
Developer	Northrop Grumman	Lockheed Martin
First Flight	2006	2006
Gross Weight	6,400 lbs.	5,800 lbs.
Empty Weight	4,600 lbs.	3,900 lbs.
Overall Length	36 ft.	38 ft.
Wingspan/ Rotor diameter	32 ft.	35 ft.
Weapons Payload	>500 lbs. (1,100 lbs. max. internal)	>500 lbs.
Ceiling	>20,000 ft.	>20,000 ft.
Cruise Speed	160 knots	>170 knots

Table 1: UCAR Vehicle Specifications ^[8]

Killer Victim Scorecard

As a means to compile data from each of the simulation runs, the Killer Victim Scoreboard (KVS) capability is an option within OneSAF. The decision to use this capability was based on papers published by Army Research Laboratories (ARL) that showed this capability as effective in “scoring” the results of a battle [37]. In their 2002 paper, Janet O’May and other researchers at ARL effectively designed full scale tank engagements that graded battles based on various engagement criteria. Data parsed from each of their engagements included many different parameters to include the firer’s position, the target position, the projectile used in each attack and the kill thermometer within OneSAF based on, among other things, the projectile, the range of the projectile, and the angle with which the projectile hit.

For the purpose of this thesis, though, the Killer Victim Scorecard was modified by means of the open source nature of OneSAF. By manipulating the source file, the only data pulled out of each scenario was simply the survivability statistics defined as follows. In each scenario, if a vehicle was effectively engaged once by an enemy force, whether as a catastrophic, firepower, mobility or firepower and mobility kill, the modified KVS simply reported out the vehicle’s four digit code and a value of “1” to represent the vehicle was hit. The code was further modified to only allow an entity to show up once a scenario as having not survived. The vehicle was identified according to its four digit code by use of the vehicle tracker capability left unmodified within OneSAF that paired vehicle codes to airframes.

The decision to use only survivability scores despite the volume of data that could be collected stemmed from seeking to simplify the effectiveness of proposed autonomous tactics. Although OneSAF is considered a fairly high-fidelity simulation, the scope of this thesis

prevented a full-scale simulation analysis of multiple tactics in multiple scenarios in which advanced data gathering would be necessary.

Monte Carlo Simulation Runs

Another aspect modified within OneSAF involved setting the simulation up for multiple iterations in order to perform Monte Carlo runs. Help from Maryann Matyola at the US Armament Research Development and Engineering Center (ARDEC) in Picatinny, New Jersey, was instrumental in getting this capability working. Modifications were initially made to both the main.h file and the main.c file within the OTBSAF directory. Then using a file created by the team at ARDEC, a batch shell scripting file was modified in order to execute the necessary options needed for simulation runs. In addition to modifying these options, a line was added to the shell script file that wrote the simulation number run to the same file the Killer Victim Scorecard output was being written to. This slight change enabled data to be collected based on the simulation run, thus enabling analysis of each vehicle's survivability in the scenarios. All scenarios were run fifty times in order to get a broad estimate of the different tactics effectiveness from the baseline to the tactical scenarios.

Free Firing Rules of Engagement

To add realism to all the engagements, the source files controlling the rules of engagement (ROE) were modified. All scenarios were run with the assumption that all vehicles would fire immediately upon sighting enemy forces; no vehicles were instructed to fire only if fired upon.

In this section, we have explored the methodology used to formulate autonomous rotorcraft tactics. We have described each aspect of the converging spiral in detail; field manuals, subject matter experts, statecharts, and simulation were each covered to show their importance and relevance in developing behaviors. In the following chapter, we use this design to develop and test six specific tactics potentially advantageous in future rotorcraft missions.

[This Page Intentionally Left Blank]

Chapter 4 Single-Vehicle Autonomous

Rotorcraft Tactics

In this section, we describe, outline, simulate and discuss six single vehicle tactics recommended for inclusion in autonomous rotorcraft planning. In using the three-pronged methodology discussed in the previous chapter, each tactic is covered in its entirety before discussing the next tactic. Initially, we pull research gleaned from field manuals and from interviews with the SMEs to explain background information pertinent to the tactic and necessary to understand the premise of its statechart. In doing this, we also highlight situations, scenarios or capabilities that prove the tactic advantageous and adaptable for an autonomous rotorcraft. After this background explanation, we present the statechart which models the reactive events in the tactic's automation followed by an explanation of key states and transitions.

In incorporating the last piece of the methodology, each tactic is modeled in a basic scenario in the OneSAF simulation. Initially, we run a baseline simulation that represents one manner in which the tactic is executed by manned assets. Then, the improved upon tactic as seen in the statechart is modeled and run against the same enemies in the tactic scenario. The results of the tactic simulation are compared against the baseline simulation for vehicle survivability scores, and preliminary conclusions are made on whether the improved tactic is advantageous in an autonomous rotorcraft. Finally, each section concludes with a discussion of the results and analysis of the methodology's effectiveness in developing the tactic.

4.1 Running Fire Attack

Of the six tactics developed for recommendation, three involve attack techniques that could be aided by the maneuverability and risk-adverse aspects of a nimble, autonomous rotorcraft. The running fire attack, popup fire attack, and manned/unmanned lasing tactics are attack procedures currently employed by Army helicopters. In background discussion particular to these three tactics, the purpose centers on explaining the tactic as performed by manned platforms to aid in our development of the tactic in an autonomous vehicle. As expounded upon in each tactic, we support our assumption that these are three advantageous ways an autonomous rotorcraft should engage enemy forces.

Background and Purpose

Fundamentally, the "running fire" moniker accurately describes the premise of this tactic. In contrast to firing weapons from a stationary position, running fire involves the helicopter in a nose-low attitude releasing munitions, most commonly while flying in the direction of the entity

being targeted. While it is possible for the tactic to be executed when flying backwards or even sideways, for the purpose of this thesis we assume forward movement when accomplishing running fire.

To visually understand running fire, the following graphic depicts a subset or a type of running fire known as diving fire. The tactic is different in that it has the vehicle entering a shallow dive while performing running fire; nevertheless the picture's value lies in showing the helicopter flying in the forward direction while releasing munitions.

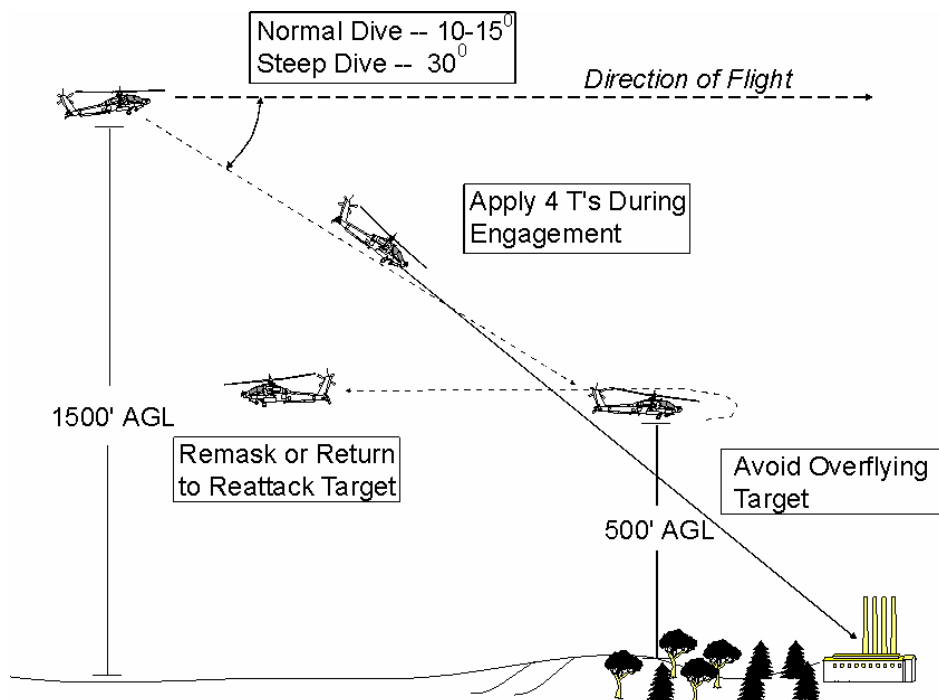

Figure 4.1: Diving Fire ^[21]

According to the AH-64D Longbow Apache Aircrew Training Manual, running fire is “an effective weapons delivery technique to use during terrain flight, especially in regions of the world where cover, concealment, and environmental conditions hamper or limit stationary weapons delivery.” [18]. In analyzing this definition, the description outlines several key areas of the tactic, and where its use is advantageous. To begin, terrain flight is defined as “the tactic of using terrain, vegetation, and manmade objects to mask the aircraft from enemy visual, optical, electronic, and thermal detection systems.” [42] Simply put, terrain flight involves flying incredibly close to the earth to minimize your presence as a possible target for enemy fire. More important in the definition is the various situations in which stationary weapons delivery is limited, thus prompting the running fire tactic.

When tasked with an offensive mission, attack helicopters typically seek to engage enemies at a maximum standoff distance in which the technology of their munitions gives them a significant advantage. Correspondingly, the tactic of choice for aviators is hovering fire as this technique enables aviators to deliver munitions accurately while remaining outside an enemy's effective engagement range. As seen in the Aircrew Training Manual, the running fire tactic is needed amid circumstances that prevent stationary weapons delivery. Of all the circumstances

that hinder a pilot's first choice in tactics, terrain most often is responsible for forcing the use of running fire.

In engagements with exceedingly flat terrain, running fire is often used for optimal weapons delivery as a dearth of hiding positions prevent the proper concealment needed to initiate a hovering attack. As flat terrain enables line of sight (LOS) from enemy to helicopter, pilots are left with hoping the range of their maximum stand-off weapon is greater than the range of the enemy air defense system in use. Without proper concealment while within the enemy's range, a pilot attempting to hover is significantly more vulnerable to improved enemy targeting accuracy. The most notorious flat section is desert, and recently the United States has fought both the Persian Gulf War and Operation Iraqi Freedom across large expanses of sand. In each, running fire has been utilized as an effective attack tactic.

In addition to desert terrain, the urban engagement is the second most significant terrain classification that has forced the use of the running fire tactic. With the proliferation of highly maneuverable, yet extremely dangerous weapons such as the Rocket Propelled Grenade (RPG) and the SA-18 MANPADS (Man Portable Air Defense System), operations in cities have become the most hazardous to pilots among current assignments. Insight from one pilot's experience in Operation Iraqi Freedom explains the increasing importance of running fire over urban terrain.

Captain Kevin Myers was a company commander of Apaches in Iraq from February 2003 to February 2004. When discussing the current use of firing tactics, Captain Myers stated the decision to use popup fire or use running fire is influenced by a myriad of factors. He said, however, that while in command in Iraq, the circumstances present there forced him to command to his pilots to use running fire. Over both cities and desert, Captain Myers cited that due to the proliferation and use of small arms, stationary helicopters became sitting ducks. Specifically, Captain Myers ordered his men that while flying "to keep moving, be unpredictable, and hover only if absolutely necessary - and at that only do it for a couple of seconds at a time." [35] His insights were spoken specifically to Iraq, yet a terrain-induced need to use running fire is applicable to another recent engagement with markedly different topography.

Operation Enduring Freedom became another engagement in which running fire was frequently employed. In Afghanistan, though, the necessity to employ running fire arose more out of the principles of aerodynamic flight than the enemy conditions faced. At higher altitudes, air density is much lower, making it more difficult to generate the necessary lift for a helicopter. As the amount of lift generated must meet or exceed the load being carried in order to maintain a hover, helicopter pilots were forced to either reduce the load in their airframe or alter their tactics. However, as no pilot relishes the opportunity to fight without a full complement of weapons, pilots changed their tactics to execute running fires as this tactic requires less power and lift since the airframe is never held in a constant position. [10] In Afghanistan, the mountainous terrain and low air density made hovering difficult; correspondingly, running fire became more advantageous to execute.

The final scenario in which running fire tactic is preferred involves close in operations in which the minimum arming distance for long-range, precision guided munitions cannot be achieved. In these "knife-fight" type engagements, the Apache gunner must instead rely on the 30 mm cannon or rockets to fire upon the targets. In many cases, these engagements are the result of an unexpected pop-up threat that forces the pilot to lay suppressive fire while attempting to maneuver out of enemy's effective range. At other times, these close distance encounters occur in support of advancing ground troops engaged with enemy forces.

Statechart

The below statechart depicts the states and transitions synonymous with a UAR vehicle executing a running fire attack on a pre-determined target. The context for initiating this tactic is that a UAR has already been cleared by the human in the loop to fire based on intelligence it has received. Whether the clearance for commencing the attack is given by an Apache pilot controlling the aircraft or an AWACS aircraft, the statechart assumes authorization to fire before the vehicle enters into the autonomous execution of the states and transitions as depicted.

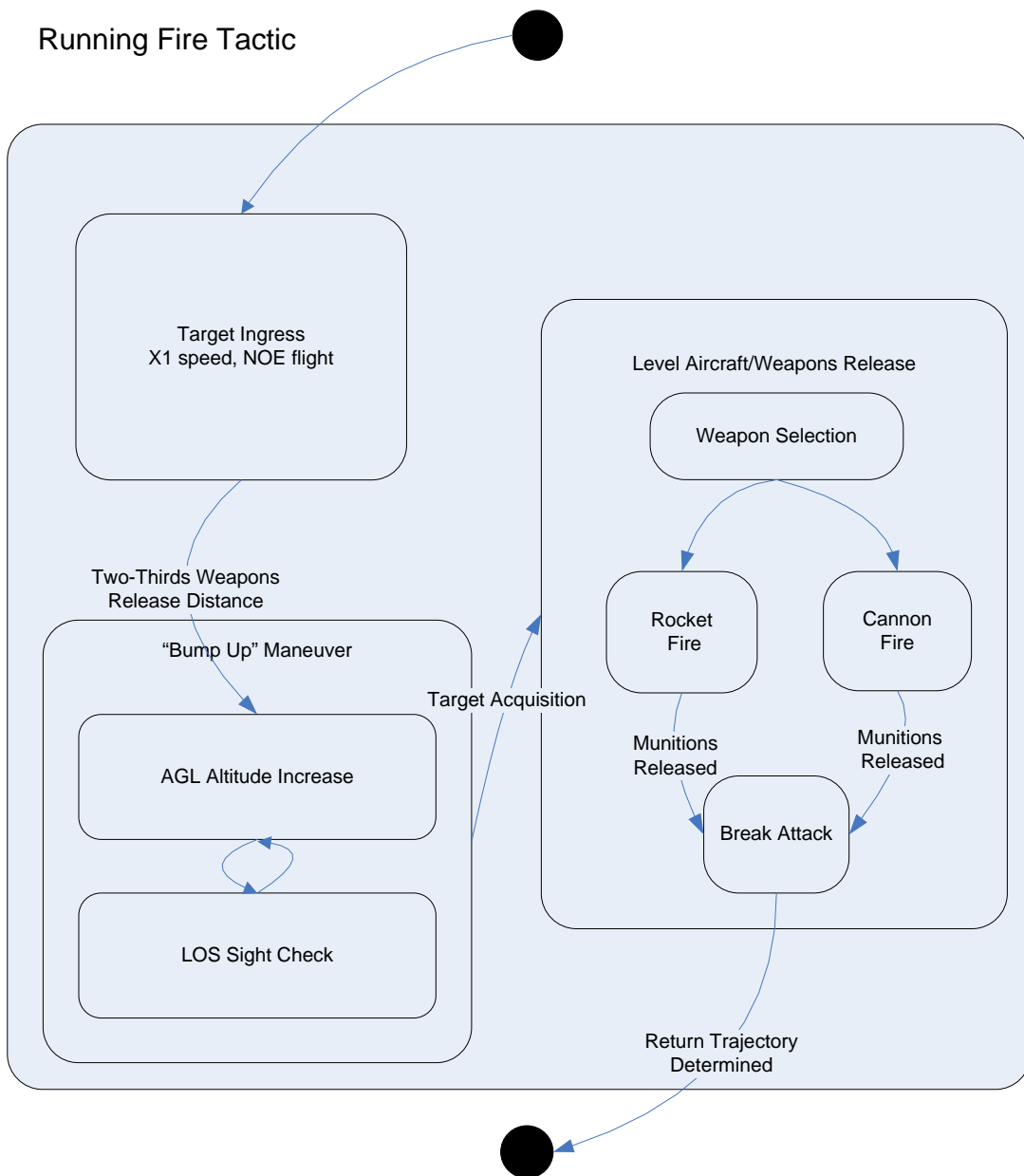

Figure 4.2: Statechart for Running Fire Tactic

Upon initiation of the running fire tactic, the first state entered is that of target ingress at Nap of the Earth (NOE) flight. With this ingress, the imagined scenario involves bringing the UAR within range of its non-precision guided munitions (cannons and rockets). The speed is labeled a variable, X_1 , to indicate a maximum achievable speed based on the algorithms used by the vehicle's trajectory generation to maintain NOE flight. The helicopter utilizes NOE flight for maximum survivability while using concealment and masking to ingress the target area undetected. While higher flight profiles may permit higher speeds during the ingress, terrain following flight is recommended to maximize survivability.

At approximately two-thirds of the intended weapon's maximum effective range, the tactic transitions to a bump-up maneuver. The determination of using the two-thirds distance is based off literature and recommendations from the Army that indicate optimal targeting and weapons effectiveness at approximately two-thirds of the weapons maximum range. As executed and interpreted in the field, though, Captain Myers indicated that the "two-thirds rule" is seen as advice rather than explicit instructions. According to Captain Myers, "the two-thirds rule is more guidance than a hard-rule. It simply means that based on the munition you intend to release, firing at the two-thirds distance makes you more survivable while still maximizing your effectiveness." However, Captain Myers then proceeded with evidence that the distance with some weapons runs counter to proven field experience. He stated "that in the instance of the 30 mm gun [on the Apache], 3700 meters is the maximum effective range, which roughly places you at 2400 meters to adhere to the two-thirds rule. However, field training and experience tells you that 1500 meters is more the optimal distance for the gun in order to achieve maximum lethality." As seen in Captain Myers example, the two-thirds rule is guidance, but in attempting to automate transitions between states, it is harmonious with Army doctrine and survivability recommendations.

After target ingress, the next state transitioned into is the Bump Up Maneuver, or more simply referred to as "the bump." In this state, the rotorcraft will slowly increase its altitude until line of sight is achieved with the enemy. Upon target sighting, the aircraft will level itself, or initiate a shallow dive, to set up stability for weapons release. After target acquisition, and with prior clearance to fire at the target, the aircraft then proceeds into the weapons release state. Based on recommendations found in field manuals and Table 2 found below, the UAR should plan on release of rockets from a distance of no greater than five kilometers and cannon fire no greater than approximately one and a half kilometers [21]. Furthermore, for optimality of targeting, the autonomous vehicle should not release rockets closer than 3000 meters or cannon fire closer than 1000 meters.

Table 2: AH-64 Day Engagement Evaluation Table ^[21]

TABLE III. DAY AH-64 COMMANDER'S EVALUATION TABLE (PILOT)						
TASK		CONDITION			STANDARD	
NO	DESCRIPTION	MODE	RANGE	TARGET	TGT EFFECT	AMMO
1	ENGAGE STATIONARY TARGET W/ROCKETS	HOVER	<3000m	LIGHT ARMOR	2 RKTS IN 300 X 400m TEA	6 RKTS M274
2	ENGAGE STATIONARY TARGET W/HELLFIRE	HOVER	>4000m	HEAVY ARMOR	HIT	1 HELLFIRE
3	ENGAGE MOVING TARGET W/CANNON	HOVER	1000-1500m	WHEELED VEHICLE	HIT	30 RNDS
4	ENGAGE STATIONARY TARGET W/ROCKETS	HOVER	>4000m	WHEELED VEHICLE	2 RKTS IN 300 X 400m TEA	6 RKTS M274
5	ENGAGE STATIONARY TARGET W/HELLFIRE	MOVING/ RUNNING	2000-4000m	HEAVY ARMOR	HIT	1 HELLFIRE
6	ENGAGE STATIONARY TARGET W/CANNON	MOVING/ RUNNING	<1000m	LIGHT ARMOR	HIT	30 RNDS
7	ENGAGE STATIONARY TARGET W/HELLFIRE	HOVER	2000- 4000m	HEAVY ARMOR	HIT	1 HELLFIRE
8	ENGAGE STATIONARY TARGET W/CANNON	HOVER	<1000m	WHEELED VEHICLE	HIT	40 RNDS
9	ENGAGE MOVING TARGET W/HELLFIRE	MOVING/ RUNNING	<2000m	HEAVY ARMOR	HIT	1 HELLFIRE
10	ENGAGE STATIONARY TARGET W/ROCKETS	HOVER	3000- 4000m	LIGHT ARMOR	2 RKTS IN 300 X 400m TEA	6 RKTS M274

NOTES:
1. Table III is designed for use by unit IP/SP to determine individual proficiency and readiness level.
2. All rocket engagements will be fired as pairs.
3. Table is not resourced IAW DA PAM 350-38. Conduct in the CMS.

Finally, it is noted in Field Manual FM-114 that when manned helicopters use this tactic that “crews should not over fly the target area.” This warning is equally applicable to unmanned assets in order to improve survivability. After weapons release, the aircraft should initiate a break from the attack optimally using a trajectory similar to threat avoidance in order to minimize vulnerability. Finally, the aircraft should plan this break from the target so that its return route takes the vehicle back towards the initial ingress point. By doing so, the vehicle flies over terrain already cleared for enemies while setting itself up for an additional run towards the target should some enemies remain.

Scenarios

The scenarios designed for testing the running fire pitted a single UAR vehicle against a single Russian SA-8 Gecko air defense system. The SA-8 was selected as the enemy as the short range, mobile, surface to air missile (SAM) launcher presents a defense that is especially lethal against rotorcraft.



Figure 4.3: SA-8 SAM Launcher

The baseline scenario run in the simulation replicated the manner in which a manned asset could conduct running fire. As survivability is decreased with higher altitudes, it is possible a manned asset would have hesitancy with performing the bump up maneuver as the maneuver calls for an altitude increase to sight the target which correspondingly makes the vehicle more vulnerable. Therefore as the bump up is more dangerous, this translates into a possible tactical advantage of using an autonomous rotorcraft. If a target is deemed high value enough for the UAR to be seen as expendable, this represents a tactics advantage over a manned asset.

With these considerations, the baseline scenario entailed the rotorcraft flying a constant NOE altitude towards the SA-8. The tactical scenario, consequently, depicted a bump maneuver executed approximately 1.5 kilometers away from the target. As seen in the Figure 4.4 screen shot of the UAR executing the autonomous maneuver, the altitude of the UAR is across the bottom showing it to be bumping up to 16 meters while having visually acquired the SA-8 in the figure (depicted with a red dotted line surrounding a white box to indicate the UAR has sighted it).

Based on the scenarios tested, it is expected the UAR and SA-8 will experience higher survivability scores in the baseline scenario. As the rotorcraft maintains NOE flight towards the SA-8, LOS will likely not be established thus preventing weapons for either of the entities to lock on to the other. For the tactical scenario involving the rotorcraft's increase in altitude, we expect the survivability scores for both entities to be much lower. It is possible for one vehicle to sight the other first and thus get the first shot leading to lopsided engagements. However, both

vehicles could sight each other at the same time, in which case there could be an even distribution of survivability for which entity is hit in each engagement.

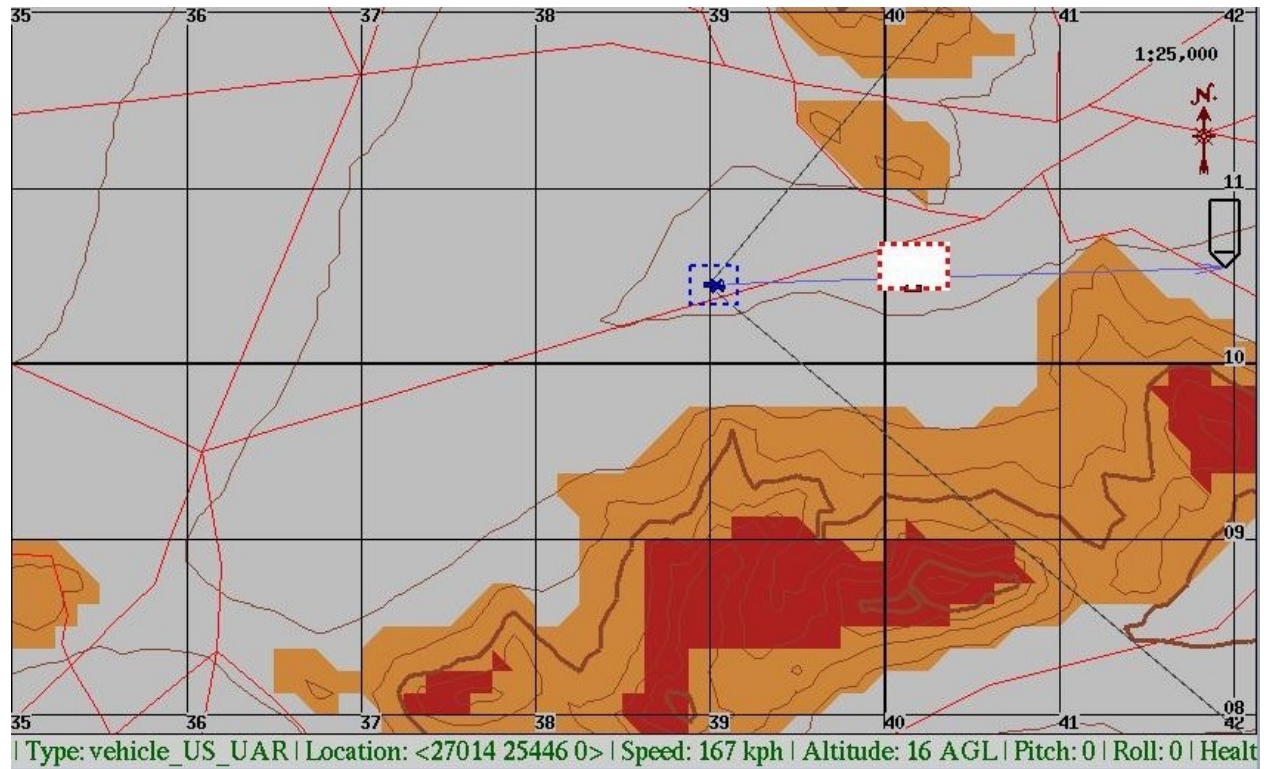

Figure 4.4: Running Fire Screenshot

Results & Analysis

The results of the scenario runs demonstrate a limited effectiveness in an autonomous rotorcraft executing the more dangerous tactic of including a bump up maneuver while performing the running fire. The baseline scenario results depict the expected outcome of the Monte Carlo runs; the rotorcraft was neutralized on four occasions in the experiments while the SA-8 was only targeted once in the fifty simulation runs. This is comparable to our hypothesis showing NOE flight limiting line of sight between both entities thus preventing effective targeting.

Running Fire

Type Baseline
Scenario Name RFBaselineTwo.1.gz
Run Date 3/14/2005
Scenario Runs 50

Vehicles:

Blue	Red
1002 UAR	1001 SA-8

Vehicle ID	Data			Survivability
	Type	Team	# Losses	
1002	UAR	B	4	92.0
1001	SA-8	R	1	98.0

Table 3: Running Fire Baseline Results

The tactical scenario results indicate a mixed effectiveness of performing the bump up maneuver with the autonomous vehicle. The survivability of the red SA-8 decreased drastically with the tactic; however, the UAR vehicle's survivability also decreased significantly, albeit on a smaller scale. The conclusion of this research points to further development of including a bump up maneuver in the execution of a running fire attack. However, as will be stated with the simulation of all tactics, these results represent only a very small subset of the possible outcomes to occur with an autonomous vehicle executing one of the unmanned tactics.

Running Fire

Type Tactic
Scenario Name RFTacticSeven.1.gz
Run Date 3/14/2005
Scenario Runs 50

Vehicles:

Blue	Red
1002 UAR	1001 SA-8

Vehicle ID	Data			Survivability
	Type	Team	# Losses	
1002	UAR	B	28	44.0
1001	SA-8	R	34	32.0

Table 4: Running Fire Tactical Results

Analysis

In analyzing the methodology used to formulate the tactic, field manuals and literature on current engagements were particularly beneficial in outlining the basic premise of the target as currently executed. Both FM 1-140 and TC 1-251 presented slightly different techniques for executing the tactic for manned platforms and by combining different aspects of these two recommendations, we formulated the tactic's statechart. In addition, the SME interviews provided insight into the Army's justified worry over fratricide, or the incident of friendly forces accidentally killing friendly forces. With the running fire attack, typically it is employed in closer engagements, in which case US ground troops stand a greater chance of being in the vicinity of the enemy. Particular to this tactic, the avoidance of fratricide could be a possible roadblock; as Captain Myers explained it, "if you're not 100% sure [of not hitting friendly forces], then don't pull the trigger. Finally, with the design of the statechart, a consideration eventually left out was having the UAR enter a shallow dive after sighting the target in order to improve weapons effectiveness. However, as the transition to weapons release is intended to occur once LOS is spotted, a shallow dive could break the LOS needed for targeting. As it stands now, it could happen that the initial altitude "bumped up" to is broken after the aircraft has leveled; however, this occurrence would occur less frequently than if a shallow dive is executed. Furthermore, bumping the aircraft up to a higher altitude than initially needed for LOS acquisition would excessively decrease the survivability of the rotorcraft.

4.2 Popup Fire / Hovering Attack

The second attack tactic explored is popup or hovering fire. Whereas running fire is characterized by the forward movement of the helicopter in attacking the enemy, hovering fire is just the opposite. There exists several differences between the two tactics and the pretenses for using it, however, popup fire, like running fire, is important to develop as an autonomous tactic in order to show the two basic maneuver tactics in attack engagements.

Background and Purpose

According to the Helicopter Gunnery Field Manual, hover fire is “fire delivered when the helicopter is below effective translational lift, either in ground effect or out of ground effect. It may be stationary or moving, but movement during hover fire is always below ETL [Effective Translational Lift] airspeed” [21]. Simply put, hovering fire involves firing from a hover. A basic diagram of this tactic can be seen in Figure 4.5. Furthermore, for the purposes of this thesis, hovering fire and the term popup fire are used interchangeably to describe the tactic in this section. It is assumed that in using these two words interchangeably that a rotorcraft, whether autonomous or manned, is concealing itself prior to popping up and hovering to prevent line of sight from the enemy to the aircraft.

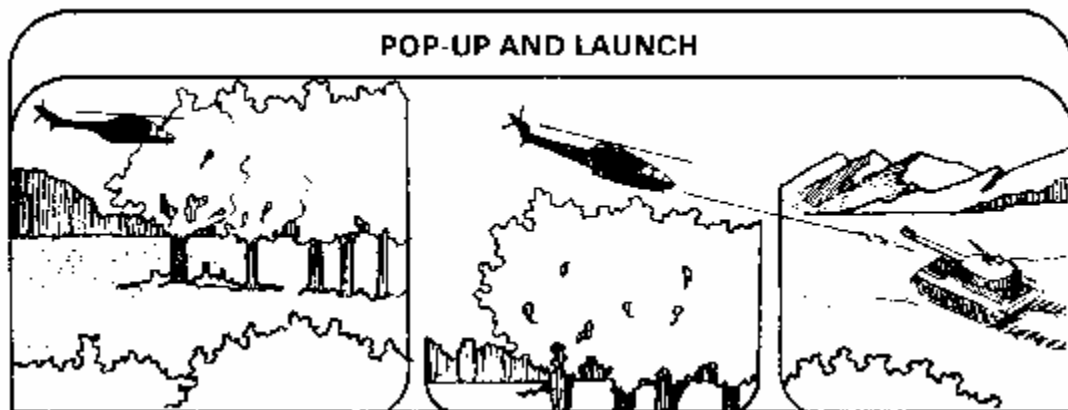

Figure 4.5: Popup Attack

CW4 Mike Wells, an Army Warrant Officer and AH-64A pilot, described the tactic saying, “hover fire was designed for standoff operations outside the enemy’s weapons capabilities and is designed to operate from within your safe area. It is better for optics, its more stable, and often is better for the accuracy of your weapons. And it is more simple - you just pop up, use your long range sensors and weapons, and leave” [65]. As simple as this may seem, though, the technique is complicated by specific considerations that must be taken into account when utilizing the tactic.

For the purpose of aerial gunnery, the key benefit of a hovering fire attack is the ease for inexperienced aircrews to be accurate and effective when using precision guided munitions. In the case of firing a Hellfire from an Apache, the difficulty of being accurate increases when you

must effectively sight your target while moving. This task becomes even thornier if your target starts to move. To put it in perspective, a synonymous analogy in executing a popup fire attack is that of trying to throw a football through a tire. Even with the tire stationary, this task is difficult, especially if you throw the football from several kilometers away. Correspondingly, if the tire (the target) starts moving, the task of focusing your senses (keeping an accurate laze) on the tire for timing purposes becomes that much more difficult. Finally imagine the tire throwing an explosive-tipped football back at you and this describes the “ease” of a hovering fire attack. The running fire attack, as discussed in the previous section, would be synonymous with running *at* the tire while throwing the football, which with short distance throws, is sometimes easier.

For non-precision guided munitions, firing accuracy from a hover position is more difficult due to the disrupted air flow, known as rotor wash, coming down off the rotating blades. In a running fire attack, the rotor wash is swept behind the aircraft whereas in a hover, the rotor wash comes directly over the munitions rack. In talking more with CW4 Mike Wells, for smaller munitions such as the aerial rockets or cannons, the rotor wash greatly disrupts the trajectory. This disturbance compounds the problem by forcing the pilot to sight the difference between the munitions intended destination and where the weapons are actually landing. While this delay from establishing an accurate correction measure is minimal, it nevertheless means that initial fires are not as accurate and therefore precise targeting is delayed. As an example of what is meant by rotor wash, a pictorial example of rotor wash can be seen in the following graphic of a helicopter hovering over water.



Figure 4.6: Rotor Wash Effects over Water

Another key consideration while executing hovering fire is getting the lift needed for the helicopter to hover in hotter environmental conditions. Just as a running fire tactic was often utilized in the mountains of Afghanistan due to the “thin” air, the heat found in Iraq and the corresponding density altitude have often made hovering infeasible. The Helicopter Gunnery field manual discusses this specifically by stating that “depending on the environmental

conditions, many aircraft hover OGE [Out of Ground Effect] very near their maximum torque available limit. The narrow power margin held by a loaded aircraft makes smooth, deliberate pilot inputs critical” [21]. In addition to mountains and urban terrain constraining an aircrew’s ability to hover, daytime heat conditions in the Middle East have caused an evolution away from this tactic.

Furthermore, recent engagements might suggest the stationary, hovering fire tactic is antiquated. Captain Myers stated that during his flying training in the Apache, the hovering fire tactic was predominantly taught, in what he considers to be a hold over in Cold War thinking [35]. According to him, the hovering fire tactic would have been great in “rolling across the plains of Europe” while engaging Russian tanks using the standoff capabilities of the Longbow and Hellfire missile system. However, his comments in the previous tactic about the use of running fire in Iraq support the notion of hovering fire being outdated.

In the previous Iraq war, though, the tactic *was* useful while fighting across the stretched deserts of Iraq. The initial attack by coalition forces was by Apaches using Hellfire missiles to engage and destroy radar sites at a standoff distance; Apaches also targeted tanks successfully in that war in standoff engagements. However, CW4 Terry Gibson, a Kiowa Warrior pilot stationed at Fort Rucker, summed up current thinking by saying “hover fire is good if you know the area is secure. But nowadays [referring to Iraq], when you’re over some terrain you never know if the area behind you is clear” [15].

The urban battlefield now seen in Iraq may make it seem the hovering fire tactic is not pertinent to future employment for manned assets, much less for an autonomous agent. Nevertheless, one key argument makes it pertinent to develop this tactic for programming into autonomous rotorcraft. The first lies in the increased danger in using running fire. Despite being unmanned, the survivability of an autonomous rotorcraft must be paramount in planning its use. The running fire tactic then is inherently more dangerous as it typically brings the vehicle at a closer range to its enemy. The impact on morale of losing an autonomous machine is acceptable when compared to losing a pilot’s life; however, the long-term, indirect consequences of lost reconnaissance and poor intelligence could be more detrimental to a unit’s success. While it is tolerable to lose an unmanned rotorcraft, they should not be considered easily expendable.

Statechart

Based on the considerations mentioned above in conjunction with feedback received from SMEs, we present the second statechart in Figure 4.8 showing the events and transitions that might occur in an autonomous rotorcraft’s execution of the pop up fire attack.

The initial stage for the execution of the popup fire tactic is selection of an ABF, or Attack by Fire, position. The primary purpose of the ABF position is to provide an initial point from which the rest of the tactic, the popup, will be executed. Manned assets selecting the attack by fire position evaluate many things, but ultimately the biggest consideration is whether or not the position properly masks the airframe from enemy targeting. For an unmanned system, this consideration is equally important; for the tactic to be effective as displayed in the statechart, any position selected must offer concealment to the unmanned asset. Once the ABF position is selected and the UAR vehicle situated in it, an autonomous vehicle must determine if it is properly masked through use of its own radars and sensors, and if it is, continue on to the next state.

After the transition, the UAR will then determine the optimal direction to unmask. While the a possible expectation is for the vehicle to always rise up, the Apache Aircrew Training Manual indicates that vertical unmasking is not required. According to the manual in describing the process, “unmask the aircraft, or FCR/RFI sensor [sensors particular to the Longbow Apache], by either lateral or vertical means and select a minimum safe altitude that provides for minimum exposure while allowing sufficient altitude for lateral and directional movement” [59]. In certain terrain situations it could be quicker to remask in the lateral direction after weapons launch. The decision of which direction to unmask, whether laterally or vertically, is determined by a calculation within the vehicle that finds the shortest estimated direction from its present concealed position that unmasks line of sight.

In the next event, the UAR must wait on a key transition before initiating the actual attack phase of the tactic. Unlike the running fire tactic, where human clearance into the statechart was granted in advance, the hovering fire tactic requires that clearance be given only after the vehicle has been situated in its ABF position. This design is intended to allow last minute cancellation of the attack in case the chance of collateral damage has become too great, or the target is no longer deemed a priority.

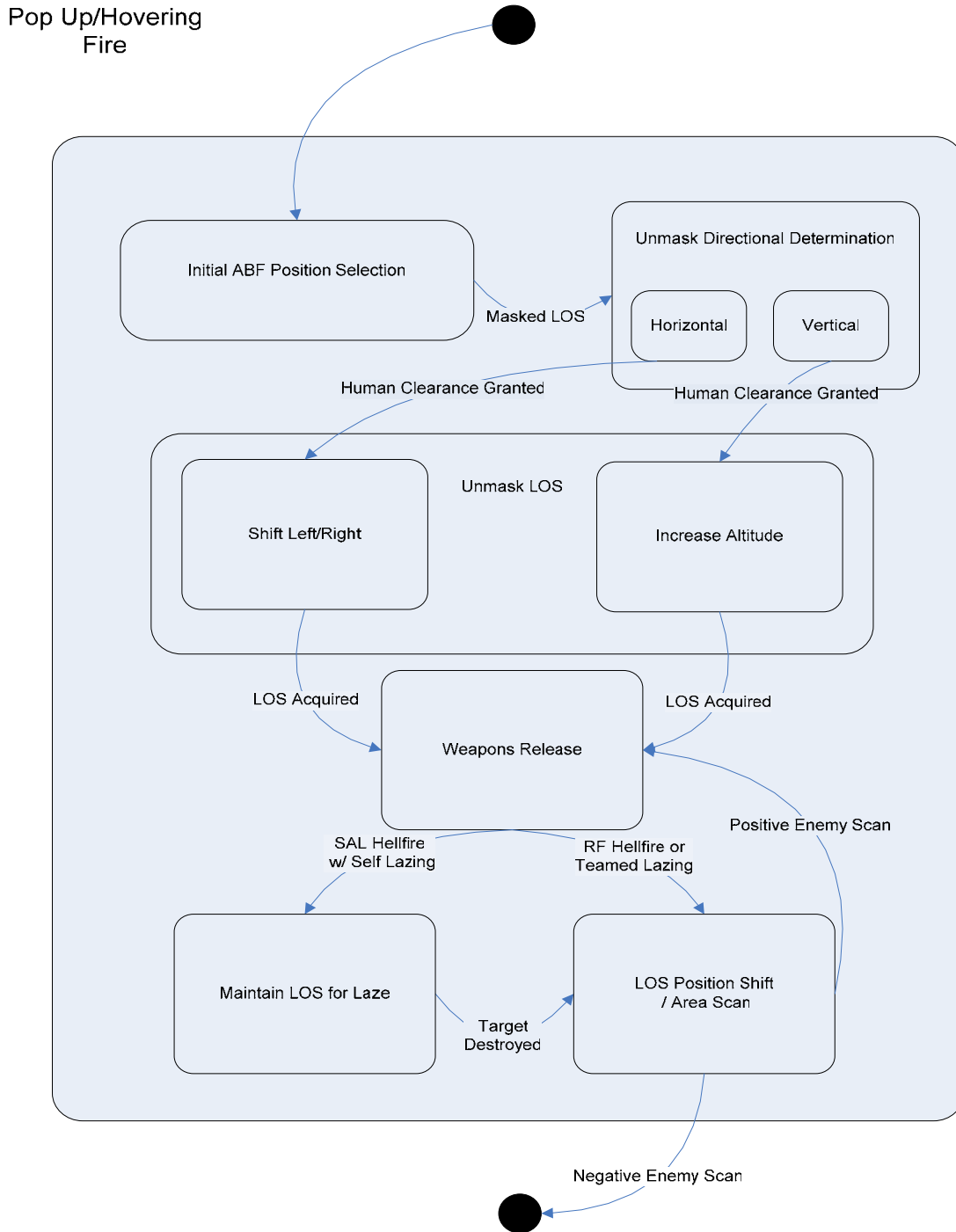

Figure 4.7: Hovering Fire Statechart

After the UAR has been cleared to attack the target, the next step is to follow the pre-determined flight path (either horizontal or vertical) until the aircraft has achieved LOS with the enemy. As seen in the statechart, depending on the determination of which way to unmask, the UAR either shifts to the left or right or raises its altitude. The transition out of this event occurs once LOS is established; at this juncture, the rotorcraft should immediately stop shifting or rising in altitude so as not to silhouette itself against the sky and needlessly expose itself.

The weapons release state is next which prompts different transitions based on developing technologies. The actual weapon released would be determined by computers or a human in the loop factoring a myriad of things to include the entity targeted, range and on-board munitions. Based on current munitions, though, the probable choice would be the Hellfire missile system. The Hellfire missile comes in two general variants and in many cases, either would effectively neutralize the target. However, depending on which is fired, this affects the vehicles actions. If the UAR is equipped with Fire Control Radar (FCR) and could use the RF Hellfire, the autonomous rotorcraft would be able to quickly transition to the next state due to the missile's "fire and forget" capability. If the Semi-Active Laser (SAL) Hellfire variant is fired, then the vehicle must either laze the target itself or allow another designator to control the missile's trajectory by shining the laser.

Once the SAL Hellfire has been designated to its target or the RF Hellfire released, the next state is the primary deviation from manned tactics for an unmanned aircraft. After weapons release, a manned asset would typically seek to remask the aircraft to avoid reciprocal fire from enemy entities. With an unmanned vehicle executing this mission, though, the rotorcraft can shoulder the additional danger from remaining visible after a popup fire. With this in mind, the UAR should immediately execute a position shift either laterally (optimal) or vertically while maintaining a scan over the battlefield to search for other enemies. If no additional targets are sighted, the tactic ends and is transitioned out of. If targets are sighted, the statechart is transitioned back to the weapons release stage and the cycle is repeated.

Scenarios

The scenarios used in OneSAF focus on the autonomous use of this tactic to test out the continual unmasking of the autonomous rotorcraft while multiple targets are engaged. In the baseline scenario the vehicle uses the standard actions as programmed into OneSAF to vertically unmask, fire, and then remask the aircraft. In the tactical scenario, the vehicle is programmed to maintain a continual visible presence to the engagement area in order to discover additional enemies. Across both scenarios, the UAR vehicle is used to isolate the performance of the attack tactic relative to a single airframe.

The enemy chosen for this scenario is again the SA-8 mobile missile launcher. For this tactic, though, two SA-8s are settled in the engagement area. The additional enemy allows us to see whether both targets are engaged on the initial popup with the tactic. However, with the additional enemies and the added advantage to the red forces, we expect the UAR's survivability across both scenarios to be less than the SA-8s. Furthermore, we expect the survivability of the autonomous rotorcraft to be significantly less in the tactical scenario as it does not seek to conceal itself after the first Hellfire launch. The tactical scenario can be seen in the following screenshot; the bottom of the figure shows the UAR reaching its popup altitude of 21 meters AGL. The two SA-8s are again targeted in the white box surrounding them, thus indicating their presence is visible to the UAR at 21 meters of altitude.

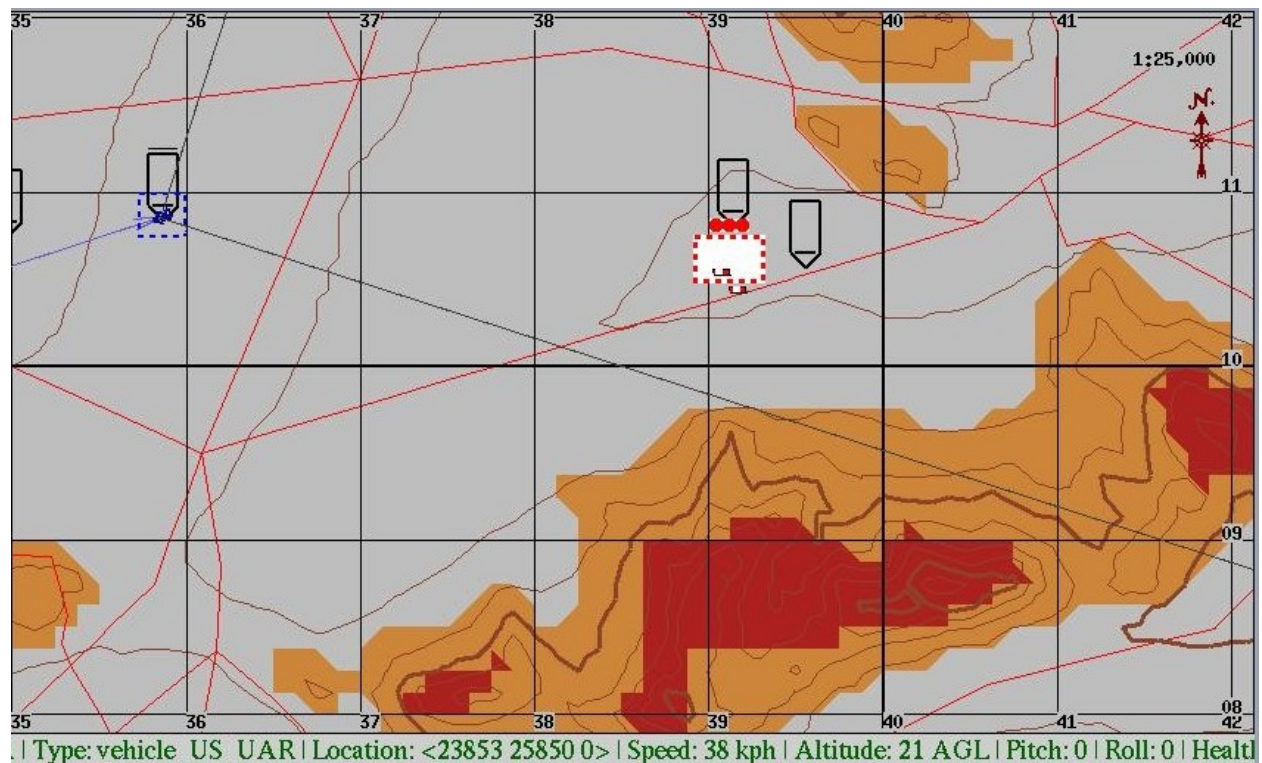

Figure 4.8: Popup Fire Tactic Screenshot

Results & Analysis

The baseline scenario produced slightly unexpected results; with regards to the relative survivability of the UAR compared to the SA-8 platoon, the UAR performed much better. That the autonomous rotorcraft survived more than the SA-8s is a testament to the performance of the manned tactic; by concealing itself until the opportune time for firing, the UAR is only visible for a few seconds for the SA-8s to acquire radar lock. As seen in the results, the survivability of the UAR vehicle performing the manned tactic (a single-popup multiple times) was greater (86% to 30% average survivability).

Popup/Hovering Fire

Type Baseline
 Scenario Name PopupBaselineThree.1.gz
 Run Date 3/19/2005
 Scenario Runs 50

Vehicles:

Blue	Red
1001 UAR	1003 SA-8 1004 SA-8

Vehicle ID	Data			Survivability
	Type	Team	# Losses	
1001	UAR	B	7	86.0
1003	SA-8	R	35	30.0
1004	SA-8	R	35	30.0

Table 5: Popup Baseline Results

In the tactical scenario, the results showed an improvement in the survivability of both forces. If considering the UAR a non-expendable asset, this is positive in that the autonomous rotorcraft was still able to accomplish the mission 50% of the time yet surviving in all scenarios except one. However, if approaching the scenarios primarily with the objective of decreasing the enemy’s survivability, these results are not beneficial. That the survivability *increased* when it would be expected to decrease for all entities is result of a reaction to contact function programmed within the helicopter. At the instance of first sighting the enemy, the randomness generated within the scenario runs would frequently control the helicopter to immediately descend out of LOS; hence the increase in survivability for the UAR. However, when the vehicle immediately descended, it also prevented LOS with the enemy and therefore engagements with the SA-8s (explaining the SA-8s increase in survivability).

Popup/Hovering Fire

Type Tactic
 Scenario Name PopupTacticFour.1.gz
 Run Date 3/19/2005
 Scenario Runs 50

Vehicles:

Blue	Red
1008 UAR	1006 SA-8 1007 SA-8

Vehicle ID	Data			Survivability
	Type	Team	# Losses	
1008	UAR	B	1	98.0
1006	SA-8	R	25	50.0
1007	SA-8	R	25	50.0

Table 6: Popup Tactical Results

Analysis

In evaluating the methodology's effectiveness in proposing this tactic, each of the areas differed in contributions they made. The field manuals contained much about the hover fire tactic, especially FM 1-140, the Helicopter Gunnery manual. Out of this particular manual came more explicit instructions on how to execute the tactic with attention paid to sighting the wind correction on the aerial rockets. This wind correction, however, caused confusion as it was estimated wind would have minimal impact on the trajectory of a rocket. Interviewing subject matter experts, however, quickly remedied this confusion as again this element of the methodology proved advantageous in the tactic formulation. As explained by Captain Myers, it is not so much the wind that distorts the trajectory of the rockets, but rather the rotor wash that makes hovering fire less accurate for non-precision weapons. Captain Myers also provided great background context for the employment of attack helicopters from the hover position; his explanation of the principles of in ground effect and out of ground effect hover made clear the limitations density altitude placed on the quantity of weapons a helicopter could carry.

In formulating the statechart, the AH-64D Aircrew Training Manual (ATM) cleared up a misconception held by the author. Every citation of a hover fire found prior to the ATM discussed hovering fire in the context of a vertical increase in altitude to unmask the rotorcraft's position. The original statechart's development included this, yet was revised after seeing the ATM documentation and cross-referencing the concept with Major Odom.

The simulation, however, did not contribute much to the methodology by producing results counter to what was expected and not entirely indicative of the tactic's usefulness. Despite multiple simulations and the randomness programmed within OneSAF, the UAR's failure to be better targeted by two SA-8s could speciously indicate this tactic fail proof. However, the lack of more UAR losses may be resultant of other factors, possibly with the enemy chosen. As seen in our results, both scenarios showed better survivability for the UARs over the SA-8s. This situation, though, may not be the case if tested against other enemies.

4.3 Manned/Unmanned Lazing

The Manned/Unmanned Lazing capability presents the third autonomous tactic to be primarily used in an offensive manner yet presents a variation on the employment of the tactic. While the previous two tactics would be executed solely by an autonomous vehicle, the lazing tactic outlines the considerations and behaviors for an unmanned rotorcraft operating in tandem with a manned asset.

Background and Purpose

The emphasis of the UCAR concept discussed in Section 2.2.1 was the use of autonomous vehicles operating in tandem with manned vehicles. In discussing with pilots possible beneficial uses of a UAV, the tactical ability of having it “laze” targets for them was mentioned on several occasions. To understand though, how this tactic may be advantageous, it first is useful to discuss how Hellfire missiles are delivered on target.

At the time of this writing, there are two general variants of the AGM 114 Hellfire missile. The first variant is the Hellfire that acquires its target through use of a laser (the SAL Hellfire for Semi-Active Laser) and the second finds its target through radar guidance (RF Hellfire for Radio Frequency). (In actuality, there are several different makes and models of the Hellfire, but for the purpose of this discussion, we assume these two types, as the majority of the different models are based off these two variants).

The RF Hellfire is the newer weapon of the two having just recently been developed; it can only be fired from the AH-64D Longbow and not the earlier AH-64A model. In a basic summation of how the RF Hellfire works, after the missile is launched and comes off the rail, radar within the Hellfire acquires the target and makes the necessary corrections to steer the missile in towards the enemy target [1].

The other Hellfire variant, however, requires active laser designation in order to lock on to a target. Friendly forces must shine a specifically coded laser on a target that a sensor in the Hellfire picks up; the missile then uses the laser to guide itself towards the target. The “laze” needed to guide the Hellfire can come from any number of sources and most commonly comes from either the helicopter that fired the missile or another helicopter. The most frequent helicopter in the past to laze for an Apache has been the OH-58 Kiowa warrior, an observation and reconnaissance platform. However ground troops can also laze targets for Hellfires.

One consideration taken into account before developing this tactic is whether the “fire and forget” capability of the RF Hellfire could possibly render this mission obsolete for a team of vehicles. Primarily, why use two vehicles to accomplish the mission of putting a Hellfire on target when the RF Hellfire only requires one? This assumption, though, neglects two key considerations. The first is the recent success of using the SAL missiles in Iraq. According to Captain Myers based on his experiences in Iraq, he estimated the RF Hellfire only achieved an approximate 30% success rate in accurately destroying a target “whereas lazed ones hit about every time” [36]. Furthermore, having targeting redundancy with both laser guided and radar guided munitions for the Apache prevents enemy radar jamming efforts from rendering the missile ineffective if only the RF version were to be used.

The tactic then proposed for an autonomous vehicle would be to take over the role primarily held by the OH-58 and serve as the laser designator for Apache Hellfire launches. As LOS must be maintained between the Kiowa shining the laser and the enemy target, the use of an autonomous vehicle frees the Kiowa pilot from performing this dangerous, close-in mission. The statechart and development of this tactic also advances the tactic by having the vehicle perform an extended popup to laze the enemy target. This tactic development is explained more in the statechart description.

Lazing Considerations

In formulating this tactic, two specific aspects of having a laser designator are advantageous for an unmanned system. As explained in detail in the Helicopter Gunnery Field Manual, 1-140, the constraints on a laser designator make it so that in order for targeting to be accurate, the angle between the launcher and the designator must be less than 60 degrees as seen in Figure 4.9. This constraint is necessary in order to insure that the missile “sees” the laser coming from the designator.

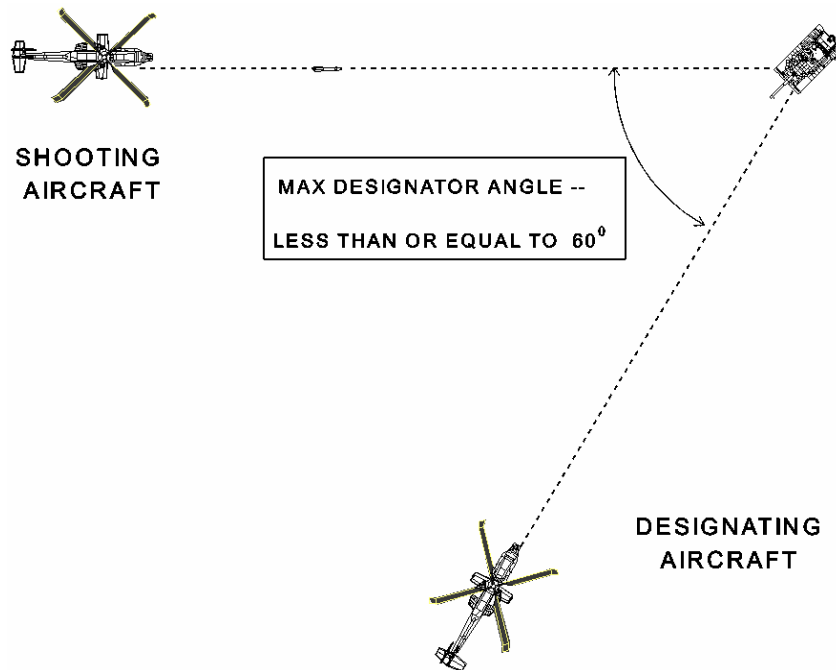

Figure 4.9: Maximum Designator Angle ^[21]

In addition, for safety of the laser designator there must be a 20% span away from the shooting aircraft in order to prevent the Hellfire from acquiring the wrong target and possibly homing in on the laser designator. This restriction is seen in Figure 4.10.

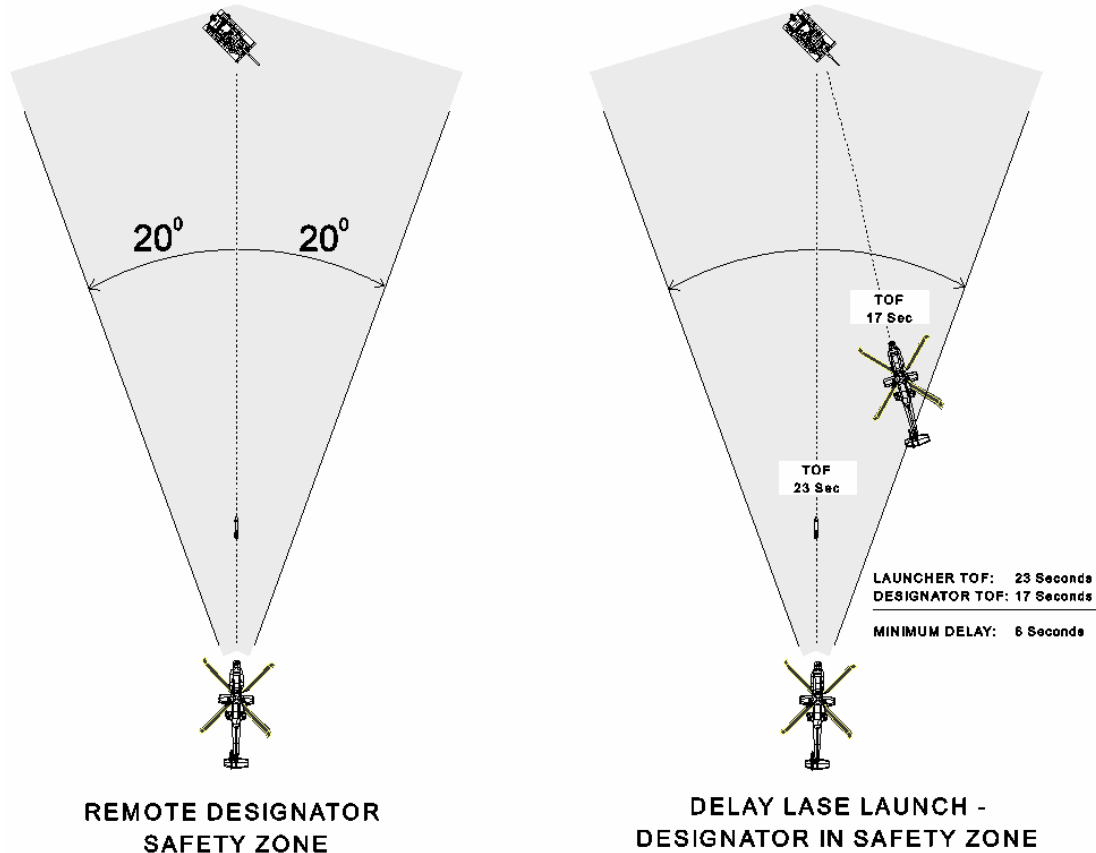

Figure 4.10: Laser Designator Safety Zone ^[21]

The combination of these two restrictions presents an important fratricide avoiding measure to be included in the autonomous tactic. Through the use of sensor and radar technologies, the UAR vehicle can perform the necessary calculations to remain outside of the 20 degree azimuth of the attack helicopter while staying within the optimal 60 degree range for effective laser designation.

The requirement of terminal guidance for a Hellfire is also an important consideration for the missile to accurately hit its target. As explained by Captain Myers, the laze must stay focused on the enemy object with no breaks in targeting for the final six seconds of the missiles flight [35]. If designating on a moving target, it is possible the enemy vehicle’s movement could break LOS if a tank were to “hide” behind a hill. In this situation, the laser designator would have to move away from its position of concealment thus exposing to other enemy fire in the area.

This dangerous mission of following a high value target is nearly perfect for an unmanned vehicle. By using the UAR to consistently reposition itself to maintain LOS regardless of enemy threats, high value targets that might otherwise cause the loss of a Kiowa can still be engaged. This “ideal situation” according to Captain Myers would be enhanced by the sensor feeds coming into the Apache cockpit. The pictures coming into the Apache cockpit, a feature originally prescribed for use in the UCAR program, would enable a last minute divert or cancellation of the missile if the moving target moves into an area that raises the risk of collateral damage.

Finally, an extension of this tactic would be for the Apache to laze targets for the autonomous vehicle. Major Odom described a particular situation where this might be especially advantageous [38]. Due to the features of an automatic laze, the laser will always focus on the heat source with the greatest contrast to the surrounding environment. Therefore, if tracking a target that passes behind a burning tank, the contrast between the hotter, burning tank and a cooler one will pull the Apache's automatic laze finder towards the burning tank. This forces the Apache pilot to pull the laze away from the burning tank and reacquire the moving target. Therefore, an Apache, being better able to laze targets in this scenario might be better suited to "mop up" a battlefield if burning entities litter the landscape. A situation utilizing this scenario could have the Apaches launch their Hellfire missiles from a distance with UAR lazed targets, then the Apache could laze targets for the autonomous rotorcraft using the popup tactic. Major Odom believed that most Apache pilots would understandably prefer the safer mission of firing while masked by terrain. He based his claim on the fact that no one really enjoys being shot at [38].

Statechart

With these considerations in mind, we present the following statechart outlining the events and transitions particular to an autonomous rotorcraft performing this tactic. While the premise of the tactic still remains to replace the manned performance of this mission, there may be deviations from how the manned assets currently execute the tactic.

Unmanned
Laser
Designator

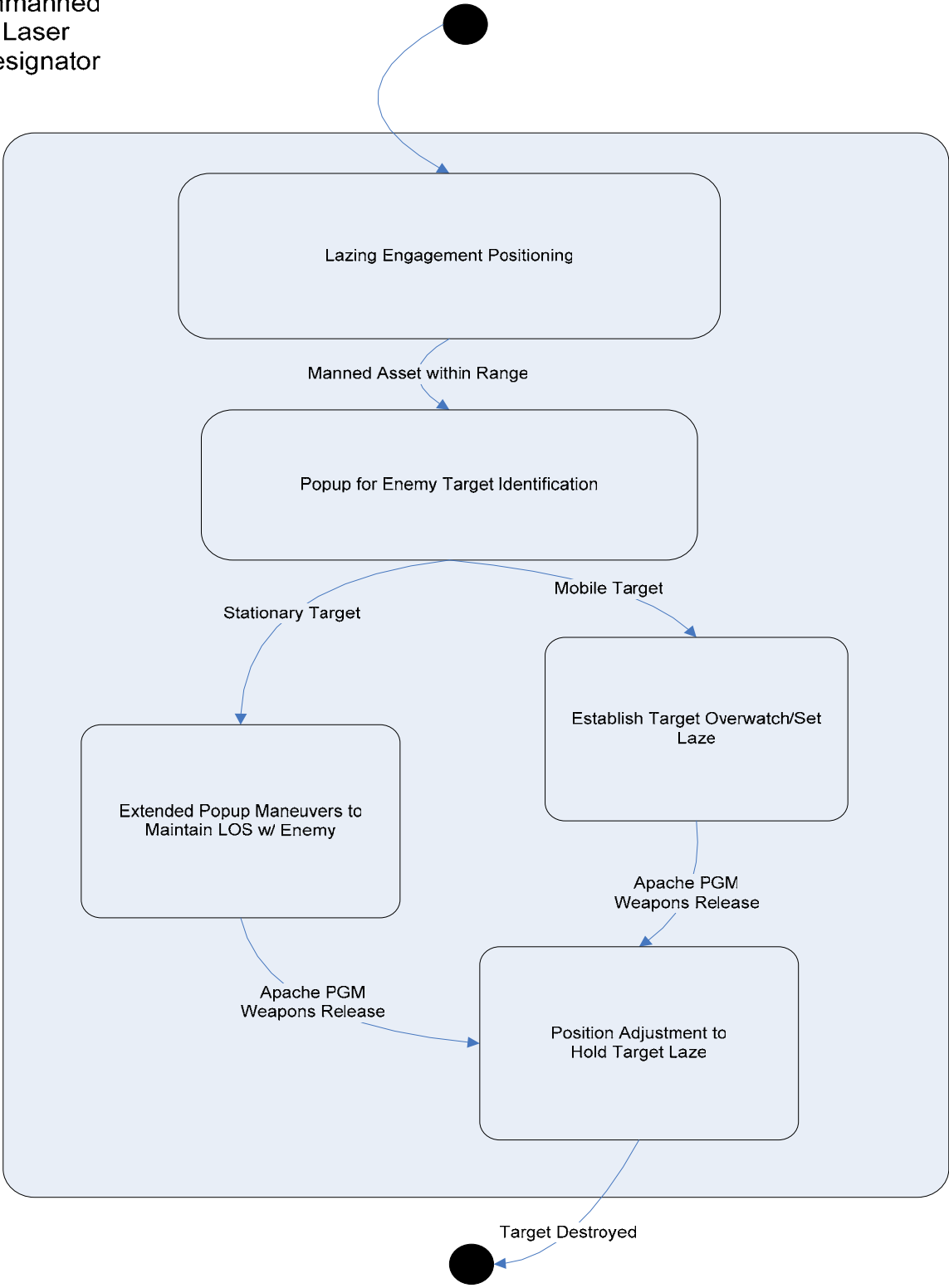

Figure 4.11: Unmanned Laser Designator Statechart

Upon initiation of the lazing tactic, the initial step is the most important and influential to the success of the mission. In establishing the optimal position with which to laze the targets, the unmanned vehicle must consider the positioning of both the enemy target and the manned firing vehicle as described before. Using sensors, the UAR must establish a position that is both within the 60 degree window from the launcher to the unmanned asset yet outside the 20 degree side barrier found to both sides of the enemy; it would be optimal for the vehicle to establish this initial position while concealed to increase survivability. In addition, the rotorcraft must find this position well ahead of the manned asset by reconnoitering the area with the knowledge of the approximate position with which the Apache intends to launch its Hellfire from.

After establishing the position with which it intends to laze from, the unmanned vehicle should remain concealed behind its position. While masked, the autonomous vehicles must wait until its manned teaming asset is within range of its weapons distance; current data for the SAL Hellfire places this distance at about eight kilometers [1]. The eight kilometers, though, cannot be hard coded as the distance with which the range requirement is met; certain scenarios, such as those in mountainous terrain, could dictate closer launchers.

Once receiving confirmation the manned asset is within range, the tactic transitions to the next state, and the unmanned vehicle pops up to acquire the target and send a sight picture back to the Apache of the target area. In doing this, the UAR allows the Apache to confirm that this target is still correct and that collateral damage situations have not occurred preventing launch. In this initial pop-up, however, the vehicle will also determine whether the vehicle is moving or stationary, significantly affecting the ability to maintain a laze on a target.

If the vehicle is stationary, then the tactic becomes much simpler. After establishing the altitude with which it needs to maintain LOS, the autonomous vehicle simply holds this altitude and position to enable the laze to impact the target. After the Apache has confirmation that the target is highlighted, the pilot can release the SAL Hellfire from a masked position and allow the unmanned vehicle to do the dangerous work of holding the laze. The UAR vehicle will then shift its position after the first missile is impacted in order to laze for additional targets. Although this makes the vehicle more vulnerable, it presents an aggressive advantage of the unmanned vehicle by allowing the Apache to engage more targets.

However, if the target is moving, the autonomous rotorcraft will likely have to move from its pop-up laze position, as the enemy tank or truck attempts to mask its position. To mitigate the possibility of losing LOS and therefore missing the target, the UAR should immediately track to an overwatch position above the enemy to allow the terminal guidance necessary for impact. Once the target is destroyed, the tactic is ended as seen by the transition out of the statechart. At this point, the team could either return to base or engage another set of enemies with the lazing tactic.

Scenarios

In running simulations to test our autonomous tactic, the baseline scenario used the current manned pairing of an AH-64 and an OH-58 to attack two enemy SA-8s. The OH-58 served as the laser designator in this mission and lazed the SA-8s from within the 60 degree angle necessary for an effective designation on the target. As there were two SA-8s, the OH-58 popped up once for each target in order to allow the Apache to fire a SAL Hellfire. Then, for the tactical scenario we changed the units by using a two-ship of helicopters representing an AH-64D helicopter in control of a UAR vehicle. This tactic represents an interim use of an autonomous vehicle by having the UAR execute the more dangerous mission of lazing the target

and holding its position to allow for additional targeting all during the first pop-up. By this design, the Apache is allowed to remain concealed by firing from a distance well-outside the enemy's LOS and range. The entities tested against were again two SA-8 surface-to-air missile launchers for their ability to engage short to medium range air assets.

As seen in the following screenshot of the tactical engagement, the UAR vehicle is positioned atop the mountain range in the upper left portion of the screen while the Apache is below it. The AH-64D remains behind the smaller hill except when needing to fire; at this time, it will then rise atop the hill as seen in Figure 4.12. The two enemy SA-8s are positioned to the right of the screen, oriented in the direction of the UAR/AH-64 team.

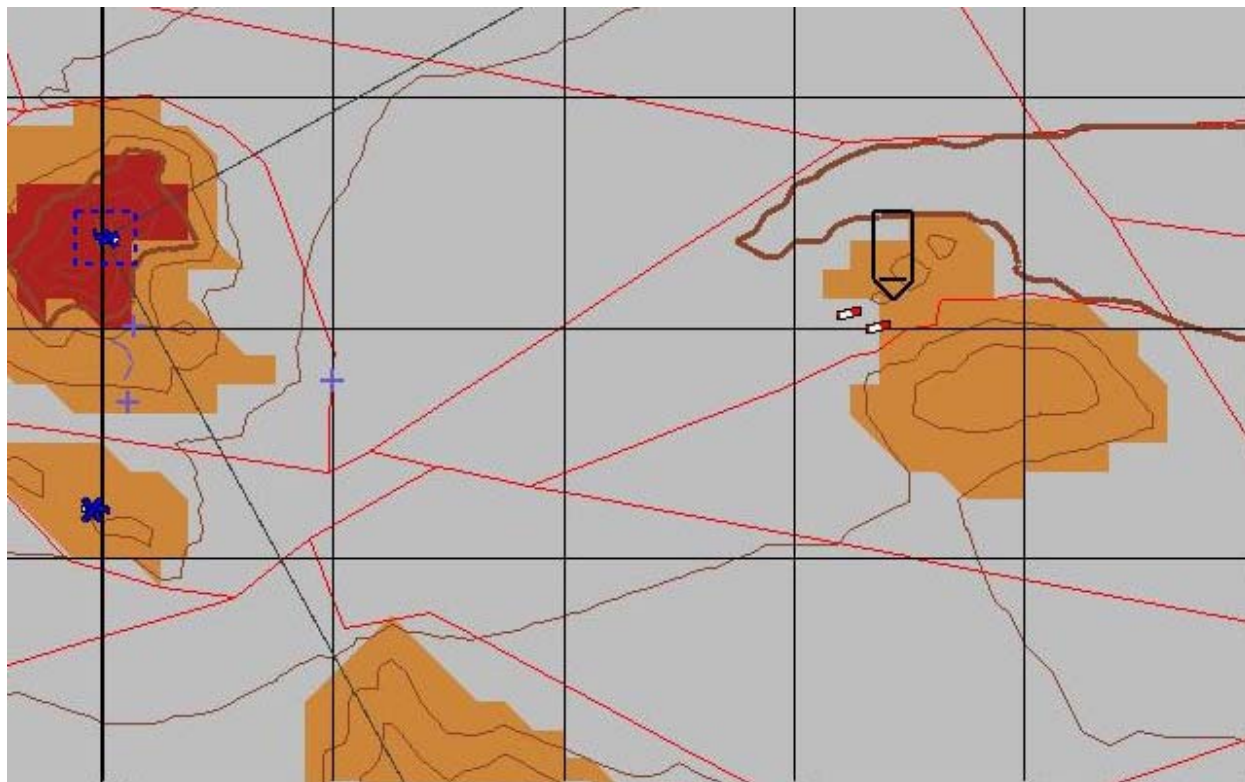

Figure 4.12: Laser Designator Screenshot

In determining expected results for the scenarios, two potential results could occur. The first is that the survivability of the UAR in the tactical scenario should go down when compared to the OH-58 used in the baseline scenario. As the UAR is programmed to stay popped up longer to laze both targets, it should be hit by enemy fire either equal to or less than the number of hits the OH-58 took. In addition, we expect the number of hits taken against the AH-64 to remain low in both scenarios as it should be able to release its munitions while concealed.

Results & Analysis

The results of the simulation runs indicate the tactic is one possible use in a teamed pairing of a Longbow Apache and an autonomous vehicle. In the baseline scenario, the friendly forces lost the majority of engagements as their average vehicle survivability lagged behind the enemy forces by a margin of 65% to 95%. The OH-58D suffered the most losses of any entity in

the simulation, which was to be expected as it was lasing targets for the Apache. In addition, the Apache did suffer some losses as its survivability in the scenario was only at 72%. In determining the cause of this, the Apache was visible through line of sight during its attack which likely was the result of it having to popup more before firing its missile. If firing too close and at too low an altitude behind the hill, the Hellfire would come off the missile rack and not have the minimum distance to climb over the hill.

Type Baseline
Scenario Name LaserBaselineEight.6.gz
Run Date 4/5/2005
Scenario Runs 50

Blue	Red
1009 AH-64D 1010 OH-58D	1008 SA-8 1007 SA-8

Vehicle ID	Data			Survivability
	Type	Team	# Losses	
1009	AH-64D	B	14	72.0
1010	OH-58D	B	21	58.0
Blue Average				65.0
1008	SA-8	R	3	94.0
1007	SA-8	R	2	96.0
Red Average				95.0

Table 7: Laser Designator Baseline Results

The results of the tactic scenario show potential for tactical use of a lasing tactic in an autonomous rotorcraft. The average survivability for the blue vehicles stayed relatively the same which showed the tactic was not excessively advantageous to the blue vehicles; the AH-64D was again targeted on about a third of the engagements resultant of it being visible in order to release its Hellfire missiles. The tactic when employed, though, did bring down the SA-8s average survivability by roughly a third. The tactic, while exposing the UAR for a longer period of time, did also enable the Apache to attack more of the targets which lead to the SA-8s being targeted in more of the scenarios.

Laser Designator

Type Tactic
Scenario Name LazeTacticTen.1.gz
Run Date 4/5/2005
Scenario Runs 50

Vehicles:

Blue		Red	
1010 UAR		1009 SA-8	
1011 AH-64D		1008 SA-8	

Vehicle ID	Data			Survivability
	Type	Team	# Losses	
1010	UAR	B	21	58.0
1011	AH-64D	B	15	70.0
Blue Average				64.0
1009	SA-8	R	16	68.0
1008	SA-8	R	17	66.0
Red Average				67.0

Table 8: Manned/Unmanned Lazing Tactic Results

Analysis

In analyzing the development of this particular tactic in the three-pronged methodology, the most beneficial aspect was the comments and feedback given by subject matter experts. As cited earlier, in posing the question to the various pilots about beneficial uses of an autonomous helicopter to help them do their job, several of them cited the lazing aspect currently done either by the Kiowa, the Apache itself or forward deployed ground forces. While the tactic had not seriously been considered prior to the interviews, the importance the pilots placed on it was motivation enough to learn more through field manuals. Also in the pilot interviews, more key considerations deeming it beneficial to have the UAR vehicle perform the mission came to light. Major Odom in particular cited a capability in the Russian built T-80 tank that could divert a laser away from itself and back towards the entity marking the tank [38]. Furthermore, Captain Myers explained the beam divergence factor that occurs when Apaches self laze targets from a distance. At long distances, the accurate point of the laser spreads, thus making pinpoint precision while lazing difficult. Captain Myers stated that with an unmanned laser designating the target from a closer distance, the laser's divergence could be overcome which thus enables more precise engagements. Other aspects of the methodology were beneficial, such as the field manuals discussing the minimal angles necessary in order to show the laze, however, for this tactic, subject matter experts were able to provide specific guidance in the importance for this tactic to be researched and presented.

4.4 Forward Tether

In addition to the three attack methods presented in this thesis, we also outline three other tactics which are not primarily offensive in nature. The first of these presented is the forward tether.

Background and Purpose

Helicopters in transit over any hostile terrain are in an extremely precarious situation; this vulnerability is only multiplied when unexpected enemies appear on the helicopter's radar. Often referred to as a pop-up threat, these enemies are of more concern to slower, lower flying rotorcraft than faster, higher fixed wing airframes. However, not all helicopters are entirely defenseless. When targeted by a pop-up threat, attack rotorcraft such as the Apache and the AH-1 Cobra have the benefit of being able to fire in the general direction of the threat before turning to mask or seek concealment. Larger transport helicopters, such as the Chinook, however, lack the ability to lay suppressive fire in the general vicinity of a perceived threat. By being unable to cause an enemy to "duck their head," larger helicopters are therefore easier targets for enemy fire while also permitting multiple shots from an enemy without fear of retaliation.

In this inherent vulnerability for the Chinook, there lies an excellent capability for an autonomous rotorcraft. A forward tethered UAR, or a single vehicle flying in advance of the manned platform, would provide advance reconnaissance while flying over hostile terrain. By providing advance warning capabilities, if surface-to-air missile launchers are found in the designated flight path, enough timely information could be provided to allow pilots to choose a new flight path. In addition, purely attack airframes such as the AH-1 Cobra and AH-64 could also benefit from this tethered protector when performing armed reconnaissance missions. According to Captain Myers, this pairing of manned and unmanned assets would be especially advantageous in deep strike missions by "letting the UAV fly down range to develop the mission." Furthermore, if used in engagements not far from indirect fire support, he noted an autonomous rotorcraft could execute the mission at a greater distance from the manned controller. Within close ranges and with covering fire protection from artillery, a forward tethered UAV could circumvent manned constraints such as crew rest and greater fuel requirements.

A recent engagement at the beginning of Operation Iraqi Freedom highlighted the added benefit an autonomous helicopter system could bring in an advance warning/forward tethered position. In an interview with Captain Tyler Smith, a Blackhawk pilot for the Army who served a year in Iraq, a battle was told where in March of 2003 a company of Apaches was badly shot up over the city of Karbala en route to their deep attack objective. Although not facing a significant adversary with traditional weapons capabilities, the Apaches were nevertheless overwhelmed by the small arms fire of the Iraqi forces; the losses for the mission included one downed Apache and approximately 33 other Apaches significantly damaged from ground based rifle fire [24]. In this instance, the Apaches were only able to gauge the severity of the small arms fire after having over flown the cities on their route. An autonomous unmanned vehicle would at the least have drawn the initial brunt of the fire and thus possibly provided an advance warning to the magnitude of the enemy forces. The commander with this additional information could have re-planned his route around the city or backed away from the mission entirely.

Statechart

Based on the potential benefits this tactic could bring, we constructed the statechart in Figure 4.13 to outline key states and transitions involved in this tactic.

As seen in the below statechart, the initial event upon activation of the forward tether tactic is placing the automated rotorcraft in an advantageous position to conduct forward reconnaissance. In determining the optimal distance in front of the manned asset for a UAR, various factors must be considered.

If placing the UAR vehicle excessively far away from the vehicle, the principle concerns are the ability to support the autonomous rotorcraft in an unexpected engagement and the ability to continually see it. If a UAR is placed too far to the front, there lies the risk of the unmanned asset being excessively exposed to an enemy attack before a manned asset can join the fight. This situation, however, is unlikely considering ongoing development and emphasis of threat avoidance trajectory generation algorithms that will allow vehicles to navigate away from threats in minimal time. [43] In addition, weather constraints must be taken into account as visibility could play a factor in setting the distance between the two entities. While some helicopter pilots may be comfortable losing visual acknowledgement of their unmanned responsibility, others may prefer to maintain constant visual contact of their vehicle, thus preferring them closer.

There are two key considerations when evaluating if the unmanned asset is too close to the manned platform controlling it. The first is the total amount of ground that must be covered in order to effectively sweep an area for possible enemies. If a UAR vehicle is too close, than little additional territory is covered than what the manned asset can already visually detect. Furthermore, vehicles remarkably close to each other pose a significant danger to the manned asset. While not common, incidental collisions between friendly helicopters have been documented both in training missions and in combat.

Forward Tether

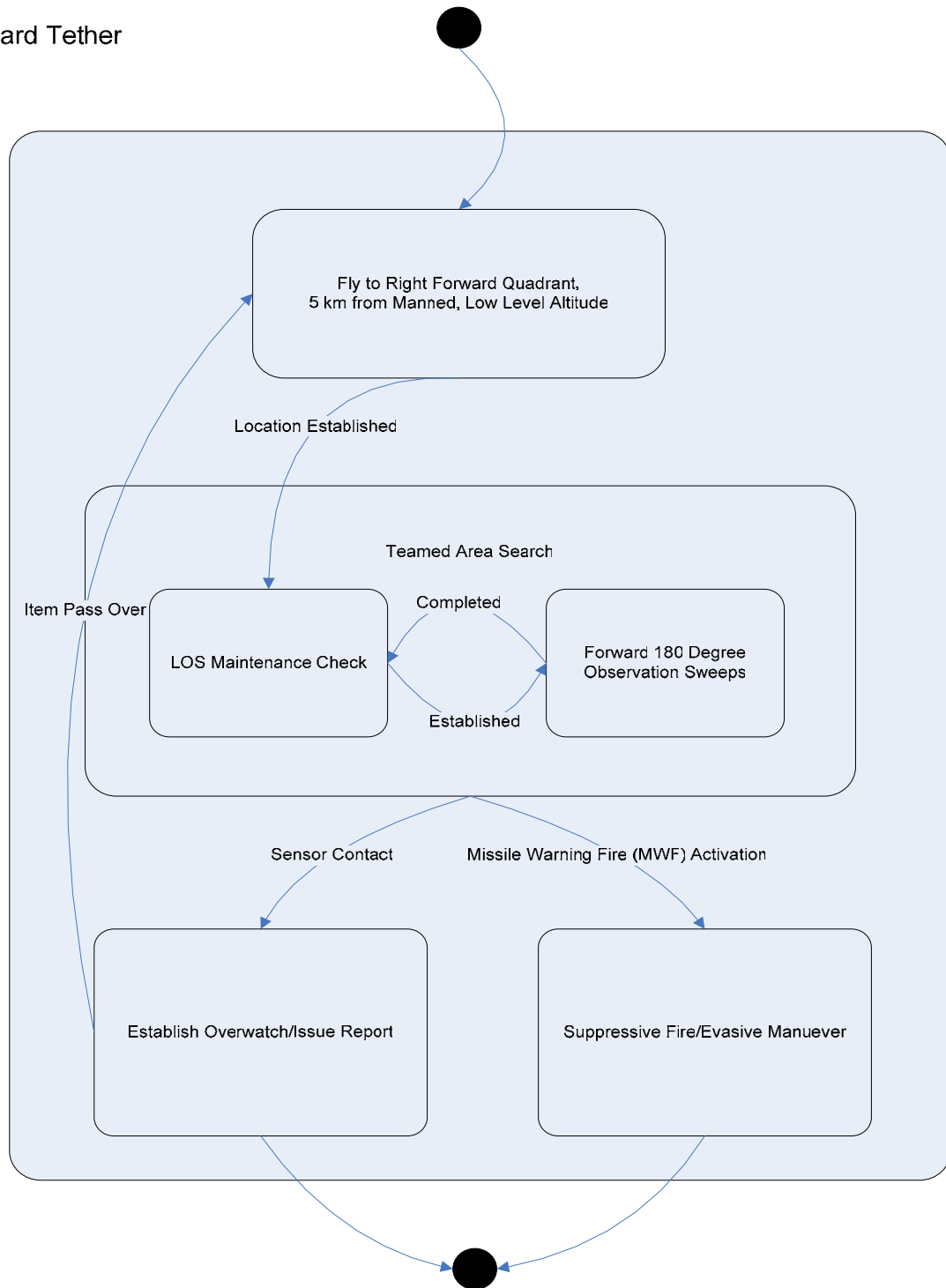

Figure 4.13: Forward Tether Statechart

Therefore, as the tactic calls for the automatic tether of the UAR vehicle to the Apache so as to mirror the movements of the manned asset, we have selected an arbitrary value to portray the previously mentioned considerations. While the vehicle could be placed at any number of approximate distances, initial placement of the vehicle is in the forward right quadrant distance

approximately five kilometers away. The specific distance of five was chosen for two key reasons. At that distance, if the UAR sensor detects an object, the Apache can close from its position 5 kilometers away to the UAR's position in roughly two minutes, considering the time needed to build to the Apache's maximum level cruising speed (143 knots) [42]. In addition, at a distance of five kilometers, the Apache is able to stay outside of the maximum *effective* range of highly proliferated small arms to include the RPG-7 (500 meters for stationary targets), the AK-47 (500 meters), and the SA-18 (~5000 meters) [46][50][57].

In choosing an effective altitude, it is assumed better sensor coverage is available at higher altitudes. However, as higher altitudes greatly increase the threat to a helicopter, the issue of altitude then becomes a matter of judging the expendability of the UAR. In terms of Army usage, the major altitude flight profiles of a helicopter are Nap of the Earth, Contour and Low Level in ascending levels of relative position above the ground.

Low level – Constant altitude and constant airspeed. Used for rapid relocation in rear areas.

Contour – Varying altitude and varying airspeed. Follows the contours of the earth. Used for transition from rear areas to the vicinity of the forward areas.

Nap of the Earth (NOE) – Varying altitude and varying airspeed. Flight as close to the earth's surface as terrain, vegetation, obstacles and ambient light will allow. Used in forward areas.

Figure 4.14: Flight Altitude Definitions ^[20]

The unmanned rotorcraft's placement at a low level altitude can vary based on the terrain and expected enemy contact; however, the use of the UAR at a higher altitude than the manned platform is essential for the tactic to be effective. At an altitude of approximately 1000 feet off the ground, the UAR vehicle can sense more than its manned asset and possibly accept the risk of being more susceptible to enemy fire. While the UAR is not an expendable asset, its use in such missions necessitates it to take on higher flight profiles. If a UAR is utilized at a height that does not give it an advantageous viewing periphery, then there is little use in having a UAR perform such a mission.

Once the position has been established, whether it is the recommended 5 km away and 1000 feet of altitude or other parameters based on commander's guidance, the statechart transitions over to an event of maintaining this position while conducting the reconnaissance or search of the area. A key aspect, though, is the ability for the vehicles to maintain LOS. While potentially unnecessary in the future due to satellite communication, the LOS restriction allows the UAR vehicles to receive any radio transmissions. In the majority of rolling or level terrain, the five kilometer distance would generally permit LOS to be maintained. In a mountainous region, however, closer spacing between the vehicles may be needed in order to keep the vehicles in continuous LOS contact.

The second important event perpetually cycled through in conducting the area reconnaissance is the forward 180 degree observation sweeps. By continually scanning the full area in front of the vehicle, the UAR neglects areas already covered while still giving advance notice to a manned platform of what problems may lay forward. It is under this thinking that the sweeps are not conducted behind the UAR vehicle as that presents a terrain section already reconnoitered.

Finally, while conducting the area search looking for enemies, a transition out of the search will likely happen due to one of two instances. The first is that while flying along, the UAR sensors or radars could pick up an object. In this instance, the UAR will issue a report of finding to the Apache (through either a spot report or a wire transmission) to alert it of the finding. The UAR will then proceed initially to an overwatch position above the object to allow monitored surveillance until the Apache can decide whether to pass over the item or take further action. If the manned asset determines to neglect the spotted item based on intuition or a pre-determined bypass criteria, then the team will continue on with the mission and the UAR will establish its position above, in front of and to the right of the manned teammate. The tactic would then repeat until mission completion or enemy sighting.

The second possibility is that the UAR vehicle will be targeted and fired upon by enemy forces. In this instance, the UAR could immediately take one of two actions depending on the terrain and suspected enemy. If in an urban environment, the UAR would immediately initiate evasive maneuvers to leave the troubled area. If in a more remote area, however, the UAR could release some suppressive fires to cause the enemy to seek cover as the threat of collateral damage does not exist. Afterwards, it would then initiate its pre-programmed evasive maneuvers to mask its position. Since the team is being fired upon by the enemy, the forward tether tactic would likely end at that moment, as seen in the transition out of the statechart, and the helicopters would then initiate an attack tactic or continue to distance themselves by flying towards safety.

Scenarios

In modeling the forward tether tactic, the baseline scenario consisted of placing an AH-64D / UAR team together flying in a standard staggered left formation distanced by only two rotor lengths. This teaming was then flown on a reconnaissance mission through a mountain overpass depicted in the upper right of the picture below. In congruence with a typical mission in which enemy contact is possible but not likely, the teamed pair flew the same altitude at approximately 30 feet AGL for the entire mission. However, on the other side of the mountain hidden by LOS was a squad of three enemy troops holding SA-18s.

Consequently, to test the forward tether tactic, and in particular the ability of an advanced warning and detection capability, the tactical scenario consisted of the same AH-64D and UAR team except with the distance and altitude adjusted for both entities. The SA-18 grouping was held in the same place, however, the altitudes on the team was adjusted as the AH-64D then flew at NOE while the UAR vehicle was programmed to raise its elevation in this scenario to 1000 feet above ground level. Furthermore, the vehicles were offset per the methodology described in the statechart and the UAR was placed at a distance of about five kilometers forward and to the right as seen in seen in Figure 4.15, a screen shot of the simulation.

In the baseline scenario, we expect both vehicles will achieve similar survivability ratios as the team together will either be targeted by the three SA-18s or be able to evade the MANPADS radar sweep and possibly fire first at the enemies. However, with the tactical scenario, the results will likely show a decrease in the survivability of the UAR vehicle and an increase in the Apache's ability to remain undamaged. In addition, in the tactical scenario, the UAR will encounter the SA-18s first while the Apache remains outside the effective range of the surface to air missiles. With LOS maintained between the two entities throughout the missions, this should, at a minimum, alert the Apache to the SA-18s presence thus giving the AH-64D in a real battle the time to determine if a withdrawal or further attack is needed. In our simulation,

however, the AH-64D continues on with mission in order to see if the advanced warning increases its survivability.

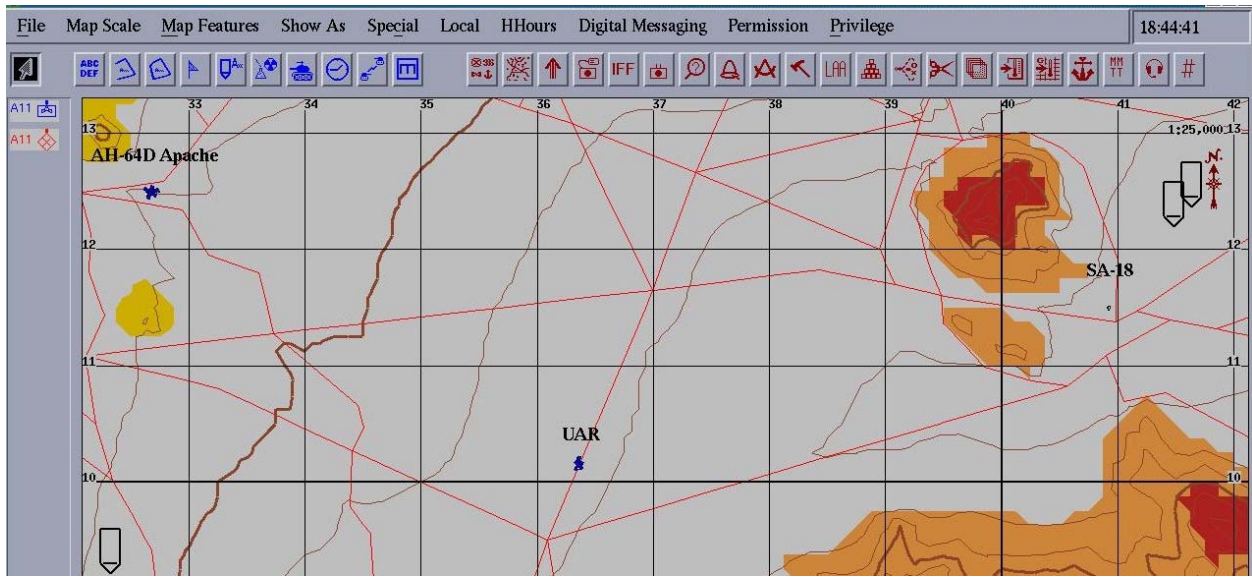

Figure 4.15: Forward Tether Tactic Display

Results & Analysis

Over the aggregate of the fifty simulation runs for the baseline and tactical scenarios, the results are generally in line with what was expected to occur. As depicted in the table below, the survivability of each blue entity was close, yet on average remarkably lower than the performance of the red forces. In fact, on only three occasions were the AH-64D / UAR team able to effectively target one of the SA-18 enemies.

Forward Tether

Type Tactic
Scenario Name FTTacticOne.5.gz
Run Date 3/1/2005
Scenario Runs 50

Vehicles:

Blue	Red
1011 AH-64D 1012 UAR	1010 SA-18 1009 SA-18 1008 SA-18

Vehicle ID	Data			Survivability
	Type	Team	# Losses	
1011	AH-64D	B	0	100.0
1012	UAR	B	50	0.0
Blue Average				50.0
1010	SA-18	R	0	100.0
1009	SA-18	R	0	100.0
1008	SA-18	R	5	90.0
Red Average				96.7

Table 9: Forward Tether Baseline Results

When the scenarios were changed to test the principles of the forward tether tactic, the results fell in line with the predicted hypothesis. The survivability of the Apache did increase, although at a greater cost to the UAR vehicle. The UAR was hit in every scenario although its sacrifice prevented the Apache from being effectively targeted once. While many people would certainly be unhappy with the expendability of the autonomous vehicle, any pilot would probably gladly accept the outcome.

Forward Tether

Type Tactic
 Scenario Name FTTacticOne.5.gz
 Run Date 3/1/2005
 Scenario Runs 50

Vehicles:

Blue	Red
1011 AH-64D 1012 UAR	1010 SA-18 1009 SA-18 1008 SA-18

Vehicle ID	Data			Survivability
	Type	Team	# Losses	
1011	AH-64D	B	0	100.0
1012	UAR	B	50	0.0
Blue Average				50.0
1010	SA-18	R	0	100.0
1009	SA-18	R	0	100.0
1008	SA-18	R	5	90.0
Red Average				96.7

Table 10: Forward Tether Tactic Results

Furthermore, and in another positive sign of the feasibility and use of the prescribed tactic, the SA-18s were actually attacked and immobilized in two more scenarios than happened in the baseline tactic. The advance warning of the UAR not only increased the AH-64D survivability considerably, but it also permitted the vehicle to engage the SA-18s more frequently.

Analysis

The forward tether tactic of utilizing a standoff distance to perform reconnaissance does increase the survivability of the manned asset in the scenarios tested. It is important to keep in mind, though, that the results are not a certifiable stamp that using an unmanned rotorcraft with this tactic will be advantageous in all situations. It is possible that the five kilometer distance is not great enough of a warning, in which case both manned and unmanned rotorcrafts are targeted immediately by enemy air defense. Or it is possible the forward location of the unmanned asset does nothing but tip off enemy forces to the Apache's presence. In this situation, the autonomous rotorcraft flies over the top of a concealed air defense system just to give a SA-18 crew the time necessary to target the manned helicopter. While there are hundreds of conditional situations that could make the tactic detrimental, the premise of providing additional surveillance capabilities and advance warning to both attack and utility helicopters is of potential benefit to mission planners. The tactic results from the simulation do represent the extremes of the UAR being immobilized on every instance and the Apache not being hit once. Nevertheless, they point towards future development of this tactic and its suitable inclusion in mission planning.

A potential drawback to this tactic, though, is the possibility of task overload for the manned asset controlling a UAR. As it stands, there are very few crew members aboard any of the Army's current fleet of helicopters that are excessively free of responsibilities. In the Apache, for example, the back seater flies the aircraft while the front seater is responsible for weapons firing and gunnery. When no enemy contact is present, it is possible the gunner could

have the time to check on and be responsible for the unmanned asset. However, at the first instance of enemy fire, both the pilot and the gunner become overloaded with objectives to include flying the aircraft so as avoid fire for the pilot and tracking targets while communicating with other pilots for the gunner. At the moment of enemy contact, the autonomy of the unmanned rotorcraft would have to control the vehicle fully as crew members would likely not be able to.

Finally, the three-pronged methodology in developing this tactic was beneficial. To begin, the very name of the tactic was originally misleading. In discussing the premise of what I was trying to represent to Major Odom, the first name of “defensive tether” suggested the wrong connotation to an Army pilot. He stated that an armed reconnaissance mission or simply the principle of placing a vehicle to the front for early warning was not defensive in nature and therefore misleading. In addition, other SMEs often cited the need for the tactic, thus prompting research into field manuals and the eventual statechart development. Of particular benefit, found in the initial literature review, was a report released by the Air Maneuver Battle Lab in May of 2000 [32]. One of the key findings of the report was that “UAV observation and surveillance capabilities are complementary to, and not a replacement for manned air maneuver reconnaissance capabilities.” This particular information prompted the use of a team of a manned and unmanned vehicle performing forward tethered reconnaissance which influenced the overall design of tactic and the statechart.

4.5 Communications Relay

The fifth tactic we present is the behavior an autonomous vehicle would perform while serving as a relay for communication between friendly entities.

Background and Purpose

Presently, communication between attack helicopters occurs predominantly by Line of Sight (LOS) communications through secure UHF, VHF or FM radio. In order to maintain LOS communication, anytime an Apache battalion (24 helicopters) or company (8 helicopters) is sent on a mission, a TACC, or Tactical Air Control Center, will launch with them. The TACC, most often a UH-60 Blackhawk, serves as an airborne command post that oversees the battle and directs platoons of helicopters towards targets. In addition, its position above a battle serves as an antenna allowing radio transmissions to carry between two helicopters not positioned with their own LOS capabilities.

In speaking with Major Odom, the possibility of a communication loaded autonomous vehicle supporting Apaches with radio relay seemed not only feasible, but highly beneficial [39]. As Major Odom pointed out from his experience in the back of a UH-60 Blackhawk, the visibility is poor for all occupants except the pilot, which often forbids other occupants from effectively observing the battle. In addition, Major Odom pointed out that in any mission it is imperative for higher level commanders to be aware of ongoing events, and he cited problems of crew recovery as an example of this. Should multiple aircraft get shot down and additional rescue assets need launching, those at Headquarters must be aware in order to send reinforcements. As Major Odom said, “if you cannot communicate with your control center, then you have to do something to fix the situation.”

In addition, another pilot interviewed found benefit in a relay capability to counter the persistent problem of maintaining communication. CW4 Terry Gibson stated that in addition to whatever capabilities are put on future unmanned rotorcraft, they “must also have a relay capability” [15]. In his experiences flying the Kiowa, communication between forces was often the biggest hurdle to overcome when planning and executing missions. In addition, the Air Maneuver Battle Lab at Fort Rucker, Alabama identified communication relay as one the three most important tactical employments for Army UAVs in the future [32]. Finally, according to the Attack Helicopter Operations field manual, potential transmission problems in operations are described that an unmanned vehicle could easily aid. As stated in FM 1-112, “because of the ATKHB's mobility and potential for operating throughout an entire AO [Area of Operation], the primary means of communication will be radio. However, some radio communications are limited by range and line-of-sight restrictions. In these situations, commanders may lose contact with their aviation units unless radio relays are used” [19].

However there are examples where use of this tactic could not necessarily replace the requirement of having a manned asset on station. Captain Tyler Smith, a Blackhawk pilot, related specific instances where Blackhawks would follow Apaches directly into battle so as to provide a communications relay between the Apaches and Command Control platforms [53]. He also stated, though, that the Blackhawks would serve dual purposes by serving as search and rescue platforms in case one of the Apaches was shot down. While presently there are no UAVs

specifically designed to perform crew recovery, the loading of a UAR with an extensive communication package was still an opportune use of an unmanned rotorcraft according to Captain Smith. At the least, it could enable search and rescue helicopters to drop down closer to the terrain, thus reducing their chances of being targeted by enemy air defense. Optimally, though, it would place fewer personnel in harms way by allowing monitoring of the engagement to occur from headquarters. It is with these things in mind, that the following statechart is proposed to outline key events in the execution of a communication relay tactic for an autonomous rotorcraft.

In addition to scenarios in which an autonomous vehicle could support communication between command entities, an unmanned rotorcraft could also be used more aggressively to support advancing attack helicopters. Presently in deep operations in which helicopters are sent far behind the enemy lines to strike strategic targets, LOS communication must be maintained to insure communication between entities. However, in these deep operations, this prevents these attack platforms such as the Apache from increasing the separation between them and thus covering more distance. By using an unmanned helicopter flying at higher altitudes behind the front line of Apaches, this enables the advancing manned platforms to increase separation while maintaining communication via relays from a UAR vehicle.

Statechart

The most important consideration in this tactic is the maintenance of line of sight communications between the headquarters and the attacking helicopters. Therefore, everything in this tactic that controls the movement of a UAR vehicle should go to support LOS communication. Although in the future LOS communications could become irrelevant with the incorporation of satellite communications, for the time being the majority of radio transmissions occur through line of sight.

Communication Relay

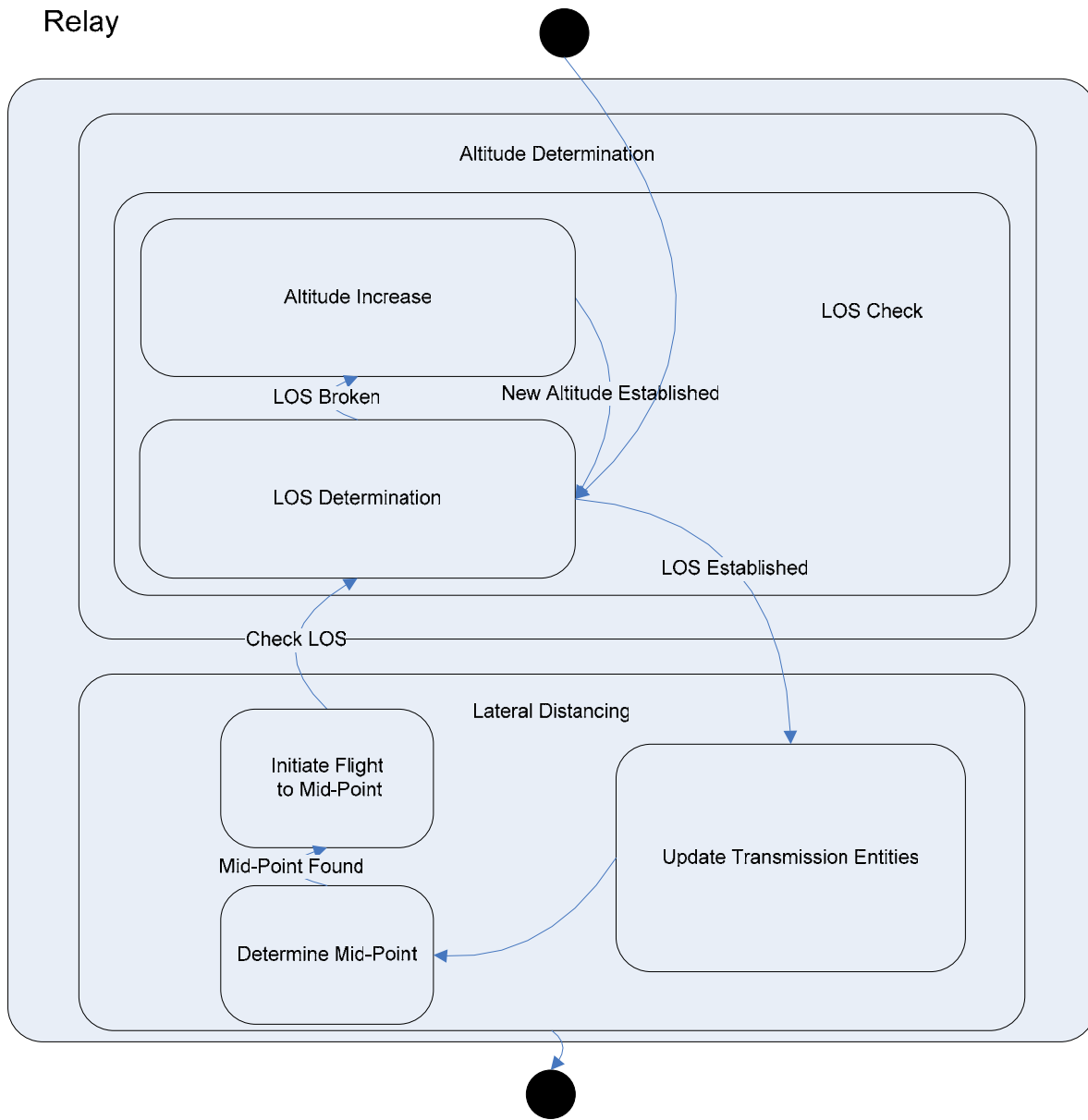

Figure 4.16: Communication Relay Statechart

Upon initiation of a communication relay tactic for an autonomous rotorcraft, the initial event is the altitude determination for the rotorcraft above the ground. As seen in the above statechart, the initial state is to determine if line of sight is established between the pre-programmed entities needed for relay. If LOS has been broken, then the event transitions to a state where altitude is increased, which is the most efficient and effective way to reestablish LOS. While there is the possibility of lateral movements to take into account hindrances from mountains, a vertical increase in position offers the quickest manner to reestablish LOS. Furthermore, lateral movements might not offer the direct sighting necessary as the battle continues and the lead element of Apaches continues along its corridor towards its objective.

If LOS were broken between entities and the vehicle's altitude increased, the next state to return to is a check of whether the altitude increase raise was effective. If it was not, LOS is still considered broken; the above process is repeated. If during this process, LOS is established, the transition is out of the altitude determination event and into the lateral distancing event. If LOS is not established, the increase in altitude and LOS check are continued iteratively until LOS is established.

The purpose of the lateral distancing state is to update continually the position of the vehicle so that it flies exactly equidistant between the headquarters and the advancing vehicles. To this end, the initial state transitioned into is one that updates which entities require the necessary communication relay. As Apache missions are currently flown so that vehicles can maintain LOS en route, then the relay needs only to be with one manned vehicle in the formation. However, as vehicle missions in deeply mountainous terrain might require multiple relay entities, this state could involve establishing a relay between attacking assets and another relay entity. As the communication string is stretched, engagement planners may choose to launch another vehicle to lower the autonomous rotorcrafts altitude to a more realistic level. A second relay could become a requirement if Army planners are given a ceiling on the altitude in which they can fly so as not to disturb other operations by Air Force or Navy fixed wing aircraft.

After the entities to be relayed between have been established, the next step in the process is relatively simple. The mid-point between the advancing vehicles and the headquarters are calculated, and the vehicle alters its position to place itself in that position. In this position updating, the hover abilities of a rotorcraft make it apt to perform this mission at lower altitudes and more specific to company or battalion level engagements. After the position has been updated, the tactic transitions back to an updating of LOS to evaluate whether the change in position disrupted an effective relay. The process of continually updating position and performing LOS checks is then repeated and the circular flow of the tactic is run iteratively throughout the duration of the mission until terminated.

Scenarios

Simulation again relied upon the use of a baseline scenario to represent how manned assets can currently perform the tactic and a tactical scenario that involves employing the rotorcraft as described in the statechart description. The baseline scenario designed for testing the communication relay entailed a battle set up described by Captain Tyler Smith in which a UH-60 Blackhawk follows behind two Longbow Apaches to act as a communication relay. For the baseline engagement, the two Longbow helicopters were placed on opposite sides of a mountain so that LOS would not be established between the entities and thus the Blackhawk would be used as a necessary communication relay. The scenario also used two SA-8s as the enemy force that was "discovered" by the Apaches as they ingressed towards the target area. A screenshot of the engagement can be seen in Figure 4.17.

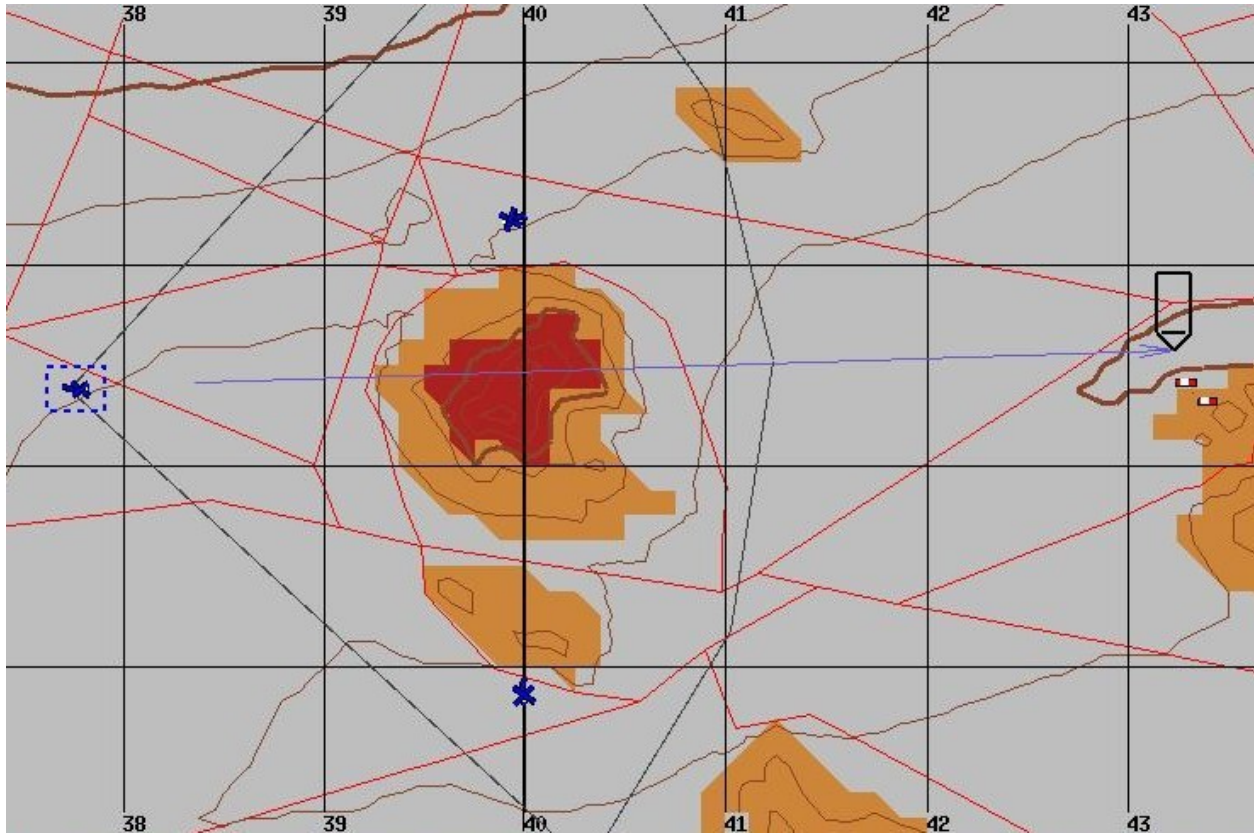

Figure 4.17: Communication Relay Baseline Tactic

For the experimental run, the tactic was run with the UAR placed at a much closer distance to not only insure that LOS communication was maintained between the two entities, but also to bring additional firepower to the engagement. With this additional firepower and a superior numbers advantage in the engagement, we expect that the more aggressive autonomous tactic leads to improved survivability for each of the blue entities. Correspondingly, the red vehicles survivability across the simulation runs should decrease.

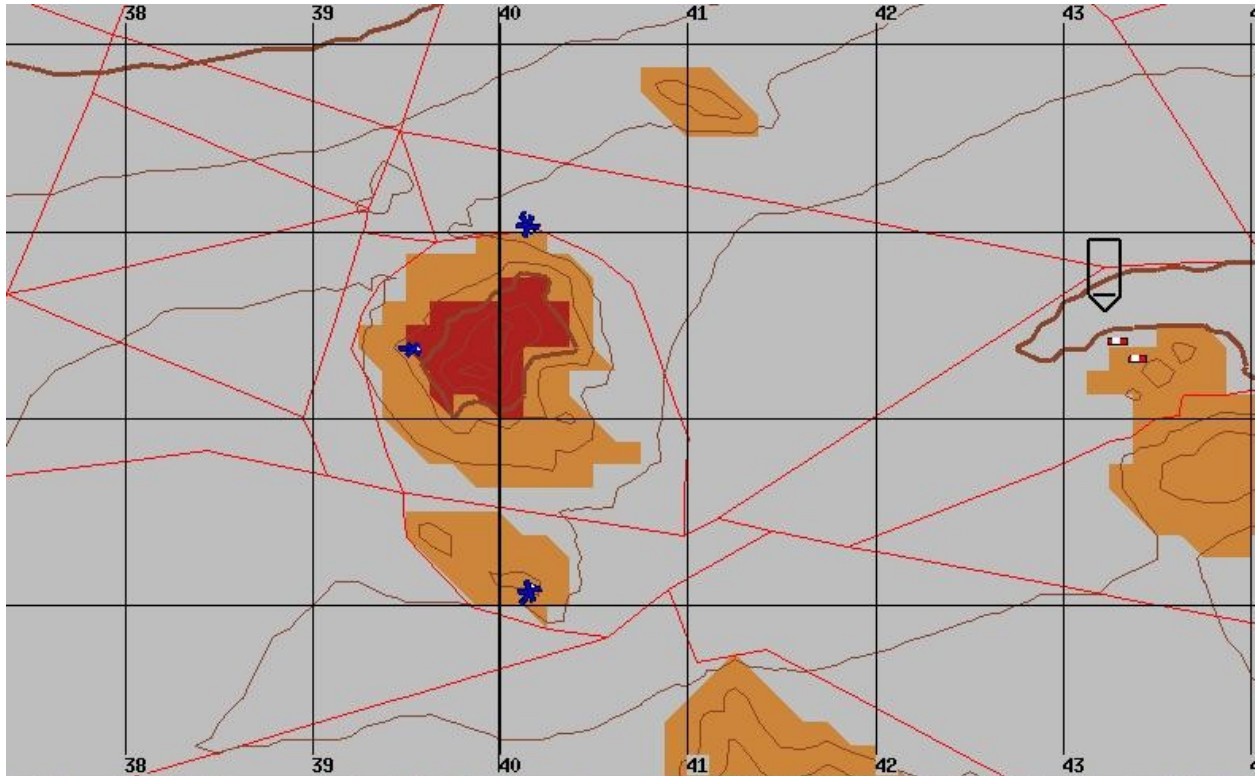

Figure 4.18: Communication Relay Autonomous Tactic

Results & Analysis

The results of the two scenario runs correspond to the expected result of an autonomous rotorcraft possibly improving upon the manned aviation tactic. In the baseline scenario, the AH-64Ds engaged the SA-8s with equal survivability scores; however, the Blackhawk vehicle that remained far behind the engagement had a higher survivability score giving the overall blue team an increased average survivability as seen in the table below.

Communication Relay

Type Baseline
 Scenario Name CommRelayBaseline.3.gz
 Run Date 4/4/2005
 Scenario Runs 50

Vehicles:

Blue	Red
1005 UH-60	1009 SA-8
1011 AH-64D	1010 SA-8
1012 AH-64D	

Vehicle ID	Data			Survivability
	Type	Team	# Losses	
1005	UH-60	B	7	86.0
1011	AH-64D	B	15	70.0
1012	AH-64D	B	14	72.0
Blue Average				76.0
1009	SA-8	R	14	72.0
1010	SA-8	R	15	70.0
Red Average				71.0

Table 11: Communication Relay Baseline Results

For the tactical scenario, the advanced technique worked in increasing the survivability of the manned AH-64D vehicles. Furthermore, the tactic's effectiveness against the SA-8s increased overall as the average survivability for the red entities decreased two percentage points. While the decrease is small enough to be considered inclusive given the number of simulation runs, more importantly, the use of the tactic led to increased survivability for both of the Apaches used in the engagements. The total blue force increase in survivability for the tactic blue forces was a result of the additional firepower brought to the fight in the UAR. While the tactic of flying the UAR closer to the Apache was advantageous, the survivability increase seen in our statistics is resultant of added munitions capabilities programmed into UAR not found on the Blackhawk. Finally, the UAR vehicle's survivability decreased from one scenario to the next when compared to the Blackhawk's performance. However, in theory, this would lead to the removal of the Blackhawk from being flown entirely, in which case there was no human life lost in the executing the communication relay portion of this tactic.

Communication Relay

Type Tactic
 Scenario Name CommTacticTwo.3.gz
 Run Date 4/4/2005
 Scenario Runs 50

Vehicles:

Blue	Red
1008 UAR 1012 AH-64D 1011 AH-64D	1010 SA-8 1009 SA-8

Vehicle ID	Data			Survivability
	Type	Team	# Losses	
1008	UAR	B	8	84.0
1012	AH-64D	B	8	84.0
1011	AH-64D	B	0	100.0
Blue Average				89.3
1010	SA-8	R	13	74.0
1009	SA-8	R	18	64.0
Red Average				69.0

Table 12: Communication Relay Tactic Results

Analysis

In analyzing the use of the converging spiral methodology to develop this tactic, of particular use were points from field manuals that continually made references to the need for such a tactic to be developed. In addition to prior references in the background section that discussed communication problems, FM 1-112 on Attack Helicopter Operations described an even more specific mission with a need for this tactic (sentence underlined for emphasis).

“Pursuit. A pursuit is an offensive operation taken after a successful attack or developed during an exploitation. The pursuit takes advantage of enemy weaknesses and its inability to establish an organized defense. As the enemy attempts to disengage, friendly forces maintain relentless pressure in an attempt to destroy enemy forces completely. A pursuit requires unrelenting pressure, speed, mobility, and firepower to complete the enemy's destruction. The ATKHB is an essential element in the pursuit. As ground forces attempt to maintain contact and flank the enemy, the ATKHB and air assault forces can maneuver deep to cut off the enemy as it attempts to withdraw. The ATKHB and air assault forces also can block entry to relieving enemy forces and can attack retreating enemy forces, which further deteriorates their situation. Repeated attacks by the ATKHB will quicken the disintegration of enemy forces and will destroy their will to fight. C² [Command and Control] during a pursuit is critical. Commanders must coordinate the pursuit by ground forces and the ATKHB to ensure success during a rapidly changing combat environment. Communications may become difficult or be broken. When this occurs,

commanders must act quickly to reestablish communications and ensure coordination between air and ground maneuvers.” [19]

Furthermore, comments from subject matter experts indicated the potential for this tactic to be developed. Both Major Odom and CW4 Gibson mentioned a need for the tactic, and while the scenario simulation took advantage of using the tactic aggressively to aid in communication relay and attacking the enemy, the tactic would also be beneficial in very dull communication relays simply by reducing the workload on pilots involved. With an unmanned vehicle, a pilot is freed from flying the mission, but with autonomy a ground controller is also freed from performing this task. Although more tests and scenarios would have to prove it, the autonomy in this tactic could lead to better relays than a ground controller flying the tactic through remote piloting or a pilot actually performing the mission.

4.6 Screening/Security

The final tactic we present is the manner in which an autonomous rotorcraft would screen, or provide security for a moving element.

Background and Purpose

When friendly ground forces maneuver within hostile territory, aviation assets are frequently used to provide an advance warning capability to the main force. Known as a security mission, the maneuver commander of the main force will use helicopters stationed at strategic positions to not only reconnoiter terrain conditions but also survey possible positions where the main force is particularly susceptible to enemy attacks. In capitalizing on the ability of unmanned vehicles to provide a perpetual “eye in the sky”, this screening/security tactic demonstrates how an autonomous vehicle could properly bolster the safe maneuvering of any advancing ground asset.

Specifically, the US Army Field Manual 17-95 for Cavalry Operations defines that “the primary purpose of a screen is to provide early warning to the main body. It may also destroy enemy recon and impede and harass the enemy” [22]. This definition outlines a potential employment of unmanned rotorcraft as current usage of UAVs has focused on information gathering roles. Particular to aviations role in attack helicopter operations, FM 1-112 defines the manned screening concept in a similar fashion. Specifically, this document states, “the ATKHB [Attack Helicopter Battalion] provides security to friendly forces as they conduct passages of lines, river crossings, air assaults, and as they maneuver in a movement to contact. The types of security it may provide are screen, guard, cover (if augmented), area security, and air assault security (a form of guard). It will position itself where it can make a hasty attack to assist friendly forces to disengage or brush aside enemy forces attempting to disrupt the operation” [19]. To fully understand this last definition, it is beneficial to outline the differences in Army semantics for a screening operation.

The four types of security mission levels differ predominantly in the “degree of protection offered to the main body and the physical characteristics of the operation” according to FM 1-114. The screen, the most basic of the four levels, is the common term to define the tactic whose primary focus is on advance warning and reconnaissance. A guard operation augments the basic screen in preventing direct fire against the main body while still operating within range of indirect-fire weapons. A covering force, however, operates more independently of the unit it protects and is self-contained in its operation. Finally, an area security focuses more on an area to be protected or cleared of enemies than it does on protecting a main force, although it can be assigned this task. These differences are slight, yet the use of an autonomous rotorcraft would likely flank the main force with a screen while using a guard operation to protect the area in front of the main force.

Pilot feedback on use of an autonomous vehicle proved especially advantageous in interpreting the field manuals and outlining this tactic. As seen in the following diagram, it is interpretable that in strictly adhering to the screen tactic description, that no vehicle would be placed in front of an advancing force while executing a screen.

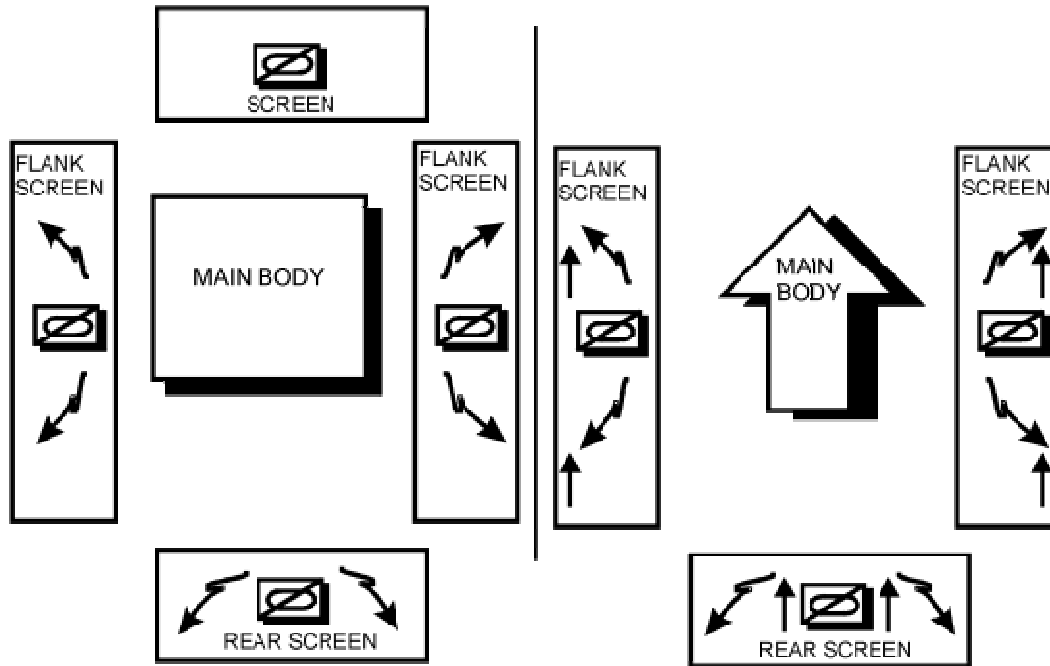

Figure 4.19: Screen Operations ^[20]

However, Major Odom quickly dismissed this pretense by stating, in his opinion, a more effective use of a UAR would be in fact to place the vehicle ahead of the maneuvering force; in most situations the area behind a moving force is already cleared of enemies. If forced to make a decision in placing an autonomous rotorcraft in the sky, his preference would be to enable better data collection with it situated to the front. Incorporating this feedback, the security tactic fuses elements of both a screen and a guard; if an engagement occurred, attack tactics could be called upon to disrupt a force discovered in advance to the front of the main body.

The possibility of an unmanned vehicle performing a screening mission for the Army has also been studied by other researchers. In July of 2003, Army LTC Joseph E. Thome, Jr. wrote a report on whether a UAV possessed the capabilities to potentially replace the Army's Comanche helicopter, which at the time was under development to serve as the Army's premiere armed reconnaissance platform. In his paper for the Army War College, entitled "Unmanned Aerial Vehicles: Replacing the Army's Comanche Helicopter?", LTC Thome evaluates the critical tasks for Reconnaissance, Security, and Movement to Contact missions found in the Army Field Manual, 1-114. In evaluating each of the critical tasks, he applies the following three decision criteria to determine if a UAV can aptly accomplish the task:

- 1) UAVs can accomplish critical tasks requiring sensor capabilities.
- 2) UAVs can accomplish critical tasks executable with pre-launch flight data.
- 3) UAVs cannot accomplish critical tasks requiring visual reasoning.

Based on this criterion, LTC Thome ultimately determines that UAVs can only accomplish 50% of the critical tasks for a security mission. However, he does later assert that

when paired in conjunction with a manned asset, the teaming could very well accomplish 100% of the aviation critical tasks as seen in his chart.

CRITICAL TASKS	UAV	HELICOPTERS	BOTH
	SYSTEMS		
1. Report Reconnaissance information.	YES	YES	YES
2. Find and report all enemy in zone.	YES	YES	YES
3. Reconnoiter all terrain within the area, within the zone along the route, and all terrain that can dominate the area.	YES	YES	YES
4. Determine significant adverse weather	YES	YES	YES
5. Inspect and classify all bridges, overpasses, underpasses, and culverts within the area.	NO	YES	YES
6. Locate a bypass around built-up areas, obstacles, and contaminated areas.	NO	NO	YES
7. Locate fords and crossing sites near all bridges within zone or area.	YES	YES	YES
8. Locate all mines, obstacles, and barriers in the zone within its capabilities.	YES	NO	YES
9. Locate sites for constructing hasty obstacles to impede enemy movement.	NO	YES	YES
10. Reconnoiter all defiles along route for possible ambush sites and locate a bypass.	NO	YES	YES
11. Find suitable covered and concealed air avenues of approach.	NO	YES	YES
12. Maintain continuous surveillance of all battalion-sized avenues of approach.	YES	YES	YES
13. Destroy or repel all enemy reconnaissance and security forces.	NO	YES	YES
14. Perform reconnaissance along the main body's axis of advance.	YES	YES	YES
15. Locate the lead elements of the enemy order of battle.	NO	YES	YES
16. Maintain contact with the enemy order of battle report their activities, and harass the enemy while displacing.	NO	YES	YES
17. Maintain contact with the lead combat element of the friendly force.	YES	YES	YES
18. Reconnoiter the zone between the main body and the guard force battle positions.	YES	YES	YES
19. Defeat, repel, or fix enemy ground forces before they engage the main body with direct fire.	NO	YES	YES
20. Reconnoiter forward or to the flanks of ground forces.	YES	YES	YES
21. Harass and impede enemy elements	NO	YES	YES
22. Direct ground elements to the vicinity of enemy units and support friendly ground forces with direct fires.	NO	YES	YES
23. Maintain surveillance of enemy forces.	NO	YES	YES

Figure 4.20: Capable Execution of FM 1-114 Critical Tasks ^[58]

His eventual conclusion that the UAV could not fully accomplish all the tasks that an unmanned helicopter is accurate; the situational awareness that on-scene personnel bring to an engagement would be extremely difficult to replicate in machines. Furthermore, LTC Thome states in particular that unmanned vehicles would never be able to “harass and impede enemy elements.” However, by arming unmanned helicopters, there exists the possibility of using autonomous rotorcraft offensively and thus being able to harass an enemy element. The arming of UAVs was also recognized by the Army as a way to replace UAVs; ultimately, the Comanche program was cancelled with one of the cited reasons being able to shift more money into autonomous vehicles. Nevertheless, LTC Thome’s assessment that a teaming of manned and

unmanned helicopters could accomplish all the critical security tasks necessary speaks to the capability of an unmanned rotorcraft screening for a main force.

In addition, Major David W. Barnes tackled a similar issue in his Master's thesis for the U.S. Army Command and General Staff College. Major Barnes focused more on the specific armed reconnaissance role of the Comanche being replaced by UAVs, he included in his work an opinion that screening missions are "ideally suited" for an unmanned system. He asterisked his statement though by asserting that bandwidth problems in sending feeds from multiple helicopters to one maneuver commander may curtail the effectiveness of this tactic [4]. Regardless, even with technical difficulties in sending feeds, the following recent story from a Technology Review article on Operation Iraqi Freedom illustrates a need for a screening tactic.

On April 3rd, 2003 Lieutenant Colonel Earnest Marcone attempted to lead his battalion of armored vehicles towards a key bridge near the Euphrates River [56]. However, completely unaware of the size of the enemy force on the other side of the bridge, Marcone was forced to fight a battle unable to take advantage of surveillance technology and engaged Iraqi tanks in battles paralleling World War II. The engagement was eventually a success; however, a lack of proper intelligence failed Marcone in what was later established to be one of the biggest counter attacks by Iraqi forces in the war. Despite facing over 25 to 30 Iraqi tanks and 70 to 80 armored personnel carriers, Marcone stated that for advanced warning purposes concerning the location of the Iraqis, he had "nothing until they slammed into us." LTC Marcone simply never received the reconnaissance information he needed. A small screening force of autonomous helicopters in advance and on the flanks of Marcone's unit could have reported directly to him the engagement he was soon to face.

Statechart

The screening tactic is perhaps one of the least event intensive of the tactics described; at a basic level involves protecting a main force as they travel through a specific hostile region. Nevertheless, there exist some key states that should be executed in the performance of this tactic in an autonomous vehicle.

Flank/Rear/
Forward Screen

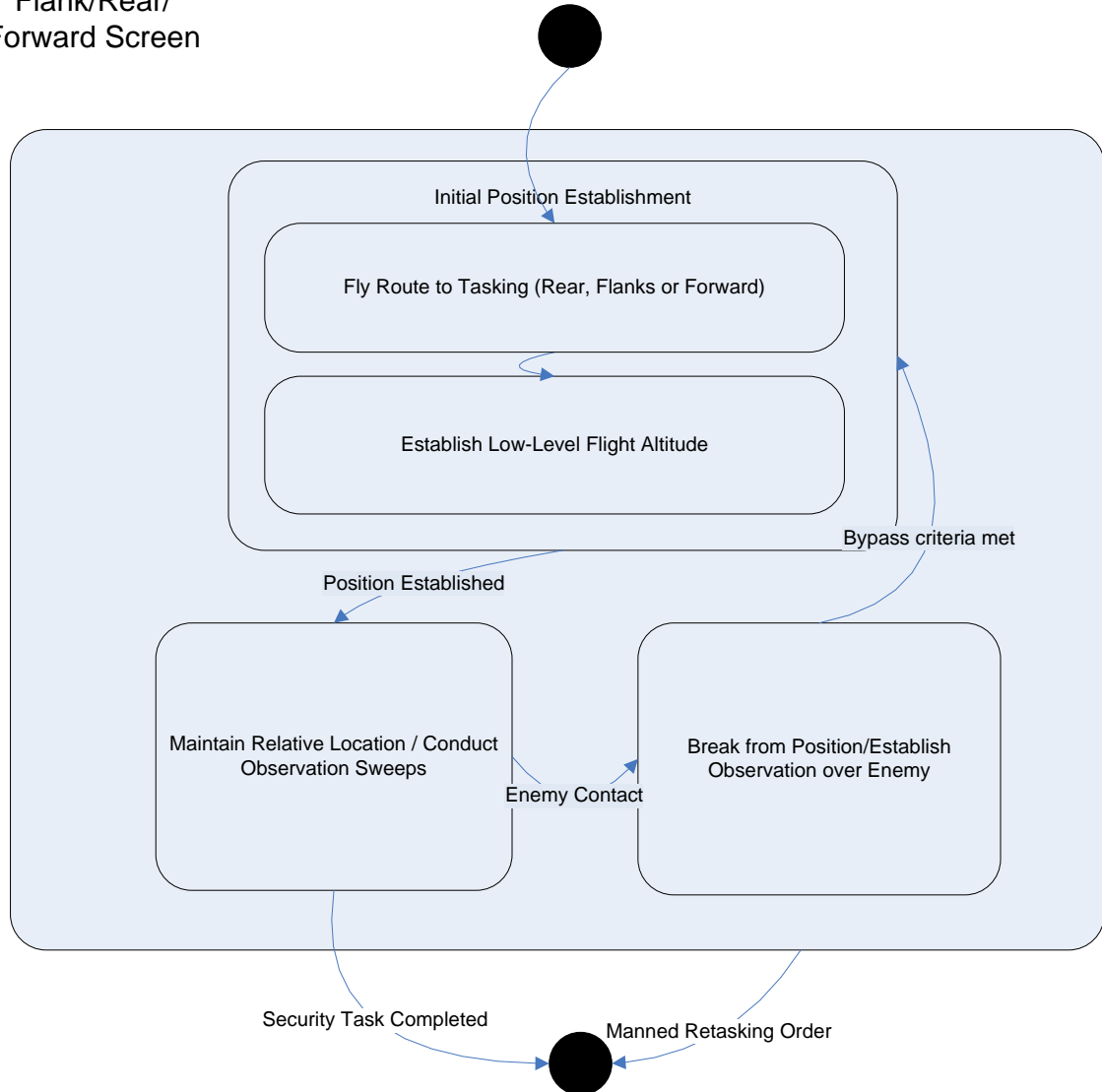

Figure 4.21: Screening Statechart

The initial event, and perhaps most important, is the relative position of where the autonomous rotorcraft should situate itself relative to the main force they are screening/guarding. However, as there are too many variables that influence the nature of the screening mission, exact altitudes and lateral distances cannot be given. In talking with Captain Myers, though, he cited that biggest factor would be the terrain [36]. As an example, Captain Myers stated that if a screen were executed over a city or more densely populated area, when protecting your main force “you might be right on top of them.” He continued saying that “in the desert, you can give a kilometer to two kilometers” distance. Therefore, the parameters of where exactly a screening UAR would fly should be for the maneuver commander to set based on his criteria.

After setting the lateral distance, the commander could also set the vertical separation above ground for the helicopters. As seen in the statechart, though, the recommendation would be to take advantage of the sensors on board the autonomous rotorcraft and fly it at a high enough picture to fully benefit the maneuver commander. The low-level flight altitude takes

advantage of the highest pre-established Army elevation as referenced throughout its field manuals. However, the commander could choose to place it upwards of 1000 feet.

After establishing its relative position away from the main force, the next event the UAR would transition into is an overwatch position. In this state the majority of the maneuver occurs and through this the helicopter maintains its sight picture on the terrain below. Observation sweeps are conducted based on the number and coverage provided by the rotorcraft, yet optimally observation sweeps could range from anything as simple as 180 degree side to side sweeps in front of the helicopter to full figure eight movements to reconnoiter the entire existing terrain.

While remaining in the statechart event of screening for the main force, there lie two possibilities that could transition out of the tactic. The first is simply the end of the mission in which the convoy or maneuver force reaches its final destination. The second however, involves whether enemy contact was made with the enemy. As explained by Captain Myers, there often exists some pre-determined “bypass criteria” that the commander sets out in advance [36]. Often it is as simple as “if an enemy element of three people or less, we bypass” if, as an example, the friendly unit was an armored column and therefore the three individuals would pose little threat. If the bypass criteria, however, are not met then the initial state would be to establish an overwatch above the enemy force to establish proper reconnaissance. As stated in FM 1-114 referring to screening operations, “once gained, contact is maintained to ensure a continuous flow of combat information. Contact is never broken unless specifically directed by the commander.” If this is the instance, then the UAR would wait for manned guidance which could involve initiation of a popup fire or running fire attack or a bypass command that then places the vehicle back in its original position.

Scenarios

To test the security/screening tactic of our UAR, we again constructed two scenarios labeled as the baseline and the tactical scenario. Our baseline scenario represents one manner in which screening is currently performed by manned assets in hostile territory. Based on the likelihood of enemy contact, helicopters can employ various traveling techniques. If the probability of encountering enemies is high, helicopters will employ a tactic called bounding overwatch. In using this tactic, helicopters will literally bound over top of or beside each other to enable one helicopter to move while the other protects its movement from an overwatch position. When performing screening or security missions in high-threat areas, it is not uncommon for helicopters to perform this maneuver as seen in Figure 4.22 to protect the flanks of an advancing force.

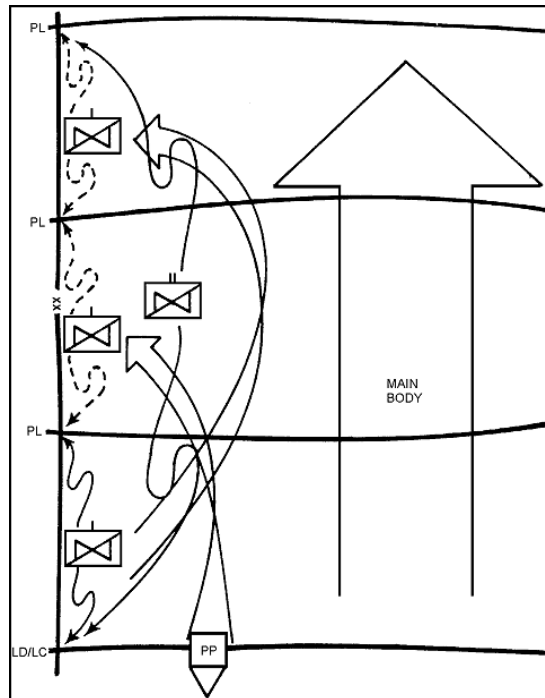

Figure 4.22: Bounding Overwatch Flank Screen [20]

The baseline scenario was constructed to mirror the screening tactic in Figure 4.22 by placing two AH-64D Longbow Apaches on a security mission to protect a main force of four M1A1 main battle tanks. The Apaches were tasked to screen for the tanks by performing bounding overwatch along side and overtop of the advancing column as the main force maneuvered between two hills en route to a final destination. However, on the other side of the pass between the two hills, two platoons of Russian T-80 tanks were placed to simulate an ambush. The scenario layout with the Apache's to the left of the picture performing their first bound can be seen in Figure 4.23.

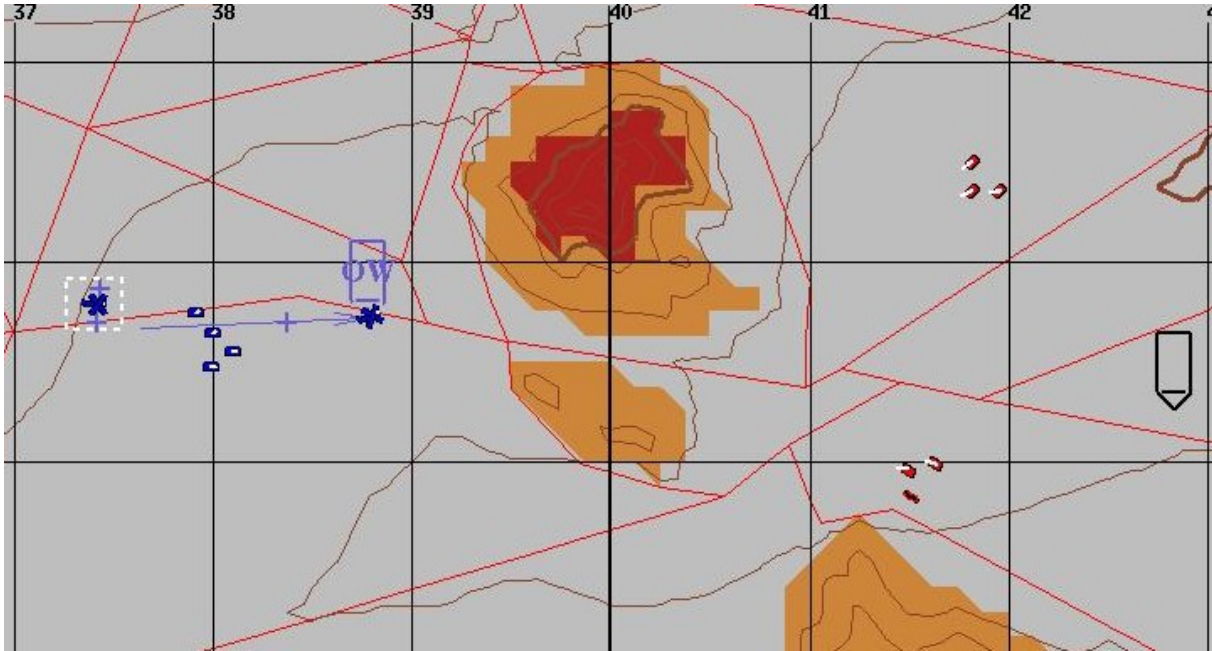

Figure 4.23: Security Baseline with Bounding Overwatch

To capitalize on the UAR's ability to perform tactics more perilous than manned assets, two UAR vehicles replaced the AH-64Ds in the tactical scenario. In addition to the replacement of the vehicles, though, the UAR vehicles were instead assigned the statechart tactic which placed them both at the "low level" flight altitude in protection of the main moving force. The low level flight altitude, the highest defined altitude for helicopter travel is typically reserved for movements in which enemy contact is unexpected. However, for our tactical scenario, the UARs were placed at this altitude for their ability to handle more dangerous assignments. A scene from this scenario in which the UAR vehicles are already engaging the enemy tanks is seen in Figure 4.24.

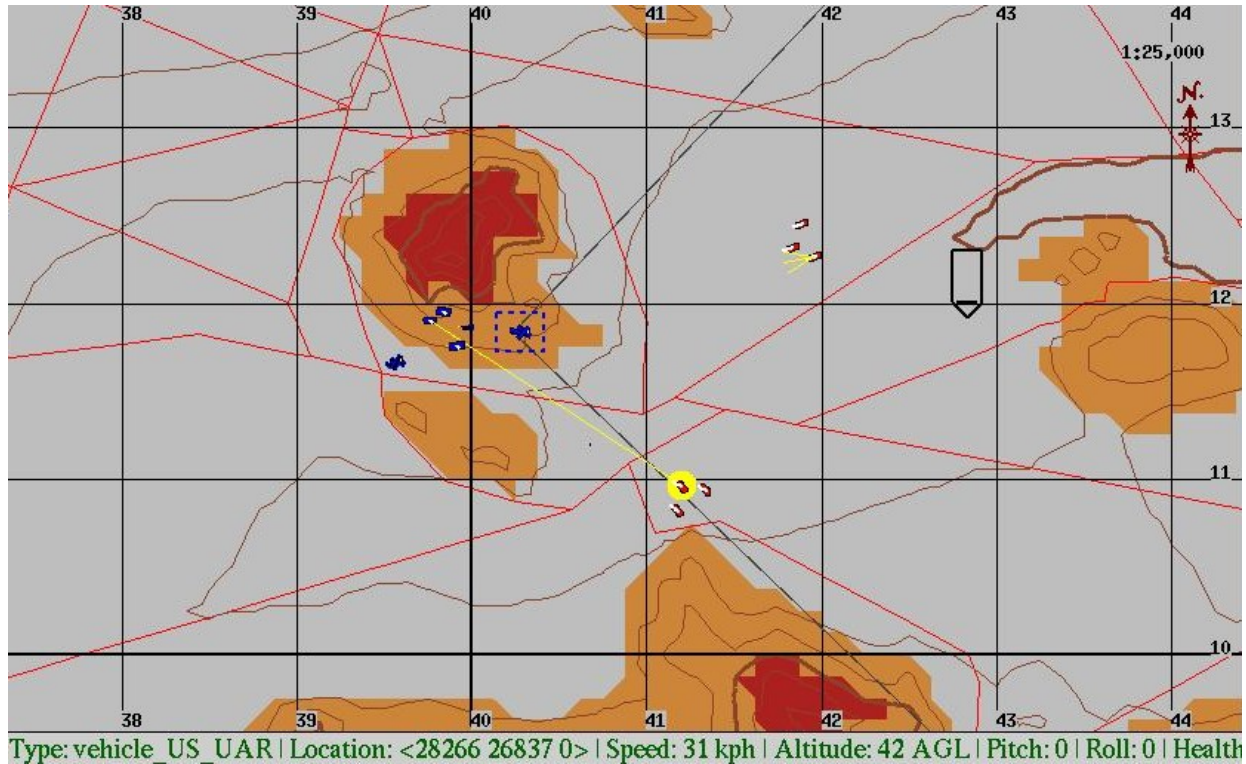

Figure 4.24: UAR Security Tactic in Engagement

The overall expected result of these scenarios is that the use of the autonomous rotorcraft tactic will improve the survivability of the main advancing force by providing advanced warning from its low level flight position. The hypothesis is that by not having to perform bounding overwatch like a manned helicopter might, the M1A1 tanks will have advanced warning of the engagement. Furthermore, the armed UARs will be beneficial in reducing the combat effectiveness of the enemy by firing missiles earlier at the enemy T-80 tanks. This will hopefully boost the survivability of the M1A1 tanks and validate the effectiveness of the tactic.

Results & Analysis

Overall, the results of the baseline and tactical scenario corresponded to those hypothesized. In the baseline scenario involving the AH-64D Apaches performing NOE bounding overwatch, the red forces achieved a higher overall survivability, although only by a small percentage (38.3% to 37.3%) as seen in Table 13. As neither side was adequately warned of the other's advance until both were within firing range, each team's survivability being so low is not unusual. Furthermore, the fact that the variance between each entity's survivability was so great is not surprising either; vehicle 1031, an AH-64D, only survived one of the engagements unharmed. However, this helicopter was the lead bounding vehicle at the instance when the dug in T-80s were first discovered which explains its extremely low survivability.

Screening/Security

Type Baseline
Scenario Name SecBaseOne.6.gz
Run Date 3/31/2005
Scenario Runs 50

Vehicles:

Blue		Red	
1033	M1-A1	1027	T-80
1028	M1-A1	1023	T-80
1029	M1-A1	1026	T-80
1030	M1-A1	1025	T-80
1032	AH-64D	1022	T-80
1031	AH-64D	1024	T-80

Vehicle ID	Data			Survivability
	Type	Team	# Losses	
1033	M1-A1	B	36	28.0
1028	M1-A1	B	29	42.0
1029	M1-A1	B	14	72.0
1030	M1-A1	B	24	52.0
1032	AH-64D	B	36	28.0
1031	AH-64D	B	49	2.0
Blue Average				37.3
1027	T-80	R	48	4.0
1023	T-80	R	45	10.0
1026	T-80	R	46	8.0
1025	T-80	R	12	76.0
1022	T-80	R	18	64.0
1024	T-80	R	16	68.0
Red Average				38.3

Table 13: Screening Baseline Results

For the tactical scenario, the use of the UAR tactic did increase the blue team's overall survivability while also increasing its relative survivability against the red forces. The blue forces survivability increased from 37.3% to 81.3%, but more significant was the much greater improvement for both of the UAR vehicle scores. In the baseline scenario, the two vehicles averaged 42.5 losses in the 50 runs while only experiencing 7 losses on average in the tactical scenario. The increase in survivability for both forces between scenarios runs was resultant of a reaction to contact capability within OneSAF that altered the behaviors of the vehicles and thus lead to limited engagements. Nevertheless, these preliminary results do point to the potential effectiveness of utilizing this tactic in an autonomous rotorcraft.

Screening/Security

Type Tactic
Scenario Name SecTacticThree.2.gz
Run Date 3/31/2005
Scenario Runs 50

Vehicles:

Blue		Red	
1029	M1A1	1028	T-80
1018	M1A1	1025	T-80
1022	M1A1	1026	T-80
1027	M1A1	1023	T-80
1024	UAR	1019	T-80
1021	UAR	1020	T-80

Vehicle ID	Data			Survivability
	Type	Team	# Losses	
1029	M1A1	B	15	70.0
1018	M1A1	B	6	88.0
1022	M1A1	B	12	76.0
1027	M1A1	B	9	82.0
1024	UAR	B	9	82.0
1021	UAR	B	5	90.0
Blue Average				81.3
1028	T-80	R	24	52.0
1025	T-80	R	24	52.0
1026	T-80	R	23	54.0
1023	T-80	R	13	74.0
1019	T-80	R	10	80.0
1020	T-80	R	15	70.0
Red Average				63.7

Table 14: Screening Tactical Results

Analysis

In evaluating the effectiveness of the methodology in developing this tactic, the field manuals provided excellent background in understanding the emphasis the Army places on protecting advancing forces. As explained in the background section, the four classifications of providing security allow communication between elements of expectations for the mission's conduct. Furthermore, the Air Calvary Operations manual described a need for this tactic by indicating that in hostile areas, manned assets can typically perform the maneuver by bounding overwatch and thus being able to provide less coverage. In this light, the more aggressive autonomous agent might be better able to protect friendly forces, although the ground commander's comfort with being protected by unmanned assets is a concern that would need addressing.

It is important to note that the employment of this tactic may not be far away. In a March 2005 article, the author discusses how the Israeli military is using one method to send UAV visual images directly to the ground forces [3]. Using "Dick Tracy" technology, the visual feeds are sent to soldiers on LCD screens three inches in size that fit on the soldier's wrist. With wrist

watch pictures of over the hill forces, the feeds are being described as shortening the time commanders need to identify and strike targets from twelve minutes down to seconds. This capability could prove extremely useful in a screening tactic. In relating to our simulation scenario, the lead tank commander in our column could receive a visual picture on his wrist, and then evaluate at that stage whether the entrenched T-80 tanks were too strong for his force to engage. Furthermore, this capability might have been particularly useful to LTC Marcone in his engagement described in the background section. If his unit could have employed a few UAR vehicles, this would have enabled *him* to receive the necessary information detailing the expected size of the Iraqi counter attack.

[This Page Intentionally Left Blank]

Chapter 5 Summary and Future Work

This thesis has presented a methodology for developing tactics in autonomous single-vehicle rotorcraft. Our methodology utilized a three-pronged approach of using field manuals, interviews with subject matter experts and simulation and testing to develop six tactics potentially useful in the programming of future autonomous vehicles. To aid in understanding the tactics and also key events and transitions that occur, the tactics were presented in a visual formalism called statecharts. While the statecharts and tactics focused on helicopters as the medium, it is entirely feasible the methodology could also be applied to fixed-wing aircraft.

In concluding this thesis we present a summary of the material contained herein and ideas for future work.

5.1 Thesis Summary

In Chapter 1, we introduced evidence for the growing trend of unmanned vehicles in military operations. This thesis also covered the fervor with which United States companies are researching and developing UAVs to support their growing inclusion in each of the armed services. Most importantly, though, Chapter 1 framed the problem of understanding how autonomy will likely play an increasing role in UAV operations; in this light, we posed the need to develop tactics and behaviors that control a vehicle as it executes autonomous maneuvers. Finally, we presented the question this research intended to answer and outlined our objective in delivering a multifaceted methodology that develops potentially advantageous autonomous tactics.

In Chapter 2, background evidence showed the relevance this work brings as war planners expand the missions UAVs perform. Initially, research covered a brief history of UAVs before presenting information on several of the UAVs currently fielded by the services. Also in this section, this thesis discussed the limited missions currently performed by many UAVs before highlighting some autonomy programmed within each of the vehicles. Afterwards, we discussed two current defense programs seeking to build autonomy into UAVs. The J-UCAS and UCAR programs were cited as evidence towards an initial movement to adopt UAVs needing less human control and interaction. Afterwards, we presented a hierarchy of autonomous planning to show the different levels of automation in vehicle control. This section enabled us to convey how we define tactics in relation to how autonomy might also control a vehicle. Finally, prior research into other tactics development was covered to show that qualitative means have been predominantly utilized to advance tactics research.

Chapter 3 explained our converging spiral methodology and covered all aspects of the design in detail. Initially we outlined the iterative design of the methodology before discussing specific ways we envisioned the research to be advantageous in answering our question. Afterwards, we discussed our research into field manuals before outlining the subject matter experts and the added benefit they brought to the process. The thesis then discussed Harel's statecharts and key differences between them and state-transition diagrams. In addition, this section covered how the statecharts would be beneficial in representing behaviors and also why a

visual method is important at all to represent military tactics. Finally, this section concluded with a review of other simulations that have developed tactics before presenting why simulation was chosen in our design methodology. We finished with a presentation of the simulation chosen in our three-pronged methodology and the modifications made to it for the purpose of performing thesis research.

In Chapter 4, we applied the methodology presented in the prior chapter to develop six autonomous rotorcraft tactics. In each of the tactics, the background and purpose of the tactics was presented first, drawing heavily on SME comments and information pulled from research into Army field manuals. Afterwards, we presented the statechart and discussed the key events and transitions that would occur in the execution of the behavior. The tactic was then simulated in our Army simulation tool, OneSAF, to draw inferences about the tactic's feasibility and potential benefit to be used in an engagement. Each of the six tactics (running fire, popup fire, laser designator, forward tether, communication relay, and security) concluded with a discussion of the methodology influence on the tactic.

5.2 Future Work

In addition to the work presented herein, this section discusses possibilities for future work branching off the research espoused in this thesis.

Observing/Parsing output from SMEs

One possible adaptation of the methodology entails using the subject matter experts in a more involved method. When interviewing pilots about the tactics they perform, in essence you add an additional step to the process of transferring information. Pilots must interpret the actions they perform first, translate them, and then convey them to researcher. While a pilot is fully aware of the actions he performs and is more qualified than anyone to describe what he does, it is in the tactic's interpretation by the researcher that can lead to distortion. In this thesis, feedback was taken from pilots via the statecharts to correct for a possible translation distortion, however it may be beneficial to eliminate this step. Instead of interviewing SMEs, the researcher could observe the different actions of a pilot in a simulator and then draw up what he conveys as the predominant states and transitions. Then, the researcher could use the pilot to correct any major discrepancies in what the operator intended to do and how the researchers perceived his actions (drew the statechart). This methodology would still lead to some distortion; however the discrepancies could be less as it eliminates a step of the process.

Taking it a step further, the researcher could also design quantitative parameters in an experiment to directly translate behaviors. Research could again place a pilot in a simulator; however this time it could parse output from his actions to directly quantify his actions. This research would be adapting the work presented by Fernlund and Gonzalez outlined in Chapter 3 [16]. However, a potential drawback is that this method presents limits in automating *unmanned* tactics. By parsing output from a human, it might force the research to make a 1:1 translation and simply assume that unmanned vehicles should behave exactly like manned assets. Overcoming this hurdle would prove difficult; at a minimum unmanned aircraft can be designed

to withstand higher gravitational forces. It can also be generally assumed that pilots are more risk-adverse in dangerous situations than UAVs.

Exploring Tactics as a System in Statecharts

Another possibility for future research would entail exploring the statecharts capability of adding depth to a tactic. The tactics presented in this thesis all occurred at a single level, yet future research might explore a tactic as a system. In doing so, we present the following example that shows a level one higher than our statechart of the running fire tactic.

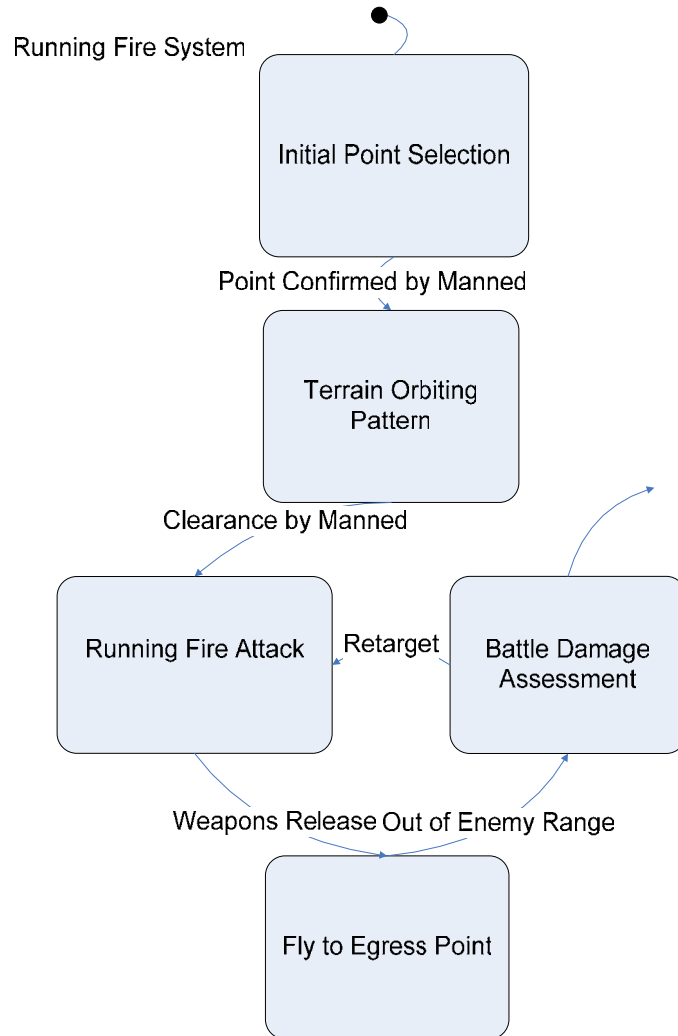

Figure 5.1: Running Fire Attack System

In this statechart, we show the events and transitions that could occur prior to the running fire attack. Each of the above events could be broken down to show a full system representation of all the events within it, much like Harel’s complete representation of his watch [17]. In this example, we show several of the events that lead up to the running fire tactic presented in this thesis (third state down – “Running Fire Attack”). Other tactics could be developed in a similar

light and an entire network of interacting statecharts could be developed. In this light, an entire system would be created in which many states might overlap and be used for several different tactics.

Exploring additional tactics

Another area for future research would entail exploring additional tactics through either the methodology used in this thesis or a different one. With advances in technology, more capabilities will come to unmanned vehicles that will enable them to perform tactics not considered within this thesis and perhaps not even feasible at the present moment. One idea is to explore less aggressive tactics that would require scoring simulations in a way other than a vehicle's survivability. As an example, one tactic that could be developed would be a show of force mission behavior. Field Manuals already describe the tactic as seen in the following description found in the Air Calvary Operations Field Manual: "The squadron may be called upon to enhance C² or fly missions whose intent is purely psychological (i.e., dropping leaflets, show of force, loud speaker platform, etc.). Other missions whose intent is purely tactical can produce residual psychological effects" [20]. Furthermore, Captain Myers described incidents in Iraq where show of force was used to, "let the insurgents know we were still there," and this non-engagement designed tactic, among others, could be explored in having unmanned rotorcraft automate the "dull, dumb, and different" types of tactics UAVs are well suited for.

Multi-Vehicle Tactics

A final idea for potential work would entail exploring the tactics particular to multi-vehicle rotorcraft mission. While this thesis focused more on single vehicles and how they could execute particular objectives, future research could tackle how teams of varying sizes could effectively reconnoiter an area or engage a sizeable force of surface to air missiles, for example. A similar methodology to the one used in this thesis could be implemented; however, field manuals and SMEs would be read and studied more to see how companies or battalions of helicopters engage forces.

Appendix A: Glossary of Terms

AO	Area of Operations
ABF	Attack by Fire
AGL	Above Ground Level
AMBL	Air Maneuver Battle Lab
ARDEC	Armament Research Development and Engineering Center
ATM	Aircrew Training Manual
AWACS	Airborne Warning and Control System
DARPA	Defense Advanced Research Project Agency
ETL	Effective Translational Lift
FCR	Fire Control Radar
HSKT	Hunter Standoff Killer Team
J-UCAS	Joint Unmanned Combat Air System
LOS	Line of Sight
MANPADS	Man Portable Air Defense System
NOE	Nap of the Earth
OTB	OneSAF Testbed Baseline
OneSAF	One Semi-Automated Forces
RPG	Rocket Propelled Grenade
RF	Radio Frequency
SAL	Semi-Active Laser
SME	Subject Matter Expert
TTPs	Techniques, Tactics, and Procedures
UAR	Unmanned Autonomous Rotorcraft
UAV	Unmanned Aerial Vehicle
UCAR	Unmanned Combat Armed Rotorcraft

References

- [1] “AGM-114 Hellfire.” Janes.com. 13 Oct. 2000. Jane’s Information Group. 7 Mar. 2005 <http://www.janes.com/defence/air_forces/news/jalw/jalw001013_1_n.shtml>.
- [2] “AH-64A Operations.” GlobalSecurity.org. 7 Mar. 2005 <<http://www.globalsecurity.org/military/systems/aircraft/ah-64a-ops.htm>>.
- [3] Associated Press. “Israeli Forces Using High-Tech Video Tools.” 6 Mar. 2005.
- [4] Barnes, David W. Considerations for the Maneuver Commander: Could the Emergence of Unmanned Aerial Vehicles Spell the Demise of the Army’s RAH-66 Comanche in the Armed Reconnaissance Roles? MA thesis. U.S. Army Command and General Staff College. 2003.
- [5] “Boeing AH-64 Apache.” Janes.com. 13 Oct 2000. Jane’s Information Group. 28 Feb 2005 <http://www.janes.com/defence/air_forces/news/jawa/jawa001013_1_n.shtml>.
- [6] Brittingham, Michael L. Attack Helicopter Employment Options. MA thesis. U.S. Army Command and General Staff College, 1980.
- [7] “Canard Rotor/Wing Flight Demonstration.” Defense Advanced Research Project Agency. 3 Apr. 2004. 26 Jan. 2005 <<http://www.darpa.mil/tto/programs/crw.html>>.
- [8] Cantrell, Mark. “The Pilot Who Wasn’t There.” Military Officer. 2 Mar 05 <http://www.moaa.org/Magazine/CurrentEdition/f_pilot.asp>.
- [9] Charles, John. “CMU’s Autonomous Helicopter Explores New Territory.” IEEE Intelligent Systems. Sep.-Oct. 1998: 85-87.
- [10] Chenault, Rich. “AH-64 Operations in Afghanistan.” Helis.com 20 Mar. 2005 <<http://www.helis.com/stories/ah64afgh.php>>.
- [11] Dever, Chris et al. “Trajectory Interpolation for Parameterized Maneuvering and Flexible Motion Planning of Autonomous Vehicles.” AIAA Guidance, Navigation and Control Conference and Exhibit. Aug. 2004.
- [12] “Dragon Eye.” GlobalSecurity.org 6 Apr. 2005 <<http://www.globalsecurity.org/intell/systems/dragon-eye.htm>>.
- [13] “Dragon Warrior / Cypher II.” GlobalSecurity.org. 6 Apr. 2005 <<http://www.globalsecurity.org/intell/systems/dragon-warrior.htm>>.
- [14] Garamone, Jim. “From the US Civil War to Afghanistan: A Short History of UAVs.” DefendAmerica.mil. Apr. 2002. 29 Mar. 2005 <<http://www.defendamerica.mil/articles/apr2002/a041702a.html>>.
- [15] Gibson, Terry. Personal Interview. 21 Sep. 2004.
- [16] Gonzalez, Avelino and Hans Fernlund. “Evolving Models of Human Behavior Representation from Observation of Human Performance in a Simulator.” 2004 Conference on Behavior Representation in Modeling and Simulation (BRIMS). 2004.
- [17] Harel, David. “Statecharts: A Visual Formalism for Complex Systems.” Science of Computer Programming. June, 1987: 231-274.
- [18] Headquarters, Department of the Army. Aircrew Training Manual: Attack Helicopter – AH-64D. Apr. 2000.
- [19] Headquarters, Department of the Army. FM 1-112: Attack Helicopter Operations. 2 Apr. 1997.

- [20] Headquarters, Department of the Army. FM 1-114: Air Calvary Operations. Apr. 2000.
- [21] Headquarters, Department of the Army. FM 1-140: Helicopter Gunnery. 29 Mar. 1996.
- [22] Headquarters, Department of the Army. FM 17-95: Calvary Operations. 24 Dec. 1996.
- [23] Heath, Garrett D. Simulation Analysis of Unmanned Aerial Vehicles (UAV). MS thesis. Naval Postgraduate School, 1999.
- [24] "Helicopters strike targets around Karbala." Milwaukee Journal Sentinel Online. 28 Mar. 2004. 1 Mar. 2005 <<http://www.jsonline.com/news/gen/mar03/129415.asp>>.
- [25] "High Times." Economist.com. 11 Dec. 2003. The Economist. 14 Apr. 2004 <http://www.economist.com/displaystory.cfm?story_id=2282185>.
- [26] Hill, Randall W. et. al. "Intelligent Agents for the Synthetic Battlefield: A Company of Rotary Wing Aircraft." American Association for Artificial Intelligence. 1997.
- [27] Homer, Mark. "A Quantitative Approach for Determining the Level and Sophistication of Automation in Unmanned Vehicles." Association for Unmanned Vehicle Systems International 2003.
- [28] "Hunter RQ-5A Tactical Unmanned Aerial Vehicle, USA/Israel." army-technology.com. 30 Mar. 2005 <<http://www.army-technology.com/projects/hunter/>>.
- [29] "Joint Unmanned Combat Air System J-UCAS Overview." Defense Advanced Research Project Agency. 31 Mar. 2004. 26 Jan. 2005 <http://www.darpa.mil/j-ucas/fact_sheet.htm>.
- [30] J-UCAS Homepage. 12 Apr. 2005 <<http://www.darpa.mil/j-ucas/>>.
- [31] "J-UCAS Overview." Defense Advanced Research Project Agency. 30 Mar. 2005 <http://www.darpa.mil/j-ucas/fact_sheet.htm>.
- [32] MacWillie, Stephen. et. al. "Comanche Analysis of Alternatives: UAVs Studies and Analysis Summary." Air Maneuver Battle Lab. Fort Rucker, AL. Mar. 2000.
- [33] Maddock, Ian. "The Battle for UCAR." Vertiflite. Fall 2004. p. 40-50. <<http://www.vtol.org/pdf/ucarvertfall04.pdf>>.
- [34] Mazarella, Mark N. Adequacy of U.S. Army Attack Helicopter Doctrine to Support the Scope of Attack Helicopter Operations in a Multi-Polar World. MA thesis. U.S. Army Command and General Staff College. 1994.
- [35] Myers, Kevin. Personal Interview. 21 Sep. 2004.
- [36] Myers, Kevin. Phone Interview. 22 Feb 2005.
- [37] O'May Janet, et al. "OneSAF Killer Victim Scoreboard Capability for C2 Experimentation." 2002 Command and Control Research and Technology Symposium. 11 June 2002.
- [38] Odom, Michael. Personal Interview. 15 Jan. 2005.
- [39] Odom, Michael. Phone Interview. 24 Feb 2005.
- [40] Office of the Chairman of the Joint Chiefs of Staff. Joint Pub 3-55.1: Joint Tactics, Techniques, and Procedures for Unmanned Aerial Vehicles. 27 Aug. 1993.
- [41] Onley, Dawn S. "Army combining war game simulation into single app." Government Computer News. 7 June 2004 <http://www.gcn.com/23_13/web/26106-1.html>.
- [42] Peck, Ted. Basic Combat Skills: Tactics Flashcards. 2003.
- [43] Pettit, Ryan L. Low Altitude Threat Evasive Trajectory Generation for Autonomous Aerial Vehicles. MS thesis, Massachusetts Institute of Technology, June 2004.
- [44] "Pioneer Short-Range (SR) UAV." Federation of American Scientists. 5 Mar. 2000. 5 Apr. 2005 <<http://www.fas.org/irp/program/collect/pioneer.htm>>.

- [45] “Predator Achieves IOC in Iraq.” Association for Unmanned Vehicle Systems International. Mar. 2005. 30 Mar. 2005 <<http://www.auvsi.org/news/index.cfm>>.
- [46] “RPG-7 / RPG-7V / Antitank Grenade Launcher; Specifications.” GlobalSecurity.org 1 Mar 2005 <<http://www.globalsecurity.org/military/world/russia/rpg-7-specs.htm>>.
- [47] “RQ-1 Predator MAE UAV.” Federation of American Scientists. 6 Nov. 2002. 12 Apr. 2005 <<http://www.fas.org/irp/program/collect/predator.htm>>.
- [48] “RQ-4A Global Hawk (Tier II+ HAE UAV)” GlobalSecurity.org 6 Apr. 2005 <http://www.globalsecurity.org/intell/systems/global_hawk.htm>.
- [49] “RQ-7 Shadow 200 Tactical UAV” Global Security.org. 30 Mar. 2005 <<http://www.globalsecurity.org/intell/systems/shadow.htm>>.
- [50] “SA-18 Grouse Iгла 9k38: Specifications.” GlobalSecurity.org. 1 Mar. 2005. <<http://www.globalsecurity.org/military/world/russia/sa-18-specs.htm>>.
- [51] “SA-8 GECKO / 9K33 Osa.” GlobalSecurity.org. 7 Apr. 2005 <<http://www.globalsecurity.org/military/world/russia/sa-8.htm>>.
- [52] Science Applications International Corporation. One Semi-Automated Forces (OneSAF) Testbed Baseline (OTB) Developer’s Course Workbook. 31 Jan. 2002.
- [53] Smith, Tyler. Personal Interview. 9 Feb. 2005.
- [54] Surdu, John R. “OneSAF Program Overview.” Apr. 2004 <http://www.onesaf.org/Large_Common_Brief.pdf>.
- [55] Talbot, David. “The Ascent of the Robotic Attack Jet.” Technology Review.com Mar. 2005.
- [56] Talbot, David. “We Got Nothing Until They Slammed into Us.” Technology Review. Nov. 2004. pg. 36-45.
- [57] The Probert Encyclopedia – Weapons and Warfare (1-A).” Federation of American Scientists. 1 Mar 2005. <<http://www.fas.org/news/reference/probert/F1.HTM>>.
- [58] Thome, Joseph E. Jr. Unmanned Aerial Vehicles: Replacing the Army’s Comanche Helicopter? U.S. Army War College Strategy Research Project. U. S. Army War College. 2003.
- [59] Training and Doctrine Command, Department of the Army. Aircrew Training Manual: Attack Helicopter, AH-64D. Dec. 2000.
- [60] “UCAR Overview.” Defense Advanced Research Project Agency. 15 Aug. 2004 <http://www.darpa.mil/tto/programs/UCAR_overview.pdf>.
- [61] “Unmanned Combat Armed Rotorcraft.” GlobalSecurity.org. 30 Mar. 2005 <<http://www.globalsecurity.org/military/systems/aircraft/ucar.htm>>.
- [62] Various Designers. Draper Laboratory Control, Information and Decision Systems Division. 8 Apr. 2005.
- [63] “Vehicles.” UAV Forum. 26 Jan. 2005 <<http://www.uavforum.com/vehicles/vehicles.htm>>.
- [64] “VTUAV Fire Scout.” Northrop Grumman. 30 Apr. 2005 <http://www.is.northropgrumman.com/products/navy_products/vtuav/vtuav.html>.
- [65] Wells, Michael. Personal Interview. 21 Sep. 2004.