



**A SYSTEMS ARCHITECTURAL MODEL FOR MAN-PACKABLE/OPERABLE
INTELLIGENCE, SURVEILLANCE, AND RECONNAISSANCE
MINI/MICRO AERIAL VEHICLES**

THESIS

Cory A. Cooper
Captain, USAF

Matthew L. Ewoldt
Captain, USAF

Steaven A. Meyer
Captain, USAF

Edward W. Talley
Second Lieutenant, USAF

AFIT/ENY/GSE/05-M02

DEPARTMENT OF THE AIR FORCE
AIR UNIVERSITY

AIR FORCE INSTITUTE OF TECHNOLOGY

Wright-Patterson Air Force Base, Ohio

APPROVED FOR PUBLIC RELEASE; DISTRIBUTION UNLIMITED

The views expressed in this thesis are those of the authors and do not reflect the official policy or position of the United States Air Force, Department of Defense, or the United States Government.

AFIT/ENY/GSE/05-M02

A SYSTEMS ARCHITECTURAL MODEL FOR MAN-PACKABLE/OPERABLE
INTELLIGENCE, SURVEILLANCE, AND RECONNAISSANCE
MINI/MICRO AERIAL VEHICLES

THESIS

Presented to the Faculty
Department of Aeronautics and Astronautics
Graduate School of Engineering and Management
Air Force Institute of Technology
Air University
Air Education and Training Command
in Partial Fulfillment of the Requirements for the
Degree of Master of Science in Systems Engineering

Cory A. Cooper, BS
Captain, USAF

Steaven A. Meyer, BS
Captain, USAF

Matthew L. Ewoldt, BS
Captain, USAF

Edward W. Talley, BS
Second Lieutenant, USAF

March 2005

APPROVED FOR PUBLIC RELEASE; DISTRIBUTION UNLIMITED

AFIT/ENY/GSE/05-M02

A SYSTEMS ARCHITECTURAL MODEL FOR MAN-PACKABLE/OPERABLE
INTELLIGENCE, SURVEILLANCE, AND RECONNAISSANCE
MINI/MICRO AERIAL VEHICLES

Cory A. Cooper, BS
Captain, USAF

Matthew L. Ewoldt, BS
Captain, USAF

Steaven A. Meyer, BS
Captain, USAF

Edward W. Talley, BS
Second Lieutenant, USAF

Approved:

Maj Joerg D. Walter (Chairman)

9 Mar 05
Date

Lt Col Eric J. Stephen (Member)

9 Mar 05
Date

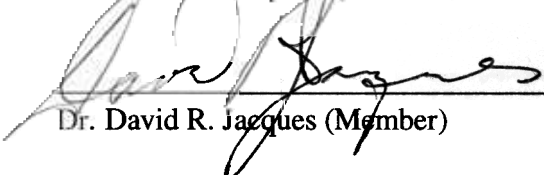
Dr. David R. Jacques (Member)

9 MAR 05
Date

Abstract

With the increase of both technology push and operational pull of Mini/Micro Aerial Vehicles (MAVs) within DoD organizations, an understanding of their interactions and capabilities is necessary. Many MAVs have been developed for specific usage and much speculation made on future uses. Despite their growth there is currently no overarching systems architecture to envelop and guide the DoD's MAV development efforts. The goal of this thesis is to apply sound systems engineering principals to develop a MAV architectural model describing their use in three separate but closely related mission areas: Over-the-Hill-Reconnaissance, Battle Damage Information (BDI), and Local Area Defense. This thesis focuses on single man-packable/operable MAVs utilized by small ground units synonymous with special operations forces (SOF). The three mission areas are combined to define a single overarching Intelligence, Surveillance, and Reconnaissance (ISR) MAV architecture. The architecture focuses on the current state of ISR MAVs and baselines that AS-IS capability. From this architecture, areas of interest relating to MAVs and their use in the DoD are discussed, focusing on enhancing both current and future capabilities of the MAV.

Table of Contents

	Page
Abstract	iv
List of Figures	viii
List of Tables	xii
I. Introduction	1-1
1.1 Thesis Goal	1-2
1.2 Scope and Assumptions	1-2
II. Background	2-1
2.1 The User: Special Operations Forces	2-1
2.1.1 User Background and Operating Environment	2-1
2.1.2 SOF Mission and Core Tasks	2-3
2.1.3 SOF Capability Deficiencies	2-6
2.2 Mission Areas	2-7
2.3 Unmanned Aerial Vehicle	2-8
2.4 Mini and Micro Aerial Vehicles	2-11
2.4.1 Characteristics	2-11
2.4.2 Systems Perspective	2-13
2.5 Systems Engineering and Architectures	2-16
2.5.1 Systems Engineering Overview	2-16
2.5.2 Architectures Overview	2-19
2.5.3 SE and Architecture Policy	2-21
III. Methodology	3-1
3.1 Providing Traceability	3-1
3.2 Architectural Views	3-3
3.2.1 DoD Architecture Framework	3-4
3.2.2 Modeling Languages	3-6
3.2.3 Architectural Products	3-8

	Page
IV. Results	4-1
4.1 Operational Scenarios	4-1
4.1.1 Over-the-Hill Reconnaissance	4-2
4.1.2 Battle Damage Information	4-3
4.1.3 Local Area Defense	4-3
4.2 MAV Traceability	4-4
4.3 Current ISR MAV Architecture	4-9
4.3.1 AV-1 Overview and Summary Information	4-9
4.3.2 AV-2 Integrated Dictionaries	4-12
4.3.3 OV-1 High-Level Operational Concept	4-12
4.3.4 OV-2 Operational Node Connectivity	4-14
4.3.5 OV-3 Operational Information Exchange Matrix	4-18
4.3.6 OV-4 Organization Relationships Chart	4-19
4.3.7 OV-5 Operational Activity Model	4-20
4.3.8 OV-6C Operational Event Trace Description	4-23
4.3.9 OV-7 Logical Data Model	4-25
4.3.10 SV-1 Systems Interface Description	4-26
4.3.11 SV-4 Systems Functionality Description	4-30
4.3.12 SV-5 Operational Activity to Systems Function Traceability Matrix	4-33
4.3.13 SV-6 Systems Data Exchange Matrix	4-35
4.4 DOTMLPF Considerations	4-36
4.4.1 Doctrine	4-36
4.4.2 Organization	4-36
4.4.3 Training	4-37
4.4.4 Leadership and Education	4-38
4.4.5 Personnel	4-38
4.4.6 Facilities	4-39
4.5 Future Capabilities and Technologies	4-39
4.5.1 Future Capability Discussion	4-39
4.5.2 Future Technology Discussion	4-47
V. Conclusions and Recommendations	5-1
5.1 Conclusions	5-1
5.2 Remarks	5-2
5.3 Recommendations	5-3
5.4 Future Areas of Study	5-3

	Page
Appendix A. MAV List of Acronyms	A-1
Appendix B. MAV Traceability	B-1
Appendix C. MAV AV-1	C-1
Appendix D. MAV OV-1	D-1
Appendix E. MAV OV-2	E-1
Appendix F. MAV OV-3	F-1
Appendix G. MAV OV-4	G-1
Appendix H. MAV OV-5	H-1
Appendix I. MAV OV-6c	I-1
Appendix J. MAV OV-7	J-1
Appendix K. MAV SV-1	K-1
Appendix L. MAV SV-4	L-1
Appendix M. MAV SV-5	M-1
Appendix N. MAV SV-6	N-1
Bibliography	BIB-1

List of Figures

Figure		Page
2.1	BQM-34A FIREBEE	2-9
2.2	QH-50 DASH	2-10
2.3	RQ-2A Pioneer Unmanned Aerial Vehicle	2-11
2.4	The MAV compared to existing flight vehicles extracted from [32:3]	2-13
2.5	Example of a MAV	2-14
2.6	A Typical MAV System	2-15
2.7	MAV Hardware Integration [32:7]	2-16
2.8	Systems Engineering Process	2-19
2.9	DoDAF Views and their Integration [24:2-1]	2-20
2.10	DoD Aquisition Process [13:3]	2-22
3.1	Fundamental Linkages Between Views	3-6
3.2	AV-1 - Template	3-9
3.3	OV-1 - Example	3-10
3.4	OV-2 - Template	3-11
3.5	OV-3 - Template	3-12
3.6	OV-4 - Template	3-13
3.7	OV-5 - Template	3-13
3.8	ICOM Notation	3-14
3.9	OV-6c - IDEF3 Example	3-15
3.10	OV-7 - Template	3-16
3.11	SV-1a - Internodal Template Showing Node Interfaces	3-17
3.12	SV-1b - Internodal Template Showing System Interfaces	3-18
3.13	SV-1c - Intranodal Template	3-18
3.14	SV-1d - Intrasystem Example	3-19
3.15	SV-4 - Template (Data Flow Diagram)	3-19
3.16	SV-5 - Template	3-20
4.1	UAV Specification Comparison	4-5

Figure		Page
4.2	Mission/Scenario to Air Force Task Traceability	4-7
4.3	OV-1 for the OTHISR and BDI Scenario	4-12
4.4	OV-1 for the LAD Scenario	4-13
4.5	OV-2 for the Over-the-Hill Reconnaissance Scenario	4-14
4.6	OV-2 for the Battle Damage Information Scenario	4-16
4.7	OV-2 for the Local Area Defense Scenario	4-17
4.8	Consolidated OV-2 (reflecting all scenarios)	4-18
4.9	OV-4 Organizational Relationships Chart	4-19
4.10	OV-5 External Systems Diagram	4-21
4.11	OV-5 Context Diagram	4-22
4.12	OV-5 Level A0	4-23
4.13	OV-6c Operational Event Trace Description	4-24
4.14	OV-7 Logical Data Model	4-25
4.15	SV-1b System-System Interfaces	4-27
4.16	SV-1c Intranodal Version of the <i>Friendly Ground Unit</i>	4-28
4.17	SV-1c Intranodal Version of the MAV	4-29
4.18	SV-4 Functional Decomposition	4-31
4.19	SV-4, 0-Level Diagram	4-32
4.20	SV-5 page 1	4-33
4.21	SV-5 page 2	4-34
4.22	Future Mission Capability Timeline	4-40
4.23	Future MAV Technology Technologies	4-48
4.24	Other Possible Future MAV Technologies	4-50
B.1	Top Level Traceability Diagram	B-1
D.1	OV-1 for the OTHISR and BDI Scenario	D-4
D.2	OV-1 for the LAD Scenario	D-5
E.1	Consolidated OV-2	E-5
F.1	OV-3 Operational Information Exchange Matrix 1	F-5
F.2	OV-3 Operational Information Exchange Matrix 2	F-6

Figure		Page
F.3	OV-3 Operational Information Exchange Matrix 3	F-7
F.4	OV-3 Operational Information Exchange Matrix 4	F-8
F.5	OV-3 Operational Information Exchange Matrix 5	F-9
G.1	OV-4 Organizational Relationships Diagram	G-10
H.1	OV-5 External System Diagram	H-7
H.2	OV-5 Context Diagram	H-8
H.3	OV-5 Initial Decomposition	H-9
H.4	OV-5 Provide Information Processing	H-10
H.5	OV-5 Enable Launch MAV	H-11
H.6	OV-5 Provide ISR MAV Platform	H-12
H.7	OV-5 Enable Land/Recover MAV	H-13
I.1	OV-6c Operational Event-Trace Description	I-8
J.1	Logical Data Model (OV-7)	J-3
K.1	SV-1b Systems Interface Description: Internodal Version showing System-System Interfaces	K-19
K.2	SV-1c Systems Interface Description: Intranodal Version of the <i>Friendly Ground Unit</i> showing System-System Interfaces and System Functions	K-20
K.3	SV-1c Systems Interface Description: Intranodal Version of the MAV showing System-System Interfaces and System Functions	K-21
L.1	Functional Decomposition	L-14
L.2	SV-4 Context Diagram	L-15
L.3	SV-4 Level 0 Diagram	L-16
L.4	SV-4 Level 1 Diagram	L-17
L.5	SV-4 Level 1-1 Diagram	L-18
L.6	SV-4 Level 1-2 Diagram	L-19
L.7	SV-4 Level 1-3 Diagram	L-20
L.8	SV-4 Level 1-4 Diagram	L-21
L.9	SV-4 Level 1-5 Diagram	L-22

Figure		Page
L.10	SV-4 Level 2 Diagram	L-23
L.11	SV-4 Level 2-1 Diagram	L-24
L.12	SV-4 Level 2-2 Diagram	L-25
L.13	SV-4 Level 2-3 Diagram	L-26
M.1	SV-5 Operational Activity to System Functions Traceability Matrix 1	M-7
M.2	SV-5 Operational Activity to System Functions Traceability Matrix 2	M-8
N.1	SV-6 Systems Data Exchange Matrix 1	N-5
N.2	SV-6 Systems Data Exchange Matrix 2	N-6
N.3	SV-6 Systems Data Exchange Matrix 3	N-7
N.4	SV-6 Systems Data Exchange Matrix 4	N-8
N.5	SV-6 Systems Data Exchange Matrix 5	N-9
N.6	SV-6 Systems Data Exchange Matrix 6	N-10
N.7	SV-6 Systems Data Exchange Matrix 7	N-11

List of Tables

Table		Page
2.1	SOF Capability Deficiencies listed by domain	2-6
2.2	Sample Characteristics of Mini and Micro-UAVs [18:210]	2-12
3.1	JCIDS Required Products	3-8
4.1	AFTL Measures [40:103-104]	4-8
4.2	Architecture Purposes	4-11
A.1	List of Acronyms	A-1
C.1	Architecture Purposes	C-3
D.1	OV-1; AV-2 Integrated Dictionary	D-1
E.1	OV-2; AV-2 Integrated Dictionary	E-1
G.1	OV-4; AV-2 Integrated Dictionary	G-1
H.1	OV-5; Functional Entities Integrated Dictionary	H-1
H.2	OV-5; Activity Diagram ICOMs Integrated Dictionary	H-3
I.1	OV-6c; AV-2 Integrated Dictionary	I-1
J.1	OV-7; AV-2 Integrated Dictionary	J-1
K.1	SV-1; AV-2 Integrated Dictionary	K-1
L.1	SV-4; AV-2 Integrated Dictionary	L-1
M.1	SV-5; AV-2 Integrated Dictionary	M-1

A SYSTEMS ARCHITECTURAL MODEL FOR MAN-PACKABLE/OPERABLE
INTELLIGENCE, SURVEILLANCE, AND RECONNAISSANCE
MINI/MICRO AERIAL VEHICLES

I. Introduction

Researching the topic of mini and micro aerial vehicles (MAVs) reveals extensive examples of their application and use already existing in many organizations including: the Department of Defense (DoD), research organizations, academic institutions, and private industry. While the basic MAV concept has been around as long as model airplanes, a major push for their gainful employment in military operations occurred within the last two decades. For reasons of troop security, stealth, hazardous terrain, mundane missions, and vantage point, MAVs have and continue to prove themselves useful. Many organizations have developed and continue to develop MAVs specific to their set of requirements or emerging technologies. However, only a handful were created with the concept of integration in mind, and those that have rarely integrate beyond their specific organization.

While interest in MAVs continues to grow, so has the desire by military planners to seamlessly incorporate these systems into Air Force missions where their utility can be fully realized. Due to the complexity of integrating individual MAV systems into their the currently fielded family of systems (FoS), military leaders and system developers require better methods for defining MAV specifications and how they interact with their environment. These issues are addressed by the Air Force's increased emphasis on systems engineering (SE) and transformation to integrated architectures through use of the DoD Architecture Framework (DoDAF). While the concept of SE is not new, better methodologies were needed within the Air Force to manage complex programs as evidenced when Secretary of the Air Force Roche stated "Many of our current system acquisition

programs are suffering from a lack of attention to or inconsistent application of good systems engineering principles” [30].

This refocus on systems engineering seeks to relate the functional, operational, and systems viewpoints together thus providing both descriptive and visual representations of the system under design. These representations of a system are referred to as architectures. The DoDAF is intended to provide information on how systems are related to higher level architectures; an example of which is the C4ISR (Command, Control, Communications, Computer, Intelligence and Reconnaissance) architecture [9]. The use of sound systems engineering principles and the development of architectures enables a more comprehensive and effective development strategy for the design of systems. An integrated architecture allows the developers and users of a system to better plan for a system’s requirements. If a strategic plan for the use of MAVs, as well as the planning and acquisition of future MAV capabilities is to be built, the entire system must be defined using systems engineering.

1.1 Thesis Goal

The goal of this thesis is to apply sound systems engineering principles to develop an architectural model describing the use of MAVs in three separate, but closely related, mission areas: Over-the-Hill-Reconnaissance, Battle Damage Information (BDI), and Local Area Defense. These mission areas are examined and architectures created to describe current and future MAV capabilities. From these architectures, areas of interest relating to MAVs and their use in the Air Force are discussed, focusing on enhancing both current and future capabilities of those MAVs falling within the scope of this thesis.

1.2 Scope and Assumptions

In defining the scope and assumptions for this thesis, it became evident that the mission areas previously mentioned define, to a certain level, the application of MAVs for this thesis. Before discussing MAV applications, it is necessary to define a UAV and

a MAV. As defined by Army Field Manual 34-25-2, Chapter 1 [41], “UAVs are capable of operating without an internal (human) pilot; are tethered by a radio control link; and can be preprogrammed for both flight and payload operations prior to launch.” By this definition, UAV’s cover a multitude of configurations including size, payload, endurance, etc. This thesis concentrates on a tactical version of a UAV known as the Mini/Micro Aerial Vehicle (MAV).

As the name implies, MAVs are certainly smaller in size and in many instances, less capable than their larger counterparts. However, their diminutive dimensions afford faster deployment times, a much smaller logistic footprint in the field, and eventually, the ability to be carried by normal ground forces rather than specialized units. Further scoping the problem, this thesis defines the MAV system to be single-man-packable and single-man-operable. The system also must not require the carrier to sacrifice normal mission essential gear typically carried into the field.

The products and analysis provided with this research are based on MAV systems utilized by small units synonymous with special operations forces (SOF). While the scope focuses on a single-man-packable/operable system, it is understood that the specific user determines how the MAVs are carried into theater. Another point to remember is that the MAV system described in this research is part of a family of intelligence gathering systems available to the unit. As such, the MAV is primarily used for close-in (typically no more than 3km range) tactical reconnaissance where using larger systems such as the Pointer (RQ-2A), proves too difficult or time consuming to employ for the given situation.

II. Background

In order to understand the focus, direction, and results of this thesis, a background discussion of mini/micro aerial vehicles (MAV) and their operators is in order. First, an overview of the user community is presented, followed by a discussion of the selected mission areas. Presented next is a brief overview of unmanned aerial vehicles (UAV) and the sub-category of MAVs. The final topic is the background of systems engineering and the role it plays in this effort.

2.1 The User: Special Operations Forces

The user's background, operating environment, mission tasks, and capability needs and deficiencies are all important variables to understand when designing a system. Ultimately, the user must be satisfied in order for the design to be successful. For this thesis, the primary users are members of the Air Force Special Operations Command (AFSOC) which is the Air Force component of the United States Special Operations Command (USSOCOM). The following sections provide an overview of these four variables (user background, operating environment, mission and core tasks, and capability deficiencies) which tie directly into AFSOC's roles and responsibilities within the special operations community. Due to their similarities the first two variables, user background and operating environment, have been combined into one discussion.

2.1.1 User Background and Operating Environment. Special operations forces (SOF) conduct fast, surgical operations at great distances from established bases by using state-of-the-art communications, aircraft, and specially trained personnel from each branch of service. These forces infiltrate and exit areas that are hostile to the United States, or politically sensitive enough to warrant concealment of a US military presence. In-depth knowledge of the region and its inhabitants can mean the difference between success and failure in the realm of special operations. Typically special operations involve short engagements using *shock and surprise*, or long-term commitments that require patience

and cultural understanding [26:6]. Since their missions or tactics often require covert, concealed, or discreet capabilities, the systems they carry into the field must be robust enough to survive the environment (i.e. small, durable, quiet, etc.) [25:7].

Use of special operations tactics can be traced back throughout human history. They first appeared in the United States during the early colonial period, when officers established specialized units to fight against irregular enemy forces. Until 1986, the United States created and used special operations forces on an ad hoc basis, frequently to the point of exhaustion of the personnel. The units were then disbanded when the crisis was over. The scale and complexity of warfare has grown, thus increasing the time it takes to build a competent special operations force. When the nation needed special operations forces for a sensitive mission, the capability simply did not exist. It took the strategic failure of Operation Eagle Claw, which was a response to Iranian students taking 50 Americans hostage in 1979, to implement the concept of a standing joint capability to conduct special operations. Although this is a historical example geared toward special operations forces personnel, the lesson learned also applies to the equipment they use. Not only do we need to keep these personnel trained for tomorrow's war but also develop and field capabilities to ensure that the war of tomorrow is won effectively. One of the goals of this research is, in fact, to consider future capabilities that MAVs can bring to the field [25:7-8].

MAVs are not widely available, and traditionally special operations forces rely on manned aircraft, reconnaissance teams, and satellites to provide the needed intelligence [26:2]. These manned systems and space assets prove very useful as information providers; however, they are considered high value assets. The term high value asset is used to refer to those assets that are in high demand by units and commanders but have limited numbers. One design goal for MAVs is to provide low cost, highly capable intelligence gathering platforms that take the place of such high value systems.

Why is an architecture for the MAV needed? The answer lies in the fact that proper information management is the key to modern conflicts. Special Operations Forces are often tasked directly by political leaders and monitored at the national level [26:

6]. These operations cross all branches of the armed service community and require detailed planning and rapid coordination. All joint assets (air, ground, maritime, space, etc.) must be able to communicate quickly and efficiently. Such efficiency and timeliness requires responsive command and control networks that interconnect the various services, commands, and government leaders or offices. The architecture detailed in Chapter IV illustrates how the MAV system interacts with its external environment to provide the proper level of communication and control required by battlefield planners.

Given the probability of future attacks, special operations forces continue to incur increasing pressure to avoid failure meaning they must be prepared to wage war “everywhere, all the time” [25:7]. To cope with the complexity of these challenges, leaders of special operation forces need greater capabilities; most notably a greater capability for observing their surroundings and targets in real-time with immediate availability. To achieve this desired capability, the SOF teams require a new surveillance, reconnaissance, and communication asset to deliver near-real-time, full motion video for tactically significant periods of time [26:1]. This need for near-real-time video surveillance is the driving requirement for this research and further demonstrates that an MAV could be a plausible solution. To further expand the MAV solution, other mission and technology capabilities are explored which demonstrate how MAVs can integrate with tomorrow's joint special operations force.

2.1.2 SOF Mission and Core Tasks. System design requires an understanding of the intended operational environment, the mission tasks, background information relevant to the user and the existing capability gaps or needs. If the system does not address these four factors, then the system will not fulfill the users needs. While the previous section outlined the background and general operating environment of the special operations forces, this section focuses on their mission tasks.

The United States Special Operations Command (USSOCOM) plans, directs, and executes special operations in the conduct of the War on Terrorism in order to disrupt,

defeat, and destroy terrorist networks that threaten the United States, its citizens and interest worldwide. USSOCOM organizes, trains, and equips special operations forces provided to Geographic Combatant Commanders, American Ambassadors and their country teams. [25:4] Special operations forces are responsible for nine principal missions or core tasks with additional collateral tasks. Collateral special operations activities apply special operations capabilities in areas beyond the core tasks [26]. These areas include security assistance, humanitarian assistance, peace operations, coalition support, counter-drug operations, personnel recovery, and special activities. The nine core tasks identified by USSOCOM [25] are as follows:

1. Unconventional Warfare (UW)
2. Direct Action (DA)
3. **Special Reconnaissance (SR)**
4. Foreign Internal Defense (FID)
5. **Counter-Terrorism (CT)**
6. Psychological Operations (PSYOP)
7. Civil Affairs Operations (CAO)
8. Information Operations (IO)
9. Counter-Proliferation (CP) of weapons of mass destruction (WMD)

All of these tasks are equally important to the SOF mission; however, this research focuses only on the core tasks of special reconnaissance and counter-terrorism. This allows the current mission tasks to align with current (or *AS-IS*) MAV capabilities. Taking MAV capabilities and demonstrating how they aid special operations forces is shown in Chapter IV.

The special reconnaissance task (also referred to as recon) includes reconnaissance and surveillance actions that collect or verify significant information complementing or supplementing national or theater intelligence assets [25]. These special reconnaissance

teams are often the *eyes and ears* of unconventional warfare, direct action, counter-terrorism, and foreign internal defense operations [26]. The ability to broadcast imagery over long distances is required in order to increase each team's overall situational awareness. Another need to increase mission effectiveness is the need for low probability-of-intercept communication, which in turn complements the need for long range communications. Based on current technologies as the communication range increases the probability-of-intercept also increases. This applies to the MAVs design trade-offs in a sense that the user and system designer will have to choose either long-range or low probability-of-intercept.

The core task of counter-terrorism requires highly trained personnel that can preempt or resolve terrorist incidents outside the United States. This is one of the high-profile tasks of today's special operations forces [25]. The counter-terrorism task is extremely dependent on intelligence intensive because it involves such activities as finding, isolating, and neutralizing or capturing terrorists. If the intelligence can be made available in a timely manner, then teams of special operations forces will be able to increase the success of missions such as rescuing hostages, attacking the terrorist infrastructure, and recovering sensitive material from a terrorist organization [26].

While not listed as a core task, re-supplying special operations forces in the field is implied with certain tasks, such as special reconnaissance. This is often a challenging process because special operations forces tend to work great distances from base camps, typically behind or in close relation to enemy lines and far from major supply points [26]. In most cases, the teams must traverse difficult terrain or parachute into isolated areas where ground transportation is not feasible or tactically advantageous. Throughout this research, the requirement for resupplying the forces in the field is assumed and the architectural products presented in Chapter IV do not reflect the logistic support aspects required for the MAV system.

2.1.3 *SOF Capability Deficiencies.* The previous sections discussed three of the four design factors for system design: user background, operating environment and mission tasks. This section expounds on the fourth factor capability needs. To meet the numerous tasks facing special operations forces and to ensure that they have the appropriate equipment and resources, Congress authorized USSOCOM its own head-of-agency authority, program authority and budget for research, development, and acquisition of special operations unique material and equipment [26]. Using a modernization process, the USSOCOM begins with a strategy review to determine where the capabilities and attributes can be incorporated into various joint strategy documents. The process follows an approach of strategy-to-task, task-to-need, need-to-concept, concept-to-technology, and technology-to-execution [26]. This modernization process results in the identification of several capability deficiencies which are broken into three domains: command-control-communications (C³), intelligence, and resupply. This provides designers with a broad idea of user requirements. Table 2.1 lists the capability deficiencies, extracted from Maj Stephen Howard's Special Operations Forces and Unmanned Aerial Vehicles [26], that were relevant to this study and MAVs.

Table 2.1 SOF Capability Deficiencies listed by domain

<i>Domain</i>	<i>Capability Deficiencies</i>
Command, Control, and Communications	Potential for enemy to monitor or destroy our information systems.
Intelligence	<ul style="list-style-type: none"> - No real/near-time imagery from national systems - No real-time interface between aircraft, planners, and intel systems - No-real-time imagery for target study - No all-source threat location data - Enhanced target identification and marking capability required
Resupply	Need resupply of expendables (batteries, food, water, medical, ammo)

2.2 *Mission Areas*

The three intelligence, surveillance and reconnaissance (ISR) missions for this thesis are Over-the-hill Reconnaissance, Battle Damage Information, and Local Area Defense. A mission area is simply a more defined or scoped task that relates to one or more of the core tasks, thus making mission areas a subset of core tasks. Recall that this thesis focuses on the special reconnaissance and combating terrorism core tasks. The following discussion scopes these mission areas as they relate to the core tasks.

Over-the-hill reconnaissance enhances a SOF teams situational awareness by extending their beyond line-of-sight ISR capabilities. This mission area got its name from the idea that a user could deploy a miniature unmanned system to peer over a hill or to get a birds eye view of complex terrain in order to assess suspected enemy positions. There are many systems that possess this capability; however, many are high value assets and others are simply not available due to mission sensitivity or execution area. What SOF teams require is the capability to observe the enemy and their surroundings regardless of obstacles.

Battle Damage Information collects information on the damage inflicted upon the enemy following an offensive strike. Battle Damage Information (BDI) is similar to Battle Damage Assessment (BDA), but lacks the ability and/or authority to properly assess and make a decision based on intelligence gathered. BDA, on the other hand, implies that the information has or is being transformed into actionable intelligence for further use by forces. In order to gather the needed intelligence, commanders need access to reconnaissance platforms. If access is not possible, it may take a significant amount of time in order to get the information needed for the assessment. Special operations forces, or other units already in the field, have the potential to provide time sensitive intelligence information if equipped with MAV systems. The MAV can deploy from a nearby unit to gather the intelligence needed and route this information to personnel qualified to conduct the assessment.

Local Area Defense (LAD) covers any scenario in which SOF or other friendly forces are defending against an enemy attack or preventing insurgents from entering an area. This mission area requires rapid response from the defenders if they wish to succeed. In this case, the MAV can easily serve as a rapidly deployable sensor platform to gather the needed information.

Though these mission areas are different in execution, they are very similar when considering the required information exchanges and materiel requirements. As such, the remainder of this thesis centers on a consolidated view of the mission areas; expounding on the individual mission areas only when required.

2.3 *Unmanned Aerial Vehicle*

The previous two sections focused on the special operations forces background and the intended mission areas for MAVs. It was also mentioned that MAVs are a subset of the larger category of Unmanned Aerial Vehicles (UAVs). This section provides a background of UAV classification and history of their development and usage in the modern military.

By definition, any aircraft not carrying a pilot can be considered a UAV. Due to this broad definition, several classifications exist to further delineate UAVs of different design and capability. The first of these is a remotely piloted vehicle (RPV). RPVs are those unmanned platforms requiring full control by a ground station or separate manned aircraft. These systems are exemplified by off-the-self remote control aircraft found in hobby shops. The second category, known as drones, are a self-controlling platform that are preprogrammed prior to launch and cannot accept mission changes once dispatched [20]. The last category of UAVs is capable of self-navigation, in-flight reprogramming and can perform autonomous take-off and landing if equipped to do so. Though they do not have a special descriptor to separate them from RPVs and drones, the remainder of this thesis assumes the term UAV abides by the latter definition.

The use of UAVs dates back to 1887 when Englishman Douglas Archibald attempted to tackle the problem of *over-the-hill* observation by attaching a camera to a

kite and then flying the platform high enough to observe the enemy [44]. Other examples of early UAVs include the use of explosive laden balloons during the Civil War, by both Union and Confederate soldiers and during World War Two by the Japanese. The United States, also during WWII, attempted to use operational aircraft in an unmanned fashion by flying the aircraft to a specified altitude and then bailing out, allowing the explosive-laden aircraft to continue to their targets [19].

The war in Vietnam saw the productive use of drones in the area of intelligence. Ryan BQM-34 Firebee (Figure 2.1) UAVs were used over North Vietnam for day and night missions using payloads primarily composed of conventional cameras or signals



Figure 2.1 BQM-34A FIREBEE

intelligence equipment [19]. Ultimately, Firebees flew more than 3,400 sorties in support of American objectives. The QH-50 DASH (Figure 2.2) remotely piloted helicopter (RPH) was also used by Marines for beach reconnaissance and spotting in Vietnam [43] but the technology required for this system was not mature enough for the program to continue.

Although these examples have proven the potential for UAVs to perform reconnaissance and, in some cases, strike missions, many countries avoided UAV development due to extensive costs and bulky sensor packaging [20]. In fact, it was more common to find a UAV serving as a decoy providing anti-aircraft practice for naval gunner's or guiding munitions to their targets, such as the German V-Series rockets during WWII, than it was to find them performing reconnaissance missions [16]. After the mid-



Figure 2.2 Gyrodyne QH-50C DASH [36]

1960's, the size and cost of the electronics began to rapidly decrease; however, this did not create a significant change in interest levels for UAVs.

General interest in UAVs had a noteworthy increase after the Israeli military used them against the Syrian air defense system in the Bekaa Valley in 1982 for reconnaissance, jamming, and as decoys [16]. Despite the numerous problems encountered by UAV systems, the Israelis proved that UAVs could perform valuable combat service in an operational environment. Countries around the world began to ramp up their UAV programs by designing systems to perform dangerous and dull missions typically handled by manned aircraft [20].

During Operation Desert Storm, the Navy and Marines operated RQ-2A Pioneer (Figure 2.3) UAV systems to provide target identification enabling the engagement of Iraqi defense forces on Faylaka island [19].

More recently, UAVs have been employed to combat terrorism in both Afghanistan and Iraq. Predator UAVs have been on the cutting edge of experimentation as this platform, primarily designed for intelligence gathering, has also been modified to provide



Figure 2.3 RQ-2A Pioneer UAV [36]

an offensive capability. While UAVs experience more interest and funding, they are typically built to fill a specific military need and are classified based on their capabilities.

UAV classifications vary depending on military service branches, authors, and manufactures. Some of the more common classifications are: tactical and endurance; lethal and non-lethal; very low cost close range, close range, short range, and medium range; expendable and recoverable. The users' needs and operating conditions typically drive which type of UAV is best. In the case of over-the-hill reconnaissance, UAVs are classified as tactical (short range, field supported), non-lethal, very low cost close range, and expendable (with the option to recover).

2.4 *Mini and Micro Aerial Vehicles*

While both mini and micro-UAVs (MAVs) are a subset of UAVs, MAVs are unique due to their smaller size. This section introduces some of the unique characteristics MAVs possess and provides a systems perspective for a typical MAV system. From this section onward, the term MAV refers to both mini and micro-UAVs.

2.4.1 Characteristics. An MAVs small size brings about many unique operational, logistic, and acquisition characteristics. Operationally, MAVs can provide capabilities to smaller units that heretofore were unachievable because UAV systems were

simply too expensive and complex to be utilized by small military units. Additionally, these systems were unable to provide *time-critical* information for the units that would most benefit from their use in the field. MAVs can also have a variety of payloads that can be manufactured for a single airframe which enables the concept of reusability by interchanging payloads in the field. Logistically speaking, MAVs can be designed to have a relatively small footprint. As for the acquisition side of the house, MAVs present a *faster, better, cheaper* approach to their development, procurement, and fielding [27]. These characteristics are very beneficial, but with every benefit there are challenges.

The main challenges with MAVs are their limited payload weight, aerodynamics, systems integration, and mission utility. The point here is to recognize, as with every system, that there are design challenges that need to be considered. To place some significance and to give the reader a better idea of the term *small size*, the following table better characterizes a MAVs operational scale. The characteristics shown in Table 2.2 are averages. A particular mini-UAV or micro-UAV may have values smaller or larger than the ones presented in the table.

Table 2.2 Sample Characteristics of Mini and Micro-UAVs [18:210]

<i>Characteristic</i>	<i>Mini-UAV</i>	<i>Micro-UAV</i>
Weight (g)	4540	49
Wingspan (cm)	121	15
Aspect Ratio	7	3
Wing Area (cm ²)	2096	76
CL (Aerodynamic Lift Coefficient)	0.6	0.6
CL/CD (Aerodynamic Lift/Drag Coefficient)	26	5
Propeller Efficiency	0.8	0.5
Electrical Efficiency	0.6	0.6
Average Power (W)	178	5.1
Average Power/Wing Area (W/cm ²)	0.085	0.068

A general picture of how MAVs stack up to other aircraft based on size is provided in Figure 2.4. This figure provides a point of reference for mini and micro-UAVs, and attempts to further define mini-UAVs as fitting somewhere in between micro-UAVs and small wingspan UAVs.



Figure 2.4 The MAV compared to existing flight vehicles extracted from [32:3]

2.4.2 *Systems Perspective.* A typical MAV system is composed of an air vehicle, ground control or base station, payload, and data link [16]. Many UAV systems also include support subsystems designed to aid in launch and recovery, ground handling, and system maintenance. Due to the MAVs size and weight, these support subsystems will not be as complex and, in some cases, not required at all. The launching and recovery of a MAV does not require a system but an operator initiated event (on/off switch, hand launch, etc.). Although these subsystems or events are important to a MAVs operation, only the air vehicle, ground control or base station, payload and data link systems are discussed further.

The air vehicle, as shown in Figure 2.5 is the airborne piece of the system that includes the airframe, propulsion unit, flight controls, power source, and communications equipment. The electric motor serves as the propulsion unit in most MAVs but combustion engines are also a viable alternative. Power sources are typically either batteries or combustible fuel. Current MAV navigation encompasses a broad range of systems to include an on-board autopilot, inertial navigation system (INS), global positioning systems

(GPS), and memory to store mission related data (waypoints). Onboard communications equipment in most MAVs usually consists of an antenna, transmitter, receiver, and the supporting hardware and software.



Figure 2.5 Example of a MAV

The ground control or base station plays an important role in today's reconnaissance based MAVs because they represent the operational control center for the MAV system. The ground station typically manages video, command and control functions, and the processing of telemetry data received from the air vehicle [16]. Key systems that need to be present include control and display consoles, video and telemetry instrumentation, signal processing, data terminals, and communications equipment including antennas.

In most cases, the MAV payload is the most expensive piece of the system. For reconnaissance missions, the payload usually includes video cameras capable of either day or night (infrared) operations. Other possible payloads include: target designation using a laser, radar sensors such as a moving target indicator or synthetic aperture radar, electronic warfare (EW) systems, meteorological sensors, and chemical sensing devices [16]. Due to size, power, and weight restrictions most of the signal processing is left to the base station; however, some limited processing may still occur on the air vehicle depending on the payload. As technology continues toward smaller components and faster processing,

MAV capabilities will continue to grow providing operators critical tools necessary for mission accomplishment.

One of the key subsystems for any MAV is the data link. This link provides bi-directional communication either on demand or on a continuous basis. An up-link provides vital command instructions to the air vehicle. The down-link contains two types of information; one for command acknowledgment and status information, and the other for sensor data such as radar or video feedback [16]. Figure 2.6 helps to illustrate MAV systems by providing an example of a typical system broken into key subsystems and then showing how these subsystems are tied together. As new technologies and capabilities

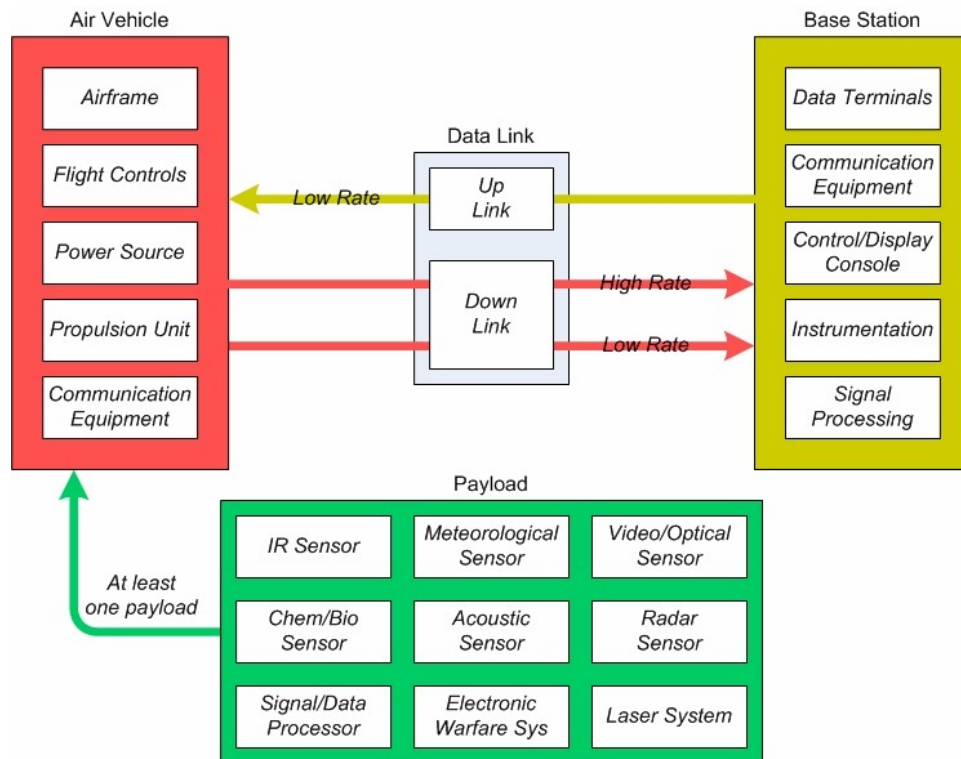

Figure 2.6 A Typical MAV System

are explored, new systems and/or subsystems are needed, particularly in the area of the various payloads.

From this level, systems integration is straightforward; however, the actual physical integration of hardware and software presents one of the greatest challenges in MAV

design. As vehicle size decreases or functionality increases, the integration becomes more complex [32:7]. Similar to Figure 2.6, Figure 2.7 focuses more on the general physical hardware integration of a MAV. This MAV system concept helps guide the system architecture products and future capabilities presented later on.

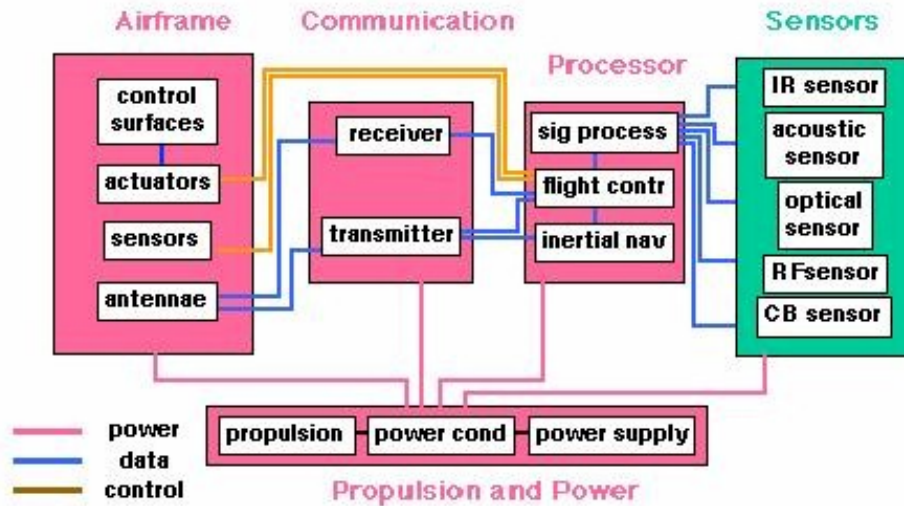

Figure 2.7 MAV Hardware Integration [32:7]

2.5 Systems Engineering and Architectures

Designing a system such as a MAV to meet the current and future requirements of its users in a system of systems (SoS) and family of systems (FoS) environment is a complex problem. Missions and operating environments may change and systems that interface with the MAV may change. The ability to continue to utilize an existing MAV system in constantly changing and unique environments while providing a desired capability is a problem that sits above the component design level. That is why the use of a systems approach to this problem is needed. The use of architectural views to describe a MAV system should facilitate its development.

2.5.1 Systems Engineering Overview. Systems engineering, as a discipline, is defined in many ways. The International Council on Systems Engineering (INCOSE)

defines it as “an interdisciplinary approach and means to enable the realization of successful systems. It focuses on defining customer needs and required functionality early in the development cycle, documenting requirements, then proceeding with design synthesis and system validation while considering the complete problem” [7]. More simply put, “Systems Engineering is the design, production, and maintenance of trustworthy systems within cost and time constraints” [37].

It can be argued that systems engineering, in some form, has been around since many of the ancient wonders of the world were built. It is difficult to imagine immense structures such as the Pyramid of Khufu in Egypt, the Temple of Artemis at Ephesus, or the Hanging Gardens of Babylon were designed and constructed without “an interdisciplinary approach and means to enable the realization of *these* successful systems” [7].

The presence of a systems engineering focus was also evident at other times throughout history whenever a large and/or complex system was designed and constructed. Examples include the Roman aqueducts, the Great Wall of China, European castles and cathedrals, and centuries of ship building. As one will notice, prior to the industrial and technological revolutions, most large and complex system design efforts were civil engineering or classically *architectural* structures. Architects were, in a way, the first systems engineers. “Indeed, the Greek word *architecton* means master builder or master mason. The term describes one who designs and builds structures whose form and function is both appealing and useful. ...The architect has the special role of eliciting and converting the needs and desires of the customer that commissions him into a design that will be especially satisfying to that customer” [31:227]. This is why the discipline of systems engineering so closely relates its processes and tools to those of an architect.

The Industrial Revolution brought about a major thrust to design and enable machines to perform tasks that previously only humans performed. The design of these machines and tools was initially understandable and straightforward. Many of the systems were relatively small and the tool-users themselves were likely a part of the design process. There also existed, in many cases, a trial and error approach to the system design in

absence of more formally defined systems engineering processes [37:6]. As the machines and tools became more and more complex, single tool-users could no longer design the system. Teams of designers and technically specialized individuals were now necessary. With a new host of subsystem and component specialists working on complex systems, there developed a need to integrate and organize the design process in a more efficient manner.

Following the end of World War II, the boom of the technological age began to take off both figuratively and literally. The push of opposing nationalities to develop longer-range missiles, better aircraft, and nuclear capabilities placed large amounts of competitive pressure on fast and effective design processes. The countries and development teams with more efficient and productive design processes gained national and military leverage [29:6]. This pressure to design and deploy systems to meet the users need continued throughout the past few decades, both in the military and commercial sectors. The role of the systems engineer could be viewed as the integrator between all of the other disciplines necessary to design the system. Standardized languages and system representation techniques were developed and used to enable all of the key players of a system to see their own role in the complete system.

The advent of the information age, through the use of computers and software, presented a new host of challenges for the systems engineering discipline. In the largely abstract environment of software development, there now exists the need to have effective and efficient processes in place that integrate all aspects of the software development. Developers of different parts of an overall software package need some way of conceptualizing the end result. That end result, and the satisfaction of the users' requirements, were more important than the sum of all the individual system pieces. New and tailored ways of viewing and communicating the system to other key players and being able to aggregate the subsystems into a whole, were now the focus of systems engineers. This focus, and the systems themselves, are many times too complex to visualize in simple terms. The

The term architecture is defined by IEEE Std 1471-2000 as “the fundamental organization of a system embodied in its components, their relationships to each other, and to the environment, and the principles guiding its design and evolution” [28:3].

Three fundamental views create an architecture description: the operational view (OV), systems view (SV), and technical standards view (TV). Although the fourth view, the all-view (AV), provides information pertinent to the entire architecture, it does not represent any of the aforementioned architectural views. As seen in Figure 2.9, each view plays a special role in describing the system. The operational view identifies what needs to be accomplished and who does it. The systems view relates systems and characteristics to operational needs. The technical standards view prescribes standards and conventions used to develop the system. As can also be seen in Figure 2.9, each view provides elements to the other views that allow the resulting architecture to be integrated [24:2-1]. These views and their components are covered in more detail in Chapter III.

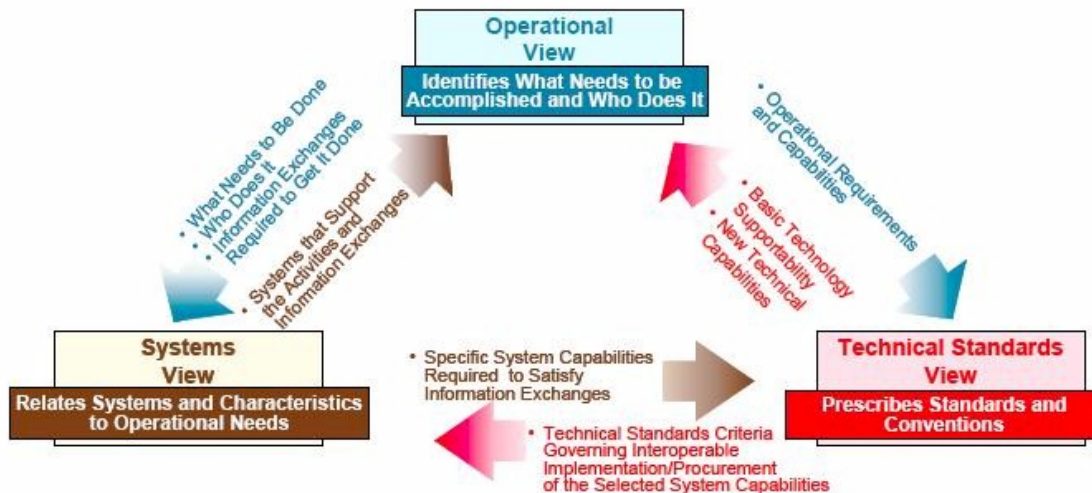

Figure 2.9 DoDAF Views and their Integration [24:2-1]

While architectures are of evident value to the systems engineer, they also play a vital role in communicating with the key operators/users of a system. Without many of the architecture products, key users may have difficulty understanding aspects of the integrated system. The architecture provides the necessary documentation of the systems

operating environment, requirements, functions, subsystems, inputs, outputs, etc. The documentation also provides the traceability necessary to enable the realization of the entire system.

2.5.3 SE and Architecture Policy. Beyond the practical benefits of architectures, they are also now required by law and high-level policy for acquisition programs within US government agencies. The Clinger-Cohen Act of 1996 requires all executive-level departments to use architectures to develop, maintain and facilitate integrated IT. In the DoD, it also requires architectures for National Security Systems (NSS). A NSS is any telecommunication or information system operated by the US Government, in which the function, operation, or use involves intelligence activities. The activities can be cryptologic activities related to National Security or the command and control of military forces. Activities may also require the use of equipment that is an integral part of a weapon or weapons system, or be critical to direct fulfillment of military or intelligence missions [1]. This description of a NSS relates directly to the role and missions of MAVs. The mission areas for MAVs this research develops deal directly with information systems that involve intelligence activities. The information that they collect can also influence the command and control of military forces and be an integral part of the employment of weapon systems. Therefore the Clinger-Cohen Act requires an architecture for MAVs.

In response to this act, executive-level departments and agencies also updated and changed many high-level policies to include Office of Management and Budget (OMB) Circulars A-130 and A-11. These circulars directed that all federal organizations have formal frameworks for developing architectures and demonstrate how their capital planning and budgeting link to, and support, those architectures [2] [35].

Within the DoD, the Chairman of the Joint Chiefs of Staff provided instruction through CJCSI 3170.01, “Joint Capabilities Integration and Development System (JCIDS)” to require integrated architectures as a formal part of the DoD acquisition system [3]. The Initial Capabilities Document (ICD), Capability Development Document (CDD),

and Capability Production Document (CPD) each support key decision milestones in the process. They also all require specific architecture products to support those milestones. Figure 2.10 shows how these documents and milestones are a part of the DoD's acquisition process.

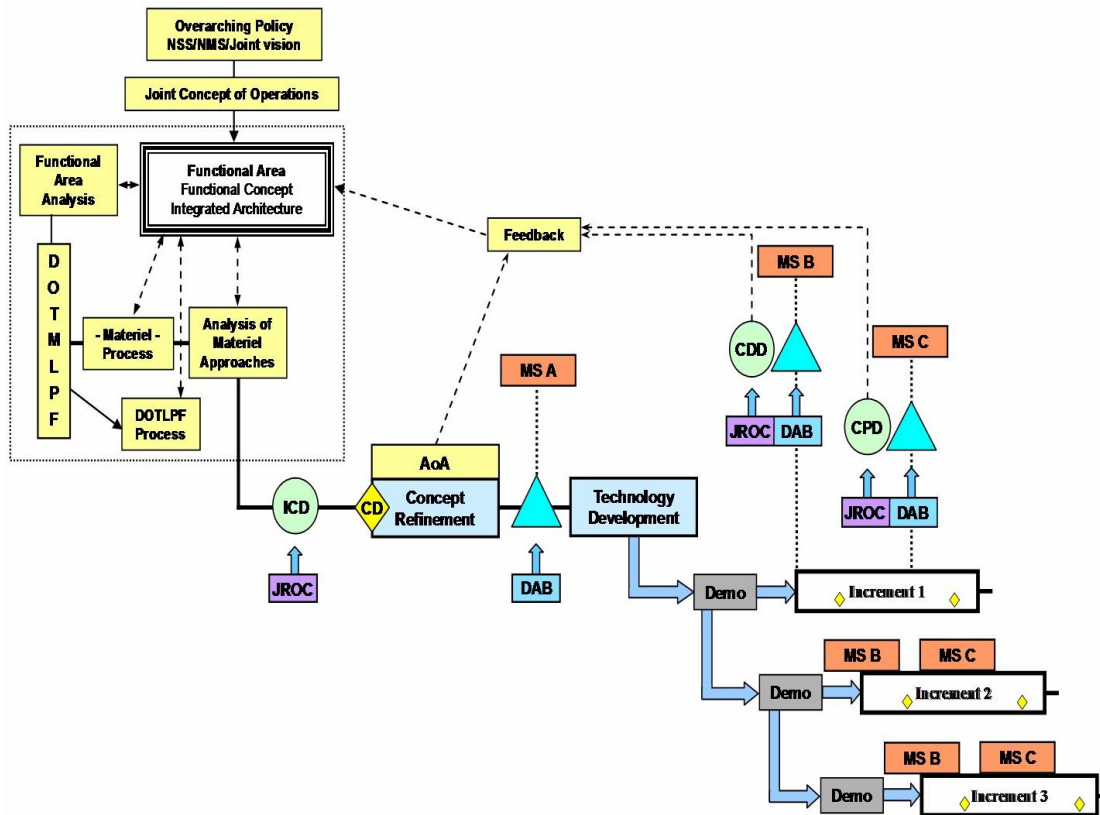

Figure 2.10 DoD Acquisition Process [13:3]

With these major organizational and policy changes in the last decade, architectures are now important not only for the successful development of the actual system, but also for the effective operation of the organizations that develop the system. For these reasons, an integrated architecture is necessary to document, develop and lay the ground work for a successful MAV system. Currently there are no architectures for MAV systems, their current mission areas or future mission areas. In order to efficiently implement MAVs in the DoD, a baseline architecture representing current MAV capabilities is imperative and is the impetus for this thesis.

III. Methodology

The area of systems engineering, its principles and tools have been selected to examine the intelligence, surveillance and reconnaissance (ISR) mini/micro aerial vehicle (MAV). This approach is ideal given the variety of systems that must interact to make the MAV useful in its missions. Systems engineering relies heavily on its architectural products to promote overall system understanding. This chapter discusses the importance of traceability in the Systems Engineering (SE) process, gives an overview of DoD development of architectures and then closes with an in-depth description of all pertinent architectural products. Since the products are numerous and form many perspectives, traceability is vital to keep the architecture understandable and tied back to the original system requirements.

3.1 Providing Traceability

Throughout any effort to produce an integrated architecture, traceability is key. Traceability progresses from the identification of a capability gap to the assignment of system components to perform specific functional tasks.

“Traceability requires the establishment of an unbroken chain of comparisons to stated references” [33]. This reference describes traceability in the way that a crime scene investigator handles evidence in a criminal case. There must be that *unbroken chain* such that a case, or in this thesis a conclusion, can be well-founded and understandable. “Requirements traceability is the ability to describe and follow the life of a requirement, in both a forward and backward direction, i.e. from its origins, through its development and specification, to its subsequent deployment and use, and through periods of ongoing refinement and iteration in any of these phases” [22:94-101]. Not only does traceability tie a system design back to its requirements, but it also allows the designers to step forward and backward through the design while still understanding all of the defined and standardized pieces.

Traceability is a characteristic of an architecture that allows the reader/user to understand the progression of a thought throughout the entire architectural design process. It is the description of understandable links between various views and can be used to assess how the original capability needs are being met by the designed architecture. Without traceability, potential exists to ignore original capability gaps and once the architecture is designed, it may be only a set of detailed views; not an integrated architecture.

The traceability of a capability gap begins the system design process providing the links, during concept exploration and eventually the chosen system design. Once a concept has been selected, the high level measures obtained from the applicable tasks that relate to the capability gap are used to develop lower level measures of effectiveness and performance that will be used to evaluate system requirements. Thus, when looking at the ISR MAV, key parameters are identified that will help determine the level to which ISR MAVs fill the gap. Architectures provide a powerful tool that can be used to help define parameters throughout system design.

In this thesis, traceability efforts started at the top of the DoD capability hierarchy. To facilitate understandable requirements decomposition, two parallel approaches were used to determine where the capability gaps existed. The first approach looked at the organizational mission areas of the using commands. Starting at the national level, each organization's mission statement was reviewed and traced to its sub levels; leading to the primary ISR MAV mission areas. The concurrent approach looked at the Air Force Task List (AFTL) to determine which tasks that the ISR MAV would support through the AFTL hierarchy. Since the ISR MAV missions, described in Chapter IV, describe Air Force focused missions, AFTL tasks were used in lieu of tasks from the Universal Joint Task List (UJTL). However, the AFTL resides at the tactical-level of the UJTL.

Once the operational scenarios were linked to identified capability gaps and missions, the next steps were to review the given scenarios and corresponding AFTL's for a tailored list of measures. These measures represent the characteristics that an accepted

concept must embody as a solution to the capability gap, and that would be necessary to effectively evaluate the system's performance. While the AFTLs provide some top-level measures for comparing different concepts, further refinement must be accomplished in order to provide that would be useful in describing a tactical MAV system. Therefore, several other specific measures were developed for the ISR MAV.

This chain of decomposition from national-level missions to scenarios, to measures now provides traceability to the ultimate system's testable configuration. From the scenarios and measures, an integrated architecture can be produced to facilitate that testable design. The integrated architecture will also aid in developing the necessary system requirements to develop the actual system that will be evaluated by the list of system measures. Throughout the architecture design, traceability plays a key role. Many parts of the architecture must relate to and trace similar objects to other parts of the architecture. The next few sections describe an integrated architecture in detail and traceability is a present and a necessary attribute to validate the final architecture.

3.2 Architectural Views

While traceability describes the connections that should be maintained while describing a system in many different views, an architecture is a way of organizing those views.

“An architecture is the fundamental organization of a system embodied in its components, their relationships to each other, and to the environment, and the principles guiding its design and evolution” [28].

A well understood system depends not only on comprehending the information contained within each view, but also the framework in which the view was created. The system designer and user of the various architectural views benefit from first understanding what a specific architectural view is designed to present and how the specific system should be instantiated from that view. Then both parties can read the information together and also understand the context in which the system has been placed.

An architecture can only be defined as integrated when its products and their components are developed such that the components defined in one view are the same (same names, definitions, and values) as those referenced in another view [24:1-1]. In terms of the three architectural views, an integrated architecture refers to an architecture description that has integrated the operational, system, and technical standards views. With a properly integrated architecture, complex systems are better understood by the users, engineers, designers, maintainers, etc. This increased understanding ensures that the system properly integrates with other systems or external systems (external systems are those systems that are outside of the design boundary but are needed in order for the designed system to function properly).

3.2.1 DoD Architecture Framework. As with many major written products, guidelines or style guides exist to frame the architecture. Several sets of guidelines are available detailing how to *architect* a system. In the 1950's, the Structured Analysis and Design Technique (SADT) was created. A combination of several separate but related techniques; it was a process-focused approach and works very well with the design of physical systems. The SADT was used initially in the formation of a Command, Control, Communications, Computers, Intelligence, Surveillance, and Reconnaissance (C4ISR) architecture framework by and for the development of C4ISR systems in 1997.

Through the past few decades, a different architecting construct also emerged from the software development community. The Object-Oriented (OO) method, which viewed systems in more of a data-centered approach, showed that it was very useful with the growing use of software-dependent systems within the DoD. In an effort to correlate both the SADT and OO approaches, [8] a DoD working group built upon the C4ISR Architecture Framework to form a DoD-wide standard for architecture development. It is called the DoD Architecture Framework 1.0 (DoDAF). It gives descriptions, examples, and templates from both the SADT and OO approaches in producing the necessary products for an integrated architecture. For this thesis, DoDAF was used as the guiding

instruction for producing architectural views. DoDAF gives the following description of architectures.

An architecture description is a representation of a defined domain, as of a current or future point in time, in terms of its constituent parts, what those parts do, how the parts relate to each other and to the environment, and the rules and constraints governing them. Within the DoDAF, architectures are described in terms of three views: Operational View (OV), Systems View (SV), and Technical Standards View (TV). An architecture description is composed of architecture products that are interrelated within each view and are interrelated across views. Architecture products are those graphical, textual, and tabular items that are developed in the course of gathering architecture data, identifying their composition into related architecture components or composites, and modeling the relationships among those composites to describe characteristics pertinent to the architecture's intended use. [24:1-1]

DoDAF is composed of over 26 specific products, each product serving a separate purpose with different perspectives and layers of detail. As mentioned above by the DoDAF, the products are grouped within three main category views: Operational View (OV), Systems View (SV), and Technical Standards View (TV).

“The OV contains graphical and textual products that comprise an identification of the operational nodes and elements, assigned tasks and activities, and information flows required between nodes. It defines the types of information exchanged, the frequency of exchange, which tasks and activities are supported by the information exchanges, and the nature of information exchanges” [24:2-1]. The specific views within the OV represent the operational functionality of the system. Its views concentrate more on the functions and tasks that a system must perform in order to meet the overall user requirements.

“The SV associates system resources to the OV. These system resources support the operational activities and facilitate the exchange of information among operational nodes” [24:2-2]. The specific views within the SV begin to give the system a form. It builds on the functions designed in the OV's and assigns actual systems to perform those tasks.

“The TV includes a collection of the technical standards, implementation conventions, standards options, rules, and criteria organized into profile(s) that govern systems and system elements for a given architecture” [24:2-2]. The specific views within the TV give the reader the lowest level of detail when it comes to the actual specifications that the system design will either be built to or need to adhere to. Figure 3.1 shows how the views are linked.

Understanding how the views cover their respective areas and interact with one another helps in understanding the specific views. When one is looking at an OV, they should be thinking what is or needs to be done, but also that an SV and a TV will tell them what will do it and in what detailed way it will be done respectively.

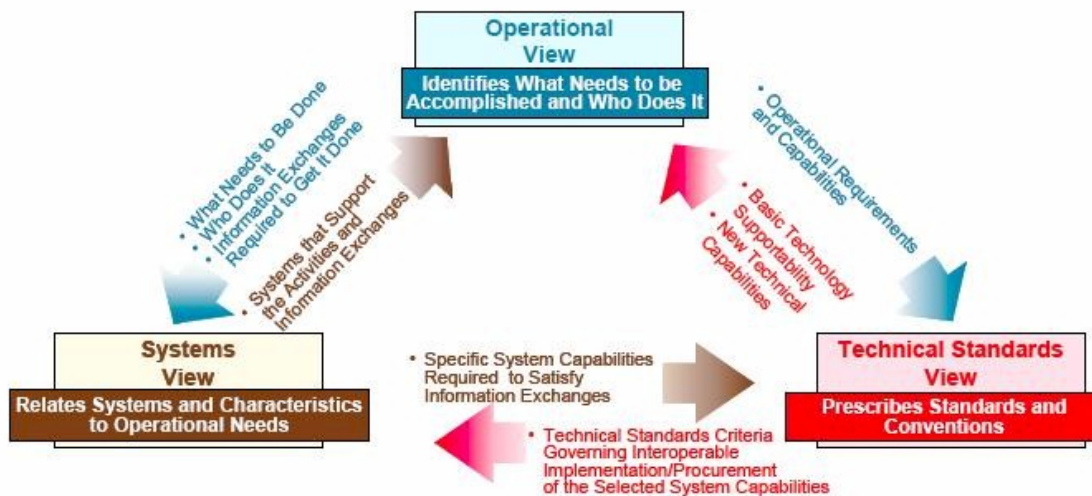

Figure 3.1 Fundamental Linkages Between Views

3.2.2 *Modeling Languages.* Now that the general makeup of an architecture is understood, their creation and languages can be discussed. Modeling languages used for architectures are similar to spoken languages. Two people speaking in different languages can compose and speak a sentence communicating the same thought. Regardless of the form that each word takes, there still needs to be basic elements represented (i.e. nouns, verbs, articles). Similarly, modeling languages may appear different and use

different approaches, but they can represent the same system through use of common elements. Within the systems engineering community DoDAF, there are two sets of modeling languages that are generally accepted in producing architectural views. These are the Unified Modeling Language (UML) and Integrated Computer Aided Manufacturing (ICAM) Definition (IDEF).

UML employs the object-oriented (OO) approach which is “a general-purpose modeling language for specifying, visualizing, constructing and documenting the artifacts of software systems, as well as for business modeling and other non-software systems” [34]. UML is widely accepted within the software development community it originated from. By focusing on the data elements and rule modeling needed to perform use-case scenarios, UML products work relatively easily into the executable software realm. Initially not included in the development of the C4ISR architecture, Doctors Michael Bienvenu, Insub Shin, and Alexander Levis showed that UML could be used to produce the required products for that architecture [8]. It is evident in the fact that DoDAF now includes UML as an accepted method of producing its products.

IDEF uses the structured analysis (SA) approach to produce its views. The SA approach uses the system’s activities and functions being performed as the building blocks of their views. The SA method builds upon two types of architecture constructs: the functional architecture and the physical architecture. “A functional architecture is a set of activities or functions, arranged in a specified partial order that, when activated, achieves a set of requirements. Similarly, a physical architecture is a representation of the physical resources, expressed as nodes, that constitute the system and their connectivity, expressed in the form of links” [31:228]. To create these two architectures there are several IDEF variants that focus on different areas of systems analysis. IDEF0 is a function modeling method that focuses on the activities of a system. IDEF1x is a data-modeling method that looks at a system as a collection of interacting data packages. IDEF3 is a process description capture method that focuses on how the system operates through actions and

events [4]. There are a few others as well, though they will not be used in the architectural products produced in this thesis.

Since the ISR MAV is a physical system and the UML language does not work ideally outside of the purely software environment, the SA approach through IDEF languages is used to produce the required architectural views. The SA approach and its functional and physical architectures relate very well to the DoDAF standard. The SA functional architecture and the DoDAF operational view are related in their role and representations. The SE physical architecture and the DoDAF systems view are also closely related in how they convey a system design in the integrated architecture.

3.2.3 Architectural Products. An integrated architecture is composed of several views, each represented by several distinct products. The DoDAF contains over 26 types of products, each with its own viewpoint and types of elements represented. In the DoD, the Joint Capabilities Integration and Development System (JCIDS) process directs integrated architectures and provides guidelines on what architectural products are

Table 3.1 JCIDS Required Products

<i>Product</i>	<i>Title</i>
AV-1	Overview and Summary Information
AV-2	Integrated Dictionary
OV-1	High-Level Operational Concept Graphic
OV-2	Operational Node Connectivity Diagram
OV-3	Operational Information Exchange Matrix*
OV-4	Organizational Relationships Chart
OV-5	Operational Activity Model
OV-6C	Operational Event Trace Description
SV-1	Systems Interface Description*
SV-4	Systems Functionality Description
SV-5	Operational Activity to Systems Functionality Traceability Matrix
SV-6	Systems Data Exchange Matrix

required and when. Treating this research in much the same as a Capability Development Document (CDD), the architectural products required for it were reviewed for a baseline [14:E-A-6]. Then looking ahead to the requirements for the next milestone, the minimum

required products for the CPD were used. These minimum products required by JCIDS policy for systems with top-level information exchange requirements in the Capability Production Document (CPD) [14] are listed in table 3.1.

In addition, the OV-7: Logical Data Model was developed because this product gives the best understanding of the actual data elements that pertain to the system. Each of the aforementioned products are explained below, including their DoDAF definitions, examples, and reasons why they are important for understanding the system.

AV-1 - Overview and Summary Information. The AV-1 (Figure 3.2) provides executive-level summary information in a consistent form that allows quick reference and comparison among architectures. The AV-1 includes assumptions, constraints, and

- 
- **Architecture Project Identification**
 - Name
 - Architect
 - Organization Developing the Architecture
 - Assumptions and Constraints
 - Approval Authority
 - Date Completed
 - Level of Effort and Projected and Actual Costs to Develop the Architecture
 - **Scope: Architecture View(s) and Products Identification**
 - Views and Products Developed
 - Time Frames Addressed
 - Organizations Involved
 - **Purpose and Viewpoint**
 - Purpose, Analysis, Questions to be Answered by Analysis of the Architecture
 - From Whose Viewpoint the Architecture is Developed
 - **Context**
 - Mission
 - Doctrine, Goals, and Vision
 - Rules, Criteria, and Conventions Followed
 - Tasking for Architecture Project and Linkages to Other Architectures
 - **Tools and File Formats Used**
 - **Findings**
 - Analysis Results
 - Recommendations

Figure 3.2 AV-1 - Template

limitations that may affect high-level decision processes involving the architecture [24:3-1]. This product is considered the title page of the architecture, and gives the reader a high-level overview of the following architecture.

AV-2 - Integrated Dictionary. This product contains definitions of terms used in the given architecture. It consists of textual definitions in the form of a glossary, a repository of architecture data, their taxonomies, and their metadata (i.e., data about architecture data), including metadata for tailored products, associated with the architecture products developed. Metadata are the architecture data types, possibly expressed in the form of

a physical schema [24:3-9]. This product is critical for traceability between all of the architecture products.

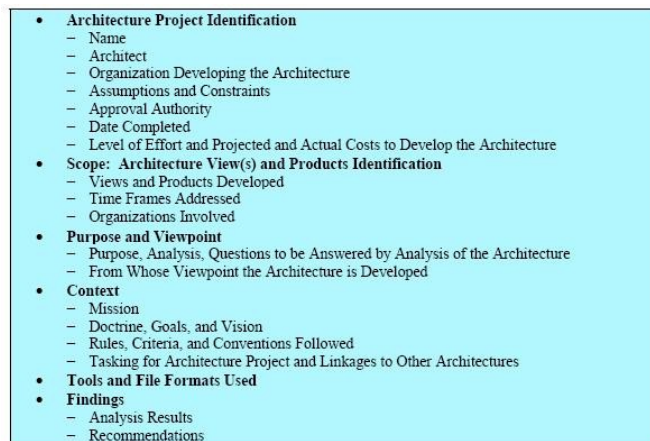
As the name *dictionary* infers, one should be able to use the AV-2 as a reference to understand the other products. Every data element or object found in each of the products should also be found defined in the AV-2. As an *integrated* dictionary, it also needs to relate the objects and the products so that the architectural products are tied together. Objects found in more than one product should have the same definition. An integrated dictionary can take many forms, but basic information about the data elements within should be consistent and as complete as possible to aid understanding of the element. The goals of this product are to document the architecture's contents, show their relation to one another, and, if necessary, serve as a textual representation of the entire architecture.

OV-1 - High-Level Operational Concept Graphic. The OV-1, an example of which is shown in Figure 3.3, describes a mission and highlights the main operational



Figure 3.3 OV-1 - Example

nodes and interesting or unique aspects of operations. It provides a description of the interactions between the subject architecture and its environment, and between the architecture and external systems. A textual description accompanying the graphic is crucial. Graphics alone are not sufficient for capturing the necessary architecture data [24:

4-1]. This product gives the reader a very basic, but operationally complete view of the system and is typically used in presentations to introduce the system and promote initial understanding. The OV-1 is particularly useful in communicating the unique aspects of the system to individuals unfamiliar with the system or architecture being discussed.

OV-2 - Operational Node Connectivity Diagram. This product, and example of which is shown in Figure 3.4, graphically depicts the operational nodes (or organizations) with needlines between those nodes that indicate a need to exchange information. The graphic includes internal operational nodes (internal to the architecture) as well as external nodes [24:4-7].

As one of the first products to be created in constructing an architecture, this product helps to shape the system model. It breaks the system into its most basic major players so

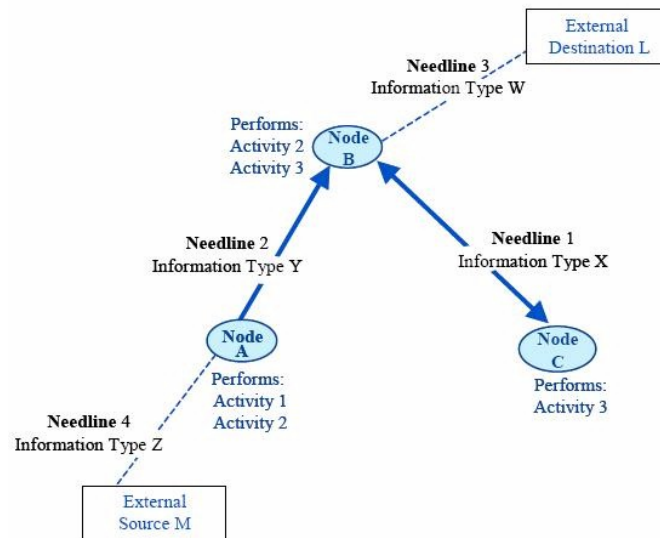

Figure 3.4 OV-2 - Template

that needlines of information, major interfaces, and areas of responsibility are broken out early. Much of the rest of the architecture is based directly on how the nodes and needlines interact.

OV-3 - Operational Information Exchange Matrix. This product details information exchanges and identifies “who exchanges what information, with whom, why

the information is necessary, and how the information exchange must occur” [15]. There is not a one-to-one mapping of OV-3 information exchanges to OV-2 needlines; rather, many individual information exchanges may be associated with one needline [24:4-16].

Figure 3.5 shows representative column headings for a typical OV-3 table. The rows list the OV-2 needlines and their sub information exchanges. The column headings

Needline Identifier	Information Exchange Identifier	Information Element Description					Producer		Consumer	
		Information Element Name and Identifier	Content	Scope	Accuracy	Language	Sending Op Node Name and Identifier	Sending Op Activity Name and Identifier	Receiving Op Node Name and Identifier	Receiving Op Activity Name and Identifier

Needline Identifier	Information Exchange Identifier	Nature of Transaction				Performance Attributes		Information Assurance			Security					
		Mission/Scenario UJTL or METL	Transaction Type	Triggering Event	Interoperability Level Required	Criticality	Periodicity	Timeliness	Access Control	Availability	Confidentiality	Dissemination Control	Integrity	Accountability	Protection (Type Name, Duration, Date)	Classification

Figure 3.5 OV-3 - Template

are generally tailored to the specific system type being modeled. For example, a template for a complex communication system will have more columns than a simpler system with few information exchanges. For this research the column headings with their meanings as defined by DoDAF [24] has been provided in Appendix F.

OV-4 - Organization Relationships Chart. This product illustrates the command structure or relationships among human roles, organizations, or organization types that are the key players in an architecture [24:4-27]. Many times this is a hierarchal organization chart illustrating the levels and layers of command interacting with the system. It is useful not only to understand the players with respect to the actual system, but also with the architecture itself. Many times this product has few, if any, direct links to other products; however, it is a valuable perspective of the organizational environment in which the system is designed, acquired and operated.

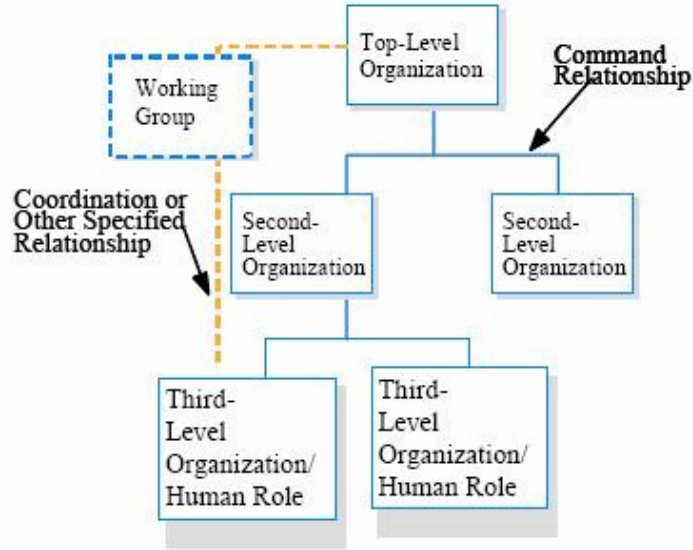

Figure 3.6 OV-4 - Template

OV-5 - Operational Activity Model. The OV-5 describes the operations that are normally conducted in the course of achieving a mission or a business goal. It describes capabilities, operational activities (or tasks), input and output (I/O) flows between activities, and I/O flows to/from activities that are outside the scope of the architecture [24:4-31].

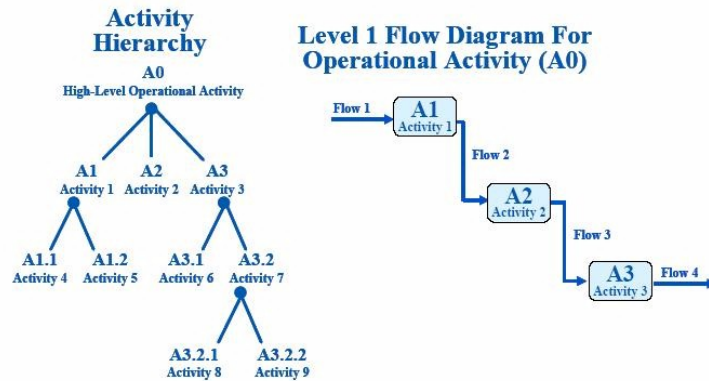

Figure 3.7 OV-5 - Template

This product shows the functional interaction of the system. It gives insight into what the system, and its subsystems, takes in as inputs and controls, and what mechanisms

it uses to produce outputs. This product is produced in hierarchical form, meaning that each view can be decomposed into children views to show sub function interaction. The product is represented in either its hierarchal form or its flow diagram form in which the inputs, controls, outputs, and mechanisms (ICOMs) show their interaction. This product is important for original capability decomposition, and also in understanding how the sub functions and activities interact. For this research, the language IDEF0 was used to create this product. Many times the ICOMs serve as a basis for system requirements generation.

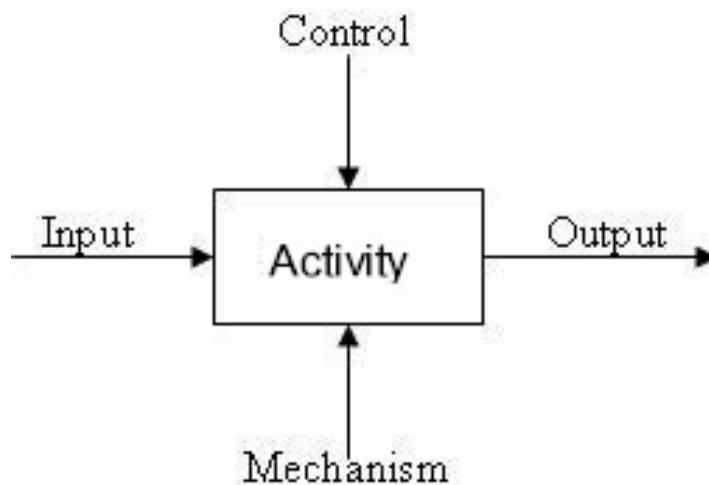

Figure 3.8 ICOM Notation

Figure 3.8 shows the standard notation for using ICOMs in an operational Activity Model. Inputs are depicted as entering the function box from the left, Controls entering from the top, outputs exiting the function and going to the right, and mechanisms entering the function from the bottom. ICOMS that enter or exit the function box at one level should also appear on any higher or lower level decomposition of that function. For cases where readability is an issue and a certain ICOM is not required for understanding at another level, it may be *tunneled*. This is indicated by parentheses placed around the head (entering) or tail (exiting) ICOM to be tunneled.

OV-6C - Operational Event Trace Description. The OV-6C provides a time-ordered examination of the information exchanges between participating operational nodes as a result of a particular scenario. Each event-trace diagram should have an accompanying description that defines the particular scenario or situation [24:4-55]. It essentially takes the major nodes from the OV-2 and turns them into swim lanes within which the actions of the scenarios are played out.

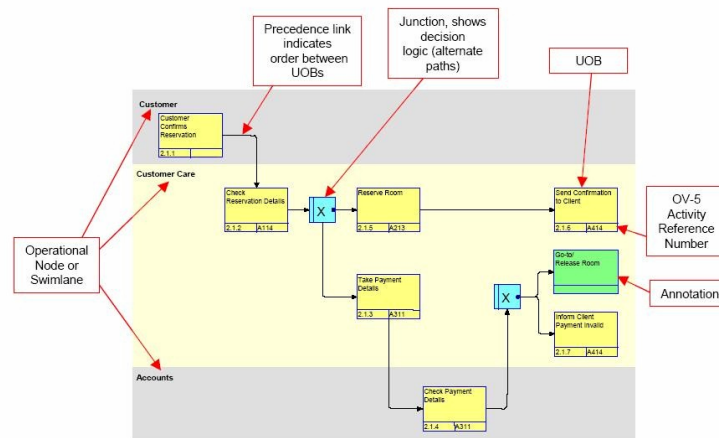

Figure 3.9 OV-6c - IDEF3 Example

The purpose of the OV-6C is to show the critical path(s) through a given scenario. While in other products the connector lines many times represent communication, info, or needlines, in this view they are only precedent links that allow subsequent tasks to take place. Junctions are also used to illustrate alternated paths. Each action is also traced to functions on the OV-5. Once this product is made, it is easy to validate each action in the OV-6 with a function from the OV-5. For this research, the language IDEF3 was used to create this product.

OV-7 - Logical Data Model. The OV-7 describes the structure of an architecture domain's system data types and the structural business process rules (defined in the architecture's Operational View) that govern the system data. It provides a definition of architecture domain data types, their attributes or characteristics, and their interrelationships [24:4-62]. While not a specifically required product for the CDD per CJCSM

3170, the OV-7 is included because of its importance to any system design effort where software is involved.

The system's ICOM's, found in the OV-5, are represented in the OV-7 as either individual data types, or as attributes within other data types. The OV-7 can be used by the software development effort, therefore the diagram deals in what types and links of data must be present for the system to operate. The developers can then use this information to develop the actual programming and coding of the software portion of the system. For this research, the language IDEF1x was used to create this product.

Relationships represented in an OV-7 serve to show how one data entity, or data package, depends on other packages. Attributes in some packages are required by other packages to identify a specific instantiation of the data. These identifying attributes are called primary keys. When a data package depends on another package, the primary key is translated to the depending package as a primary foreign key.

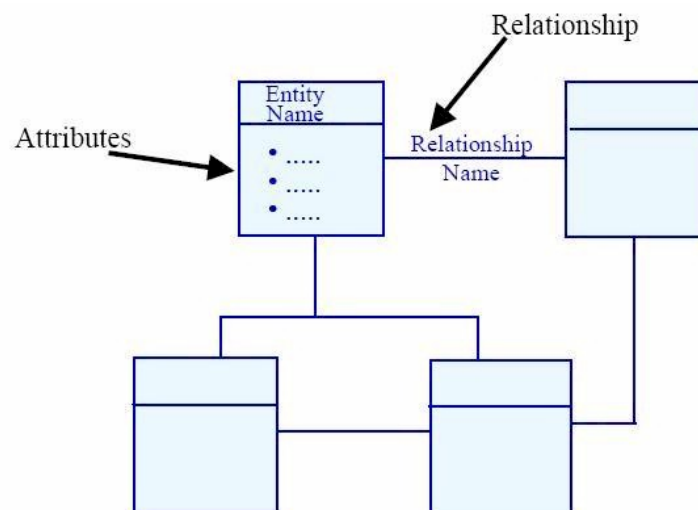

Figure 3.10 OV-7 - Template

There are also relationships of a hierarchical nature, where data packages linked to a higher-level package contain all of the attributes of the higher package with the addition of one specifically listed in the lower-level packages. This relationship is represented as the

lower-level packages bracketing into a circle with a short line over it and a line out of this symbol goes to the higher-level package. Any relationships to the higher-level package automatically exist to the lower-level packages.

Required attributes are shown in bold. Multiplicity of certain data packages are labeled on the relationship links. They indicate the acceptable number of instantiations of the data package that the relationship supports.

SV-1 - Systems Interface Description. The SV-1 depicts systems nodes and the systems resident at these nodes to support organizations and/or human roles represented by operational nodes of the Operational Node Connectivity Description (OV-2). SV-1 also identifies the interfaces between systems and systems nodes [24:5-1]. As the first product within the systems view, the SV-1 is important because it begins the process of forming the operational view of the system into an actual physical system. Operational nodes and activities from the operational view are translated and transformed into systems and system functions. The SV-1 begins that process through its assignment of system functional responsibility among the nodes and interfaces.

Several versions of the System Interface Description, as shown in Figures 3.11 through 3.14, can be developed to show various levels of detail for the system under design. The SV-1 may represent the internodal view of the system showing node to node

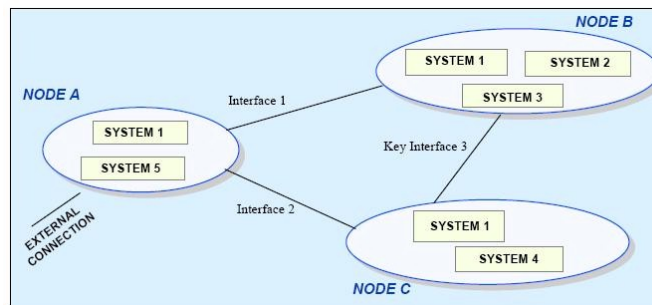

Figure 3.11 SV-1a - Internodal Template Showing Node Interfaces

interfaces (Figure 3.11), system to system interfaces (Figure 3.12), interfaces within each node (Figure 3.13), or an intrasystem view showing hardware and software items within

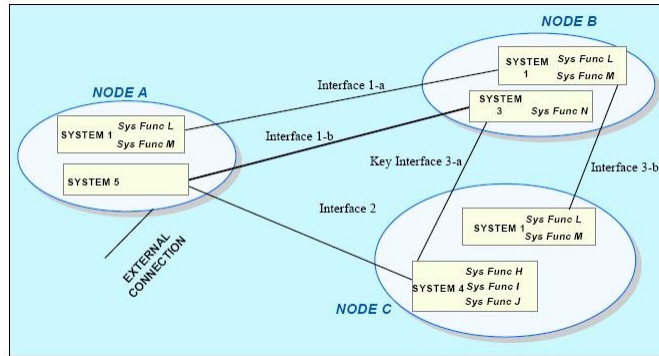

Figure 3.12 SV-1b - Internodal Template Showing System Interfaces

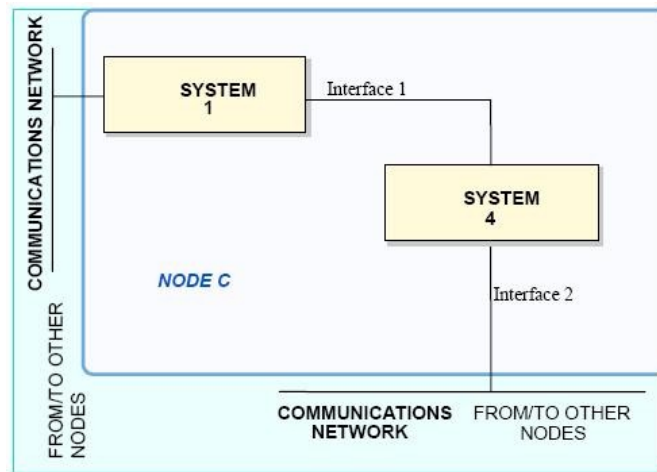

Figure 3.13 SV-1c - Intranodal Template

each node (Figure 3.14). While the DoDAF does not distinguish between the various versions other than by name, for the purposes of this thesis, they will be referred to as an SV-1a, SV-1b, SV-1c and SV-1d respectively.

The SV-1a provides a generic internodal view that illustrates node to node interfaces. The applicable systems that make up each node are shown but the system-to-system interfaces are withheld. Additional information, such as system functions, can also be included in each of the nodes should the architect find this information useful in clarifying the view. The SV-1b expands on the SV-1a by providing the interfaces from the node boundaries to each system contained therein. The intranodal version, or SV-1c, provides

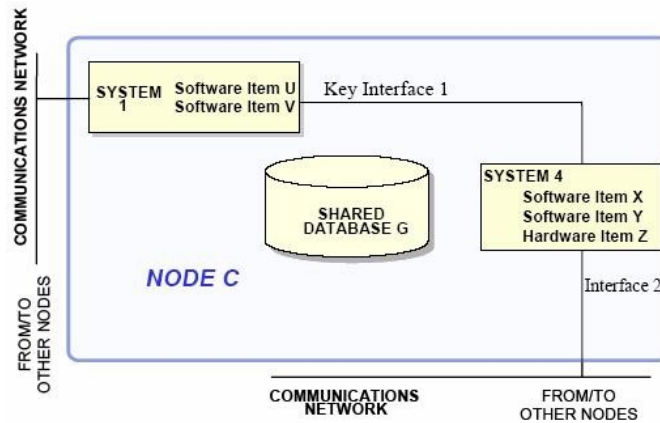

Figure 3.14 SV-1d - Intrasystem Example

a detailed look at each node by showing interfaces between systems within the nodal boundaries and can include references to each system if desired. Finally, the SV-1d intrasystem view shows systems hardware and software that interface within each node and provides a more detailed view that begins to resemble a physical system.

SV-4 - Systems Functionality Description. The SV-4 documents system functional hierarchies, system functions and the system data flows between them. Although there is a correlation between the Operational Activity Model (OV-5) and the system functional

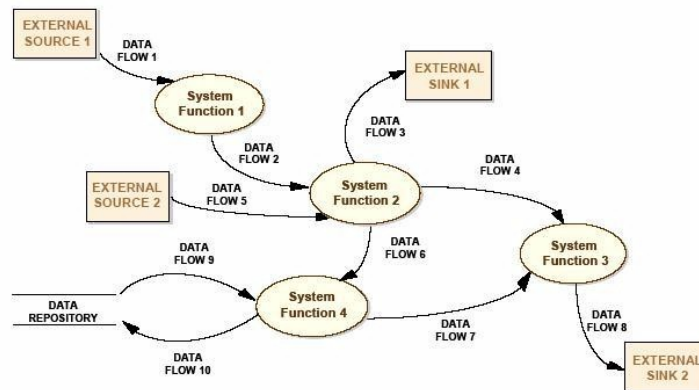

Figure 3.15 SV-4 - Template (Data Flow Diagram)

hierarchy of SV-4, it need not be a one-to-one mapping, hence, the need for the Operational Activity to Systems Function Traceability Matrix (SV-5), which provides that mapping

[24:5-25]. In the way that the OV-5 decomposed and related its activities in the operational view, the SV-4 takes the system functions from the SV-1 and decomposes and relates them. One difference between the OV-5 and SV-4 is that the former looks at the entire system's activities, while the latter's primary focus is on data exchange.

The view takes one more step in the systems view to assigning functional responsibilities to systems and subsystems. The data that moves between SV-4 functions are more exact in nature than were found in the operational view. These data links are described in much detail in the Systems Data Exchange Matrix (SV-6), and will be ultimately used in the actual design of subsystem interface specifications. Similar to the OV-5, the SV-4 is also hierarchal, so each function can be broken down into its children views. In other words, unlike the OV-5 where ICOMs enter and leave views without reference to their origin or destinations, the SV-4 shows the data exchange lines coming from or going to their external systems or other subsystem functions.

SV-5 - Operational Activity to Systems Function Traceability Matrix. The SV-5 provides a specification of the relationships between the set of operational activities

System Functions	Operational Activities																
	3.1.1	3.1.1.3	3.1.2	3.1.2.1	3.1.2.2	3.1.2.3	3.1.3	3.1.4	3.1.4.1	3.1.4.2	3.1.4.3	3.1.4.4	3.1.5	3.1.6	3.1.7	3.1.7.1	
1	X																
1.1		X															
1.1.1			X														
1.1.1.1	X																
1.1.1.2				X													
1.1.1.3							X										
1.1.2										X							
1.1.2.1				X													
1.1.2.2					X												
1.1.2.3								X									
1.1.3											X						
1.1.3.1												X					
1.1.3.2									X								
1.1.3.3															X		
1.1.3.4															X		

Figure 3.16 SV-5 - Template

applicable to an architecture and the set of system functions applicable to that architecture [24:5-35]. This product is useful in ensuring the architecture's traceability. It serves as a feedback mechanism to the original requirements and provides a link between the OV-5 and SV-4 products. It is important to ensure that the activities designed in the operational view are accounted for in the system view in some form of function. This also helps justify why system functions are present in the system view and to determine any unwarranted functions.

SV-6 - Systems Data Exchange Matrix. The SV-6 specifies the characteristics of the system data exchanged between systems and focuses on automated information exchanges (from OV-3) that are implemented in systems. Non-automated information exchanges, such as verbal orders, are captured in the OV products only [24:5-41]. This product gives a great deal of detail about the data exchanges that have been designed in the system view. This matrix accounts for all of them and will serve as a link to the technical standards view when actual subsystem and component interface descriptions are determined.

As with the OV-3 Operational Exchange Matrix, the column headings are generally tailored to the specific system type being modeled. For this research the column headings with their meanings as defined by DoDAF [24] have been provided in Appendix N.

IV. Results

This chapter begins with an analysis of the three mission scenarios (over-the-hill reconnaissance, battle damage information and local area defense), focusing on the entry conditions and a typical mission profile for each scenario. Following the mission scenario analysis are the traceability results that seek to tie the missions, and ensuing architectures, to specific Air Force tasks. Inherent with the identified tasks are associated measures that can be used to determine the degree to which MAVs accomplish those tasks. Additionally, the aforementioned scenarios have potential ties to the Joint Functional Concepts (JFC). While traceability to JFCs was not performed for this project, the act of performing this additional analysis can provide additional insights into areas where the use of MAVs would prove valuable. Chapter III presented the generic format for the Department of Defense Architecture Framework (DoDAF) products whereas this chapter presents the architectural products developed for the ISR MAV. A discussion on the impacts MAVs have on doctrine, organization, training, material, leadership/education, personnel and facilities (DOTMLPF) is then presented followed by an examination of future MAV capabilities related to technology and operational use as constrained by the scope and architectures used to define ISR MAVs.

4.1 Operational Scenarios

Three operational scenarios were developed that are related to both the applicable special operations forces core tasks and capability deficiencies outlined in Sections 2.1.2 and 2.1.3. A description of each operational scenario is provided that includes entry conditions and pertinent information regarding key operational aspects of the employment of MAVs and their ability to provide unit-level, close proximity, actionable intelligence. From these scenarios, a list of requirements can begin to be formulated. However, the MAV architecture provides for more in-depth requirements analysis and refinement. While this analysis was not specifically performed, a brief discussion of the merits of

using architectures to develop and refine requirements and their associated measures will be provided in Chapter V.

4.1.1 Over-the-Hill Reconnaissance. In this mission, the MAV enhances a special operations team's situational awareness of their immediate surroundings. The set-up for this mission assumes that a small friendly force is on a patrol mission into uncleared territory. The patrol moves to a specific location without full advance intelligence of the area they are moving through. The mission scenario also includes the team reaching their objective location and performing surveillance while concealed.

The entry condition to this scenario starts with a friendly team members' decision to obtain local area reconnaissance above the team's current location or areas they are moving into. The MAV is at hand and is launched after its prep time. It is flown either manually or automatically using a looping area search pattern above the team's location (or slightly ahead of the team). The operator observes the video feedback from the MAV thus enhancing the team's situational awareness. Should the operator observe an enemy presence, the video feed with accompanying geo-location information can be relayed to those requiring the information to possibly attack the enemy location. The decision to relay this information is purely up to operator discretion (i.e. not an automatic link). A similar use of the MAV occurs once reaching their objective location and the team decides to better observe their target.

Throughout the flight time of the MAV, the video feedback should enable operating personnel a suitable level of target discrimination to positively identify key characteristics of enemy and their equipment. Examples might be discriminating between major objects, vehicles, buildings, and weapon systems. Once the MAV obtains sufficient information in the team's general vicinity, or the MAV limits are reached, the operator can either return the MAV to the base or choose to continue loitering the MAV until complete power failure (i.e. expend the MAV). Assuming the MAV returns and is recovered, the SOF team *refuels/recharges* the MAV for immediate further flights or stores the MAV for travel.

4.1.2 Battle Damage Information. In this mission, the MAV is used to gather battle damage information following an attack on an enemy location. The set-up for this mission assumes that a friendly force patrol already knows the location of an enemy and has already launched or is currently launching a strike on the enemy. The strike could be a called-in air strike, a called-in artillery attack, or a direct attack from their current location. The team is close enough to the enemy location that the MAV is within range.

The entry condition to this scenario starts with a friendly team member's decision to obtain Battle Damage Information (BDI) on the enemy location already attacked or currently under attack. The MAV is at hand and is launched after its initialization sequence. It is flown either manually or automatically to the attack sight based on enemy location information. Once in the general vicinity of the enemy location, the MAV begins an observation pattern over the enemy location (either manually or automatically controlled). The video feedback from the MAV provides BDI from which the operator may determine the need to change MAV system parameters to gain more use BDI. The video feed with accompanying geo-location information is then relayed to those requiring the information to possibly complete the mission or plan further attack of the enemy location.

Throughout the flight time of the MAV, the video feedback should be such that operating personnel can positively identify the enemy and major objects, cars, buildings, large weapons, etc. Once sufficient BDI is obtained on the enemy location and/or the MAV has reached its limits, the operator can either return the MAV to the base or choose to continue loitering the MAV until complete power failure (i.e. expend the MAV).

4.1.3 Local Area Defense. In this mission, the MAV is used to augment the Local Area Defense (LAD) mission by providing near immediate airborne intelligence to the security personnel. The set-up for the mission assumes a fortified position for friendly forces that is currently guarded by traditional security forces. The position may be near

populated areas and it may also be near terrain and vegetation which limits the line of sight capabilities of the security personnel.

The entry condition to this scenario starts with a ground attack launched against a friendly location or base. Determining where the attack is launched from could be accomplished either by visible reports or roughly calculating the direction of enemy fire. The operator then uses this information to initialize and load the MAV flight parameters or they operate the MAV manually which may enable a quicker launch. The operator then deploys the MAV and monitors the video stream on the display device. While deployed, the operator can change the MAV's route by changing navigational waypoints or command the MAV to return to a pre-defined landing zone. Once in the general vicinity of the suspected enemy location, the video feedback from the MAV allows the operator to conduct a visual search for the enemy or threat which may be mobile or stationary, concealed or exposed. The MAV operator continues to track the enemy position until the threat is eliminated, the MAV has expended its fuel, or the MAV is beyond its transmitting range. While available, the video feed, with accompanying geo-location information, is then used by the appropriate security personnel to launch an attack from the compound or to plan a later attack on the enemy's hiding place.

Throughout the flight time of the MAV, the video feedback should be such that the LAD personnel can positively identify the enemy. Once sufficient information has been obtained on the enemy location and/or the MAV has reached its limits, the operator can either return the MAV to the base or choose to continue loitering the MAV until complete power failure (i.e. expend the MAV).

4.2 MAV Traceability

The purpose of traceability in design is to ensure that the system being designed to fill an identified capability gap can be traced back to the tasks relevant to the systems operational concepts and scenarios. Additionally, traceability is an integral part of the Joint Capabilities Integration and Development System (JCIDS) and the integrated

architectures produced to answer the gap. As such, the capability gap initiates the JCIDS process and ensuing traceability analysis. Two primary parts of the JCIDS process pertinent to this thesis were the creation of an ISR MAV integrated architecture and the performance of traceability analysis related to the previously discussed mission scenarios. However, traceability typically occurs before a solution has been chosen which was not the case for this effort since MAVs were identified up front as the solution to the tactical ISR capability gap. Therefore, a quick discussion of the differences between current UAVs and MAVs is provided which is followed by a discussion of the traceability analysis as related to the Air Force Task List (AFTL) and special operations core tasks.

What is driving all of the development effort behind MAVs? They surely are not more capable than their larger brothers; they have shorter mission endurance and they can not carry the quantity or the quality of sensors that the larger aircraft can. The allure of MAVs lies in their small operational and logistic footprints and potential for high availability.

A quick comparison of several important parameters of currently operating UAVs is presented in Figure 4.1 provides. The larger UAVs such as the Global Hawk and Predator are more suited to long endurance missions requiring multiple sensors. These are mainly

System Description	Endurance	Payload	Man-packable	Availability	Weight (empty aircraft only)	Sensor Payload
Global Hawk (RQ-4)	42 hours	Electro-optical (EO) Synthetic Aperature Radar (SAR) Moving Target Indicator Infrared (IR)	No	Low	25,600 lb	2000 lb
Predator (RQ-1)	24 hours	Electro-optical (EO) Synthetic Aperature Radar (SAR) Infrared (IR)	No	Low	1,130 lb	450 lb
Pointer (FQM-151A)	1-5 hours	Electro-optical (EO) Infrared (IR)	Yes 2 x 50lb packs	Medium	10 lb	2 lb
MAV	< 0.5 hours	Electro-optical (EO)	Yes	High	< 2 lb	< 1 lb

Figure 4.1 UAV Specification Comparison

used for battlefield-level surveillance and reconnaissance. However, these have a very large logistic footprint requiring fixed landing fields and dedicated operators [6] [5]. As

UAVs get smaller, their performance and endurance capabilities are drastically decreased when compared to their larger brothers. However, the advantage is that these smaller UAVs are carried into the field with the unit. The term man-packable is pushed to its limits with the Pointer system as it requires a vehicle for transportation into the theater and two soldiers carrying 50 lb packs when the unit is on foot. Availability for the Pointer is medium since their usage is limited to specialized units. The only mini/micro UAV in the group is the generic MAV. It performs much the same mission as the Pointer; however, it sacrifices mission endurance to gain extremely small size, light weight and affordability.

All of the previously mentioned systems perform an ISR mission for their users. The fact that different users have different requirements gives rise to a UAV family of systems. The DoD currently has the capability to perform battlefield level surveillance with the two larger platforms. The Pointer system was a start at miniaturizing UAV technologies to allow individual units to perform tactical surveillance and reconnaissance. However, the large size of the system and the extensive set-up and tear-down time made it unsuitable for quick reaction missions. The need for the SOF team is to have a quick reaction system to gather tactical surveillance and reconnaissance within an operationally significant range that does not require the team to give up other mission essential equipment. Therefore, MAVs provide a viable concept that can feel the aforementioned need.

As discussed earlier, traceability begins prior to selecting the concept or alternative to answer the capability gap. Traceability, as shown in Figure 4.2, ties the scenarios that describe the capability gap, to both the organizations that perform the missions and the applicable tasks as defined in the AFTL. The US Special Operations Command (USSOCOM) has a wide range of mission areas; however, two core tasks (mission areas) match closely with the three missions discussed in this paper. *Counter-Terrorism* addresses both the MAV reconnaissance and local area defense missions. *Special reconnaissance* ties into the previous two missions and adds the battle damage information mission. Two primary tasks and several specific sub-tasks were selected from the AFTL which relate to the three mission areas. Once this portion of the traceability is completed,

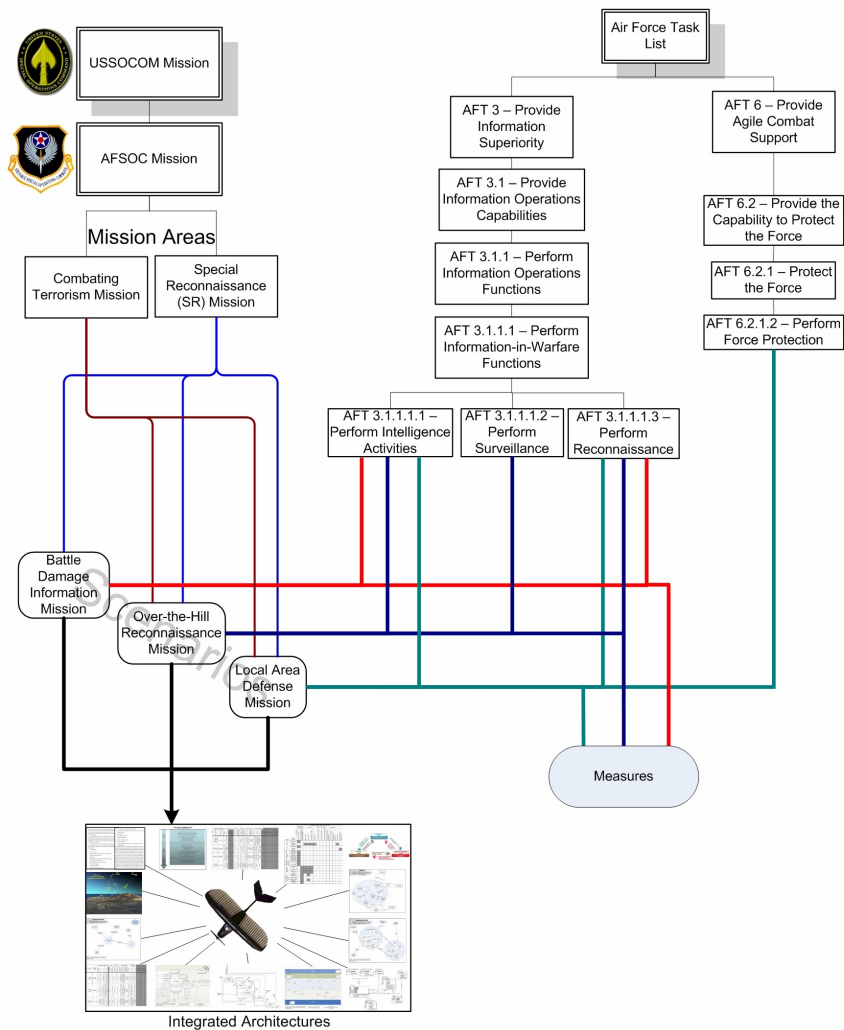

Figure 4.2 Mission/Scenario to Air Force Task Traceability

some of the (abbreviated list of) measures provided in the AFTL and shown in Table 4.1 can be used as discriminators to determine which alternative concept best fills the gap. Remember that MAVs were provided as the solution to fill the gap which in essence eliminated the need to perform Functional Area Analysis (FAA), Functional Needs Analysis (FNA), and Functional Solution Analysis (FSA) as well as an Analysis of Alternatives (AoA).

Following the selection of a concept (or system) to fill the capability gap, an integrated architecture is produced. The architecture, along with the mission scenarios,

Table 4.1 AFTL Measures [40:103-104]

<i>Task</i>	<i>Criterion</i>	<i>Measure</i>
AFT 3.1.1.1.1 Perform Intelligence Activities	Time	To conduct adequate, timely, and reliable intelligence activities for the USAF and other agencies.
	Percent	Of accuracy to which adversary COGs are identified to accomplish predetermined objectives.
	Cost	To Perform tactical intelligence activities.
AFT 3.1.1.1.2 Perform Surveillance	Time	To systematically observe air, or surface areas, places, persons, or things by visual, aural, electronic, photographic, or other means.
	Percent	Of accuracy to which air or surface areas, places, persons, or things can be observed by visual, aural, electronic, photographic, or other means.
	Cost	To perform surveillance.
AFT 3.1.1.1.3 Perform Reconnaissance	Time	To obtain, by visual observation or other detection methods, specific information about the activities and resources of an adversary or potential adversary.
	Percent	Of accuracy to which specific information about the activities and resources of an adversary or potential adversary is obtained.
	Cost	To perform reconnaissance.

is then be used to develop system requirements. Requirements generated from the initial ISR MAV architecture will allow the discipline or test engineers the ability to define the measures needed to evaluate system performance which ultimately ties back to the ability to fill the capability gap. The ISR MAV architecture requirements will also be classified into either functional, system, or derived requirements. Once the requirements are established, measures of effectiveness (MOE) relating to requirements provide a means for determining the operational effectiveness and suitability of the system. These top-level measures also embody characteristics such as being quantitative, mission-oriented, and testable (objectively or subjectively). Traceability, for the purposes of this project,

was focused on creating the links between scenarios and tasks, and scenarios and the user organizational structure. Additionally, the architecture provides the groundwork for identifying and refining system level requirements and their associated MOEs.

4.3 *Current ISR MAV Architecture*

The following subsections discuss the architectural products that describe an ISR MAV system in its current state. Each subsection introduces the specific product and provides its respective diagrams and/or descriptive texts. Areas of note will be highlighted to help understand each view. A fully expanded version of each product and their respective integrated dictionaries may be found in the appendices.

4.3.1 AV-1 Overview and Summary Information. This architectural product gives the top-level information required to understand the background, purpose, and scope of the entire architecture. Since it is text-based and relatively short in length, it has been included here in its entirety. It is also shown in Appendix C.

AV-1: Overview and Summary Information for ISR MAV (AS-IS)

1. Identification

Name: Intelligence, Surveillance and Reconnaissance Micro/Mini Aerial Vehicle (AS-IS)

Short Name: ISR MAV (AS-IS) Architecture

Involved Organizations:

AFRL/MN; Munitions Directorate

AFRL/HE; Human Effectiveness Directorate

ASC/AAP; Aeronautical Enterprise Program Office, System Program Office (SPO)

AFIT/ENY-GSE; USAF Graduate Systems Engineering program; architecture developers.

Date: This version targets the FY05 timeframe. The period for the development of this version of the architecture was August 2004 to March 2005.

2. Background: Currently, no integrated architecture exists to define the use of the emerging field of MAVs within the Department of Defense or the US Air Force. MAVs

are rapidly emerging as a productive subset of the larger category of Unmanned Aerial Vehicles (UAV). They are loosely defined as being small enough in size and weight to be man-packable for use in austere operational environments by Special Forces personnel. The MAV's size and ease of testability allows for rapid development and modification of design and application.

This architecture is an AS-IS representation of a generic ISR-focused MAV. This baseline architecture is used to understand the system, track changes to any fielded systems, and to determine future capability shortfalls that should be addressed.

3. Purpose: This ISR MAV architecture provides a baseline for the current capabilities of operational ISR MAVs. The purpose of this version of the architecture (FY05) is detailed in Table 4.2 below.

4. Scope: The products associated with this architecture depict the AS-IS state of a generic ISR MAV system. This architecture includes the infrastructure and systems needed to operate an ISR MAV by US military personnel.

5. Time Frame: The architecture depicts the weapon system in its current state and certain evolutions expected to be implemented through FY05.

Table 4.2 Architecture Purposes

<i>Architecture Purpose</i>	<i>Architecture Product Implications</i>
Describe a generic ISR MAV system as a baseline to fully map the necessary interfaces needed to describe the ISR MAV mission	Architectural elements are documented that are common to the ISR MAV mission and can be used to fully understand the system's boundaries and interfaces. Specifically the OV-2, OV-5, and SV-1 depict these interfaces.
Support the development of an ISR MAV Full Scale Production Contract and serve as a maintained, authoritative decision making tool after contract award	Information must be accurate and authoritative. Products were built with the idea in mind that the future changes to the mission profile and integrating advanced technology will need to be reflected in the baseline architectures prior to implementation
Support the design of tailored ISR MAV implementations	The generic architecture should be extensible to reflect C2 node or site specific variations of ISR MAVs without losing linkage and consistency with the baseline architecture products
Provide traceability of requirements to architecture components	To be meaningful, the granularity of the architectural elements should be small
Support the development of future test plans	OV-2, OV-3, SV-1 and SV-6 will aid in determining system connectivity and interoperability requirements
Identify modernization opportunities	Certain architecture elements are candidates for replacement, re-engineering, or additional capabilities as discussed in the accompanying future capabilities discussion
Support future acquisition activities by contributing to the refinement of ISR MAV requirements helping identify areas for modernization	Requires significant granularity across a variety of OV and SV products
Be an integral part of the larger ISR and/or UAV architectures	Use of same or interoperable toolsets, terminology, and supporting architecture databases where available

4.3.2 *AV-2 Integrated Dictionaries.* While the Integrated Dictionary can be represented as a stand-alone product, describing the rest of the architecture in only text, here it is broken into its respective products. Each product presented in the architecture has an accompanying AV-2 following it to describe in detail each of the objects, connections, and other representation of each product. DoDAF provides a basic template for each product's AV-2 which was tailored to fit the scope of the ISR MAV architecture. At a minimum, every representation in a product has an accompanying description, type, and reference to which other views include it. In this way, many basic questions in understanding the products and what their elements represent can be answered by referring to the respective AV-2 in the appendix.

4.3.3 *OV-1 High-Level Operational Concept.* Creating the architectures for each of the previously discussed scenarios begins with the creation of the high-level operational concept graphic (OV-1) and its associated text description. The over-the-hill reconnaissance and battle damage information (BDI) missions were combined due to the close relationship between these missions and are shown in Figure 4.3. To perform

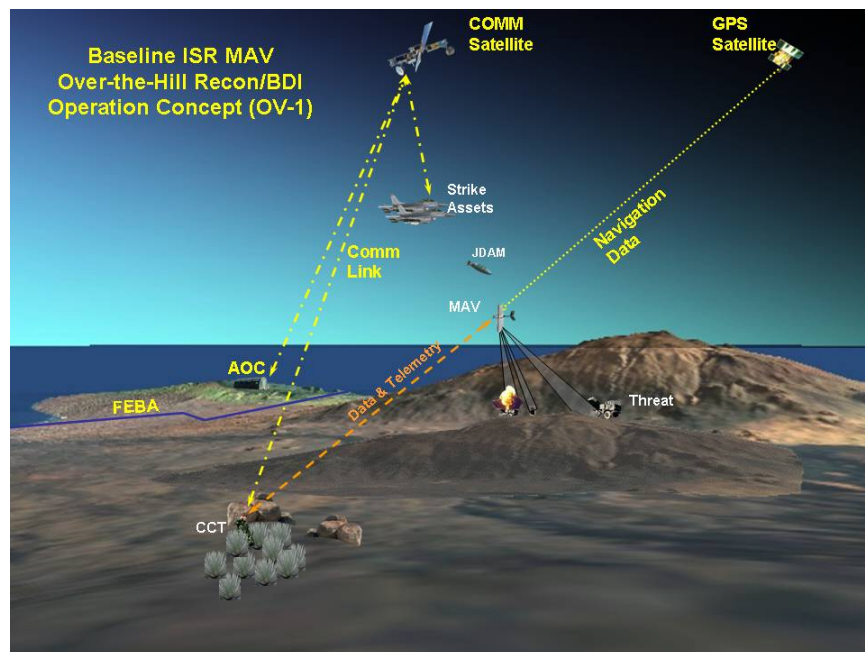

Figure 4.3 OV-1 for the OTHISR and BDI Scenario

BDI with the MAV system, a potential target's location must be known and be within the MAV's sensor range. The two MAV nodes shown in the graphic are the combat controller (or the friendly ground unit in subsequent views) and the MAV (or aerial vehicle). External systems consist of GPS satellites, the air operations center (AOC) (or headquarters in subsequent views), and strike assets. In addition to providing internal and external nodes, the graphic provides a vision of node connectivity and a top-level view for how the MAV system operates.

The OV-1 for the LAD scenario (Figure 4.4) looks very similar to the over-the-hill reconnaissance and BDI scenarios with the exception of how the user utilizes the MAV

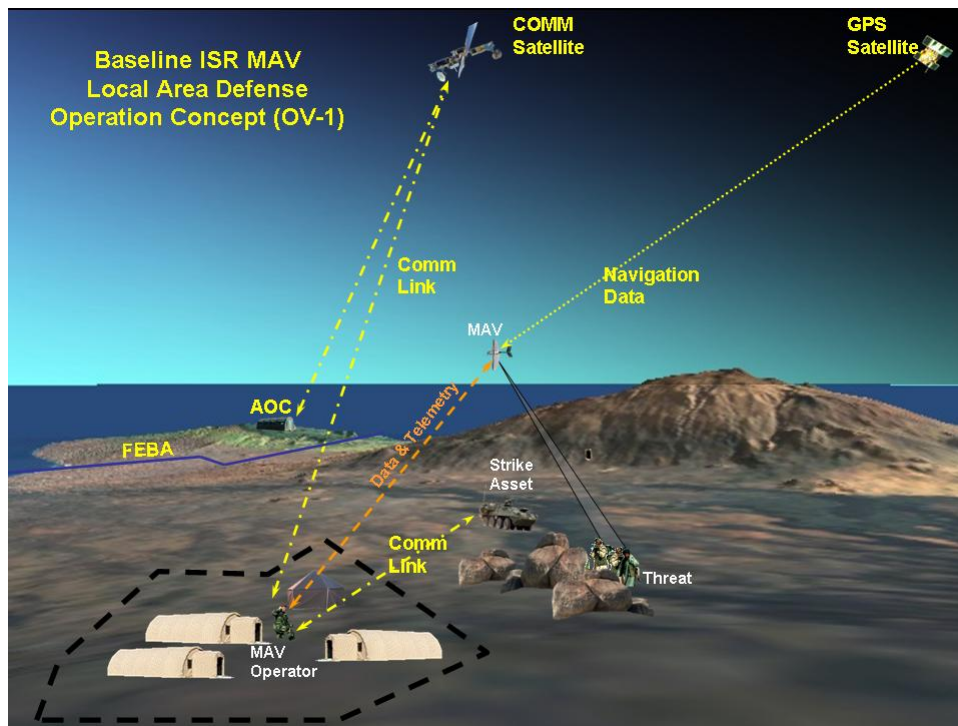

Figure 4.4 OV-1 for the LAD Scenario

system. All three scenarios require the MAV system to provide information which can be used to provide better situational awareness for the ground unit and/or to aid in the engagement of threats and ensuing assessment of the engagements. However, in the over-the-hill reconnaissance and BDI scenarios, concealment was paramount for the ground

unit. In the LAD scenario, the enemy is attacking a known location or local area which drives the requirement to quickly obtain information pertaining to the threat.

4.3.4 *OV-2 Operational Node Connectivity.* The OV-2 depicts operational nodes (internal and external) and needlines in order to show a need to exchange information. Since there is only a single needline between two nodes it can contain many different types and formats of information. The Operational Information Exchange Matrix (OV-3) presented later, breaks apart the different types of information within each needline. An OV-2 diagram was produced for each of the three operating scenarios and these three diagrams were then compiled into a *Consolidated OV-2* which reflects and integrates all of the scenarios.

Over-the-Hill Reconnaissance OV-2: The first OV-2 Figure, 4.5, is based on the over-the-hill reconnaissance scenario. From the scenario, two internal operational nodes can be picked out based on relative operational function or activity. The *Special Ops Unit*

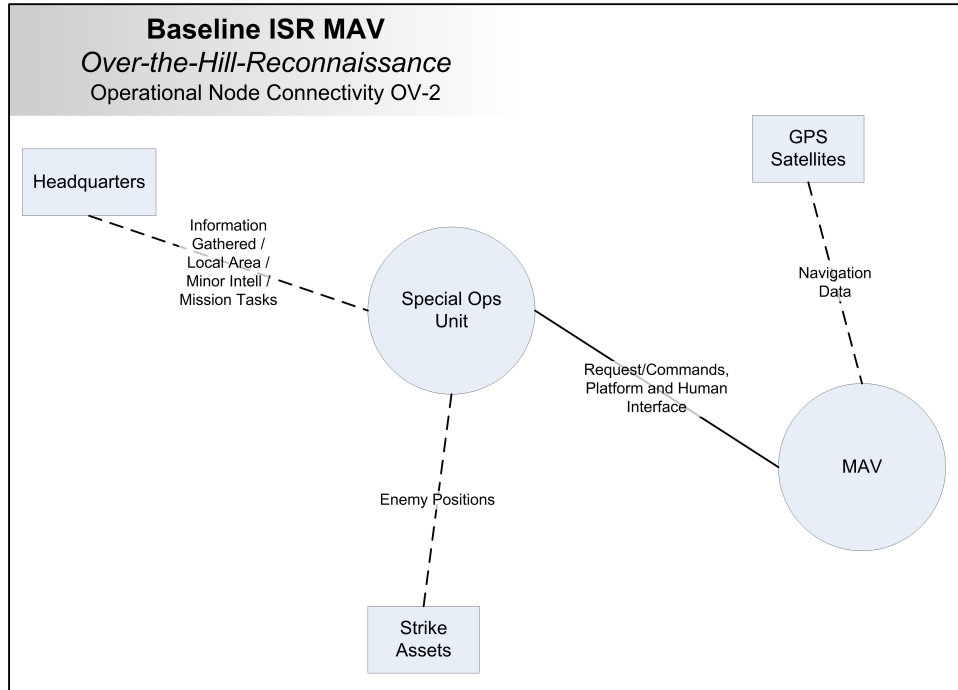

Figure 4.5 OV-2 for the Over-the-Hill Reconnaissance Scenario

node comprises all operations needing to be performed on the ground. This is also referred to as the ground aspect of the system and includes the operator/user. The *MAV* node, however, is referred to as the air aspect of the system thus containing all operations needed to be done while in flight. These two nodes need to be able to communicate so the operator can control the airborne node as well as retrieve reconnaissance data from it, hence the needline *Request/Commands, Platform and Human Interface*. Based on the scenario, there are also three external nodes. The first external node, *Headquarters*, consists of the *Special Ops Units* higher headquarters which distributes intelligence, mission tasks, and receives reconnaissance information once gathered. The second external node, *Strike Assets*, has the option to either receive or relay last known enemy positions with the *Special Ops Unit*. By receiving the enemy positions the *Strike Assets* are provided the information needed to strike the target. In contrast, the *Strike Assets* are able to send enemy positions to the *Special Ops Unit*, thereby increasing the situational awareness of the unit and easing their reconnaissance operations. The third external node, *GPS Satellites*, provides the *MAV* with navigation data so that both the *Special Ops Unit* and *MAV* know where it is located. Note that the figure helps illustrate these information exchanges through the use of needlines.

Battle Damage Information OV-2: Figure 4.6 is based on the battle damage information scenario. From the scenario similar internal and external operational nodes and needlines can be picked out based on the same logic as in the Over-the-Hill Reconnaissance OV-2. Although similar to the preceding scenario it is important to see the different information needs (needlines) required by two of the three external nodes (there was no change with the *GPS Satellite* node). The *Headquarters* node consists of the *Friendly Ground Units* higher headquarters which places a request for battle damage information and receives the information once it has been collected. The other change was in the *Strike Assets* node which also has the option to request battle damage information, relay strike status (when scheduled or if it has already occurred), and receive general feedback on the information gathered.

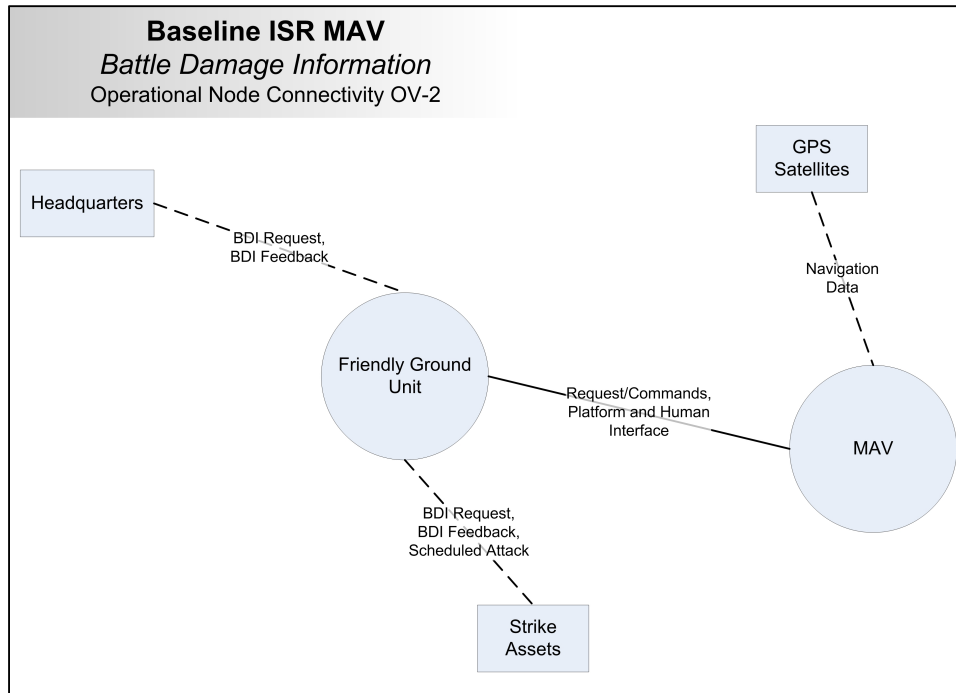

Figure 4.6 OV-2 for the Battle Damage Information Scenario

Local Area Defense OV-2: Figure 4.7 is based on the local area defense scenario. Again, from this scenario similar internal and external operational nodes and needlines were picked out based on the same logic as in the preceding two scenarios. Unlike the previous scenarios the need for *Strike Assets* was not identified. The only other distinct difference is that the previously discussed *Headquarters* node was identified as *Local Commander / Headquarters* which consists of the *Friendly Ground Units* commanding officer or higher headquarters which will receive enemy ground positions once collected.

Scenario Consolidation OV-2: The consolidated OV-2 takes all nodes and needlines from the three scenarios and compiles them such that all scenarios map to a single OV-2. Figure 4.8 shows the result of the consolidation. Two internal nodes represent the ground aspect of the system (*Friendly Ground Unit*) as well as the airborne part (*MAV*). A total of three external nodes are identified in the scenarios and are reflected in this consolidation: (*Headquarters*, *Strike Assets*, and *GPS Satellites*). However, one external node was not identified in the scenarios (*Maintenance Depot*) and was added after the OV-

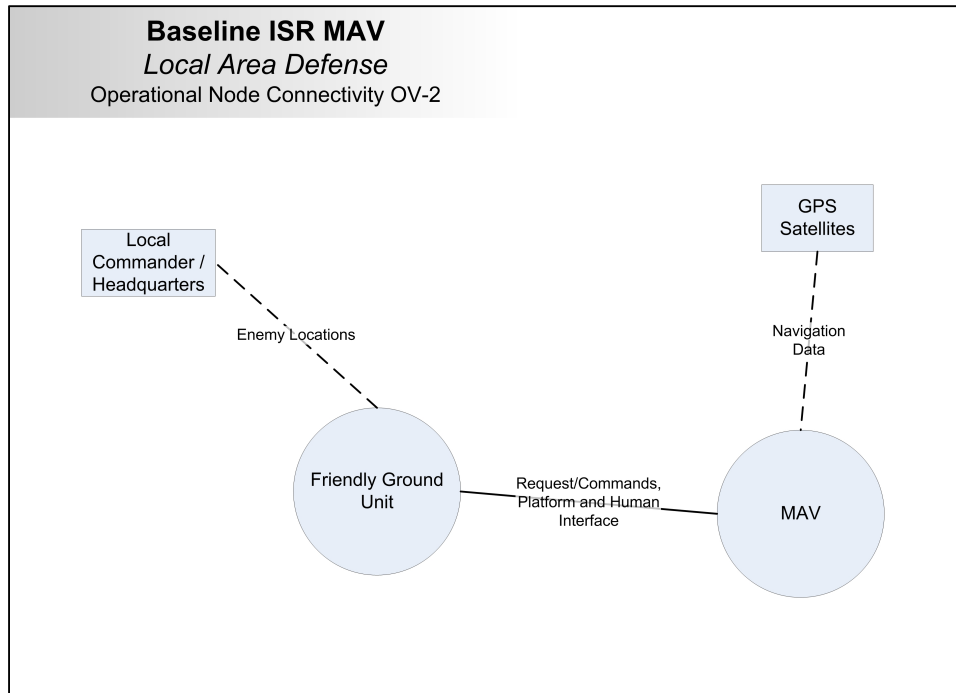

Figure 4.7 OV-2 for the Local Area Defense Scenario

5 operational activity model identified a need for external or non-field level maintenance. This new node handles all maintenance that can not be performed by the operator in the field.

The different needlines have been compiled into generally named needlines. For example, all needlines shown between the *Friendly Ground Unit or Special Ops Unit* and *Strike Assets* have been compiled into *Communicate with Local Strike Assets*. With the addition of the *Maintenance Depot* external node a new needline not shown in the scenarios was drawn to the *Friendly Ground Unit*. This needline, labeled *System Maintenance Needed/Requested*, covers the operator requesting maintenance that cannot be performed in the field and the maintenance personnel acknowledging when the system has been repaired.

Throughout the rest of the architecture development (from here forward) all products are based on the consolidated mission areas. The capability of the MAV in three mission areas will be collectively described as an ISR MAV.

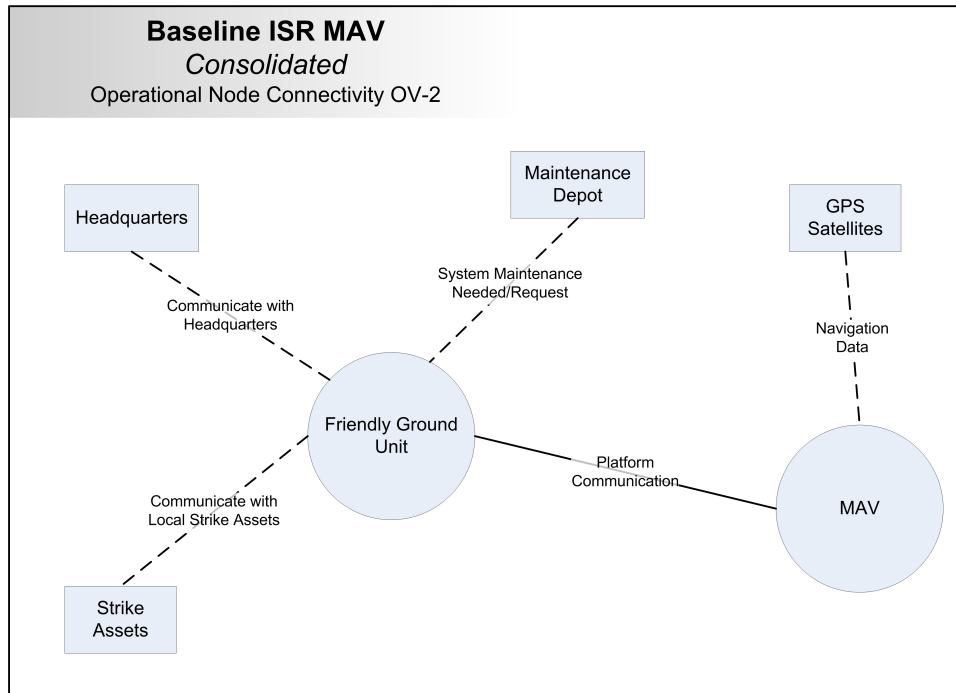

Figure 4.8 Consolidated OV-2 (reflecting all scenarios)

4.3.5 *OV-3 Operational Information Exchange Matrix.* The OV-3 Operational Information Exchange Matrix aids in the integration and definition of information exchanges throughout all operational view products. Essentially, it identifies who is involved, why the information is necessary, and how it is exchanged. Another way to look at this product is that it takes information elements, needlines, nodes, activities, and events from other operational views as well as their corresponding AV-2 dictionaries and correlates them into a matrix. Due to this integration there is no need for an AV-2 to be produced for this view for it would be redundant to the matrix.

As mentioned in Section 3.2.3, the OV-3 matrix, as with any defined matrix, is a set of rows and columns where their intersections contain information. The rows contain all information contained within a particular information exchange. The columns show specific information based on the columns heading. Due to the scope and goal of this research only certain columns will contain data; those shaded columns (i.e. blank columns) have been left for anyone who wishes to expand on this research (i.e. if applied to

a specific application). For particular information regarding the rows or column headings and their contents, refer to the OV-3 matrix figures located within Appendix F (total of 5 figures).

4.3.6 *OV-4 Organization Relationships Chart.* This product illustrates the command structure or relationships among human roles, organizations, or organization types that are the key players in an architecture [24:4-27]. Figure 4.9 represents the ideal steady-state use and interaction of the organizations required to produce an ISR MAV capability. This is how a generic ISR MAV organizational relationship could look.

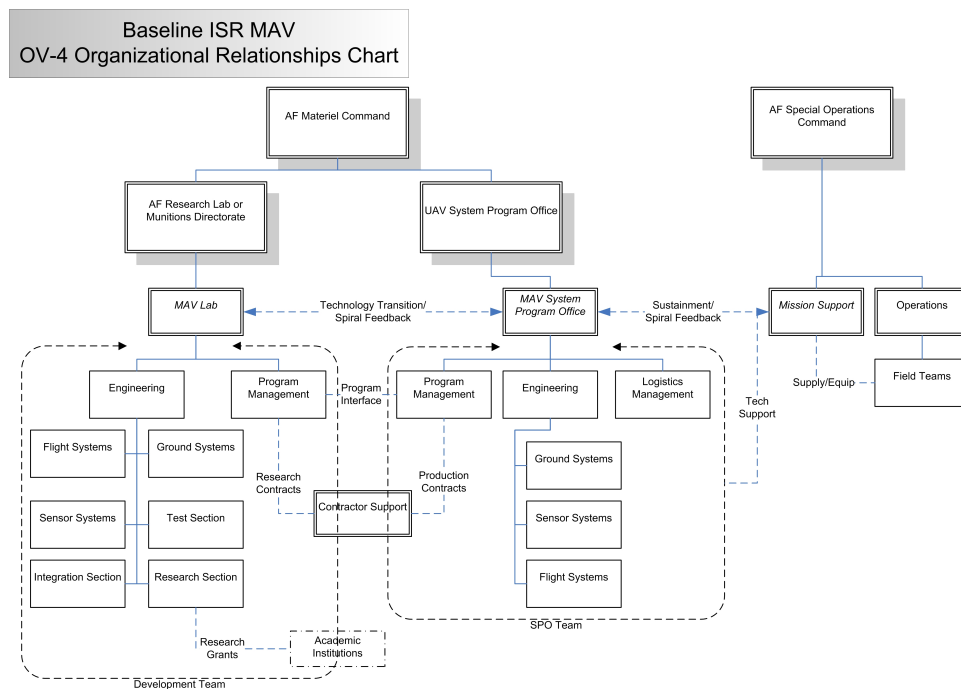

Figure 4.9 OV-4 Organizational Relationships Chart

Many influences come to bear on how organizations actually are formed and work: existing organizational structure, politics, command influence, applications of various organizational theory, etc. This OV-4 was designed on an ideal concept of functional organizations and their logical interaction with one another in an acquisitions and logistics environment. In cases of rapid spiral development, working groups and contingency operations, this ideal could be changed dramatically.

The ISR MAV OV-4 shows the three main communities that interact - the developers, the sustainers and the operators. These are shown as the MAV Lab, the MAV System Program Office (SPO), and the branches of the Special Operations community respectively.

Other than the two main commands (AF Materiel Command and AF Special Operations Command), the rest of the organizations and human roles are generically represented (or named). This was done to allow the architecture to be extensible; able to be tailored to specific purposes of the generic ISR MAV.

The MAV Lab is responsible for transitioning the technology to the MAV SPO and, in return, the MAV SPO provides feedback and direction towards future spiral designs of the MAV. The MAV SPO is then responsible to the operator community to sustain the MAVs, and in return the operators will provide feedback to the SPO on issues they are having with the current MAV as well as relay capability requirements.

The MAV Lab and the MAV SPO have similar setups due to the fact that many of the same technical and program related functions must occur in both development and sustainment. In development, the organizations are dedicated to integration, test and research. However, in the SPO where the system is relatively stable, an organization for logistics management is needed. It is likely, though not required, that contractor support provided for the development of the ISR MAV plays an important role in the production contracts as well.

In this construct of the steady state MAV organization, the Special Forces teams may not interface directly with the SPO for support. They will work through their mission support function within their command, who would then work with the SPO on and technical/support issues.

4.3.7 OV-5 Operational Activity Model. The Operational Activity Model (OV-5) is a functional decomposition of the system tasks consisting of inputs, controls, outputs and mechanisms (ICOM). Figure 4.10 is the *A minus One*, or external systems diagram

which sets the stage for how the system interacts with its environment as well as where

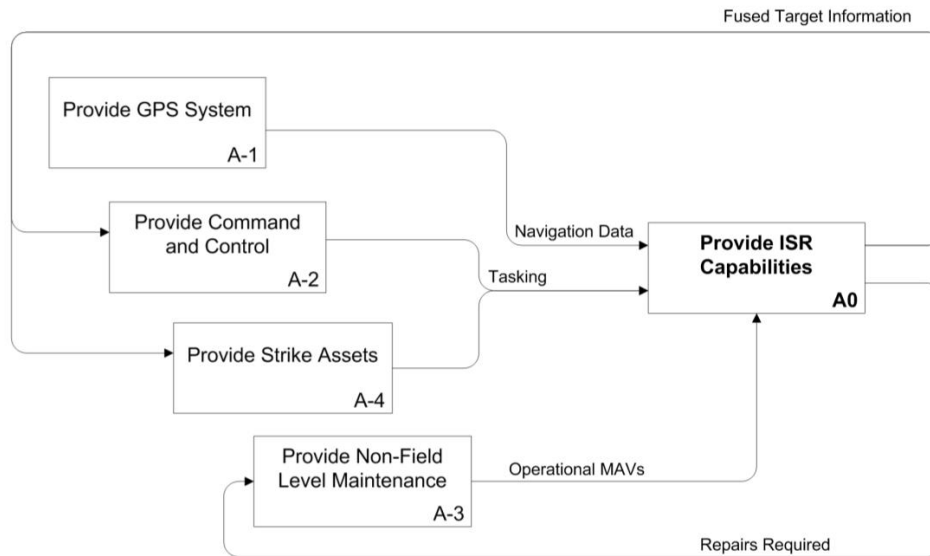

Figure 4.10 OV-5 External Systems Diagram

the system receives and sends information. The primary function of the system is to *Provide ISR Capabilities* as shown in box A0. The system requires a *Tasking* from either headquarters/local commander or a strike asset. To accomplish this mission, the system requires *Operational MAVs* from the maintenance depot and the *Navigation Data* provided by the GPS satellites. Using these elements, the system performs its mission and provides *Fused Target Information* as an output to the command and control infrastructure or the local strike assets. The last line is *Repairs Required*. External system repairs are necessary only if something inside the system boundary cannot be repaired in the field.

Next in the decomposition (Figure 4.11) is the *A minus Zero* or context diagram. This shows all inputs, outputs, controls and mechanisms (ICOM) for the system. The system inputs and outputs were discussed previously, but we have new information regarding the mechanisms and controls for the system. *Flight rules or Airspace Deconfliction* consists of any external influences such as weather, local radio traffic, proximity to other operating units, etc that have an influence on how or when the MAV is used. *Mission Operating Procedures* are any other limitations or guidelines imposed by



Figure 4.11 OV-5 Context Diagram

the particular mission type. As for the mechanisms, the MAV system requires *operational MAVs*, *the ground station* and the *human operator*. The parenthesis around the head of the arrow in the diagram represents that this line is going to be tunneled and will not appear in subsequent decompositions.

The primary system decomposition, shown in Figure 4.12, is the first diagram breaking down the particular aspects of how the system will do its job. Shown here are the inputs and outputs previously discussed, as well as the five primary functions of the MAV system: *Provides Information Processing*, *Enable Launch MAV*, *Provides ISR MAV Platform*, *Enable Launch/Recover MAV* and *Provide Field Level Maintenance*. The decompositions for these components follow the A0 diagram. Full descriptions for each data block and flow line can be found in the AV2 Integrated Dictionary for the OV5 in Appendix H.

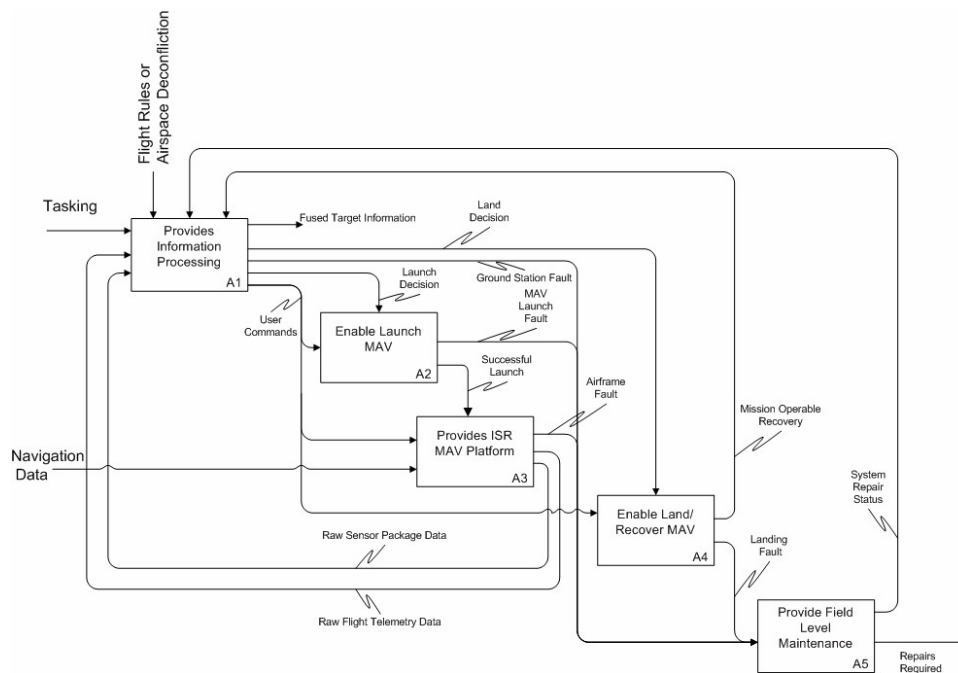

Figure 4.12 OV-5 Level A0

4.3.8 *OV-6C Operational Event Trace Description.* This architectural product shows a time-ordered view of the actions occurring within the operational nodes of the system based on a given scenario. This scenario serves as the operational event trace description and guides the development of the operational event trace diagram.

Operational Scenario (Operational Event Trace Description) The entry condition to this consolidated scenario, shown in Figure 4.13, starts with a mission being directed or already in progress [mission directed, 1.1]. A friendly team member decides to utilize the MAV system to obtain ISR info (decision to launch, 1.2). The MAV is at hand and is launched after its prep time (system initialized, 1.5, GPS synch implied, 1.4, 1.3, MAV ready for launch, 1.6, launch MAV, 1.7). The MAV performs the mission programmed into it during system initialization (perform mission profile, 1.9). The operator can also update the mission profile or fly it manually (update mission profile, 1.8). The operator observes the sensor feedback from the MAV and reacts accordingly (collect sensor info, 1.12, transmit sensor info, 1.16, receive sensor info, 1.11, process info, 1.14, additional mission profile updates, 1.8). If required or necessary, the collected

ISR info from the MAV may be relayed to a local commander/headquarters or to strike

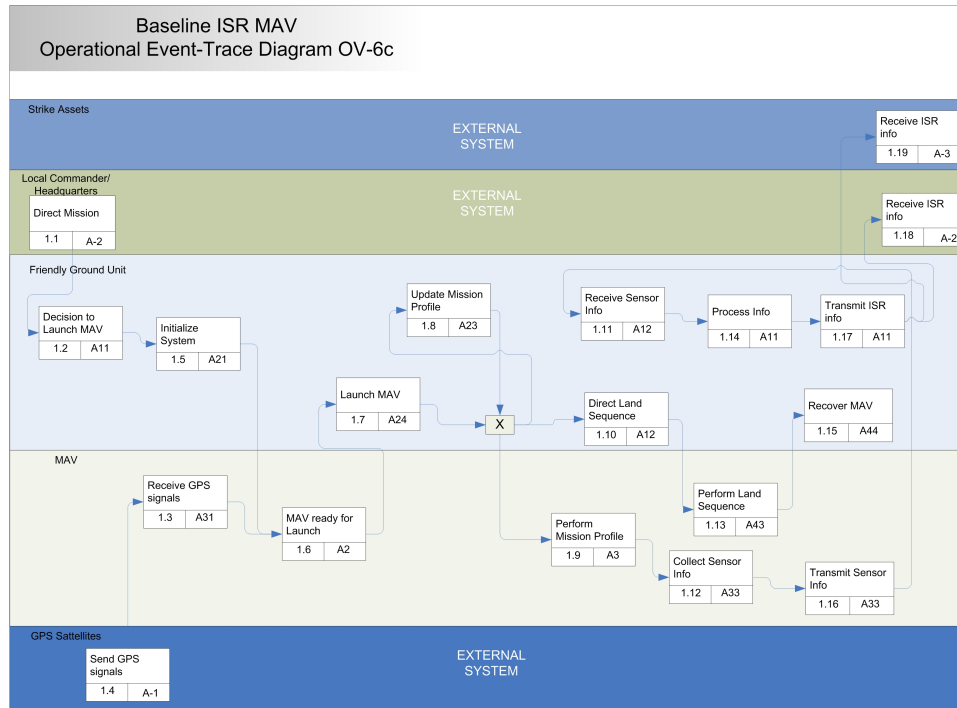

Figure 4.13 OV-6c Operational Event Trace Description

assets (transmit ISR info, 1.17, receive ISR info, 1.18, 1.19). The decision to relay this information is left to the operator. Once sufficient ISR information is obtained or the MAV has reached its limits, the operator can either return the MAV to the base (direct land sequence, 1.10, perform land sequence, 1.13, recover MAV, 1.15) or choose to continue loitering the MAV until complete power failure; expending the MAV.

Using this scenario, all units of behavior (or actions) were assigned to the responsible operational nodes (or swimlanes) and sequencing was added to the diagram. The references to these actions were then added back into the operational event trace description. This way the diagram and description are linked and can be used together to fully represent the scenario.

The flow through the operational event trace diagram is relatively straight forward. The one alternate path junction, seen in the middle of the diagram, represents the ability to command the MAV with either new mission profiles, to land, or allow it to perform its

mission as previously programmed. It should be noted that this diagram is only a time-ordered representation of the scenario. It only shows what actions are temporally linked and dependent upon each other.

4.3.9 *OV-7 Logical Data Model.* The logical data model defines the data domain for a given architecture. Instrumental in creating this model is having access to a completed operational activity model. The ICOMs from the OV-5 are commonly used to define data entities or are attributes within another data entity.

The MAV system data model shown in Figure 4.14 revolves around sensor information, telemetry information, and commands. Additionally, the system requires

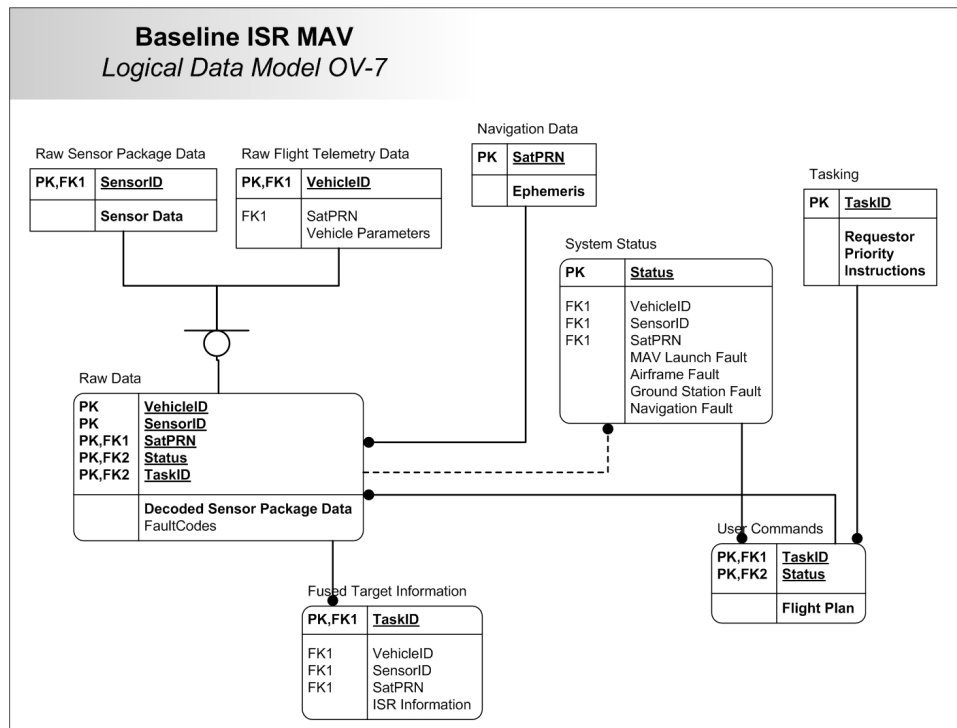

Figure 4.14 OV-7 Logical Data Model

GPS satellite lock during all portions of the flight profile for normal operation, however, in the case that GPS becomes or is not available the system can be manually guided through the *User Commands* entity. A *status* entity is used to capture the various faults that may occur while using the MAV system.

Before issuing commands to the air vehicle, a *Tasking* must exist, and the system status must be fault free. During system use, the status is continually updated to provide the operator indications of possible problems. Information sent from the air vehicle is comprised of *raw sensor package data* and *raw flight telemetry data*. These two distinct pieces are connected to their parent entity known as *Raw Data* which in turn feeds into the *Fused Target Information* entity to produce ISR information.

The view provided by this Logical Data Model is somewhat abstract allowing the disciplined engineers the flexibility to tailor the entities, either by adding, subtracting or altering the keys, attributes, or relationships contained within the data model.

4.3.10 SV-1 Systems Interface Description. This product depicts system nodes, the systems residing in those system nodes, and the functions performed by those residing systems. Also identified here are the interfaces between systems.

In order to show the proper amount of detail for an initial baseline architecture, this research concentrates on the two more detailed versions of the possible four SV-1 versions identified in section 3.2.3. The versions completed were the SV-1b; *internodal* depiction of system-to-system interfaces, and the SV-1c; *intranodal* depiction of system-to-system interfaces. Both the SV-1b and the SV-1c views include the functions performed by each system (with the exception of external systems). The remainder of this section presents these diagrams and their supporting textual descriptions.

Creation of the SV-1b started with the consolidated OV-2 operational node connectivity diagram (Figure 4.8), where operational nodes became system nodes (shaded circles) and external nodes became external systems (shaded rectangles outside of the nodes). The OV-2 diagram establishes the need to communicate between nodes, otherwise known as needlines. These needlines are used to establish one or more system interfaces in the SV-1b which are depicted as internal interfaces (solid lines) or external interfaces (dashed lines). For example, the *Platform Communication* needline becomes *Platform Interface* and *Request/Commands, ISR Data* interfaces. Interfaces within the SV-1b

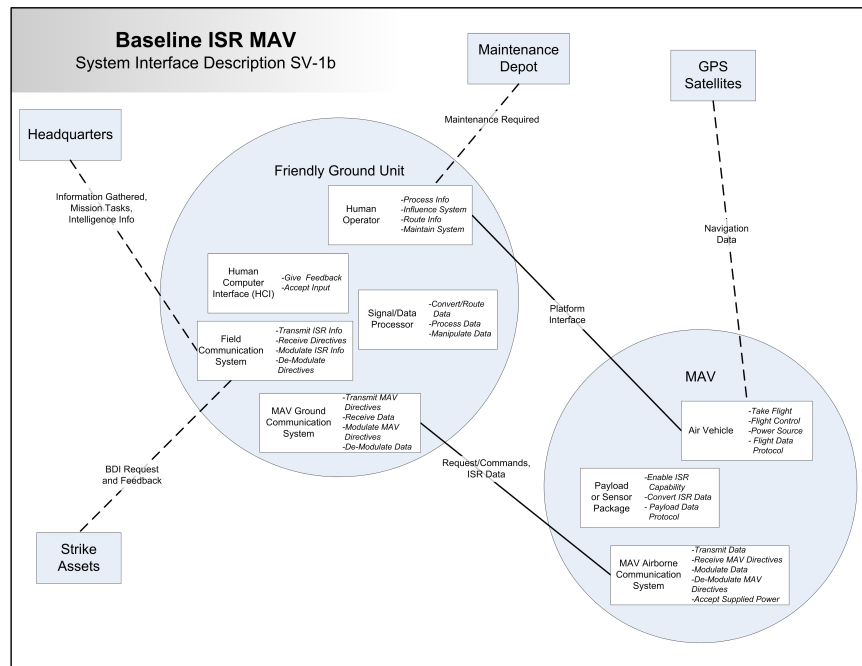

Figure 4.15 SV-1b System-System Interfaces

also correspond to the needline definitions in the OV-2, however, note that the *Platform Communication* needline was separated into two interfaces. The *Platform Interface* involves any direct contact between the *Human Operator* and *Air Vehicle* systems while the *Request/Commands, ISR Data* interface includes any communication between the two system nodes.

The remaining two diagrams are the intranodal versions shown in Figures 4.16 and 4.17 for both the *Friendly Ground Unit* and *MAV* system nodes. Although the diagrams are similar to the SV-1b, the SV-1c shows the interfaces within the system nodes. Since each interface is defined in the AV-2 dictionary and its purpose is hinted at in the diagrams above, they will not be described here. The only clarification that will need to be made is that of the power situation in both system nodes.

Notice in the *MAV* system node (Figure 4.17) that power is depicted as an interface; however, in the *Friendly Ground Unit* node (Figure 4.16) it is not. This is due to the power (and weight) limitations imposed by the *Air Vehicle* system. To ensure that the

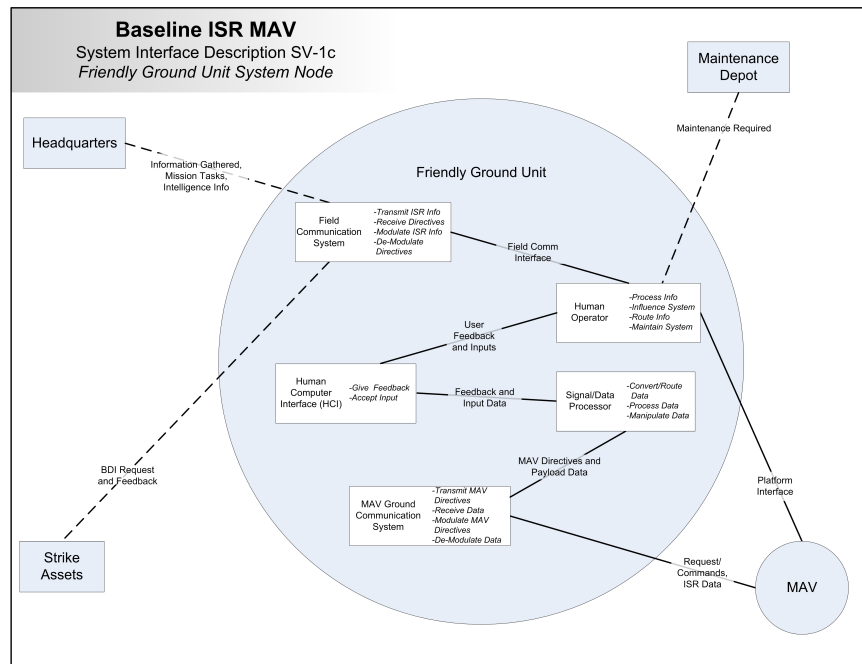

Figure 4.16 SV-1c Intranodal Version of the *Friendly Ground Unit*

Air Vehicle can provide flight all systems within the *MAV* node need to utilize the power already provided. If the *Air Vehicle* cannot provide the power needed then the system will either be required to find some means to require less power or sacrifice some of its weight allocation in order to have an internal power supply. Ideally both the *Payload or Sensor Package* and *MAV Airborne Communication System* would use the provided power supply such that design (or functional) tradeoffs would not have to be made (i.e. the power supply would take up weight allocation normally allocated by functions). Of course if these system resident to the *MAV* node do not require power provided by the *Air Vehicle* then this link would not exist. This problem is not addressed within the *Friendly Ground Unit* because the weight limitations are a little more relaxed and current hardware systems being used already come with their own power source. Power will only appear if the systems within the *Friendly Ground Unit* are decomposed into subsystems.

Based on Figure 4.16, a total of five systems exist within the *Friendly Ground Unit* system node and are depicted as non-shaded rectangles: field communication system, human-computer interface (HCI), Human Operator, MAV Ground Communi-

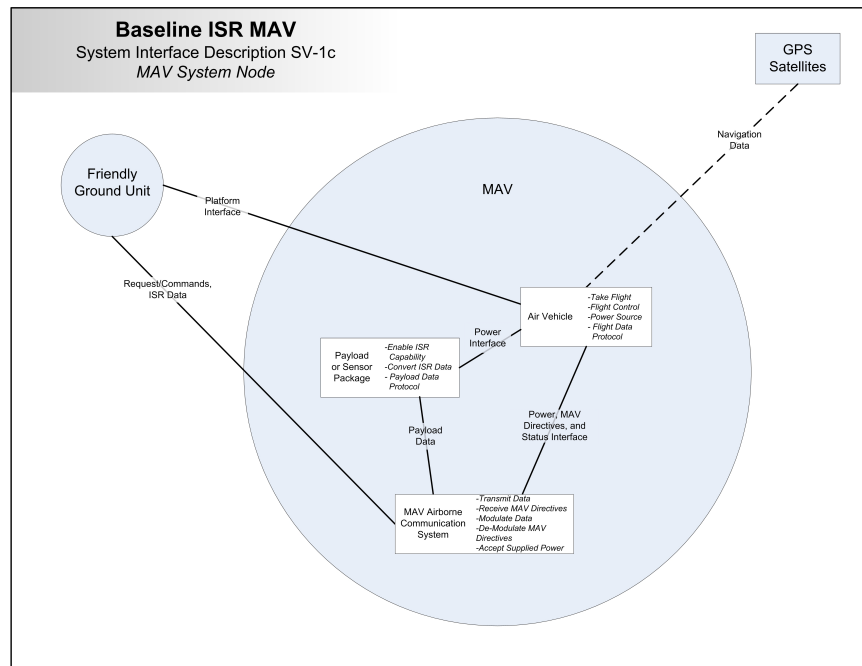

Figure 4.17 SV-1c Intranodal Version of the MAV

cation System, and Signal/Data Processor. Each system includes a set of functions, where the system functions define what the system is responsible for. These system functions are located to the right of the system name in a smaller, italicized font.

The field communication system allows the *Human Operator* to communicate gathered ISR information and mission directives with higher *Headquarters* or *Strike Assets*. Examples of such systems include satellite communication radios or a general purpose field radio. The Human-Computer Interface includes those items that give feedback (display, speakers) to the *Human Operator* as well as those that allow users to supply input to the system (keyboard, mouse, touch screen, microphone). The *Human Operator* is a model of the operator's role in the system. The operator either affects the system through direct contact (*Platform Interface* and *Field Communication Interface*), through the *HCI* system (*User Feedback* and *Inputs Interface*), or through the request of outside maintenance to the *Maintenance Depot* system. The *MAV Ground Communication System* allows all systems within the *friendly ground unit* to communicate directives with the airborne systems in the *MAV* by ensuring that data can be sent to and received from the

MAV Airborne Communication System. Examples of such hardware equipment include transmitters, receivers and antennas. The *Signal/Data Processor* system processes, converts, and manipulates data such that the proper data packets can be delivered to the *HCI* and the *MAV Ground Communication System*.

The *MAV* system node, shown in Figure 4.17, contains three systems that enable the collection and transmission of ISR data. These systems are also depicted with non-shaded rectangles within the system node and the system functions are to the right of the system name.

The *Air Vehicle* allows other systems within the *MAV* to operate as airborne systems. Examples of hardware systems that could perform the system functions are an aircraft fuselage with wings, autopilot, and propulsion system. The *MAV Airborne Communication System* allows airborne systems within the *MAV* to communicate gathered data, directives, and status information with the ground systems *Friendly Ground Unit* by ensuring that data can be sent to and received from the *MAV Ground Communication System*. Examples of such hardware equipment include transmitters, receivers and antennas. The purpose of the *Payload or Sensor Package* system is to collect and provide the needed ISR information by utilizing the power source supplied by the *Air Vehicle* system. Once the ISR information is obtained, it is sent to the *MAV Airborne Communication System* for transmission.

4.3.11 SV-4 Systems Functionality Description. The SV-4 shows the functional hierarchies and system functions of the ISR MAV. Similar to the OV-5, this product decomposes the top-level functions and shows their relationships and data exchanges. This product takes the functions listed in the systems of the SV-1 and shows their inter-relationships. The data exchanges are more detailed and are described fully in the SV-6. While the OV-5 looked at all operational activities of the system, the SV-4 is a data-focused product; hence the activity of non-field level maintenance was not included.

The system functional decomposition is shown in Figure 4.18. The primary function of *Providing ISR Capabilities* is at the top and is sub-divided into its subsystem functions

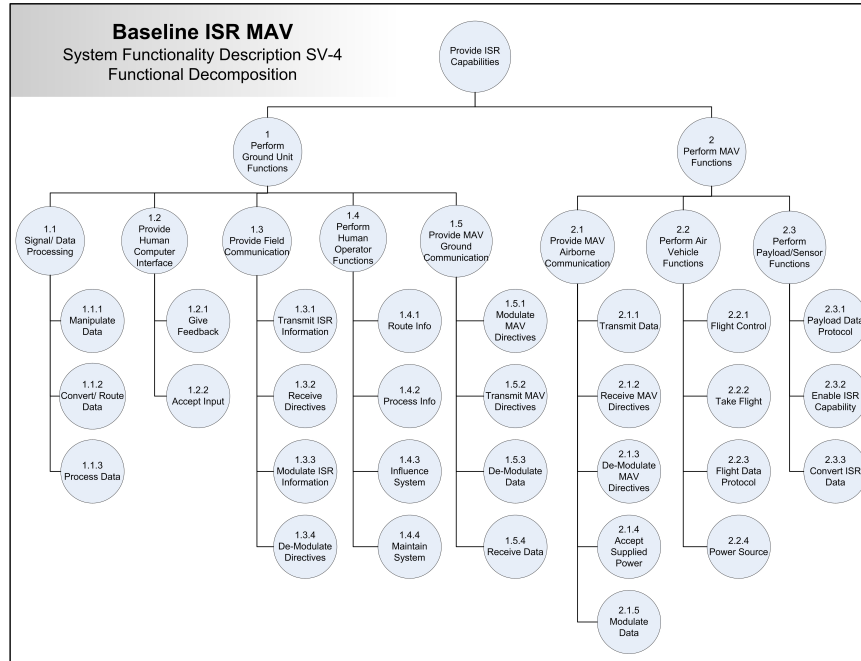

Figure 4.18 SV-4 Functional Decomposition

Perform Ground Unit Functions and *Perform MAV Functions*. From here, the functions continue to be decomposed until they reach a level that could be assigned to component-level design. The following views will show more of the interaction between the sub functions.

Figure 4.19 shows the top-level interaction of the functions of the system. At this level of detail, the functions, external systems and data exchanges look very similar to products in the operational view. That is because at this level, all of the major nodes and interactions are the same. The true benefits of this product come at the lower levels of decomposition where specific data exchanges and subfunctions begin to form the physical system.

The *0-Level Diagram* is decomposed further into levels 1 and 2. Level 1 shows the break-out of the first major sub-function, *Perform Ground Unit Functions*. At this level,

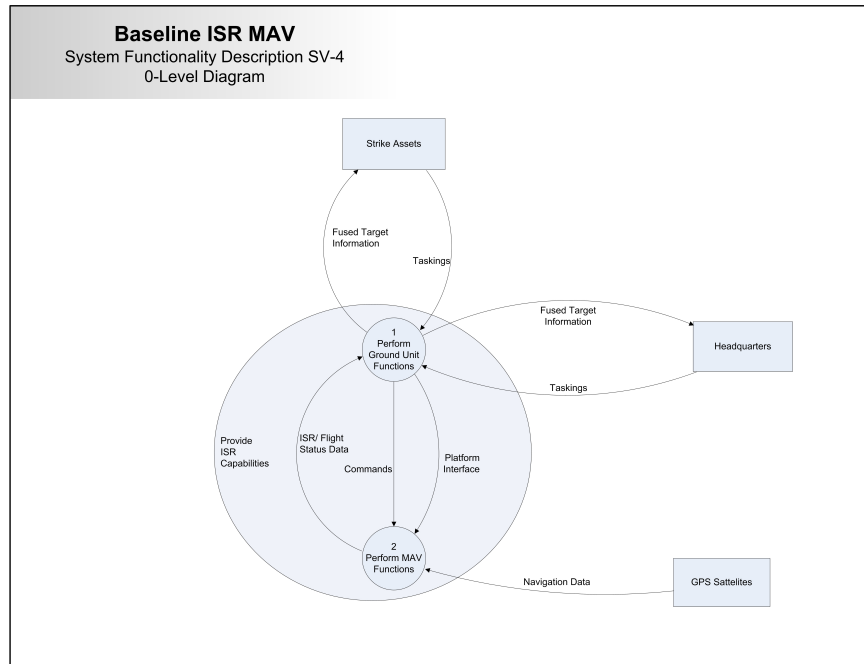

Figure 4.19 SV-4, 0-Level Diagram

many of the functions and interactions are similar to the SV-1c. Level 2 provides the break-out of the second major sub-function, *Perform MAV Functions*. The complete set of functional decomposition diagrams are found in Appendix K. In each diagram, one will see how the sub-functions interact and the data exchanges are assigned.

4.3.12 SV-5 Operational Activity to Systems Function Traceability Matrix. The SV-5 (Figure 4.20 and 4.21) demonstrates the relationship between operational activities and system functions to ensure the architecture has traceability (reference Section 3.2.3). The relationship is rated on support status of the functionality and whether or not the

System		Capability to perform Recon, BDI, and LAD													
		Information Processing		Launch MAV				ISR MAV Platform			Recover MAV			Provide Field Level Maintenance	
		Process Information	Provides Vehicle Control and Communication	Initialize MAV	Calibrate MAV	Upload Mission Profile	Launch MAV	Provides Flight Controls	Provides Flight Vehicle	Enables Sensor Package	Calculate Flight Plan to Landing Zone	Fly to Landing Zone	Perform Landing Sequence		Recover MAV
System Function	Op Activity														
Human Operator	Process Info														
	Influence System														
	Route Info														
	Maintain System														
Field Communication System	Transmit ISR Information														
	Receive Directives														
	Modulate ISR Information														
	De-Modulate Directives														
Human Computer Interface	Give Feedback														
	Accept Input														
Signal/Data Processor	Convert/Route Data														
	Process Data														
	Manipulate Data														
MAV Ground Communication System	Transmit MAV Directives														
	Receive Data														
	Modulate MAV Directives														
	De-Modulate Data														

Figure 4.20 SV-5 page 1

system is fielded. The degree to which a system supports the functionality is defined by the numerical status code. These status codes are numbered one to three and where there is no code, a relationship does not exist or is not planned. A status code of one implies full functionality is provided and the system is fielded. A status of two means the function is partially provided or fully provided but the system has not yet been fielded. A status code

of three means functionality is planned but not developed. Status codes were not produced

System		Capability to perform Recon, BDI, and LAD													
		Information Processing		Launch MAV				ISR MAV Platform			Recover MAV				Provide Field Level Maintenance
		Process Information	Provides Vehicle Control and Communication	Initialize MAV	Calibrate MAV	Upload Mission Profile	Launch MAV	Provides Flight Controls	Provides Flight Vehicle	Enables Sensor Package	Calculate Flight Plan to Landing Zone	Fly to Landing Zone	Perform Landing Sequence	Recover MAV	
Op Activity	System Function														
Air Vehicle	Take Flight														
	Flight Control														
	Power Source														
	Flight Data Protocol														
Payload or Sensor Package	Enable ISR Capability														
	Convert ISR Data														
	Payload Data Protocol														
MAV Airborne Communication System	Transmit Data														
	Receive MAV Directives														
	Modulate Data														
	Accept Supplied Power														
	De-Modulate MAV Directives														

Figure 4.21 SV-5 page 2

in this research since this is a baseline architecture intended for generic application; however, the relationships between the operational activities and system functions are identified. The SV-5 matrices show systems and their system functions related to the operational activities within a capability and then to the mission capability (in this case the capability to perform reconnaissance, battle damage information, and local area defense was used). When this matrix is applied to a particular application, the status codes can be filled in. This identifies stovepiped systems, redundant/duplicate systems, gaps in capability, and possible future investment strategies [24].

The systems and system functions used in the SV-5 matrix are pulled from the SV-1 systems interface description diagrams while the operational activities and capabilities are from the OV-5 operational activity model. Not all operational activities are used, only those lowest level activities are included because, if the low level activity relates

to a system function, then so does its parent. Essentially, the capabilities are the first level activities shown in the OV-5. This helps to break down the mission capability while grouping the activities. Both Figures 4.20 and 4.21 are of the SV-5 traceability matrices produced for the baseline architecture.

4.3.13 SV-6 Systems Data Exchange Matrix. The SV-6 Systems Data Exchange Matrix aids in the integration and definition of system interfaces throughout all system views. It defines and integrates the system functions involved, data containing elements, and how data on the interface is exchanged. Normally, this architectural product contains only automated interfaces, meaning those interfaces that represent machine interaction. Most of the interfaces within the system views of this research follow this principle; however, there are four that are considered non-automated. These non-automated links are included because this is an initial baseline architecture where clarity is essential. These non-automated interfaces all connect to the *Human Operator* system and are: *Platform Interface*, *Field Comm Interface*, *User Feedback and Inputs*, and *Maintenance Required*.

Just as in the OV-3 operational information exchange matrix, the SV-6 is a matrix with a set of rows and columns where their intersections contain interface information. The rows contain all information contained within a particular interface exchange. Since the relationship between system interfaces and system data exchanges are one-to-many they are categorized first by the system interface name shown in all versions of the SV-1 and then by the system data exchange name which can be SV-6 unique but, in this case, correlates to the OV-3's information exchange names. The columns show specific information based on the column heading. Due to the scope and goal of this research only certain columns contain data; those shaded columns are left blank for anyone who wishes to expand on this research (i.e. if applied to a specific application). For particular information regarding the rows or column headings and their contents, refer to the SV-6 matrix figures located within Appendix N (total of 7 figures).

4.4 DOTMLPF Considerations

All of the architectural views presented previously refer to the operation of a material system. Other areas of the ISR MAV system's operation need consideration as well. In the Joint Capabilities Integration and Development System (JCIDS), much emphasis is given to addressing capability impacts in the areas of doctrine, organization, training, materiel, leadership and education, personnel, and facilities (DOTMLPF). These areas are considered to be outside of the systems physical boundaries; however, they play a crucial role in the actual capability achieved. As this system architecture is already a materiel solution to the capability gap identified in Chapter II, this DOTMLPF discussion will omit the material discussion and assumes it as a given.

4.4.1 Doctrine. The ISR MAV may have a long term impact on the doctrine of the ISR community; however, in the near future, the ISR MAV represents another tool for the special operations forces. The SOF teams will still be employed and be assigned to missions in the same manner in which they normally are, but the ISR MAV is a new tool that will enhance their mission effectiveness. Since there is no fundamental change to the user's core tasks, the ISR MAV is not likely to affect doctrine in the near future.

4.4.2 Organization. Organizational impacts may occur in two different levels: tactical and developmental/sustainment. The changes to the tactical level would be the decision to make the ISR a dedicated position on the deploying teams, or have every member become ISR MAV capable. This could lead to ISR MAV specialization within teams. Then future variants of the MAV would fall that member, however the use of the MAV would be person dependant. If every member of the team is ISR MAV capable (trained and equipped) then its use would become more available. This method would require more assets and likely more repairs due to storage and transport, but it would make the capability more available when needed.

The other organizational change would require the formation of (if one is not already present) and development of relationships between a development organization and a

sustainment organization to handle the ISR MAV. Architectural view OV-4 shows a likely steady-state view of such organizational relationships.

4.4.3 Training. Training on the ISR MAV system is necessary in order to operate it successfully. While many varieties of training delivery can be imagined (classroom, field, virtual, verbal, written, on-job-training (OJT), etc.) the top-level original requirement of *operable by trained personnel* remains.

There are essentially two major systems that an operator must become trained on and familiar with to operate the system: the ground station, and the MAV. The MAV is a largely electro-mechanical system and so the operator would need to be trained in initialization (power on) of the MAV, launch procedures, minor parts-replacement repairs, recovery of the MAV and storage/transport of the MAV. The ground station is largely a hardware/software unit and so the operator would need to be trained in initialization of the system and software program, software navigation, basic/intermediary/advanced operation of the system through the software program, and storage/transport of the system. Both systems, as a collective, would require a user to have a basic level of training that would enable them to initialize the system, program a simple flight plan, launch and recover the system, and simple manipulation of the data. An intermediate level of training would include operations such as advanced flight planning, manual flight control, and advanced data manipulation. The advanced level of training would allow the operator to manipulate limits on system parameters such as air speed, bank angles, and manual commands in order to perform complicated flight patterns.

A classroom or virtual environment could handle an introduction of the system and most of the software operation. Through use of a training software program, the trainee could virtually fly an MAV through the required training flight programs for certification. However, due to the flight aspects of the system, a field or OJT training environment would be preferable. In this method of delivery, the trainee will have instant feedback of their operating skills. In the field or on a range, the trainee could also simultaneously be trained

on MAV launch, recovery, storage and transport of the system, and all the other aspects of the system that make it unique.

4.4.4 Leadership and Education. Leadership and education would be impacted in the long term for the ISR MAV. The system would now enable Special Forces to have a larger local area situational awareness. Leaders would need to realize this and it may affect how they employ the teams that have the ISR MAV verses those that do not. The ISR MAV capability will influence the decisions that can be made in each mission. When planning for and employing the special forces required for each mission, the ability to see real-time their surrounding beyond line of sight will give them an advantage over adversaries that only assume line of sight capabilities when no larger aircraft are available. Employment of forces to areas of unknown conditions may increase since they would now have independent real-time intelligence gathering assets. Before, teams were limited by their access to intel gathering assets at the local command level rather than at the team level itself.

Education of the team, unit, and command leaders will also need to include this new tactical capability. In much the same way that leaders are aware of the capability that a sniper or a machine gunner brings to a small tactical team, the awareness of the ability to see beyond the line of sight would need to be instilled in the emerging leaders of the Special Forces functional area.

4.4.5 Personnel. Personnel changes would be dependent on the manner in which the ISR MAV is to be employed. If the capability is to be assigned to one member of a tactical team then there is the possibility of a specialty code emerging for the operation of MAVs (much like a sniper, machine gunner, etc.). The rest of the team would still be required to be minimally trained on the system in case of contingencies. If, however, the intent is for every member of a tactical team to have the ISR MAV capability, then personnel impacts would be minimal. It would simply be considered another part of their tactical training skill set.

4.4.6 Facilities. Facilities for the ISR MAV would be minimal. They would be largely dependant on how their development, sustainment and logistics are managed. If their development is absorbed by existing developmental organizations, then the facilities would already be handled. The same would apply for a sustainment organization (dedicated or basket SPO). Parts for the ISR MAV would need to be housed in various locations. War ready reserves would need to be housed in theater for quick access and use. Excessive stockpiles of parts are not envisioned as part of the logistics planning, and so warehouse storage beyond normal programmed supply limits would not be needed. The production contractor (if a Contractor Logistics Support (CLS) contract is used), the depot repair facility, or the Defense Logistics Agency (DLA) would absorb the necessary parts to maintain the ISR MAV.

4.5 Future Capabilities and Technologies

4.5.1 Future Capability Discussion. The MAV concept has the potential to provide many other mission capabilities outside of those discussed thus far. This section concentrates on these future mission capabilities and how they influence the baseline architecture produced in this thesis. These capabilities are grouped into three categories based on implementation timeline. Short-term is considered within the next five years. Mid-term is between five to ten years and long-term is greater than ten years. This is a general timeline in which user needs and technological development will effect which capabilities will be pursued as well as when they will become available. Some of these capabilities are already available in other larger UAVs or manned platforms; however, further technological improvements must occur for the capabilities to meet the unique payload requirements of the MAV.

These possible future mission capabilities are outlined in Figure 4.22. These future capabilities and their descriptions are based on general user need trends, current manned platform capabilities, and the DoD's *UAV Roadmap 2002* [12]. Listed below are the general descriptions of each future capability. The ISR MAV architecture was reviewed

for applicability of each of the proposed future capabilities and changes required are noted. Most of these future capabilities only require wording changes for the architecture data links, information exchanges, and needlines. If these future capabilities are pursued, the baseline architecture products need to be more in depth and the lower system levels and associated data descriptions need to be refined for component-level design.

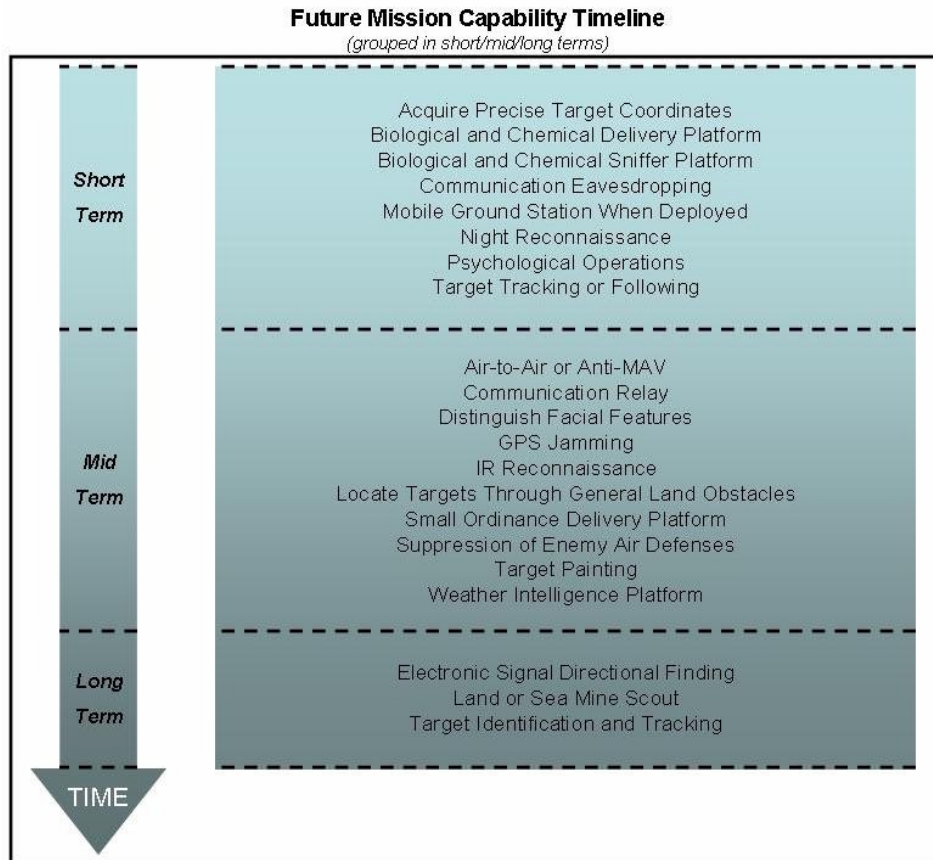

Figure 4.22 Future Mission Capability Timeline

Short Term Mission Capabilities:

1. Acquire Precise Target Coordinates

This capability enables the user to obtain more precise coordinates on a target using an MAV. Currently users can get a general idea of the targets location by observing the MAVs current position. This current method is not accurate enough for guided precision munitions or reliable target tracking. Implementation examples can include measuring the distance and angle of the target relative to the MAV and then performing calculations using the MAVs GPS position to determine the

targets location. If using GPS to acquire a targets location, the use of a dual band receiver is necessary in order to obtain the needed precision. The additional signal processing for coordinate generation is the primary requirement change for this capability. The extra signal processing can be handled by either the air platforms *Payload* or ground units *Signal/Data Processor*, therefore this capability will not require any baseline architectural changes.

2. **Biological and Chemical Sniffer Platform**

Giving an MAV the ability to detect harmful biological or chemical weapons will give ground units more time to prepare for protection or even enable the units to move to a safer location. Termed a *sniffer*, this biological or chemical detector could be attached as a payload or even refined to be apart of the air platform such that other payloads could still be attached. Since this capability could be considered a simple sensor, it would operate within the current ISR MAV architecture (where currently the image capture sensor is represented), therefore this capability will not require any baseline architectural changes. If it is packaged with the air platform however, a system will need to be added to the *MAV* operational and system nodes to reflect the added *sniffer* system.

3. **Communication Eavesdropping**

A MAV can be used to eavesdrop on enemy communications by either collecting transmitted signals (includes directionally transmitted signals), monitoring wired communications, or collecting voice conversations. The MAV can accomplish this capability acting as the collector deploying sensors, or both. This allows special operations units to operate at safe distances and in a more preferred location when conducting communications intelligence (COMINT). This capability can require baseline architectural changes depending on the employment method. In general, the COMINT system used can be included as apart of the *Payload* system.

4. **Mobile Ground Station When MAV Deployed**

Having the capability to relocate the ground station while the air platform is deployed is of great benefit to the user. Current architecture reflects only the MAV requiring external navigation information, if the ground unit also receives this information, it could be tied to a digital moving map based on where the ground unit is while also showing the MAVs location. This added capability enhances the ground unit's situational awareness and increases mission effectiveness. It will require more optimized systems (size, weight, power, etc.) be developed in order to support the mobile user; however, these systems and interfaces are already architected in the ISR MAV model. This capability requires little architectural changes, mainly the addition of an information exchange between the *Friendly Ground Unit* and *GPS Satellites* nodes.

5. **Night or IR Reconnaissance**

This capability acts as an improvement to the over-the-hill reconnaissance scenario in the sense that it enables the user to conduct reconnaissance at night or during periods of low light. Optimized night vision systems need to be developed to give the user the capability to conduct reconnaissance when they need it most. Since this capability is simply the inclusion of a different payload sensor, no architectural changes are necessary. The system interfaces and data links are already modeled.

6. **Psychological Operations**

The capability to perform psychological operations is a very broad capability and spans many different missions. Considered in this thesis is the ability to send a “message” to the enemy or non-combatants that another military force is present in the area and that they are being watched. Also considered is the ability to drop propaganda leaflets as well as to serving as an unknown weapon, meaning ground observers may be unaware of whether or not it is armed. This capability may require architectural changes depending on the psychological mission pursued. If only a message of *US forces present* is sought, the current ISR MAV capability can perform that mission in its current configuration. If the mission would require the delivery of leaflets or other objects, the architecture would need to include a payload release function and data elements that would transmit the release commands.

7. **Target Tracking or Following**

The capability for a MAV to accurately track or follow an assigned enemy target will keep the ground unit up-to-date on enemy movement and increase their situational awareness. This ability to track or follow a target should be automated so the user can continue with the mission and remain mobile (in a way ties to the *Mobile Ground Station When Deployed* capability). This capability focuses on tracking only one target, multiple target tracking is addressed in the *Target Identification and Tracking* capability. Signal processing and target movement detection systems would need to be greatly enhanced and refined to meet the payload size and demands. Assuming the enhanced processing and detection could be achieved, this capability would not require any baseline architectural changes. The processing and detection functions would be enabled by the existing signal processor, payload sensor, and respective data links.

Mid Term Mission Capabilities:

1. **Air-to-Air or Anti-MAV**

Historically, manned aircraft were utilized as reconnaissance platforms, transformed to ground attack units and then employed as air-to-air fighters. MAVs and UAVs have started the same trend as some UAVs are now seeing the air-to-ground attack role. The capability of air-to-air MAV or Anti-MAV enables force protection

against enemy MAV capabilities. This includes MAVs designed to attack other enemy MAVs (air-to-air) or simply ground units attacking enemy MAVs (surface-to-air). With the rise of MAV interest, the need for this capability is not far off. Technical issues such as how to quickly locate an enemy MAV, what kind of weapons would be the most effective, and what air-to-air tactics to use necessitates further exploration. This capability requires changes to the baseline architecture. The developed capability needs will determine the necessary changes. Some basic architecture changes that are foreseen already are the addition of a function to employ an attack mechanism against the enemy MAV and the associated data/command links to enable such a function; whether it is on the MAV or the ground system.

2. **Communication Relay**

This capability gives the user the ability to increase their communications range and, if properly implemented, can lower the probability of intercept and detection. One way to increase the range of a communications device is to send a MAV into the air to act as a network link which receives data from the ground unit then transmits it to the receiver. This enhances such communication systems that require line of sight or that experience degradation due or loss due to terrain. Technical issues such as how to give the MAV enough power to perform this mission need to be worked out. Another way to deploy a MAV as a communications relay is to relate it to a messenger bird such that the MAV stores the data to be communicated and is instructed where to go for transmission. This keeps the ground unit electronically concealed from the enemy because the MAV is flying to a safer broadcast area. This capability will not require architectural changes, mainly the *payload* system will pick up the responsibility of storing communication data as well as processing basic commands and protocols.

3. **Distinguish Facial Features**

The ability to distinguish human facial features will greatly improve the capability to detect and track targets as well as search out particular enemies. This capability includes the MAV searching for a particular person by analyzing facial features when searching enemy targets and labeling them as 'possible enemy personnel'. No architectural changes will be needed; the recognition system or enhanced processing power can be added as a *Payload* to the MAV.

4. **GPS Jamming**

The capability to deny enemy forces access to GPS data can be accomplished using a MAV. This capability will also jam the current architected source for navigation information and would require a coupled secondary navigation capability (improved inertial navigation system, terrain mapping, etc). The GPS jammer can be added as a *Payload* and an INS or other non-GPS dependant navigation system will need to

be added to the *Air Vehicle* system. The non-GPS navigation system may require architecture changes based on what data links are required to perform navigation. These could include data links to additional sensors in the MAV payload, or data links to the operator that would perform as a origin point for navigation reference.

5. IR Reconnaissance

The capability to conduct infrared (IR) reconnaissance will greatly improve the *over-the-hill reconnaissance* missions, as well as any other operating scenario. Such thermal imaging systems will enable the MAV to see during the night as well as in most poor weather conditions. This capability also enhances the ability to detect, track, and identify critical targets. Current IR systems will first need to be miniaturized and require lower power to conform to the MAV's payload constraints. Since the IR system could be placed in the current ISR MAV payload sensor construct, no architectural changes are necessary for this capability.

6. Locate Targets Through General Land Obstacles

The capability to locate targets through general land obstacles such as trees is being pushed as a need from the user community [12]. A MAV with such ability to see through trees or other general land obstacles greatly increases the chance of locating an enemy when performing area surveillance or reconnaissance. Such technological issues like what systems to use, what amount of image processing is necessary, and possible error sources need to be researched. No architectural changes are expected, however minimal changes may be necessary based on a more refined capability description.

7. Small Ordinance Delivery Platform

This capability allows a MAV to serve as an air-to-ground attack vehicle either through weapon delivery or by itself acting as the ordinance. Users will be able to search and perform reconnaissance while retaining the option to attack or run into the enemy. This capability can be implemented currently but to create an adequate impact on the enemy, the small ordinances must be lighter and more destructive. If the MAV is to be used as an ordinance itself, no architectural changes are needed, but a less elaborative *Air Vehicle* system could be used to decrease costs. If the MAV is to actually deliver ordinance, then a system function of ordinance release is needed as well as the data elements to impart the release commands.

8. Suppression of Enemy Air Defenses

With the SEAD capability, a MAV can help ground units locate an enemy air defense system by either 'homing in' on its active radar or simply performing visual reconnaissance. The MAV could also act as an anti-radiation missile if this capability is coupled with the *small ordinance delivery platform* capability.

However, this seems to turn the MAV into more of a short range munition rather than an air platform. If this was added as an optional ‘payload’ then the MAV still acts as a multi-purpose air vehicle. This capability will not require direct architectural changes; however certain activity changes and information flows in the OV-5 and OV-6C will need to be made.

9. Laser Designation of Targets

The term target painting or *lasing* generally involves a laser pointing to a target while a weapon delivered from a delivery platform follows the laser to the target. Currently, ground units pack in equipment to laser designate a target but if a MAV is also being packed in, it makes sense to have the MAV also complete this task, thus eliminating a system having to be carried in (if the MAV has the capability to swap out payloads). This capability keeps friendly ground units at safer distances from the target. Technical issues to be resolved are developing a sufficiently powered laser to conform to the MAV form factor. This capability requires minor architectural changes with the addition of a *Target* and *Ordinance Entity* external node as well as more emphasis on the need for information exchange between the *Friendly Ground Unit* and *Strike Assets*.

10. Weather Intelligence Platform

The capability for an MAV to gather weather intelligence information will aid ground units that already conduct such missions as well as give other units this capability as well. As the name states, the capability to gather weather intelligence includes anything from humidity, temperature, wind speeds, and other information that would be of use to the user. This capability requires minor architectural changes, mainly on the OV-5 activity and OV-6C event diagrams to reflect the sampling and tracking of the weather conditions.

11. Operation in Urban or GPS Denied Environments

This is one of the most challenging missions for the current generation of MAVs. Urban environments are challenging due to the proliferation of obstacles. These obstacles prevent line-of-site communication and increase the chance of a collision. To operate in this environment, MAVs must be equipped with collision avoidance sensors and some type of communication method that allows line-of-site communication. Another solution to the line-of-site problem is to implement a communication relay MAV that could loiter above the urban environment to relay information to and from MAV. GPS denied areas require MAVs to have a secondary source of navigation data. This could be something similar to the Digital Terrain Elevation Database or some kind of intelligent mapping software. The MAV must have a way of knowing where it is to operate correctly. Adding the capability to operate in these adverse environments affects the architecture by requiring the addition of new communication lines and nodes to reflect the additional sensor data

or navigation processor.

Long Term Mission Capabilities: All long term mission capabilities listed here will require major technological improvements and breakthroughs as well as a large push from the user community before they can be pursued. Due to this, no architectural changes have been listed for any of the long term capabilities because technology and user needs will drive the changes needing to be made.

1. Electronic Signal Directional Finding

In this capability, a MAV is able to locate enemy broadcasting electronic signals. Such applications can include searching for enemy jammers, radars, other MAV operators, or whatever the sensor is tuned to pick up. With this, ground units will be able to conduct electronic reconnaissance or anti-electronic warfare. There are many technological improvements that must occur before this MAV capability can be realized.

2. Land or Sea Mine Scout

This capability allows a MAV to search out either land or sea based. The MAV would be packaged with sensors capable of locating and identifying possible mines. Users could deploy the MAV with such capability to scout ahead of the planned route and relay back information if a mine is discovered.

3. Target Identification and Tracking

The Target Identification and Tracking capability takes the short term *Target Tracking or Following* capability and adds target identification to it. This gives the ground units a more capable and autonomous MAV that is not only able to track the enemy but also identify it. Identification can be conducted through a wide range of sensors that detect optical, IR, or acoustic properties. One of the end goals for any ground unit is to know the location and status of enemy forces, so ideally a spin-off of this capability is multiple target identification and tracking with a MAV (or multiple networked MAVs). Such capability helps lift the ‘fog of war’ and gives friendly forces the upper hand.

4. Localized Deployment with External Control

This capability reflects a fundamental shift in how the information from the MAV and control of the MAV is handled. This capability enables an external source (another unit, a forward air controller, Joint STARS, AWACS, etc) to control the flight plan of the MAV once the ground user launches the MAV. The current architecture assumes the MAV is only controlled by the user so provisions for

handing off control of the MAV need to be implemented. A second component of this capability is to have the data from the MAV be routed directly to external sources. This baseline architecture assumes the data must pass through the ground station operator prior to dissemination to external sources. Thus, all of the communication lines which pass from the MAV to the ground station node must also be sent to the external user. Implementing this capability affects basically every diagram in the architecture.

4.5.2 Future Technology Discussion. After listing the possible future MAV mission areas it is apparent that some of the key technologies driving the mission need to be listed. The future technologies were generated by observing and analyzing the users background and capability deficiencies (Section 2.1), the baseline architectures (Section 4.3), and the future capabilities (Section 4.5.1). Some technologies are not directly apparent through the analysis and were retrieved from cited sources. These technologies are placed into two separate categories based on how well they benefit the current and future mission areas mentioned throughout this research. The first category (Figure 4.23), lists those technologies that most benefit the future mission areas while the second (Figure 4.24), lists those that are not directly related to the mission areas but are still important to the development of the MAV and its missions. For the first set of technologies, a brief description is provided to help demonstrate their importance in enabling or improving a MAVs mission area.

1. Enhanced Optical Sensor Capabilities

Current MAV applications and capabilities use onboard optical sensors, or cameras, for reconnaissance. To improve these sensors, new capabilities could be added such as optical zooming, camera slewing, or automatic focusing. Such added technologies will improve the MAVs operational effectiveness and suitability.

2. Mobile Ground Station When MAV Deployed

Having GPS, or another navigation source, integrated into the ground station enables the operator to view their location in respect to the MAVs. This means that both the location of the operator and MAVs is displayed through the human interface. With this, a better sense of situational awareness and increased mobility can be achieved.

Future MAV Technology Capabilities



Figure 4.23 Future MAV Technologies

3. **Integrated Ground Station**

This technology includes integrating all systems needed by the ground station into a single system that is lightweight and easily packable by a single user. An example is having the transmitter, receiver, power supply, and human interface integrated into a single unit that is the size of a PDA. Several technological improvements in the realm of miniaturization and power supplies will need to occur before such capability can be pursued.

4. **Low Light Emitting Display**

Night operations require the operators to remain hidden and avoid disclosing their position to enemy forces. If a MAV is to operate in night-time or low light environments, then the user interface needs to conform to the concealment requirement. To do this, the user interface display unit needs to emit little or no light beyond what is necessary for the user. Current technologies offer solutions to enable this capability such as helmet mounted displays used in aircraft or even a small monacle-type display that fits over the user's eye.

5. **Low Probability of Intercept Communications**

In Section 2.1.2, it was mentioned that special reconnaissance teams required the need for long range and low probability-of-intercept radios to improve their mission effectiveness. This requirement is intended for transmission between the ground force and higher headquarters; however, it should also be the case for ground to MAV communication. Without a communication system having a low probability-of-intercept, the enemy can triangulate the units location or, at the very least, know there is a unit in the vicinity - eliminating the element of surprise.

6. Modular and Swappable Payloads

Modular and swappable payloads involve the operator being able to change a MAV's payload before or after flight. An example could be that the operator carries an optical payload, an ordinance delivery payload, and a chemical detection payload for the MAV. The operator then decides which payload to attach to the MAV before launching. This technology allows the operator to freely choose the payload based on the current threat or battlefield situation.

7. Multiple Sensor Payload

Having multiple sensors in a single payload increases mission efficiency while the MAV is in-flight. A simple example of this is a payload that contains both chemical detection equipment and optical sensors such as a reconnaissance camera. One use for such a payload could be to alert the operator of a presence of a harmful chemical while conducting video reconnaissance. There are many different sensor combinations possible. Determining which combinations are best suited for the current mission will be based on the operator and the mission environment.

8. Non-Line-Of-Sight Communications

As the MAV increases its range and maneuverability, especially in urban environments, communications that do not require line-of-sight will become a greater user need. With these non-line-of-sight communications, operators can remain in a concealed area without having to relocate to keep the MAV's signal. Current technologies can enable such capability but are not yet feasible to implement on a MAV.

9. Reduce DTED Level 2 in Real-Time

Incorporating the digital terrain elevation database (DTED) into the MAV's navigation system will allow the system to have a sense of height above ground. Current architectures assume GPS as the sole input to the navigation system. However, this could be augmented if both GPS and DTED are implemented to allow the MAV's position to be calculated (GPS) along with its elevation above ground (DTED). Due to current payload, signal processing, and power constraints onboard the air platform, a short term solution could be to keep GPS onboard while DTED is integrated into the ground station signal processor unit. With this, the air platform's position would be sent to the ground station and as an acknowledgement the elevation for that position could be sent back to the air platform. The current resolution of DTED Level 2 is approximately 30 meters in altitude (highest DTED level to date), which is good enough for a larger UAV or manned aircraft but, depending on the MAV's application, may not be good enough. Future DTED levels such as Level 5 with its proposed 1 meter resolution will better suit the MAV. However, if resolution increases to this level, the file size is likely to be very large (requiring more storage space or portable media containing data for a particular

geographical area). Terrain mapping can be a derived technology once DTED Level 2 is incorporated, however this mapping technology will be limited based on resolution available and processing speed.

10. Sensor and/or Image Stabilization

Adding sensor or image stabilization to a MAV will aid the operator by identifying targets faster and more accurately. Stabilization can either occur onboard the air platform or at the ground stations signal processor. Results will most likely be better if stabilization takes place onboard the platform but there are techniques that could be incorporated into the ground station signal processor. An example of an onboard stabilization system could include a camera mounted to a pod where the pod rotated based on the airframes change in pitch, roll, or yaw. For the ground based system, an example is that a computer could take picture stills from the incoming video such that the operator does not notice the image *bouncing* around as much. Such sensor stabilization aids mainly by reducing operator fatigue while enabling faster, more accurate target identification.

Other Possible Future MAV Technologies

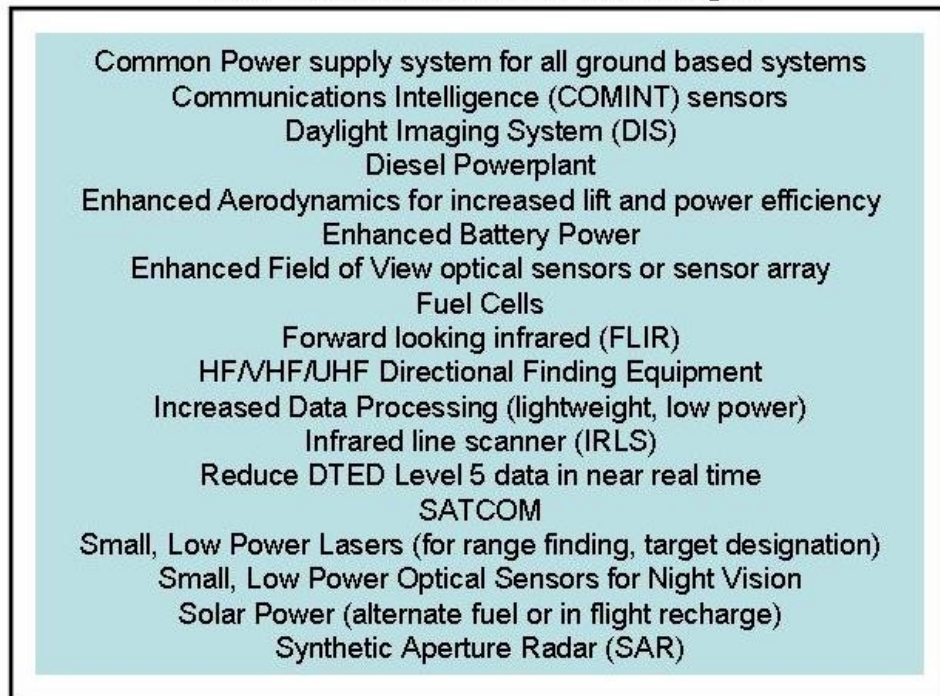

Figure 4.24 Other Possible Future MAV Technologies

As discussed, there are ample areas of study and research that provide both near-term and long-term benefits to the operational MAV community. While an attempt was made to delineate which areas are more attainable in the various *time spaces*, it will ultimately be the operational community along with identified capability gaps that will guide which technologies are actively pursued.

V. Conclusions and Recommendations

5.1 Conclusions

The goal of this thesis was to apply good systems engineering principles to develop a mini/micro unmanned aerial vehicle (MAV) architecture model describing their use in three separate but closely related mission areas: Over-the-Hill-Reconnaissance, Battle Damage Information (BDI), and Local Area Defense (LAD). These mission areas are derived from the special operations forces (SOF) background, mission tasks, and their capability deficiencies presented in Chapter II. The general terms of unmanned aerial vehicle (UAV) and MAV were introduced to provide insight into the system architecture used to fulfill the special operations forces capability deficiencies. With an increased understanding of the user, their operating environment, and the general concepts of both UAVs and MAVs, this thesis was scoped to architecting a single-man-packable and single-man-operable intelligence, surveillance, reconnaissance (ISR) MAV system that does not require the carrier to sacrifice normal mission essential gear. Architecturally, the MAV system was defined to contain two cohesive elements, an airborne and a ground element, where both elements are required for mission operation.

Such a MAV system is designed to meet current capability needs; however, a proper system engineering architecture approach is needed since missions and operating environments often change. Likely changes include systems that are needed to interface with the MAV as well as updated user requirements. Applying a uniquely designed MAV to a changing environment is more likely to require a new system rather than modifying a current one. With the use of the systems architecture approach, the MAV system could be designed or described in such a way that allows for future refinement, growth and application.

A comprehensive description of the methodology used in this thesis was put together in Chapter III to benefit those unfamiliar with the architecture models of systems as well as the many different forms of models available. This methodology included the

traceability approach used as well as description of architecture models presented in the DoD Architecture Framework (DoDAF). Throughout this thesis, traceability was a key element ensuring that the architectures developed would be integrated. This began with the realization that a capability gap exists and ends by defining specific functional tasks.

The bulk of this thesis is the application of the DoDAF to the MAV system. Using the methodology formulated, all findings, operating scenarios, system traceability efforts, and resulting architectures were presented. These results enable the creation of a set of baseline integrated architecture products for a MAV focused in the ISR realm. To further expand and make this effort more complete Doctrine, Organization, Training, Leadership and Education, Personnel, and Facility (DOTLPE) considerations were addressed, and plausible future capabilities and technologies were discussed. Through the use of the systems engineering process, these results met the goal of this thesis by providing an integrated MAV architectural model describing a general ISR mission with emphasis on three mission areas: Over-the-Hill-Reconnaissance, Battle Damage Information (BDI), and Local Area Defense.

5.2 *Remarks*

Due to the refocus on Systems Engineering in the DoD, integrated architectures are now required for all current and future acquisition programs. The products presented in Chapter IV can be applied to any MAV program to be compliant with these regulations. The developed architecture products also present the first academically constructed set of architecture products for a real-world capability.

Creating these baseline products also allows the designers and system engineers to further decompose the system into the key measures which define the trade space for the MAV system. These key measures for the MAV itself are: weight, size, level of discrimination, interoperability, area search size and area search rate. For the ground station, they are portability, size, and level of concealment. Once these key measures are identified, the designers can then derive applicable requirements for the system that are

based on the architecture products (interfaces, information exchanges, operational nodes, etc.) as well as any specific requirements based on the key measures.

5.3 Recommendations

Following this research, the authors recommend that the sponsor and any MAV-related organizations review and establish this ISR MAV architecture as the baseline for the current ISR MAV capability. This architecture also needs to be reviewed and iteratively updated to reflect how ISR MAVs fit into the mission of its users. As with any effort to model a system, there are several levels of detail that can be achieved to enable a more refined view of the system.

Now that a baseline structural model has been developed for the ISR MAV, temporal modeling of the system can, and should, be developed that will better describe the performance parameters of the system. The static model presented in this research forms the foundation for the dynamic models that can be used to fully evaluate the system's strengths and weaknesses as different designs are tested. Specific instantiations of this architecture can also be researched to guide development of other members of the family of systems. While this architecture dealt with the mission areas of ISR, related architectures for supporting and supported missions performed by MAVs should also be developed. All of these architectures and the linkages between them will truly enable an integrated look at the emerging field of MAVs in the DoD.

5.4 Future Areas of Study

This thesis deals mostly with the Concept of Operations and the resulting architectures for the use of MAVs in the US Air Force. Its scope includes only single-man-packable/launchable systems and is the first of its type to academically architect the MAV system. The following areas of study are presented either because they fell outside of the scope of this thesis, they represent further study of threads presented in this thesis, or simply will help to understand and integrate the use of MAVs in the military of today and

tomorrow. The future areas of study (FAS) below are presented with the understanding that they would be completed in and with the focus of a systems engineering approach unless otherwise stated.

FAS1: Swarming MAV detailed architectures. This would take any "to-be" architectures and/or ConOps developed on the topic and fully explore the ConOps, architectures, behavior rule models, and challenges facing this area of MAV use.

FAS2: Detailed systems architecture of the miniaturization of remote aerial target designation (lasing). This requires study and description of the target designation mission, functions, current technologies, future technologies, and the challenges facing their miniaturization to a MAV level.

FAS3: DoD integration of MAV use. Since this thesis aimed mostly at USAF missions and operations to develop capabilities and ConOps, this area of study would take a higher, and less detailed look at MAV use, but with a purple focus. It would seek to develop what high level architectures would need to be agreed upon and established in order to better integrate the use of MAVs between services.

FAS4: MAV observation/targeting stabilization study and analysis. This FAS would need to be performed by an aeronautical engineering Masters/Doctorate-seeking student. The study would use the currently fielded MAV systems as a baseline and seek to adjust various design characteristics to yield the most stable flight platform as possible to provide useful EO intelligence. Modeling, wind tunnel testing and publishing of results would be of great benefit to the currently fielded MAV development lab and SPO.

FAS5: Full To-Be MAV architectures. The extension would develop full architectures of proposed future capabilities as presented in Chapter IV of this thesis. While the future capabilities were all introduced and discussed here, a full compliment of architecture products are necessary to flush out implications to practical MAV application.

Appendix A. MAV List of Acronyms

Table A.1 – List of Acronyms

Acronym	Description
AF	Air Force
AFMC	Air Force Materiel Command
AFRL	Air Force Research Laboratory
AFSOC	Air Force Special Operations Command
AFTL	Air Force Task List
AOC	Air Operations Center
AV	All View
BATCAM	Battlefield Air Targeting Camera Autonomous Micro air vehicle
BDA	Battle Damage Assessment
BDI	Battle Damage Information
C ³	Command, Control, Communications
C4ISR	Command, Control, Communications, Computers, Intelligence, Surveillance, and Reconnaissance
CAO	Civil Affairs Operations
CCT	Combat Controller
CDD	Capability Development Document
CLS	Contractor Logistics Support
COMINT	Communications Intelligence
COMM	Communications
CP	Counter-Proliferation
CPD	Capability Production Document
CT	Counter Terrorism
DA	Direct Action
DBMS	Database Management System
DIS	Daylight Imaging System
DLA	Defense Logistics Agency
DoD	Department of Defense
DoDAF	Department of Defense Architecture Framework
DOTMLPF	Doctrine, Organization, Training, Materiel, Leadership and Education, Personnel, and Facilities
DTED	Digital Terrain Elevation Database
EW	Electronic Warfare
FID	Foreign Internal Defense

Continued on next page

Table A.1 – continued from previous page

Acronym	Description
FLIR	Forward Looking Infrared
FoS	Family of Systems
GPS	Global Positioning System
HCI	Human Computer Interface
HF	High Frequency
I/O	Input or Output
IA	Integrated Architecture
ICD	Initial Capability Document
ICOM	Input, Control, Output and Mechanism
IEEE	Institute of Electrical and Electronic Engineers
IMINT	Information Intelligence
INS	Inertial Navigation System
IO	Information Operations
IR	Infrared
IRLS	Infrared Line Scanner
ISR	Intelligence, Surveillance, Reconnaissance
JCIDS	Joint Capabilities Integration and Development System
JFC	Joint Functional Concept
LAD	Local Area Defense
LAN	Local Area Network
LISI	Level of Information Systems Interoperability
LOS	Line-Of-Sight
MAV	Mini and Micro Unmanned Aerial Vehicle
METL	Mission Essential Task List
NIST	National Institute of Standards and Technology
OJT	On the Job Training
OJT	On the Job Training
OTHISR	Over-The-Hill Intelligence Surveillance Reconnaissance
OV	Operational View
PSYOP	Psychological Operations
QRC	Quick Reaction Concept
Recon	Reconnaissance
RPV	Remotely Piloted Vehicle
SAR	Synthetic Aperture Radar
SATCOM	Satellite Communication
SE	Systems Engineering
SEAD	Suppression of Enemy Air Defenses
SIGINT	Signals Intelligence
SOF	Special Operations Forces

Continued on next page

Table A.1 – continued from previous page

Acronym	Description
SoS	Systems of Systems
SPO	System Program Office
SR	Special Reconnaissance
SV	Systems View
TV	Technical Standards View
UAV	Unmanned Aerial Vehicle
UHF	Ultra High Frequency
UJTL	Universal Joint Task List
US	United States
USSOCOM	United States Special Operations Command
UW	Unconventional Warfare
VHF	Very High Frequency
WAN	Wide Area Network
WMD	Weapons of Mass Destruction
WWII	World War II

Appendix B. MAV Traceability

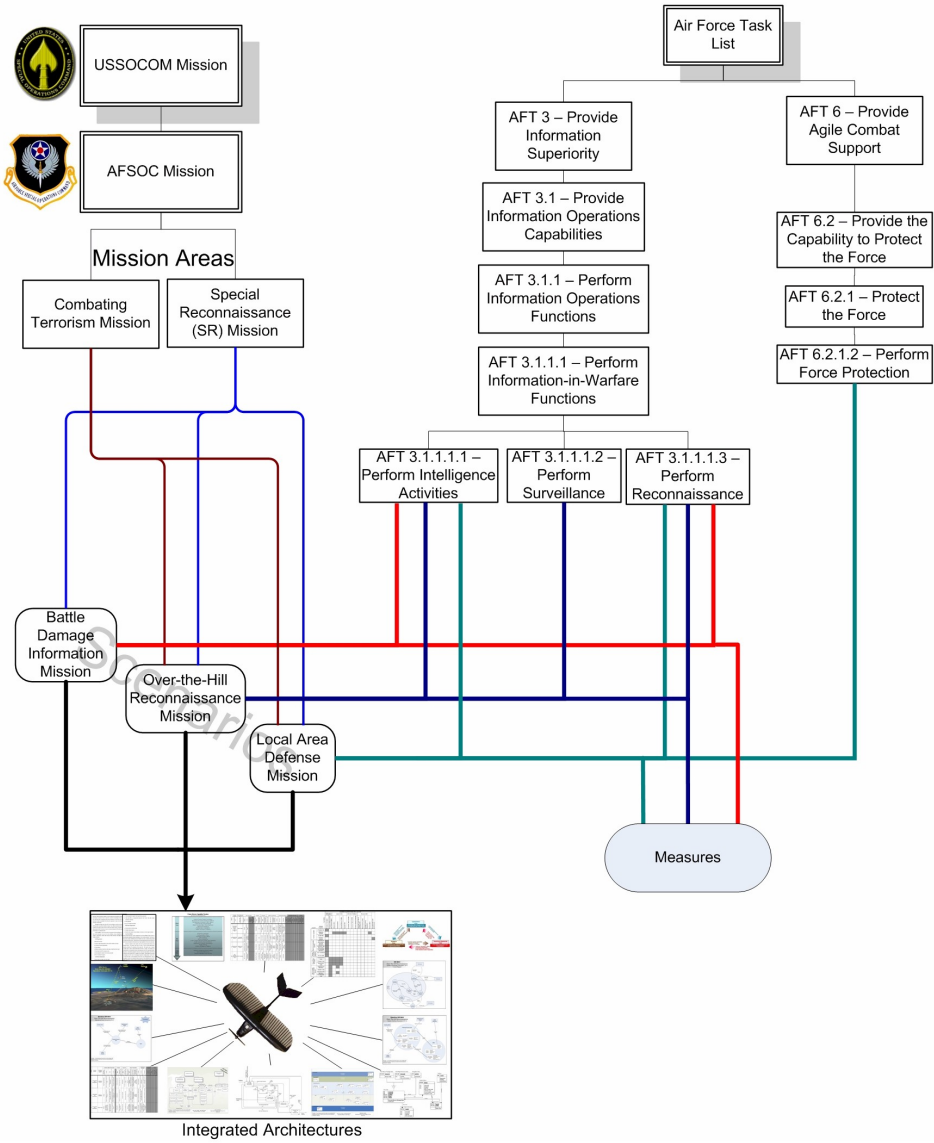

Figure B.1 Top Level Traceability Diagram

Appendix C. MAV AV-1

AV-1: Overview and Summary Information

ISR MAV (AS-IS)

1. Identification Name: Intelligence, Surveillance and Reconnaissance Micro/Mini Aerial Vehicle (AS-IS). **Short Name:** ISR MAV (AS-IS) Architecture. **Involved Organizations:** AFRL/MN: Munitions Directorate, ISR MAV developer; AFRL/HECB: Human Factors Lab, Battlefield Air Operations (BAO) integrator; ASC/AAP: Aeronautical Enterprise Program Office, System Program Office (SPO); AFIT/ENY-GSE: USAF Graduate Systems Engineering program, architecture developers. **Date:** This version targets the FY05 timeframe. The period for the development of this version of the architecture was August 2004 to March 2005.

2. Background: There currently does not exist an integrated architecture that defines the use of the emerging field of Mini/Micro Aerial Vehicles (MAV) within the Department of Defense, or the US Air Force. MAVs are rapidly emerging as a productive subset of the larger category of Unmanned Aerial Vehicles (UAV). They are loosely defined by being small enough in size and weight to be man-packable for use in austere operational environments by Special Forces Personnel. The MAV's size and ease of testability allows for rapid development and modification of design and application.

This architecture is an AS-IS representation of a generic ISR-focused MAV. It is based in large part on the design and operations of currently operational MAV systems. There is a need for a baseline architecture in order to understand the systems, track changes that are made, and project forward to determine capability shortfalls that should be addressed.

3. Purpose: The ISR MAV (AS-IS) architecture will baseline the current capabilities of operational ISR MAVs. The purpose of this version of the architecture (FY05) is detailed in the table below.

4. Scope: The products associated with this architecture depict the AS-IS state of a generic ISR MAV system. This architecture includes the infrastructure and systems needed to operate an ISR MAV by US military personnel.

5. Time Frame: The architecture depicts the weapon system in its current state and certain evolutions expected to be implemented through FY05. Realistically, the first POM cycle that the completed architecture would be able to influence is FY08.

Table C.1 Architecture Purposes

Architecture Purpose	Architecture Product Implications
Describe a generic ISR MAV system as a baseline to fully map the necessary interfaces needed to describe the ISR MAV mission.	Architectural elements are documented that are common to the ISR MAV mission and can be used to fully understand the system's boundaries and interfaces.
Support the development of an ISR MAV Full Scale Production Contract and serve as a maintained, authoritative decision making tool after contract award	Information must be accurate and authoritative. Products should be built with the idea in mind that the future changes to the mission profile and integrating advanced technology will need to be reflected in the baseline architectures prior to implementation
Support the design of tailored ISR MAV implementations	The generic architecture should be extensible to reflect C2 node or site specific variations of ISR MAVs without losing linkage and consistency with the baseline architecture products
Provide traceability of requirements to architecture components	To be meaningful, the granularity of the architectural elements should be small
Support the development of future test plans	The SV-1 will provide system to system interoperability requirements while various other OV/SVs will aid in determining system connectivity and interoperability requirements
Identify modernization opportunities	Need to be able to <i>tag</i> architecture elements as being candidates for replacement, re-engineering, or additional capabilities
Support future POM/APOM activities by contributing to the refinement of AOC requirements helping identify areas for modernization	Requires significant granularity across a variety of OV and SV products
Be an integral part of the larger ISR and/or UAV architecture	Use of same or interoperable toolsets, terminology, and supporting architecture databases

Appendix D. MAV OV-1

Table D.1 – AV-2 Integrated Dictionary

Entities, Attributes, and Relationships	Description
Graphical Box Types	Icons
MAV	Description: This icon represents the aerial vehicle portion of the overall MAV system being architected.
CCT/MAV Operator	Description: The CCT/MAV Operator is comprised of any person trained to set up and operate a MAV system. CCT is shown on the ISR/BDI operational concept and MAV operator is shown on the Local Area Defense operational concept. The CCT/MAV operator is an integral part of the Friendly Ground Unit or Special Ops Unit described in the OV-2, OV-6c, and SV-1b views. The operator either affects the system through direct contact (Platform Interface, Field Comm Interface, and Hardware Interface) or through the HCI system (User Feedback and Inputs interface). Type: Operational Node, Activity, or System Views: OV-1
GPS Satellite	Description: The Global Positioning System consists of a constellation of satellites providing pseudorange numbers and ephemeris data. Receivers use this information to calculate their location. The data provided by GPS satellites is required by MAVs in order to generate their current location and perform waypoint navigation. Type: External system Views: OV-1, OV-2, OV-6c, SV-1b/c
Continued on next page	

Table D.1 – continued from previous page

Entities, Attributes, and Relationships	Description
AOC	<p>Description: The AOC is an external system that encompasses any unit or group that the operator is required to report to, or is considered at a higher level in the operators chain of command. This unit can be stationed locally in respect to the operator (in the field) or remote (far away from the operator). Headquarters can do any number of tasks, including making decisions based on gathered intelligence, assigning missions or directives to field units, or providing intelligence information. The AOC is synonymous with Local Commanders or Headquarters on OV-2, OV6c, and SV-1b/c products.</p> <p>Type: External system Views: OV-1</p>
COMM Satellite	<p>Description: COMM satellites provide the CCT/operator a means to communicate with decision authorities.</p> <p>Type: External system (not shown on other products) Views: OV-1</p>
Strike Asset	<p>Description: Strike assets are external systems that are comprised of any operational unit that has the capability to inflict damage on the enemy. Examples include aircraft (A-10), ground units (artillery), or sea based units (cruiser). Strike assets can be employed as a result of information obtained via the MAV and communicated to Headquarters or the local commander.</p> <p>Type: External system Views: OV-1, OV-2, SV-1b/c</p>
Threat	<p>Description: Threats are any enemy personnel or enemy systems that would interfere with friendly force objectives.</p> <p>Type: External system Views: OV-1</p>
Graphical Arrow Types	
Continued on next page	

Table D.1 – continued from previous page

Entities, Attributes, and Relationships	Description
Navigation Data	<p>Description: Depending on the view, navigation data can either be an operational needline (OVs) or an external interface (SVs). This link includes the pseudorange numbers and ephemeris data transmitted by the GPS satellites.</p> <p>Type: External Interface or Needline</p> <p>Views: OV-1, OV-2, OV-5, SV-1b/c</p>
Data and Telemetry	<p>Description: Data and Telemetry is the link between the operator and the aerial part of the MAV system that provides both sensor data and necessary air vehicle information. Data and Telemetry is synonymous with Platform Communications on OV-2, Request/Commands, and ISR data on SV-1b, and Raw Sensor Package Data/Raw Flight Telemetry on OV-5 (A0 view).</p> <p>Type: Internal Interface or Needline</p> <p>Views: OV-1</p>
Comm Link	<p>Description: Comm Links comprise any communication link used by CCTs/MAV operators/Friendly Ground Units in order to relay information to the applicable decision authority or strike force (to include personnel and aircraft) in the prosecution of mission objectives. Comm Links are synonymous with Communicate with Headquarters and Communicate with Local Strike Assets on the consolidated OV-2. They represent Information Gathered, Mission Tasks and Intelligence Info and BDI request, Scheduled Attack, and Enemy Position on the SV-1b</p> <p>Type: External interface or Needline</p> <p>Views: OV-1</p>

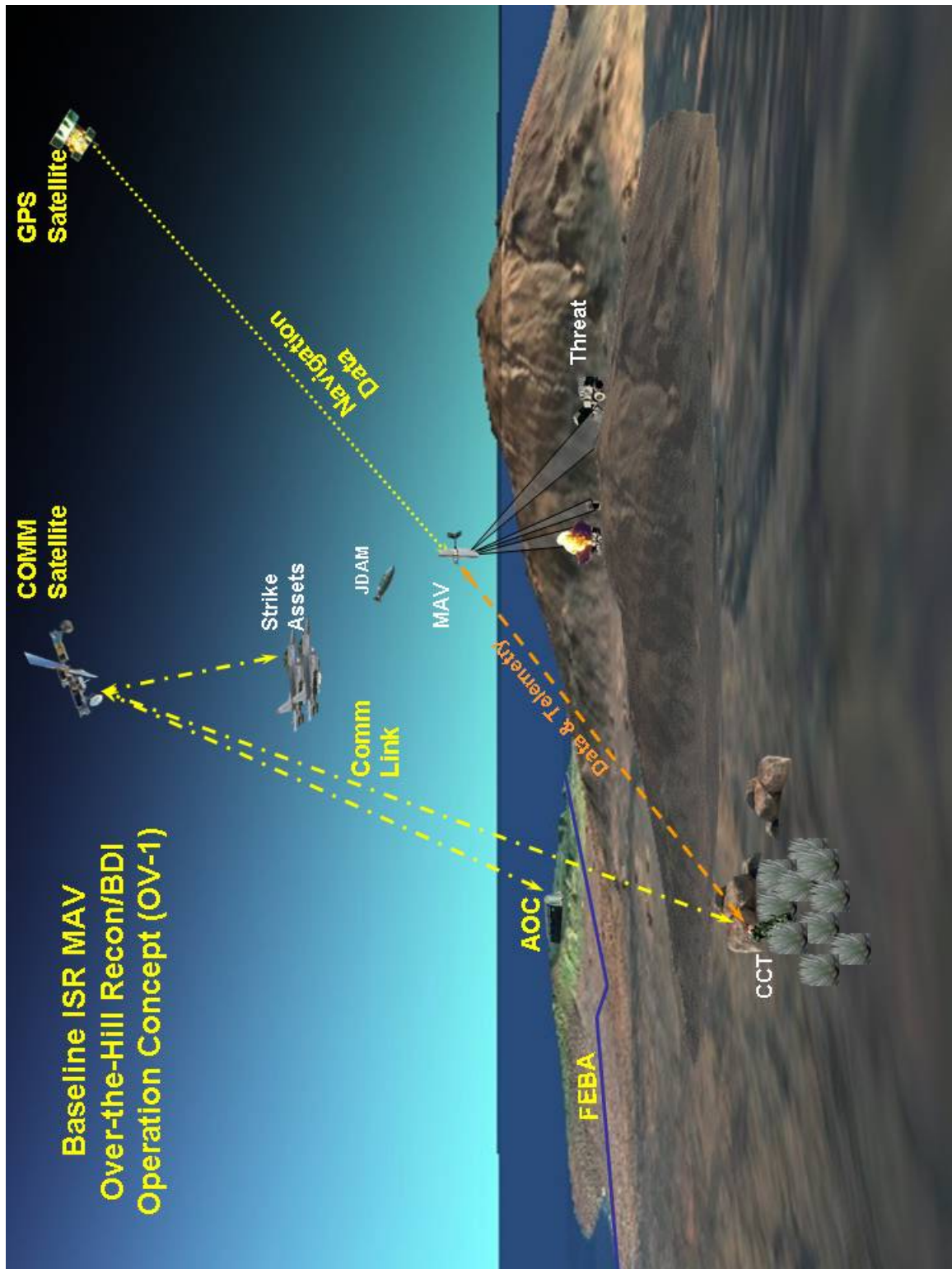

Figure D.1 OV-1 for the OTHISR and BDI Scenario

Appendix E. MAV OV-2

Table E.1 – AV-2 Integrated Dictionary

Entities, Attributes, and Relationships	Description
Graphical Box Types:	Operational Nodes
Friendly Ground Unit	<p>Description: The Friendly Ground Unit operational node includes all systems that make up the ground piece of the overall system. Synonymous with CCT, MAV Operator, or Perform Ground Unit Functions.</p> <p>Type: Operational Node</p> <p>Views: OV-1, OV-2, OV-3, OV-6c, SV-1b, SV-1c, SV-4</p>
MAV	<p>Description: The MAV operational node includes all systems that make up the airborne piece of the overall system. Synonymous with Perform MAV Functions.</p> <p>Type: Operational Node</p> <p>Views: OV-1, OV-2, OV-3, OV-6c, SV-1b, SV-1c, SV-4</p>
Graphical Box Types:	External Operational Nodes
GPS Satellites	<p>Description: The Global Positioning System consists of a constellation of satellites providing pseudorange numbers and ephemeris data. Ground based receivers use this information to calculate their location.</p> <p>Type: External Node</p> <p>Views: OV-1, OV-2, OV-3, OV-6c, SV-1b, SV-1c, SV-4, SV-6</p>
Headquarters	<p>Description: Headquarters encompasses any unit or group that the operator is required to report to, or is considered at a higher level in the operators chain of command. This unit can be stationed locally in respect to the operator (in the field) or remote (far away from the operator). Headquarters can do any number of tasks, including making decisions based on gathered intelligence, assigning missions or directives to field units, or providing intelligence information. Synonymous with AOC or Local Commanders.</p>
Continued on next page	

Table E.1 – continued from previous page

Entities, Attributes, and Relationships	Description
	Type: External Node Views: OV-1, OV-2, OV-3, OV-6c, SV-1b, SV-1c, SV-4, SV-6
Maintenance Depot	Description: The Maintenance Depot includes any operational unit outside of the system that performs maintenance or support on the system. Although the diagram only shows a need to communicate with the Friendly Ground Unit node, the Maintenance Depot can actually influence or perform maintenance on the entire system (including the MAV). The main purpose of this node is to perform maintenance that cannot be performed in the field by the Friendly Ground Unit. Type: External Node Views: OV-2, OV-3, OV-6c, SV-1b, SV-1c, SV-6
Strike Assets	Description: Strike assets are any operational unit that has the capability to inflict damage on the enemy. Examples include aircraft (A-10), ground units (artillery), or sea based units (cruiser). Type: External Node Views: OV-1, OV-2, OV-3, OV-6c, SV-1b, SV-1c, SV-4, SV-6
Graphical Arrow Types:	Needlines
Communicate with Headquarters	Description: This needline includes sending ISR information gathered to Headquarters, and receiving both mission tasks and intelligence information from Headquarters. Synonymous with ‘Information Gathered, Mission Tasks, Intelligence Info’. Information Exchange Direction: Bi-Directional Operational Node 1: Headquarters Operational Node 2: Friendly Ground Unit Type: Operational Needline Views: OV-2, OV-3, SV-1b, SV-1c, SV-6
Continued on next page	

Table E.1 – continued from previous page

Entities, Attributes, and Relationships	Description
Communicate with Local Strike Assets	<p>Description: Included in this needline are BDI request and feedback sent from and to the Strike Assets. BDI request include the type of strike, last known enemy positions (or location of strike) using a standardized coordinate system, and when the strike is scheduled (if not already occurred). BDI feedback includes general information sent back to the strike asset concerning BDI mission results. Synonymous with ‘BDI Request and Feedback’.</p> <p>Information Exchange Direction: Bidirectional</p> <p>Operational Node 1: Strike Assets</p> <p>Operational Node 2: Friendly Ground Unit</p> <p>Type: Operational Needline</p> <p>Views: OV-2, OV-3, SV-1b, SV-1c, SV-6</p>
Navigation Data	<p>Description: This needline represents a need to receive navigation data from GPS Satellites. The information needed includes the pseudorange numbers and ephemeris data which is transmitted by the satellites.</p> <p>Information Exchange Direction: Unidirectional</p> <p>From Operational Node: GPS Satellites</p> <p>To Operational Node 2: MAV</p> <p>Type: Operational Needline</p> <p>Views: OV-1, OV-2, OV-3, OV-5, OV-7, SV-1b, SV-1c, SV-4, SV-6</p>
Platform Communication	<p>Description: This needline shows that a need for communication between the ground (Friendly Ground Unit) and the airborne (MAV) operational nodes is required. Such communication includes request or commands to the MAV, gathered ISR data sent from the MAV to the Friendly Ground Unit, and a Platform Interface to allow the Friendly Ground Unit to directly interact with the MAV. Synonymous with ‘Data and Telemetry’.</p> <p>Information Exchange Direction: Bidirectional</p> <p>Operational Node 1: MAV</p> <p>Operational Node 2: Friendly Ground Unit</p> <p>Type: Operational Needline</p>
Continued on next page	

Table E.1 – continued from previous page

Entities, Attributes, and Relationships	Description
	Views: OV-1, OV-2, OV-3
System Maintenance Needed/Request	<p>Description: This needline shows that there is a need for communication between the Maintenance Depot and the Friendly Ground Unit nodes. Included here is the Friendly Ground Units request for maintenance to be performed on the system and the Maintenance Depots acknowledgement of completed maintenance. Such maintenance requests occur whenever the Friendly Ground Unit is not capable or it is out of the scope of field level maintenance.</p> <p>Information Exchange Direction: Bidirectional Operational Node 1: Maintenance Depot Operational Node 2: Friendly Ground Unit Type: Operational Needline Views: OV-2</p>
Relationships	
Operational Node	Organization Type
Friendly Ground Unit	Any size land based force (personnel and equipment)
MAV	ISR Gathering and Disseminating
Operational Node	Operational Activity
Friendly Ground Unit	Process Information (A11), Provides Vehicle Control and Communication (A12), Initialize MAV (A21), Calibrate MAV (A22), Upload Mission Profile (A23), Launch MAV (A24), Recover MAV (A44), Provide Field Level Maintenance (A5)
MAV	Provides Flight Controls (A31), Provides Flight Vehicle (A32), Enables Sensor Package (A33), Calculate Flight Plan to Landing Zone (A41), Fly to Landing Zone (A42), Perform Landing Sequence (A43)

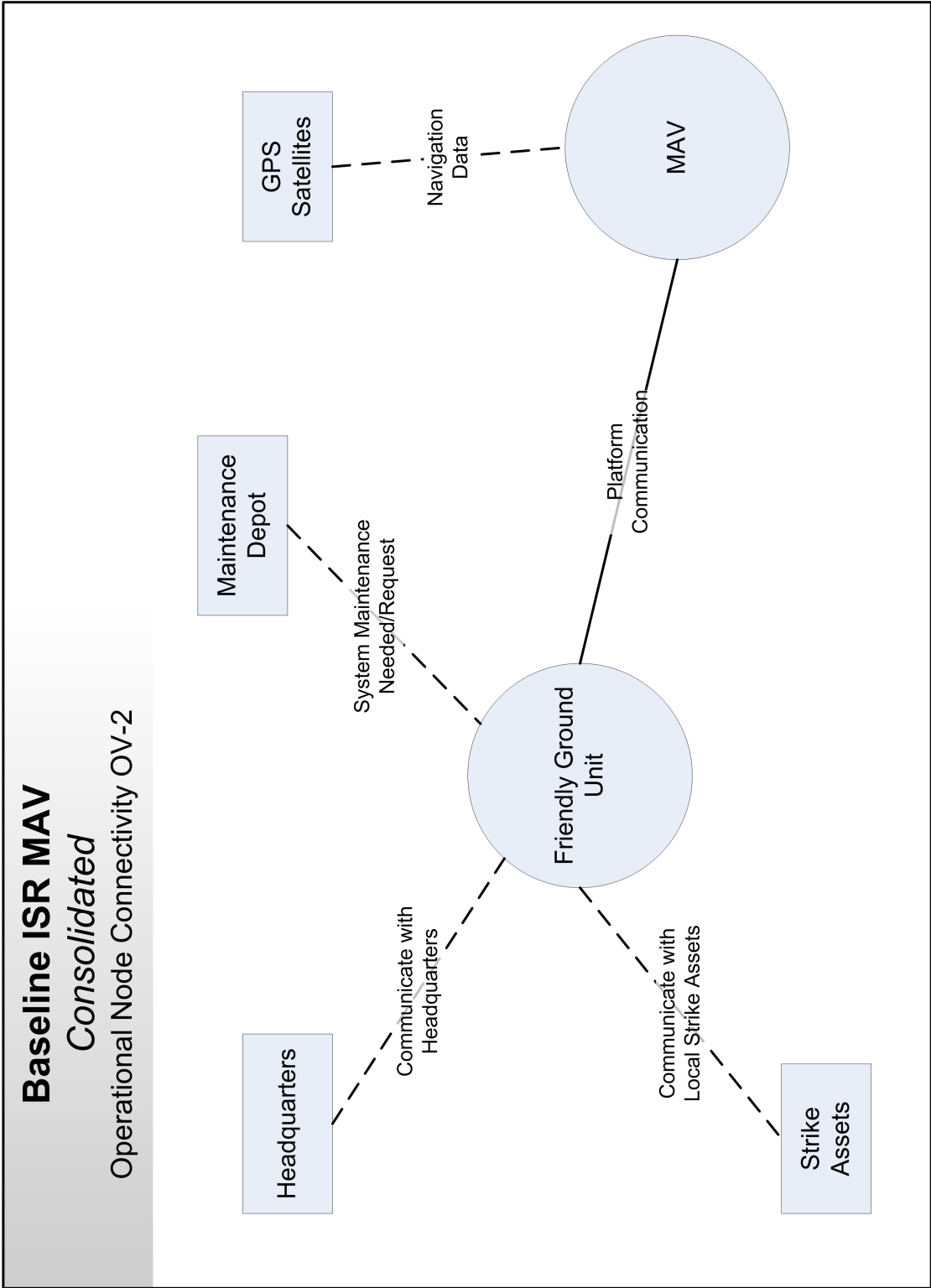

Figure E.1 Consolidated OV-2

Appendix F. MAV OV-3

As mentioned in Section 3.2.3, the OV-3 matrix, as with any defined matrix, is a set of rows and columns where their intersections contain information. The rows contain all information contained within a particular information exchange. Since the relationship between needlines and exchanges are one-to-many they are categorized first by the operational needline shown in the OV-2 and then by the information exchange identifiers which are OV-3 unique. The columns show specific information based on the columns heading. Many times, the column headings are tailored to the specific system type that is being modeled. A template for a highly complex, secure, and detailed communication system may have many extraneous columns for a simpler system with few information exchanges. The tailored list below is the column headings with their meanings as defined by DoDAF [24]. The columns outside the scope of this initial baseline architecture have been marked Left Blank. This research will still show these empty columns in order to allow for future detailed research. Following the column definitions are the OV-3 matrix figures completed for the Baseline ISR MAV.

Row ID: Contains a unique row number for each row and is used for easier referencing (instead of having to recite the information exchange identifier).

Needline Identifier: Identifies the needline as shown in the OV-2 operational node connectivity diagram that carries the information exchange.

Information Exchange Identifier: Identifies the information exchange, based on and contained within an operational needline, and is unique to the OV-3 matrix.

Information Element Name: Shows the corresponding information element, as shown in the OV-7, for the information exchange. This column can also include the information flow from the OV-5 if the OV-7 is not available or does not go into sufficient depth. For this research this column is based on information flows from the OV-5.

Content: Content of the information element, meaning the actual information to be exchanged.

Scope: Description of the extent or range of the information element content.

Accuracy: Degree to which the information conforms to actual fact as required by the operational node.

Language: Identifies the codes or natural languages involved in the information exchange (multinational). *Left Blank*

Sending Op Node Name: Name of the operational node from the OV-2 that produces the information.

Sending Op Activity Name and ID: Name and identifier of the operational activity from the OV-5 producing the information.

Receiving Op Node Name: Name of the operational node from the OV-2 that consumes the information.

Receiving Op Activity Name and ID: Name and identifier of the operational activity from the OV-5 consuming the information.

Mission/Scenario, UJTL, METL, or AFTL: Joint Mission Area, cross-mission area domain, Universal Joint Task List (UJTL) activity, related specific scenario, Air Force Task List (AFTL), or other mission/scenario task-related publication. For this research the AFTL were used as outlined earlier in the traceability section (4.2).

Transaction Type: Contains the type of exchange (in high-level terms).

Triggering Event: Textual description of the event(s) shown in the OV-6C that triggers the information exchange. If triggering events are not included in the OV-6C then this column is not required however an example of such a event can be given as the case with this research.

Interoperability Level Required (from C4ISR WG): Level of Information Systems Interoperability (LISI), or other interoperability measure. This research used the C4ISR Working Groups [10] interoperability levels. There are 5 possible levels of interoperability an information exchange can have, numbered 0 to 4. Level

0 is termed the Isolated Level and consists of manual access control procedures, manual infrastructure and private data. Level 1 is termed the Connected Level and consists of a security profile, two or one way infrastructure, and basic data formats. Level 2 is termed the Functional Level and consists of a common operating environment, a local area network (LAN) infrastructure, program models, and advanced data formats. Level 3 is termed the Domain Level and consists of domain procedures, a wide area network (WAN), database management system (DBMS), and domain models. Level 4 consists of enterprise procedures (DoD, Multi-National), multiple dimensional topologies, and cross enterprise models.

Criticality: The criticality assessment of the information being exchanged in relationship of the mission being performed, meaning how essential is it to the overall mission or capability.

Periodicity: How often the information exchange occurs; may be an average or worst case estimate and can include conditions.

Timeliness: Required maximum allowable time of exchange from node to node. This research uses *in minutes* and *in seconds* to state the order of measurement to be used for the information exchange.

Access Control: The class of mechanisms used to ensure only those authorized can access information. *Left Blank*

Availability: The relative level of effort required to be expended to ensure that the information can be accessed. *Left Blank*

Confidentiality: The kind of protection required for information to prevent unintended disclosure. *Left Blank*

Dissemination Control: The kind of restrictions on receivers of the information based on sensitivity of information. *Left Blank*

Integrity: The kind of requirements for checks that the content of the information has not been altered. *Left Blank*

Accountability: Security principle that ensures that responsibility for actions/events can be given to an organization willingly or by obligation. *Left Blank*

Protection (Type, Name, Duration): Name for the type of protection and how long the information must be safeguarded. *Left Blank*

Classification: Classification code for the information. *Left Blank*

Classification Caveat: A set of restrictions on information of a specific classification; supplements a security classification with information on access, dissemination, and other types of restrictions. *Left Blank*

3	2	1	Row ID	
Communicate with Headquarters	Communicate with Headquarters	Communicate with Headquarters	Needline Identifier	
Mission Tasks	Intelligence Information	Information Gathered	Information Exchange Identifier	
Tasking	Tasking	Fused Target Information	Information Element Name	Information Element Description
Type of Mission (Recon/BDI/LAD), Waypoints, Goals	Regional Intelligence, Possible Enemy Locations	Enemy Positions and Collected ISR Data	Content	
Contains type of mission, goals, and instructions	Includes any known enemy positions and geographical information	Any information being returned to Headquarters	Scope	
Users should understand the mission	Can be a best guess but the more accurate the Intel is the higher the chance of mission completeness	Information should be able to get from the system to Headquarters	Accuracy	
			Language	
Headquarters	Headquarters	Friendly Ground Unit	Sending Op Node Name	Producer
Provide Command and Control (A-2)	Provide Command and Control (A-2)	Process Information (A11)	Sending Op Activity Name & ID	
Friendly Ground Unit	Friendly Ground Unit	Headquarters	Receiving Op Node Name	Consumer
Process Information (A11)	Process Information (A11)	Provide Command and Control (A-2)	Receiving Op Activity Name & ID	
AFT 3.1 Provide Information Operations Capabilities	AFT 3.1 Provide Information Operations Capabilities	AFT 3.1 Provide Information Operations Capabilities	Mission/Scenario UJTL, METL, or AFTL	Nature of Transaction
Voice Transmission	Data or Voice Transmission	Data or Voice Transmission	Transaction Type	
Headquarters wishes to assign an ISR task	Updated intelligence information is available through Headquarters	User wishes to forward gathered ISR information to Headquarters	Triggering Event	
Level 0 Isolated (Manual)	Level 0 Isolated (Manual)	Level 1 Connected (Peer-to-Peer)	Interoperability Level Required (from C4ISR WG)	
Mission Essential	Needed to increase Mission effectiveness	Mission Essential	Criticality	
Occurs at the beginning of a mission and may be updated during mission	Occurs at the beginning of a mission and may be updated during mission	Depends on mission, may only occur a few times	Periodicity	Performance Attributes
Depends on mission and method of delivery (in minutes)	Depends on method of delivery (in minutes)	Depends on level of ISR requested (in minutes)	Timeliness	
			Access Control	Information Assurance
			Availability	
			Confidentiality	
			Dissemination Control	
			Integrity	
			Accountability	Security
			Protection (Type, Name, Duration)	
			Classification	
			Classification Caveat	

Figure F.1 OV-3 Operational Information Exchange Matrix 1

6	5	4	Row ID	
Navigation Data	Communicate with Local Strike Assets	Communicate with Local Strike Assets	Needline Identifier	
Navigation Information	BDI Request	BDI Feedback	Information Exchange Identifier	
Navigation Data	Tasking	Fused Target Information	Information Element Name	Information Element Description
Satellite PRNs and Navigation Messages	Type of BDI needed, last known enemy positions, time/status of strike, and type of strike	BDI Confirmation and general ISR information gathered	Content	
Any information being transmitted by the GPS satellites	Includes any information that can be provided by the Strike Asset to enable an effective BDI mission	Any communication with Strike Assets	Scope	
Determined by external node	User needs to receive request	Strike Asset should understand feedback	Accuracy	
			Language	
GPS Satellites	Strike Assets	Friendly Ground Unit	Sending Op Node Name	Producer
Provide GPS System (A-1)	Provide Strike Assets (A-4)	Process Information (A11)	Sending Op Activity Name & ID	
MAV	Friendly Ground Unit	Strike Assets	Receiving Op Node Name	Consumer
Provides Flight Controls (A31)	Process Information (A11)	Provides Strike Assets (A-4)	Receiving Op Activity Name & ID	
AFT 3.1 Provide Information Operations Capabilities	AFT 3.1 Provide Information Operations Capabilities	AFT 3.1 Provide Information Operations Capabilities	Mission/Scenario UJTL, METL, or AFTL	Nature of Transaction
Data Transmission	Voice Transmission	Voice Transmission	Transaction Type	
Determined by external node	Strike Asset cannot perform BDI therefore request a BDI mission	User needs to communicate to Strike Assets	Triggering Event	
Level 1 Connected (Peer-to-Peer)	Level 0 Isolated (Manual)	Level 0 Isolated (Manual)	Interoperability Level Required (from C4ISR WG)	
Mission Essential	Mission Essential	Can increase mission effectiveness	Criticality	
PRNs and Navigation message always being transmitted	Does not occur often however it depends on the battlefield situation	Does not occur often however it depends on the battlefield situation	Periodicity	Performance Attributes
Processing time depends on receiver (in seconds)	Depends on method of delivery (in minutes)	Depends on method of delivery (in minutes)	Timeliness	
			Access Control	Information Assurance
			Availability	
			Confidentiality	
			Dissemination Control	
			Integrity	
			Accountability	Security
			Protection (Type, Name, Duration)	
			Classification	
			Classification Caveat	

Figure F.2 OV-3 Operational Information Exchange Matrix 2

9	8	7	Row ID	
Platform Communication	Platform Communication	Platform Communication	Needline Identifier	
Platform Launch	ISR Data	Flight Status Data	Information Exchange Identifier	
User Commands (Successful Launch)	Raw Sensor Package Data	Raw Flight Telemetry Data	Information Element Name	Information Element Description
Physical Interaction resulting in successful launch	Sensor Feedback (Video)	Platform Status (current position, remaining power)	Content	
Any actions involving the platform launch sequence	Data collected by the sensor package	Information that would be helpful to the user concerning the platform	Scope	
Platform is calibrated correctly and launch is successful	Very Accurate such that sensor resolution is not effected	Accurate enough such that the user has a feel for the platforms status	Accuracy	
			Language	
Friendly Ground Unit	MAV	MAV	Sending Op Node Name	Producer
Launch MAV (A24)	Enables Sensor Package (A33)	Provides Flight Controls (A31)	Sending Op Activity Name & ID	
MAV	Friendly Ground Unit	Friendly Ground Unit	Receiving Op Node Name	Consumer
Provides Flight Controls (A31)	Provides Vehicle Control and Communication (A12)	Provides Vehicle Control and Communication (A12)	Receiving Op Activity Name & ID	
AFT 3.1 Provide Information Operations Capabilities	AFT 3.1 Provide Information Operations Capabilities	AFT 3.1 Provide Information Operations Capabilities	Mission/Scenario UJTL, METL, or AFTL	Nature of Transaction
Physical Interaction	Data Transmission	Data Transmission	Transaction Type	
Launch Platform	Sensor receives information	Platform senses change in flight or system status	Triggering Event	
Level 0 Isolated (Manual)	Level 1 Connected (Peer-to-Peer)	Level 1 Connected (Peer-to-Peer)	Interoperability Level Required (from C4ISR WG)	
Mission Essential	Mission Essential	Needed to ensure Mission effectiveness	Criticality	Performance Attributes
Launch varies by mission	Occurs whenever sensor is enabled (very often)	Occurs whenever platform status has changed	Periodicity	
Launch in minutes	Varies by Separation Distance, User Reaction, and Command Processing (in seconds)	Varies by Separation Distance, User Reaction, and Command Processing (in seconds)	Timeliness	
			Access Control	Information Assurance
			Availability	
			Confidentiality	
			Dissemination Control	
			Integrity	Security
			Accountability	
			Protection (Type, Name, Duration)	
			Classification	
			Classification Caveat	

Figure F.3 OV-3 Operational Information Exchange Matrix 3

12 Platform Communication	11 Platform Communication	10 Platform Communication	Row ID	
Request or Command Information	Platform Recovery	Platform Maintenance	Needline Identifier	Information Exchange Identifier
User Commands	User Commands (MAV Landed)	System Status (Ground Station Fault, MAV Launch Fault, Airframe Fault, Landing Fault)	Information Element Name	Information Element Description
Air Platform Control and Flight Profile Information	Physical Interaction resulting in successful recovery	Physical Interaction involving platform maintenance	Content	
Data used to control the air platform	Any actions involving the platform recovery sequence	Anytime the user needs to physically interact with the platform for maintenance	Scope	
Platform should obey commands	Platform is instructed to land and recovery is possible	Platform should be constructed such that the user can accurately interact with it	Accuracy	
			Language	
Friendly Ground Unit	Friendly Ground Unit	Friendly Ground Unit	Sending Op Node Name	Producer
Provides Vehicle Control and Communication (A12)	Fly to Landing Zone (A41)	Provides Information Processing (A1), Enable Launch MAV (A2), Provides ISR MAV Platform (A3), Enable Land/Recover MAV (A4)	Sending Op Activity Name & ID	
MAV	MAV	MAV	Receiving Op Node Name	Consumer
Enable Launch MAV (A2), Provides ISR MAV Platform (A3), Enable Land/Recover MAV (A4)	Recover MAV (A42)	Provide Field Level Maintenance (A5)	Receiving Op Activity Name & ID	
AFT 3.1 Provide Information Operations Capabilities	AFT 3.1 Provide Information Operations Capabilities	AFT 3.1 Provide Information Operations Capabilities	Mission/Scenario UJTL, METL, or AFTL	Nature of Transaction
Data Transmission	Physical Interaction	Physical Interaction	Transaction Type	
User wishes to create or modify flight profile	Recover Platform	Platform Maintenance	Triggering Event	
Level 1 Connected (Peer-to-Peer)	Level 0 Isolated (Manual)	Level 0 Isolated (Manual)	Interoperability Level Required (from C4ISR WG)	
Mission Essential	Mission Essential	Mission Essential	Criticality	Performance Attributes
Varies by User	Recover varies by mission	Maintenance should only occur if required	Periodicity	
Varies by Separation Distance, User Reaction, and Command Processing (in seconds)	Recover in minutes	Maintain in minutes	Timeliness	
			Access Control	Information Assurance
			Availability	
			Confidentiality	
			Dissemination Control	
			Integrity	
			Accountability	Security
			Protection (Type, Name, Duration)	
			Classification	
			Classification Caveat	

Figure F.4 OV-3 Operational Information Exchange Matrix 4

14	13	Row ID	
System Maintenance Needed / Request	System Maintenance Needed / Request	Needline Identifier	
Maintenance Request	Completed Maintenance Request	Information Exchange Identifier	
System Status (Repairs Required)	System Status (Operational MAVs)	Information Element Name	Information Element Description
Request for maintenance to be performed on the system	Acknowledgement of completed maintenance	Content	
All maintenance that cannot be performed in the field	Any for of assurance that maintenance has been performed	Scope	
Maintenance Depot should receive request	User notified on status of maintenance	Accuracy	
		Language	
Friendly Ground Unit	Maintenance Depot	Sending Op Node Name	Producer
Provide ISR Capabilities (A0)	Provide Non-Field Level Maintenance (A-3)	Sending Op Activity Name & ID	
Maintenance Depot	Friendly Ground Unit	Receiving Op Node Name	Consumer
Provide Non-Field Level Maintenance (A-3)	Provide ISR Capabilities (A0)	Receiving Op Activity Name & ID	
AFT 3.1 Provide Information Operations Capabilities	AFT 3.1 Provide Information Operations Capabilities	Mission/Scenario UJTL, METL, or AFTL	Nature of Transaction
Voice Transmission	Voice Transmission	Transaction Type	
System needs non-field level maintenance performed	System maintenance complete	Triggering Event	
Level 0 Isolated (Manual)	Level 0 Isolated (Manual)	Interoperability Level Required (from C4ISR WG)	
Can increase mission effectiveness	Can increase mission effectiveness	Criticality	
Depends on usage and system handling	Depends on usage and system handling	Periodicity	Performance Attributes
Depends on method of delivery (in minutes)	Depends on method of delivery (in minutes)	Timeliness	
		Access Control	Information Assurance
		Availability	
		Confidentiality	
		Dissemination Control	
		Integrity	
		Accountability	Security
		Protection (Type, Name, Duration)	
		Classification	
		Classification Caveat	

Figure F.5 OV-3 Operational Information Exchange Matrix 5

Appendix G. MAV OV-4

Table G.1 – AV-2 Integrated Dictionary

Entities, Attributes, and Relationships	Description
Graphical Box Types:	Organizations
AF Materiel Command	<p>Description: This is the overarching acquisition and development command for the two main organizations, AF research labs and the UAV system program office. While there may be more levels of command between this organization and AFMC, it is represented here to show its comparison to the AF Special Operations Command level. It is responsible for the <i>cradle to grave</i> management of the MAV system (development, acquisition, sustainment, tech support, and retirement of the system). Type of Organization: Command Level Organization Views: OV-4</p>
AF Special Operations Command	<p>Description: This is the overarching special operations command that controls the user for this system. Other commands may also have users of the system (i.e. Air Combat Command), however, for this view, AFSOC will represent any and all users of the system. It is responsible for training, supporting, and directing its materiel towards the goals of the combatant commanders in the realm of special operations. Type of Organization: Command Level Organization Views: OV-4</p>
AF Research Lab or Munitions Directorate	<p>Description: This organization is in directorate level control of the developing offices and teams of the MAV. It is states as either an AF Research Lab or Munitions Directorate because the intuitive choice of an AF Research Lab is not the only possible case. It is responsible for managing its programs and offices within its given budget, constraints and directives toward the goals of developing new and emerging technology.</p>
Continued on next page	

Table G.1 – continued from previous page

Entities, Attributes, and Relationships	Description
	<p>Type of Organization: Directorate Level Organization Views: OV-4</p>
UAV System Program Office	<p>Description: This organization is either a dedicated System Program Office (SPO) for Unmanned Aerial Vehicles (UAV) or is the Basket SPO that would control the MAV system. It is responsible for the Operational Safety, Suitability, and Effectiveness (OSS&E) of all UAV systems under its control. Type of Organization: Directorate Level Organization Views: OV-4</p>
MAV Lab	<p>Description: This organization is responsible for the actual development of the MAV system and its capabilities. After technology development and demonstration, it will transition it to the MAV SPO. It is responsible for the Operational Safety, Suitability, and Effectiveness (OSS&E) of the MAV system. Type of Organization: Division Level Organization Views: OV-4</p>
MAV System Program Office	<p>Description: This organization is responsible for the Operational Safety, Suitability, and Effectiveness (OSS&E) of the MAV system. It is the <i>single face to the user</i> that handles new acquisition of the system, its parts, any technical support issues from the user, modifications, and maintenance plans/directives on the system. Type of Organization: Directorate or Division Level Organization Views: OV-4</p>
Mission Support	<p>Description: This organization is responsible for training, equipping, and supporting the special operation forces to enable them to perform their missions. They will maintain the MAV systems, beyond field repair requirements. They will act as the user representative to the SPO on any technical issues regarding the MAV inventory.</p>
Continued on next page	

Table G.1 – continued from previous page

Entities, Attributes, and Relationships	Description
	Type of Organization: Directorate Level Organization Views: OV-4
Operations	Description: This organization is responsible for directing the special operations forces in completing their missions. Its main responsibility is to execute their directed missions from the combatant commanders. This organization is represented as the Local Commander/ Headquarters on the OV-2 diagram. Type of Organization: Directorate Level Organization Views: OV-4
Engineering	Description: This organization is responsible for the technical aspects of the system. In the MAV Lab hierarchy it is responsible for the research, design, integration, and test of the system. In the SPO hierarchy it is responsible for the technical orders, modifications, and technical issues related to the MAV. It will likely have a chief engineering who will be the primary advisor the parent organizations chief officer on any OSS&E issues. Type of Organization: Branch Level Organization Views: OV-4
Program Management	Description: This organization is responsible for all management aspects of the system. In both the MAV Lab and SPO this organization manages planning, programming, and budgeting of the system. It also manages the acquisition cycle aspects of the system. Type of Organization: Branch Level Organization Views: OV-4
Continued on next page	

Table G.1 – continued from previous page

Entities, Attributes, and Relationships	Description
Flight Systems	<p>Description: This organization is responsible for the MAV flight systems. Specifically it is responsible for the aircraft portion of the system. In the MAV Lab this organization develops and demonstrates designs for the aircraft. In the SPO this organization handles any issues related to the fielded aircraft (T.O. changes, field questions, modifications). Type of Organization: Section Level Organization Views: OV-4</p>
Ground Systems	<p>Description: This organization is responsible for the MAV ground systems. Specifically it is responsible for the portion of the system that remains on the ground during operation. In the MAV Lab this organization develops and demonstrates designs for the ground systems. In the SPO this organization handles any issues related to the fielded ground system (T.O. changes, field questions, modifications). Type of Organization: Section Level Organization Views: OV-4</p>
Sensor Systems	<p>Description: This organization is responsible for the MAV sensor systems. Specifically it is responsible for the various sensor capabilities used by the MAV system. In the MAV Lab this organization develops and demonstrates designs for various sensors. In the SPO this organization handles any issues related to the fielded sensors (T.O. changes, field questions, modifications). Type of Organization: Section Level Organization Views: OV-4</p>
Continued on next page	

Table G.1 – continued from previous page

Entities, Attributes, and Relationships	Description
Integration Section	<p>Description: This organization works with the members of the flight systems, ground system, and sensor systems sections to produce an integrated, testable design for demonstration. This organization likely relies on system engineering principles and products. As an alternative to this organization, an integrated team of the mentioned sections with a single human role of systems engineer could potentially serve the same function.</p> <p>Type of Organization: Section Level Organization Views: OV-4</p>
Test Section	<p>Description: This organization works with all of the sections to test and evaluate a full MAV design for technology demonstration. Following successful test and evaluation, the designs may or may not be transitioned to the SPO for full system production.</p> <p>Type of Organization: Section Level Organization Views: OV-4</p>
Research Section	<p>Description: This organization is responsible for research related to new or emerging technology related to the MAV system. It works to integrate findings from that research into actionable technology for use by the other sections.</p> <p>Type of Organization: Section Level Organization Views: OV-4</p>
Academic Institutions	<p>Description: These organizations operate under research grants to develop new and emerging technology as directed through the research section of the MAV lab. Their findings are then transitioned into useful technology for inclusion in MAV system design.</p> <p>Type of Organization: Consultant Organization Views: OV-4</p>

Continued on next page

Table G.1 – continued from previous page

Entities, Attributes, and Relationships	Description
Contractor Support	<p>Description: This organization can be of any size or level. It is responsible for performing its contractual obligations to the government in support of the office it has been contracted to. Various contracts can be performed. Research contracts with the MAV Lab seek to develop technology or integrate existing designs to produce initial design units for demonstration. Production contracts with the SPO seek to simply produce already designed systems for fielding.</p> <p>Type of Organization: Consultant Organization Views: OV-4</p>
Logistics Management	<p>Description: This organization is responsible for the logistical support required to keep the MAV systems in inventory operational. It acquires, maintains, and distributes parts as needed to keep the MAVs operational.</p> <p>Type of Organization: Branch Level Organization Views: OV-4</p>
Field Teams	<p>Description: These organizations are the actual operators of the MAV System. They are organized by mission, but typically are between 1 and 10 members. They combine with the ground system of the MAV to represent the Friendly Ground Unit as displayed in the OV-2 diagram.</p> <p>Type of Organization: Section Level Views: OV-4</p>
Development Team	<p>Description: This organization is the combined team of all member organizations required to develop the MAV system. It includes all members of the MAV lab as well as representation from the Academic Institution and Contractor Support.</p> <p>Type of Organization: Integrated Team Views: OV-4</p>
Continued on next page	

Table G.1 – continued from previous page

Entities, Attributes, and Relationships	Description
SPO Team	<p>Description: This organization is the combined team of all member organizations required to perform the role of SPO for the MAV system. It includes all members of the MAV SPO as well as representation from Contractor Support.</p> <p>Type of Organization: Integrated Team</p> <p>Views: OV-4</p>
Graphical Arrow Types:	Organizational Relationships
Command Relationships	<p>Description: These relationships are represented by solid lines connecting organizations. They represent command between the higher organization and its sub-organizations. It implies reporting responsibility, budgetary roll-up, and other considerations regarding a chain of command.</p> <p>Type: Hierarchical</p>
Technology Transition / Spiral Feedback	<p>Description: This relationship represents the MAV Lab in general transitions the technology to the MAV SPO. It also represents that in general the MAV SPO will provide feedback for future spirals of the existing design to help focus efforts of the MAV Lab.</p> <p>Type: General Responsibilities</p> <p>Organizations: MAV Lab and MAV SPO</p>
Sustainment / Spiral Feedback	<p>Description: This relationship represents the MAV SPO in general is responsible for sustaining the MAV system to the Mission Support. In return, Mission Support will provide feedback to the MAV SPO for future design spirals.</p> <p>Type: General Responsibilities</p> <p>Organizations: MAV SPO and Mission Support</p>
Program Interface	<p>Description: The relationship shows the communication link between the two program management organizations. While there will likely be more inter-sectional communication between the MAV Lab and the MAV SPO, the Program Management organizations will have an formal communication regarding documented milestones, requirements, etc.</p>
Continued on next page	

Table G.1 – continued from previous page

Entities, Attributes, and Relationships	Description
	<p>Type: Communication Organizations: Program Management (MAV Lab) and Program Management (MAV SPO)</p>
<p>Research Contracts</p>	<p>Description: This relationship represents the contractual responsibility of the Contractor Support to the Program Management (MAV Lab) to work on a research related contract. Type: Under Contract Organizations: Program Management (MAV Lab) and Contractor Support</p>
<p>Research Grants</p>	<p>Description: This relationship represents the contractual responsibility of the Academic Institution to the Research Section to work under a research grant. Type: Under Contract Organizations: Research Section and Academic Institutions</p>
<p>Production Contracts</p>	<p>Description: This relationship represents the contractual responsibility of the Contractor Support to the Program Management (MAV SPO) to work on a production related contract. Type: Under Contract Organizations: Program Management (MAV SPO) and Contractor Support</p>
<p>Tech Support</p>	<p>Description: This relationship is the act of the operators working through Mission Support to request clarification on issues regarding the MAV system. Mission Support would use this communication to seek help on T.O. questions, maintenance deviations, etc. Type: Communication Organizations: SPO Team and Mission Support</p>
<p>Supply / Equip</p>	<p>Description: This relationship is the act of the Mission Support Organization providing operationally ready MAV systems to the operators and re-supplying or repairing those systems as needed. Type: Physical Interface</p>
Continued on next page	

Table G.1 – continued from previous page

Entities, Attributes, and Relationships	Description
	Organizations: Mission Support and Field Teams

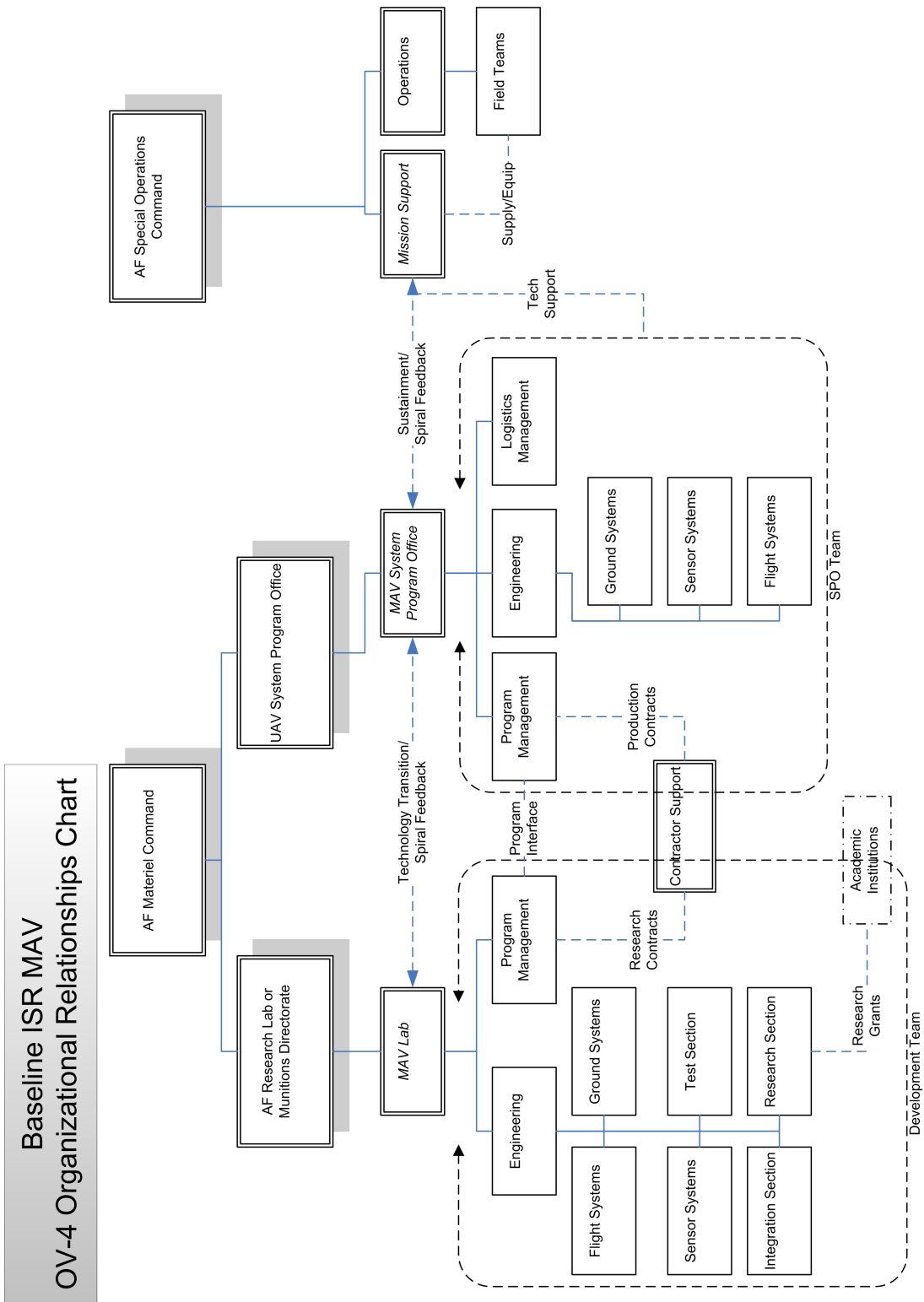

Figure G.1 OV-4 Organizational Relationships Diagram

Appendix H. MAV OV-5

Table H.1 – Functional Entities

Data Elements		Example Values/Explanation
Graphical Box Types	ID	
Calibrate MAV	(Block A22)	Set home position for MAV and ensure all onboard navigation systems are getting or sending correct information.
Enable Land/Recover MAV	(Block A4)	Similar to Enable Launch MAV where the system receives the updated mission profile, flies to the landing zone and performs the landing sequence. The last action is by the user when the MAV is physically picked up and inspected for damage before returning to service.
Enable Launch MAV	(Block A2)	All activities pertaining to providing the MAV with a mission and setting it on that mission. This includes the functions of initialization by the operator, calibrating the navigation systems, uploading the mission, and physically launching the MAV.
Enables Sensor Package	(Block A33)	Ensures that the desired sensor packages can be carried onboard. This refers mainly to fuselage space, cooling, powering the sensor, etc.
Fly to Landing Zone	(Block A42)	The MAV will fly to the landing zone directed by the landing instructions.
Initialize MAV	(Block A21)	Power on the MAV and make sure all connections are functioning.
Launch MAV	(Block A24)	Power on the propulsion system and physically throw the MAV.
Process Information	(Block A11)	Refers to both the hardware processing via laptop or other device as well as the human user making decisions based on the gathered information
Provide Command and Control	(Block A-2)	The function performed by headquarters or similar official body.
Continued on next page		

Table H.1 – continued from previous page

Graphical Box Types	ID	
Provide Field Level Maintenance	(Block A5)	This encompasses any field level repairs done to the MAV either before or after the mission including, but not limited to: changing batteries, changing/repairing wings, swapping out sensor packages, changing/repair propellers, etc.
Provide GPS System	(Block A-1)	The navigation data coming from the GPS satellites.
Provide ISR Capabilities	(Block A0)	The main purpose of the system is to provide an extension to the tools the SOF teams already employ in the field.
Provide Non Field-Level Maintenance	(Block A-3)	Any maintenance on the MAV which cannot be performed in the field, i.e. repairing the fuselage or sensor packages.
Provide Strike Assets	(Block A-4)	The information provided by the MAV will be used to direct strike missions by the strike assets.
Provides Flight Controls	(Block A31)	Autopilot and all relevant sensor hardware required for autonomous or remotely piloted control of the MAV.
Provides Flight Vehicle	(Block A32)	Refers to the physical air platform which is capable of carrying the sensor package, navigation systems, propulsion and batteries necessary for mission execution.
Provides ISR MAV Platform	(Block A3)	The other main function of this system is to provide a usable MAV considering form, fit and function as it relates to carriage and operation in a mission scenario.
Provides Vehicle Control and Communication	(Block A12)	This can be considered to be the functions provided by the ground station radio. The data from the MAV is decoded and sent to the users computer or display from here. Also, the flight plan is sent from the users input system to the MAV via the hardware and communication methods designed into the system.
Recover MAV	(Block A44)	The user physically picks up the MAV and inspects it for damage.
Upload Mission Profile	(Block A23)	The operator sends the desired mission profile to the MAV.

Table H.2 – Activity Diagram ICOMs

Data Elements			Example Values/Explanation
Graphical Arrow Types	Origin	Destination	
Actuator Commands	A31	A32	The communication between the flight control computer/autopilot system and the actuators or servos.
Airframe Fault	A3	A5	Generic error reported to the user comprising of any or all of the following: flight control fault, flight vehicle fault, and sensor package fault.
Calibration Fault	A22	A5	This fault consists of the navigation system being unable to acquire sufficient satellite coverage to determine its current position. The fault can also refer to a failure of the relative positional sensors or a failure of the flight control system.
Decoded Flight Telemetry	A12	A12	The flight telemetry data after it passes through the ground communication suite.
Decoded Sensor Package Data	A12	A11	The sensor package data after it passes through the ground communication suite.
Flight Control Fault	A31	A5	A failure in the flight control system. Includes failures of flight control computer, servos or attachments to flight control surfaces.
Flight Control Feedback	A32	A31	Feedback from the flight path monitoring hardware (i.e. gyros, accelerometers, GPS receiver) to the navigation computer.
Flight Fault	A41	A5	Refers to any error encountered after the landing zone coordinates are given to the MAV.
Flight Plan	A11	A12	The waypoints or mission profile sent from the user to the autopilot.
Flight Rules or Airspace Deconfliction	N/A	A1	Any external limitations such as weather, terrain or the local airspace condition which would affect the usage or flight plan of the system.
Continued on next page			

Table H.2 – continued from previous page

Graphical Arrow Types	Origin	Destination	
Flight Vehicle Fault	A32	A5	Failure in the structure of the flight vehicle. Can result from impact with foreign airborne objects or material / construction defects of the MAV.
Fused Target Information	A11	A-2	The processed information gathered from the MAV and sent back to headquarters or decision making authority for further processing or action.
Fused Target Information	A11	A-4	Any processed information requiring action from a strike asset.
Ground Station	N/A	A0 Tunneled	The communication hardware necessary to send and receive all pertinent information as well as the required hardware to display the information to the user.
Ground Station Fault	A12	A5	Any equipment failure resulting in the inability of the operator to receive, transmit or interpret information coming to or from the MAV. This includes failures in the display device, the radio equipment or ground based wiring or requisite batteries.
Human Operator	N/A	A0 Tunneled	The human user of the system responsible for system use and repair.
Initialization Fault	A21	A5	Failure of the onboard power systems or other inability to pass built-in internal test.
Land Decision	A12	A41	Either a user directed landing or mission completion resulting in the need to land.
Landing Fault	A4	A5	Generic error comprising of either a flight fault or a recovery fault.
Launch Decision	A12	A21	The decision to launch the MAV.
Launch Fault	A24	A5	Any post upload failure resulting in the MAVs inability to perform the mission. This is most likely an operator launch error due to environmental conditions.
MAV Landed	A41	A42	MAV arrives at the landing zone and the airspeed is zero.
Continued on next page			

Table H.2 – continued from previous page

Graphical Arrow Types	Origin	Destination	
MAV Launch Fault	A2	A5	Any failure resulting from the onboard systems inability to power on, be calibrated or to upload the mission profile.
Mission Operable Recovery	A42	A11	The desired state for the MAV. It has performed the mission, has landed and is prepared to be launched again.
Mission Operating Procedures	N/A	A0 Tunneled	Any specific flight or usage restrictions imposed by the particular mission.
Navigation Data	A-1	A31	GPS signal or inertial data required for the autopilot and user to know where the MAV is and where it is headed.
Operational MAVs	A-3	A0 Tunneled	These are either resupply or repaired MAVs coming from the non-field level MAV repair site.
Power On	A21	A22	All systems have power and are prepared for calibration.
Raw Flight Telemetry Data	A31	A12	Airborne communication feedback coming from the guidance system on the MAV to the ground station communication gear.
Raw Sensor Package Data	A33	A12	Airborne communication which sends the data from the sensor(s) onboard the MAV to the ground station communication gear.
Recovery Fault	A42	A5	Any fault making the MAV unrecoverable. The main source of this error would be controlled flight into terrain or impact with foreign airborne object on-route to the landing zone.
Repairs Required	A5	A-3	Systems identified as needed repairs which cannot be performed in the field.
Sensor Package Fault	A33	A5	Any fault resulting the in the inability of the sensor package to perform its purpose.
Successful Calibration	A22	A23	All flight required systems have been successfully calibrated.
Successful Launch	A24	A31	MAV is carrying out the uploaded mission.
Continued on next page			

Table H.2 – continued from previous page

Graphical Arrow Types	Origin	Destination	
Successful Upload	A23	A24	The mission profile was successfully received and interpreted by the navigation computer.
System Repair Status	A5	A11	The status of the system after some fault has been generated in the system. This information goes back to the user for operational impact determination.
Tasking	A-2	A11	Refers either to an internally or externally generated need for intelligence resulting in deployment of the MAV system.
Upload Fault	A23	A5	Any fault resulting in failure of the mission profile to be properly received or interpreted by the navigation computer.
User Commands	A12	A21	The operator readies the MAV for launch and turns on power to the onboard systems.
User Commands	A12	A22	Instructions sent to the MAV which calibrate the navigation system and/or the onboard sensor package.
User Commands	A12	A23	The user sends the autonomous mission profile to the navigation computer consisting of waypoints, altitudes, climb/dive parameters, etc.
User Commands	A12	A24	Consists of physically launching the system into the air.
User Commands	A12	A31	The user can manually control the flight path of the plane within control surface limitations.
User Commands	A12	A33	Provision allowing the user to either activate or deactivate the sensor package while in flight.
User Commands	A12	A41	Updating the mission profile with the landing zone coordinates and desired flight path to that landing zone.

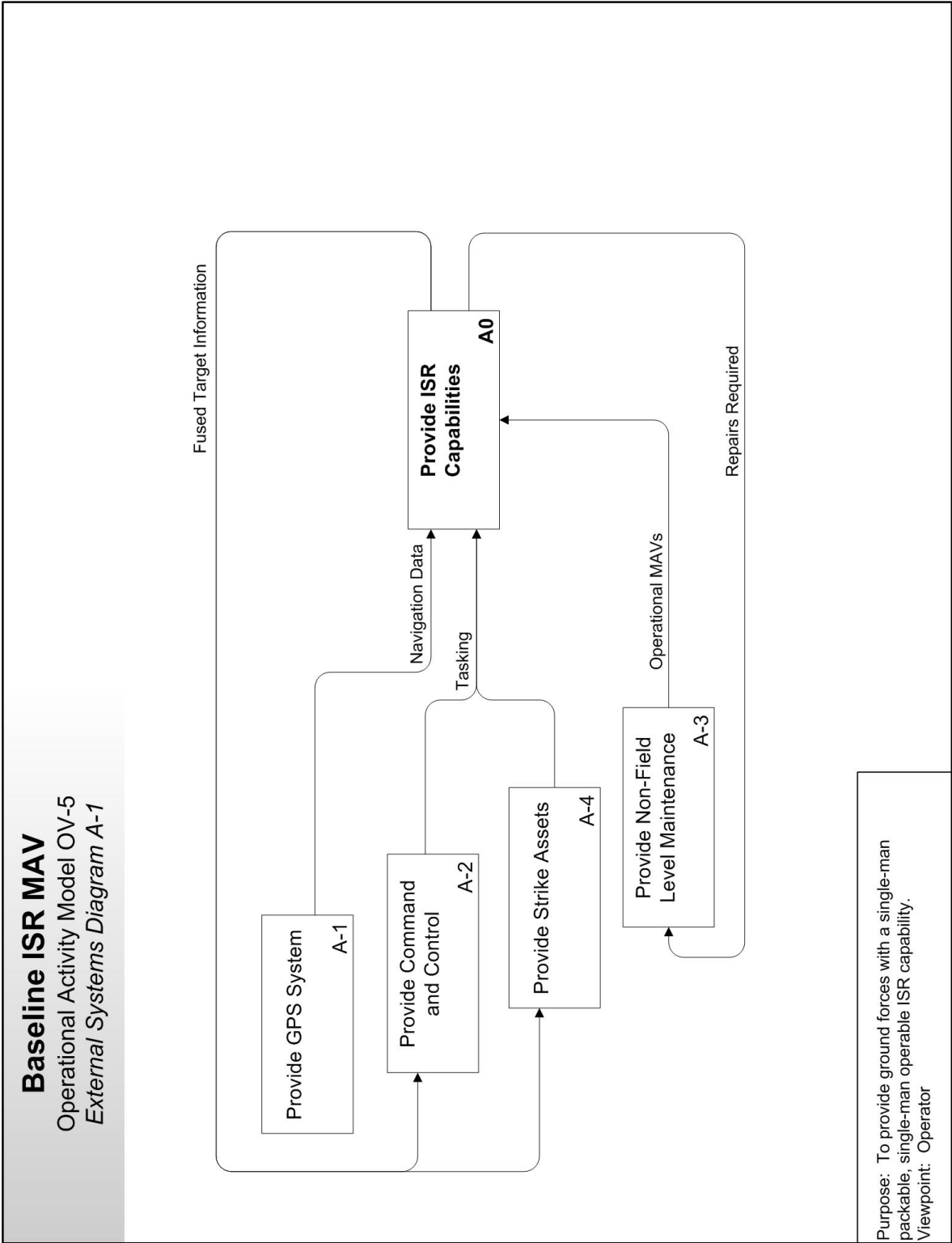

Figure H.1 OV-5 External System Diagram

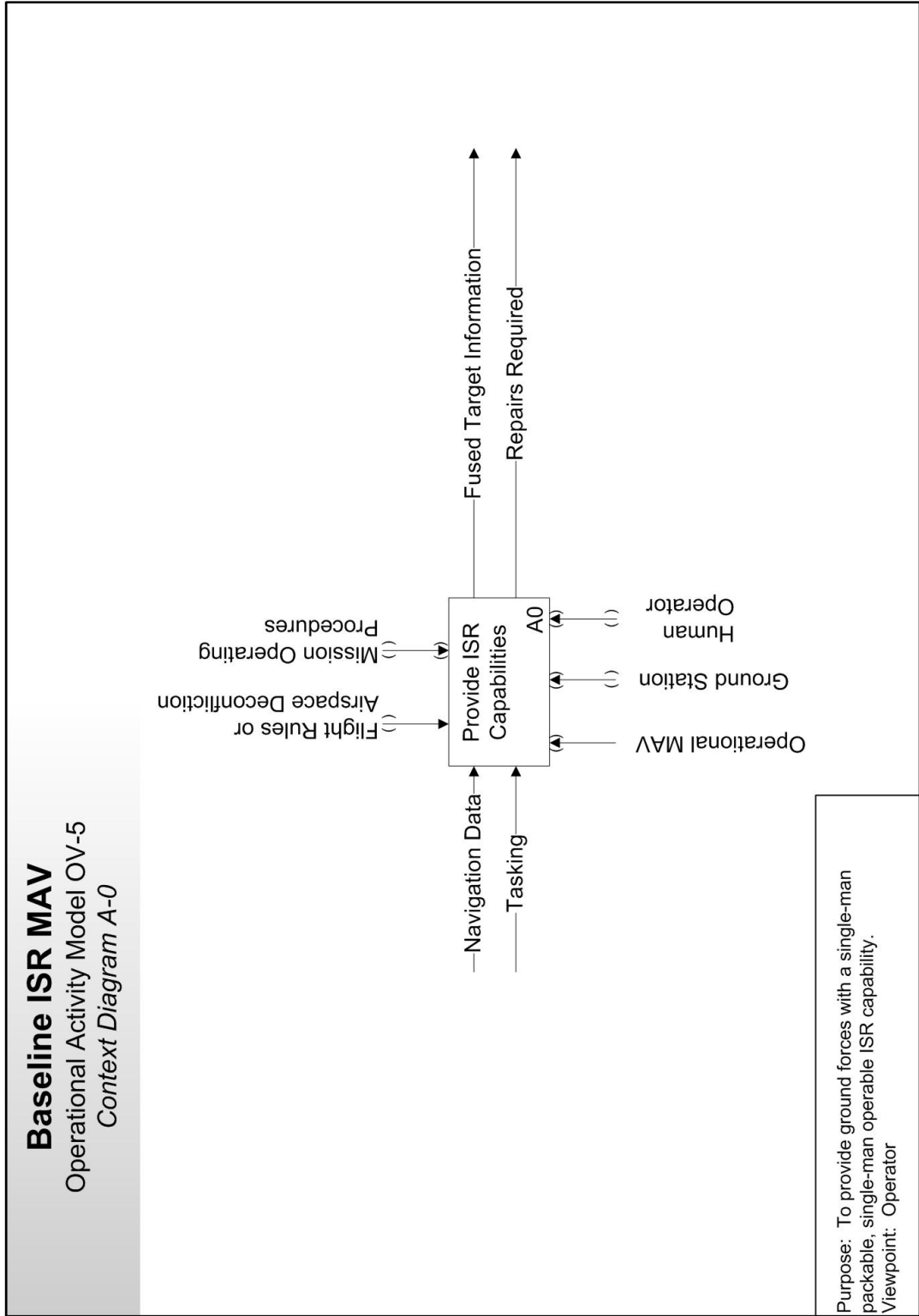

Figure H.2 OV-5 Context Diagram

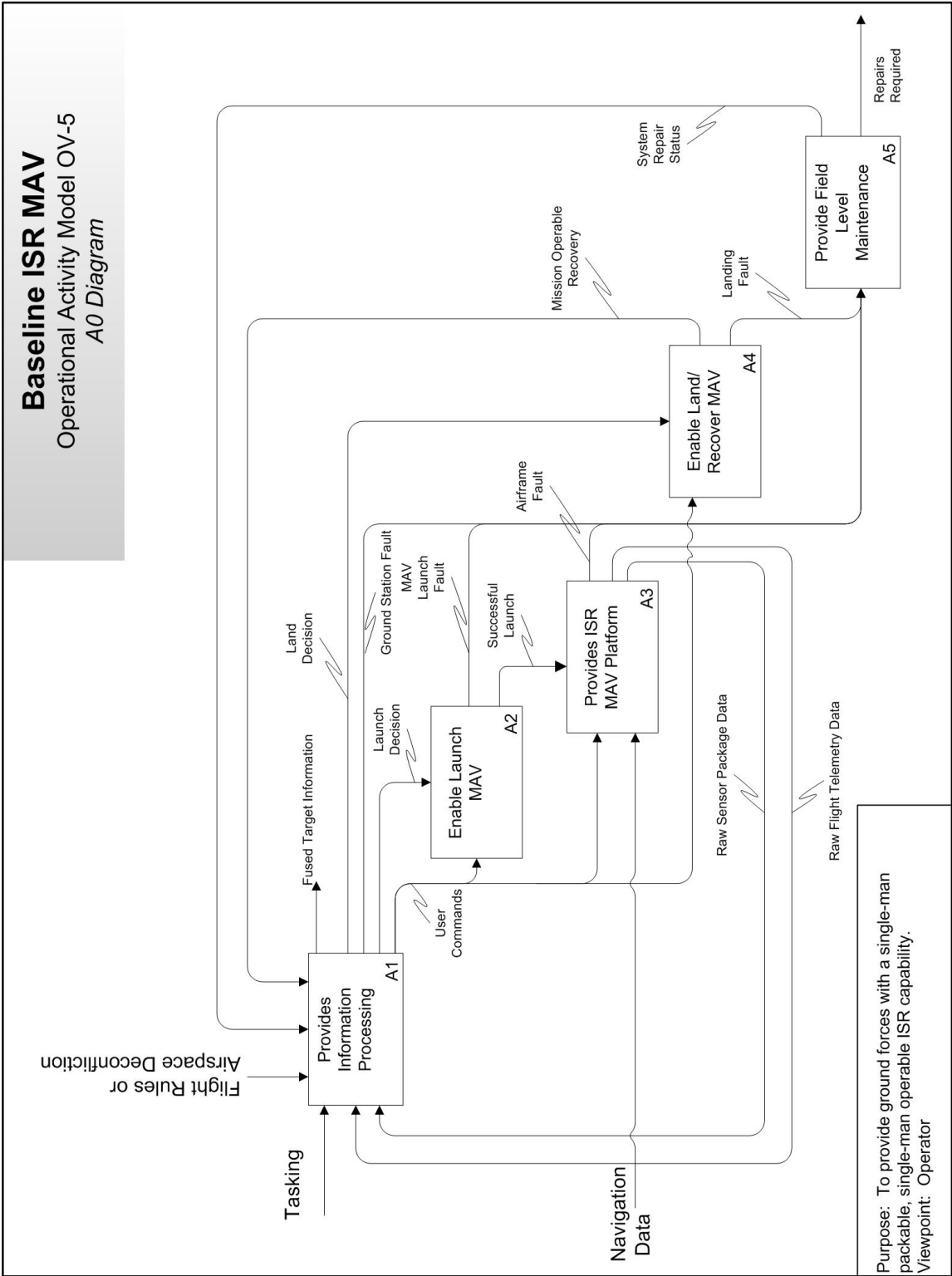

Figure H.3 OV-5 Initial Decomposition

Baseline ISR MAV

Operational Activity Model OV-5

A1 Diagram

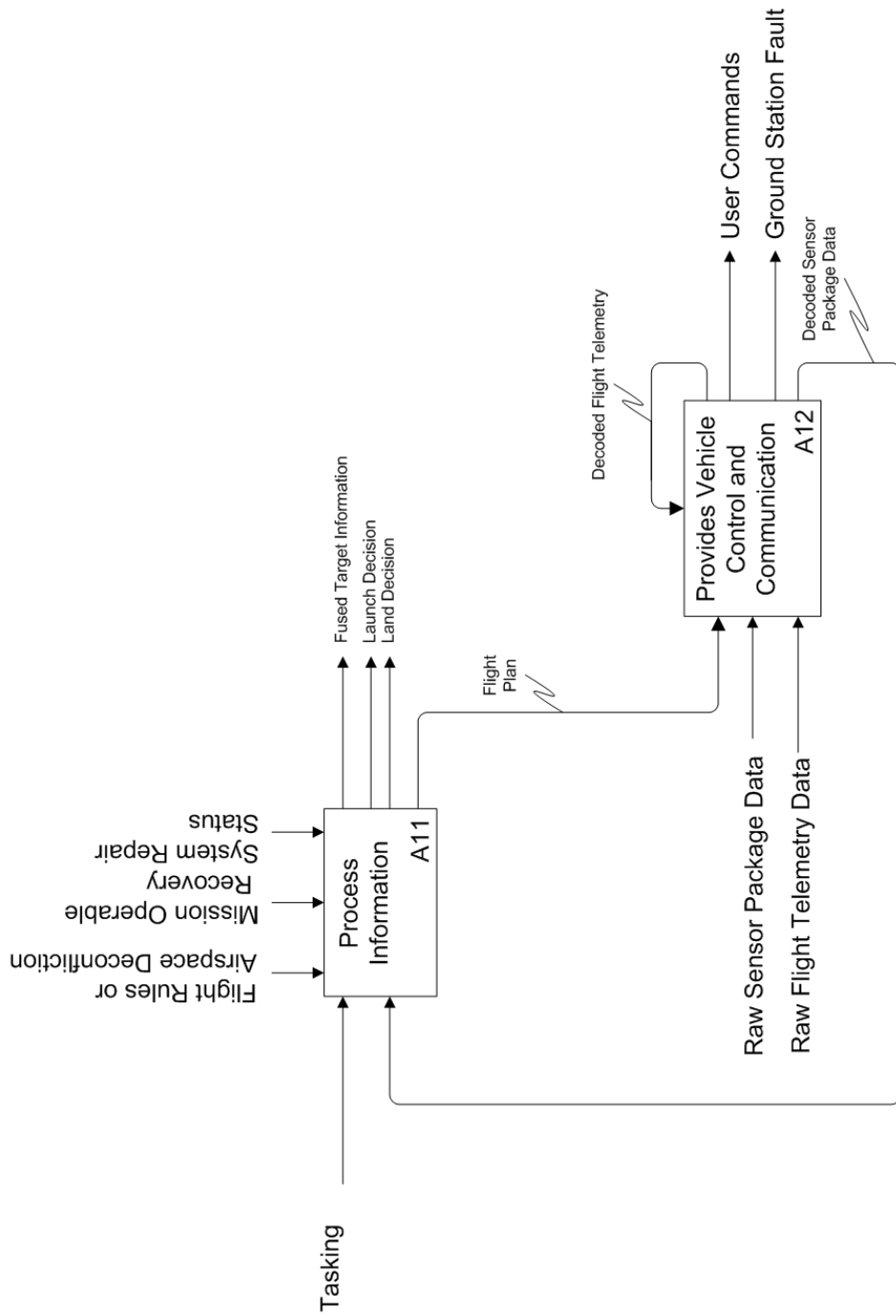

Figure H.4 OV-5 Provide Information Processing

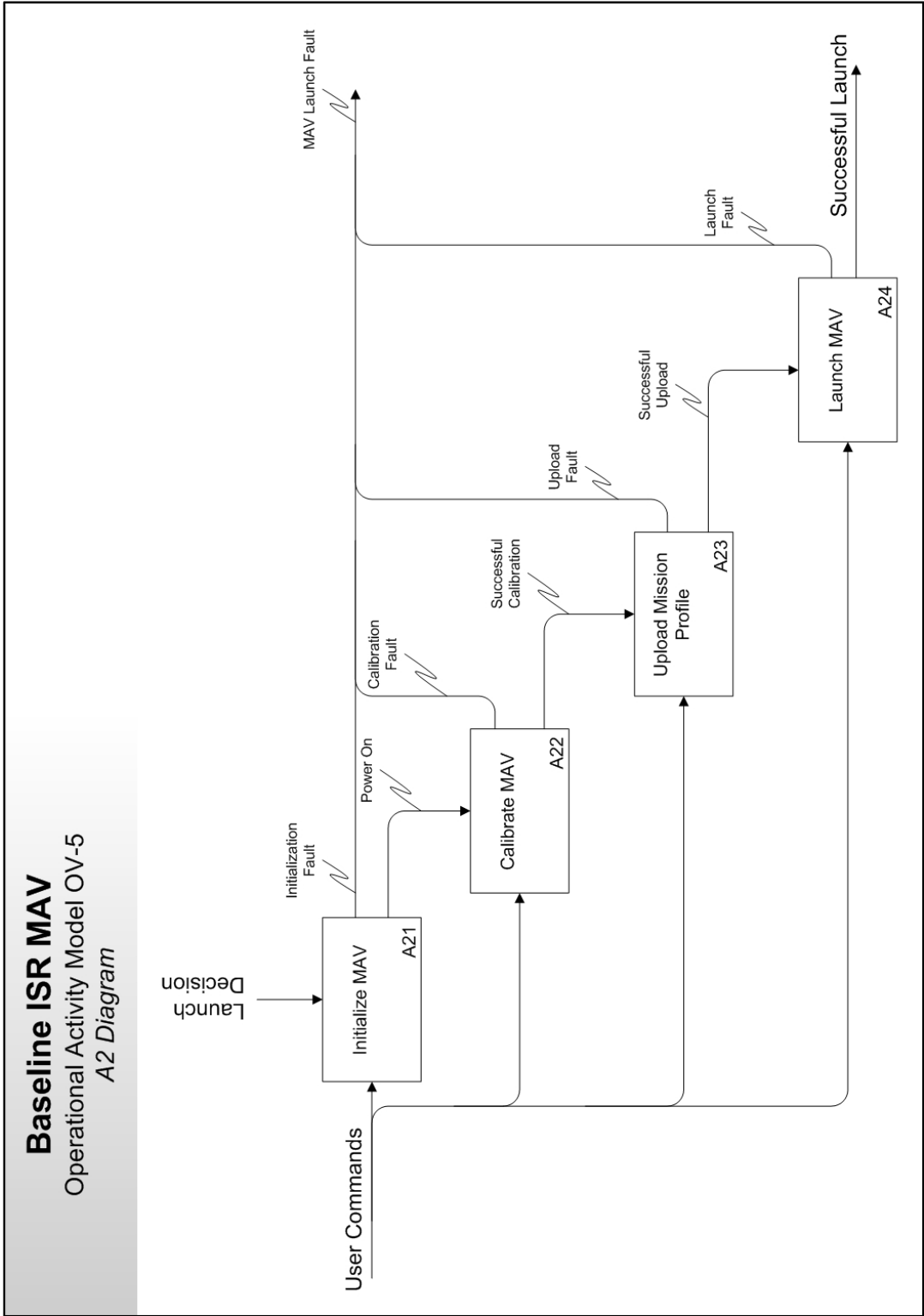

Figure H.5 OV-5 Enable Launch MAV

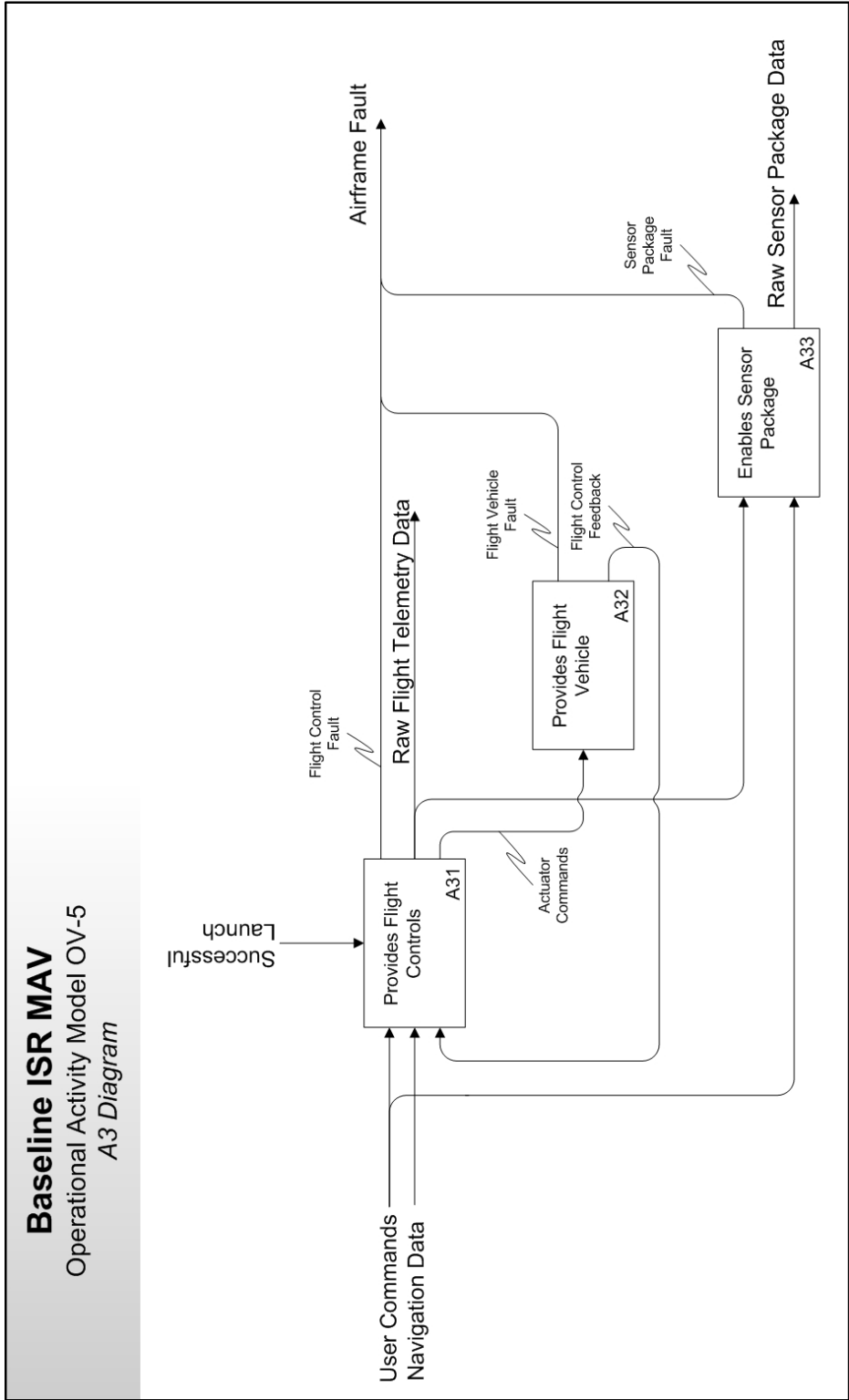

Figure H.6 OV-5 Provide ISR MAV Platform

Baseline ISR MAV

Operational Activity Model OV-5

A4 Diagram

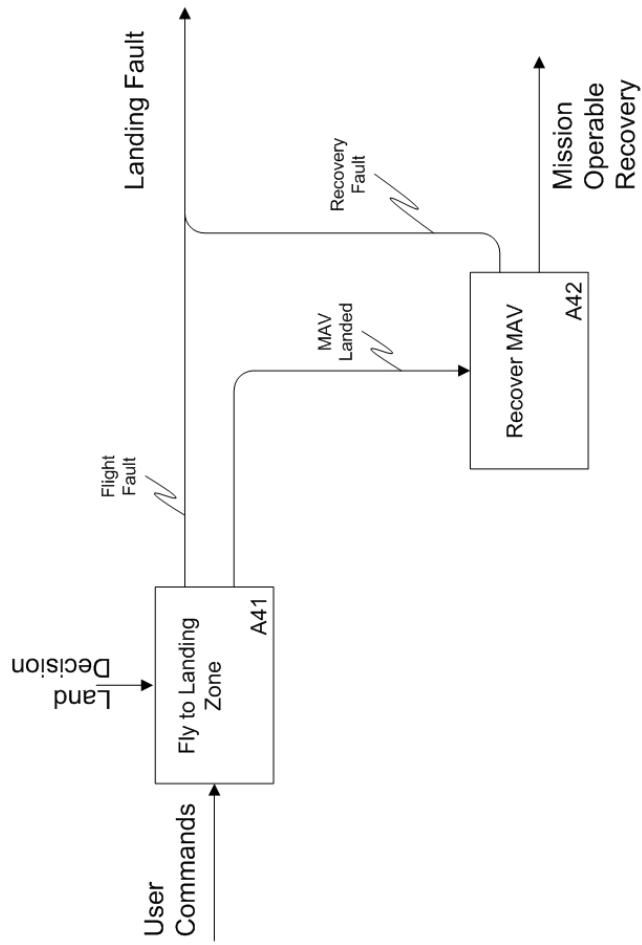

Figure H.7 OV-5 Enable Land/Recover MAV

Appendix I. MAV OV-6c

Table I.1 – AV-2 Integrated Dictionary

Entities, Attributes, and Relationships	Description
Graphical Box Types:	Swimlane/Operational Node
Friendly Ground Unit	Description: See OV-2 Operational Node Description Concept Graphics. Type: Swimlane/ Operational Node Views: OV-1, OV-2, OV-5, OV-6c, SV-1b
MAV	Description: See OV-1 High-Level Operational Concept Graphics. Type: Swimlane/ Operational Node Views: OV-1, OV-2, OV-5, OV-6c, SV-1b
Local Commander/Headquarters	Description: See OV-2 Operational Node Description. Type: Swimlane/ Operational Node Views: OV-1, OV-2, OV-5, OV-6c, SV-1b
GPS Satellites	Description: See OV-1 High-Level Operational Concept Graphics. Type: Swimlane/ Operational Node Views: OV-1, OV-2, OV-5, OV-6c, SV-1b
Strike Assets	Description: See OV-1 High-Level Operational Concept Graphics. Type: Swimlane/ Operational Node Views: OV-1, OV-2, OV-5, OV-6c, SV-1b
Graphical Box Types:	Unit of Behavior/Action
Direct Mission	Description: This action is the initiating action of the sequence. A mission for the <i>Friendly Ground Unit</i> is assigned and communicated to it. It occurs in the external system <i>Local Commander/Headquarters</i> . Type: Unit of Behavior/ Action Reference ID: 1.1 OV-5 Reference: A-2 Views: OV-6c
Decision to Launch MAV	Description: This action can take place once a mission has been assigned. It is the act of deciding to employ the MAV system to complete all or part of the mission. The <i>Friendly Ground Unit</i> performs this action.
Continued on next page	

Table I.1 – continued from previous page

Entities, Attributes, and Relationships	Description
	Type: Unit of Behavior/ Action Reference ID: 1.2 OV-5 Reference: A11 Views: OV-6c
Receive GPS Signals	Description: This action receives the GPS signals sent by satellites, converts them into useable navigation data, and determines the location of the MAV respectively. This action is performed by the <i>MAV</i> . Type: Unit of Behavior/ Action Reference ID: 1.3 OV-5 Reference: A31 Views: OV-6c
Send GPS Signal	Description: This action sends GPS signals to the MAV for use in navigation. The external system <i>GPS Satellites</i> performs this action. In this architecture it is assumed that the action of <i>Send GPS Signals</i> is occurring and continues to occur in a sufficient manner to allow for proper navigation by the MAV. Type: Unit of Behavior/ Action Reference ID: 1.4 OV-5 Reference: A-1 Views: OV-6c
Initialize System	Description: This action is a combination of the following tasks: 1) unpack and setup all components of the MAV system to include the ground station, user interface, MAV, etc., 2) program initial flight plan if necessary, and 3) calibrate the MAV. While the first action is temporally necessary before the other two, the latter two actions can occur independent of each other. All of the actions are the responsibility of the <i>Friendly Ground Unit</i> . Type: Unit of Behavior/ Action Reference ID: 1.5 OV-5 Reference: A21 Views: OV-6c
Continued on next page	

Table I.1 – continued from previous page

Entities, Attributes, and Relationships	Description
MAV Ready for Launch	<p>Description: This action is a systems check and confirmation of operationally ready status of the MAV. This action notifies the <i>Friendly Ground Unit</i> that the MAV is ready for launch. It is in response to the calibrate function within the previous <i>Initialize System</i> action. This action is the responsibility of the MAV.</p> <p>Type: Unit of Behavior/ Action</p> <p>Reference ID: 1.6</p> <p>OV-5 Reference: A2</p> <p>Views: OV-6c</p>
Launch MAV	<p>Description: This action is the physical act of lofting the MAV into the air to allow its flight systems to take over maintaining flight. It is an action that the <i>Friendly Ground Unit</i> is responsible for.</p> <p>Type: Unit of Behavior/ Action</p> <p>Reference ID: 1.7</p> <p>OV-5 Reference: A24</p> <p>Views: OV-6c</p>
Update Mission Profile	<p>Description: This action allows the friendly ground unit to either re-program a different mission profile or fly the MAV manually (i.e. real-time mission profile updating). The <i>Friendly Ground Unit</i> is responsible for this action.</p> <p>Type: Unit of Behavior/ Action</p> <p>Reference ID: 1.8</p> <p>OV-5 Reference: A23</p> <p>Views: OV-6c</p>
Continued on next page	

Table I.1 – continued from previous page

Entities, Attributes, and Relationships	Description
Perform Mission Profile	<p>Description: This action encompasses all of the actions necessary for the MAV to maintain flight in the manner set forth by the mission profile that it has been programmed with. It includes flying to set waypoints, responding to direct navigation commands (turn, climb, descend, etc.), or any other flight plan that the Friendly Ground Unit commands it to perform as allows by the rules of aerodynamics. This action is the responsibility of the <i>MAV</i>.</p> <p>Type: Unit of Behavior/ Action Reference ID: 1.9 OV-5 Reference: A3 Views: OV-6c</p>
Direct Land Sequence	<p>Description: This action is the act of the Friendly ground unit commanding the MAV system to enter into a landing sequence. It includes the initial command to land the MAV as well as any info processing and transmittal of that info to the MAV that it would require to perform the land sequence. It could be a command to return to base, land at current location, or another location as specified. This action is the responsibility of the <i>Friendly Ground Unit</i>.</p> <p>Type: Unit of Behavior/ Action Reference ID: 1.10 OV-5 Reference: A12 Views: OV-6c</p>
Receive Sensor Info	<p>Description: This action is the act of the friendly ground unit receiving sensor info sent from the MAV. It is the responsibility of the <i>Friendly Ground Unit</i>.</p> <p>Type: Unit of Behavior/ Action Reference ID: 1.11 OV-5 Reference: A12 Views: OV-6c</p>
Continued on next page	

Table I.1 – continued from previous page

Entities, Attributes, and Relationships	Description
Collect Sensor Info	<p>Description: This action is the MAV sensor system obtaining information as directed. The sensors could be many types (still camera, video camera, IR camera, NBC sniffer, etc.). It is the responsibility of the MAV to perform this act.</p> <p>Type: Unit of Behavior/ Action</p> <p>Reference ID: 1.12</p> <p>OV-5 Reference: A33</p> <p>Views: OV-6c</p>
Perform Land Sequence	<p>Description: This action is the MAV responding to the command of the friendly ground unit to land and performing that landing. It is the responsibility of the MAV.</p> <p>Type: Unit of Behavior/ Action</p> <p>Reference ID: 1.13</p> <p>OV-5 Reference: A43</p> <p>Views: OV-6c</p>
Process Info	<p>Description: This action is the friendly ground unit processing the collected sensor info from the MAV into usable ISR info. It includes image processing, data overlay (GPS coordinates, descriptors, etc), and formatting for human user interface. It is the responsibility of the <i>Friendly Ground Unit</i>.</p> <p>Type: Unit of Behavior/ Action</p> <p>Reference ID: 1.14</p> <p>OV-5 Reference: A11</p> <p>Views: OV-6c</p>
Recover MAV	<p>Description: This is the physical act of retrieving the MAV from its landing position and preparing it for either another mission or stowed transport. It is the responsibility of the <i>Friendly Ground Unit</i>.</p> <p>Type: Unit of Behavior/ Action</p> <p>Reference ID: 1.15</p> <p>OV-5 Reference: A44</p> <p>Views: OV-6c</p>
Continued on next page	

Table I.1 – continued from previous page

Entities, Attributes, and Relationships	Description
Transmit Sensor Info	<p>Description: This action is the MAV packaging and transmitting of the collected sensor info back to the friendly ground unit. It is the responsibility of the <i>MAV</i>.</p> <p>Type: Unit of Behavior/ Action Reference ID: 1.16 OV-5 Reference: A33 Views: OV-6c</p>
Transmit ISR Info	<p>Description: This action is the friendly ground unit packaging and sending the ISR info as necessary to either the Local Commander/ Headquarters or Strike Assets. The <i>Friendly Ground Unit</i> is responsible for this action.</p> <p>Type: Unit of Behavior/ Action Reference ID: 1.17 OV-5 Reference: A11 Views: OV-6c</p>
Receive ISR Info	<p>Description: This action is Local Commander/ Headquarters receiving the ISR info sent from the friendly ground unit. It is the responsibility of the external system <i>Local Commander/ Headquarters</i>.</p> <p>Type: Unit of Behavior/ Action Reference ID: 1.18 OV-5 Reference: A-2 Views: OV-6c</p>
Receive ISR Info	<p>Description: This action is the Strike Assets receiving the ISR info sent from the friendly ground unit. It is the responsibility of the external system <i>Strike Asset</i>.</p> <p>Type: Unit of Behavior/ Action Reference ID: 1.19 OV-5 Reference: A-3 Views: OV-6c</p>
Graphical Arrow Types	
Links	<p>Description: All links represent precedence between actions. All links imply that the task pointed to cannot occur until the task pointed from occurs.</p>
Continued on next page	

Table I.1 – continued from previous page

Entities, Attributes, and Relationships	Description
	Type: Temporal
Junction	<p>Description: The junction allows alternate paths to occur. The one junction that occurs in this view denotes that once <i>Launch MAV</i> has occurred, <i>Update Mission Profile</i>, <i>Direct Land Sequence</i>, or <i>Perform Mission Profile</i> can then occur. It also provides a tie-in to allow <i>Update Mission Profile</i> to affect the <i>Perform Mission Profile</i> action. In other words, manual inputs can then affect how the MAV performs its mission.</p> <p>Type: NA</p>

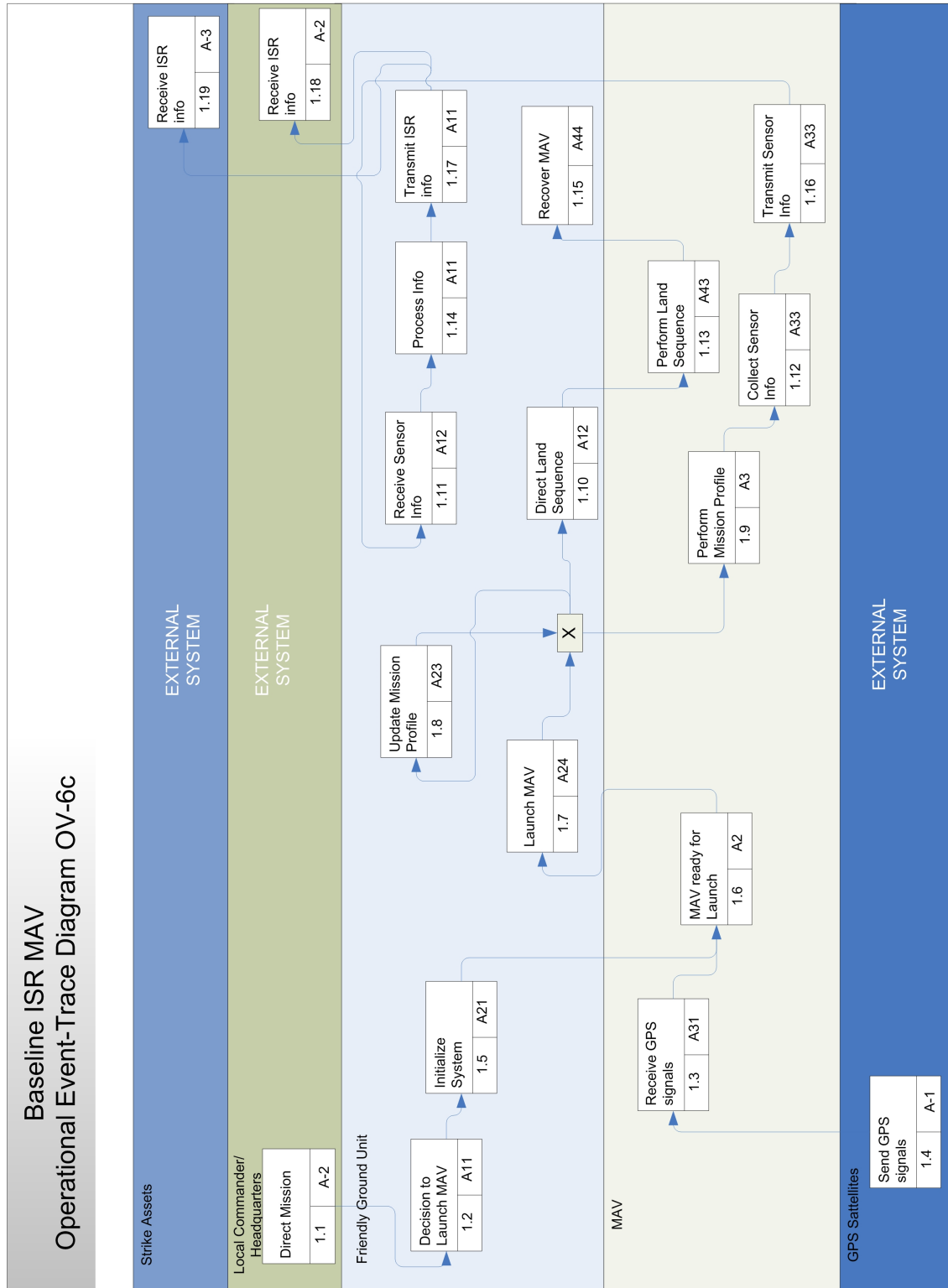

Figure I.1 OV-6c Operational Event-Trace Description

Appendix J. MAV OV-7

Table J.1 – AV-2 Integrated Dictionary

Entities, Attributes, and Relationships	Description
Graphical Box Types: Entities	
Navigation Data	Description: Entity that represents positional data provided by the GPS constellation for use by the MAV. Type: Independent Entity Keys: SatPRN (PK) Dependent Entities: Raw Data Attributes: Ephemeris
Tasking	Description: Entity containing information required to uniquely identify each tasking. Type: Independent Entity Keys: TaskID (PK) Dependent Entities: User Commands Attributes: Requester, Priority, Instructions
System Status	Description: Entity containing MAV ISR system fault information. Type: Dependent Keys: Status (PK), VehicleID (FK), SensorID (FK), SatPRN (FK) Dependent Entities: User Commands Attributes: MAVLaunch Fault, Airframe Fault, Ground Station Fault, Navigation Fault
User Commands	Description: Entity containing the information relevant for the initialization and use of the MAV ISR collection system. Type: Dependent Keys: TaskID (PFK), Status (PFK) Attributes: Flight Plan
Raw Flight Telemetry Data	Description: Entity containing unprocessed vehicle telemetry information. Type: Category Keys: VehicleID (PK), SatPRN (FK) Attributes: Vehicle Parameters
Raw Sensor Package Data	Description: Entity containing unprocessed information gathered by the sensor package.
Continued on next page	

Table J.1 – continued from previous page

Entities, Attributes, and Relationships	Description
	Type: Category Keys: SensorID (PK) Attributes: Sensor Data
Raw Data	Description: Entity containing unprocessed MAV ISR platform and sensor information. Type: Generic Dependent Keys: VehicleID (PK), SensorID (PK), TaskID (PFK), Status (PFK), SatPRN(PFK) Attributes: Decoded Sensor Package Data, FaultCodes
Fused Target Information	Description: Entity containing the processed MAV ISR information. Type: Dependent Keys: TaskID (PFK), VehicleID (FK), SensorID (FK), SatPRN(FK) Attributes: ISR Information
Graphical Arrow Types:	Relationships
Tasking to User Commands	Relationship: Required for Multiplicity: 1-* to 1
System Status to Navigation Data	Relationship: Requires Multiplicity: 1 to 0..*
User Commands to System Status	Relationship: Requires Multiplicity: 1 to 1
Raw Data to Navigation Data	Relationship: Uses Multiplicity: 1 to 1..*
System Status to Raw Data	Relationship: interprets Multiplicity: 1 to 1
Raw Data to User Commands	Relationship: Requires Multiplicity: 1..* to 1
Fused Target Information to Raw Data	Relationship: Requires Multiplicity: 1 to 1..*

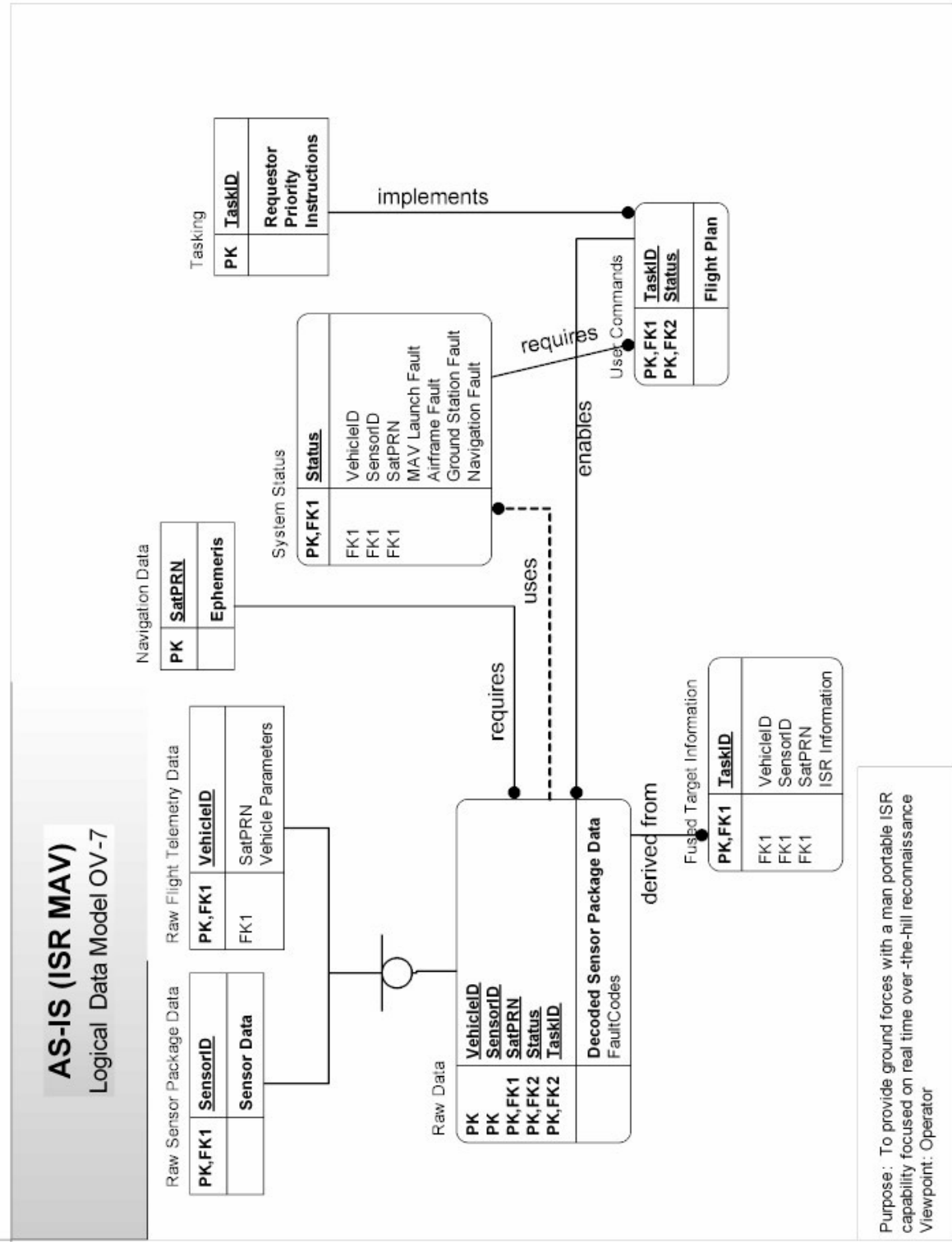

Figure J.1 Logical Data Model (OV-7)

Appendix K. MAV SV-1

Table K.1 – AV-2 Integrated Dictionary

Entities, Attributes, and Relationships	Description
Graphical Box Types:	System Nodes
Friendly Ground Unit	Synonymous with the Friendly Ground Unit operational node (reference the OV-2 definition table)
MAV	Synonymous with the MAV operational node (reference the OV-2 definition table)
Graphical Box Types:	Systems
Air Vehicle	<p>Description: The Air Vehicle system allows other systems within the MAV system node to operate as airborne systems. Functions performed by this system include: Take Flight, Flight Control, Power Source, and Flight Data Protocol. Examples of hardware systems that could perform these functions are an aircraft fuselage with wings, autopilot, and/or a battery. Synonymous to Perform Air Vehicle Functions.</p> <p>Type: System</p> <p>Views: SV-1b, SV-1c, SV-4, SV-5, SV-6</p>
Field Communication System	<p>Description: The Field Communication System allows the Human Operator to communicate gathered ISR information and mission directives with higher Headquarters and/or Strike Assets. Such a system can include items such as SATCOM or a hand held radio. This system performs the following functions: Transmit ISR Info, Receive Directives, Modulate ISR Info, and De-Modulate Directives. Synonymous to Provide Field Communication.</p> <p>Type: System</p> <p>Views: SV-1b, SV-1c, SV-4, SV-5, SV-6</p>
GPS Satellites	<p>Description: The Global Positioning System consists of a constellation of satellites providing pseudorange numbers and ephemeris data. Ground based receivers use this information to calculate their location.</p>

Continued on next page

Table K.1 – continued from previous page

Entities, Attributes, and Relationships	Description
	<p>Type: External System Views: OV-1, OV-2, OV-3, OV-6c, SV-1b, SV-1c, SV-4, SV-6</p>
Headquarters	<p>Description: Headquarters encompasses any unit or group that the operator is required to report to, or is considered at a higher level in the operators chain of command. This unit can be stationed locally in respect to the operator (in the field) or remote (far away from the operator). Headquarters can do any number of tasks, including making decisions based on gathered intelligence, assigning missions or directives to field units, or providing intelligence information. Synonymous to AOC or Local Commanders. Type: External System Views: OV-1, OV-2, OV-3, OV-6c, SV-1b, SV-1c, SV-4, SV-6</p>
Human Computer Interface (HCI)	<p>Description: The HCI system includes those items that give feedback (display, speakers) to users, or Human Operator, as well as those that allow users to supply input to the system (keyboard, mouse, touch screen, microphone). Its system functions include Give Feedback and Accept Input. Synonymous to Provide Human Computer Interface. Type: System Views: SV-1b, SV-1c, SV-4, SV-5, SV-6</p>
Human Operator	<p>Description: The Human Operator system is a model of the operators role in the system. The operator either affects the system through direct contact (Platform Interface and Field Comm Interface), through the HCI system (User Feedback and Inputs interface), or through the request of outside maintenance to the Maintenance Depot system. Functions performed by the Human Operator are Process Info, Influence System, Route Info, and Maintain System. Synonymous to Perform Human Operator Functions. Type: System</p>
Continued on next page	

Table K.1 – continued from previous page

Entities, Attributes, and Relationships	Description
	Views: SV-1b, SV-1c, SV-4, SV-5, SV-6
Maintenance Depot	<p>Description: The Maintenance Depot includes any unit or outside system that performs maintenance or support on all internal systems. Although the diagram only shows an interface with the Human Operator system, the Maintenance Depot actually interfaces with all systems in both system nodes. Since this maintenance function is viewed external its interfaces are not shown. To better define, the main purpose of this system is to perform maintenance that cannot be performed in the field by the Human Operator.</p> <p>Type: External System</p> <p>Views: OV-2, OV-3, OV-6c, SV-1b, SV-1c, SV-6</p>
MAV Airborne Communication System	<p>Description: The MAV Airborne Communication System allows airborne systems (MAV) to communicate gathered data, directives, and status information with ground systems (Friendly Ground Unit). This system accomplishes this by ensuring that data can be sent to and received from the MAV Ground Communication System. System functions include: Transmit Data, Receive MAV Directives, Modulate Data, De-Modulate MAV Directives, and Accept Supplied Power. Examples of such hardware equipment include transmitters, receivers and antennas. Synonymous to Provide MAV Airborne Communication System.</p> <p>Type: System</p> <p>Views: SV-1b, SV-1c, SV-4, SV-5, SV-6</p>
Continued on next page	

Table K.1 – continued from previous page

Entities, Attributes, and Relationships	Description
MAV Ground Communication System	<p>Description: The MAV Ground Communication System allows ground systems (Friendly Ground Unit) to communicate directives with the airborne systems (MAV). This system accomplishes this by ensuring that data can be sent to and received from the MAV Airborne Communication System.</p> <p>System functions include: Transmit MAV Directives, Receive Data, Modulate MAV Directives, and De-Modulate Data. Examples of such hardware equipment include transmitters, receivers and antennas. Synonymous to Provide MAV Ground Communication System.</p> <p>Type: System</p> <p>Views: SV-1b, SV-1c, SV-4, SV-5, SV-6</p>
Payload or Sensor Package	<p>Description: The Payload or Sensor Package systems purpose is to collect and provide the needed ISR information. It accomplishes this by performing the following functions: Enable ISR Capability, Convert Data, and Payload Data Protocol. This system utilizes the power source supplied by the Air Vehicle system to obtain ISR information and send it to the MAV Airborne Communication System. Synonymous to Perform Payload or Sensor Package Functions.</p> <p>Type: System</p> <p>Views: SV-1b, SV-1c, SV-4, SV-5, SV-6</p>
Signal/Data Processor	<p>Description: The Signal/Data Processor system Processes, Converts, and Manipulates data (those are the system functions) such that the proper data packets can be delivered to the HCI and the MAV Ground Communication System.</p> <p>Type: System</p> <p>Views: SV-1b, SV-1c, SV-4, SV-5, SV-6</p>
Strike Assets	<p>Description: Strike assets are any operational unit that has the capability to inflict damage on the enemy. Examples include aircraft (A-10), ground units (artillery), or sea based units (cruiser).</p> <p>Type: External System</p>
Continued on next page	

Table K.1 – continued from previous page

Entities, Attributes, and Relationships	Description
	Views: OV-1, OV-2, OV-3, OV-6c, SV-1b, SV-1c, SV-4, SV-6
Graphical Arrow Types:	Interfaces
BDI Request and Feedback	<p>Description: Included in this interface are BDI request and feedback sent from and to the Strike Assets through the Field Communication System. BDI request include the type of strike, last known enemy positions (or location of strike) using a standardized coordinate system, and when the strike is scheduled (if not already occurred). BDI feedback includes general information sent back to the strike asset concerning BDI mission results. Synonymous with Communicate with Local Strike Assets.</p> <p>Endpoint 1: Strike Assets Endpoint 2: Field Communication System Type: External Interface Views: OV-2, OV-3, SV-1b, SV-1c, SV-6</p>
Feedback and Input Data	<p>Description: The Feedback and Input Data interface includes any information sent to or from the operator through the HCI. Feedback is sent from the Signal/Data Processor system to the HCI while Input Data is sent from the HCI to the Signal/Data Processor.</p> <p>Endpoint 1: Human Computer Interface Endpoint 2: Signal/Data Processor Type: System Interface Views: SV-1c (Friendly Ground Unit) , SV-6</p>
Field Comm Interface	<p>Description: The Field Comm Interface includes all information sent to the Human Operator from external systems or vice versa using the Field Communication System. This interface can include audible or visual data.</p> <p>Endpoint 1: Human Operator Endpoint 2: Field Communication System Type: System Interface Views: SV-1c (Friendly Ground Unit) , SV-4, SV-6</p>
Continued on next page	

Table K.1 – continued from previous page

Entities, Attributes, and Relationships	Description
Information Gathered, Mission Tasks, Intelligence Info	<p>Description: As the name implies this link includes sending ISR information gathered to Headquarters, and receiving both mission tasks and intelligence information from Headquarters. Synonymous with Communicate with Headquarters.</p> <p>Endpoint 1: Headquarters</p> <p>Endpoint 2: Field Communication Interface</p> <p>Type: External Interface</p> <p>Views: OV-2, OV-3, SV-1b, SV-1c, SV-6</p>
Maintenance Required	<p>Description: This interface depicts interaction between the Human Operator and the Maintenance Depot. Included here is the Human Operators request for maintenance to be performed on any system within the system nodes and the Maintenance Depots acknowledgement of completed maintenance. Such maintenance requests occur whenever the Human Operator is not capable or it is out of the scope of the Maintain System function (implying field level maintenance).</p> <p>Endpoint 1: Maintenance Depot</p> <p>Endpoint 2: Human Operator</p> <p>Type: External Interface</p> <p>Views: SV-1b, SV-1c (Friendly Ground Unit), SV-6</p>
MAV Directives and Payload Data	<p>Description: The MAV Directives and Payload Data interface encompasses directives to be sent to the Air Vehicle system and payload data to be sent to the Signal/Data Processor. Directives primarily include flight control data and are first sent to the MAV Ground Communications System. Payload Data includes any ISR data gathered and sent by the Payload or Sensor Package system.</p> <p>Endpoint 1: Signal/Data Processor</p> <p>Endpoint 2: MAV Ground Communications System</p> <p>Type: System Interface</p> <p>Views: SV-1c (Friendly Ground Unit) , SV-6</p>
Continued on next page	

Table K.1 – continued from previous page

Entities, Attributes, and Relationships	Description
Navigation Data	<p>Description: Depending on the view, navigation data can either be an operational needline (OVs) or an external interface (SVs). This link includes the pseudorange numbers and ephemeris data transmitted by the GPS satellites.</p> <p>Endpoint 1: GPS Satellites Endpoint 2: Air Vehicle Type: External Interface Views: OV-1, OV-2, OV-3, OV-5, OV-7, SV-1b, SV-1c, SV-4, SV-6</p>
Payload Data	<p>Description: The Payload Data interface represents ISR data collected by the Payload or Sensor Package system sent to the MAV Airborne Communication System. This interface includes data that has been converted and is ready to be accepted by the MAV Airborne Communication System.</p> <p>Endpoint 1: Payload or Sensor Package Endpoint 2: MAV Airborne Communication System Type: System Interface Views: SV-1c (MAV) , SV-4, SV-6</p>
Platform Interface	<p>Description: The Platform Interface involves any direct contact between the Human Operator and Air Vehicle systems. This can include actions to perform maintenance, set-up, or tear-down functions.</p> <p>Endpoint 1: Human Operator Endpoint 2: Air Vehicle Type: System Interface Views: SV-1b, SV-1c, SV-4, SV-6</p>
Power Interface	<p>Description: The Power Interface represents the link between a power source within the Air Vehicle system and the Payload or Sensor Package system. If no power is required by the Payload or Sensor Package system then this interface does not exist. Synonymous to Power.</p> <p>Endpoint 1: Air Vehicle</p>
Continued on next page	

Table K.1 – continued from previous page

Entities, Attributes, and Relationships	Description
	Endpoint 2: Payload or Sensor Package Type: System Interface Views: SV-1c (MAV) , SV-4, SV-6
Power, MAV Directives, and Status Interface	Description: The Power, MAV Directives, and Status Interface represents three links. The first is a link between a power source within the Air Vehicle and the MAV Airborne Communication System. If no power is required by the Airborne Communication System then the power interface piece does not exist. The second link is MAV Directives sent from the Airborne Communication System to the Air Vehicle. These directives include mainly flight control data. And the third link contains flight status information sent from the Air Vehicle to the MAV Airborne Communication System; such information includes present location of the MAV. Endpoint 1: Air Vehicle Endpoint 2: MAV Airborne Communication System Type: System Interface Views: SV-1c (MAV) , SV-6
Request / Commands, ISR Data	Description: The Request/Commands, ISR Data Interface includes all airborne communications between the Friendly Ground Unit and MAV system nodes. This system communication interface includes request or commands (Raw Flight Telemetry Data) sent from the MAV Ground Communication System to the MAV Airborne Communications System and then gathered ISR data (Raw Sensor Package Data) sent from the Airborne to the Ground Communications System. Primarily this interface represents wireless communication that has been modulated using a pre-determined technique (spread spectrum). Endpoint 1: MAV Ground Communication System Endpoint 2: MAV Airborne Communication System

Continued on next page

Table K.1 – continued from previous page

Entities, Attributes, and Relationships	Description
	Type: System Interface Views: SV-1b, SV-1c, SV-6
User Feedback and Inputs	Description: This interface includes any feedback for the operator or user as well as inputs generated by the operators actions. User feedback is sent from the HCI to the Human Operator and can include any means for a computer to communicate to the operator (ex: visual, audible signals). User inputs are generated by the Human Operator and are gathered by the HCI. Endpoint 1: Human Operator Endpoint 2: Human Computer Interface (HCI) Type: System Interface Views: SV-1c (Friendly Ground Unit) , SV-6
Non-Graphical Types:	System Functions
Accept Input	Description: This system function is apart of the HCI system. Its purpose is to allow the user to supply input to the system in an easy and swift manner. The input supplied should integrate itself with the Give Feedback system function such that the user can see what the system has accepted before the execution. Type: System Function Views: SV-1b, SV-1c, SV-4, SV-5, SV-6
Accept Supplied Power	Description: This system function is apart of the MAV Airborne Communication System. Its purpose is to consume and utilize the power supplied by another system within the MAV system node; in this case it is from the Air Vehicle system. Note that if no power is needed by the MAV Airborne Communication System then this function does not apply. Type: System Function Views: SV-1b, SV-1c, SV-4, SV-5, SV-6
Continued on next page	

Table K.1 – continued from previous page

Entities, Attributes, and Relationships	Description
Convert/Route Data	<p>Description: This system function is performed by the Signal/Data Processor; its purpose is to convert then route data going to other systems as well as to route then convert data coming from other systems. Converting implies performing operations on received data such that it can be processed as well as on outgoing data such that the gaining system can read it. Routing, as the name implies, includes sending the data to the intended gaining unit as well as moving data internal to the Signal/Data Processor system.</p> <p>Type: System Function Views: SV-1b, SV-1c, SV-4, SV-5, SV-6</p>
Convert ISR Data	<p>Description: This system function is performed by the Payload or Sensor Package system; its purpose is to covert raw data such that the gaining system can read it. Examples include a digital to analog converter.</p> <p>Type: System Function Views: SV-1b, SV-1c, SV-4, SV-5, SV-6</p>
De-Modulate Data	<p>Description: This function is apart of the MAV Ground Communication System; its purpose is to de-modulate and/or decrypt the Payload Data being sent from the MAV Airborne Communication System. There are many de-modulation techniques and the one that is used is based on the modulation technique used by the transmitting system. If the signal is not modulated then this function is void.</p> <p>Type: System Function Views: SV-1b, SV-1c, SV-4, SV-5, SV-6</p>
De-Modulate Directives	<p>Description: This function is apart of the Field Communication System, its purpose is to de-modulate and/or decrypt the mission directives being sent from Headquarters or Strike Assets. There are many de-modulation techniques and the one that is used is based on the modulation technique used by the transmitting system. If the signal is not modulated then this function is void.</p>
Continued on next page	

Table K.1 – continued from previous page

Entities, Attributes, and Relationships	Description
	Type: System Function Views: SV-1b, SV-1c, SV-4, SV-5, SV-6
De-Modulate MAV Directives	Description: This function is apart of the MAV Airborne Communication System; its purpose is to de-modulate and/or decrypt the MAV Directives (see MAV Directives and Payload Data) being sent from the MAV Ground Communication System. There are many de-modulation techniques and the one that is used is based on the modulation technique used by the transmitting system. If the signal is not modulated then this function is void. Type: System Function Views: SV-1b, SV-1c, SV-4, SV-5, SV-6
Enable ISR Capability	Description: This system function is performed by the Payload or Sensor Package system; its purpose is to gather the needed ISR information. Sensors are the main items intended to perform this function, however the kind and type of sensor should be determined based on the particular ISR mission. Implied within this function is the ability to accept supplied power, in this case the power being supplied is from the Air Vehicle system. Type: System Function Views: SV-1b, SV-1c, SV-4, SV-5, SV-6
Flight Control	Description: This system function is performed by the Air Vehicle system; its purpose is to provide the needed hardware and software to follow the MAV Directives (flight control data). Such directives can include left/right turns, altitude level, and flight patterns. System examples include autopilot, flaps, ailerons, servo motors, etc. Type: System Function Views: SV-1b, SV-1c, SV-4, SV-5, SV-6
Continued on next page	

Table K.1 – continued from previous page

Entities, Attributes, and Relationships	Description
Flight Data Protocol	<p>Description: This system function is performed by the Air Vehicle system; its purpose is to send/receive data to/from the MAV Airborne Communication System based on a set of protocol rules. One example of a protocol rule is to send a data type stamp on each set of data such that the gaining system knows what type of data it is. Depending on the data bus structure and how the Power, MAV Directives, and Status Interface is implemented this function may be very complex, simple, or not exists.</p> <p>Type: System Function Views: SV-1b, SV-1c, SV-4, SV-5</p>
Give Feedback	<p>Description: This system function is apart of the HCI system. Its purpose is to supply feedback to the user in an easy and quick to understand method. The feedback given should use the same terms as well as integrate itself with the Accept Input system function such that the user can react quickly and accurately.</p> <p>Type: System Function Views: SV-1b, SV-1c, SV-4, SV-5, SV-6</p>
Influence System	<p>Description: The Influence System function is performed by the Human Operator; its purpose is to affect other systems through direct operator contact. This function could contain switching a switch, performing set-up/tear-down, pressing buttons resulting in system input, etc.</p> <p>Type: System Function Views: SV-1b, SV-1c, SV-4, SV-5, SV-6</p>
Continued on next page	

Table K.1 – continued from previous page

Entities, Attributes, and Relationships	Description
Maintain System	<p>Description: This function is performed by the Human Operator; its purpose is similar to Influence System however the Maintain System function focuses only on field level maintenance actions. Examples include changing batteries, repairing a wing, or installing a new item. If the level of maintenance is outside that of what can be done in the field then this function acts as a maintenance request function to notify the Maintenance Depot of a problem.</p> <p>Type: System Function Views: SV-1b, SV-1c, SV-4, SV-5, SV-6</p>
Manipulate Data	<p>Description: This system function is performed by the Signal/Data Processor; its purpose is similar to the Process Data function however data manipulation focuses on reprocessing already processed data. For example, once data is processed it can be dumped into local memory and then reprocessed or manipulated to better suit the operators or systems needs (image zooming).</p> <p>Type: System Function Views: SV-1b, SV-1c, SV-4, SV-5</p>
Modulate Data	<p>Description: This function is apart of the MAV Airborne Communication System; its purpose is to modulate and/or encrypt the Payload Data and status information being sent to the MAV Ground Communication System. There are many modulation techniques and the one that is used is based on the hardware system available or the system to receive the data (i.e. MAV Ground Communication System). If the system receiving the Payload Data is not capable of de-modulating the modulated signal then this function is void.</p> <p>Type: System Function Views: SV-1b, SV-1c, SV-4, SV-5, SV-6</p>
Continued on next page	

Table K.1 – continued from previous page

Entities, Attributes, and Relationships	Description
Modulate ISR Info	<p>Description: This function is apart of the Field Communication System, its purpose is to modulate and/or encrypt the ISR information being sent to Headquarters or Strike Assets. There are many modulation techniques and the one that is used is based on the hardware system available, Human Operator, or the system to receive the ISR information. If the system receiving the ISR information is not capable of de-modulating the modulated signal then this function is void.</p> <p>Type: System Function Views: SV-1b, SV-1c, SV-4, SV-5, SV-6</p>
Modulate MAV Directives	<p>Description: This function is apart of the MAV Ground Communication System; its purpose is to modulate and/or encrypt the MAV Directives being sent to the MAV Airborne Communication System. There are many modulation techniques and the one that is used is based on the hardware system available or the system receiving the data (i.e. MAV Airborne Communication System). If the system receiving the MAV Directives is not capable of de-modulating the modulated signal then this function is void.</p> <p>Type: System Function Views: SV-1b, SV-1c, SV-4, SV-5, SV-6</p>
Payload Data Protocol	<p>Description: This system function is performed by the Payload or Sensor Package system; its purpose is to send data to the MAV Airborne Communication System based on a set of protocol rules. One example of a protocol rule is to send a data type stamp on each set of data such that the gaining system knows what type of data it is. Depending on the data bus structure and how the Payload Data Interface is implemented this function may be very complex, simple, or not exists.</p> <p>Type: System Function Views: SV-1b, SV-1c, SV-4, SV-5</p>
Continued on next page	

Table K.1 – continued from previous page

Entities, Attributes, and Relationships	Description
Power Source	<p>Description: The Power Source system function is performed by the Air Vehicle; its purpose is to provide all airborne systems (MAV) a power supply. Every airborne system has been architected to need a power supply, the amount or type of power needed will be determined by these systems. Examples of power sources are a battery, liquid fuel, gas, or fuel cell.</p> <p>Type: System Function</p> <p>Views: SV-1b, SV-1c, SV-4, SV-5, SV-6</p>
Process Data	<p>Description: This system function is performed by the Signal/Data Processor; its purpose is to perform simple or complex operations based on the data brought into the system. For example after receiving input data from the HCI system the Signal/Data Processor outputs a set of MAV Directives.</p> <p>Type: System Function</p> <p>Views: SV-1b, SV-1c, SV-4, SV-5, SV-6</p>
Process Info	<p>Description: This function is performed by the Human Operator; its purpose is to process the gathered ISR information and mission directives. Based on this processing, the Human Operator decides the next state of the system. For example, if the processing of the gathered ISR information resulted in an enemy tank location then the operator could make the decision to forward (or route) the information to Strike Assets.</p> <p>Type: System Function</p> <p>Views: SV-1b, SV-1c, SV-4, SV-5, SV-6</p>
Receive Data	<p>Description: This function is performed by the MAV Ground Communication System; its purpose is to receive Payload Data and status information from the MAV Airborne Communication System for the Signal/Data Processor system.</p> <p>Type: System Function</p> <p>Views: SV-1b, SV-1c, SV-4, SV-5, SV-6</p>
Continued on next page	

Table K.1 – continued from previous page

Entities, Attributes, and Relationships	Description
Receive Directives	<p>Description: This function is apart of the Field Communication System, its purpose is to provide the Human Operator with mission directives derived from Headquarters or Strike Assets. The hardware and software involved in receiving the directives should be based on the operators common scenario and mission.</p> <p>Type: System Function</p> <p>Views: SV-1b, SV-1c, SV-4, SV-5, SV-6</p>
Receive MAV Directives	<p>Description: This function is performed by the MAV Airborne Communication System; its purpose is to receive directives from the MAV Ground Communication System for the Air Vehicle system.</p> <p>Type: System Function</p> <p>Views: SV-1b, SV-1c, SV-4, SV-5, SV-6</p>
Route Info	<p>Description: This function is performed by the Human Operator; its purpose is to route the processed ISR information or mission directives to the appropriate system (Headquarters, Strike Assets, or the HCI). Only the processed data needed by the gaining system will be routed.</p> <p>Type: System Function</p> <p>Views: SV-1b, SV-1c, SV-4, SV-5, SV-6</p>
Take Flight	<p>Description: This function is performed by the Air Vehicle system; its purpose is to utilize the laws of aerodynamics to ensure that systems with in the MAV node can become airborne. Take-off, landing, and flight sustainment are implied within this system function.</p> <p>Type: System Function</p> <p>Views: SV-1b, SV-1c, SV-4, SV-5</p>
Continued on next page	

Table K.1 – continued from previous page

Entities, Attributes, and Relationships	Description
Transmit Data	<p>Description: The Transmit Data system function is performed by the MAV Airborne Communication System; its purpose is to transmit data generated by the payload (Payload Data interface) as well as status information generated by the Air Vehicle system (Power, MAV Directives, and Status Interface) to the MAV Ground Communication System.</p> <p>Type: System Function</p> <p>Views: SV-1b, SV-1c, SV-4, SV-5, SV-6</p>
Transmit ISR Info	<p>Description: This function is apart of the Field Communication System, its purpose is to provide Headquarters or Strike Assets ISR information. The hardware and software involved in transmitting the information should be based on the operators common scenario and mission.</p> <p>Type: System Function</p> <p>Views: SV-1b, SV-1c, SV-4, SV-5, SV-6</p>
Transmit MAV Directives	<p>Description: The Transmit MAV Directives system function is performed by the MAV Ground Communication System; its purpose is to transmit directives for the Air Vehicle system generated by the Signal/Data Processor system to the MAV Airborne Communication System.</p> <p>Type: System Function</p> <p>Views: SV-1b, SV-1c, SV-4, SV-5, SV-6</p>
Referenced Types	
Needline	See OV-2 Definition Table
Operational Node	See OV-2 Definition Table
Relationships	
Systems Node	Systems
Friendly Ground Unit	Human Operator, Human Computer Interface (HCI), Signal/Data Processor, Field Communication System, MAV Ground Communication System
MAV	Air Vehicle, Payload or Sensor Package, MAV Airborne Communication System
System (within system nodes)	System Functions

Continued on next page

Table K.1 – continued from previous page

Entities, Attributes, and Relationships	Description
Air Vehicle	Take Flight, Flight Control, Power Source, Flight Data Protocol
Field Communication System	Transmit ISR Info, Receive Directives, Modulate ISR Info, De-Modulate Directives
Human Computer Interface (HCI)	Give Feedback, Accept Input
Human Operator	Process Info, Influence System, Route Info, Maintain System
MAV Airborne Communication System	Transmit Data, Receive MAV Directives, Modulate Data, De-Modulate MAV Directives, Accept Supplied Power
MAV Ground Communication System	Transmit MAV Directives, Receive Data, Modulate MAV Directives, De-Modulate Data
Payload or Sensor Package	Enable ISR Capability, Convert ISR Data, Payload Data Protocol
Signal/Data Processor	Convert/Route Data, Process Data, Manipulate Data
System Node	Operational Node
Friendly Ground Unit	Friendly Ground Unit
MAV	MAV
System Interface (SV-1b only)	Operational Needline
BDI Request and Feedback	Communicate with Local Strike Assets
Information Gathered, Mission Tasks, Intelligence Info	Communicate with Headquarters
Maintenance Required	System Maintenance Needed/Request
Navigation Data	Navigation Data
Platform Interface	Platform Communication
Request/Commands, ISR Data	Platform Communication

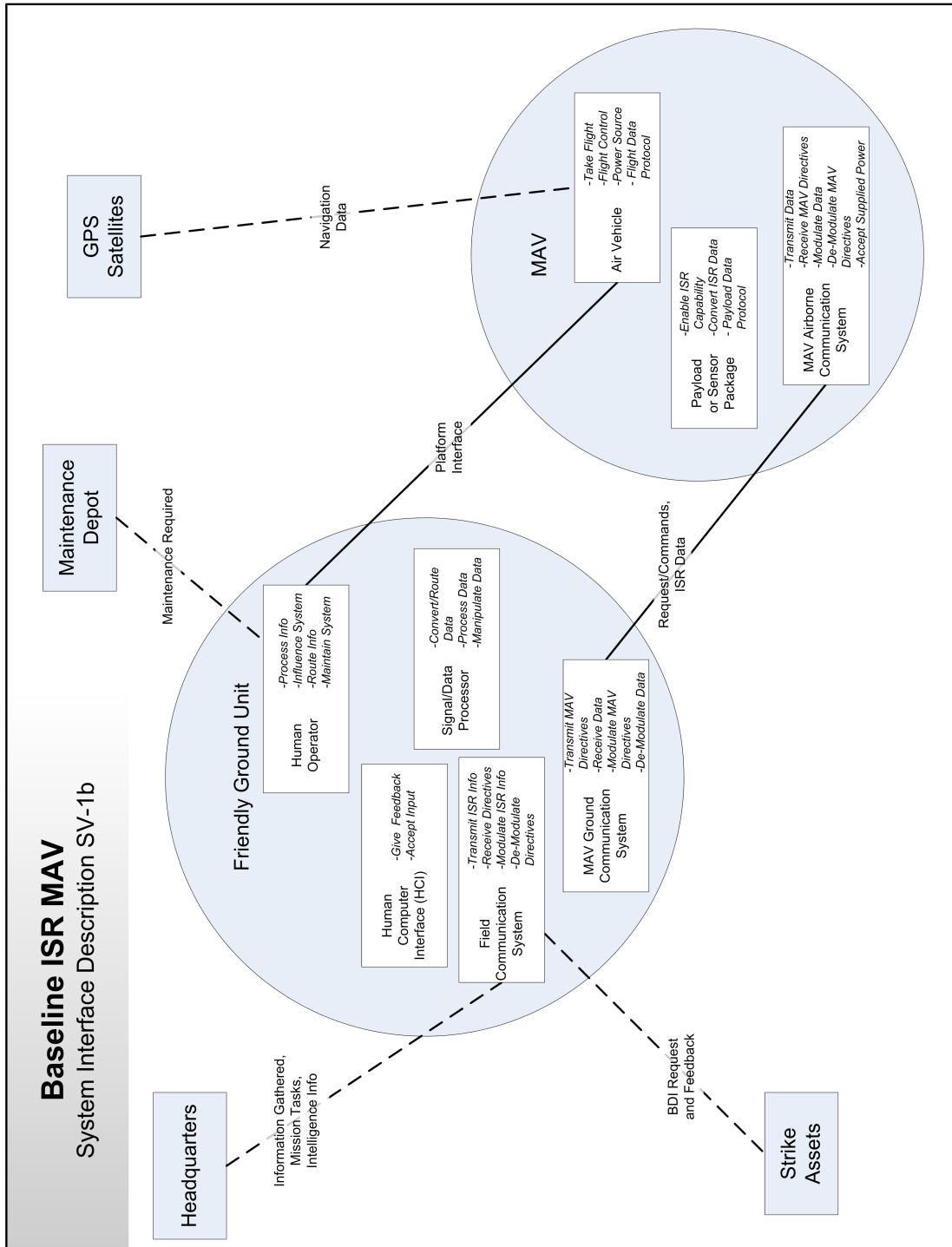

Figure K.1 SV-1b Systems Interface Description: Internodal Version showing System-System Interfaces

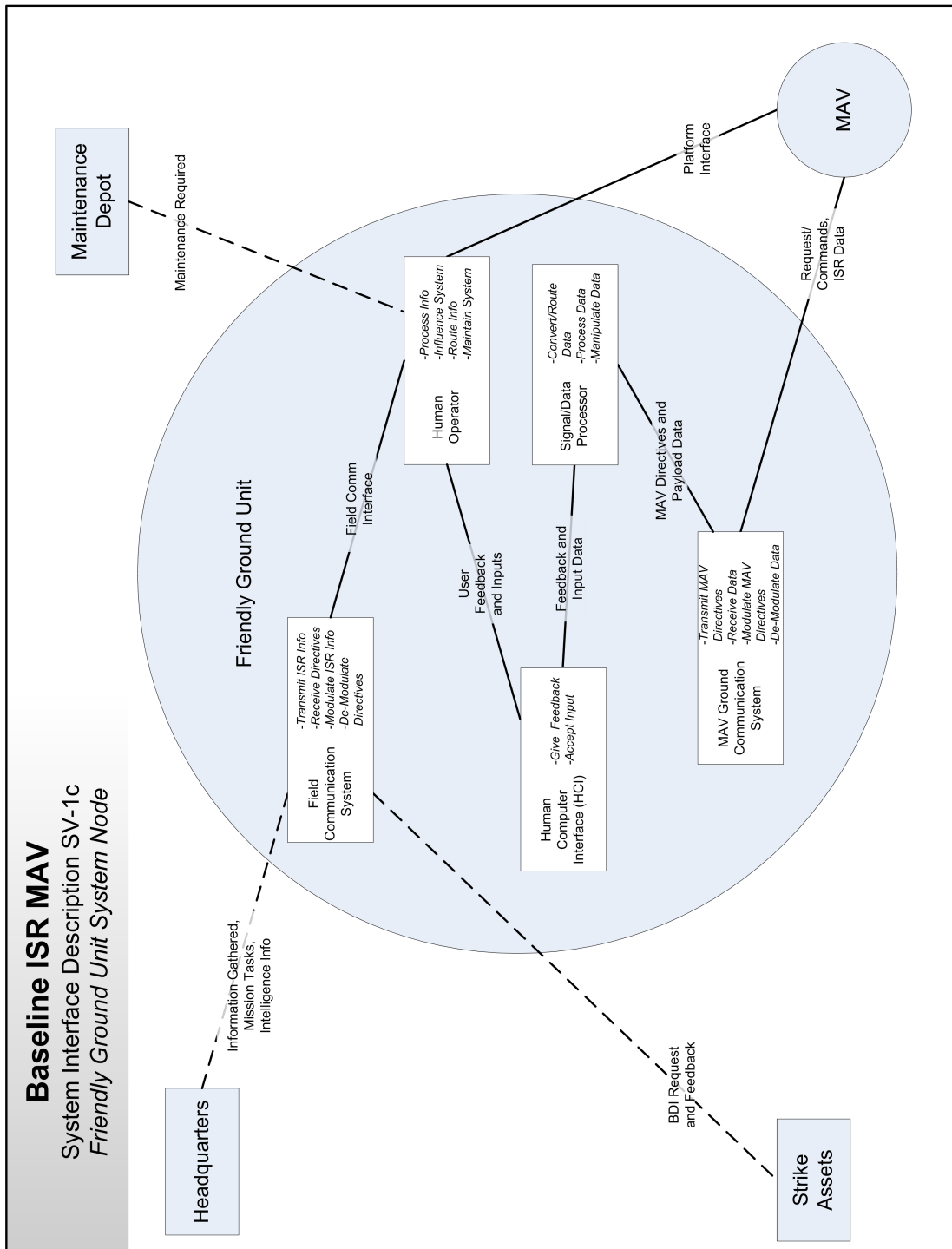

Figure K.2 SV-1c Systems Interface Description: Intranodal Version of the *Friendly Ground Unit* showing System-System Interfaces and System Functions

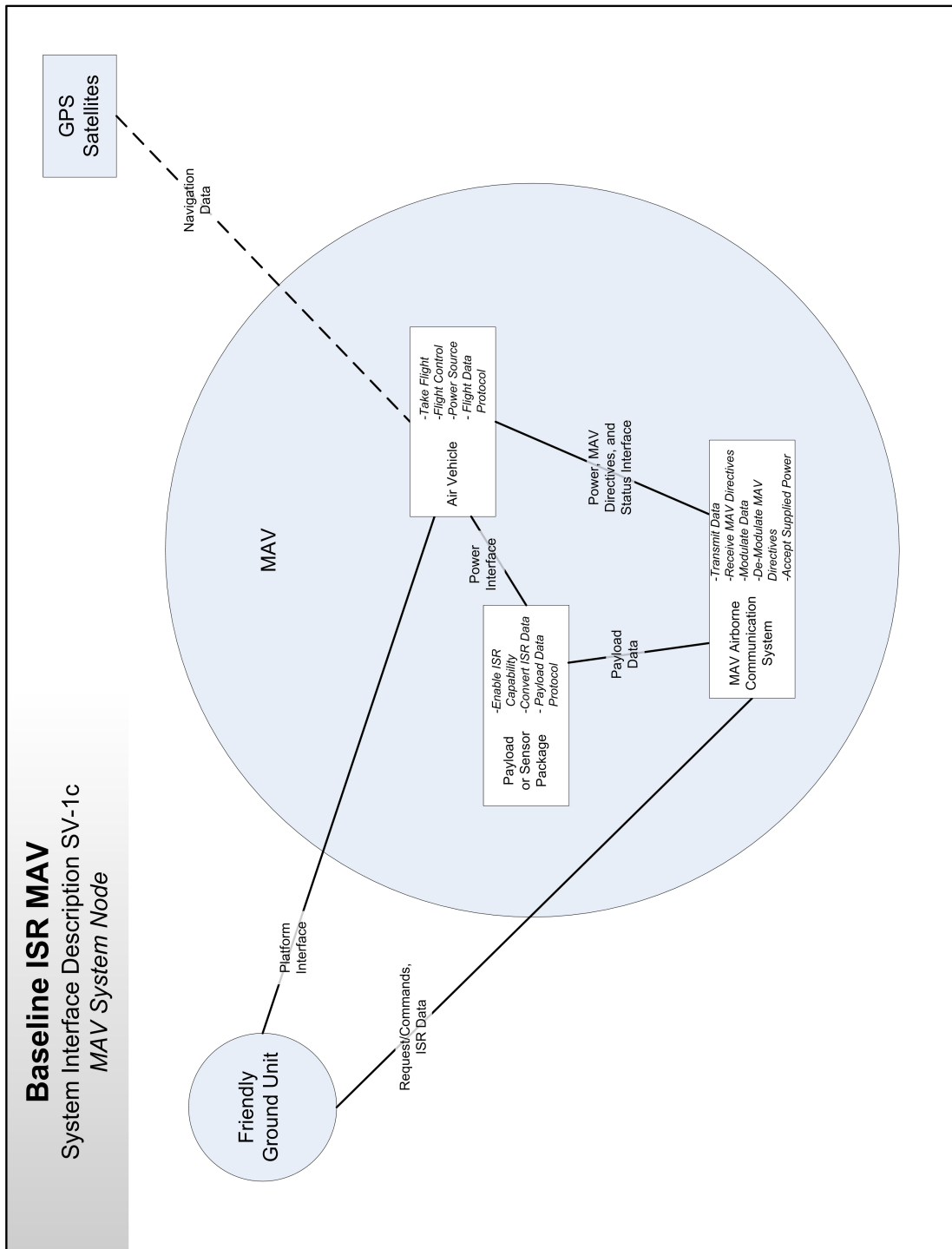

Figure K.3 SV-1c Systems Interface Description: Intranodal Version of the MAV showing System-System Interfaces and System Functions

Appendix L. MAV SV-4

Table L.1 – AV-2 Integrated Dictionary

Entities, Attributes, and Relationships	Description
Graphical Box Types:	External System Data Source/Sink
Strike Asset	Description: See OV-1 Definition Table Views: OV-1, OV-2, OV-3, OV-5, OV-6c, SV-1b, SV-1c, SV-4, SV-5, SV-6
Headquarters	Description: See OV-1 (AOC) and OV-2 Definition Tables Views: OV-1, OV-2, OV-3, OV-5, OV-6c, SV-1b, SV-1c, SV-4, SV-5, SV-6
GPS Satellites	Description: See OV-1 Definition Table Views: OV-1, OV-2, OV-3, OV-5, OV-6c, SV-1b, SV-1c, SV-4, SV-5, SV-6
Graphical Box Types:	System Function
Accept Input	Description: See SV-1 Definition Table Reference: 1.2.2 Views: SV-1b, SV-1c, SV-4, SV-5, SV-6
Accept Supplied Power	Description: See SV-1 Definition Table Reference: 2.1.4 Views: SV-1b, SV-1c, SV-4, SV-5, SV-6
Convert/Route Data	Description: See SV-1 Definition Table Reference: 1.1.2 Views: SV-1b, SV-1c, SV-4, SV-5, SV-6
Convert ISR Data	Description: See SV-1 Definition Table Reference: 2.3.3 Views: SV-1b, SV-1c, SV-4, SV-5, SV-6
De-Modulate Data	Description: See SV-1 Definition Table Reference: 1.5.3 Views: SV-1b, SV-1c, SV-4, SV-5, SV-6
De-Modulate Directives	Description: See SV-1 Definition Table Reference: 1.3.4 Views: SV-1b, SV-1c, SV-4, SV-5, SV-6
De-Modulate MAV Directives	Description: See SV-1 Definition Table Reference: 2.1.3 Views: SV-1b, SV-1c, SV-4, SV-5, SV-6
Enable ISR Capability	Description: See SV-1 Definition Table Reference: 2.3.2
Continued on next page	

Table L.1 – continued from previous page

Entities, Attributes, and Relationships	Description
	Views: SV-1b, SV-1c, SV-4, SV-5, SV-6
Flight Control	Description: See SV-1 Definition Table Reference: 2.2.1 Views: SV-1b, SV-1c, SV-4, SV-5, SV-6
Flight Data Protocol	Description: See SV-1 Definition Table Reference: 2.2.3 Views: SV-1b, SV-1c, SV-4, SV-5, SV-6
Give Feedback	Description: See SV-1 Definition Table Reference: 1.2.1 Views: SV-1b, SV-1c, SV-4, SV-5, SV-6
Influence System	Description: See SV-1 Definition Table Reference: 1.4.3 Views: SV-1b, SV-1c, SV-4, SV-5, SV-6
Maintain System	Description: See SV-1 Definition Table Reference: 1.4.4 Views: SV-1b, SV-1c, SV-4, SV-5, SV-6
Manipulate Data	Description: See SV-1 Definition Table Reference: 1.1.1 Views: SV-1b, SV-1c, SV-4, SV-5, SV-6
Modulate Data	Description: See SV-1 Definition Table Reference: 2.1.5 Views: SV-1b, SV-1c, SV-4, SV-5, SV-6
Modulate ISR Info	Description: See SV-1 Definition Table Reference: 1.3.3 Views: SV-1b, SV-1c, SV-4, SV-5, SV-6
Modulate MAV Directives	Description: See SV-1 Definition Table Reference: 1.5.1 Views: SV-1b, SV-1c, SV-4, SV-5, SV-6
Payload Data Protocol	Description: See SV-1 Definition Table Reference: 2.3.1 Views: SV-1b, SV-1c, SV-4, SV-5, SV-6
Perform Air Vehicle Functions	Description: This function represents the aggregate of all lower functions performed by the Air Vehicle part of the MAV system. It is the sum of the sub-functions Flight Control, Take Flight, Flight data Protocol, and Power Source. Reference: 2.2 Views: SV-1b, SV-1c, SV-4, SV-5, SV-6
Continued on next page	

Table L.1 – continued from previous page

Entities, Attributes, and Relationships	Description
Perform Ground Unit Functions	Description: This function represents the aggregate of all lower functions performed by the Ground Unit. It is the sum of the sub-functions Signal/ data Processing, Provide Human Computer Interface, Provide Field Communication, Perform Human Operator Functions, and Provide MAV Ground Communication. Reference: 1 Views: SV-1b, SV-1c, SV-4, SV-5, SV-6
Perform Human Operator Functions	Description: This function represents the aggregate of all lower sub-functions performed by the Human Operator. It is the sum of the sub-functions Route Info, Process Info, Influence system, and Maintain System. Reference: 1.4 Views: SV-1b, SV-1c, SV-4, SV-5, SV-6
Perform MAV Functions	Description: This function represents the aggregate of all lower functions performed by the MAV. It is the sum of the sub-functions Provide MAV Airborne Communication, Perform Air Vehicle Functions and Perform Payload/ Sensor Functions. Reference: 2 Views: SV-1b, SV-1c, SV-4, SV-5, SV-6
Perform Payload/ Sensor Functions	Description: This function represents the aggregate of all lower functions performed by the Payload/ Sensor. It is the sum of the sub-functions Payload Data Protocol, Enable ISR Capability, and Convert ISR Data. Reference: 2.3 Views: SV-1b, SV-1c, SV-4, SV-5, SV-6
Power Source	Description: See SV-1 Definition Table Reference: 2.2.4 Views: SV-1b, SV-1c, SV-4, SV-5, SV-6
Process Data	Description: See SV-1 Definition Table Reference: 1.1.3 Views: SV-1b, SV-1c, SV-4, SV-5, SV-6
Process Info	Description: See SV-1 Definition Table Reference: 1.4.2
Continued on next page	

Table L.1 – continued from previous page

Entities, Attributes, and Relationships	Description
	Views: SV-1b, SV-1c, SV-4, SV-5, SV-6
Provide Field Communication	<p>Description: This function represents the aggregate of all lower functions performed by the Field Communication sub-system. It is the sum of the sub-functions Transmit ISR Information, Receive Directives, Modulate ISR Information, and De-Modulate Directives.</p> <p>Reference: 1.3</p> <p>Views: SV-1b, SV-1c, SV-4, SV-5, SV-6</p>
Provide Human Computer Interface	<p>Description: This function represents the aggregate of all lower functions performed by the Human Computer Interface. It is the sum of the sub-functions Give Feedback and Accept Input.</p> <p>Reference: 1.2</p> <p>Views: SV-1b, SV-1c, SV-4, SV-5, SV-6</p>
Provide ISR Capabilities	<p>Description: This function represents the aggregate of all lower functions performed by the ISR MAV system. It is the sum of the sub-functions Perform Ground Unit Functions and Perform MAV Functions. It is the top-level function for the system.</p> <p>Reference: Top Level Function</p> <p>Views: SV-1b, SV-1c, SV-4, SV-5, SV-6</p>
Provide MAV Airborne Communication	<p>Description: This function represents the aggregate of all lower functions performed by the MAV Airborne Communication sub-system. It is the sum of the sub-functions Transmit Data, Receive MAV Directives, De-Modulate MAV Directives, Accept Supplied Power, and Modulate Data.</p> <p>Reference: 2.1</p> <p>Views: SV-1b, SV-1c, SV-4, SV-5, SV-6</p>
Provide MAV Ground Communication	<p>Description: This function represents the aggregate of all lower functions performed by the MAV Ground Communication sub-system. It is the sum of the sub-functions Modulate MAV Directives, Transmit MAV Directives, De-Modulate Data, and Receive Data.</p> <p>Reference: 1.5</p>
Continued on next page	

Table L.1 – continued from previous page

Entities, Attributes, and Relationships	Description
	Views: SV-1b, SV-1c, SV-4, SV-5, SV-6
Receive Data	Description: See SV-1 Definition Table Reference: 1.5.4 Views: SV-1b, SV-1c, SV-4, SV-5, SV-6
Receive Directives	Description: See SV-1 Definition Table Reference: 1.3.2 Views: SV-1b, SV-1c, SV-4, SV-5, SV-6
Receive MAV Directives	Description: See SV-1 Definition Table Reference: 2.1.2 Views: SV-1b, SV-1c, SV-4, SV-5, SV-6
Route Info	Description: See SV-1 Definition Table Reference: 1.4.1 Views: SV-1b, SV-1c, SV-4, SV-5, SV-6
Signal/ Data Processing	Description: This function represents the aggregate of all lower functions performed by the Signal/ Data Processor sub-system. It is the sum of the sub-functions Manipulate data, Convert/ Route Data, and Process Data. Reference: 1.1 Views: SV-1b, SV-1c, SV-4, SV-5, SV-6
Take Flight	Description: See SV-1 Definition Table Reference: 2.2.2 Views: SV-1b, SV-1c, SV-4, SV-5, SV-6
Transmit Data	Description: See SV-1 Definition Table Reference: 2.1.1 Views: SV-1b, SV-1c, SV-4, SV-5, SV-6
Transmit ISR Info	Description: See SV-1 Definition Table Reference: 1.3.1 Views: SV-1b, SV-1c, SV-4, SV-5, SV-6
Transmit MAV Directives	Description: See SV-1 Definition Table Reference: 1.5.2 Views: SV-1b, SV-1c, SV-4, SV-5, SV-6
Graphical Box Types:	System Data Repository/ Shared Database
Continued on next page	

Table L.1 – continued from previous page

Entities, Attributes, and Relationships	Description
Processed Data	<p>Description: Repository of gathered and processed data from the air vehicle’s payload sensor. Data from this repository may be called by the manipulate data function to be formatted into output data at the user’s request. The repository will contain the images, videos, etc. from the sensor in their storable format. Operations such as re-zooming, cropping, image color enhancing, etc. would be performed by the manipulate data function.</p> <p>Within Reference: Signal/ Data Processing, 1.1 Data Flow: Processed Data Function From: Process Data, 1.1.3 Function To: Manipulate Data, 1.1.1 Views: SV-4</p>
Graphical Arrow Types:	System Data Flow
Commands	<p>Description: See SV-1 Definition Table for <i>Request/ Commands, ISR Data</i></p> <p>Function From: Transmit MAV Directives (1.5.2) Function To: Receive MAV Directives (2.1.2) Views: SV-1c, SV-4, SV-6</p>
Data Request	<p>Description: This data flow is a call or request for data from the Processed Data repository. This request will normally be in response to an Output Data Request ultimately from the user. This data request is necessary to manipulate the stored data to meet the user’s needs.</p> <p>Function From: Manipulate Data (1.1.1) Function To: Processed Data (Data Repository) Views: SV-4</p>
Decision to Communicate	<p>Description: This data flow is active decision by the human operator (through the Process Info function) to relay information through the Field Communication system.</p> <p>Function From: Process Info (1.4.2) Function To: Route Info (1.4.1) Views: SV-4</p>
Continued on next page	

Table L.1 – continued from previous page

Entities, Attributes, and Relationships	Description
Decision to Influence System	<p>Description: This data flow is active decision by the human operator (through the Process Info function) to affect influence on the system (e.g. turn system on, launch, recover MAV, etc.).</p> <p>Function From: Process Info (1.4.2)</p> <p>Function To: Influence System (1.4.3)</p> <p>Views: SV-4</p>
Decision to Maintain System	<p>Description: This data flow is active decision by the human operator (through the Process Info function) to perform a maintenance action on the system.</p> <p>Function From: Process Info (1.4.2)</p> <p>Function To: Maintain System (1.4.4)</p> <p>Views: SV-4</p>
Field Comm Interface	<p>Description: See SV-1 Definition Table</p> <p>Function From: Route Info (1.4.1) and De-Modulate Directives (1.3.4)</p> <p>Function To: Modulate ISR Information (1.3.3) and Process Info (1.4.2)</p> <p>Views: SV-1c, SV-4, SV-6</p>
Flight Control Commands	<p>Description: This data flow includes the flight surfaces commands necessary to affect the flight of the MAV air vehicle. They will be generated by the autopilot processor in response to a commanded flight profile.</p> <p>Function From: Flight Control (2.2.1)</p> <p>Function To: Take Flight (2.2.2)</p> <p>Views: SV-4</p>
Flight Control/ Position Data	<p>Description: This data flow includes feedback of what the flight control function is performing and the position information of the air vehicle as a result of processing the GPS satellite navigation data.</p> <p>Function From: Flight Control (2.2.1)</p> <p>Function To: Flight Data Protocol (2.2.3)</p> <p>Views: SV-4</p>
Continued on next page	

Table L.1 – continued from previous page

Entities, Attributes, and Relationships	Description
Flight Profile	<p>Description: This data flow is the received and formatted MAV directives that include where and how the MAV should fly. It will contain desired position, speed, altitude, loiter and other information required by the flight controller function to determine commands to the flight control surfaces.</p> <p>Function From: Flight Data Protocol (2.2.3)</p> <p>Function To: Flight Control (2.2.1)</p> <p>Views: SV-4</p>
Flight Status Data	<p>Description: This data flow gives feedback and position data to the ground unit of the air vehicles location and condition.</p> <p>Function From: Flight Data Protocol (2.2.3)</p> <p>Function To: Modulate Data (2.1.5)</p> <p>Views: SV-4</p>
Formatted Payload Data	<p>Description: This data flow is the formatted and packaged payload sensor data that the sensor has gathered.</p> <p>Function From: Convert ISR Data (2.3.3)</p> <p>Function To: Payload Data Protocol (2.3.1)</p> <p>Views: SV-4</p>
Fused Target Information	<p>Description: See OV-5 Definition Table</p> <p>Function From: Transmit ISR Information (1.3.1)</p> <p>Function To: Headquarters and Strike Assets (External Systems)</p> <p>Views: OV-5, OV-7, SV-1c, SV-4, SV-6</p>
Human Inputs	<p>Description: See SV-1 Definition Table for Inputs</p> <p>Function From: Influence System (1.4.3)</p> <p>Function To: Accept Input (1.2.2)</p> <p>Views: SV-1c, SV-4, SV-6</p>
Input Data	<p>Description: See SV-1 Definition Table for Input Data</p> <p>Function From: Accept Input (1.2.2)</p> <p>Function To: Convert/ Route Data (1.1.2)</p> <p>Views: SV-1c, SV-4, SV-6</p>
Continued on next page	

Table L.1 – continued from previous page

Entities, Attributes, and Relationships	Description
ISR/ Flight Status Data	<p>Description: This data flow is the combination of both the gathered payload sensor data and the flight status of the air vehicle that is sent to the ground unit. It's level of formatting and packaging is only that which would be necessary for communication to the ground unit.</p> <p>Function From: Transmit Data (2.1.1) Function To: Receive Data (1.5.4) Views: SV-1c, SV-4, SV-6</p>
MAV Directives	<p>Description: See SV-1 Definition Table</p> <p>Function From: Convert/ Route Data (1.1.2) and De-Modulate MAV Directives (2.1.3) Function To: Modulate MAV Directives (1.5.1) and Flight Data Protocol (2.2.3) Views: SV-1c, SV-4, SV-6</p>
Modulated Directives	<p>Description: This data flow is simply the directives that are modulated for transmittal to the MAV from the ground unit.</p> <p>Function From: Modulate MAV Directives (1.5.1) Function To: Transmit MAV Directives (1.5.2) Views: SV-4</p>
Modulated ISR Data	<p>Description: This data flow is simply the ISR info that is modulated for transmittal to either headquarters or the strike assets from the ground unit.</p> <p>Function From: Modulate ISR Info (1.3.3) Function To: Transmit ISR Information (1.3.1) Views: SV-4</p>
Modulated ISR/ Flight Status Data	<p>Description: This data flow is simply the ISR/ Flight Status Data modulated for transmittal to the ground unit from the MAV.</p> <p>Function From: Modulate Data (2.1.5) Function To: Transmit Data (2.1.1) Views: SV-4</p>
Modulated MAV Directives	<p>Description: This data flow is simply the MAV directives modulated for transmittal from the MAV communications system to the air vehicle flight control.</p>
Continued on next page	

Table L.1 – continued from previous page

Entities, Attributes, and Relationships	Description
	Function From: Receive MAV Directives (2.1.2) Function To: De-Modulate MAV Directives (2.1.3) Views: SV-4
Modulated Payload Data	Description: Function From: Receive Data (1.5.4) Function To: De-Modulate Data (1.5.3) Views: SV-4
Modulated Taskings	Description: This data flow is the taskings modulated for transmittal from Headquarters or Strike Assets to the Human Operator. Function From: Receive Directives (1.3.2) Function To: De-Modulate Directives (1.3.4) Views: SV-4
Navigation Data	Description: See OV-1 Definition Table Function From: GPS Satellites (External System) Function To: Flight Control (2.2.1) Views: OV-1, OV-2, OV-3, OV-5, OV-7, SV-1c, SV-4, SV-6
Output Data	Description: See SV-1 Definition Table for Feedback Function From: Manipulate Data (1.1.1) and Convert/ Route Data (1.1.2) Function To: Convert/ Route Data (1.1.2) and Give Feedback (1.2.1) Views: SV-1c, SV-4, SV-6
Output Data Request	Description: This data flow is a call or request for data to be manipulated. It can also carry commands on how the data is to be manipulated (e.g. resize, zoom, etc.). Function From: Convert/ Route Data (1.1.2) Function To: Manipulate Data (1.1.1) Views: SV-4
Payload Data	Description: See SV-1 Definition Table Function From: Payload Data Protocol (2.3.1) Function To: Modulate Data (2.1.5) Views: OV-5, OV-7, SV-1c, SV-4, SV-6

Continued on next page

Table L.1 – continued from previous page

Entities, Attributes, and Relationships	Description
Payload/ Flight Status Data	<p>Description: This data flow includes all information transmitted from the MAV to the ground unit. It is unprocessed information to be transformed and used by the ground unit.</p> <p>Function From: De-Modulate Data (1.5.3)</p> <p>Function To: Convert/ Route Data (1.1.2)</p> <p>Views: OV-7, SV-1c, SV-4, SV-6</p>
Platform Interface	<p>Description: See SV-1 Definition Table</p> <p>Function From: Influence System (1.4.3) and Maintain System (1.4.4)</p> <p>Function To: Take Flight (2.2.2)</p> <p>Views: SV-1c, SV-4, SV-6</p>
Power	<p>Description: See SV-1 Definition Table</p> <p>Function From: Power Source (2.2.4)</p> <p>Function To: Enable ISR Capability (2.3.2) and Accept Supplied Power (2.1.4)</p> <p>Views: SV-1c, SV-4, SV-6</p>
Processed Data	<p>Description: This data flow is the processed, formatted, and packaged data from the MAV. Images and/or videos are saved in acceptable file formats.</p> <p>Function From: Process Data (1.1.3) and Processed Data (Data Repository)</p> <p>Function To: Processed Data (Data Repository) and Manipulate Data (1.1.1)</p> <p>Views: SV-4</p>
Raw Payload Data	<p>Description: This data flow is the basic electronic signals generated by the payload sensor in response to the target of its sensor gathering function.</p> <p>Function From: Enable ISR Capability (2.3.2)</p> <p>Function To: Convert ISR Data (2.3.3)</p> <p>Views: SV-4</p>
Repair/ Fault Status	<p>Description: See OV-5 Definition Table for System Repair Status</p> <p>Function From: Maintain System (1.4.4)</p> <p>Function To: Process Info (1.4.2)</p> <p>Views: OV-5, OV-7, SV-4</p>
System Status	<p>Description: See OV-7 Definition Table</p>
Continued on next page	

Table L.1 – continued from previous page

Entities, Attributes, and Relationships	Description
	Function From: Influence System (1.4.3) Function To: Process Info (1.4.2) Views: OV-7, SV-4
Taskings	Description: See OV-5 Definition Table Function From: Headquarters and Strike Assets (External Systems) Function To: Receive Directives (1.3.2) Views: OV-5, OV-7, SV-1c, SV-4, SV-6
Unprocessed Data	Description: This data flow is the data that has been received by the ground unit communications system from the MAV. Function From: Convert/ Route Data (1.1.2) Function To: Process Data (1.1.3) Views: SV-4
User Feedback	Description: See SV-1 Definition Table Function From: Give Feedback (1.2.1) Function To: Process Info (1.4.2) Views: SV-1c, SV-4, SV-6
Functional Decomposition	
Super Function	Sub-Functions
Provide ISR Capabilities	1. Perform Ground Unit Functions 2. Perform MAV Functions
1. Perform Ground Unit Functions	1.1 Signal/ Data Processing 1.2 Provide Human Computer Interface 1.3 Provide Field Communication 1.4 Perform Human Operator Functions 1.5 Provide MAV Ground Communication
2. Perform MAV Functions	2.1 Provide MAV Airborne Communication 2.2 Perform Air Vehicle Functions 2.3 Perform Payload/Sensor Functions
1.1 Signal/ Data Processing	1.1.1 Manipulate Data 1.1.2 Convert/ Route Data 1.1.3 Process Data
1.2 Provide Human Computer Interface	1.2.1 Give Feedback 1.2.2 Accept Input
Continued on next page	

Table L.1 – continued from previous page

Entities, Attributes, and Relationships	Description
1.3 Provide Field Communication	1.3.1 Transmit ISR Information 1.3.2 Receive Directives 1.3.3 Modulate ISR Information 1.3.4 De-Modulate Directives
1.4 Perform Human Operator Functions	1.4.1 Route Info 1.4.2 Process Info 1.4.3 Influence System 1.4.4 Maintain System
1.5 Provide MAV Ground Communication	1.5.1 Modulate MAV Directives 1.5.2 Transmit MAV Directives 1.5.3 De-Modulate Data 1.5.4 Receive Data
2.1 Provide Airborne Communication	2.1.1 Transmit Data 2.1.2 Receive MAV Directives 2.1.3 De-Modulate MAV Directives 2.1.4 Accept Supplied Power 2.1.5 Modulate Data
2.2 Perform Air Vehicle Functions	2.2.1 Flight Control 2.2.2 Take Flight 2.2.3 Flight Data Protocol 2.2.4 Power Source
2.3 Perform Payload/ Sensor Functions	2.3.1 Payload Data Protocol 2.3.2 Enable ISR Capability 2.3.3 Convert ISR Data

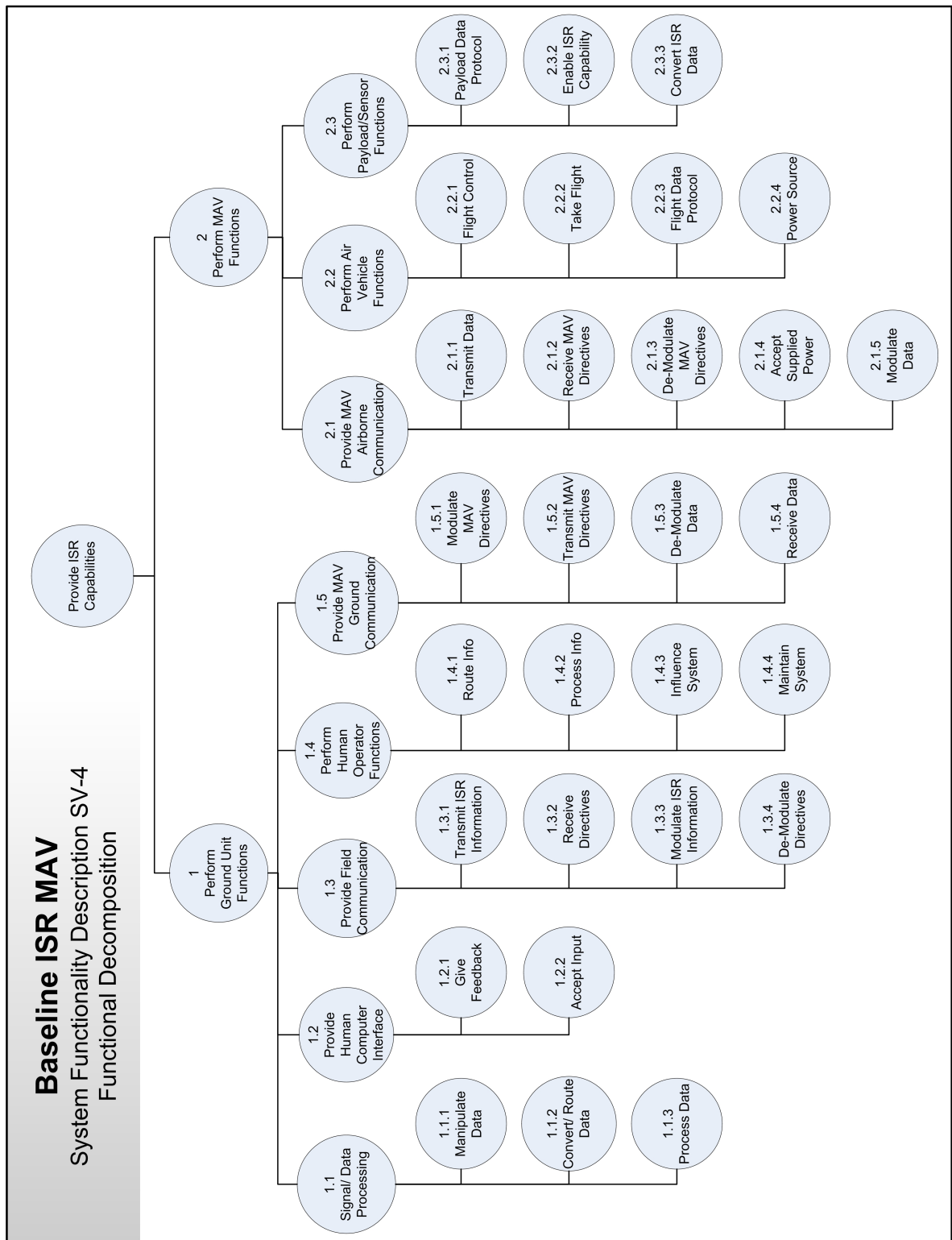

Figure L.1 Functional Decomposition

Baseline ISR MAV

System Functionality Description SV-4
Context Diagram

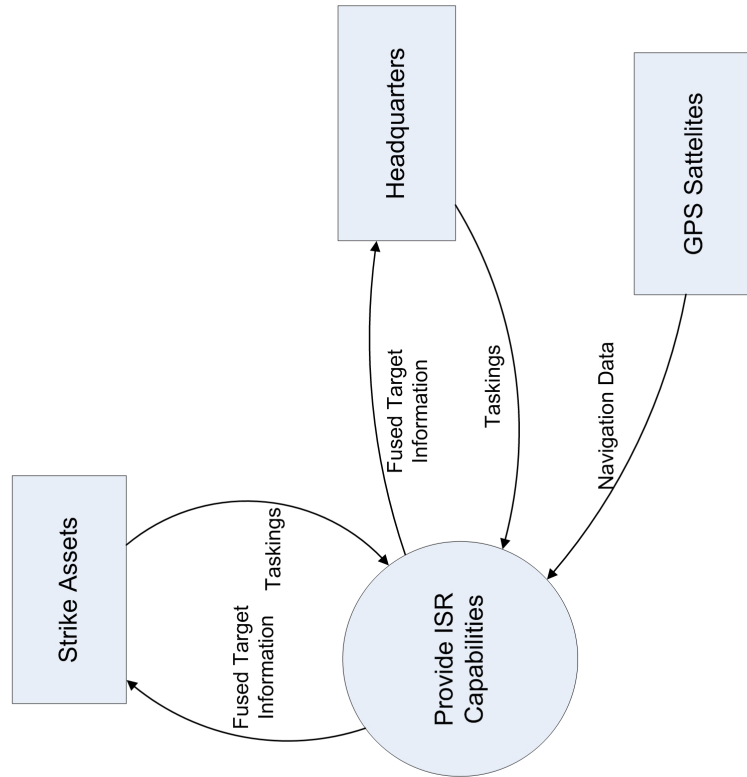

Figure L.2 SV-4 Context Diagram

Baseline ISR MAV
 System Functionality Description SV-4
 0-Level Diagram

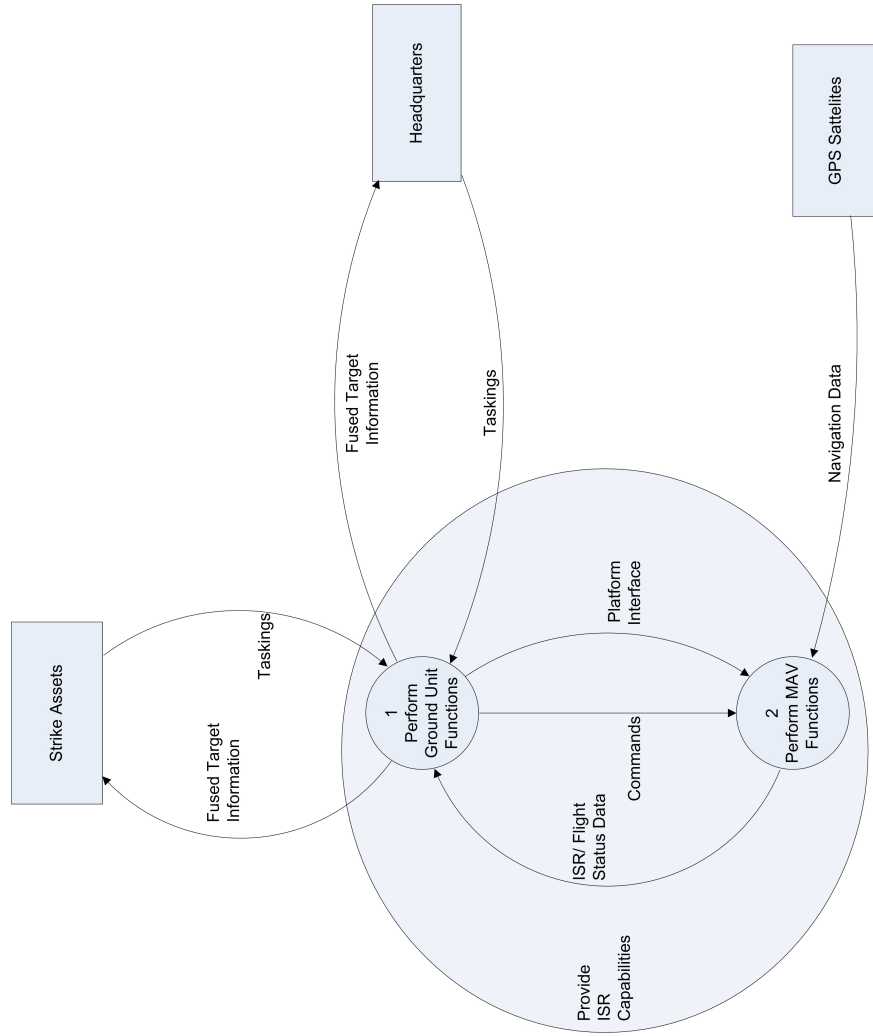

Figure L.3 SV-4 Level 0 Diagram

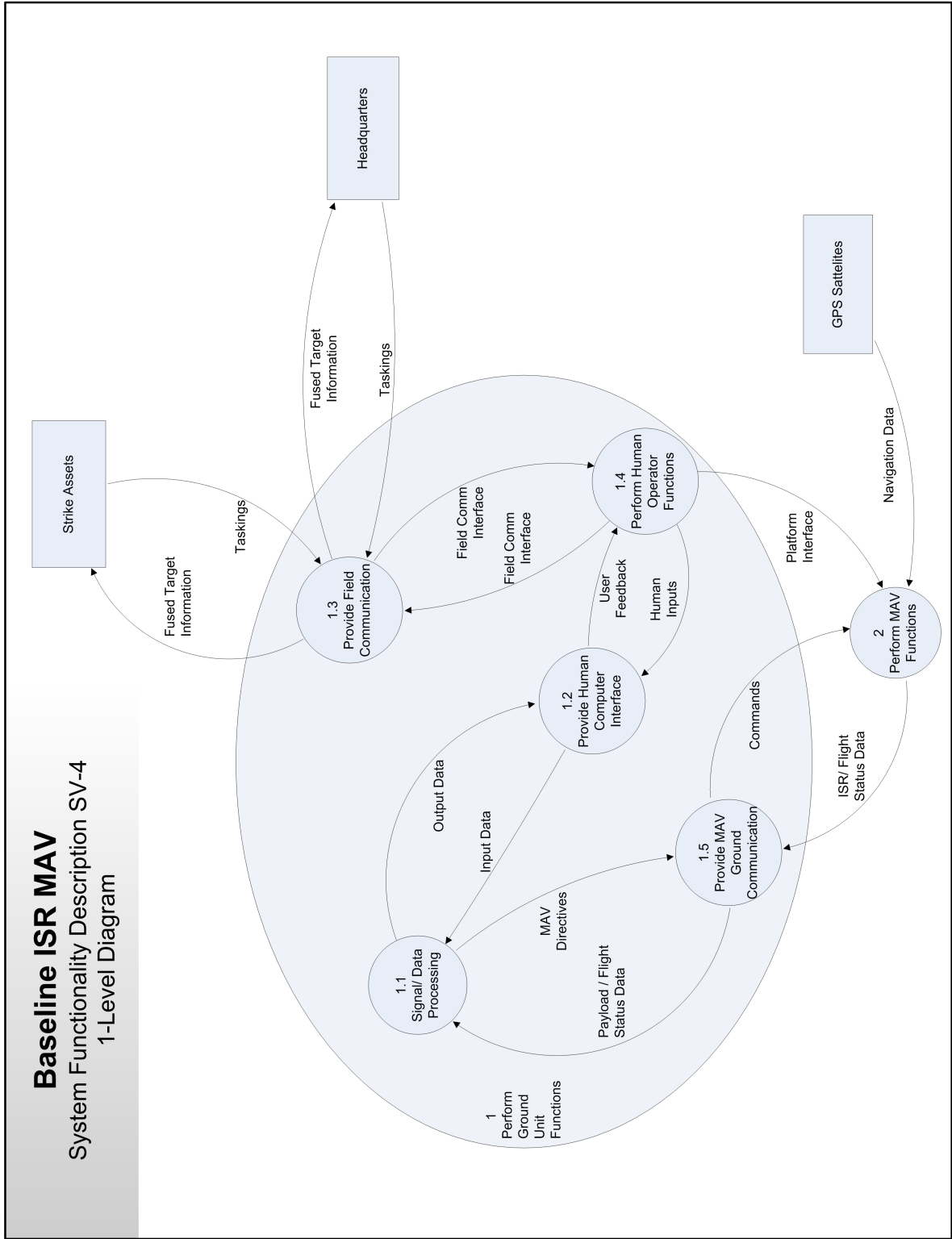

Figure L.4 SV-4 Level 1 Diagram

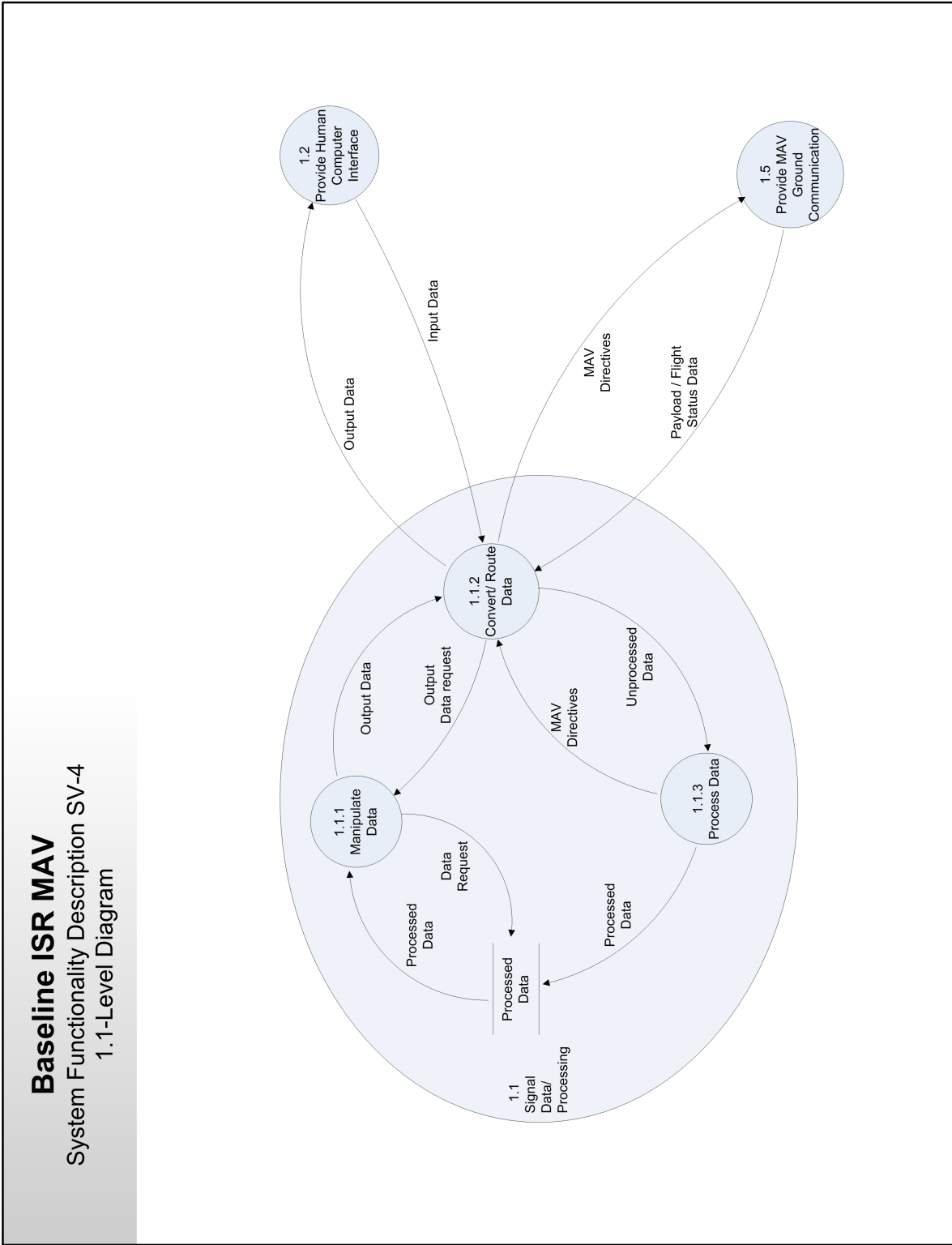

Figure L.5 SV-4 Level 1-1 Diagram

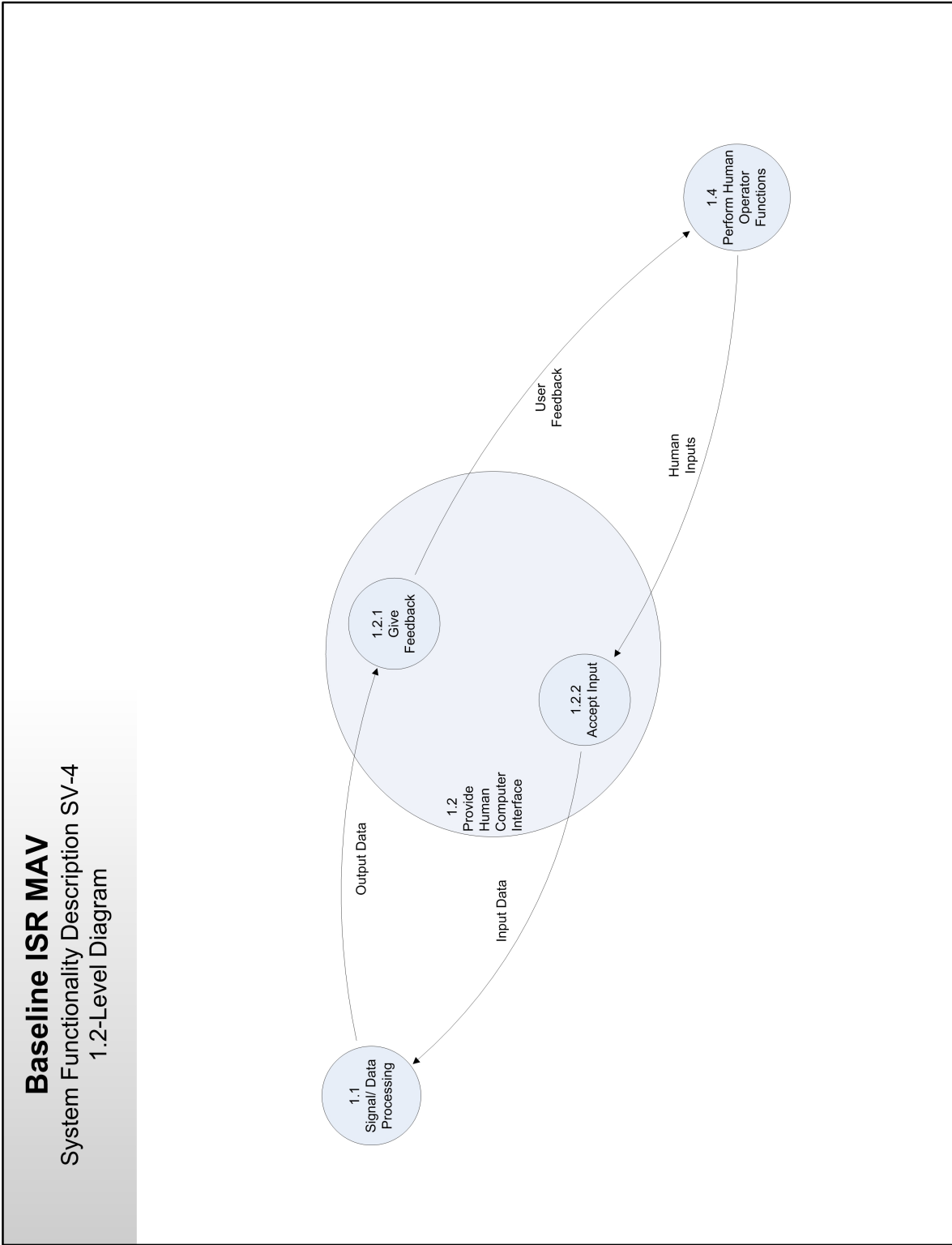

Figure L.6 SV-4 Level 1-2 Diagram

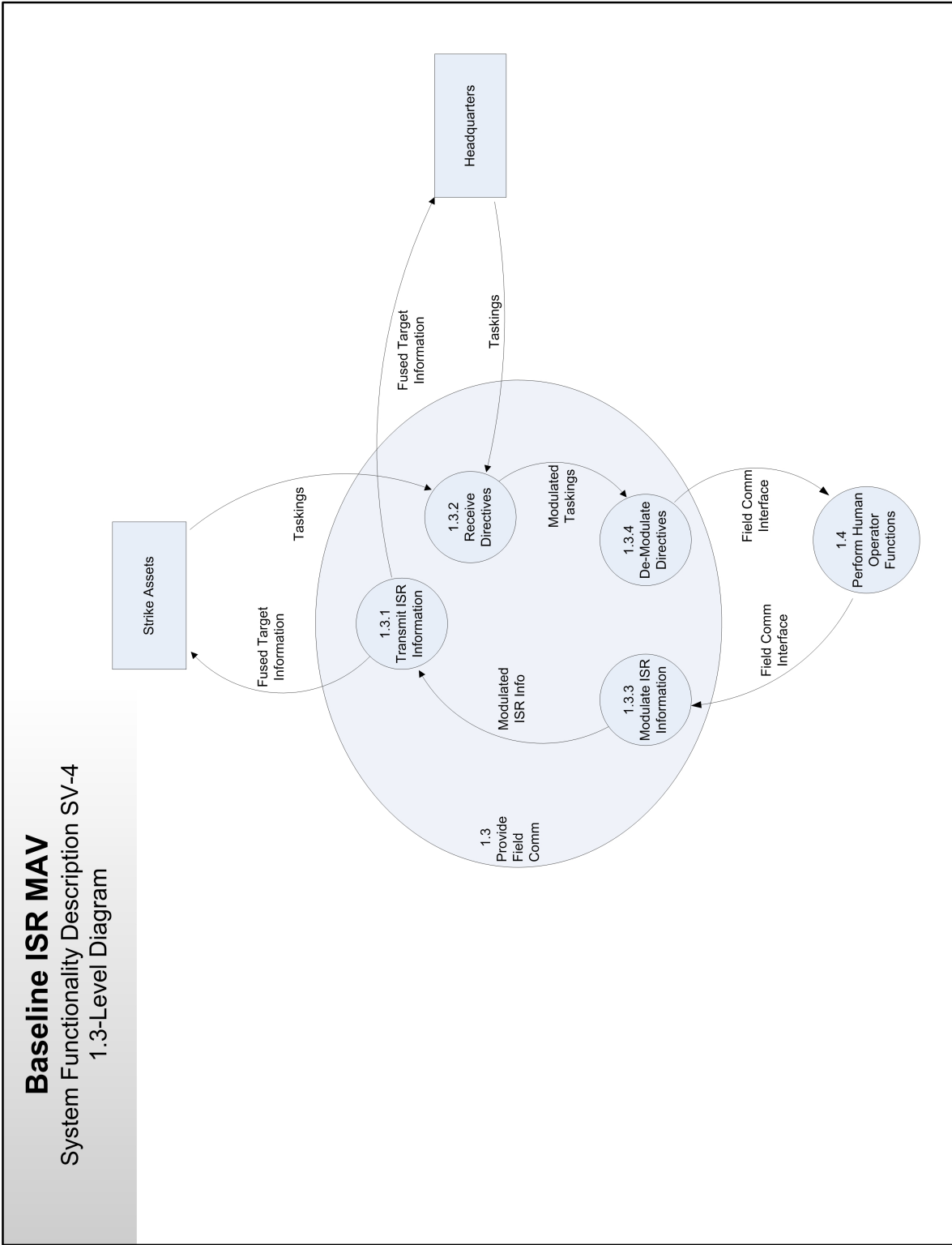

Figure L.7 SV-4 Level 1-3 Diagram

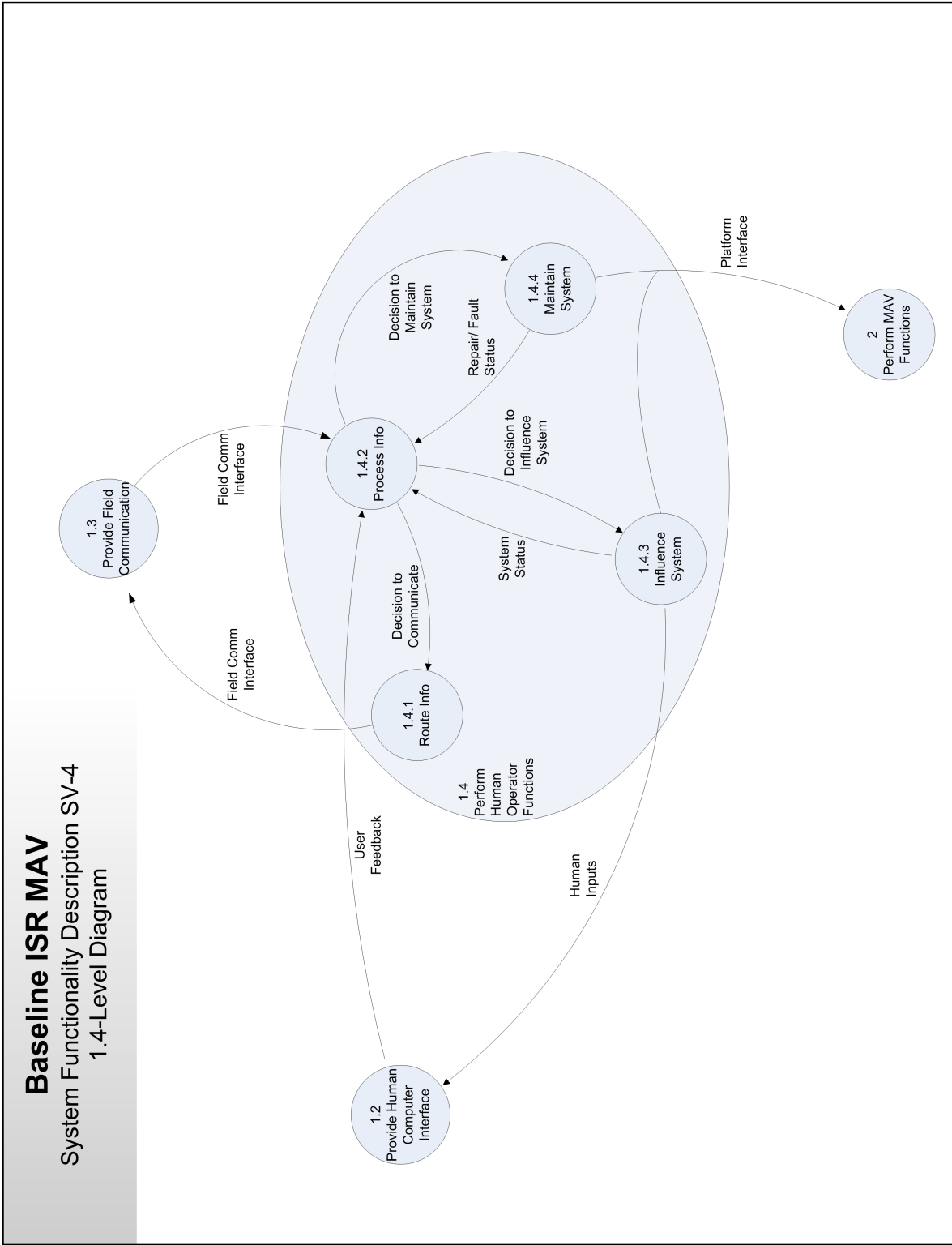

Figure L.8 SV-4 Level 1-4 Diagram

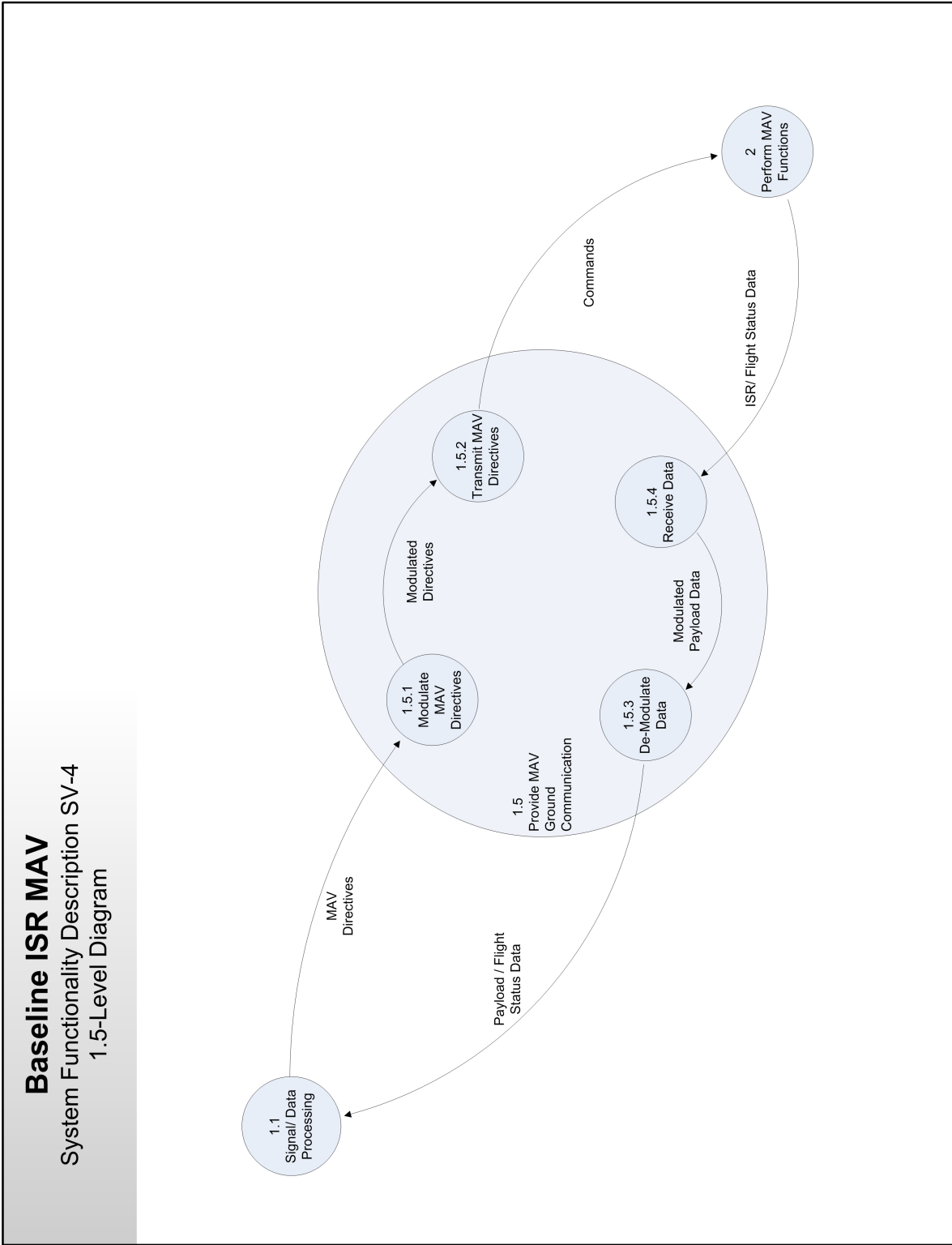

Figure L.9 SV-4 Level 1-5 Diagram

Baseline ISR MAV
 System Functionality Description, SV-4
 2-Level Diagram

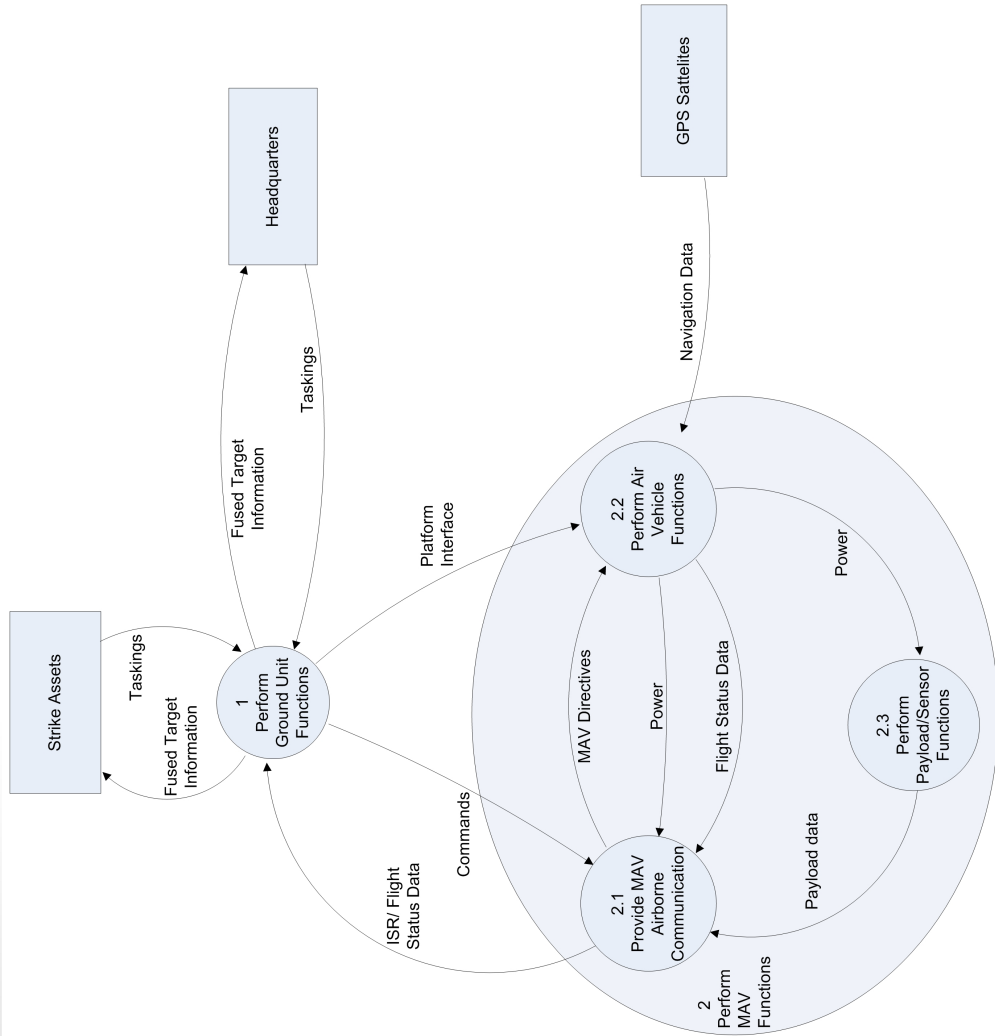

Figure L.10 SV-4 Level 2 Diagram

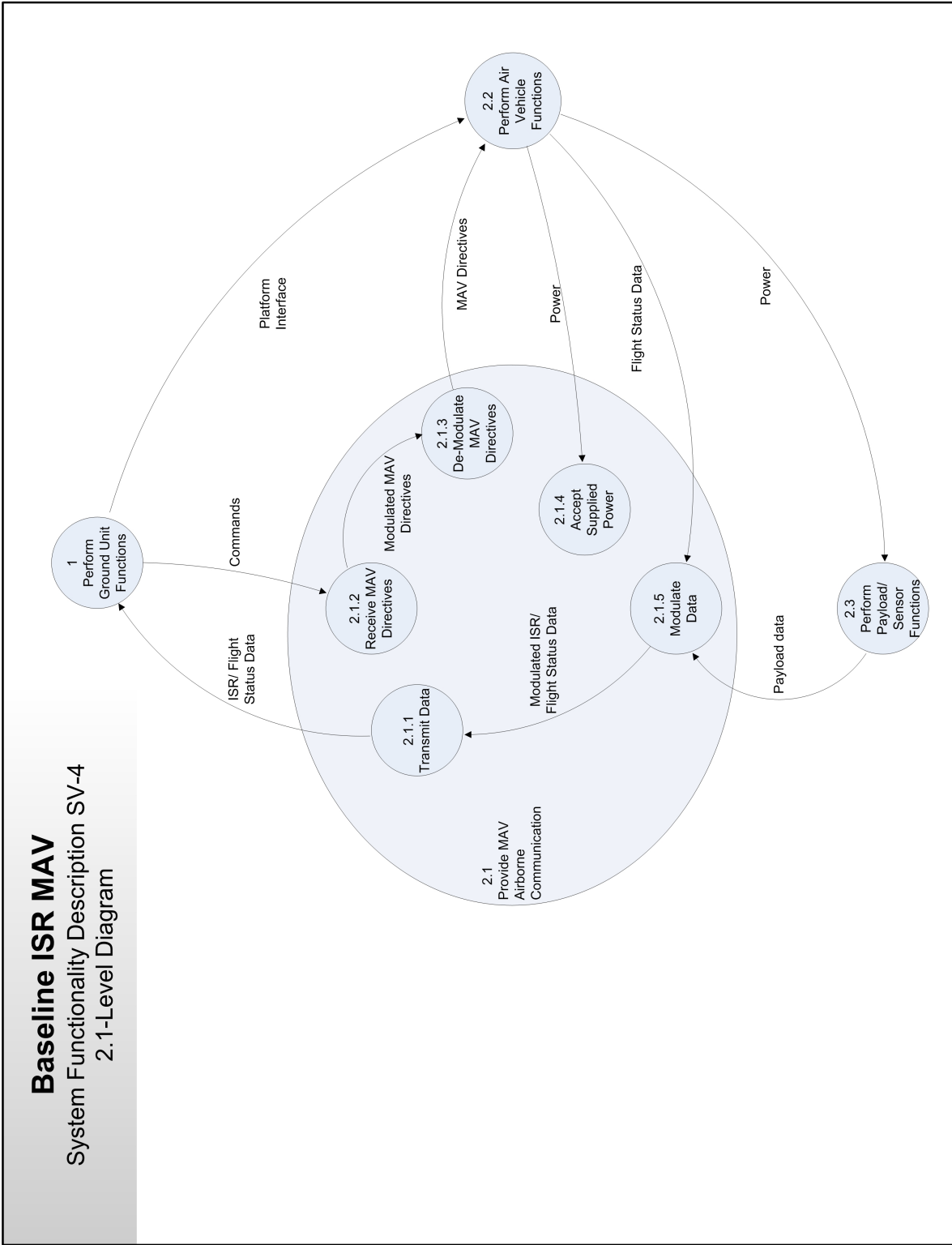

Figure L.11 SV-4 Level 2-1 Diagram

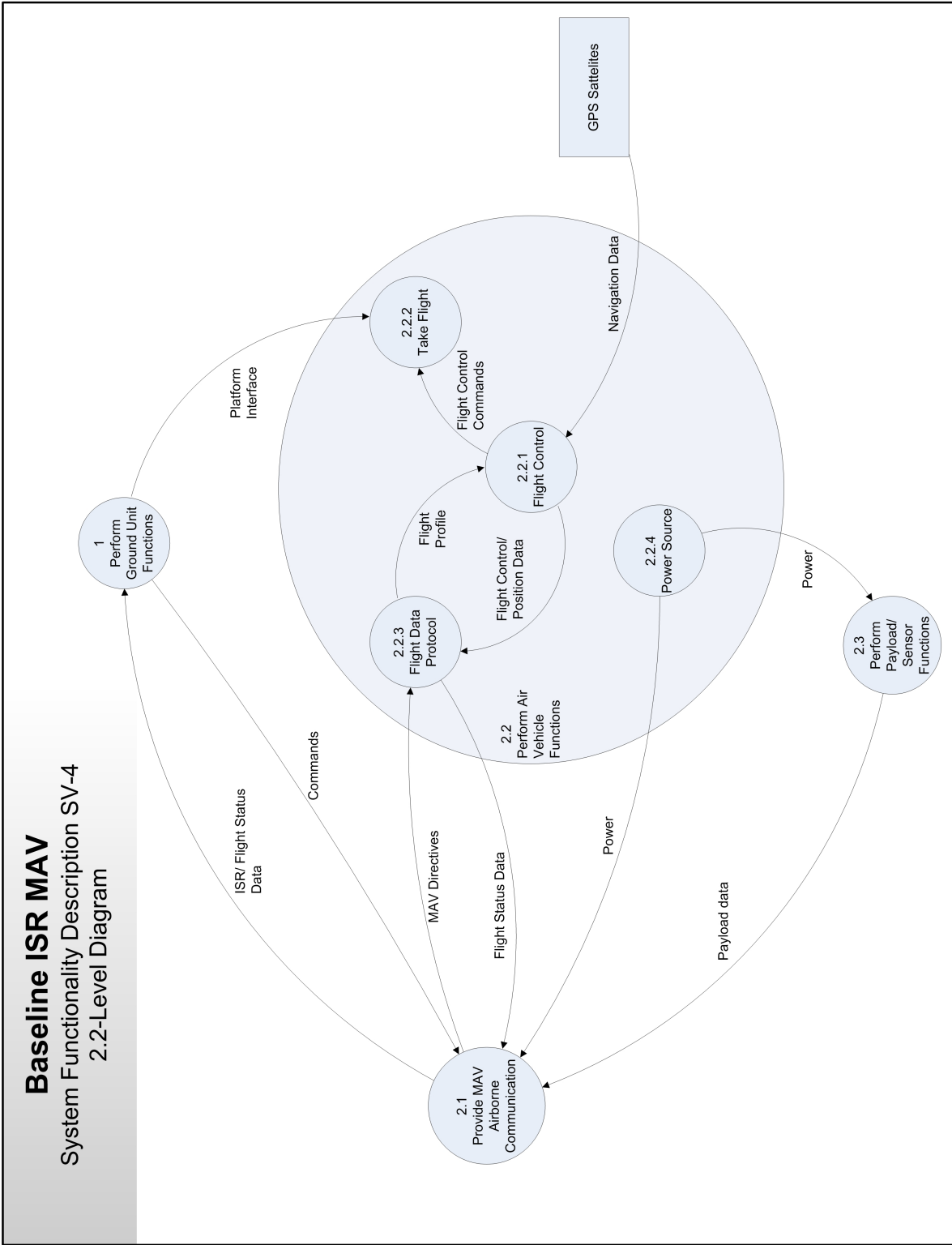

Figure L.12 SV-4 Level 2-2 Diagram

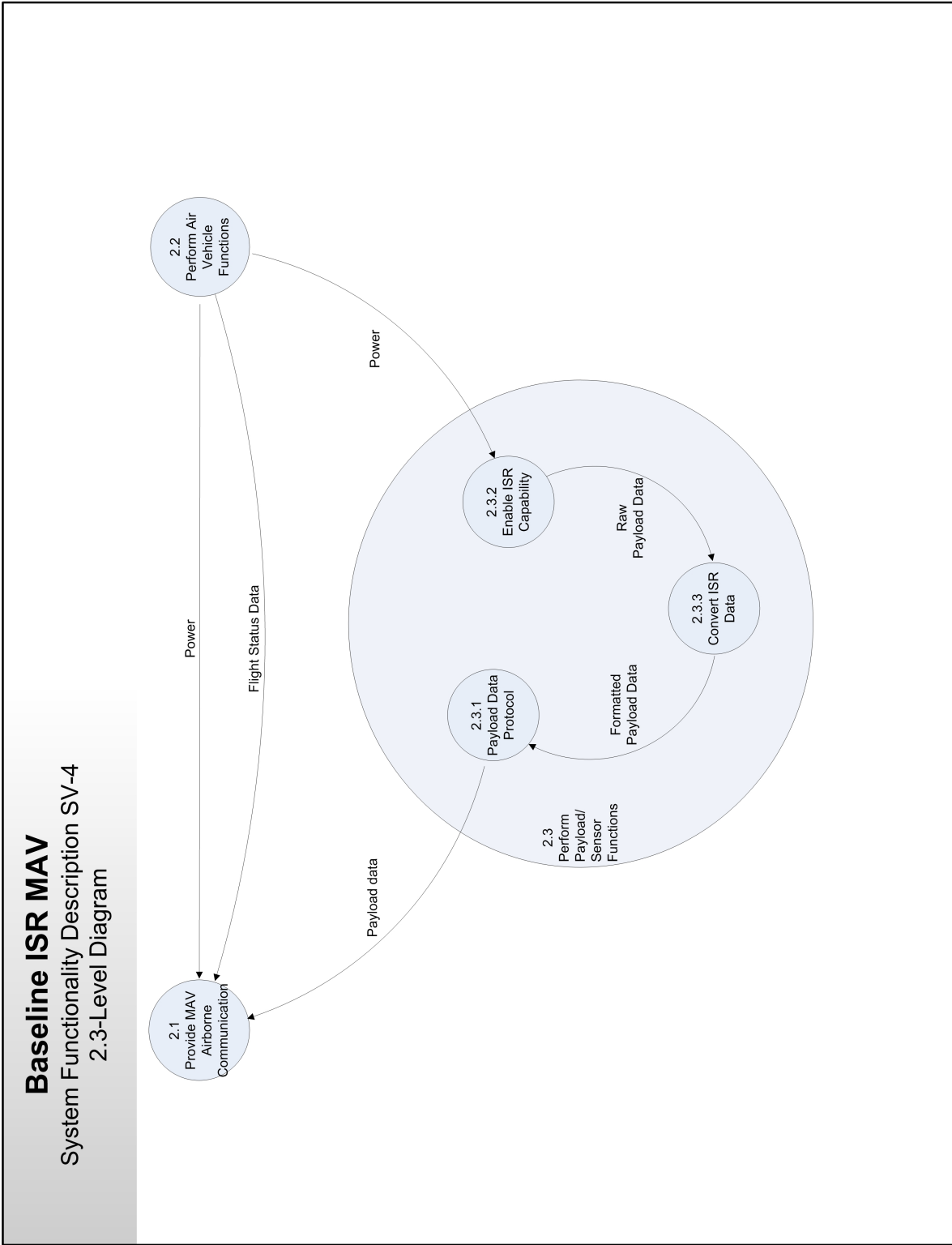

Figure L.13 SV-4 Level 2-3 Diagram

Appendix M. MAV SV-5

Table M.1 – AV-2 Integrated Dictionary

Entities, Attributes, and Relationships	Description
	Reference Types
Capabilities	See OV-5 Definition Table
Systems	See SV-1 Definition Table
Operational Activities	See OV-5 Definition Table
System Functions	See SV-1 Definition Table
	Relationships
Supporting System Function	Operational Activity for a Capability
Accept Input	Operational Activity: Process Information System Name: Human Computer Interface Capability Name: Perform Reconnaissance, BDI, and LAD Support Status Code: Application Specific
Accept Supplied Power	Operational Activity: Provides Flight Controls, Enables Sensor Package System Name: MAV Airborne Communication System Capability Name: Perform Reconnaissance, BDI, and LAD Support Status Code: Application Specific
Convert/Route Data	Operational Activity: Provides Vehicle Control and Communication, Initialize MAV, Calibrate MAV, Upload Mission Profile System Name: Signal/Data Processor Capability Name: Perform Reconnaissance, BDI, and LAD Support Status Code: Application Specific
Convert ISR Data	Operational Activity: Enables Sensor Package System Name: Payload or Sensor Package Capability Name: Perform Reconnaissance, BDI, and LAD Support Status Code: Application Specific
De-Modulate Data	Operational Activity: Provides Vehicle Control and Communication System Name: MAV Ground Communication System
Continued on next page	

Table M.1 – continued from previous page

Entities, Attributes, and Relationships	Description
	Capability Name: Perform Reconnaissance, BDI, and LAD Support Status Code: Application Specific
De-Modulate Directives	Operational Activity: Process Information System Name: Field Communication System Capability Name: Perform Reconnaissance, BDI, and LAD Support Status Code: Application Specific
De-Modulate MAV Directives	Operational Activity: Provides Flight Controls, Enables Sensor Package System Name: MAV Airborne Communication System Capability Name: Perform Reconnaissance, BDI, and LAD Support Status Code: Application Specific
Enable ISR Capability	Operational Activity: Enables Sensor Package System Name: Payload or Sensor Package Capability Name: Perform Reconnaissance, BDI, and LAD Support Status Code: Application Specific
Flight Control	Operational Activity: Provides Flight Controls, Calculate Flight Plan to Landing Zone, Fly to Landing Zone, Perform Landing Sequence System Name: Air Vehicle Capability Name: Perform Reconnaissance, BDI, and LAD Support Status Code: Application Specific
Flight Data Protocol	Operational Activity: Provides Flight Controls System Name: Air Vehicle Capability Name: Perform Reconnaissance, BDI, and LAD Support Status Code: Application Specific
Give Feedback	Operational Activity: Process Information System Name: Human Computer Interface Capability Name: Perform Reconnaissance, BDI, and LAD Support Status Code: Application Specific
Continued on next page	

Table M.1 – continued from previous page

Entities, Attributes, and Relationships	Description
Influence System	Operational Activity: Initialize MAV, Calibrate MAV, Upload Mission Profile, Launch MAV, Recover MAV System Name: Human Operator Capability Name: Perform Reconnaissance, BDI, and LAD Support Status Code: Application Specific
Maintain System	Operational Activity: Provide Field Level Maintenance System Name: Human Operator Capability Name: Perform Reconnaissance, BDI, and LAD Support Status Code: Application Specific
Manipulate Data	Operational Activity: Provides Vehicle Control and Communication, Initialize MAV, Calibrate MAV, Upload Mission Profile System Name: Signal/Data Processor Capability Name: Perform Reconnaissance, BDI, and LAD Support Status Code: Application Specific
Modulate Data	Operational Activity: Provides Flight Controls, Enables Sensor Package System Name: MAV Airborne Communication System Capability Name: Perform Reconnaissance, BDI, and LAD Support Status Code: Application Specific
Modulate ISR Information	Operational Activity: Process Information System Name: Field Communication System Capability Name: Perform Reconnaissance, BDI, and LAD Support Status Code: Application Specific
Modulate MAV Directives	Operational Activity: Provides Vehicle Control and Communication, Calibrate MAV System Name: MAV Ground Communication System Capability Name: Perform Reconnaissance, BDI, and LAD
Continued on next page	

Table M.1 – continued from previous page

Entities, Attributes, and Relationships	Description
	Support Status Code: Application Specific
Payload Data Protocol	Operational Activity: Enables Sensor Package System Name: Payload or Sensor Package Capability Name: Perform Reconnaissance, BDI, and LAD Support Status Code: Application Specific
Power Source	Operational Activity: Provides Flight Vehicle System Name: Air Vehicle Capability Name: Perform Reconnaissance, BDI, and LAD Support Status Code: Application Specific
Process Data	Operational Activity: Provides Vehicle Control and Communication, Initialize MAV, Calibrate MAV, Upload Mission Profile System Name: Signal/Data Processor Capability Name: Perform Reconnaissance, BDI, and LAD Support Status Code: Application Specific
Process Info	Operational Activity: Process Information System Name: Human Operator Capability Name: Perform Reconnaissance, BDI, and LAD Support Status Code: Application Specific
Receive Data	Operational Activity: Provides Vehicle Control and Communication System Name: MAV Ground Communication System Capability Name: Perform Reconnaissance, BDI, and LAD Support Status Code: Application Specific
Receive Directives	Operational Activity: Process Information System Name: Field Communication System Capability Name: Perform Reconnaissance, BDI, and LAD Support Status Code: Application Specific
Receive MAV Directives	Operational Activity: Provides Flight Controls, Enables Sensor Package
Continued on next page	

Table M.1 – continued from previous page

Entities, Attributes, and Relationships	Description
	System Name: MAV Airborne Communication System Capability Name: Perform Reconnaissance, BDI, and LAD Support Status Code: Application Specific
Route Info	Operational Activity: Process Information System Name: Human Operator Capability Name: Perform Reconnaissance, BDI, and LAD Support Status Code: Application Specific
Take Flight	Operational Activity: Provides Flight Vehicle, Fly to Landing Zone, Perform Landing Sequence System Name: Air Vehicle Capability Name: Perform Reconnaissance, BDI, and LAD Support Status Code: Application Specific
Transmit Data	Operational Activity: Provides Flight Controls, Enables Sensor Package System Name: MAV Airborne Communication System Capability Name: Perform Reconnaissance, BDI, and LAD Support Status Code: Application Specific
Transmit ISR Information	Operational Activity: Process Information System Name: Field Communication System Capability Name: Perform Reconnaissance, BDI, and LAD Support Status Code: Application Specific
Transmit MAV Directives	Operational Activity: Provides Vehicle Control and Communication, Calibrate MAV System Name: MAV Ground Communication System Capability Name: Perform Reconnaissance, BDI, and LAD Support Status Code: Application Specific
Implementing System Function	Operational Activity
Accept Input	Process Information
Continued on next page	

Table M.1 – continued from previous page

Entities, Attributes, and Relationships	Description
Accept Supplied Power	Provides Flight Controls, Enables Sensor Package
Convert/Route Data	Provides Vehicle Control and Communication, Initialize MAV, Calibrate MAV, Upload Mission Profile
Convert ISR Data	Enables Sensor Package
De-Modulate Data	Provides Vehicle Control and Communication
De-Modulate Directives	Process Information
De-Modulate MAV Directives	Provides Flight Controls, Enables Sensor Package
Enable ISR Capability	Enables Sensor Package
Flight Control	Provides Flight Controls, Calculate Flight Plan to Landing Zone, Fly to Landing Zone, Perform Landing Sequence
Flight Data Protocol	Provides Flight Controls
Give Feedback	Process Information
Influence System	Initialize MAV, Calibrate MAV, Upload Mission Profile, Launch MAV, Recover MAV
Maintain System	Provide Field Level Maintenance
Manipulate Data	Provides Vehicle Control and Communication, Initialize MAV, Calibrate MAV, Upload Mission Profile
Modulate Data	Provides Flight Controls, Enables Sensor Package
Modulate ISR Information	Process Information
Modulate MAV Directives	Provides Vehicle Control and Communication, Calibrate MAV
Payload Data Protocol	Enables Sensor Package
Power Source	Provides Flight Vehicle
Process Data	Provides Vehicle Control and Communication, Initialize MAV, Calibrate MAV, Upload Mission Profile
Process Info	Process Information
Receive Data	Provides Vehicle Control and Communication
Receive Directives	Process Information
Receive MAV Directives	Provides Flight Controls, Enables Sensor Package
Route Info	Process Information
Take Flight	Provides Flight Vehicle, Fly to Landing Zone, Perform Landing Sequence
Transmit Data	Provides Flight Controls, Enables Sensor Package
Continued on next page	

Table M.1 – continued from previous page

Entities, Attributes, and Relationships	Description
Transmit ISR Information	Process Information
Transmit MAV Directives	Provides Vehicle Control and Communication, Calibrate MAV

System		Capability to perform Recon, BDI, and LAD														
		Information Processing		Launch MAV				ISR MAV Platform			Recover MAV				Provide Field Level Maintenance	
		Op Activity	System Function	Process Information	Provides Vehicle Control and Communication	Initialize MAV	Calibrate MAV	Upload Mission Profile	Launch MAV	Provides Flight Controls	Provides Flight Vehicle	Enables Sensor Package	Calculate Flight Plan to Landing Zone	Fly to Landing Zone		Perform Landing Sequence
Human Operator	Process Info															
	Influence System															
	Route Info															
	Maintain System															
Field Communication System	Transmit ISR Information															
	Receive Directives															
	Modulate ISR Information															
	De-Modulate Directives															
Human Computer Interface	Give Feedback															
	Accept Input															
Signal/Data Processor	Convert/Route Data															
	Process Data															
	Manipulate Data															
MAV Ground Communication System	Transmit MAV Directives															
	Receive Data															
	Modulate MAV Directives															
	De-Modulate Data															

Figure M.1 SV-5 Operational Activity to System Functions Traceability Matrix 1

System		Capability to perform Recon, BDI, and LAD														
		System Function	Information Processing		Launch MAV				ISR MAV Platform			Recover MAV			Provide Field Level Maintenance	
			Op Activity	Process Information	Provides Vehicle Control and Communication	Initialize MAV	Calibrate MAV	Upload Mission Profile	Launch MAV	Provides Flight Controls	Provides Flight Vehicle	Enables Sensor Package	Calculate Flight Plan to Landing Zone	Fly to Landing Zone		Perform Landing Sequence
Air Vehicle	Take Flight															
	Flight Control															
	Power Source															
	Flight Data Protocol															
Payload or Sensor Package	Enable ISR Capability															
	Convert ISR Data															
	Payload Data Protocol															
MAV Airborne Communication System	Transmit Data															
	Receive MAV Directives															
	Modulate Data															
	Accept Supplied Power															
	De-Modulate MAV Directives															

Figure M.2 SV-5 Operational Activity to System Functions Traceability Matrix 2

Appendix N. MAV SV-6

As outlined in Section 3.2.3, the SV-6 is a matrix with a set of rows and columns where their intersections contain interface information. The rows contain all information contained within a particular interface exchange. Since the relationship between system interfaces and system data exchanges are one-to-many they are categorized first by the system interface name shown in all versions of the SV-1 and then by the system data exchange name which can be SV-6 unique but in this case correlates to the OV-3s information exchange names. The columns show specific information based on the columns heading. Many times, the column headings are tailored to the specific system type that is being modeled. A template for a highly complex, secure, and detailed communication system may have many extraneous columns for a simpler system with fewer interfaces. The tailored list below is the column headings with their meanings as defined by DoDAF [24]. The columns outside the scope of this initial baseline architecture have been marked Left Blank. This research will still show these empty columns in order to allow for future detailed research. Following the column definitions are the SV-6 matrix figures completed for the Baseline ISR MAV.

Row ID: Contains a unique row number for each row and is used for easier referencing (instead of having to recite the system data exchange name).

System Interface Name: Identifies the system interface as shown in the SV-1 system interface description diagram that carries the system data exchange.

System Data Exchange Name: Name of the system data exchange, based on the relevant operational needline, system interface, and information element. This research will correlate this column with the information exchange name in the OV-3 matrix.

Data Element Name and ID: Name of the system data element, primarily based on the SV-4 system data flow and can correlate to the OV-3 information element. The MAV baseline architecture will correlate this column with the OV-3 information

element, which ends up mapping back to the OV-5 and OV-7 diagrams.

Content: The system data that is carried by the exchange.

Format Type: Application level format (e.g., XML/DTD, EDI, ASCII Text) with parameters and options used, or other relevant protocol. *Left Blank*

Media Type: Type of media. *Left Blank*

Accuracy: Description of the degree to which the system data conforms to actual fact as required by the system or system function. *Left Blank*

Units of Measurement: Units used for system data. *Left Blank*

Data Standard: An example is DoD XML Registry, can reference TV-1 or TV-2 definition tables if produced (this research does not produce any TV's). *Left Blank*

Sending System Name: Name of the system from the SV-1 that produces the system data.

Sending System Function Name: The name of the system function, as shown in the SV-1, producing the system data.

Receiving System Name: Name of the system from the SV-1 that consumes the system data.

Receiving System Function Name: The name of the system function, as shown in the SV-1, consuming the system data.

Transaction Type: Descriptive field that identifies the type of exchange.

Triggering Event: Brief textual description of the event that triggers the system data exchange as shown in the SV-10. If triggering events are not included in the SV-10 or no SV-10 exists (in this case none exists) then this column is not required however an example of such a event can be given as the case with this research.

Interoperability Level Required (from C4ISR WG): Level of Information Systems Interoperability (LISI), or other interoperability measure. This research

used the C4ISR Working Groups [10] interoperability levels. There are 5 possible levels of interoperability an information exchange can have, numbered 0 to 4. Level 0 is termed the Isolated Level and consists of manual access control procedures, manual infrastructure and private data. Level 1 is termed the Connected Level and consists of a security profile, two or one way infrastructure, and basic data formats. Level 2 is termed the Functional Level and consists of a common operating environment, a local area network (LAN) infrastructure, program models, and advanced data formats. Level 3 is termed the Domain Level and consists of domain procedures, a wide area network (WAN), database management system (DBMS), and domain models. Level 4 consists of enterprise procedures (DoD, Multi-National), multiple dimensional topologies, and cross enterprise models.

Criticality: The criticality assessment of the information being exchanged in relationship of the mission being performed, meaning how essential is it to the overall mission or capability.

Periodicity: Frequency of system data exchange transmission, may be an average or worst case estimate and can include conditions.

Timeliness: How much delay this system data can tolerate and still be relevant to the receiving system. This research uses *in minutes* and *in seconds* to state the order of measurement to be used.

Throughput: Bits or bytes per time period, may be expressed in terms of maximum or average throughput required. *Left Blank*

Size: Size of system data. *Left Blank*

Access Control: The class of mechanisms used to ensure only those authorized can access a specific system data element. *Left Blank*

Availability: The relative level of effort required to be expended to ensure that the system data can be accessed. *Left Blank*

Confidentiality: The kind of protection required for system data to prevent unintended disclosure. *Left Blank*

Dissemination Control: The kind of restrictions on receivers of system data based on sensitivity of system data. *Left Blank*

Integrity: The kind of requirement for checks that the content of the system data element has not been altered. *Left Blank*

Non-Repudiation Producer: The requirements for unassailable knowledge that the system data received was produced by the stated source. *Left Blank*

Non-Repudiation Consumer: The requirements for unassailable knowledge that the system data sent was consumed by the intended recipient. *Left Blank*

Protection (Type, Name, Duration, Date): The name for the type of protection, the code that represents how long the system data must be safeguarded, and the calendar date on which the designated level of safeguarding discontinues for a specific system data element. *Left Blank*

Classification: Classification code for the system data element. *Left Blank*

Classification Caveat: A set of restrictions on system data of a specific classification. Supplements a security classification with system data on access, dissemination, and other types of restrictions. *Left Blank*

Releasability: The code that represents the kind of controls required for further dissemination of system data. *Left Blank*

Security Standard: Defined by completed TV architectural views. *Left Blank*

Row ID						
4	3	2	1	System Interface Name	Interface Identifier	
				System Data Exchange Name	Data Exchange Identifier	
Feedback and Input Data	Feedback and Input Data	BDI Request and Feedback	BDI Request and Feedback	Data Element Name	Data Description	
				Input Data		Feedback Signal
Flight Plan	Decoded Sensor Package Data	Tasking	Fused Target Information			Format Type
Keyboard, Mouse, Touch Screen Signals	Audio and Video Signals	BDI Type, Enemy Positions, Status/Type of Strike	BDI Confirmation and general ISR information gathered			Media Type
						Accuracy
						Units of Measurement
						Data Standard
Human Computer Interface	Signal/Data Processor	Strike Assets	Field Communication System	Sending System Name	Producer	
Accept Input	Convert/Route Data	N/A	Transmit ISR Info	Sending System Function Name	Consumer	
Signal/Data Processor	Human Computer Interface	Field Communication System	Strike Assets	Receiving System Name		
Process Data	Give Feedback	Receive Directives	N/A	Receiving System Function Name	Nature of Transaction	
Intermode Hardware Connection	Intermode Hardware Connection	Voice Transmission	Voice Transmission	Transaction Type		
HCI detects input	Processor Sends Feedback Signal	Strike Asset cannot perform BDI therefore request a BDI mission	User needs to communicate to Strike Assets	Triggering Event		
Level 1 Connected (Peer-to-Peer)	Level 1 Connected (Peer-to-Peer)	Level 0 Isolated (Manual)	Level 0 Isolated (Manual)	Interoperability Level Achieved (C4ISR WG)		
Mission Essential	Mission Essential	Mission Essential	Can increase mission effectiveness	Criticality		
Varies by user and mission (at least twice)	Feedback constantly being supplied	Does not occur often however it depends on the battlefield situation	Does not occur often however it depends on the battlefield situation	Periodicity	Performance Attributes	
Input in seconds	Feedback in seconds	Depends on method of delivery (in minutes)	Depends on method of delivery (in minutes)	Timeliness		
				Throughput	Information Assurance	
				Size		
				Access Control		
				Availability		
				Confidentiality		
				Dissemination Control		
				Integrity		
				Non-Repudiation Producer		
				Non-Repudiation Consumer		
				Protection (Type, Name, Duration, Date)		Security
				Classification		
				Classification Caveat		
				Releasability		
				Security Standard		

Figure N.1 SV-6 Systems Data Exchange Matrix 1

8	7	6	5	Row ID	
				Interface Identifier	Data Exchange Identifier
Information Gathered, Mission Task, Intelligence Info	Information Gathered, Mission Task, Intelligence Info	Field Comm Interface	Field Comm Interface	System Interface Name	
Intelligence Information	Information Gathered	Send Communication	Receive Communication	System Data Exchange Name	
Tasking	Fused Target Information	Fused Target Information	Tasking	Data Element Name	
Regional Intelligence and Enemy Positions	Enemy Positions, Collected ISR Data	Enemy Positions, Collected ISR Data	Taskings, BDI Request, Intelligence Info	Content	
				Format Type	
				Media Type	
				Accuracy	
				Units of Measurement	
				Data Standard	
Headquarters	Field Communication System	Human Operator	Field Communication System	Sending System Name	Producer
N/A	Transmit ISR Info	Route Info	De-Modulate Directives	Sending System Function Name	
Field Communication System	Headquarters	Field Communication System	Human Operator	Receiving System Name	Consumer
Receive Directives	N/A	Modulate ISR Info	Process Info	Receiving System Function Name	
Data or Voice Transmission	Data or Voice Transmission	Data or Voice Transmission	Voice/Data Transmission	Transaction Type	Nature of Transaction
Updated intelligence information is available through Headquarters	User wishes to forward gathered ISR information to Headquarters	User wishes to send information to Headquarters	Received Communication	Triggering Event	
Level 0 Isolated (Manual)	Level 0 Isolated (Manual)	Level 1 Connected (Peer-to-Peer)	Level 1 Connected (Peer-to-Peer)	Interoperability Level Achieved (C4ISR WG)	
Needed to increase Mission effectiveness	Mission Essential	Mission Essential	Mission Essential	Criticality	
Occurs at the beginning of a mission and may be updated during mission	Depends on mission, may only occur a few times	Usually at end of mission (can occur during)	Usually at beginning of mission	Periodicity	Performance Attributes
Depends on method of delivery (in minutes)	Depends on level of ISR requested (in minutes)	Send in minutes	Receive in minutes	Timeliness	
				Throughput	
				Size	
				Access Control	
				Availability	
				Confidentiality	
				Dissemination Control	
				Integrity	
				Non-Repudiation Producer	
				Non-Repudiation Consumer	
				Protection (Type, Name, Duration, Date)	
				Classification	
				Classification Caveat	
				Releasability	
				Security Standard	

Figure N.2 SV-6 Systems Data Exchange Matrix 2

12	11	10	9	Row ID	Interface Identifier	Data Exchange Identifier	Data Description	Producer	Consumer	Nature of Transaction	Performance Attributes	Information Assurance	Security
MAV Directives and Payload Data	Maintenance Required	Maintenance Required	Information Gathered, Mission Task, Intelligence Info		System Interface Name	System Data Exchange Name							
MAV Directives	Maintenance Request	Completed Maintenance	Mission Tasks										
User Commands	Maintain MAV System	Maintain MAV System	Tasking		Data Element Name								
Platform Mission Profile and Directives	Request for maintenance to be performed on the system	Acknowledgement of completed maintenance	Mission Type, Waypoints, Goals		Content								
					Format Type								
					Media Type								
					Accuracy								
					Units of Measurement								
					Data Standard								
Signal/Data Processor	Human Operator	Maintenance Depot	Headquarters		Sending System Name								
Convert/Route Data	Maintain System	N/A	N/A		Sending System Function Name								
MAV Ground Communication System	Maintenance Depot	Human Operator	Field Communication System		Receiving System Name								
Modulate MAV Directives	N/A	Maintain System	Receive Directives		Receiving System Function Name								
Intermode Hardware Connection	Voice Transmission	Voice Transmission	Voice Transmission		Transaction Type								
Outgoing Directives Available	System needs non-field level maintenance performed	System maintenance complete	Headquarters wishes to assign an ISR task		Triggering Event								
Level 1 Connected (Peer-to-Peer)	Level 0 Isolated (Manual)	Level 0 Isolated (Manual)	Level 0 Isolated (Manual)		Interoperability Level Achieved (C4ISR WG)								
Mission Essential	Can increase mission effectiveness	Can increase mission effectiveness	Mission Essential		Criticality								
Occurs frequently during mission	Depends on usage and system handling	Depends on usage and system handling	Occurs at the beginning of a mission and may be updated during mission		Periodicity								
In Seconds	Depends on method of delivery (in minutes)	Depends on method of delivery (in minutes)	Depends on mission and method of delivery (in minutes)		Timeliness								
					Throughput								
					Size								
					Access Control								
					Availability								
					Confidentiality								
					Dissemination Control								
					Integrity								
					Non-Repudiation Producer								
					Non-Repudiation Consumer								
					Protection (Type, Name, Duration, Date)								
					Classification								
					Classification Caveat								
					Releasability								
					Security Standard								

Figure N.3 SV-6 Systems Data Exchange Matrix 3

16	15	14	13	Row ID	
				Interface Identifier	Data Exchange Identifier
Platform Interface	Payload Data	Navigation Data	MAV Directives and Payload Data	System Interface Name	
Platform Launch	ISR Payload Data	Navigation Information	Payload Data	System Data Exchange Name	
Successful Launch	Raw Sensor Package Data	Navigation Data	Raw Sensor Package Data	Data Element Name	Data Description
Physical Interaction resulting in successful launch	Raw Data from ISR Package	Satellite PRNs and Nav Messages	ISR Data Collected by Sensor Package	Content	
				Format Type	
				Media Type	
				Accuracy	
				Units of Measurement	
				Data Standard	
Human Operator	Payload or Sensor Package	GPS Satellites	MAV Ground Communication System	Sending System Name	Producer
Influence System	Convert ISR Data	N/A	De-Modulate Data	Sending System Function Name	
Air Vehicle	MAV Airborne Communication System	Air Vehicle	Signal/Data Processor	Receiving System Name	Consumer
Take Flight	Modulate Data	Flight Control	Convert/Route Data	Receiving System Function Name	
Physical Interaction	Intermode Hardware Connection	Data Transmission	Intermode Hardware Connection	Transaction Type	Nature of Transaction
Launch Platform	Updated ISR data available	Determined by external node	Incoming Data Available	Triggering Event	
Level 0 Isolated (Manual)	Level 1 Connected (Peer-to-Peer)	Level 1 Connected (Peer-to-Peer)	Level 1 Connected (Peer-to-Peer)	Interoperability Level Achieved (C4ISR WG)	
Mission Essential	Mission Essential	Mission Essential	Mission Essential	Criticality	
Launch varies by mission	Occurs frequently during mission	PRNs and NAV message always being transmitted	Occurs frequently during mission	Periodicity	Performance Attributes
Launch in minutes	In Seconds	Processing time depends on receiver (in seconds)	In Seconds	Timeliness	
				Throughput	
				Size	Information Assurance
				Access Control	
				Availability	
				Confidentiality	
				Dissemination Control	
				Integrity	
				Non-Repudiation Producer	
				Non-Repudiation Consumer	
				Protection (Type, Name, Duration, Date)	Security
				Classification	
				Classification Caveat	
				Releasability	
				Security Standard	

Figure N.4 SV-6 Systems Data Exchange Matrix 4

Row ID				
20	19	18	17	System Interface Name
Power, MAV Directives, and Status Interface	Power Interface	Platform Interface	Platform Interface	System Data Exchange Name
Air Vehicle Directives	Payload Power	Platform Recovery	Platform Maintenance	Data Element Name
User Commands	(non-data)	MAV Landed	Landing Fault, Airframe Fault, MAV Launch Fault, Ground Station Fault	Content
Flight Profile and Directives	Power for Payload	Physical Interaction resulting in successful recovery	Physical Interaction involving platform maintenance	Format Type
				Media Type
				Accuracy
				Units of Measurement
				Data Standard
MAV Airborne Communication System	Air Vehicle	Human Operator	Human Operator	Sending System Name
De-Modulate MAV Directives	Power Source	Influence System	Maintain System	Sending System Function Name
Air Vehicle	Payload or Sensor Package	Air Vehicle	Air Vehicle	Receiving System Name
Flight Control	Enable ISR Capability	Take Flight	N/A	Receiving System Function Name
Intermode Hardware Connection	Intermode Hardware Connection	Physical Interaction	Physical Interaction	Transaction Type
Updated Directives Available for Flight Control	Power Available to Payload	Recover Platform	Platform Maintenance	Triggering Event
Level 1 Connected (Peer-to-Peer)	Level 1 Connected (Peer-to-Peer)	Level 0 Isolated (Manual)	Level 0 Isolated (Manual)	Interoperability Level Achieved (C4ISR WG)
Mission Essential	Mission Essential	Mission Essential	Mission Essential	Criticality
Occurs frequently during mission	Whenever MAV system node is engaged	Recover varies by mission	Maintenance should only occur if required	Periodicity
In Seconds	Constant Power Delivered	Recover in minutes	Should only require minimal effort (in minutes)	Timeliness
				Throughput
				Size
				Access Control
				Availability
				Confidentiality
				Dissemination Control
				Integrity
				Non-Repudiation Producer
				Non-Repudiation Consumer
				Protection (Type, Name, Duration, Date)
				Classification
				Classification Caveat
				Releasability
				Security Standard

Figure N.5 SV-6 Systems Data Exchange Matrix 5

Row ID					
24	23	22	21	System Interface Name	Interface Identifier
Request / Commands, ISR Data	Request / Commands, ISR Data	Power, MAV Directives, and Status Interface	Power, MAV Directives, and Status Interface	System Data Exchange Name	Data Exchange Identifier
ISR Data	Flight Status Data	Platform Status	Airborne Communication Power	Data Element Name	Data Description
Raw Sensor Package Data	Raw Flight Telemetry Data	Raw Flight Telemetry Data	(non-data)	Content	
ISR Sensor Data	Air Platform Status	Current position, power levels, flight control measurements	Power for Airborne Comm system	Format Type	
				Media Type	
				Accuracy	
				Units of Measurement	
				Data Standard	Producer
MAV Airborne Communication System	MAV Airborne Communication System	Air Vehicle	Air Vehicle	Sending System Name	
Transmit Data	Transmit Data	Flight Control	Power Source	Sending System Function Name	
MAV Ground Communication System	MAV Ground Communication System	MAV Airborne Communication System	MAV Airborne Communication System	Receiving System Name	Consumer
Receive Data	Receive Data	Modulate Data	Accept Supplied Power	Receiving System Function Name	
Data Transmission	Data Transmission	Intermode Hardware Connection	Intermode Hardware Connection	Transaction Type	Nature of Transaction
Sensor receives information	Platform senses change in flight or system status	Updated Status Information Available	Power Available to Comm	Triggering Event	
Level 1 Connected (Peer-to-Peer)	Level 1 Connected (Peer-to-Peer)	Level 1 Connected (Peer-to-Peer)	Level 1 Connected (Peer-to-Peer)	Interoperability Level Achieved (C4ISR WG)	
Mission Essential	Needed to ensure Mission effectiveness	Somewhat Mission Essential	Mission Essential	Criticality	
Occurs whenever sensor is enabled (very often)	Occurs whenever platform status has changed	Occurs frequently during mission	Whenever MAV system node is engaged	Periodicity	Performance Attributes
Varies by Separation Distance, User Reaction, and Command Processing (in seconds)	Varies by Separation Distance, User Reaction, and Command Processing (in seconds)	In Seconds	Constant Power Delivered	Timeliness	
				Throughput	
				Size	Information Assurance
				Access Control	
				Availability	
				Confidentiality	
				Dissemination Control	
				Integrity	
				Non-Repudiation Producer	
				Non-Repudiation Consumer	Security
				Protection (Type, Name, Duration, Date)	
				Classification	
				Classification Caveat	
				Releasability	
				Security Standard	

Figure N.6 SV-6 Systems Data Exchange Matrix 6

			Row ID
27 User Feedback and Inputs	26 User Feedback and Inputs	25 Request / Commands, ISR Data	System Interface Name
			System Data Exchange Name
User Inputs	User Feedback	Request or Command Information	Data Exchange Identifier
Flight Plan	Decoded Sensor Package Data	User Commands	Data Element Name
Physical Data Entry	Audio, Video Feedback	Platform Directives, Mission Profiles, etc.	Content
			Format Type
			Media Type
			Accuracy
			Units of Measurement
			Data Standard
Human Operator	Human Computer Interface	MAV Ground Communication System	Sending System Name
Influence System	Give Feedback	Transmit MAV Directives	Sending System Function Name
Human Computer Interface	Human Operator	MAV Airborne Communication System	Receiving System Name
Accept Input	Process Info	Receive MAV Directives	Receiving System Function Name
Manual Physical Interaction	Optical or Acoustic Transmission	Data Transmission	Transaction Type
User wishes to input changes to system	Supplied Audio/Video Data	User wishes to create or modify flight profile	Triggering Event
Level 0 Isolated (Manual)	Level 0 Isolated (Manual)	Level 1 Connected (Peer-to-Peer)	Interoperability Level Achieved (C4ISR WG)
Mission Essential	Mission Essential	Mission Essential	Criticality
Varies by user and mission	Video/Audio is constantly being supplied	Varies by User	Periodicity
Input in seconds	Feedback in seconds	Varies by Separation Distance, User Reaction, and Command Processing (in seconds)	Timeliness
			Throughput
			Size
			Access Control
			Availability
			Confidentiality
			Dissemination Control
			Integrity
			Non-Repudiation Producer
			Non-Repudiation Consumer
			Protection (Type, Name, Duration, Date)
			Classification
			Classification Caveat
			Releasability
			Security Standard

Figure N.7 SV-6 Systems Data Exchange Matrix 7

Bibliography

1. “Information Technology Management Reform Act (ITMRA) and the Federal Acquisition Reform Act.” 40 U.S.C 1401(3), February 1996.
2. “Transmittal Memorandum #4: Management of Federal Information Resources.” Office of Management and Budget Circular A-130, November 2000.
3. *CJCSI 3170.01B, Requirements Generation System*. Technical Report. Government Printing Office, April 2001.
4. “IDEF Family of Methods, A Structured Approach to Enterprise Modeling and Analysis.” <http://www.idef.com/Home.htm>, March 2005.
5. “RQ-1 Predator.” http://www.globalaircraft.org/planes/rq-1_predator.pl, February 2005.
6. “RQ-4 Global Hawk.” http://www.globalaircraft.org/planes/rq-4_global_hawk.pl, February 2005.
7. “What is Systems Engineering.” <http://www.incose.org/practice/whatisystemseng.aspx>, January 2005.
8. Bienvenu, Michael P., et al. “C4ISR Architectures: III. An Object-Oriented Approach for Architecture Design,” *Systems Engineering*, 3(4):288–312 (December 2000).
9. C4ISR Working Group. *C4ISR Architecture Framework 2.0*. December 1997.
10. C4ISR Working Group. *Levels of Information Systems Interoperability (LISI)*. Technical Report. DoD, March 1998.
11. Defense Science Board. *Unmanned Aerial Vehicles and Uninhabited Combat Aerial Vehicles*. Technical Report. 2004.
12. Department of Defense. *UAV Roadmap 2002*. Technical Report. Under Secretary of Defense, November 2002.
13. Department of Defense. *DoD Instruction 5000.2, Operation of the Defense Acquisition System*. DoD Instruction 5000.2. April 2003.
14. Department of Defense. *CJCSM 3170.01A, Operation of the Joint Capabilities Integration and Development System (JCIDS)*. DoD Manual CJCSM 3170.01A. March 2004.
15. Department of Defense, Joint Chiefs of Staff, J6. *CJCSI 6212.01B, Interoperability and Supportability of National Security Systems and Information Technology Systems*. Technical Report. May 2000.

16. Fahlstrom, Paul G. and Thomas J. Gleason. *Introduction to UAV Systems* (2nd Edition). UAV Systems Inc, 1998.
17. Finn, Anthony and others, "Miniature UAV's & Future Electronic Warfare."
18. Frelinger, David R. and others, "Aerospace Operations in Urban Environments: Exploring New Concepts." RAND, 2000.
19. Garamone, Jim, "From the U.S. Civil War, to Afghanistan: A Short History of UAVs." <http://www.gordon.army.mil/AC/sumr02/uav2.htm>, September 2004.
20. Gerken, Louis. *UAV (Unmanned Aerial Vehicle)*. Number ISBN 096171347, American Scientific Corp., April 1991.
21. Goebel, Greg, "Miniature UAVs." <http://www.vectorsite.net/twuav17.html>, November 2004.
22. Gotel, O and A Finkelstein. "An Analysis of the Requirements Traceability Problem," *Proc. of First International Conference on Requirements Engineering*, 94–101 (1994).
23. Government Accounting Office. *Unmanned Aerial Vehicles DoD's Demonstration Approach Has Improved Project Outcomes*. Technical Report GAO/NSIAD-99-33. 1999.
24. *Department of Defense Architectural Framework Volume II*. Technical Report. Government Printing Office, August 2003.
25. Headquarters USSOCOM. *USSOCOM Posture Statement*. Technical Report. 2003.
26. Howard, Stephen P. *Special Operations Forces and Unmanned Aerial Vehicles: Sooner or Later?*. MS thesis, School of Advanced Airpower Studies, June 1995.
27. Huber, Arthur F. *Death by a Thousand Cuts: Micro-Air Vehicles in the Service of Air Force Missions*. MS thesis, Air War College, Maxwell AFB, AL, April 2001.
28. IEEE Software Engineering Standards Committee Architecture Working Group, "IEEE Recommended Practice for Architectural Description of Software-Intensive Systems," 2000.
29. Kossiakoff, Alexander and William N. Sweet. *Systems Engineering; Principles and Practice*. Wiley Interscience, 2003.
30. Kowalchuk, Ellen. "AFIT Stands Up Systems Engineering Center," *Air Education and Training Command News Service (AETCNS)* (February 2003).
31. Levis, Alexander H. and Lee W. Wagenhals. "C4ISR Architectures: I. Developing a Process for C4ISR Architecture Design," *Systems Engineering*, 3(4):225–247 (December 2000).
32. McMichael, James S. and Michael S. Francis, "Micro Air Vehicles: Toward a New Dimension in Flight," August 1997.

33. National Institute of Standards and Technology, "NIST Policy on Traceability." <http://ts.nist.gov/traceability/nist%20traceability%20policy-external.htm>, January 2005.
34. Object Management Group. *UML Primer 2000, What Is OMG-UML and Why Is It Important?*. Phamplet. 2000.
35. Office of Management and Budget. *Preparation, Submission and Execution of the Budget*. Technical Report. Washington: Government Printing Office, July 2004.
36. Parsch, Andreas, "Directory of U.S. Military Rockets and Missiles Appendix 4: Undesignated Vehicles QH-50." <http://www.designation-systems.net/dusrm/app4/qh-50.html>, November 2004.
37. Sage, Andrew P. *Systems Engineering*. Wiley Interscience, 1992.
38. Schramm, Fred, "Need for Traceability." http://www.aiag.org/education/autoid_presentations/2004/keynote.pdf, November 2004.
39. Tluchowski, Michael A. *The UAV and the Operational Commander*. MS thesis, Naval War College, February 2002.
40. United States Air Force. *Air Force Task List (AFTL)*. USAF Document AFDD 1-1. August 1998.
41. United States Army. *FM 34-25-2, Unmanned Aerial Vehicle (UAV) (Test Draft, June 95)*. Technical Report. United States Army, June 1995.
42. Wagenhals, Lee W., et al. "C4ISR Architectures: II. A Structured Analysis Approach for Architecture Design," *Systems Engineering*, 3(4):248 – 287 (2005).
43. Warner, Gary A. *Unmanned Aerial Vehicles: Where Are They Going and Where do They Belong*. MS thesis, CSC, 1995.
44. Weed, Shawn C. *The Quality of Quantity: Mini-UAVs as an Alternative UAV Acquisition Strategy at the Army Brigade Level*. MS thesis, School of Advanced Studies United States Army Command and General Staff College, 2002.

REPORT DOCUMENTATION PAGE

*Form Approved
OMB No. 074-0188*

The public reporting burden for this collection of information is estimated to average 1 hour per response, including the time for reviewing instructions, searching existing data sources, gathering and maintaining the data needed, and completing and reviewing the collection of information. Send comments regarding this burden estimate or any other aspect of the collection of information, including suggestions for reducing this burden to Department of Defense, Washington Headquarters Services, Directorate for Information Operations and Reports (0704-0188), 1215 Jefferson Davis Highway, Suite 1204, Arlington, VA 22202-4302. Respondents should be aware that notwithstanding any other provision of law, no person shall be subject to a penalty for failing to comply with a collection of information if it does not display a currently valid OMB control number.

PLEASE DO NOT RETURN YOUR FORM TO THE ABOVE ADDRESS.

1. REPORT DATE (DD-MM-YYYY) 21 Mar 05		2. REPORT TYPE Master's Thesis		3. DATES COVERED (From - To) Jul 04 - Mar 05	
4. TITLE AND SUBTITLE A Systems Architectural Model for Man-Packable/Operable Intelligence, Surveillance, and Reconnaissance Mini/Micro Aerial Vehicles				5a. CONTRACT NUMBER	
				5b. GRANT NUMBER	
				5c. PROGRAM ELEMENT NUMBER	
6. AUTHOR(S) Cooper, Cory A., Captain, USAF Ewoldt, Matthew L., Captain, USAF Meyer, Steaven A., Captain, USAF Talley, Edward W., Second Lieutenant, USAF				5d. PROJECT NUMBER JON# 05-206	
				5e. TASK NUMBER	
				5f. WORK UNIT NUMBER	
7. PERFORMING ORGANIZATION NAMES(S) AND ADDRESS(S) Air Force Institute of Technology Graduate School of Engineering and Management (AFIT/EN) 2950 Hobson Way WPAFB OH 45433-7765				8. PERFORMING ORGANIZATION REPORT NUMBER AFIT/GSE/ENY/05-M02	
9. SPONSORING/MONITORING AGENCY NAME(S) AND ADDRESS(ES) AFRL/MNAV Attn: Captain Ian Bautista 101 West Eglin Blvd, Suite 329 Eglin AFB FL 32452 DSN: 872-9443 x2344				10. SPONSOR/MONITOR'S ACRONYM(S)	
				11. SPONSOR/MONITOR'S REPORT NUMBER(S)	
12. DISTRIBUTION/AVAILABILITY STATEMENT APPROVED FOR PUBLIC RELEASE; DISTRIBUTION UNLIMITED.					
13. SUPPLEMENTARY NOTES					
14. ABSTRACT With the increase in both technology push and operational pull of mini/micro aerial vehicles (MAVs) within DoD organizations, an understanding of their interactions and capabilities is necessary. Many MAVs have already been developed for a specific usage and much speculation has been made on their future uses. Despite the growth of MAVs, there is currently no overarching systems architecture which would envelop and guide the DoD's MAV development efforts. The goal of this thesis is to apply sound systems engineering principals to develop a MAV architectural model describing their use in three separate but closely related mission areas: Over-the-Hill-Reconnaissance, Battle Damage Information, and Local Area Defense. This thesis focuses on single-man packable/operable MAVs utilized by small ground units synonymous with special operations forces. The three mission areas are combined to define a single overarching Intelligence, Surveillance, and Reconnaissance (ISR) MAV architecture. This architecture focuses on the current state of ISR MAVs and provides a baseline current capability. From this architecture, areas of interest relating to MAVs and their use in the DoD are discussed, focusing on enhancing both current and future capabilities of MAVs.					
15. SUBJECT TERMS Mini Aerial Vehicle, Micro Aerial Vehicle, MAV, Un-Manned Aerial Vehicle, UAV, Over-the-Hill Reconnaissance, Battle Damage Information, BDI, Local Area Defense, LAD, Intelligence, Surveillance, and Reconnaissance, ISR, DoD Architecture Framework, DoDAF, Integrated Architectures, Systems Engineering					
16. SECURITY CLASSIFICATION OF:		17. LIMITATION OF ABSTRACT		18. NUMBER OF PAGES	
REPORT	ABSTRACT	UU		244	
U	U				
c. THIS PAGE		19a. NAME OF RESPONSIBLE PERSON			
U		Walter, Joerg, Major, USAF			
19b. TELEPHONE NUMBER (Include area code) (937) 255-3355, ext 3550; e-mail: joerg.walter@afit.edu					